

## **Notes 2. Appendix**

# **One-Dimensional Fluid Film Bearings**

**Analysis for load capacity and drag in**

**A. Plane Slider Bearing**

**B. Rayleigh Step Bearing**

**C. Elementary Squeeze Film Flow**

**Objective: To understand the static load performance of simple 1D bearings. Actual configurations in practice follow similar design guidelines to ensure optimum performance.**

**Modern Lubrication. Luis San Andrés © 2009**

# Analysis of 1D slider bearing:

Luis San Andres (c) 2009 (NUS)

Figure 1 shows the geometry and coordinate system of a one-dimensional slider (thrust) bearing. The film thickness ( $h$ ) has a linear taper along the direction of the surface velocity  $U$ . The film wedge generates a hydrodynamic pressure field that supports an applied load  $w$ .

Note that the (exit) minimum film thickness  $h_2$  is unknown and must be determined as part of the bearing design. The bearing taper ( $h_1-h_2$ ) is a design parameter (determined from analysis).

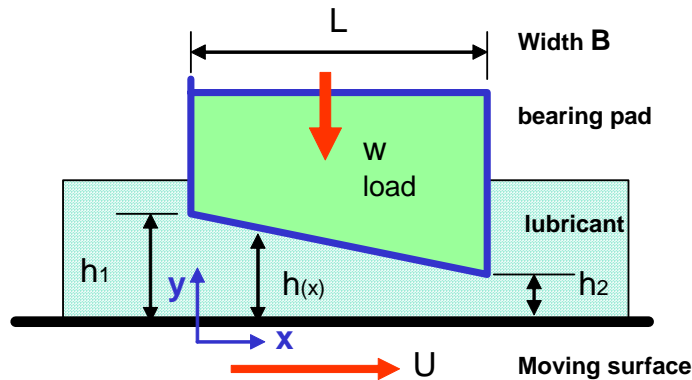

film thickness,  $h(x)$

$h_1$  at inlet (leading edge)

$h_2$  at exit (trailing edge)

Fig. 1 Geometry of taper slider bearing

## Nomenclature:

- $U$  surface speed
- $L$  bearing length
- $B$  bearing width,  $B \gg L$
- $\mu$  lubricant viscosity
- $w$  Load

## Assumptions:

- incompressible lubricant, isoviscous,
- steady state operation,  $dh/dt=0$
- width  $B \gg L$
- no fluid inertia effects

$$h(x) = h_1 + (h_2 - h_1) \cdot \frac{x}{L} \quad (1)$$

$$h_1 > h_2$$

**Reynolds eqn.** for generation of hydrodynamic pressure (p) reduces to:

$$\frac{d}{dx} \left( \frac{h^3}{12 \cdot \mu} \cdot \frac{d}{dx} p - \frac{U \cdot h}{2} \right) = 0 \quad \text{with } p=0 \text{ (ambient) at } x=0 \text{ and } L \text{ (inlet and exit of bearing)} \quad (2)$$

Define the following dimensionless variables

$$X = \frac{x}{L} \quad P = \frac{p}{\frac{6 \cdot \mu \cdot U \cdot L}{h_2^2}} \quad H = \frac{h}{h_2} \quad H(X, \alpha) := \alpha + (1 - \alpha) \cdot X \quad (3)$$

where  $\alpha = \frac{h_1}{h_2}$  is a **film thickness ratio or taper ratio**

hence, Eq. (2) becomes

$$\frac{d}{dX} \left( H^3 \cdot \frac{d}{dX} P - H \right) = 0$$

A first integral of this equation renders a constant, proportional to the flow rate  $Q_x$ , i.e.

$$\left( H^3 \cdot \frac{d}{dX} P - H \right) = -Q_X \quad (4)$$

Integration of Eq. (4) is rather simple for the film **tapered** profile. After some algebraic manipulation and application of the pressure boundary conditions at the inlet and exit planes of the bearing, the end result is

$$P(X, \alpha) := \frac{\alpha}{1 - \alpha^2} \cdot \left( \frac{1}{H(X, \alpha)^2} - \frac{1}{\alpha^2} \right) - \frac{1}{1 - \alpha} \cdot \left( \frac{1}{H(X, \alpha)} - \frac{1}{\alpha} \right) \quad (5)$$

Figure 2 depicts the pressure profile for four film taper ratios,  $\alpha=1.5, 2, 3$  and  $4$ . Note that as  $\alpha$  increases the peak pressure increases. However, for  $\alpha>2.2$  the peak pressure levels off.

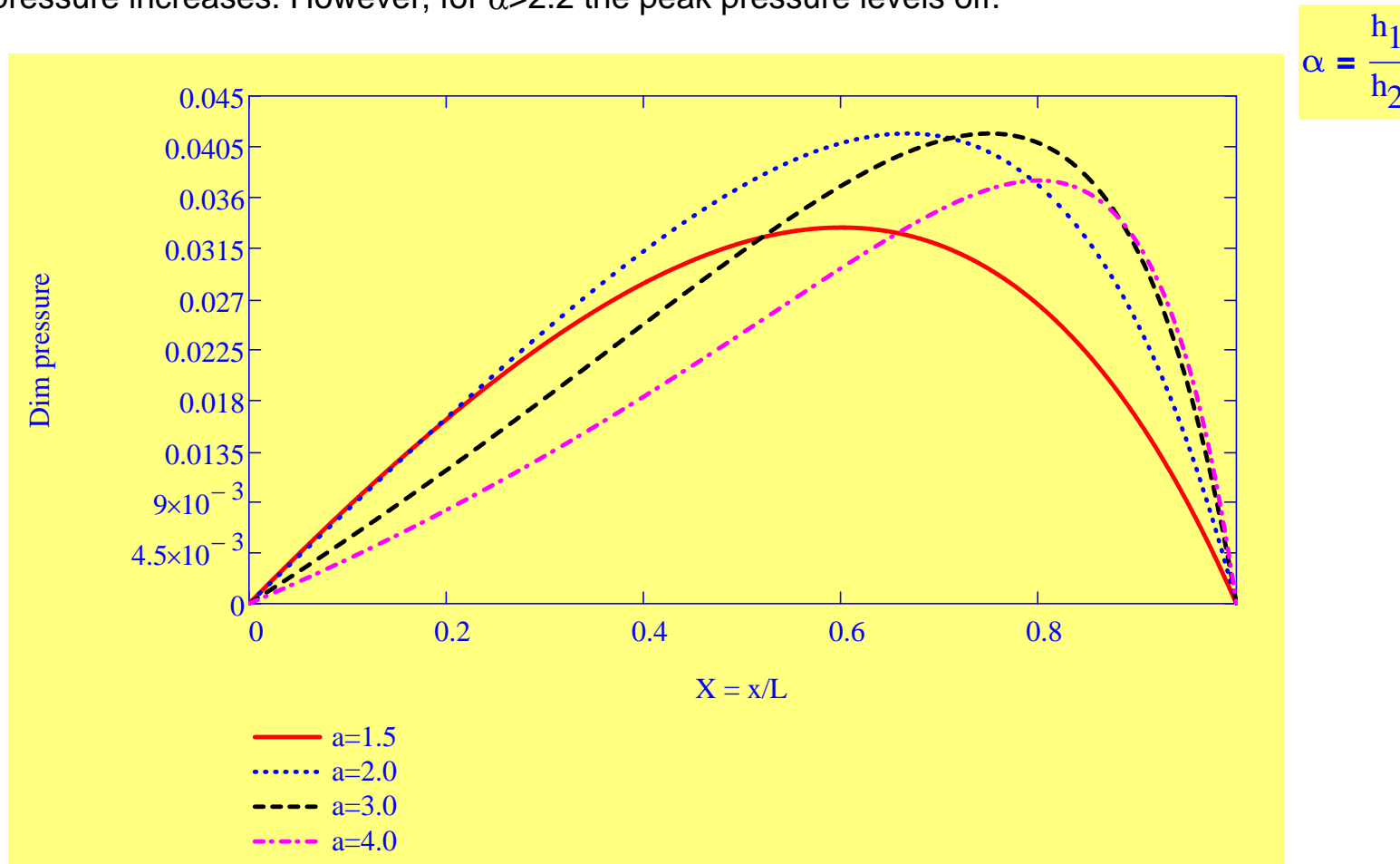

**Fig 2. Dimensionless pressure for 1D-slider bearing and increasing film thickness (inlet/exit) ratios  $\alpha$**

The analysis determines

$$P_{\max}(\alpha) := \frac{(\alpha - 1)}{4 \cdot \alpha \cdot (1 + \alpha)}$$

at location

$$x_{P_{\max}}(\alpha) := \frac{\alpha}{\alpha + 1}$$

and volumetric flow rate

$$q_x(\alpha) = \left( h_2 \cdot \frac{U}{2} \cdot B \right) \cdot Q_x \quad (7)$$

where

$$Q_x(\alpha) := \frac{2 \cdot \alpha}{1 + \alpha}$$

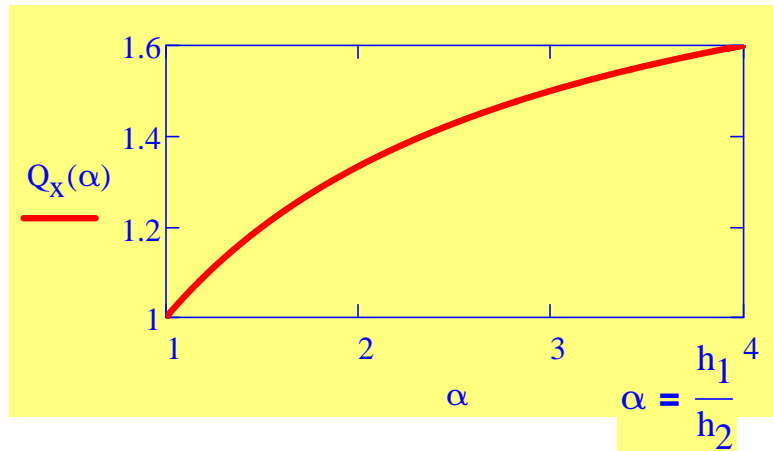

(6)

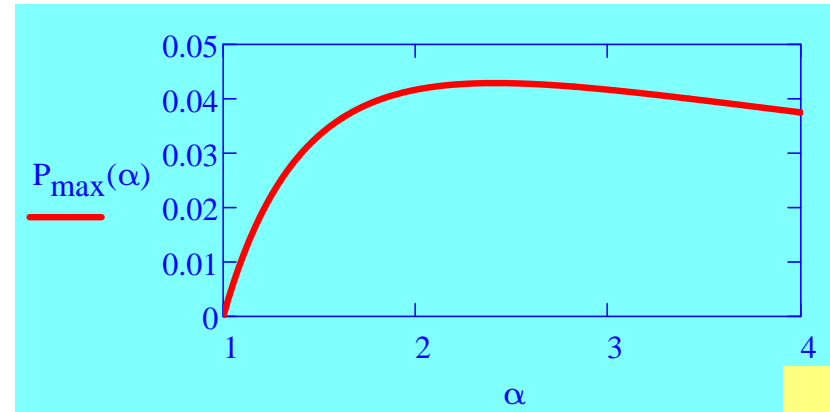

$$\alpha_{P_{\max}} := 1 + \sqrt{2}$$

$$P_{\max}(\alpha_{P_{\max}}) = 0.043$$

$$\alpha_{P_{\max}} = 2.414$$

Integration of the pressure field over the pad surface renders the bearing reaction force opposing the applied

load w, i.e

$$w = \int_0^L P(x) dx \cdot B = \frac{6 \cdot \mu \cdot U \cdot L^2 \cdot B}{h_2^2} \cdot W(\alpha) \quad W = \int_0^1 P(X) dX \quad (8a)$$

Substitution of the pressure field above gives, after considerable algebraic manipulation:

$$W(\alpha) := \frac{1}{(1-\alpha)^2} \left[ \ln(\alpha) + 2 \cdot \frac{(1-\alpha)}{1+\alpha} \right] \quad (8b)$$

There is an optimum film ratio  $\alpha$  that determines the **largest load capacity**. This optimum ratio is determined from

$$\frac{d}{d\alpha} W(\alpha) = 0$$

$$\alpha_{\text{opt}} := 2.1889$$

$$W(\alpha_{\text{opt}}) = 0.0267$$

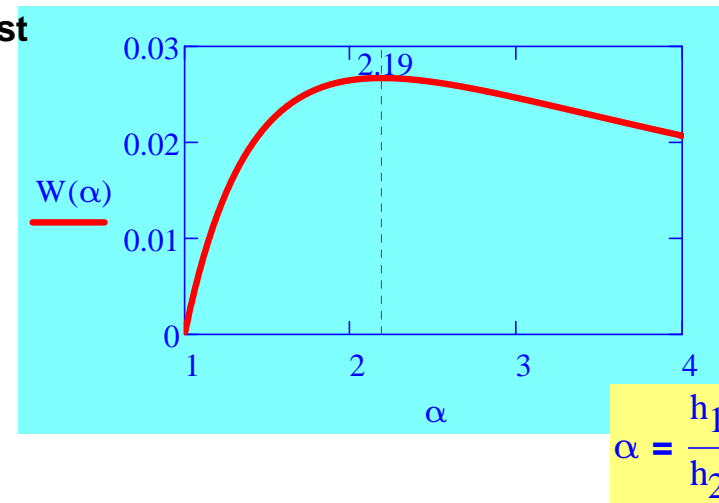

Note that too large taper ratios,  $\alpha > \alpha_{\text{opt}}$  act to reduce the load capacity. The formula above shows that the machined taper  $(h_1-h_2) \sim 2.18 h_1$  for maximum load carrying.

It is also important to determine the **shear force** due to the fluid being dragged into the thin film region. This

force equals

$$f = \int_0^L \tau_w(x) dx \cdot B$$

(9a)

where  $\tau_w$  is the shear stress at the moving wall

$$\tau_w(x) = \mu \cdot \left( \frac{d}{dy} V_x \right) \quad \text{at } y=0 \quad (10a)$$

The fluid velocity field  $V_x$  adds the Poiseuille and Couette contributions, i.e. due to pressure and shear, respectively; i.e.

$$V_x = \frac{1}{2 \cdot \mu} \cdot \left( \frac{d}{dx} p \right) \cdot (y^2 - h \cdot y) + U \cdot \left( 1 - \frac{y}{h} \right)$$

Then

$$\tau_w = \mu \cdot \frac{dV_x}{dy} = \frac{-h}{2} \cdot \frac{d}{dx} p - \mu \cdot \frac{U}{h} \quad \text{at } y=h \text{ (moving wall)}$$

Substitution of the pressure profile above and integration over the pad surface gives a shear force

$$f = \frac{\mu \cdot U \cdot L \cdot B}{h_2} \cdot F(\alpha) \quad F(\alpha) := -\left(\frac{6}{1+\alpha} + \frac{4 \cdot \ln(\alpha)}{1-\alpha}\right) \quad (10b)$$

The **power lost** dragging the fluid is

$$P_w = f \cdot U \quad (11)$$

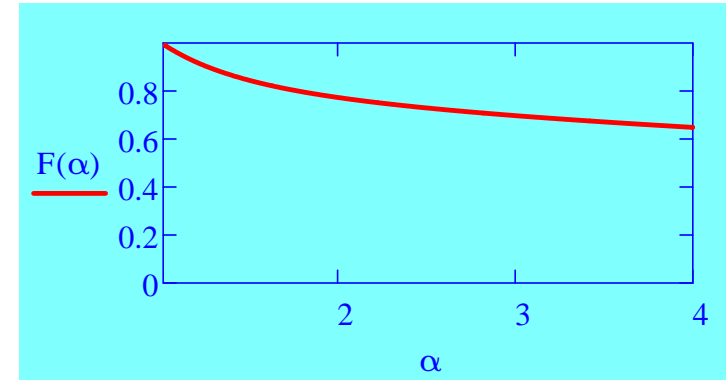

It is customary to define a **coefficient of friction**  $\mu_f$  relating the shear force to the applied load, i.e

$$\mu_f = \frac{f}{w} = \frac{h_2}{L} \cdot \mu \mu(\alpha) \quad \mu \mu(\alpha) := \frac{F(\alpha)}{W(\alpha) \cdot 6}$$



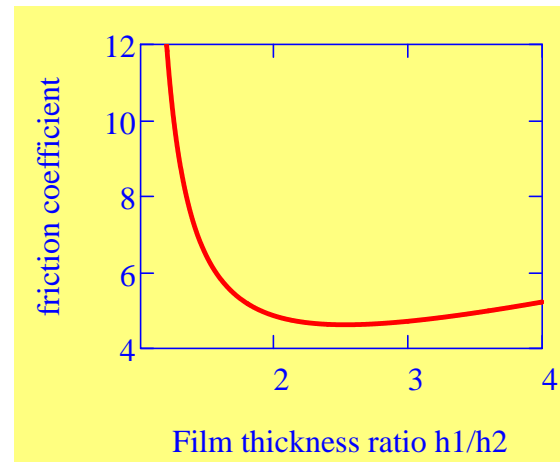

Since  $h_2/L \ll 1$ , the friction coefficient  $\mu_f$  is actually much smaller than the dimensionless coefficient  $\mu$  displayed in the graph above.

Figure 3 below depicts the dimensionless peak pressure, load capacity, shear force and flow rate for the 1D-slider bearing as a function of the film thicknesses ratio  $\alpha$

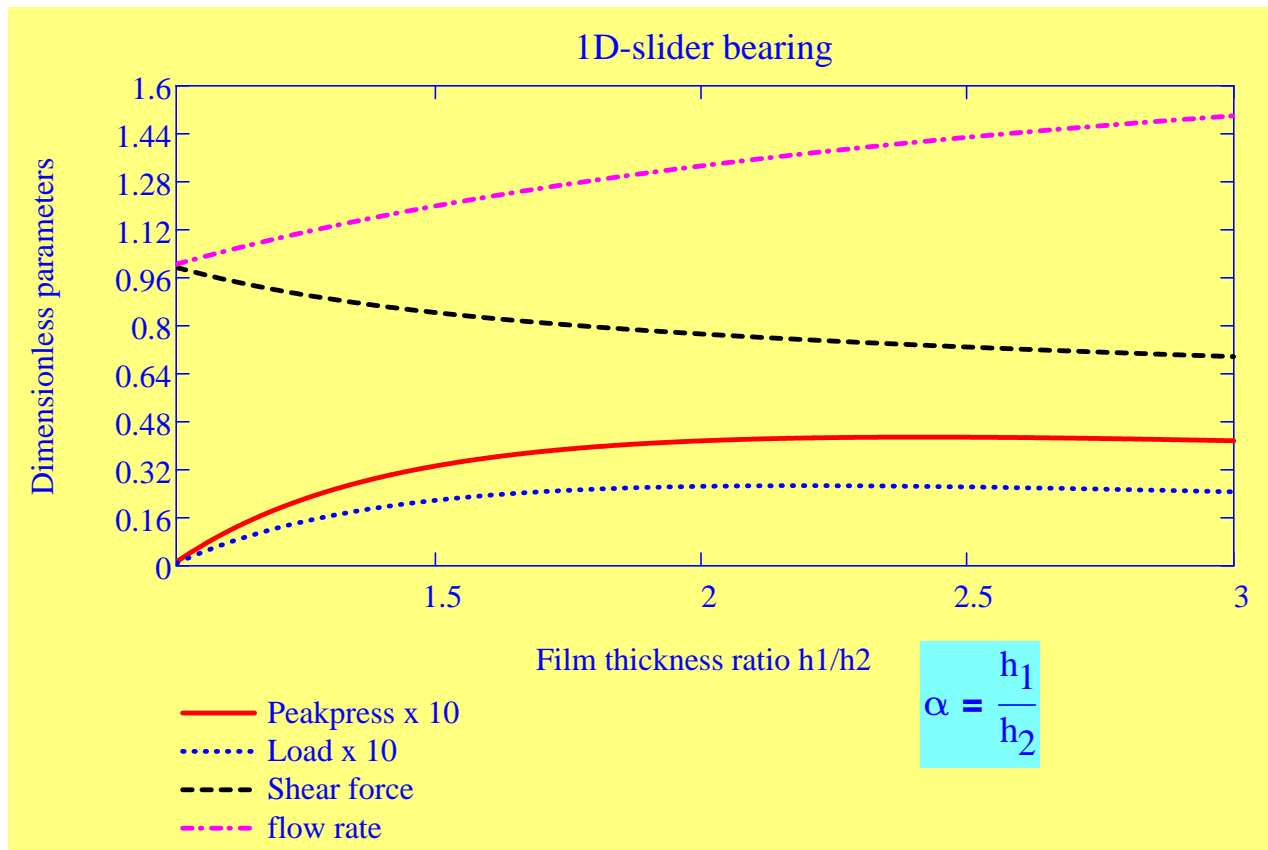

Fig 3. Performance parameters for tapered 1D-slider bearing. Increasing film ratios  $\alpha$

## Thermal effects

Thus far the analysis considers the lubricant viscosity to remain invariant. However, most lubricants (mineral oils) have a viscosity strongly dependent on its temperature. In actuality, as the lubricant flows through the film thickness it becomes hotter because it must carry away the mechanical power dissipated within the film.

Analysis of fluid film bearings with thermal effects is complicated since the film temperature changes even across the film thickness. Such analysis is presently out of scope, i.e. within the framework of the notes hereby presented.

Nonetheless, a simple method follows to estimate in a global form -as in a **lumped system**- the overall temperature raise of the lubricant and its effective lubricant viscosity to use in the analysis and design of a bearing.

The mechanical power is not only carried away by the lubricant flow but also conducted to and through the bearing bounding solid surfaces - bearing and moving collar.

Recall that the mechanical power dissipated equals  $P_w = f U$  and converted into heat that is carried away by the lubricant. A balance of mechanical power and heat flow gives

$$\kappa \cdot P_w = \rho \cdot C_p \cdot q_x \cdot \Delta T \quad \Delta T = T_{\text{exit}} - T_{\text{inlet}} \quad (12)$$

where  $\rho$  and  $C_p$  are the lubricant density and heat capacity, respectively;  $q_x$  is the flow rate, and  $\Delta T$  is the temperature raise. Above  $\kappa$  is an (empirical) coefficient denoting the fraction of mechanical power converted into heat. Typically  $\kappa=0.8$ .

Substitution of the shear force ( $f$ ) and flow rate ( $q_x$ ) into the equation above gives

$$\Delta T = \kappa \cdot \left( \frac{\mu \cdot U \cdot L}{\rho \cdot C_p \cdot h^2} \right) \cdot \delta T(\alpha) \quad \delta T(\alpha) := \frac{F(\alpha)}{Q_x(\alpha)} \quad (13)$$

In the expression above, the viscosity is evaluated at an effective temperature,  $T_{eff}$ , which is taken as a weighted average between the inlet or supply temperature and the calculated exit temperature. Typically,

$$T_{eff} = T_{inlet} + \frac{\Delta T}{2} \quad (14)$$

In general, for applications not generating very high hydrodynamic pressures (GPa), the lubricant viscosity is an exponential decaying function of temperature.

$$\mu_{lub}(T) = \mu_{ref} \cdot e^{-\alpha_v \cdot (T - T_{ref})} \quad (15)$$

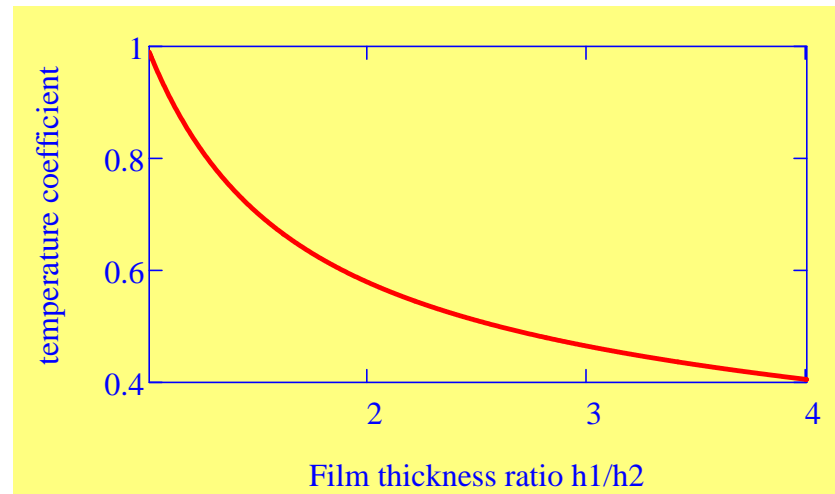

where  $T_{ref}$  and  $\mu_{ref}$  are reference lubricant temperature and viscosity, respectively.  $\alpha_v$  is a viscosity temperature coefficient

Lubricant technical specification charts provide the lubricant viscosity at two temperatures, 40C and 100C. Thus, the viscosity-temperature coefficient follows from, for example:

$$T_1 := 40 \quad T_2 := 100$$

$$\mu_1 := 32 \quad \mu_2 := 6$$

$$\alpha_v := \frac{\ln\left(\frac{\mu_1}{\mu_2}\right)}{(T_2 - T_1)}$$

$$\mu_{\text{lub}}(T) := \mu_1 \cdot e^{-\alpha_v \cdot (T - T_1)}$$

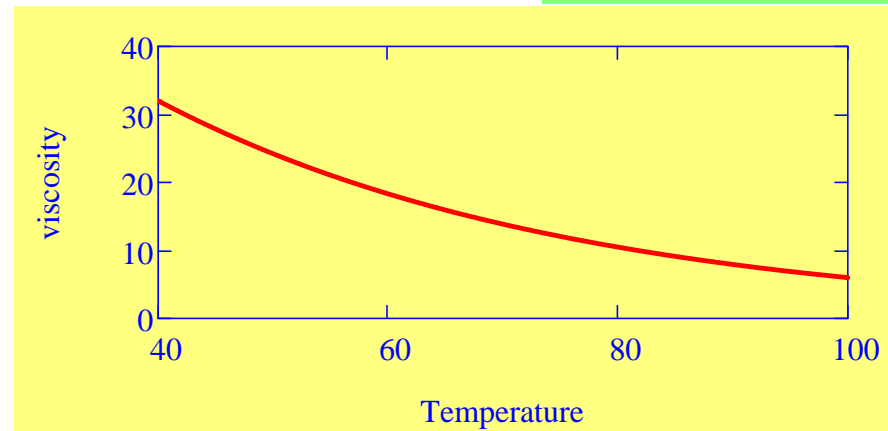

The bearing engineering design procedure follows an iterative procedure. Given the taper for the bearing ( $h_2-h_1$ ), surface velocity  $U$  and applied load  $w$ :

- a.** assume exit film thickness  $h_2$  and effective temperature, set effective viscosity and
  - b.** calculate bearing reaction load, flow rate, shear force and temperature raise
    - if bearing load > applied load, film thickness  $h_2$  is too small, increase  $h_2$
    - if bearing load < applied load, film thickness  $h_2$  is too large, reduce  $h_2$
  - c.** once **b.** is satisfied, check the effective temperature, if same as prior calculated then process has converged. Otherwise, reset effective temperature, calculate new viscosity and return to **b**
- A MATHCAD worksheet is provided for you to perform the analysis.

# Analysis of 1D Rayleigh step bearing:

Luis San Andres (c) 2009

Figure 1 shows the geometry and coordinate system of a one-dimensional Rayleigh step bearing. The film thickness  $h$  is a constant over each flow region, namely the ridge or step and the film land. The bottom surface moves with velocity  $U$ . The sudden change in film thickness generates a hydrodynamic pressure field that supports an applied load  $w$ .

Note that the minimum film thickness  $h_2$  is unknown and must be determined as part of the bearing design. The bearing step height ( $h_1 - h_2$ ) is a design parameter determined from the analysis.

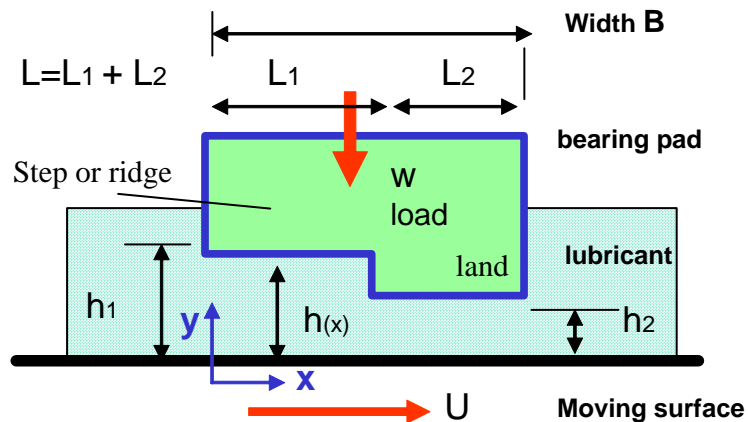

Fig. 1 Geometry of Rayleigh step bearing

$h(x)$  film thickness,

$h_1$  at inlet (leading edge)

$h_2$  at exit (trailing edge)

Two coordinate systems  $x_1$  and  $x_2$  aid to formulate the analysis

$$\begin{aligned}
 0 \leq x_1 \leq L_1 & \quad h(x_1) = h_1 & \quad h_1 > h_2 \\
 0 \leq x_2 \leq L_1 & \quad h(x_2) = h_2 & \quad (1)
 \end{aligned}$$

## Nomenclature:

$U$  surface speed       $w$  Load  
 $L$  bearing length  
 $B$  bearing width,  $B \gg L$   
 $\mu$  lubricant viscosity

## Assumptions:

- incompressible lubricant, isoviscous,
- steady state operation,  $dh/dt=0$
- **width  $B \gg L$**
- no fluid inertia effects
- rigid surfaces

Over each region, Reynolds eqn. for generation of hydrodynamic pressure (p) reduces to:

$$\frac{d}{dx} \left( \frac{h^3}{12 \cdot \mu} \cdot \frac{d}{dx} p - \frac{U \cdot h}{2} \right) = 0 \quad (2)$$

Integration of Reynolds Eqn over each flow region (step and land) is straightforward since the film thickness is constant

$$\frac{h_1^3}{12 \cdot \mu} \cdot \frac{d}{dx_1} p_1 - \frac{U \cdot h_1}{2} = -q_x \quad \frac{h_2^3}{12 \cdot \mu} \cdot \frac{d}{dx_2} p_2 - \frac{U \cdot h_2}{2} = -q_x \quad (3)$$

where  $q_x$  is the volumetric flow rate per unit width B. This flow rate is constant and equal in the two zones. Note that Eq. (3) shows the pressure gradient to be constant over each region, step and land; thus, the pressure varies linearly within each region, as shown in Figure 2.

for the step region, the boundary conditions are

$$\begin{aligned} \text{at } x_1 := 0 & \quad p_1(0) = 0 \\ \text{at } x_1 = L_1 & \quad p_1(0) = p_{\text{step}} \end{aligned} \quad (4a)$$

while for the land region, the boundary conditions are

$$\begin{aligned} \text{at } x_2 := 0 & \quad p_2(0) = p_{\text{step}} \\ \text{at } x_2 = L_2 & \quad p_2(0) = 0 \end{aligned} \quad (4b)$$

where  $p_{\text{step}}$  is the pressure at the step-land interface. Note that this pressure is also the highest within the film flow region. The step pressure is determined by equating the flow rates in Eqs. (3)

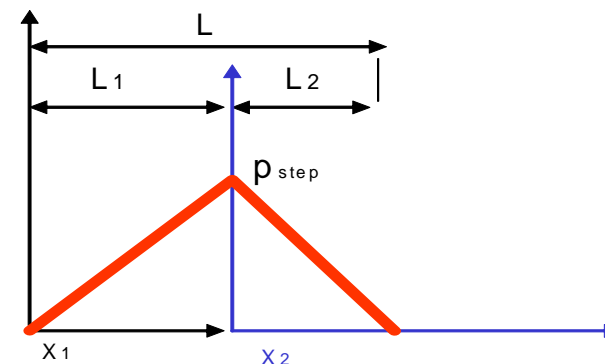

**Fig. 2 pressure profile for Rayleigh step bearing**

Define the following dimensionless parameters

$$\alpha = \frac{h_1}{h_2}$$

film thickness step to land ratio

$$\beta = \frac{L_2}{L_1}$$

step to land length ratio (5)

The analysis determines the step pressure to equal

$$P_{\text{step}} = \frac{6 \cdot \mu \cdot U \cdot L_2}{h_2^2} \cdot P_{\text{step}}(\alpha, \beta)$$

$$P_{\text{step}}(\alpha, \beta) := \frac{\alpha - 1}{1 + \alpha^3 \cdot \beta}$$

(6)

Note the peak pressure is largest at  $\alpha \sim 2$

and flow rate,

$$q_x = \frac{U}{2} \cdot h_2 \cdot Q_X(\alpha, \beta)$$

$$Q_X(\alpha, \beta) := \alpha \cdot \frac{(\alpha^2 \cdot \beta + 1)}{1 + \alpha^3 \cdot \beta}$$

(7)

$$\beta := 0.25$$

$$\beta = \frac{L_2}{L_1}$$

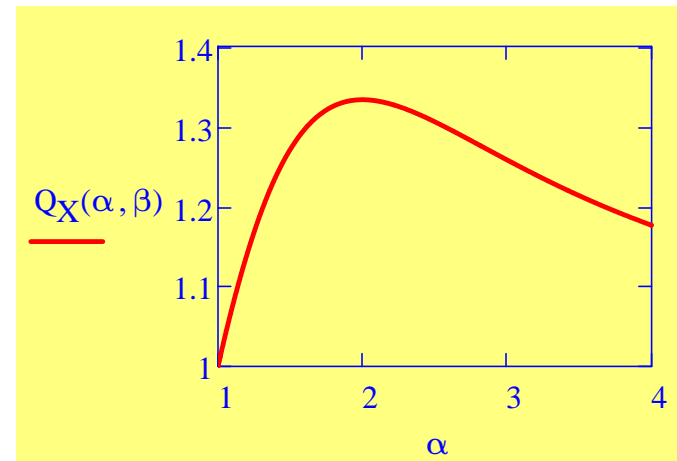
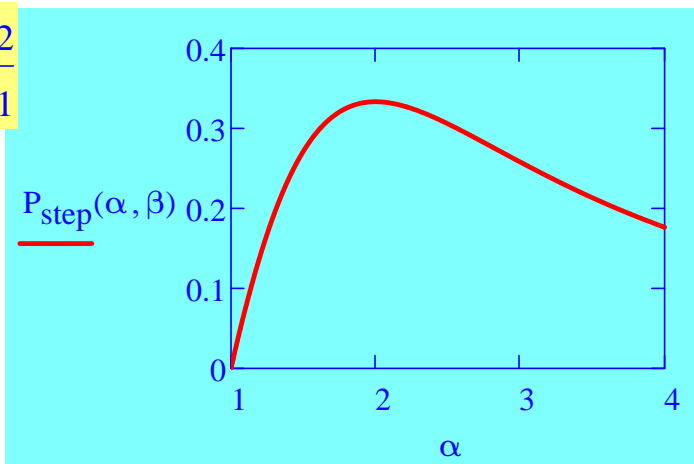

Since the pressure is linear over each region, integration of the pressure field over the bearing surface is straightforward and renders the bearing reaction force opposing the applied load  $w$ , i.e



$$w = \int_0^L P(x) dx \cdot B = \frac{L \cdot B}{2} \cdot p_{\text{step}}$$

$$W = \int_0^1 P(X) dX \quad (8a)$$



It is more meaningful to define the load in terms of the following **land to total length** ratio:

Hence,  $\beta(\gamma) := \frac{\gamma}{1-\gamma}$  and

$$\gamma = \frac{L_2}{L}$$

$$W = 6 \cdot \frac{\mu \cdot U \cdot B}{h_2^2} \cdot L^2 \cdot W(\gamma, \alpha)$$

$$W(\gamma, \alpha) := \frac{\gamma}{2} \cdot \frac{(\alpha - 1)}{1 + \alpha^3 \cdot \frac{\gamma}{1-\gamma}}$$

Figure 3 depicts the dimensionless load factor versus step to land ratio for four land to bearing length ratios  $\gamma$ . Clearly the maximum load occurs over a narrow range of film thickness ratios (1.5 to 2.25) and for land lengths around 30% of the total bearing length, i.e. steps extending to 70% of the bearing length.

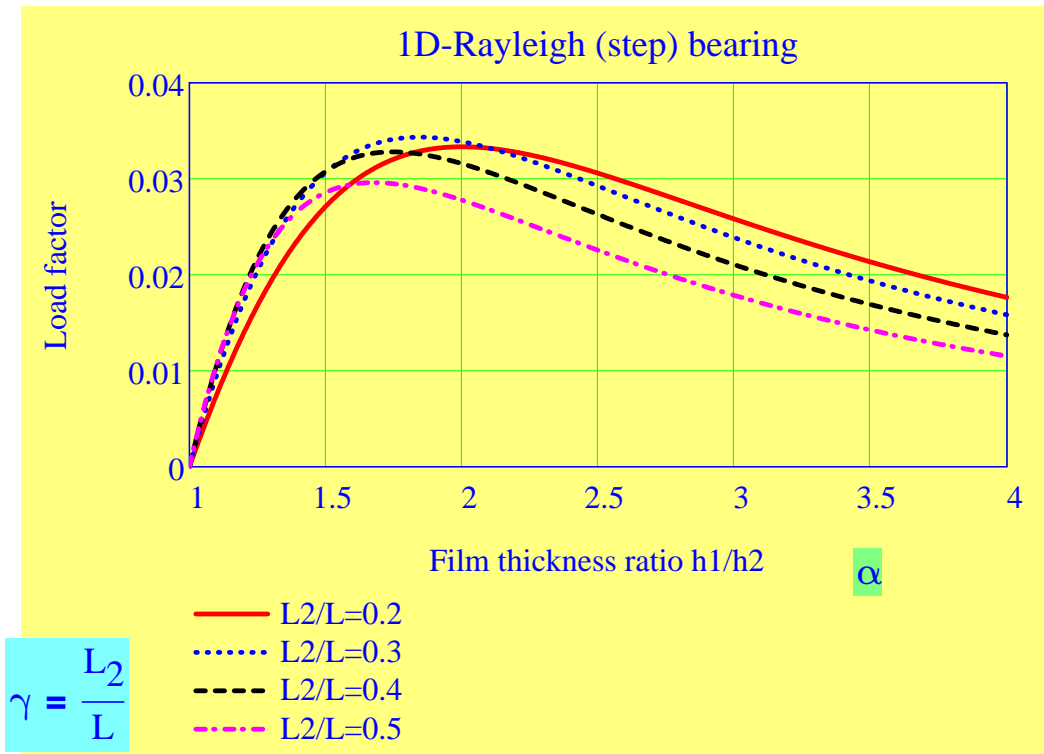

**Fig. 3 Load factor for Rayleigh step bearing for three land lengths**

Using MATHCAD one can determine easily the optimum film thickness ratio for a range of land lengths

Let: 
$$W(\gamma, \alpha) := \frac{\gamma}{2} \cdot \frac{(\alpha - 1)}{1 + \alpha^3 \cdot \frac{\gamma}{1 - \gamma}}$$

Define 
$$g = \frac{d}{d\alpha} W$$

$$\frac{d}{d\alpha} \left[ \gamma \cdot \frac{(\alpha - 1)}{1 + \alpha^3 \cdot \frac{\gamma}{1 - \gamma}} \right]$$

$$g(\alpha, \gamma) := \frac{\gamma}{\left[1 + \alpha^3 \cdot \frac{\gamma}{(1-\gamma)}\right]} - 3 \cdot \gamma^2 \cdot \frac{(\alpha-1)}{\left[1 + \alpha^3 \cdot \frac{\gamma}{(1-\gamma)}\right]^2} \cdot \frac{\alpha^2}{(1-\gamma)}$$



Set  $\gamma$ :

$$\frac{L2}{L}$$

$$\gamma := .30$$

change as needed

guess  $\alpha$ :

$$\alpha_g := 1.7 < 3$$

Solve for  $g = 0$

$$\alpha_{opt} := \text{root}(g(\alpha_g, \gamma), \alpha_g, 1.2, 3)$$

$$\alpha_{opt} = 1.843$$

$$W(\gamma, \alpha_{opt}) = 0.0343$$

**Compare with slider-bearing:**

$$\alpha_{opt} := 2.1889$$

$$W(\alpha_{opt}) = 0.0267$$

## Examples

$$\alpha_1 := 1.8 \quad \alpha_2 := \alpha_1 + .2 \quad \alpha_3 := \alpha_2 + .2 \quad \alpha_4 := \alpha_3 + .2$$

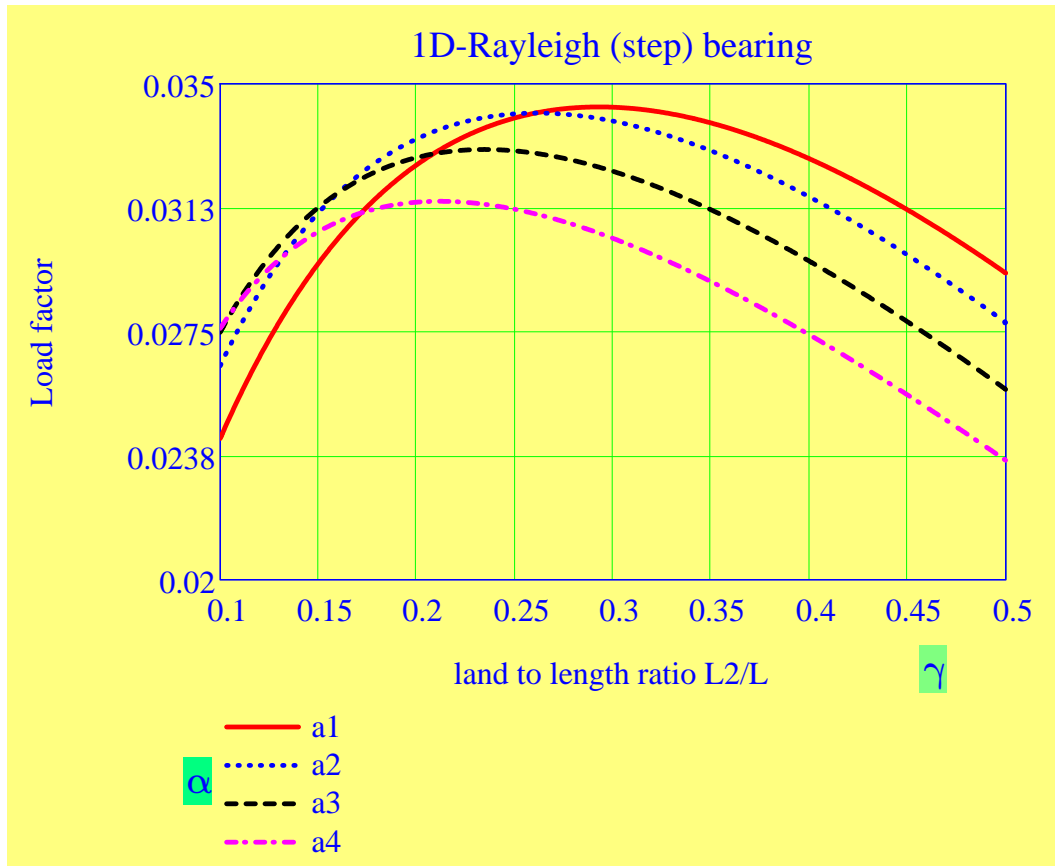

The maximum load occurs  
for land to length ratios  
 $0.22 < \gamma < 0.30$

$$\alpha_1 = 1.8$$

$$\alpha_2 = 2$$

$$\alpha_3 = 2.2$$

$$\alpha_4 = 2.4$$

# Analysis of simple squeeze film flow

Luis San Andres (c) 2009

Figure 1 shows the simplest squeeze film flow. Consider two circular (rigid) plates **fully immersed in a lubricant pool**. The plates are perfectly smooth and aligned with each other at all times. The film thickness separating the plates is a function of time only.

The top circular plate (of radius  $R$ ) moves towards or away from the bottom plate with velocity  $V = dh/dt$  (rate of change of film thickness). None of the plates rotates. There is no mechanical deformation of the plates

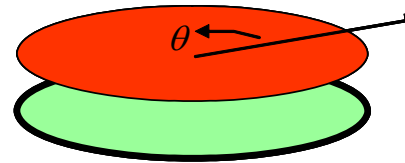
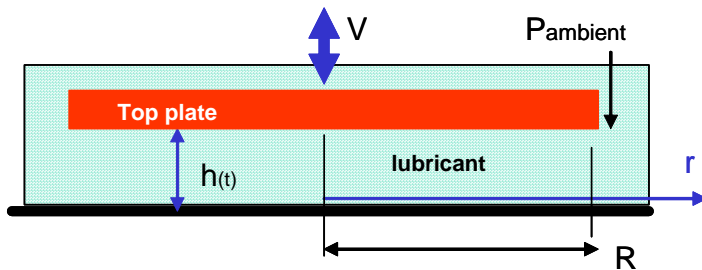

## Assumptions:

- incompressible lubricant, isoviscous,
- unsteady operation,  $dh/dt \neq 0$
- no fluid inertia effects
- no air entrainment
- rigid plates
- plates are fully submerged in a lubricant bath (to avoid air entrainment)

**Fig. 1 Geometry of two circular plates for squeeze film flow. Plates submerged in a lubricant pool.**

## Nomenclature:

$h(t)$  film thickness, only a function of time

$V = \frac{d}{dt}h$  top surface speed

$R$  plate outer radius

$\mu$  lubricant viscosity

$F$  squeeze film force

The film thickness is NOT a function of the radial (r) or angular ( $\theta$ ) coordinates. (**Axisymmetric flow**). Hence, Reynolds equation in polar coordinate reduces to

$$\frac{1}{r} \cdot \frac{d}{dr} (r \cdot q_r) + \frac{d}{dt} h = 0 \quad \text{or} \quad \frac{1}{r} \cdot \frac{d}{dr} \left( r \cdot \frac{h^3}{12 \cdot \mu} \cdot \frac{d}{dr} P \right) = V \quad (1) \quad \text{or} \quad \frac{1}{r} \cdot \frac{d}{dr} (-r \cdot q_r) = V$$

where  $q_r$  is the radial flow rate  $q_r = \frac{-h^3}{12 \cdot \mu} \cdot \frac{d}{dr} P$  (2)

A first integral of Reynolds Eqn. is straightforward,  $q_r = -V \cdot \frac{r}{2}$  (3)

Note that  $q_r = 0$  at  $r=0$  because there cannot be any flow in or out of the center of the plates (a uniqueness condition). In addition, the radial flow increases linearly with the radial coordinate, being a maximum at  $r=R$ .

$q_r > 0$ , flow leaves the plates, if  $V = dh/dt < 0$ , that is when the film thickness is decreasing; while there is lubricant inflow.  $q_r < 0$  if  $V > 0$ , when the film thickness is increasing. This last condition occurs if and only if the plates are submerged in a pool of lubricant. Otherwise, air entrains into the film; thus invalidating the major assumption for the analysis.

Substitution of (2) into (3) and integration leads to the pressure field

$$P(r) = P_a - 3 \cdot \mu \cdot \frac{V}{h^3} \cdot (R^2 - r^2) \quad (4)$$

where  $P_a$  is the ambient pressure at the plate boundary,  $r=R$ . Eq. (4) shows that the pressure has a parabolic shape with a peak (max or min) value at the plate center,  $r=0$ .

The peak pressure, above the ambient value is

$$P_{\text{peak}} = -3 \cdot \mu \cdot \frac{V}{h^3} \cdot R^2 \quad (5)$$

Note that the peak pressure  $>0$  if  $V < 0$ , when the film thickness is decreasing

Figures 2 and 3 show details of the pressure profile and exit flow out or into the gap between the plates for the conditions of positive squeeze ( $V < 0$ ) and negative squeeze ( $V > 0$ ), respectively.

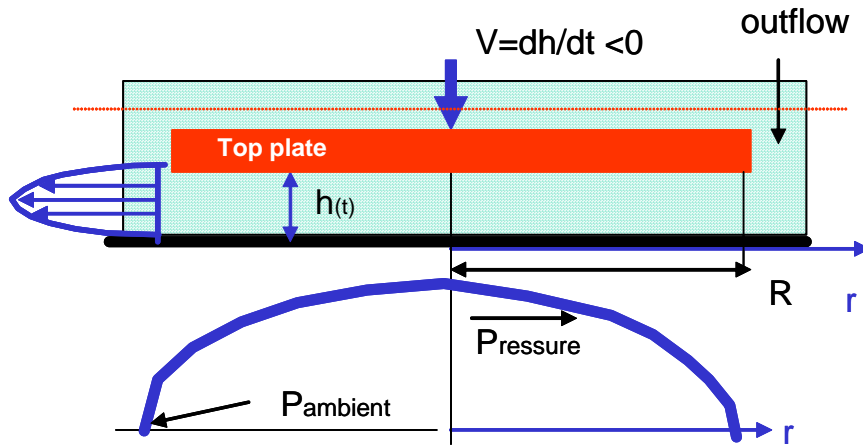

**Fig. 2 Positive squeeze film flow,  $dh/dt < 0$ ,  $P > P_{\text{ambient}}$ , flow leaving gap**

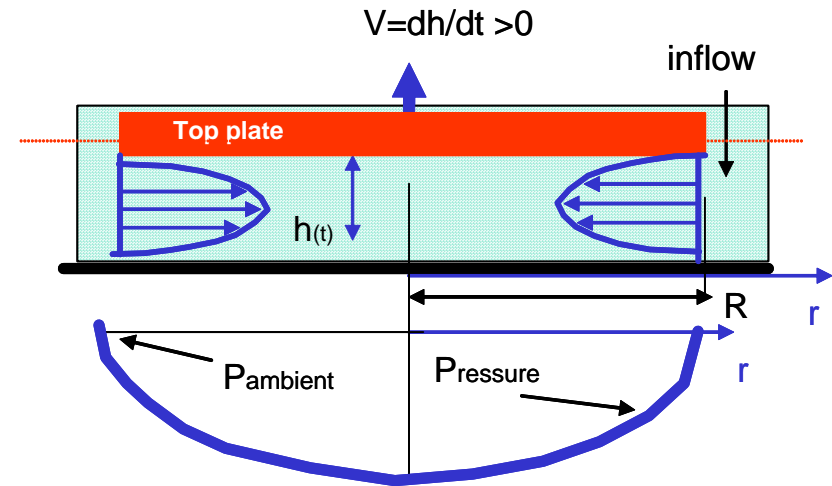

**Fig. 3 Negative squeeze film flow,  $dh/dt > 0$ ,  $P < P_{\text{ambient}}$ , inflow into gap**

The pressure acting on the plates generates a dynamic force,  $F$ , given by

$$F = \int_0^R (P - P_a) \cdot r \, dr \cdot (2 \cdot \pi) \quad (6a)$$

Substitution of (4) into (eq. (6a) renders

$$F = \frac{3}{2} \cdot \pi \cdot \mu \cdot \frac{-V}{h^3} R^4 \quad (6b) \quad \text{where} \quad V = \frac{d}{dt}h \quad \text{and} \quad h(t) \quad \text{are the instantaneous velocity and film thickness}$$

- a)** If  $\underline{V} := 0$  then  $\underline{F} := 0$  a squeeze film cannot generate a force unless  $V \neq 0$
- b)** If  $V < 0$  then  $F > 0$  a support load, opposite to the velocity of approach of both plates  
**(positive squeeze action)**
- c)** If  $V > 0$  then  $F < 0$  a load opposing the velocity of separation of both plates  
**(negative squeeze action)**

Clearly (c) occurs provided there is no lubricant cavitation, since  $P_{\text{peak}} < 0$ . This condition will only happen for sufficiently large ambient pressures. In practice, however, the needed static pressure is too large, and thus impractical to implement.

Consider (top) plate periodic motions with frequency  $\omega$   $h(t) = h_0 + \Delta h \cdot \sin(\omega \cdot t)$

$$\Delta h < h_0$$

in this case,

$$V(t) = \Delta h \cdot \omega \cdot \cos(\omega \cdot t)$$

and the squeeze film reaction force equals

$$F = \frac{3}{2} \cdot \pi \cdot \mu \cdot \omega \cdot \frac{-(\Delta h \cdot \cos(\omega \cdot t))}{(h_0 + \Delta h \cdot \sin(\omega \cdot t))^3} R^4 \quad (7)$$



Define the following dimensionless variables

$$\tau = \omega \cdot t$$
$$\Delta H = \frac{\Delta h}{h_0} \quad F_0 = \frac{3}{2} \cdot \pi \cdot \mu \cdot \omega \cdot \frac{R^4}{h_0^2}$$

then

$$F(\tau) = F_0 \cdot \left[ -\Delta H \cdot \frac{\cos(\tau)}{(1 + \Delta H \cdot \sin(\tau))^3} \right] = F_0 \cdot g(\Delta H, \tau)$$

define

$$g(\Delta H, \tau) := -\Delta H \cdot \frac{\cos(\tau)}{(1 + \Delta H \cdot \sin(\tau))^3}$$

and graph the **dynamic pressure field** for one period of dynamic motion ( $2\pi/\omega$ ). Note how quickly the squeeze film pressure increases as the amplitude  $\Delta H$  grows and approaches  $H=1$ . Furthermore, the film pressure, albeit periodic, has multiple super frequency components as  $\Delta H \gg 0$ .

In the graphs below, note the change in scale (vertical)

$\Delta H_1 := 0.01$   $\Delta H_2 := 0.02$   $\Delta H_3 := 0.03$

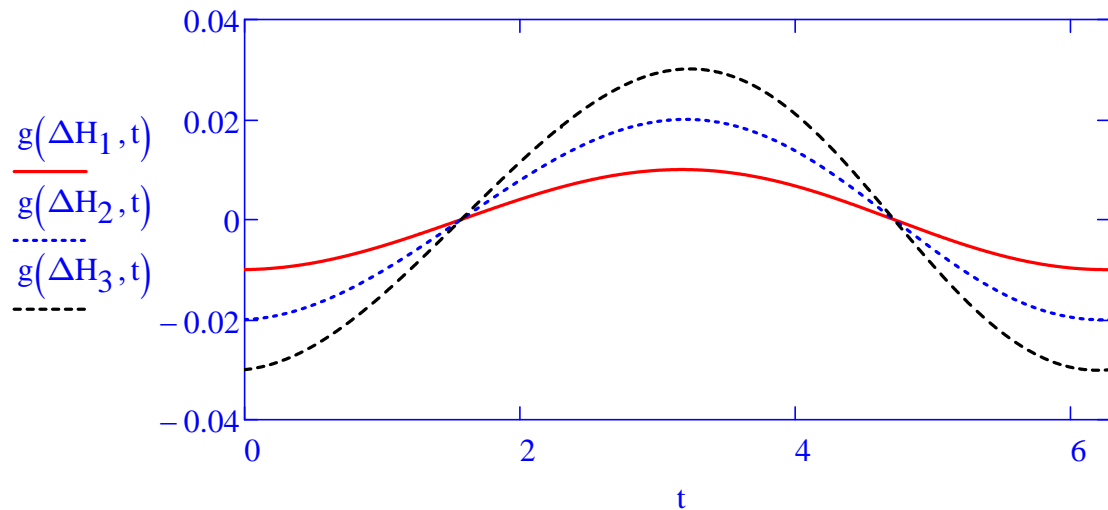

ONE period of motion

$\Delta H_1 := 0.1$   $\Delta H_2 := 0.2$   $\Delta H_3 := 0.3$

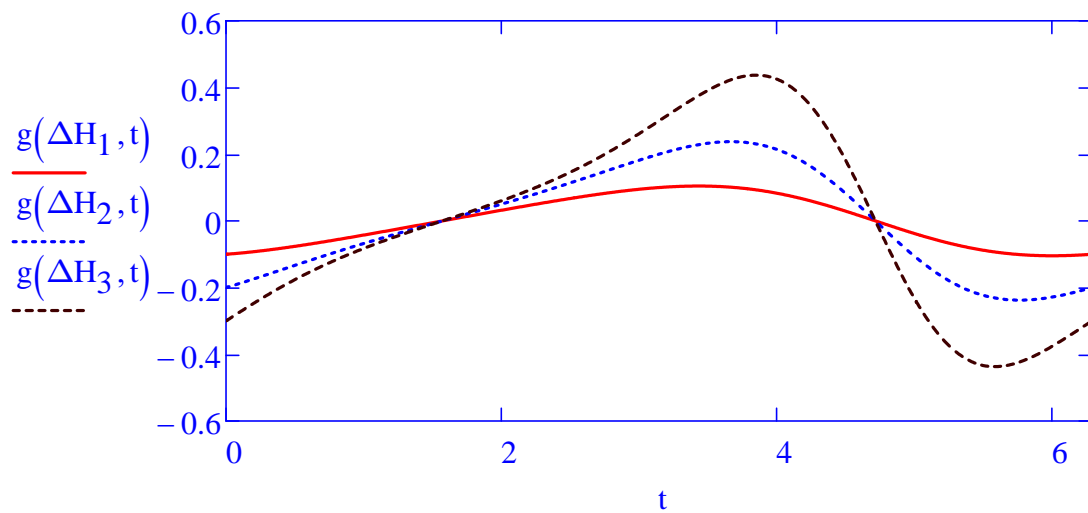

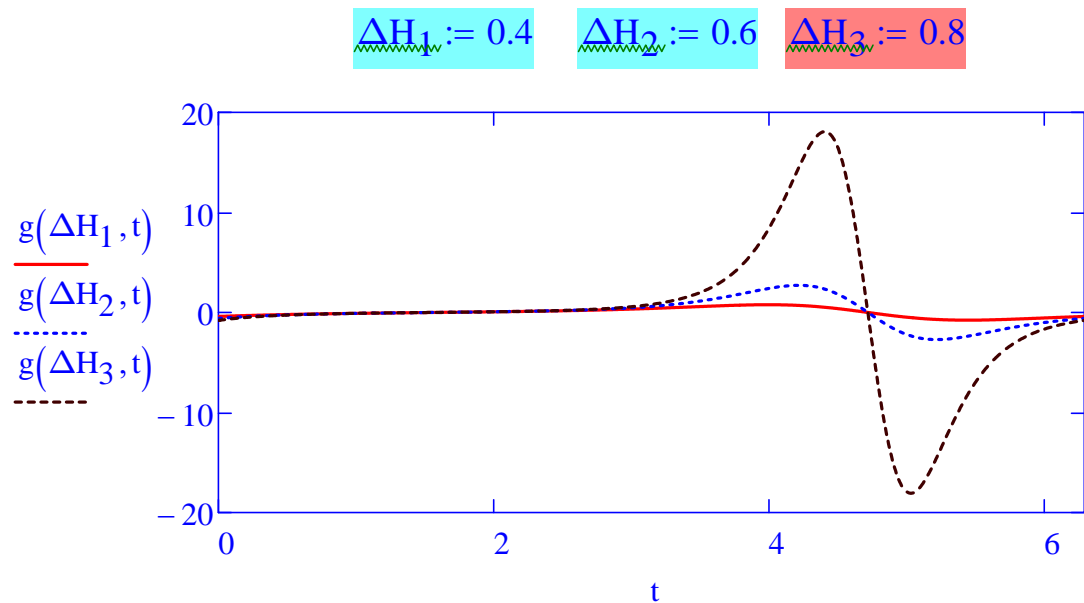

**Closure:**

The analysis above neglects fluid inertia (**a severe omission**) and assumes there is NO air entrainment or fluid cavitation (gaseous or vapor) [**a more severe omission**]