

**MECHANISMS OF ACTION OF NON-STEROIDAL ANTI-INFLAMMATORY DRUGS
(NSAIDs) IN COLON CANCER**

A Dissertation

by

SATYA SREEHARI PATHI

Submitted to the Office of Graduate Studies of
Texas A&M University
in partial fulfillment of the requirements for the degree of

DOCTOR OF PHILOSOPHY

August 2012

Major Subject: Toxicology

**MECHANISMS OF ACTION OF NON-STEROIDAL ANTI-INFLAMMATORY DRUGS
(NSAIDs) IN COLON CANCER**

A Dissertation

by

SATYA SREEHARI PATHI

Submitted to the Office of Graduate Studies of
Texas A&M University
in partial fulfillment of the requirements for the degree of

DOCTOR OF PHILOSOPHY

Approved by:

Chair of Committee,
Committee Members,

Interdisciplinary Faculty
Chair of Toxicology,

Stephen H. Safe
Robert C. Burghardt
Timothy Phillips
Yanan Tian

Weston Porter

August 2012

Major Subject: Toxicology

ABSTRACT

Mechanisms of Action of Non-Steroidal Anti-Inflammatory Drugs (NSAIDs) in Colon Cancer. (August 2012)

Satya Sreehari Pathi, B.V.M., Acharya N. G. Ranga Agricultural University, India;

M.S., Texas A&M University, Kingsville

Chair of Advisory Committee: Dr. Stephen H. Safe

Non-steroidal anti-inflammatory drugs (NSAIDs) and their NO derivatives (NO-NSAIDs), and synthetic analogs are highly effective as anticancer agents that exhibit relatively low toxicity compared to most clinically used drugs. However, the mechanisms of action for NSAIDs and NO-NSAIDs are not well defined and this has restricted their clinical applications and applications for combined therapies. Earlier studies from our laboratory reported that specificity protein (Sp) transcription factors (Sp1, Sp3 and Sp4) are overexpressed in several types of human cancers including colon cancer and many Sp-regulated genes are pro-oncogenic and individual targets for cancer chemotherapy. Based on published results showing that NSAIDs downregulate several putative Sp-regulated genes, we hypothesized that the anticancer properties of NSAIDs may be due, in part, to downregulation of Sp transcription factors.

NSAIDs and nitro derivatives of NSAIDs have been investigated in colon cancer cells and *in vivo* xenograft models. Aspirin and TA induced apoptosis and decreased colon cancer cell growth and tumor growth *in vivo* and downregulated genes associated with cell growth, survival, and angiogenesis. Previous RNA interference studies in this laboratory have shown that many of these genes are regulated, in part, by Sp

transcription factors Sp1, Sp3 and Sp4 that are overexpressed in colon and other cancer cell lines. Not surprisingly, these NSAIDs also decreased Sp1, Sp3 and Sp4 proteins and Sp-regulated gene products in colon cancer cells and this was due to caspase-dependent proteolysis of Sp1, Sp3 and Sp4. Aspirin-induced activation of caspases and degradation of Sp proteins was due to sequestration of zinc and could be reversed by addition of zinc sulphate, whereas TA mediated induction of caspases was independent of zinc ions and is currently being investigated.

GT-094 is a novel NO chimera-containing NSAID, which also inhibited colon cancer cell proliferation and induced apoptosis; these effects were accompanied by decreased mitochondrial membrane potential (MMP) and induction of reactive oxygen species (ROS), and were reversed after cotreatment with the antioxidant glutathione. GT-094 also downregulated Sp and Sp-dependent gene products and was due to decreased expression of microRNA-27a (miR-27a) and induction of ZBTB10, an Sp transcriptional repressor that is regulated by miR-27a in colon cancer cells. Moreover, the effects of GT-094 on Sp1, Sp3, Sp4, miR-27a and ZBTB10 were also inhibited by glutathione suggesting that the anticancer activity of GT-094 in colon cancer cells is due, in part, to ROS-dependent disruption of miR-27a:ZBTB10. The importance of ROS induction in targeting Sp transcription factors was also confirmed using pro-oxidants such as ascorbic acid, hydrogen peroxide and t-butyl hydroperoxide and similar results have been observed in collaborative studies with other ROS inducers in colon cancer cells. Many cancer cell lines and tumors exhibit addiction to non-oncogenes such as Sp1, Sp3 and Sp4 for maintaining the oncogenic phenotype and future research will focus on the mechanisms of ROS-mediated targeting of Sp transcription factors which represents a novel approach for cancer chemotherapy.

DEDICATION

I dedicate my dissertation to my parents Pathi Satya Narayana Vara Prasad and Pathi Venkata Subbamma. They are my strength and without their support I would not stand here. My gratitude and my love to them are beyond words.

ACKNOWLEDGEMENTS

It's my pleasure to thank the many people who made this dissertation possible. Firstly, I would like to express my gratitude to Dr. Stephen Safe, the chair of my advisory committee, for giving me the precious opportunity to work with him and without him; I never would have made it through this challenge. I am very much thankful for his constant support, guidance, and encouragement, which allowed me to venture into new areas and grow as a researcher. He is very understanding, patient and a great person to work with and his precious suggestions will always be remembered.

I would like to thank all my committee members, Dr. Robert Burghardt, Dr. Timothy Phillips and Dr. Yanan Tian, for their scholarly guidance and valuable suggestions during my doctoral program.

I would like to thank my father and mother, Pathi Satya Narayana Varaprasad and Pathi Venkata Subbamma, for giving me courage and strength needed to achieve my goals.

I am deeply grateful to my adorable wife, Mrs. Harika for her consistent support in our newly wedded life. She is awesome and with in short span of wedded life she made an impact in my life. I love her very much. My heartfelt thank to her for helping me in writing this dissertation.

I also want to thank my brothers, Pathi Satya Srinivasulu and Pathi Satya Manohar, for their love and encouragement through all my endeavors. I must also, thank my sister-in-laws, Haritha and Vijaya and and my chirpy toddlers, Chinnu and Minnu.

I would also like to mention the love and care from my mother-in-law Gundlapalli Padmavathi and my father-in-law Gundlapalli Venkateswra Prasad and brother-in-law, Gundlapalli Jagadeesh.

I would like to extend my thanks to all Safe lab members Indira Jutooru and Gayathri Chadalapaka, Xi Li, Sandeep Sreevalsan, Vijaya lekshemi, Shane for their constant support and help during my research, and my special thanks to Sudhakar Chintarllapalli and Sabitha Papineni for helping me to join this lab.

I also want to thank my dearest friends Subbu, Ram, Praveena and Radhika for their friendship. I also take this opportunity to thank Dr. Jagadeesh for being helpful and for his moral support. A special thanks to Lorna Safe, Kathy Mooney, and Kim Daniel. Finally I thank the almighty for providing me strength and courage to be successful in all my endeavors.

TABLE OF CONTENTS

		Page
ABSTRACT		iii
DEDICATION		v
ACKNOWLEDGEMENTS		vi
TABLE OF CONTENTS.....		viii
LIST OF FIGURES		x
LIST OF TABLES		xiv
CHAPTER		
I	INTRODUCTION.....	1
	Cancer.....	1
	Colon cancer	14
	Epigenetic changes in colon cancer.....	29
	Inflammation and colorectal cancer	34
	Diagnosis and staging of colorectal cancer	49
	Treatment of colorectal cancer.....	52
	Mechanism based anticancer drugs	56
	Transcription factors as drug targets.....	68
	Specificity protein (Sp) transcription factors as drug targets.....	74
	NSAIDs as anti-cancer agents.....	85
	NO-NSAIDs and cancer.....	100
	Ascorbic acid and cancer.....	108
II	ASPIRIN INHIBITS COLON CANCER CELL AND TUMOR	
	GROWTH AND DOWNREGULATES SPECIFICITY	
	PROTEIN (Sp) TRANSCRIPTION FACTORS.....	116
	Introduction.....	116
	Materials and methods	118
	Results	123
	Discussion	137

CHAPTER	Page
III	TOLFENAMIC ACID (TA) INHIBITS COLON CANCER CELL AND TUMOR GROWTH AND DOWNREGULATES SPECIFICITY PROTEIN (Sp) TRANSCRIPTION FACTORS 142
	Introduction..... 142
	Materials and methods 144
	Results 147
	Discussion 158
IV	GT-094, A NO-NSAID, INHIBITS COLON CANCER CELL GROWTH BY ACTIVATION OF A REACTIVE OXYGEN SPECIES (ROS)-MICRORNA-27A:ZBTB10-SPECIFICITY PROTEIN (Sp) PATHWAY 162
	Introduction..... 162
	Materials and methods 164
	Results 169
	Discussion 180
V	PHARMACOLOGIC DOSES OF ASCORBIC ACID REPRESS SPECIFICITY PROTEIN (Sp) TRANSCRIPTION FACTORS AND Sp REGULATED GENES IN COLON CANCER CELLS..... 184
	Introduction..... 184
	Materials and methods 186
	Results 189
	Discussion 200
VI	SUMMARY 204
	REFERENCES 208
	VITA 269

LIST OF FIGURES

FIGURE	Page
1.1 Leading new cancer cases and deaths according to 2012 estimates	3
1.2 Different stages of carcinogenesis.....	4
1.3 Contribution of EMT to cancer progression and metastasis.....	8
1.4 Characteristic futures of malignant cell.....	9
1.5 Development of CRC and CAC; adenoma-carcinoma sequence.....	18
1.6 Schematic representation of APC and mutations in APC	19
1.7 Model of APC and β -catenin in Wnt canonical signaling.....	21
1.8 Epigenetic mechanisms in colorectal cancer	29
1.9 Northern blot analysis of miRNAs miR-25 and miR-92	33
1.10 Comparison of the carcinogenesis pathways associated with sporadic colorectal cancer and colitis-associated colorectal cancer	38
1.11 Regulation of NF- κ B activity by tumor suppressors	41
1.12 Role of NF- κ B in gastric and colorectal cancers	42
1.13 Western blots showing COX-2 protein levels (72-kilodalton band) in paired tissues from sporadic CRCs (T) and normal mucosa (N) (left panel)	44
1.14 Crosstalk of PGE2 with other signaling networks during colorectal cancer Progression.....	46
1.15 Signalling crosstalk between inflammatory cells and tumor cells	49
1.16 VEGF signalling pathway	61
1.17 EGFR signalling pathway	64
1.18 Transcription factors are attractive targets for cancer treatment	71
1.19 The zinc fingers of Sp/KLF transcription factors	75

1.20	Structural motifs in Sp family proteins	76
1.21	Sp dependent transactivation in cancer cells.....	80
1.22	Strategies for targeting Sp proteins in cancer cells	83
1.23	Chemical structures of commonly used NSAIDs	85
1.24	NSAIDs, COX inhibition and prostaglandins	86
1.25	COX2-depenedent and –independent mechanisms of NSAID induced apoptosis	89
1.26	NSAIDs and non-COX targets.....	92
1.27	The structure of TA	98
1.28	The chemical structure of NO-aspirin	100
1.29	The structure of representative NO-NSAIDs.....	101
1.30	Mechanism of gastric cytoprotection by NO-NSAIDs.....	102
1.31	Working model of the effect of nitric oxide (NO)-donating aspirin on signaling pathways and other molecular targets	105
1.32	Structure of GT-094.....	107
1.33	Different states of ascorbic acid	109
1.34	Comparison of survival times in patients administered with or without ascorbate	110
1.35	Anticancer effects of ascorbate in cancer patients.....	111
1.36	Proposed mechanism for formation of Asc ^{•-} and H ₂ O ₂ in extracellular fluid compared with blood.....	114
2.1	Aspirin inhibits colon cancer cell growth and induces apoptosis	124
2.2	Aspirin decreases expressions of Sp1, Sp3, Sp4 and Sp-regulated gene products in colon cancer cells	126
2.3	Salicylate inhibits colon cancer cell growth and downregulates Sp1, Sp3, Sp4 and Sp-regulated genes	127

2.4	Aspirin decreases expression of NF κ B and β -catenin in colon cancer cells.....	129
2.5	Knockdown of Sp1, Sp3 and Sp4 (alone and combined) by RNA.....	131
2.6	Mechanisms of aspirin-induced Sp protein degradation	133
2.7	Zinc depletion results in downregulation of Sp proteins	134
2.8	Aspirin inhibits colon tumor growth in athymic nude mice (xenografts)	136
3.1	Tolfenamic acid inhibits colon cancer cell growth and induces apoptosis	149
3.2	Western blot analysis of Sp-regulated survival and Sp proteins in colon cancer cells.....	150
3.3	Western blot analysis of Sp-regulated angiogenic and proliferative proteins in colon cancer cells	152
3.4	Tolfenamic acid inhibits colon tumor growth in athymic nude mice (xenografts)	153
3.5	Mechanisms of tolfenamic acid -induced Sp protein degradation	155
3.6	Mechanisms of tolfenamic acid-induced Sp protein degradation	156
4.1	GT-094 inhibits growth and induces apoptosis in colon cancer cells	170
4.2	GT-094-mediated effects on Sp protein and Sp-regulated gene products	171
4.3	GT-094 decreases MMP in colon cancer cells.....	173
4.4	Role of ROS in GT-094-mediated downregulation of Sp1, Sp3 and Sp4 proteins.....	175
4.5	GSH blocks GT-094-induced growth inhibition and apoptosis	176
4.6	GT-094 modulates miR-27a and ZBTB10 expression	178
4.7	Time course effects of GT-094 on miR-27a.....	179
5.1	Ascorbate is cytotoxic to colon cancer cells. A: Cell growth inhibition.....	191
5.2	Ascorbate-induced effects on proteins involved in cell growth and cell death.....	193

5.3	Ascorbate, H ₂ O ₂ , and <i>t</i> -butylhydroperoxide (T-BOOH) downregulate specificity protein (Sp)1, Sp3, and Sp4.....	194
5.4	Antioxidants inhibit ascorbate-induced ROS and growth inhibition	196
5.5	Antioxidants inhibit ascorbate-induced repression of specificity protein (Sp)1, Sp3, Sp4, and Sp-regulated gene products	197
5.6	Antioxidants block H ₂ O ₂ - and T-BOOH-induced responses in colon cancer cells.....	199

LIST OF TABLES

TABLE	Page
1.1 Molecular genetics of inherited colorectal cancer syndromes	15
1.2 Promoter CpG island hypermethylated genes in colorectal cancer	31
1.3 Incidence of large bowel neoplasms in mice treated with AOM and various doses of DSS	36
1.4 TNM classification of colorectal cancer based on clinical and pathological conditions	51
1.5 Correlation between TNM stage and 5-year survival in colorectal carcinoma	52
1.6 Available drugs for the treatment of metastatic colon cancer	57
1.7 Hallmark characteristics of transcription factors	70
1.8 Summary of preclinical studies involving transcription factors as drug targets	72
1.9 Comparison of different technologies in targeting TF's	74
1.10 Effects of COX-2 selective inhibitors in animal models of colorectal cancers	88
1.11 Tumor cell growth and COX inhibitory activity of different NSAIDs	91
1.12 Growth inhibitory IC ₅₀ values of NSAIDs and NO-NSAIDs in colon cancer cells	104

CHAPTER I

INTRODUCTION

CANCER

Cancer is a group of diseases in which cells begin to proliferate in the absence of control and cancer cells typically exhibit increased growth and survival compared to normal cells. Cancer cells in one tissue can metastasize to other tissues/organs and this eventually leads to cancer related mortality. Cancer is a leading cause of death worldwide and deaths from cancer are projected to continue to increase, with an estimated 13.1 million deaths in 2030. In 2008, worldwide cancer deaths were nearly 7.6 million and this accounted for 13% of all deaths and more than 12 million people were diagnosed with cancer.

The most commonly diagnosed cancers worldwide are lung (1.61 million, 12.7% of the total), breast (1.38 million, 10.9%) and colorectal cancers (1.23 million, 9.7%). The highest incidence of cancer deaths are from lung cancer (1.38 million, 18.2% of the total), stomach cancer (738,000 deaths, 9.7%) and liver cancer (696,000 deaths, 9.2%) and approximately 70% of all cancer deaths occur in low- and middle-income countries [1]. Cancer is the second highest cause of deaths in the US after heart disease and it accounts for 1 of every 4 deaths. In 2012, approximately 1,638,910 new cancer cases are expected to be diagnosed and 577,190 Americans are expected to die of cancer, i.e., more than 1,500 people a day (Fig. 1.1) [2].

This dissertation follows the style of Carcinogenesis.

The National Cancer Institute estimates that nearly 12 million Americans with a history of cancer were alive in January 2008 and some of these individuals were cancer-free, while others still had evidence of cancer and may be undergoing treatment. Since the risk of being diagnosed with cancer increases with age, most cases occur in middle aged or older people. About 77% of all cancers are diagnosed in persons 55 years of age and older. Cancer researchers use the word “risk” in different ways, most commonly expressing risk as lifetime risk or relative risk. *Lifetime risk* refers to the probability that an individual will develop or die from cancer over the course of a lifetime.

In the US, men have slightly less than a 1 in 2 lifetime risk of developing cancer; for women, the risk is a little more than 1 in 3. *Relative risk* is a measure of the strength of the relationship between risk factors and a particular cancer. It compares the risk of developing cancer for persons with a certain exposure or trait to the risk in persons who do not have this characteristic. For example, male smokers are about 23 times more likely to develop lung cancer than nonsmokers, so their relative risk is 23. Most relative risks are not this large. For example, women who have a first-degree relative (mother, sister, or daughter) with a history of breast cancer have about twice the risk of developing breast cancer, compared to women who do not have this family history.

Leading New Cancer Cases and Deaths – 2012 Estimates

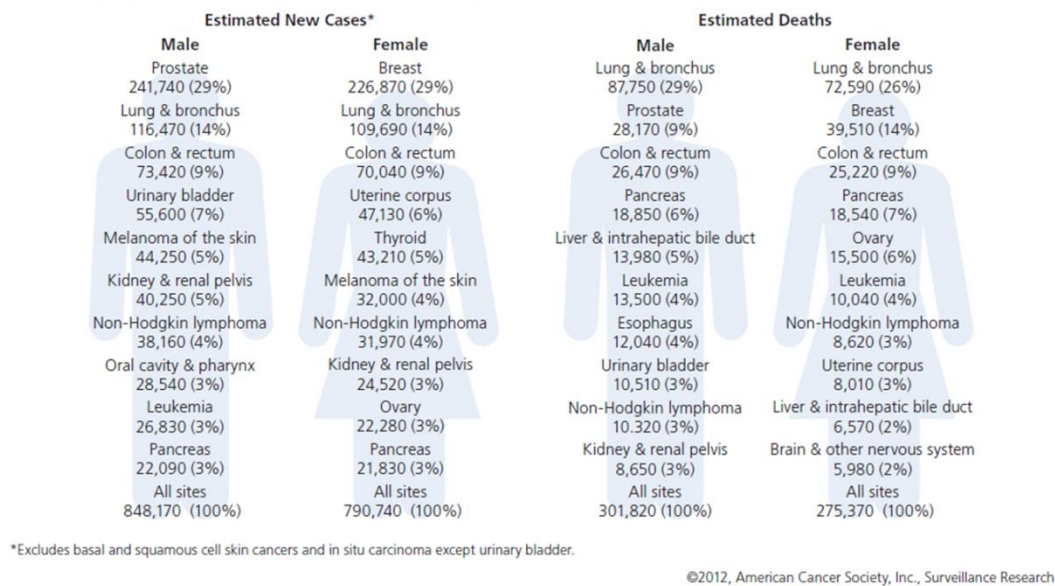

Fig.1.1. Leading new cancer cases and deaths according to 2012 estimates [2].

All cancers involve the malfunction of genes that control cell growth and division. About 5% of all cancers are strongly hereditary, in that an inherited genetic alteration confers a very high risk of developing one or more specific types of cancer. However, most cancers do not result from inherited genes but from damage to genes occurring during one's lifetime. Genetic damage may result from internal factors, such as hormones or the metabolism of nutrients within cells, or external factors, such as tobacco, chemicals, and excessive exposure to sunlight. These causal factors may act together or in sequence to initiate or promote the development of cancer. Ten or more years often pass between exposure to external factors and detectable cancer. Most importantly, development of cancer is due to genetic abnormalities in two classes of genes namely oncogenes and tumor suppressor genes. The first identified oncogenes were of viral origin with variable cellular functions ranging from their role as

transmembrane protein receptors to nuclear transcription factors. Tumor oncogenes are constitutive and activated by mutations and enhance cell proliferation and transformation, while tumor suppressor genes regulate apoptosis and cell division and are repressed in cancer cells.

Mechanisms of Carcinogenesis. Carcinogenesis is the general term used for the development of cancer; and several well known cancer models show that tumor formation is a multistep process that can be categorized into different stages namely, initiation, promotion, progression, invasion and metastasis (Fig 1.2).

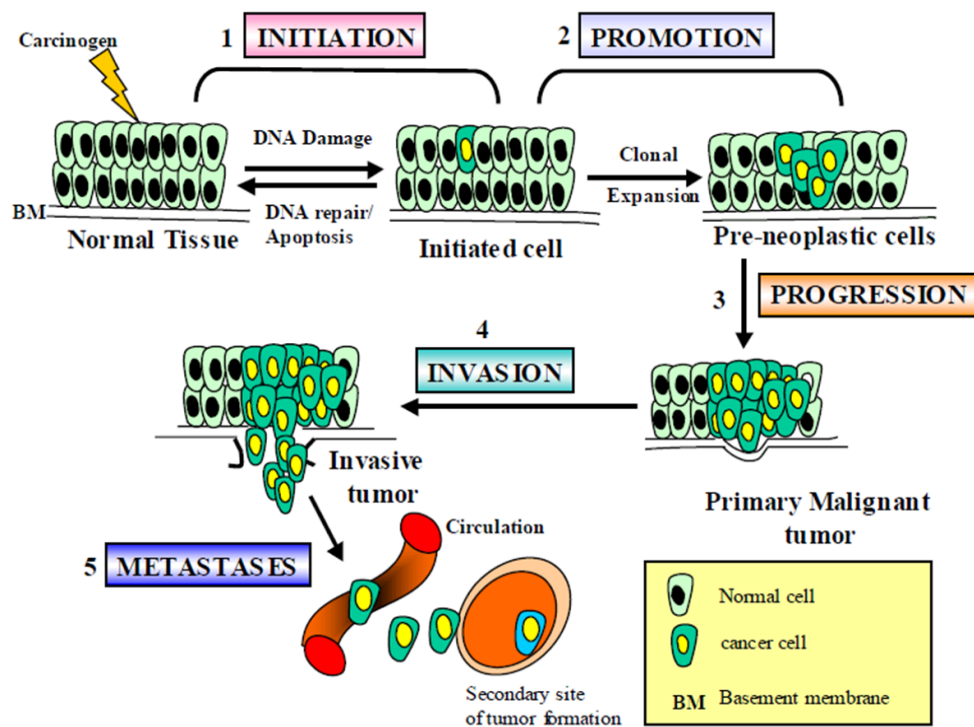

Fig. 1.2. Different stages of carcinogenesis [3].

Initiation is the first stage of carcinogenesis and results from several studies indicate that initiation is caused by irreversible genetic changes which predispose susceptible normal cells to become malignant and immortalized. However, the efficiency of cancer initiation depends on cellular replicative DNA synthesis and cell division. DNA synthesis is primarily required for the fixation and the irreversibility of the initiated state [4, 5]. Genetic changes or DNA damage can result from ionizing radiation such as X-rays, chemical carcinogens and viruses like papilloma virus and Epstein-Barr virus. Exposure to mutagens does not cause observable changes in the cellular phenotype but increases the susceptibility for cancer formation. Several different models of cancer initiation have been proposed.

For example, mouse skin carcinogenesis involves genetic damage due to formation of covalent adducts between mutagens and DNA and these mutations are also observed in critical stem cell genes. Mutations of Ha-ras and N-ras oncogenes are responsible for development of benign papillomas and few papillomas become malignant squamous cell carcinomas (SCC) [6]. There is ample evidence that p53 acts as a tumor suppressor gene and mutations of p53 due to ultraviolet B radiation results in initiation of skin tumors in mouse models and humans [7, 8]. Loeb *et al.*, [9] have proposed mutator phenotype hypothesis for initiation and suggest that the normal rate of mutations does not correlate with the number of mutations observed in cancer cells. It is hypothesized that mutations of genes involved in DNA synthesis, DNA repair, cell cycle, progression and apoptosis will amplify the basal mutation rate and are responsible for tumor initiation and promotion in a multi-hit model of carcinogenesis.

Tumor promotion is the second stage of carcinogenesis in which an initiated cell with mutations expands clonally and several pathways are involved in the promotion of

carcinogenesis. Induction of continuous proliferation and hyperplasia by direct activation of mitotic signaling pathways or indirectly in response to chronic wounding and/or inflammation, or due to a block in terminal differentiation or resistance to apoptosis is necessary to allow clonal expansion of mutated initiated cells to form tumors. In mouse models of carcinogenesis, tumor promotion involves mitotic pathways such as activation of epidermal growth factor receptor (EGFR) and Ras/Raf/mitogen-activated protein kinase (MAPK) signaling. Chronic inflammation results in inflammatory cell secretion of growth factors and cytokines such as tumor necrosis factor- α (TNF- α) and interleukins, as well as production of reactive oxygen species (ROS), all of which can stimulate cell proliferation. Persistent activation of these pathways leads to tumor promotion [10], which is dependent on favorable factors for cell growth such as tumor cell-stromal interactions, growth factors, angiogenesis, oxygen and many other factors. Even though DNA damage check points and apoptosis pathways may be activated by genetic events during initiation; >50% of human cancers are defective in these pathways due to mutations in tumor suppressor genes such as p53, retinoblastoma (Rb), which regulate proapoptosis [11].

There are number of tumor promoters including phorbol esters, phenobarbitol, peroxisome proliferators, and biphenyls, many of which reversibly inhibit gap junctions [12]. A tumor promoter must be administered for weeks, months and even years and its effectiveness depends on the concentration in the target tissue. Tumor promotion is also reversible and after stopping promotion, cell growth decreases and apoptosis is increased. All cells exposed to promoters do not take part in the promotion stage, while cells that are stimulated to divide, undifferentiated and survive apoptosis can contribute to instability and result in malignant neoplasia [13].

Tumor progression is the third stage of carcinogenesis in which preneoplastic and/or benign neoplastic cells are transformed into malignant lesions. The stage of progression is characterized by its karyotypic instability and development of irreversible, aneuploid malignant neoplasms which distinguishes tumor progression from both initiation and promotion [14]. These genomic alterations in neoplastic cells during progression are directly related to increased cell growth, invasiveness, metastatic instability and changes in the biochemical, morphological and physiological characteristics of the cells [15]. Angiogenesis is essential for neoplastic progression and contributes to malignancy and inhibition of angiogenesis delays neoplastic development [16]. Karyotypic alterations continue during progression in a variety of different neoplasms, such as multistage epidermal carcinogenesis, leukemia, lymphoma, hepatocarcinogenesis and colorectal carcinogenesis [17, 18].

Vogelstein *et al.*, proposed a classical model of tumor progression in colorectal cancer progression, which involves successive waves of clonal selection [19]. According to this model, genetic alterations cause permanent genetic instability with high rate of chromosomal or base modification resulting in morphological and karyotypic changes that transform pre-neoplastic cells into neoplastic cells [20]. In colorectal cancers, there is a good correlation between gene mutations such as loss of chromosomes 8p and 18q and the severity of the disease measured by disease free survival at five years after surgery [21].

Invasion and metastasis is fourth stage of carcinogenesis. The major reason for most cancer deaths is not due to the primary neoplasms, but secondary tumors metastasized to other sites. Drastic phenotypic and biochemical changes occur during

the metamorphosis of a normal cell into an invasive cancer cell due to changes in growth factor signaling, cell-cell adhesion, gene expression, motility or cell shape [22].

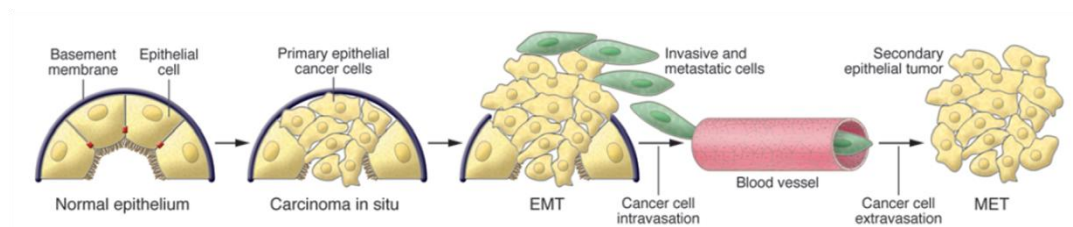

Fig. 1.3. Contribution of EMT to cancer progression and metastasis [23].

Invasive cancer cells can secrete proteases which lyse barriers such as basement membranes in host cells and thereby facilitate migration of tumor cells to distant sites and angiogenesis at these sites [24]. Cancer cells of epithelial origin can adopt a mesenchymal-like phenotype and this is often referred to as an epithelial-mesenchymal transition (EMT) which contributes to their metastatic phenotype (Fig. 1.3). Various oncogenes, tumor suppressor genes and metastasis suppressor genes can affect the invasiveness and the metastatic potential of tumor cells. Due to the loosening of tissue structure as well as changes in the cytoskeleton such as the loss of cell adhesion molecules (CAM) and changes in integrin expression, epithelial cells may adopt a mesenchymal character. Dysregulation of the cadherin family and particularly the loss of E-cadherin and upregulation of N-cadherin are commonly observed in invasive cancer cells [23, 25]. The E-cadherin gene CDH-1 is also referred to as a metastasis suppressor gene, and loss of CDH1 induces an invasive phenotype in immortalized cells [26]. Cells of the innate and adaptive immune system, adjacent

stromal cells as well as chemokines and their receptors also play an important role in cancer cell metastasis and the tumor micro-environment, vascularization and the supply of cytokines also affect EMT.

It has recently been suggested that tumors consist of two types of cells – transit amplifying cells and cancer stem cells. Only cancer stem cells can proliferate indefinitely and these cells may play a critical and possibly essential role in tumor metastases [27]. Hanahan and Weinberg have six hallmarks of cancer (Fig. 1.4) that include sustained proliferative signaling, evading growth inhibitors, resisting apoptosis, enabling replicative immortality, sustained angiogenesis and tissue invasion and metastasis [28]. Recently two additional hallmarks of cancer namely reprogramming of energy metabolism and evading immune destruction are now considered as important determinants for cancer progression [28] and these are discussed below.

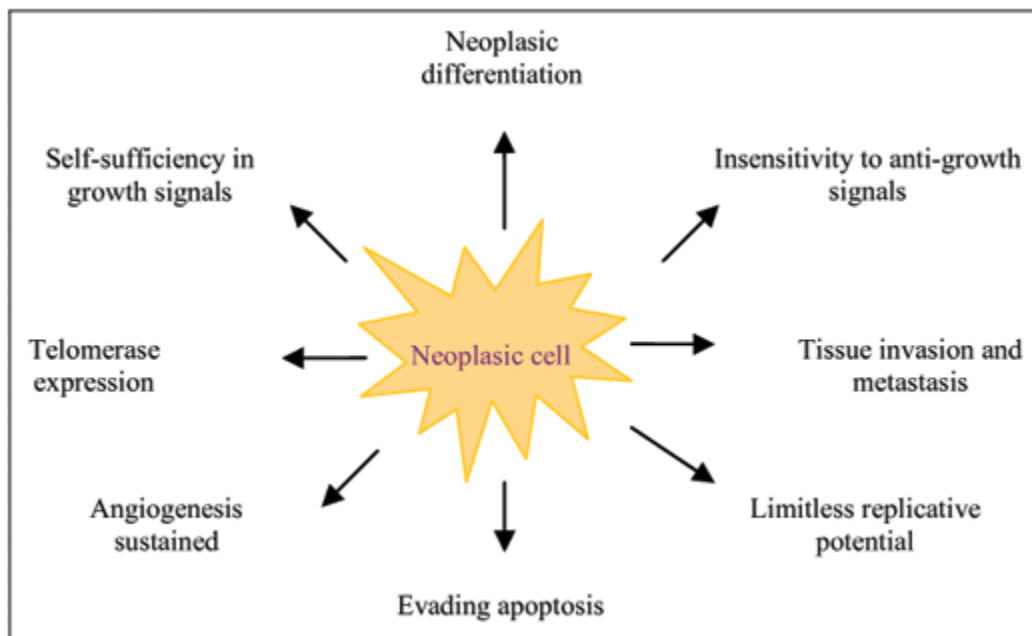

Fig.1.4. Characteristic features of malignant cell [29].

Sustained proliferative signaling. The most important trait of cancer cells is their ability for sustained proliferative signaling through a number of different pathways. Cancer cells can also stimulate growth of normal cells within the tumor microenvironment and these cells secrete various growth factors that enhance cancer cell growth [30]. Overexpression of membrane growth factor receptors can also lead to enhanced cell proliferation; for example EGFR tyrosine kinase is overexpressed, amplified and dysregulated in many cancers and this receptor can engage in autocrine signaling and crosstalk with other kinase signaling cascades [31]. Somatic mutations also contribute to activation of signaling pathways usually activated by growth factor receptors. For example mitogen activated protein kinase (MAPK) pathway and phosphoinositide 3-kinase (PI3K) are constitutively activated in many tumor types due to activating mutations in B-Raf and the catalytic subunit of PI3K respectively [32, 33].

Evading growth inhibitors. Cancer cells can also circumvent powerful programs that negatively regulate cell proliferation and many of these programs include tumor suppressor genes. Two prototypical tumor suppressor genes, Rb and TP53 control two key cellular regulatory networks and govern the decisions of cells to proliferate or activate senescence and apoptosis. The Rb protein integrates signals from various extracellular and intracellular sources, while TP53 receives input from stress and abnormality sensors that decide whether a cell should or should not undergo cell cycle progression [34]. Cancer cells with defects in Rb and TP53 lose the services of these critical gate keepers of cell cycle progression and this result in continuous cell proliferation. For example, chimeric mice lacking the Rb gene exhibit proliferative abnormalities and continuous cell cycle progression leading to neoplasias, particularly

in the pituitary gland. TP53 null mice also develop abnormalities later in life in the form of leukemias and sarcomas [35, 36].

Resisting apoptosis. The concept of programmed cell death by apoptosis serves as a natural barrier to development of cancer and resistance to apoptosis is considered as an important hallmark of cancer. Tumor cells develop many strategies to circumvent apoptosis and most common among them is loss of TP53 tumor suppressor function, which eliminates the DNA damage sensor from inducing apoptosis. TP53 inhibits cell division by terminating the cell cycle at G1 or interphase for repair and in case of extensive DNA damage p53 activates apoptosis [37]. Inactivation of TP53 or TP53-dependent genes leads to inhibition of apoptosis and formation of tumors. In addition cancer cells also inhibit apoptosis by overexpression of antiapoptotic regulators (bcl-2, Bcl-X_L), survival signals (survivin, Igf1/2), and downregulation of proapoptotic factors (Bax, Bim, Puma) [38]. The multiplicity of pathways for inhibition of apoptosis in cancer cells demonstrates the importance of apoptosis inhibition as a hallmark of the progression of cells to malignancy.

Enabling replicative immortality. Cancer cells require unlimited replicative potential in order to generate macroscopic tumors in contrast to non-cancer cells which usually have a definitive replicative potential. After a certain number of divisions, cells stop dividing and enter into nonproliferative viable state of senescence and/or crisis/apoptosis. Occasionally, cells emerge from a population in crisis and exhibit unlimited replicative potential and this transition is termed as immortalization and is well established in cell lines which proliferate in culture without senescence or crisis. Several studies indicate that telomeres which are repeat sequences at the end of chromosomes play an important role in cell replication. It is clear that all types of malignant cells and

90% of human cancers exhibit increased telomerase activity and addition of hexanucleotide repeats to the ends of telomeric DNA [39]. Telomere knockout mice have shortened telomeres and also shunt premalignant cells into senescence resulting in decreased tumorigenesis in mice that are genetically destined to develop cancer [40]. In human breast cancers, transient telomere deficiency results in malignant progression, while premalignant tumors did not express significant levels of telomerase and were characterized by shortening of telomeres and nonclonal chromosomal aberrations [41].

Sustained angiogenesis. Angiogenesis is required for physiological processes such as wound healing and female reproductive cycle, but only transiently. In contrast, during tumor development, angiogenesis is activated and continues to produce new blood vessels that facilitate neoplastic growth [42]. Angiogenesis is regulated by signaling proteins that binds to stimulatory or inhibitory cell surface receptors in vascular endothelial cells. For example vascular endothelial growth factor (VEGF) and fibroblast growth factor (FGF) regulate angiogenesis by binding to cell surface including VEGF-receptor1 (VEGFR1) [43]. Many human tumors including renal and pancreatic adenocarcinomas are highly angiogenic and densely vascularized; tumors also overexpress VEGF and FGF compared to normal tissue and endogenous inhibitors of angiogenesis like thrombospondin, tumstatin are downregulated [44]. In some tumors, dominant oncogenes such as Ras and Myc upregulate expression of angiogenic factors, while in other tumors immune inflammatory cells induce angiogenesis. The direct induction of angiogenesis by oncogenes that also drive proliferative signaling indicates that distinct hallmark capabilities can be coregulated by some transcription factors. The VEGF gene is also regulated by different transcription factors and the role

of specificity protein (Sp) transcription factors in the regulation of VEGF has been reported in several cancers [45, 46].

Activating invasion and metastasis. Tissue invasion and metastasis is a hallmark for advanced stages of cancer with poor patient prognosis. In many human cancers 90% of cancer deaths are associated with invasion and metastasis and this phase is characterized by EMT, loss of cell adhesion, gain of motility and stromal proteolysis [47]. Loss of E-cadherin and upregulation of N-cadherin is a prominent feature of EMT and is observed in most of the metastatic tumors. Epidermal growth factor (EGF)-mediated downregulation of focal adhesion kinase (FAK) is required for early dissemination and cell detachment from the primary tumor. At distant sites, interactions with extracellular matrix through integrins activate FAK and mediate cell attachment which is required for establishing metastatic tumors. Matrix metalloproteases (MMPs) are stromal proteases that facilitate tumor invasion both in vitro and in vivo. Overexpression of urokinase plasminogen activator (uPA) positively correlates with invasive potential for a variety of human cancers because uPA plays an important role in tumor invasion and metastasis by initiating proteolytic cascades [48].

After cancer cells are established at a distant site, they will not receive the same signals from their new environment. Hence, mesenchymal-epithelial-transition (MET, reversal of EMT) is induced and the original phenotype is adopted. Several factors such as TGF- β s, TNF- α , EGF, HGF, IGF-1, E47/e2A, FOXC2, Goosecoid, Snail, Slug, and Twist are known to induce the EMT [49]. Genomic instability and tumor promoting inflammation are also the enabling characteristics that facilitate evolving populations of premalignant cells to become malignant and metastatic.

COLON CANCER

Every year more than one million people will develop colorectal cancer (CRC) worldwide and the specific mortality of this disease is approximately 35% in the developing world. CRC is the 3rd most common malignancy and 4th most common cause of cancer mortality worldwide [50]. It was predicted that there will be approximately 1,000,000 new cases diagnosed in 2008, resulting in nearly 500,000 deaths. CRC is major public health problem in the United States and nearly 150,000 people are diagnosed with CRC every year and approximately one third of them die from the disease [51]. In the United States, among all cancers CRC incidence and mortality are 3rd and 2nd respectively. The lifetime risk for colorectal cancer life time is 6% in the US and the average age of diagnosis of this disease is 66 years [52]. The causes of CRC and its mechanism of pathogenesis are complex and heterogeneous. Diet and lifestyle factors, somatic and hereditary mutations contribute to the development of CRC and risk factors include diets rich in unsaturated fats, processed meat & red meat, total energy intake & reduced physical activity, tobacco and excessive alcohol consumption. Most cases of CRC occur sporadically and contributing factors include increasing age, male sex, previous chromosome polymorphisms and family history of CRC [53].

Inflammatory diseases such as Inflammatory bowel disease and ulcerative colitis are important risk factors for development of CRC and the risk increase with the duration of illness, severity and extent of inflammation [54, 55]. Inflammation induced CRC and sporadic CRC exhibit comparable similarities such as chromosomal (85%) and microsatellite instabilities (15%). Despite these similarities there are important differences between inflammation and sporadic-induced CRC. For example activation of

protooncogenes such as Ras and the inactivation of tumor suppressor genes such as adenomatous polyposis coli (APC) and p53 are important in the development of the majority of CRC, however the frequency and timing of these genetic alterations differ remarkably in sporadic CRC and colitis associated CRC [56, 57].

Table. 1.1. Molecular genetics of inherited colorectal cancer syndromes [58].

Syndrome	Common features	Gene defects
FAP	Multiple adenomatous polyps (>100) and carcinomas of the colon and rectum; duodenal polyps and carcinomas; fundic gland polyps in the stomach; congenital hypertrophy of retinal pigment epithelium	<i>APC</i> (>90%)
Gardner syndrome	Same as FAP; also, desmoid tumors and mandibular osteomas	
Turcot's syndrome	Polyposis and colorectal cancer with brain tumors (medulloblastomas); colorectal cancer and brain tumors (glioblastoma)	<i>APC</i> <i>MLH1</i> , <i>PMS2</i>
Attenuated adenomatous polyposis coli	Fewer than 100 polyps, although marked variation in polyp number (from ~5 to >1,000 polyps) observed in mutation carriers within a single family	<i>APC</i> (predominantly 5' mutations)
Hereditary nonpolyposis colorectal cancer	Colorectal cancer without extensive polyposis; other cancers include endometrial, ovarian and stomach cancer, and occasionally urothelial, hepatobiliary, and brain tumor	<i>MSH2</i> <i>MLH1</i> <i>PMS2</i> <i>GTBP</i> , <i>MSH6</i>
Peutz-Jeghers syndrome	Hamartomatous polyps throughout the GI tract; mucocutaneous pigmentation; increased risk of GI and non-GI cancers	<i>LKB1</i> , <i>STK11</i> (30–70%)
Cowden disease	Multiple hamartomas involving breast, thyroid, skin, central nervous system, and GI tract; increased risk of breast, uterus, and thyroid cancers; risk of GI cancer unclear	<i>PTEN</i> (85%)
Juvenile polyposis syndrome	Multiple hamartomatous/juvenile polyps with predominance in colon and stomach; variable increase in colorectal and stomach cancer risk; facial changes	<i>DPC4</i> (15%) <i>BMPR1a</i> (25%) <i>PTEN</i> (5%)

Among the hereditary colorectal cancers (Table. 1.1), the Lynch syndrome also known as Hereditary Non Polyposis Colorectal Cancer (HNPCC), occurs approximately in one in 300 people with colorectal cancer. Familial adenomatous polyposis (FAP) is a hereditary CRC due to defects in the APC gene; the frequency of FAP is approximately one in 7000 people, whereas other syndromes such as MYH-associated polyposis occur in about one in 18000 individuals with colorectal cancer. Hereditary cases of colorectal cancer (Table. 1.1) account for nearly 6% of all colon cancer cases and this includes 3% with HNPCC, 2% with FAP and 1% with all other hereditary colon cancers including Peutz-Jeghers syndrome, familial juvenile polyposis and hereditary mixed polyposis syndrome. These syndromes are linked to mutations in LKB 1, STK11, SMAD 4, PTEN, E-cadherin, cyclin D1 and TGF- β receptors [59].

Colitis associated cancer (CAC), a subtype of colorectal cancer is associated with inflammatory bowel disease (IBD) and has high morbidity and mortality. More than 20% of inflammatory bowel disease patients develop colitis associated cancer within 30 years of disease onset and more than 50% of these patients will die from colitis associated cancer [60, 61]. Even though immune mediated mechanisms are responsible for colitis associated cancer; there are similarities between colitis associated cancer and other types of colorectal cancers that develop without any inflammatory signs. The important stages of colon cancer development such as formation of aberrant crypt foci, polyps, adenomas and carcinomas are similar between colorectal cancer and colitis associated cancer, even though different pathogenic sequences have been proposed for colitis associated cancer, such as chronic inflammation and injury-dysplasia carcinoma.

The Adenoma- Carcinoma sequence. The development of CRC via adenoma-carcinoma sequence (Fig. 1.5) is a multistep process which slowly occurs over a period of several years and often decades. Benign tumors of the gastrointestinal tract are lesions that form above the surrounding mucosa and are generally known as polyps. Colorectal polyps, particularly polyps less than 5 mm in size are hyperplastic and these polyps are not CRC precursors, where as adenomatous polyps or adenomas are considered as important precursor lesions that can progress to CRC [62]. Adenomas are characterized by dysplastic morphology and abnormal differentiation of epithelial cells that arise from glandular epithelium. The frequency of occurrence of adenomatous polyps in the US is approximately 25% in individuals 50 years of age and 50% at the age of 70 and there is a high risk for developing CRC in patients whose adenomatous polyps are not removed [63, 64]. Individuals with diseases such as FAP are strongly predisposed for development of adenomatous polyps, present with CRC at 30-50 years of age [65]. Only a small fraction of adenomas slowly (years to decades) progress to CRC, for example adenomatous polyps with 1 cm size have an approximately 10-15% chance of progression to carcinoma within 10 years period.

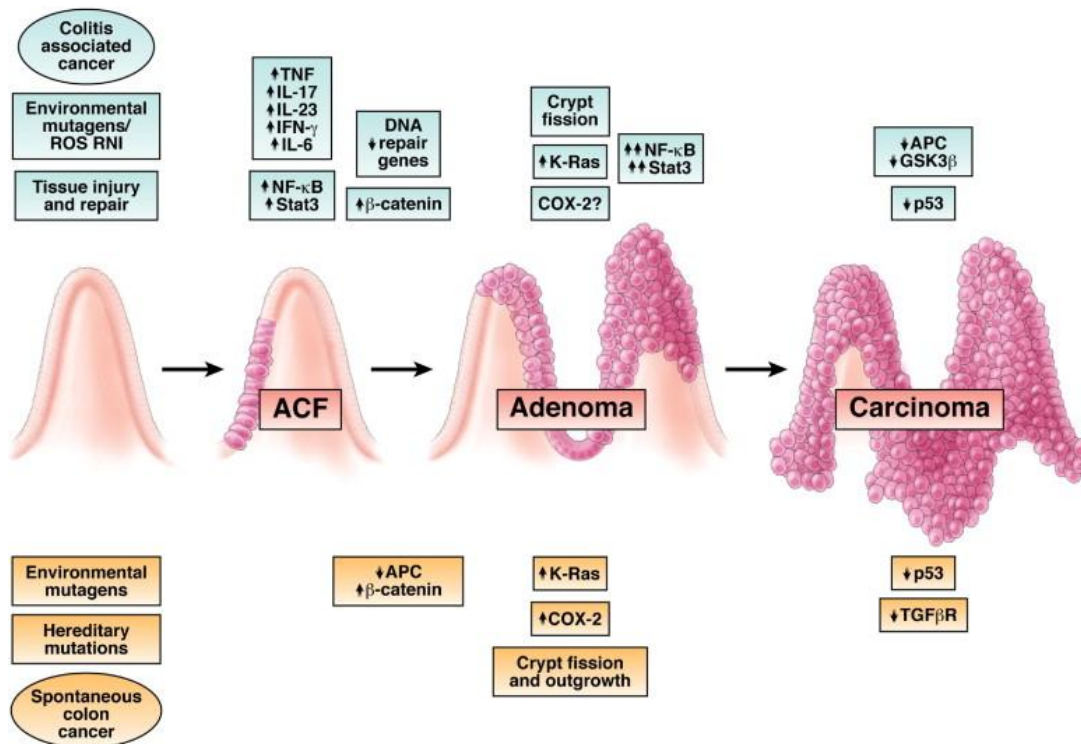

Fig. 1.5. Development of CRC and CAC; adenoma-carcinoma sequence [66].

Some of the essential stages of colon cancer development such as formation of aberrant crypt foci, polyps, adenomas and carcinomas are similar between non-inflammatory colorectal cancer and colitis associated cancer. Common genetic and signaling pathways altered in colorectal cancer and colitis associated cancer include Wnt, β -catenin, K-Ras, p53, transforming growth factor- β (TGF- β), and the DNA mismatch repair proteins (MMR).

The APC gene in colorectal cancer. FAP is an autosomal dominant syndrome that affects nearly 1 in 12000 individuals and accounts for approximately 0.5% of all colorectal cancers. Adenomas arise in the colon of affected individuals by 40 years of age, but only a few adenomas progress to colorectal cancer in a given FAP patient [65, 67]. The incidence of colorectal cancer in an untreated FAP patient is 100% by the age

of 36 years, while prophylactic treatment provides good clinical management for FAP. One fourth of FAP cases are due to germline mutations and do not show autosomal pattern and inheritance [68]. A fraction of germline mutations in FAP patients results in silencing of APC gene expression, whereas 95% of the mutations are due to frameshift or nonsense mutations that lead to premature truncation of protein synthesis (Fig. 1.6) [68, 69].

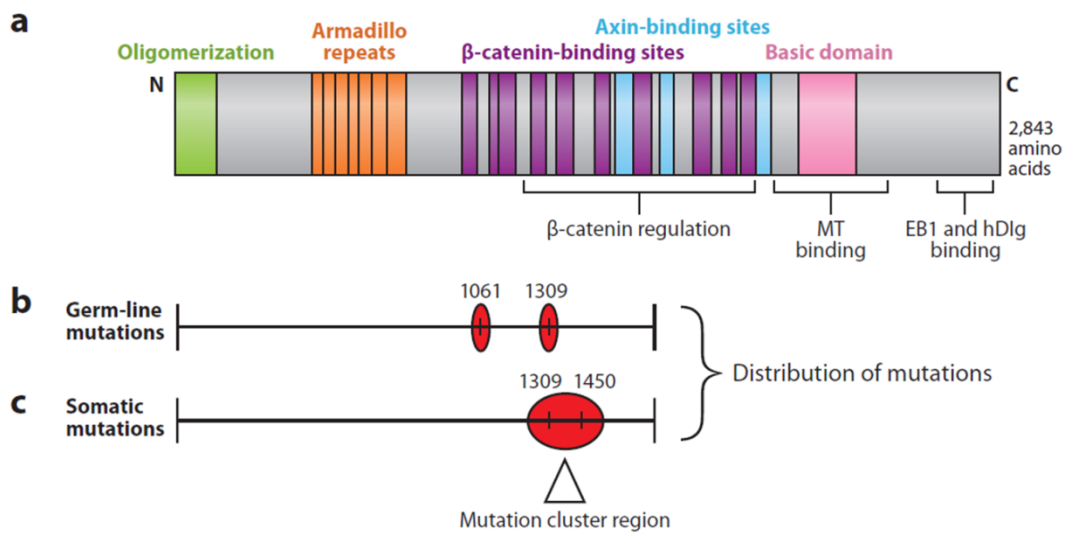

Fig. 1.6. Schematic representation of APC and mutations in APC [58].

The APC gene plays an important role in FAP and other syndromes, and also in sporadic colorectal cancer. Nearly 70-80% of sporadic colorectal cancers have somatic mutations that inactivate APC. Most somatic mutations lead to premature truncation of the APC protein and this is an early and rate limiting event in the development of adenomas [70, 71]. Frequencies of APC mutations in very small adenomas as well as advanced adenomas and carcinomas are similar, in contrast to mutations of other

somatic genes in colorectal tumors. Somatic mutations of APC are found even in earliest lesions such as microscopic adenomas which are comprised of few dysplastic glands [19]. According to the Knudson model for tumor suppressor genes, defects of both alleles in tumor suppressor genes (TSG) are required to promote tumor development. Both alleles of the APC appear to be inactivated in adenomas and carcinomas observed in FAP patients as well as patients with colorectal adenomas and carcinomas.

APC protein functions in canonical Wnt signalling pathway. The APC tumor suppressor gene encodes an approximately 300-kDa protein that regulates cell migration, cell-cell interaction, chromosomal segregation and apoptosis in the colonic crypts [72]. Restoration of APC protein function in colorectal tumors that lack endogenous APC protein expression induces apoptosis [72]. The APC protein has some recognizable sequence motifs in the primary aminoacid sequence and these serve as binding sites for various cellular proteins (Fig. 1.6). Even though the APC protein has several important cellular functions, the most well established role for APC in formation of tumors is its interaction with β -catenin and subsequent regulation of Wnt signaling pathways [70, 72].

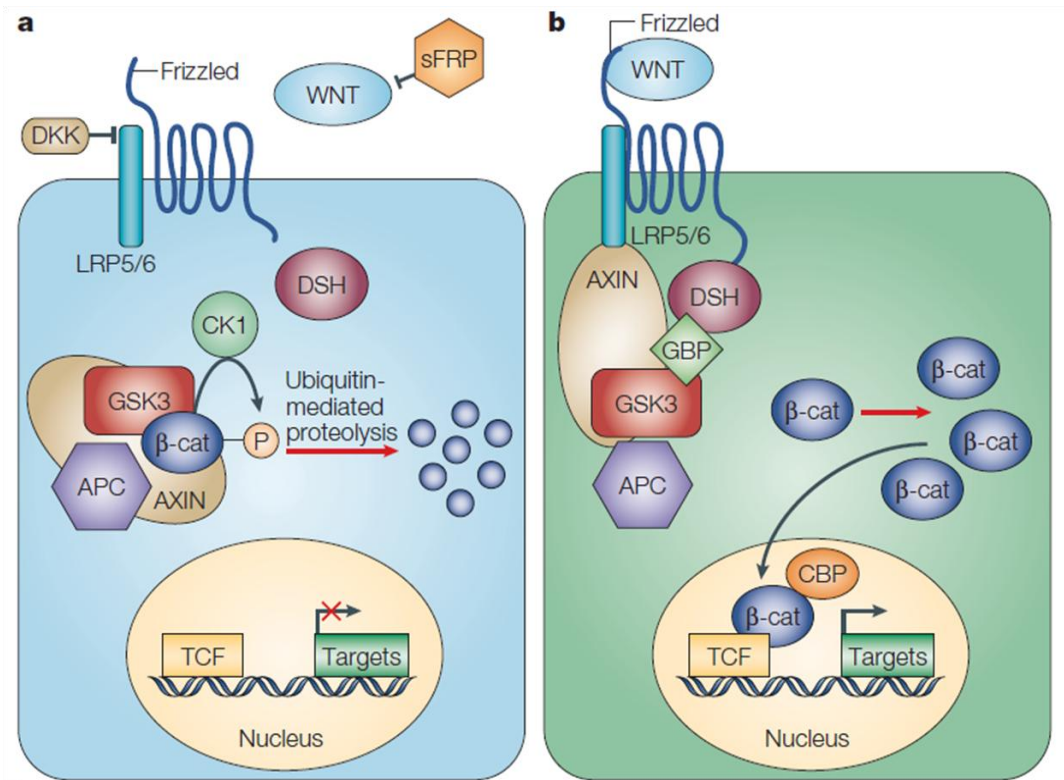

Fig. 1.7. Model of APC and β -catenin in Wnt canonical signaling. (a). absence of Wnt ligands, (b). presence of Wnt ligands [73].

β -Catenin plays an important role in linking cytoplasmic domains of E-cadherin to the actin cytoskeleton via binding to the adaptor protein α -catenin. The major components of Wnt/ β -catenin pathway is the β -catenin destruction complex which is composed of APC, AXIN, casein kinase 1 (CK 1), and glycogen synthase kinase 3 β (GSK 3 β). The proposed model for the biologic significance and interaction of APC and β -catenin shows that, in the absence of Wnt ligands, β -catenin is recruited into a destruction complex, which facilitates phosphorylation of β -catenin on conserved N-terminal serine/threonine residues by CK1 and GSK3 β (Fig. 1.7). This leads to the ubiquitylation and proteasome-dependent degradation of β -catenin. In the nucleus,

prospective target genes of the Wnt signaling pathway are kept in a repressed state by interacting with T-cell factor (TCF) and lymphoid enhancer-binding protein (LEF) transcription factors with associated co-repressors. In the 'off state', cells maintain low cytoplasmic and nuclear levels of β -catenin; β -catenin is associated with cadherins at the plasma membrane, an association that spares it from the degradative pathway. In the presence of Wnt, ligands interact with members of the Frizzled (FZ) family of serpentine receptors, and transmembrane protein low density lipoprotein receptor related proteins 5 and 6 (LRP5 and LRP6). The binding of Wnt to Fz receptors lead to activation and membrane recruitment of the phosphoprotein Dishevelled (DSH or DVL) and AXIN and the destruction complex to the plasma membrane, where AXIN directly binds to the cytoplasmic tail of LRP5/6. AXIN is then degraded, and this decreases β -catenin degradation. The activation of DSH also leads to the inhibition of GSK3, which further decreases the phosphorylation and degradation of β -catenin. So, the 'on state' involves increasing post-translational stability of β -catenin, through Wnt-dependent degradation of AXIN and inhibition of GSK3. As β -catenin levels rise, it accumulates in the nucleus, and interacts with DNA bound TCF and LEF family members to activate transcription of target genes including c-Myc and Cyclin D1 (Fig. 1.7).

In most colorectal cancers, both APC alleles are mutated and as a result coordinated phosphorylation and degradation of β -catenin is inhibited and this process mimics constitutive activation of Wnt ligand-mediated signaling and results in expression of several protooncogenes including c-Myc, Cyclin D1. In addition, the β -catenin/TCF/LEF complex activates transcription of genes encoding membrane proteins such as matrix metalloproteinase 7 (MMP7), membrane type 1 MMP (MT1MMP), laminin 5, CD44 growth factors such as fibroblast growth factor (FGF) 20, FGF 9; and

negative Wnt regulators including AXIN 2, naked-1/2, dickkopf-1, and Wnt inhibitory factor [74, 75]. Induction of the β -catenin-dependent transcription program resembles the transcriptional program in presumptive tissue stem cells at the base of colonic crypts and β -catenin not only participates in establishment of the crypt progenitor phenotype but also in the spatial organization and migratory patterns of the cells in the continuous renewal of colonic crypts [76, 77].

Wnt/ β -catenin/ TCF regulated genes are negatively regulated by feedback inhibitors such as Wnt inhibitory factor 1, dickkopf-1 and downstream Wnt ligand receptor signaling is inhibited by the homolog of the drosophila gene Naked as well as AXIN 2 gene product. Dysregulation of Wnt/ β -catenin signaling has been reported in several tumor types including colon tumors and overexpression of Wnt ligands are observed in both sporadic and familial colorectal cancer. APC gene mutations that encode a truncated protein result in a defective β -catenin destruction box, which is unable to bind to β -catenin and this results in decreased degradation of β -catenin and accumulation of high levels in the nucleus which activate Wnt target genes. Mutations in the β -catenin gene at various phosphorylation sites also prevent destruction of β -catenin by the proteasome pathway resulting in increased activation of Wnt signaling.

DNA mismatch repair gene defects in colorectal cancer. *Hereditary Nonpolyposis Colorectal cancer (HNPCC)*- HNPCC was one of the first inherited cancer syndromes to be reported in the medical literature [78]. Many years later Lynch & co-workers [79, 80] proposed autosomal dominant patterns of colorectal cancer that were not accompanied by extensive polyposis. HNPCC accounts for approximately 5% of hereditary colorectal cancer causes and this genetic syndrome is caused by mutations in the family of mismatch repair genes (MMR) which include MLH 1, MSH 2, MSH 6, and PMS 2 [81,

82]. Germline mutations in one of these four MMR genes have been observed in 80% of affected families, with 50% of the mutations in MLH1, 40% in MSH2 and 10% in MSH6. The major role of MMR genes is to maintain genomic integrity, and mutations of these genes can lead to development of colorectal cancer and other solid tumors. MMR genes also function to mediate DNA damage-induced cell death; and colorectal cancer tumors with mutated MMR genes are resistant to a wide variety of cytotoxic agents such as cisplatin, carboplatin and several alkylating agents [83, 84]. Consequently colorectal cancer tumors expressing mutant MMR genes have a selective growth advantage when compared to other solid tumors expressing wild-type with intact MMR genes. Though FAP patients develop thousands of adenomatous polyps, there are other types of intestinal polyposis syndromes in which patients' exhibit several non-adenomatous polyps that increase the risk for colorectal cancer and these include juvenile polyposis syndrome (JPS), Cowden syndrome, Peutz-Jeghers syndrome and hereditary mixed polyposis syndromes.

Oncogenic/ Tumor suppressor gene mutations in colorectal cancer. In contrast to hereditary colorectal cancer, which constitutes approximately 2-15% of all cases of colorectal cancer, sporadic cancer accounts for approximately 80-85% of colorectal cancer. The genetic alterations leading to dysregulation of key signaling pathways in hereditary colorectal cancer have also been implicated in the pathogenesis of sporadic colorectal cancer. The key pathways that are affected include Wnt/ β -catenin, TGF- β receptor, Notch, Hedgehog, EGFR, Ras/Raf/MAPK and phosphoinositide 3-kinase PI3/Akt pathway.

TGF- β / SMAD. The TGF- β plays an important role in several biological processes such as cell proliferation, differentiation, migration and apoptosis [85, 86]. TGF- β ligands bind

to type II TGF- β receptors (TGFB2) resulting in recruitment and activation of downstream factors include TGFB1, SMAD 2, SMAD3, SMAD4 and heterodimeric SMAD complexes that translocate into the nucleus. SMAD complexes bind and activate or deactivate several different transcription factors including c-Jun, P300/CBP, c-Myc and cyclin associated protein CD1, cyclin dependent kinase inhibitors cdk 4, p21, p27, p15 and Rb in a cell specific manner. TGF- β acts as a tumor suppressor and inhibits growth by activation of cyclin-dependent kinase inhibitors p21, p27, p15; however TGF- β also activates oncogenes such as TGF- α , FGF, EGFR and SMAD-independent pathways such as Ras/Raf/MAPK, JNK and PI3/Akt. In addition, TGF- β also promotes angiogenesis, cell adhesion and motility enhancing tumor invasion and mutagenesis.

The gene encoding TGFB2 has A nucleotide repeats in exon 3, and GT repeats in exons 5 and 7, and these repeats are prone to DNA replication errors and frameshift mutations. Approximately 80% of colorectal cancers and 30% of sporadic colorectal cancers have frameshift mutations in TGFB2 and to date this is the most common pathway leading to alterations in TGF- β signaling [87]. Mutations of SMAD genes can also impair TGF- β signaling. Interestingly, SMAD2 and SMAD4 are localized on chromosome 18q, a region that is usually deleted in colorectal cancer and mutations of SMAD2 and 4 are observed in 10-25% of colorectal cancers. There is growing evidence that alterations of TGF- β signaling lead to development of colorectal cancer and this is an attractive target for cancer drug development.

Notch signaling pathway. Notch signaling is important for proliferation of intestinal epithelium and under normal physiological conditions, Notch ligands bind to transmembrane receptors resulting in cleavage and the release of the intracellular domain of the Notch receptor. The cleaved Notch receptor translocates to the nucleus

and activates Notch target genes such as hairy/enhancer of split (Hes 1) a basic helix-loop-helix transcription factor. Notch signaling is important for several physiological functions such as maintenance of stem cells, determination of cell fate, differentiation and oncogenesis. Notch signaling is constitutively activated in several cancers and there is increased expression of Notch ligand in colorectal cancers [88]. Moreover, crosstalk between Notch and Ras, where active Ras mutants activate Notch signaling and Notch activation is required for Ras-mediated cell transformation.

Hedgehog Signaling Pathway. The hedgehog signaling plays an important role in proliferation, establishment of cell fates and embryonic development in *Drosophila* [89, 90]. This pathway has also been identified in humans and is essential for development and patterning of various organs including gut epithelium. Hedgehog ligands bind to receptors of Patched Protein (Ptch) which suppress activity of smoothed receptor (Smoh), a G Protein-coupled receptor-like receptor. Hedgehog ligands bind to Ptch1 and activate GL1 transcription factor and regulate expression of several Hedgehog target genes. Aberrant activation of Hedgehog signaling is associated with enhanced cell proliferation and development of cancer [89]. Moreover Hedgehog signaling is involved in development and repair of colonic epithelial cells and this pathway is activated in colorectal cancer [91].

Several studies have reported high expression of Hedgehog ligands, Hedgehog receptor ptch, and Hedgehog associated transmembrane receptor Smoh in hyperplastic polyps, adenomas and adenocarcinomas of colon [92, 93]. The exogenous Hedgehog ligand Snh, can promote the growth of colonocytes and colorectal cancer cells express high levels of Snh mRNA compared to normal colon cells [94].

Ras signaling pathway. Ras is a member of a small G protein family which are critical for transmitting extra-cellular signals such as epidermal growth factors (EGFs) into intracellular signal transduction cascades [95]. Ras proteins have intrinsic GTPase activity and GDP/GTP-binding sites that are responsible for active (GTP-bound) and inactive (GDP-bound) confirmation. Ras proteins activate Raf/MEK/ERK signaling that mediate cell growth and cell cycle progression through phosphorylation of important transcription factors such as c-fos, Myc, RSK and MNK, and activation of the PI3K/Akt pathway. The role of Ras has been extensively investigated in cancer and approximately 15-20% of all human cancers exhibit Ras gene mutations. To date the 3 Ras genes encode for 4 Ras proteins; namely, H-Ras, N-Ras, K-Ras4A, and K-Ras4B. Each of these Ras proteins is activated in different types of human cancers; K-Ras mutations are typically observed in CRC, pancreatic cancer, lung cancer and seminoma. In CRC, 30-40% of all patients have K-Ras gene mutation and >95% these mutations are observed in codons 12, 13 and 61. These mutations result in constitutively bound GTP in the active form of Ras which is independent of extracellular signals such as EGF. As a result K-Ras mutated tumors are resistant to anti-EGFR therapy with cetuximab or panitumumab which are antibodies that bind the EGFR with high affinity [96].

EGFR signaling pathway. The EGFR belongs to human epidermal growth factor receptor (HER) family that includes HER1 (ErbB1, EGFR), HER2 (ErbB2), HER3 (ErbB3) and HER4 (ErbB4) [97]. Upon ligand binding, EGFR undergoes homo or heterodimerization with other members of HER family and regulates cell proliferation, survival, migration, invasion and angiogenesis through activation of several signaling networks [98]. Activation of EGFR is primarily responsible for development of resistance

to chemo and radiation therapies. EGFR is progressively upregulated from normal to malignant tissues and nearly 90% of metastatic CRC overexpresses the EGFR [99]. The role of EGFR in growth, proliferation and metastasis is well documented in several cancers and this receptor is an important target for drug development [100, 101]. Anti-EGFR monoclonal antibodies such as, Cetuximab and Panitumumab are currently used for treatment of metastatic CRC; these drugs bind the EGFR with higher affinity than the natural ligands and inhibit phosphorylation and downstream signaling pathways and receptor internalization resulting in decreased cell surface expression of EGFR [102]. These drugs inhibit tumor angiogenesis and cell proliferation, induce apoptosis and cell cycle arrest.

PI3K/Akt signaling pathways. PI3K signaling cascades play an important role in regulation of several key cellular processes including protein synthesis, glucose metabolism, cell proliferation, migration and angiogenesis [103]. PI3K is composed of a 110-kDa catalytic subunit (PKC3A) and an 85-kDa adapter subunit. PI3K signaling is regulated by crosstalk with other extracellular signaling pathways activated by hormones, vitamins, integrins, intracellular calcium and Ras dependent MAPK. PI3K is constitutively activated in several cancers, such as CRC, breast cancer, prostate cancer and lung cancer [104]. Constitutive activation of PI3K is due to a mutation in PIK3CA resulting in a gain of function mutation affecting positive regulators of PI3K (HER2, EGFR, RAS and c-Src). Activation of PI3K function can also be due to mutations of tumor suppressor genes encoding negative regulators of PI3K such as PTEN. Activation of PI3K/Akt has been observed in several cancers including CRC, gastric cancer, breast cancer and ovarian cancer [105]. Moreover activation of various components of PI3K/Akt signaling has prognostic significance for several cancers and

PI3K activation contributes to resistance to chemotherapy, hormone and radiation therapy and several individual components of this signaling pathway are therapeutic targets for drug development [106].

EPIGENETIC CHANGES IN COLON CANCER

Epigenetics broadly refers to the heritable changes in gene expression that are not mediated by the changes in the DNA sequence. Epigenetic regulation of gene expression is important for embryonic development and tissue differentiation [107]. Aberrant epigenetic alterations were first discovered in CRC in 1982, and subsequent studies have revealed a complex array of epigenetic regulatory mechanisms that control gene expression in both normal and cancerous tissue [108, 109]. Epigenetic regulation of gene expression is determined by several factors, such as open and closed state of chromatin that leads to either gene transcription and silencing of gene transcription respectively [107].

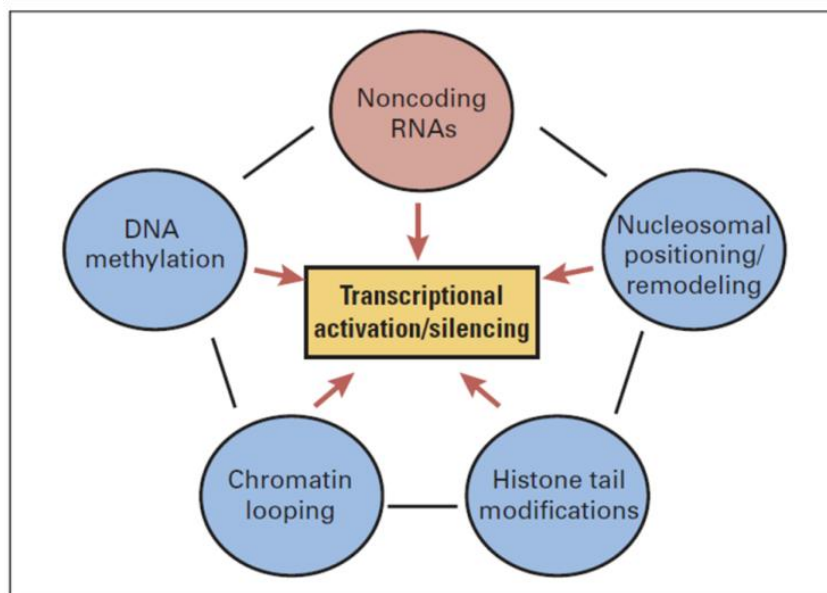

Fig. 1.8. Epigenetic mechanisms in colorectal cancer [110].

The epigenetic mechanisms responsible for colon cancer development include methylation of CpG islands, post translational histone modifications, micro RNAs and non-coding RNAs and nucleosome positioning (Fig. 1.8).

Methylation of CpG islands. Promoters of approximately 50% of all genes contain CpG islands and hypermethylation of these CpG islands is responsible for transcriptional silencing of gene expression [111, 112]. Decreased DNA methylation has been observed in CRC cells (compared to normal cells). Even though hypomethylation is commonly observed in CRC [113, 114], hypermethylation of CpG islands at specific gene promoters has been observed [115, 116].

DNA hypomethylation was one of the first recognized epigenetic alterations in CRC, and its occurrence is age-dependent and is observed early in the process of carcinogenesis [117]. Hypomethylation in CRC was assumed to be associated with activation of oncogenes such as CDH3, which is responsible for increased genomic instability. Experimental relevance of hypomethylation to genomic instability is supported by mouse models where DNMT hypomorphic *Apc*^{MIN/+} mice develop microadenomas associated with loss of heterozygosity of APC and increased genomic instability. DNA hypermethylation has been extensively characterized in CRC and is observed in nearly 60% of genes [118]. Hypermethylation of promoter CpG islands has been observed in several tumor suppressor- and DNA repair genes and leads to their inactivation or lack of function [112]. Hypermethylated genes include HIC1 (hypermethylated in cancer 1) and Wnt signaling antagonists such as SFRPs (secreted Frizzled-related proteins), RTK, TP53, PI3K, retinoic acid and IGF signaling pathways and other pathways regulating the cell cycle, transcription, DNA repair, stability, apoptosis, angiogenesis, invasion, metastasis and chromatin organization (Table. 1.2)

[115, 119]. Hypermethylated DNA is silenced through recruitment of methyl CpG binding proteins and associated repressors such as HDACs, which form repressive chromatin structure.

Table 1.2. Promoter CpG island hypermethylated genes in colorectal cancer [110].

Promoter CpG island hypermethylated genes in colorectal cancer	
Signaling pathways/cancer hallmarks	Promoter CpG island hypermethylated genes
Wnt	<i>APC, SFRP1, SFRP2, SFRP4, SFRP5, SOX17, WNT5a, DKK1, DKK3, WIF1, AXIN2</i>
RTK	<i>RASSF1A, RASSF2A, EPHB2, RAB32, NORE1</i>
NOTCH	<i>NEURL</i>
TP53	<i>P14ARF, HIC1, DNFBNA5</i>
PI3K	<i>PIK3CG</i>
Estrogen receptor	<i>ER</i>
Retinoid acid receptor	<i>RAR, CRABP1</i>
IGF	<i>IGFBP3, IGFBP7</i>
Cell cycle regulation	<i>P16INK4A, KLF4</i>
Transcription regulation	<i>GATA4, GATA5, RUNX3, CDX1, HLF, FOXL2, ALX4</i>
DNA repair/stability	<i>MLH1, MGMT, WRN, CHFR</i>
Apoptosis	<i>BNIP3, IRF8, DAPK1, HRK</i>
Adhesion	<i>CDH4, CDH13</i>
Angiogenesis	<i>THBS1</i>
Invasion and metastasis	<i>TIMP3, RECK, CXCL12, TFPI2</i>
Axon guidance	<i>SLIT2</i>
Transmembrane (glyco)proteins	<i>MUC1, NMDAR2A, HPP1, SPARC, DCC, CD133</i>
Peptide hormones	<i>SST, TAC1</i>
Chromatin organization	<i>PRDM2</i>
Unknown function/pathway	<i>VIM, NDRG4</i>
Classical CIMP panel	<i>MINT1, MINT2, MINT31, P16INK4A, MLH1</i>
Weisenberger CIMP panel	<i>CACNA1G, IGF2, NEUROG1, RUNX3, SOCS1</i>
NOTE: This table represents genes involved in major signaling pathways/cancer hallmarks that are epigenetically silenced by promoter CpG island hypermethylation. Abbreviations: WNT, wingless-type; MMTV integration site family; RTK, receptor tyrosine kinase; NOTCH, neurogenic locus notch homolog protein; TP53, tumor protein 53; IGF, insulin-like growth factor; CIMP, CpG island methylator phenotype.	

To date three types of CpG binding proteins have been identified: methyl binding domain (MBD) family of proteins containing MBD1, MBD2 and MBD4, the zinc finger proteins Kaiso (ZBTB33), ZBTB4 and ZBTB38, and SET and RING finger associated proteins UHRF1 and UHRF2. Loss of MBD2 and Kaiso in APC^{min/+} mice suppresses intestinal carcinogenesis and induces tumor suppressor gene expression resulting in cell cycle arrest and cell death [120, 121].

Post translational histone modifications. Post translational histone modifications regulate gene expression at the transcriptional level and these modifications dictate chromatin structure by disrupting contacts within or between nucleosomes. The most well-characterized histone modifications in CRC are histone deacetylation and histone demethylation. Active genes are enriched with di- and trimethylation of histone H3 lysine 4 (H3K4me2/me3) and acetylation of key H3 and H4 aminoacids at the transcription startsite, while inactive genes lack these active modifications and are characterized by trimethylation of histone H3 lysines 9 and 27 (H3K9me3 and H3K27me3). Many genes hypermethylated in CRC include components of polycomb repressor complexes (PRC) such as EZH2 and CBX7 respectively and PRC-dependent DNA methyltransferases play a role in DNA methylation [122, 123].

Small, non-coding RNAs. Another important mechanism of epigenetic regulation involves the role of small non coding microRNAs (miRNAs) which are generated from precursor pre and pri-RNAs by successive cleavage by drosha and dicer nucleases. Depending on the degree of homology to their target sequence, miRNAs bind 3'-UTRs of target mRNAs via base pairing and inhibit translation or induce mRNA degradation. Comprehensive analysis of miRNA expression in human cancers reveals differential miRNA expression in cancers [124]. Comparisons between CRCs, such as MSS CRC

and MSI-H CRC show differences in the abundance of specific miRNAs, for example miR-25 and miR-92 are highly expressed in MSS rather than MSI-H colon cancers (Fig. 1.9) [125].

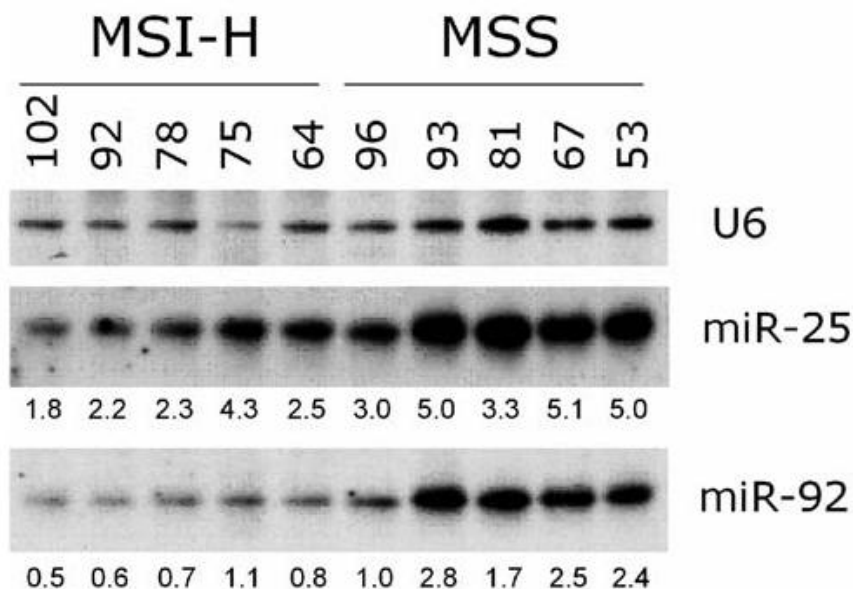

Fig. 1.9. Northern blot analysis of miRNAs miR-25 and miR-92. Northern blot analysis confirmed that these miRNAs were up-regulated in MSS samples. miRNA/U6 ratio of densitometric intensities is shown below each miRNA lane [125].

Although many of the differences in miRNA expression in CRCs may be related to differential expression of the primary transcripts that contain the miRNAs, as indicated above, p53 mutations can affect processing of certain miRNAs. For example, tumor suppressor, p53, enhances the post-transcriptional maturation of several miRNAs with growth-suppressive function, including miR-16-1, miR-143 and miR-145, in response to DNA damage. In HCT116 colon cancer cells and human diploid fibroblasts, p53 interacts with the Drosha processing complex through the association with DEAD-box RNA helicase p68 (also known as DDX5) and enhances processing of primary

miRNAs to precursor miRNAs. In contrast, transcriptionally inactive p53 mutants interfere with the functional assembly between the Drosha complex and p68, resulting in attenuation of miRNA processing [126]. In addition, oncogene and tumor suppressor gene signaling pathways that are normally dysregulated in CRC may also influence the expression of several miRNAs resulting in modulation of expression of different genes and proteins [127]. miRNAs are involved in different stages of colon carcinogenesis such as epithelial cell differentiation (miRNA-141, miRNA-200c), Wnt signaling (miRNA-145, miRNA-135a and miRNA-135b), migration and invasion (miRNA-373, miRNA-520c) [128-130]. miRNA-124a is involved in cell cycle regulation and is associated with CpG island hypermethylation, closed state of chromatin and occupancy of MeCp2 and MBD2. miRNA-34b and miRNA-34c that target TP53 pathways, undergo frequent promoter CpG island methylation in CRC. Certain metastatic CRCs are associated with promoter CpG methylation of miRNA-148a, miRNA-34b, miRNA-34c, and miRNA-9 [131-133].

INFLAMMATION AND COLORECTAL CANCER

CAC is a type of CRC that is associated with IBD, which exhibits high mortality and more than 20% of IBD patients develop CAC within 30 years of disease onset and approximately 50% of these patients will die from CAC [61, 134]. Even though IBD and CAC are associated with immune mediated mechanisms, there are some similarities between CAC and other types of CRC that develop without any signs of inflammation. The important stages of colon cancer development such as formation of aberrant crypt cocci, polyps, adenoma and carcinomas are similar in between CRC and CAC, even though different pathogenic mechanisms including chronic inflammation and injury-dysplasia carcinoma have been proposed for CAC. Moreover common genetic and

signaling pathways, such as Wnt, β -catenin, K-Ras, p53, TGF- β , and DNA mismatch repair genes are altered in both sporadic CRC and CAC, even though the timing of p53 and APC inactivation and K-Ras activation differs in CRC and CAC [61, 135]. Finally, colorectal tumors that are not associated with IBD show infiltration of inflammatory cytokines and IBD patients with familial history for CRC, exhibit a higher risk for colon cancer development, suggesting overlapping mechanisms for development of CAC and CRC [136-140]. Moreover, a large number of CRC tumors exhibit constitutive activation of transcription factors that play an important role in inflammatory pathways and these include, NF- κ B and STAT3 (signal transducer and activator of transcription 3) [141, 142]. Therefore it is possible that inflammatory cytokines and immune mechanisms act through similar but also distinct pathways in the pathogenesis of CRC and CAC.

Inflammation in initiation of CRC and CAC. For CRC, intratumoral immune cells are recruited after the tumor is formed therefore chronic inflammation does not precede tumor formation. Once the tumor is formed, localized inflammatory mediators promote additional mutations & epigenetic alterations and inflammatory cells produce reactive oxygen and nitrogen species that also induce mutations and DNA damage [143, 144]. Moreover immune mediated ROS production can diffuse into adjacent epithelial cells and cause mutations and epigenetic silencing of tumor suppressor genes. However, the contributions of immune-mediated mechanisms in cancer initiation is unclear [145]. In CAC, chronic inflammation precedes tumor development and the associated inflammation results in oxidative damage to DNA and p53 mutations with nondysplastic epithelium [146, 147]. In mouse models, inflammatory mediators such as dextran sodium sulfate (DSS) induce DNA damage and colonic adenomas; the number of

adenomas is increased and appeared much earlier if the procarcinogen azoxymethane (AOM) was administered to mice before DSS [148].

Table. 1.3. Incidence of large bowel neoplasms in mice treated with AOM and various doses of DSS [149].

Group No	TREATMENT (no. of mice)	INCIDENCE (MULTIPLICITY) OF LARGE BOWEL NEOPLASMS		
		Total	Adenoma	Adenocarcinoma
1	AOM@2%DSS (4)	100%* (4.00±3.37)	75%** (1.25±1.26)	100%* (2.75±2.22)
2	AOM@1%DSS (5)	100%*** (2.40±2.19)	80%** (1.00±0.71)	60% (1.40±2.07)
3	AOM@0.5%DSS (5)	20% (0.20±0.45)	20% (0.20±0.45)	0%
4	AOM@0.25%DSS(5)	0%	0%	0%
5	AOM@0.1%DSS (4)	0%	0%	0%
6	AOM (5)	0%	0%	0%
7	2%DSS (5)	0%	0%	0%
8	None (5)	0%	0%	0%

In mice receiving AOM plus 2% DSS, the incidence (multiplicity) of colonic tubular adenoma and adenocarcinoma was 75% (1.25 ± 1.26 /mouse) and 100% (2.75 ± 2.22 /mouse), respectively. Mice administered AOM plus 1% DSS had an 80% incidence of adenoma (1.00 ± 0.71 /mouse) and 60% incidence of adenocarcinoma (1.40 ± 2.07 /mouse) in the colon. In mice treated with AOM and 0.5% DSS, only one colonic adenoma (20% incidence with 0.20 ± 0.45 multiplicity) developed. A higher frequency of high-grade colonic dysplasia was noted in mice given AOM and 2% or 1% DSS when compared to mice treated with AOM and lower doses of DSS. Also, scoring for inflammation and nitrotyrosine immunoreactivity suggested that severe inflammation and nitrosation stress caused by high-doses (2% and 1%) of DSS enhanced AOM

initiated tumor formation (Table. 1.3). These findings indicate that the tumor-promoting activity of DSS was dose-dependent (1% or more) and the effects occurred under conditions of inflammation and nitrosation stress. In addition, inflammation induced mutations also inactivate MMR genes and activity of these mismatch repair enzymes is inhibited by ROS through oxidation [145, 150]. Epigenetic silencing facilitates development of CAC and CRC through reduced expression of proteins that maintain DNA stability during replication or act as tumor suppressors [65, 150-155]. Expression of several genes responsible for colon cancer development such as TGFBR2, TCF4, MSH1 & 2, APC, K-Ras, SMAD4, and PTEN is regulated by miRNAs and DNA methyl transferases [151]. The activity and expression of DNA methyl transferases such as Dnmt1 and Dnmt3 are induced during inflammation and are responsible for gene silencing in mouse and human colon cancers [156]. Inactivation of DNA methyl transferases in mouse CRC results in decreased tumor progression as well as inhibition of tumor formation [157]. Moreover inflammatory mediators can induce epigenetic changes that are responsible for cell transformation.

Inflammation in promotion of CRC and CAC. Even though both sporadic CRC and CAC arise from dysplastic precursor lesions, the nature and timing of the dysplasia are sufficiently different to classify CRC and CAC as unique entities (Fig.1.10). In IBD, the premalignant lesion is not referred to as an adenomatous polyp, as is characteristic in sporadic CRC, because the histology of the lesion in IBD is usually not polypoid. Usually, colorectal cancer developed in the setting of IBD does not progress along the same adenomatous polyp to an invasive cancer pathway, but rather arises from flat dysplastic tissue [158]. Nearly, 80 to 85% of sporadic CRC involves chromosomal instability and loss of heterozygosity, which contributes to the loss of function of several

tumor suppressor genes including APC and p53. Loss of APC function is an early initiating factor in development of the adenoma, whereas the loss of p53 gene function occurs later and is the defining event that converts the adenoma to carcinoma. The remaining 15% of colorectal cancers arise through a pathway that involves microsatellite instability and microsatellite instability-positive sporadic colorectal cancers tend to occur in the proximal colon and have a better survival rate than cancers without microsatellite instability [159].

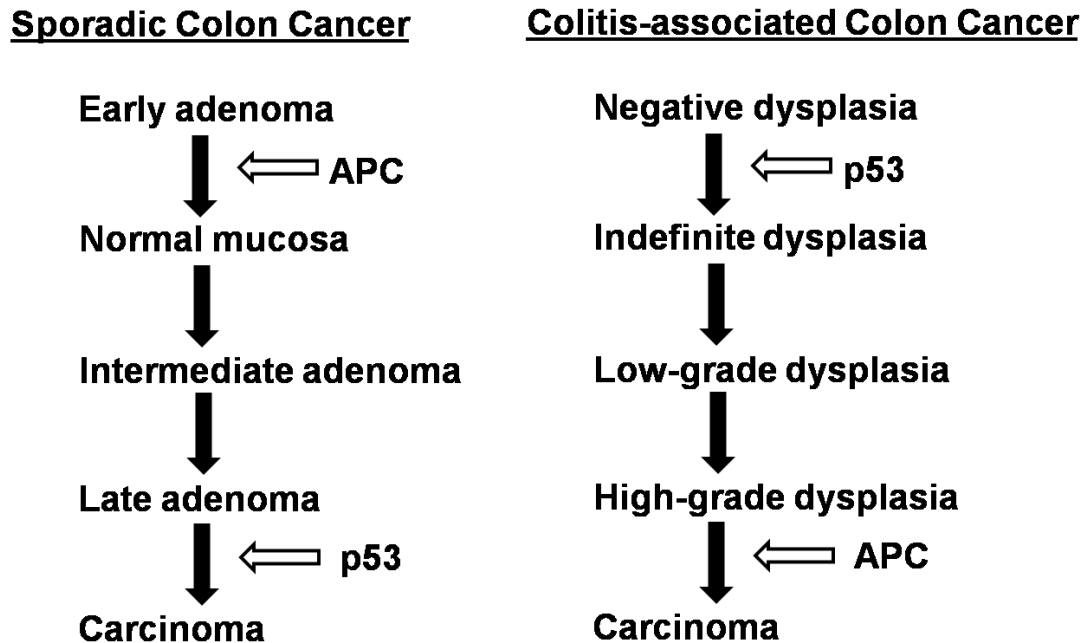

Fig. 1.10. Comparison of the carcinogenesis pathway of sporadic colorectal cancer and colitis-associated colorectal cancer [160].

The same two major pathways of chromosomal instability and microsatellite instability are involved in the pathogenesis of CAC and in both CAC and sporadic CRC, 80% of the cases involve chromosomal instability and 20% involve microsatellite

instability [161, 162]. However, the timing of the molecular changes are distinct. Loss of APC function is much less frequent in ulcerative CAC and usually occurs later than observed for sporadic CRC [163]. Loss of p53 gene function occurs early in CAC as cells progress toward dysplasia and cancer whereas in sporadic CRC, p53 is mutated late [164, 165]. Mutation of the p53 gene in both types of cancers may precede the development of aneuploidy. Further research is required to understand differences in the timing of the molecular changes in CAC compared to sporadic cases of CRC, and whether it is the chronic inflammatory changes in IBD that influence this alteration.

There are other mechanisms of carcinogenesis that distinguish between sporadic CRC and CAC. A study by Ezaki *et al.*, [166] indicated that loss of heterozygosity on chromosome 6 is specific for ulcerative CAC and is not found in either sporadic CRC or other inflammatory lesions in the colon of patients with ulcerative colitis. This indicates that there are novel tumor suppressor genes on chromosome 6 related to the development of colorectal cancers in ulcerative CAC but not in sporadic cases. There is a lower apoptotic count in tumors from patients with ulcerative CAC compared to sporadic CRC patients, implying differences in regulation of apoptosis [167]. Identifying biomarkers for earlier detection of cancer or dysplasia is extremely important, since this would enhance effectiveness of early treatment. Methylation of the HPP1 gene, a gene found in hyperplastic polyps of the colon, appears to be a relatively common early event in ulcerative colitis-associated carcinogenesis that is not found in non-neoplastic ulcerative colitis mucosa [168]. CDH1 promoter methylation may also be involved in the neoplastic progression from chronic inflammation to colorectal cancer in patients with ulcerative colitis [169]. Abnormal p53 immunohistochemistry in tumors from patients with ulcerative colitis is associated with

an increased risk of cancer-related deaths and the adjusted relative risk was 3.03 [170]. These genes may prove to be attractive new biomarkers for detecting and predicting colorectal cancer in patients with ulcerative colitis.

NF- κ B and Colon cancers. Nuclear factor- κ B (NF- κ B) belongs to NF- κ B/Rel family of transcription factors, which can dimerize through the Rel homology domain to form a variety of transcription factor complexes. The most abundant form of NF- κ B is the Rel A and p50 heterodimer which exists in the cytoplasm as a complex with I- κ B inhibitory proteins. The classical mechanism of NF- κ B activation in CAC and CRC is due to tumor promoting cytokines such as TNF- α and interleukins. These cytokines activate the I- κ B kinase (IKK), which phosphorylates and degrades I- κ B through the ubiquitination-proteasome pathway and this results in translocation of NF- κ B into nucleus to enhance transcription of target genes [171, 172]. An alternative of NF- κ B activation involves the IKK and p52/RelB transcription factor complex and cytokines such as RANKL and lymphotoxin- β in colorectal cancers. Prolonged retention of NF- κ B in the nucleus is mediated by STAT-3, which is expressed constitutively in >50% of colorectal cancers [173]. No activating mutations of NF- κ B or STAT-3 have been found in colorectal tumors suggesting that these transcription factors are activated through paracrine or autocrine pathways or activation of upstream components of their signaling pathways.

NF- κ B is a commonly expressed inducible transcription factor that regulates expression of several genes involved in inflammation, proliferation, differentiation and apoptosis [174]. These functions are responsible for normal tissue homeostasis and the activity of NF- κ B is tightly controlled in the regulation of cellular growth and apoptotic cell death [175, 176].

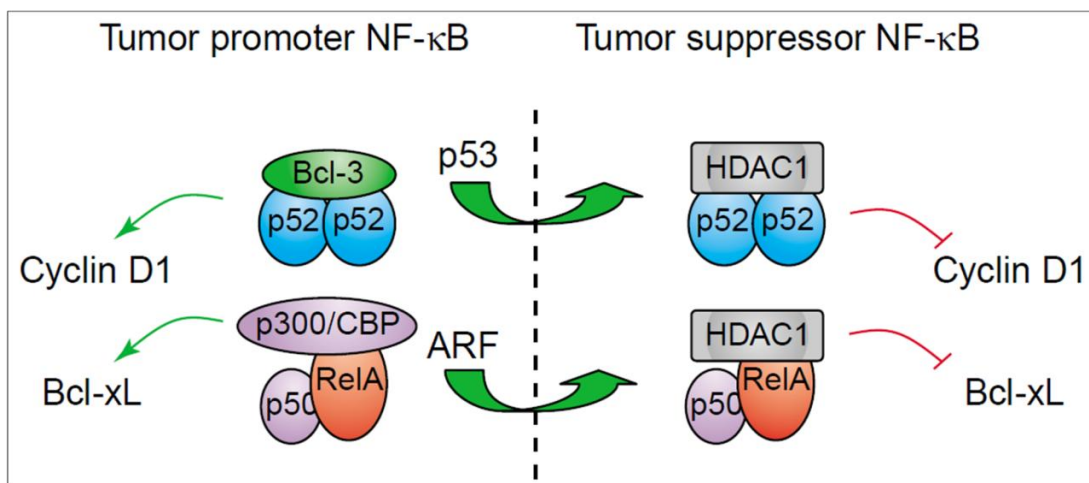

Fig. 1.11. Regulation of NF- κ B activity by tumor suppressors [175].

The cellular consequences of NF- κ B activation are complex and can result in cell context-dependent pro-apoptotic and anti-apoptotic effects [177]. NF- κ B subunits are inherently oncogenic and tumor promoting because of their ability to induce the expression of genes that promote resistance to apoptosis (e.g. Bcl-xL) and induce proliferation (e.g. cyclin D1) (Fig. 1.11). However, tumor suppressor proteins, such as p53 and ARF, can induce the association of NF- κ B subunits with histone deacetylase 1 (HDAC1) co-repressor complexes resulting in NF- κ B -dependent repression of gene expression; in this mode NF- κ B subunits facilitate apoptosis and cell-cycle arrest, and function as tumor suppressors (Fig 1.11) [175].

Moreover, TNF-induced activation of NF- κ B results in nuclear translocation of NF- κ B resulting in activation of survival and growth pathways [178]. Aberrant activation of NF- κ B pathway results in tumor formation and induces drug resistance due to increased binding NF- κ B with DNA promoters [179]. In contrast, stress inducing agents such as UV radiation and serum deprivation activate NF- κ B and induce cell death [180,

181]. Most of the tumor promoting cytokines activates NF- κ B signaling in premalignant and immune cells.

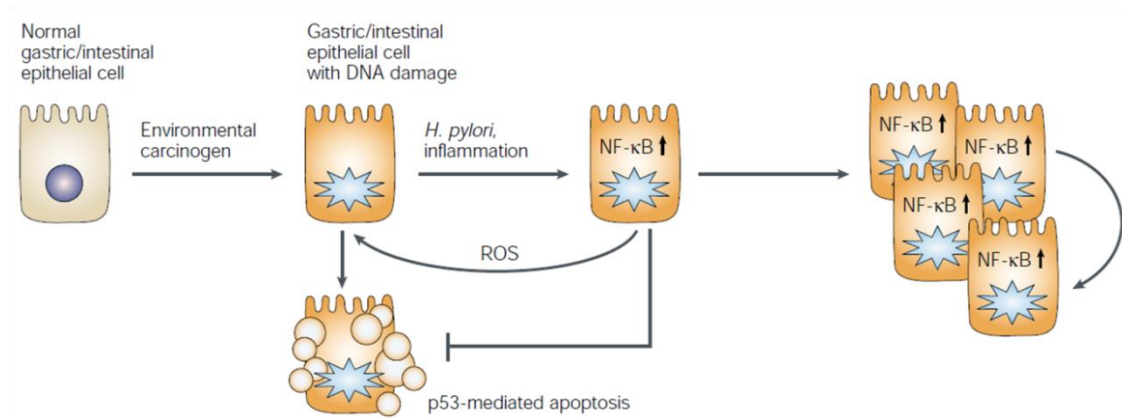

Fig. 1.12. Role of NF- κ B in gastric and colorectal cancers [176].

Aberrant activation of NF- κ B which has been observed in more than 50% of CRC and CAC and plays a prominent role in colorectal and colitis associated tumorigenesis [182, 183]. Exposure to environmental carcinogens in the diet causes DNA damage of gastric or intestinal epithelial cells and these cells are normally eliminated by p53-mediated apoptosis. However, oncogene activation or loss of tumour-suppressor activity, coupled with inflammation, can result in constitutive activation of NF- κ B, production of inducible nitric oxide synthase (iNOS) and cyclooxygenase-2 (COX-2) enzymes, which enhance production of ROS and ROS-mediated DNA damage. Growth factor and cytokine-dependent activation of NF- κ B supports colon tumorigenesis by increasing cell proliferation and angiogenesis, inhibiting cell death and promoting cell invasion and metastasis [175] [184]. NF- κ B activates several survival genes such as bcl-2, Bcl-xL and these genes play a role in radiation and drug

resistance and inactivation of NF- κ B enhances the sensitivity to these agents [185, 186].

In IBD, persistent activation of NF- κ B in myeloid & epithelial cells of the colonic mucosa is observed and inhibition of Rel A expression with antisense oligonucleotides alleviates many IBD symptoms [187, 188]. However, in DSS-induced intestinal injury-dependent acute colitis, NF- κ B is activated in intestinal epithelial cells and has a protective role [189]. Most of the drugs that are commonly used to treat acute IBD including sulfasalazine, mesalamine, glucocorticoids, and methotrexate, inhibit NF- κ B or IKK kinases [190]. Conditional ablation of IKK- β in enterocytes decreased tumor incidence by 80% without affecting tumor size, indicating that NF- κ B activation is involved in early stages of tumor promotion, rather than progression or growth [182]. Early pathogenic events in the AOM + DSS mouse model of colitis includes increased apoptosis in IKK- β deficient enterocytes and premalignant cells, which probably resulted from inactivation of Bcl-xL [191]. Increased activation of NF- κ B in epithelial cells increased tumor incidence and deletion of IKK- β in inflammatory cells (eg, DC, macrophages, neutrophils) decreased tumor size and tumor incidence by 50% [191]. Activation of NF- κ B in myeloid cells (especially lamina propria macrophages and DC) enhanced production of cytokines including TNF- α , IL-6, IL-1 β , and IL-11 that acted as growth factors for premalignant enterocytes [182]. Expression of TNF- α and IL-6, in serum samples from patients was associated with increased risk for colorectal adenoma [192].

Role of cyclooxygenases (COX) in colorectal cancers. Two isoforms of COX are known, and to date most studies have implicated COX-2, rather than COX-1, as the isoform involved in colon carcinogenesis [193]. COX-2 is an inducible mediator of

prostaglandin synthesis and the first evidence linking COX-2 to carcinogenesis emerged from studies on CRC. A significant elevation of COX-2 expression was seen in 85% and 50% of human colorectal carcinomas and adenomas respectively (Fig. 1.13) [194].

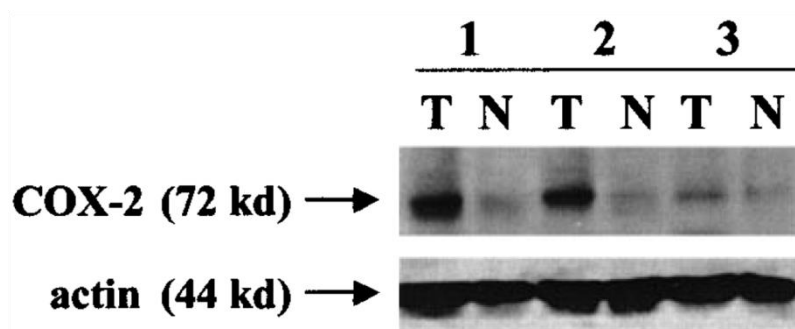

Fig. 1.13. Western blots showing COX-2 protein levels (72-kilodalton band) in paired tissues from sporadic CRCs (T) and normal mucosa (N) (left panel). Increased COX-2 expression was seen in tumors compared with normal tissue in which a low level of COX-2 was detected [195].

Immunostaining shows expression of both COX-1 and COX-2 in mucosal epithelial cells, mononuclear cells, vascular endothelial cells and smooth muscle, while in human and animal models of colorectal cancer there is dramatic increase in COX-2 expression in malignancies compared with adjacent normal mucosa. COX-1 expression appears to be unchanged or even decreased in human colonic cancers [196-198]. AOM-induced colon cancer, APC^{Min/+} mice [199] as well as in APC^{Δ716} mice (another *Apc* mutant model) exhibit increased expression of COX-2 mRNA and protein (but not COX-1) in colorectal tumors compared with normal adjacent tissue where as COX-2 knockout results in decreased tumor formation in all models [200]. Transgenic mice overexpressing COX-2 in the colon did not develop tumors spontaneously, but did have

a higher tumor load compared with wild-type mice following AOM treatment [201]. Similar observations were found in skin and gastric cancers [202] [203]. Prostaglandin E2 (PGE2) a major COX-2 dependent prostaglandin is responsible for the protumorigenic effects of COX 2 and is highly expressed in CRC [204]. An enzyme 15-hydroxyprostaglandin dehydrogenase (15-PGDH) degrades PGE2 to inactive 15-keto PGE2 metabolite and loss of 15-PGDH expression correlates with tumor formation including colon and lung cancers [205-207]. Some studies indicate that 15-PGDH acts as tumor suppressor in colorectal cancers [208, 209]. PGE2 production is significantly higher in malignant tissues compared to normal tissues and several reports shows that chemopreventive actions of NSAIDs are mainly due to inhibition of PGE2 signaling [210, 211]. PGE2 contributes to the tumorigenesis by binding with PGE2 receptors (EP1-EP4), which belongs to G-protein coupled receptor superfamily. Sonoshita *et al.* [212] first reported the involvement of EP receptors in colorectal cancer progression by crossing APC^{Min/+} mice with various homozygous mutants of EP receptors. Crossing of EP^{-/-} mice with APC^{Min} results in decreased size and number of polyps and VEGF production is also significantly decreased in the polyps. Several other studies also investigated the role of EP receptors in cancer progression using various pharmacologic inhibitors of EP receptor signaling. In APC^{Min} mice treated with an EP1-selective antagonist, a 40% reduction of polyp burden was observed, and EP1^{-/-} mice treated with carcinogen resulted in 60% suppression of ACF formation [212]. APC^{Min} mice treated with an EP4 selective antagonist exhibited decreased ACF formation by 67% and EP^{-/-} mice treated with carcinogen led to 56% reduction of ACF [213]. Growth of sarcoma 180 and Lewis lung carcinoma xenografts in EP3 null mice was significantly reduced, indicating a role for EP3 [214]. Chang *et al.* reported high expression EP2 and

EP4 and low expression of EP3 in mammary tumors compared with normal mammary tissue [215]. To date, all four EP receptors have been implicated in promoting tumorigenesis in different contexts, and it is plausible that EP receptors may have divergent functions in different cell types. In addition to EP receptor signaling, PGE₂ also activates Wnt signaling, PPAR- δ , and EGFR pathways (Fig. 1.14).

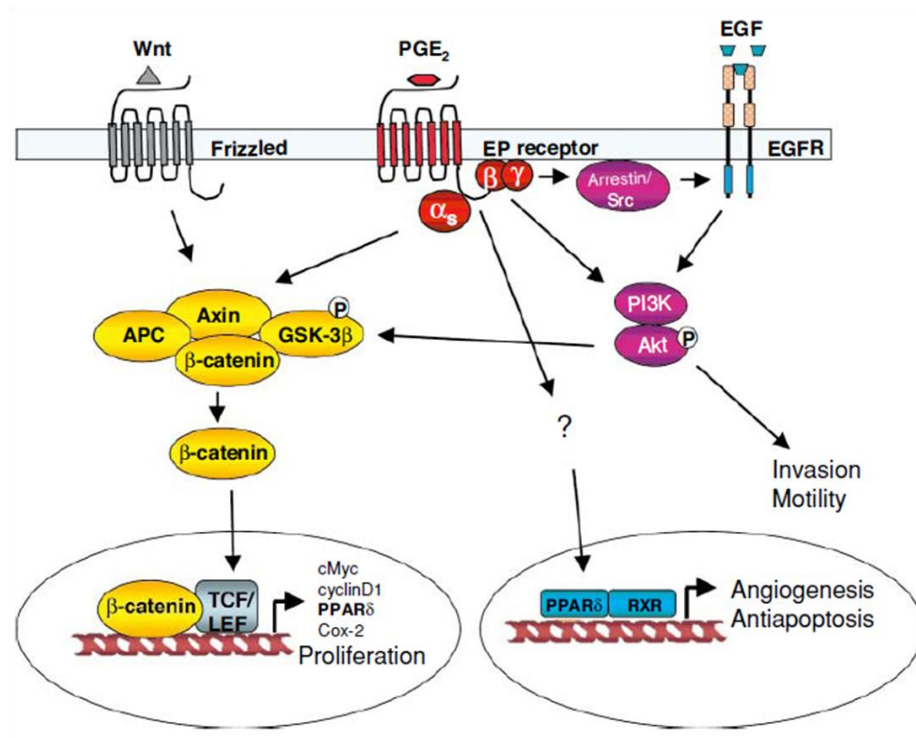

Fig.1.14. Crosstalk of PGE₂ with other signaling networks during colorectal cancer progression [216].

PGE₂ increases the phosphorylation of GSK-3 β to prevent β -catenin degradation resulting in nuclear accumulation of β -catenin and increased β -catenin/TCF mediated transcription of Wnt target genes such as cyclin D1, VEGF [217]. In addition

PGE₂ stimulation of EP₂ receptor results in association of G α subunit with the regulator of G protein signaling (RGS) and AXIN. This binding causes inactivation of GSK-3 β and results in accumulation of β -catenin in the nucleus and activation of Wnt target genes (Fig. 1.14) [218]. PGE₂ indirectly transactivates PPAR- δ through PI3K/Akt. PPAR- δ is a direct transcriptional target of β -catenin/TCF and indicates an important role in bridging Wnt and PGE₂ signaling downstream of β -catenin/TCF [219]. This suggests that PGE₂ acts both upstream and downstream of β -catenin to regulate PPAR- δ function (Fig. 1.14). Other studies show that PGE₂-induced migration and invasion of cancer cells through activation of EGFR. PGE₂ stimulates EP₄ receptors and form a complex with β -arrestin and c-Src and results in activation of EGFR and downstream Akt/protein kinase B (PKB) [220]. Overexpression of the EP₄ receptor was observed in several cancers and adenomas and inhibition of EP₄ with small molecule inhibitors decreased cell proliferation, invasion and motility in vitro [221, 222]. PGE₂ interacts with EGFR pathways to promote tumor growth and induce apoptosis. PGE₂ stimulates inhibition of apoptosis by activation of PI3K/Akt, while EGFR stimulates same pathway through Ras. PGE₂ stimulates EGFR signaling through shedding of active EGFR ligands from the plasma membrane and PGE₂ also activates EGFR directly via Src pathway stimulation (Fig. 1.14) [223-226]. In contrast, EGFR transactivation stimulates AP-1-mediated induction of COX-2 expression and thus PGE₂ expression resulting in a loop of cross-stimulation [223]. In conclusion, all these mediators of inflammation are important components of colorectal tumorigenesis at least in sporadic CRC [227]. COX-2 also promotes tumor angiogenesis by inducing production of angiogenic factors such as VEGF and basic fibroblast growth factor (bFGF), increasing tumor dissemination by altering the cell adhesive properties and inducing matrix metalloproteinase activity [228,

229]. Finally in myeloid cells, PGE₂ decreases expression of antitumorigenic IL-12 and increases expression of protumorigenic IL-23 [230].

Role of inflammation in metastasis of colorectal cancer. The role of inflammation in colon cancer metastasis is not well characterized due to the lack of suitable mouse models, however tumors from classical colon cancer models such as APC^{Min} and AOM+DSS, rarely metastasize and, therefore models of colon cancer metastasis were developed. Implantation of colon cancer cells orthotopically under the skin and also as intrasplenic or intravenous administration of cells can result in metastatic colonization of target organs. The inflammatory environment plays an important role in metastasis [231] and the first step of metastasis is characterized by EMT, which allow cancer cells to invade epithelial linings/basal membranes and reach efferent blood vessels or lymphatics. This process of EMT is basically regulated by TGF- β and is characterized by loss of E-cadherin expression by malignant epithelial cells [23, 85].

Overexpression of Fzd7, a Wnt receptor ligand increases motility & metastatic capabilities and activation of NF- κ B and STAT-3 resulting in EMT in colon cancer cells (Fig. 1.15) [232, 233]. In addition to TGF- β , EMT is also regulated by several pro-inflammatory cytokines, such as IL-1, IL-6, HIF-1 α , and TNF- α [234-236] and ZEB1, ZEB2, Twist, Kiss and Snail transcription factors that play a role in EMT [237]. Activated snail inhibits E-cadherin in epithelial cells and TNF- α stabilizes snail by preventing its degradation; this is one of the mechanism by which TNF- α promotes colon cancer metastasis (Fig. 1.15) [234].

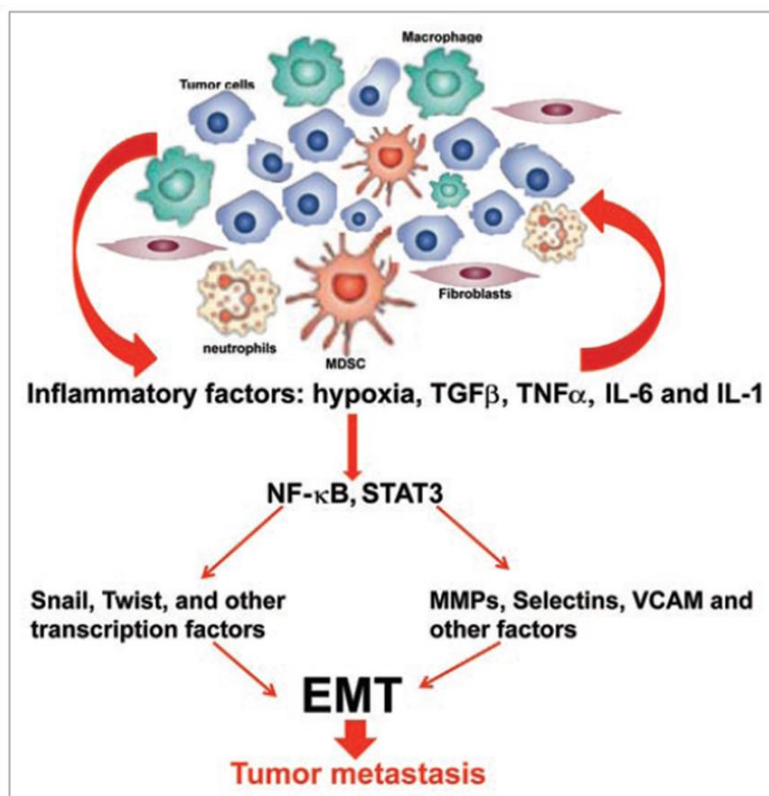

Fig.1.15. Signaling crosstalk between inflammatory cells and tumor cells. Tumor cells at the invasive front are surrounded by fibroblasts, macrophages, myeloid derived suppressors cells (MDSC) and neutrophils. Inflammatory cells produce $\text{TNF-}\alpha$, $\text{TGF-}\beta$, IL-6, IL-1, and other pro-inflammatory factors and thus activate $\text{NF-}\kappa\text{B}$ and STAT-3 pathways and induce EMT and metastasis in tumor cells [231].

Inflammatory signals also regulate the production and activity of proteases that facilitate invasion and metastasis by degradation of extracellular matrix. Human colon cancer cells express MMP 1, 2, 3, 7 & 9 and expression of various MMPs by stromal, immune and cancer cells provides the stimulus for cell migration and invasion [238].

DIAGNOSIS AND STAGING OF COLORECTAL CANCER

The diagnosis of colorectal cancer is based on symptoms, tissue biopsies, radiological techniques and biological markers. Except for obstructing or perforating cancers, the duration of these symptoms does not correlate with prognosis. The initial

stage of CRC does not produce any signs or symptoms and therefore intensive efforts for detection of CRC through screening tests are essential. Symptoms of colorectal cancer include but are not limited to bleeding, perforation, obstruction, intermittent abdominal pain, weakness, nausea and vomiting. CRC is also diagnosed by colonoscopy or sigmoidoscopy followed by tumor biopsies. Physical examination and complete colonoscopy is required to rule out metachronous tumor. Computed tomographic (CT) colonography of other organs such as chest, abdomen and pelvis is required to identify metastatic disease [239]. CT colonography is important for precise localization of the tumor and it also identifies other colon tumors or polyps that are undetected with colonoscopy due to obstructive lesions [240, 241]. For rectal cancers, it is essential to measure the tumor spread and high resolution MRI can be used to assess the spread of tumor in the surrounding mesorectum. In patients with suspected liver metastasis from colon cancers, spread of the tumors is determined by ultrasound, CT and MRI. Even though these imaging techniques are used to diagnose metastasis, new methods are required to characterize the liver metastasis. Biological markers are another tool for the diagnosis of colon cancer, but unfortunately reliable markers for colon cancer have not yet been identified [242]. CEA is the most widely studied marker that may be useful in preoperative staging and postoperative followup for large bowel cancers, however, CEA has low predictive value in diagnosis of asymptomatic patients [243]. Recently several carbohydrate antigens such as CA19-9 were examined and exhibit some promise regarding specificity for pre-neoplastic and early neoplastic lesions of colon [244]. Once diagnosis of CRC has been made, staging can be described based on tumor-node-metastasis (TNM) classification (Table. 1.4).

Table. 1.4. TNM classification of colorectal cancer based on clinical and pathological conditions [245].

<p>Primary tumour (T)</p> <p>TX: Primary tumour cannot be assessed</p> <p>T0: No evidence of primary tumour</p> <p>Tis: Carcinoma in situ: intraepithelial or invasion of the lamina propria</p> <p>T1: Tumour invades submucosa</p> <p>T2: Tumour invades muscularis propria</p> <p>T3: Tumour invades through the muscularis propria into the subserosa, or into the nonperitonealized pericolic or perirectal tissues</p> <p>T4: Tumour directly invades other organs or structures and/or perforates the visceral peritoneum</p> <p>Regional lymph nodes (N)</p> <p>NX: Regional nodes cannot be assessed</p> <p>N0: No regional lymph node metastasis</p> <p>N1: Metastasis in 1 to 3 regional lymph nodes</p> <p>N2: Metastasis in 4 or more regional lymph nodes</p> <p>Distant metastasis (M)</p> <p>MX: Presence of distant metastasis cannot be assessed</p> <p>M0: No distant metastasis</p> <p>M1: Distant metastasis</p>
--

TNM is a dual system that includes both clinical and pathological classifications. This classification is based on two different methods of examination and serves different purposes. The clinical and pathological classifications are designated as cTNM and pTNM, While TNM without any prefix implies the clinical classification, usually cTNM is the basis for the choice of treatment and pTNM is the basis for prognostic assessment

[246]. CRC is classified into different stages based on the pTNM classification (Table. 1.5).

Table.1.5. Correlation between TNM stage and 5-year survival in colorectal carcinoma [245].

TNM Stage		5-year survival
Stage 0, I	(Tis/1, N0, M0)	>90%
Stage I	(T1/2, N0, M0)	85–90%
Stage IIA/B	(T3/4, N0, M0)	70–75%
Stage IIIA	(T1/2, N1, M0)	77–91%
Stage IIIB	(T3/4, N1, M0)	54–63%
Stage IIIC	(T4; N2, M0)	26–37%
Stage IV	(M1)	<5%

Stage I CRC is equivalent to the Duke & Modified Astler-Coller (MAC) A or B1, in which the tumor is limited to bowel wall. Stage II is equivalent to the Duke & MAC B2 or B3, in which tumor has spread to extramural tissue. Stage III is equivalent to Dukes & MAC C1-C3, in which the tumor has spread to regional lymph nodes [247]. Patients having potentially curable colorectal cancers are classified based on their history, physical examination, laboratory data, intestinal evaluation and instrumental work-up such as CT scan, NMR and PET [248, 249]. Surgical staging of colorectal cancer includes an assessment of liver metastases, nodal spread of disease, and extension of tumors through the bowel wall and onto adjacent structures [250].

TREATMENT OF COLORECTAL CANCER

Treatment of CRC is based upon the stage of CRC and surgery is the potential treatment option for patients with curable colorectal cancer. Adjuvant therapy, such as

chemotherapy is administered to reduce the risk of recurrence and death. The recurrence rate depends on pathological staging of CRC and adjuvant chemotherapy is the standard method of treatment for stage III patients, but it is not well established in stage II patients.

Treatment of localized disease. Surgery is the common method of treatment for localized CRC. It includes wide resection of the involved bowel segment along with its lymphatic drainage. The extent of the resection is determined by the blood supply and distribution of regional lymph nodes [251]. Usually resection should include colon segments of at least 5 cm on either side of the tumor. Local excision or simple polypectomy is sufficient for treatment of stage 0 CRC, because the tumors limited to mucosa without invasion of the lamina propria. In stage I CRC, a wide surgical resection along with anastomosis is required because of its localized nature. In stage II CRC patients, wide surgical resection and anastomosis followed by adjuvant therapy is required in high risk patients, while in stage III CRC chemotherapy is the standard method of treatment because of the involvement of lymph nodes. Prognosis depends on the number of lymph nodes involved and patients have a decreased survival rate if 4 or more lymph nodes are involved [252]. The standard treatment option for this stage is a combination of oxiplatinin and 5-FU/LV (FOLFOX4 or FLOX). In special circumstances, monotherapy with capecitabine, UFT/LV or 5-FU/LV is used as an alternative for adjuvant chemotherapy. In conclusion, standard treatment options for localized CRC include wide surgical resection and anastomosis followed by postoperative chemotherapy with FOLFOX. In addition to FOLFOX, other adjuvant chemotherapeutic options are also considered for high risk colon cancer patients who have advanced stage II or stage III colon cancers. These regimens include i. infusional

FU/LV and oxiplatinin (FOLFOX4), ii. infusional 5-FU/LV alone for patients who cannot tolerate oxiplatinin, iii. Capecitabine alone may be considered for the patients who are not suited to FOLFOX and iv. Capecitabine/oxiplatinin (CAPOX) can be used instead of FOLFOX [245].

Treatment of metastatic CRC. Stage IV CRC is accompanied by distant metastatic disease and 25-30% of the patients will have metastasis at the time of colorectal cancer diagnosis. For stage IV, CRC therapy is primarily to prolong survival and maintain quality of life. A standard treatment option includes surgical resection of primary tumor/anastomosis, treatment of isolated metastasis, palliative chemotherapy, biological therapy and radiation therapy for the primary tumor and other sites of metastasis [253-256]. Palliative chemotherapy for metastatic CRC can improve survival, lessen symptoms and decrease liver only or lung only metastasis in patients with potential resectable disease. Combinations of fluorouracil with irinotecan, oxiplatinin and targeted drugs increase survival of patients and this combination has reduced toxicity and hence is commonly used [257]. Fluorouracil can be safely substituted for capecitabine when combined with oxiplatinin with no loss of efficacy [258, 259]. The sequence of drugs used at first presentation of disease and as the disease progresses seems to be less important in increasing the survival rather than exposure to all active drugs during treatment [260]. Even though an initial drug combination is commonly used, fluropyrimidine monotherapy is suitable for some patients [261, 262]. Treatment is continued until the disease regression or for a fixed duration depending upon the toxic side-effects, tumor response and preference of the patient [263, 264]. Progress in the management of metastatic CRC in the past 5 years has been made by addition of targeted treatments. Novel targeted therapies with drugs/ agents such as Bevacizumab,

a vascular endothelial growth factor inhibitor; Cetuximab and Panitumumab, monoclonal antibodies against the EGFR have increased the efficacy of treatment for metastatic CRC. In chemorefractory patients, cetuximab alone was active and reversal of irinotecan resistance can be observed when used with irinotecan [253]. The activity of cetuximab alone or in combination with irinotecan also gave improved responses in other studies [265, 266]. First line of treatment with combinations of cetuximab, fluorouracil and irinotecan marginally improved progression free survival [267]. Panitumumab has been approved as a monotherapy for pretreated patients and significantly improved progression free and survival rates when given in combination with fluorouracil and oxyplatinin to patients with tumors expressing wild-type K-Ras [268, 269]. Combinations of panitumumab, irinotecan and fluorouracil also improve progression-free but not overall survival in pretreated patients with wild type K-Ras tumors [270]. K-Ras mutation status is consistently used to monitor the response of patients to EGFR directed monoclonal antibodies and now cetuximab & panitumumab are the only drugs offered to patients with wild type K-Ras colorectal cancers. Rashes, diarrhea and hypomagnesemia are characteristic toxicities observed with anti EGFR drugs. Bevacizumab is a VEGF inhibitor which also causes normalization of tumor vasculature and improves delivery of the drug. Its side-effects include hypertension, gastrointestinal proliferation, bleeding, delayed wound healing and thromboembolism. Combinations of Bevacizumab, irinotecan and fluorouracil improves the response rates by 10% in untreated metastatic colon cancer patients, and significantly prolonged the survival rates in pretreated patients [254]. Bevacizumab was approved as first line of treatment for metastatic colorectal cancers in combination with fluoropyrimidine-based chemotherapy and is widely considered as the standard first-line treatment. Cetuximab

received regulatory approval in 2004 as a monotherapy for chemotherapy-resistant patients and panitumumab was approved in 2006 for patients having wild type K-Ras pretreated tumors. Despite the use of active targeted drugs for treatment of metastatic CRC in the past decade, improvement in overall survival has increased by 2 years; however, overall cure rates have remained low. The parallel development of predictive molecular and clinical biomarkers will help to achieve the best outcomes for targeted therapies and K-Ras is currently the only validated molecular biomarker in CRC for predicting a positive response to EGFR-directed monoclonal antibodies. Clinical and translational research that is in progress will hopefully provide personalized medicine and other predictive biomarkers for management of CRC.

MECHANISM BASED ANTICANCER DRUGS

Most current chemotherapeutic drugs are accompanied by severe side effects and toxicity, and thus have led to development of new target therapies with decreased toxicity. These mechanism based anticancer drugs are highly promising for treatment of several cancers, since these agents are more tumor-specific and include drugs such as kinase inhibitors, antibodies that block various signaling modules, immunotherapies and genomic therapies that involve knock down of specific oncogenes and re-expression of tumor suppressor genes. Applications of mechanism based drugs are highly tumor-specific such as treatment of non small cell lung cancer patients with specific EGF receptor mutations with EGF receptor inhibitors erlotinib and gefetinib [271, 272].

Targeted therapy of colon cancer. Currently there are 7 FDA approved drugs for treatment of metastatic CRC (Table. 1.6). These drugs are usually used in combination however; some drugs are administered as single agents. Recently the national comprehensive cancer network (NCCN) proposed 12 possible different drug

combinations for first line of treatment in metastatic CRC patients. Given the availability of these drugs and their complexity in the current treatment paradigms, it is important to understand the efficacy and toxicity profile of these agents in order to provide better therapies for individual patients.

Table. 1.6. Drugs approved for treatment of metastatic colon cancer [273].

Drug	Category	Mechanism of action	FDA indication
<i>5-FU/LV</i>	Antimetabolite (pyrimidine analog)	Non-competitive inhibition of thymidylate synthase	1991: palliative treatment of colon cancer
<i>Oxaliplatin</i>	Alkylating agent (platinum)	Inhibits DNA synthesis by forming inter and intra strand crosslinks with DNA	2002: 2nd line with 5-FU, after irinotecan failure 2004: 1st line with 5-FU
<i>Irinotecan</i>	Camptothecin	Inhibits topoisomerase I, producing DNA breaks	1998: 2nd after failure of 5-FU based therapy 2000: 1st line with 5-FU/LV
<i>Capecitabine</i>	Antimetabolite (pyrimidine analog)	Prodrug of 5-FU	2001: 1st line when treatment with fluoropyrimidine therapy alone is preferred
<i>Bevacizumab</i>	Humanized monoclonal antibody	Binds to VEGF, inhibiting interaction between VEGF and its receptor	2004: 1st line with 5-FU based therapy 2006: 2nd line with 5-FU based therapy
<i>Cetuximab</i>	Recombinant, chimeric, monoclonal antibody	Binds to EGFR, inhibiting binding of EGF	2004: single agent or with irinotecan, on irinotecan refractory or intolerant 2009: amended only for patients with KRAS lacking mutations in codon 12 and 13
<i>Panitumumab</i>	Recombinant, human, monoclonal antibody	Binds to EGFR, inhibiting binding of EGF	2006: single agent on chemorefractory 2009: amended only for patients with KRAS lacking mutations in codon 12 and 13

- 1. 5-Fluorouracil (5-FU).** It is a pyrimidine analog which belongs to a group of antimetabolite drugs and works through non-competitive inhibition of the enzyme, thymidylate synthase. It requires ribosylation and phosphorylation to form specific metabolites associated with its cytotoxicity. Metabolites of 5-FU such as, triphosphatefluridine (FUTP) are incorporated into RNA and fluorodeoxyuridine monophosphate (FdUMP) inhibits thymidylate synthesis, which is necessary for DNA replication. 5-FU also inhibits activity of an exonuclease complex essential for cell survival. 5-FU is an S-phase specific drug and induces cell cycle arrest and apoptosis. 5-FU is administered as an infusion and/or intravenous bolus every 2 weeks and the dose will depend on the combination of drugs used. Typically 5-FU is used in combination with folinic acid (leucovorin (LV)), which enhances its cytotoxicity by increasing formation of ternary complexes with thymidylate synthase. Metabolic degradation of 5-FU occurs in liver by dihydropyrimidine dehydrogenase (DPD). The most common adverse side-effects with this drug are fatigue, stomatitis, diarrhea, nausea, myelosuppression, increased pigmentation and atrophy of the skin. Several studies have evaluated the role of 5-FU/LV in metastatic CRC treatment with different regimens and methods of administration and show that 5-FU/LV should be administered as continuous infusion in order to obtain maximum efficacy. This combination of 5-FU/LV is frequently in clinical trials as a reference comparison with newer drug combinations [274, 275].
- 2. Oxaplatinin.** This platinum analog belongs to third generation diamminocyclohexane (DACH). Platinum analogs which are converted to their active metabolites such as monoquo and diaquodiaminocyclohexane platinum which covalently bind to DNA. Oxiplatinin interchelates with DNA through interstrand and intrastand crosslinks and

inhibits DNA synthesis & function resulting in tumor cell death in all stages of cell cycle. Oxiplatinin also binds to both cytoplasmic and nuclear proteins and induces cytotoxicity and antitumor effects. Oxiplatinin is rapidly distributed to the tissues and undergoes biotransformation; the major route of elimination is via renal clearance. The most common observable side-effects with platinum analogs are nausea, vomiting, diarrhea, fatigue, myelosuppression and peripheral neuropathy. Oxiplatinin is considered as a second line therapy for treatment of colon cancers, since FOLFOX4 (5-FU/LV+oxiplatinin) is superior when compared to 5-FU/LV (reference). Oxiplatinin was considered to be inactive as a single agent and is administered in combination with 5-FU/LV. The adverse effects of FOLFOX4 include diarrhea, neuropathy and neutropenia which interfere with patient's quality of life [276-278].

- 3. Irinotecan.** Irinotecan is derived from camptothecin, a natural phytochemical obtained from *Camptotheca acuminata*. Irinotecan is an S-phase specific drug which binds and inhibits the topoisomerase I-DNA complex and induces single and double stranded DNA breaks leading to cell death. Irinotecan is activated by hydrolysis to SN-38, which is 1000 times more potent than irinotecan as an inhibitor of topoisomerase I and conversion of irinotecan to SN-38 is mediated by a carboxylesterase enzyme in the liver; SN-38 is conjugated in the liver by the enzyme glucuronosyltransferase 1A1 (UGT1A1) to form an inactive metabolite SN-38 glucuronide that is eliminated through urine and bile. SN-38 metabolism is affected in patients with hepatic dysfunction and/or inherited UGT1A1 mutations (Gilbert's syndrome). Therefore patients with these disorders are at increased risk for irinotecan induced toxicity. SN-38 glucuronide is in turn converted into active SN-38 by beta-glucuronidases in the human intestine. The most observable side

effects include diarrhea, myelosuppression, nausea, vomiting and fatigue. Initially this drug was adopted as second line therapy, but it is highly effective as first line therapy, in IFL, FOLFIRI regimens, which is a combination of irinotecan with 5-FU/LV [279, 280].

- 4. Capecitabine.** Prodrug Capecitabine is an orally administered fluoropyrimidinecarbamate which is absorbed in gastrointestinal tract and rapidly metabolized to 5-FU. Thymidine phosphorylase which is highly expressed in several cancers is the enzyme involved in the final conversion to 5-FU. This approach has some advantages over infusional 5-FU, since the active drug attains maximal concentrations in tumors with high efficacy and less toxicity. The mechanism of action of this drug is the same as 5-FU and is administered along with oxiplatinin and irinotecan. The commonly observed side-effects are nausea, diarrhea, stomatitis and fatigue. Unfortunately capecitabine has higher incidence of hand foot syndrome when compared to intravenous 5-FU. There are significant interactions with other drugs such as warfarin and phenytoin and capecitabine should be used with caution in patients with liver dysfunction. Several studies on capecitabine as a replacement for 5-FU in combination with oxiplatinin and also compared with FOLFOX gave similar results.
- 5. Bevacizumab.** Bevacizumab (Avastin) is a humanized monoclonal antibody that targets VEGF. Angiogenesis is the process of development of new blood vessels and is important in wound repair, tissue remodeling and inflammation. It is a multistep process involving vasodilation, increased vascular permeability, stromal degradation, endothelial cell proliferation and migration which results in formation of new capillaries [281]. The process of angiogenesis is regulated by several factors

and their cognate receptors such as VEGF, PDGF, FGF and TGF- α (Fig. 1.16). The most studied pathway in the process of angiogenesis involves VEGF and its receptors (VEGFR) [282].

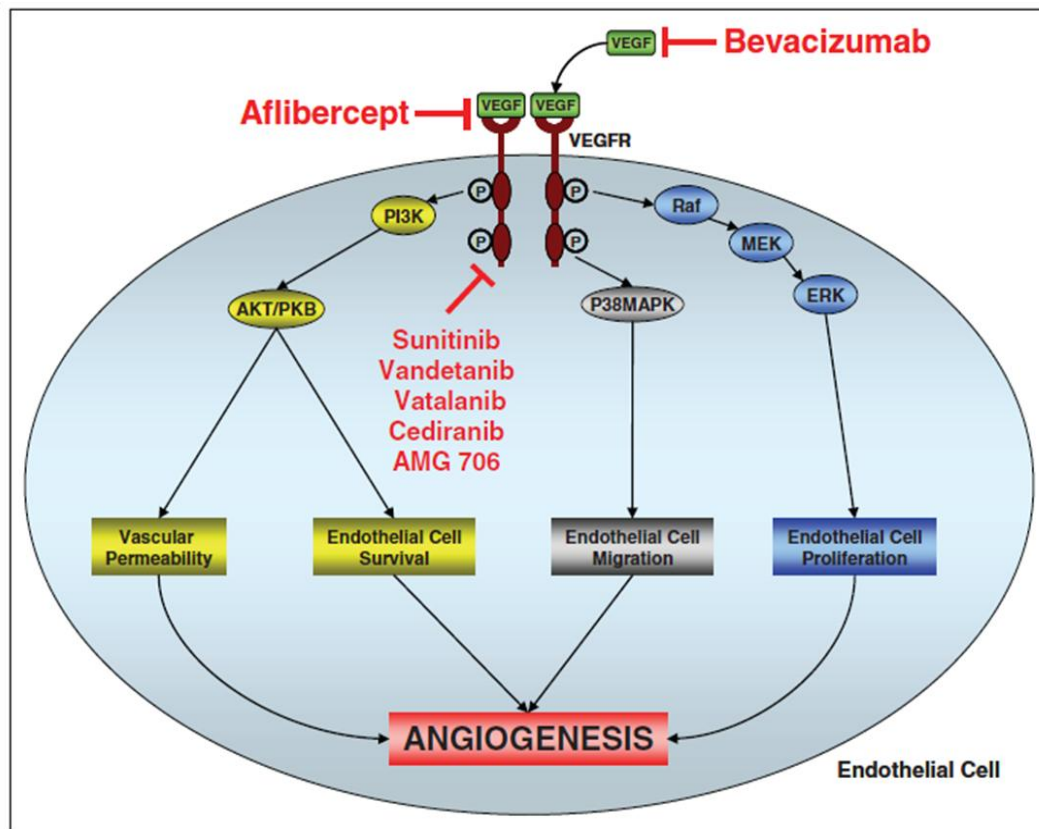

Fig.1.16. VEGF signaling pathway [283].

The VEGF family contains VEGF A-E with VEGF-A being the most important mediator of angiogenesis. VEGF-A expression is regulated by differentiation, transformation and hypoxia. It is also regulated by a number of cytokines, hormones, and growth factors such as EGFR, IL-1b, PGE2, IGF-1 [284, 285]. VEGF is a soluble growth factor secreted by tumor cells and stromal cells and acts by

binding to the extracellular domain of VEGFRs and the intracellular domain of these receptors contains the catalytic tyrosine kinase domains. VEGF-A primarily binds to VEGFR2 and activates endothelial cell survival, proliferation, migration, differentiation and increases vascular permeability. VEGF expression plays an important role in metastasis and overexpression of VEGF correlates with tumor progression and poor prognosis in CRC patients [286, 287]. In CRC, increased VEGF expression was observed in human liver metastases from primary CRC and expression of VEGFR was also increased in liver metastases compared with adjacent normal hepatic tissue [288].

A number of anti-angiogenic agents are undergoing clinical trials. Bevacizumab is a monoclonal antibody against VEGF-A that inhibits VEGF interactions with its receptors on the surface of endothelial cells thus inhibiting growth of blood vessels and the supply of blood, oxygen and nutrients to tumors. Bevacizumab in combination with chemotherapy is highly effective due to additive suppression of tumor growth, induction of apoptosis and enhanced the delivery of anticancer agents to the tumor by normalization of blood vessel architecture [289]. Bevacizumab was first approved based on its ability to increase the survival in metastatic CRC patients and is administered as an intravenous infusion every 2 weeks; bevacizumab is usually administered along with bolus IFL or with FOLFOX. Gastrointestinal perforation, impaired wound healing, bleeding, myocardial infarctions, strokes and nephritic syndrome are the side-effects of bevacizumab and the antibody [290]. Bevacizumab should not be administered for at least 4 weeks prior and 4 weeks after surgical procedures due to impaired wound healing. Other minor adverse effects include diarrhea, hypertension, asthenia, headache,

stomatitis, and leucopenia. Bevacizumab was the first biological agent approved by the US-FDA as a component of anticancer therapy in 2004. This approval was based upon pivotal study conducted by Hurwitz et al [254] which showed increased response rates and progression free survival, when bevacizumab was given along with IFL regimen (Irinotecan, 5-FU bolus, Leucovorin) in previously untreated metastatic CRC patients. Addition of bevacizumab to chemotherapeutic drugs increased the response and survival rates in most regimens including second and third line therapies. However there are a few exceptions such as addition of bevacizumab to FOLFOX failed to increase the response rate in previously untreated metastatic CRC and resected non-metastatic CRC patients [291].

Other anti-angiogenesis drugs and their targets. Several other angiogenesis inhibitors are being investigated. Aflibercept is a potent VEGF inhibitor produced by recombinant fusion of human VEGFR extracellular domain and Fc portion of human IgG1. It was active as a single agent for metastatic CRC and effective in combination with other standard chemotherapies [292]. Vatalinib is another antiangiogenesis agent which inhibits VEGFR-1, 2, &3 mediated angiogenesis and decreased tumor growth and metastasis in preclinical models of CRC [293, 294]. Sunitinib is multi tyrosine kinase inhibitor targeting VEGFR, PDGFR, c-KIT, RET, & LT3 and is approved for renal cancer patients [295]. Additional anti-angiogenic agents, such as cediranib (AZD2171), and AMG706 stabilize metastatic CRC patients in phase I trials and are now being investigated in phase II trials [296, 297].

- 6. Cetuximab and Panitumumab.** Cetuximab and Panitumumab are inhibitors of EGFR which belongs to the HER family of receptor tyrosine kinases that includes EGFR (ErbB1/HER1), ErbB2 (HER2/neu), ErbB3 (HER3) and ErbB4 (HER4) [298].

These receptor tyrosine kinases are activated by ligands such as EGF, TGF- α . Receptor activation induces receptor homo/hetero dimerization and autophosphorylation of C-terminal tyrosine residues and results in activation of downstream signaling cascades such as the Ras/Raf/MAPK, the PI3K-Akt pathway, PKC, STAT, and src kinase pathways, which are responsible for cell proliferation, invasion, migration, and inhibition of apoptosis (Fig. 1.17).

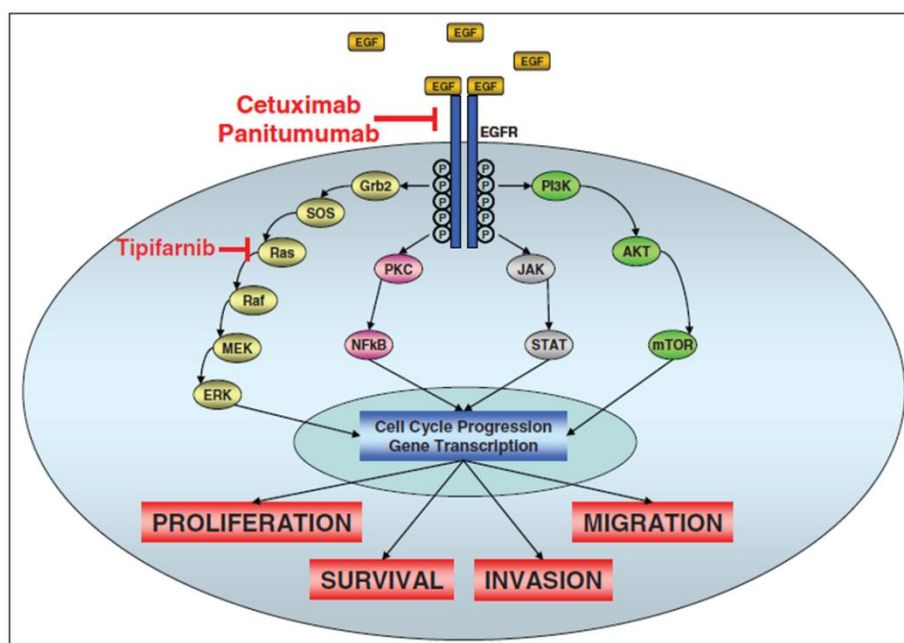

Fig. 1.17. EGFR signaling pathway [283].

EGFR activation activates multiple signaling pathways [299] and anti-EGFR therapy includes EGFR mAb's and small molecule inhibitors of EGFR tyrosine kinase activity (TKIs) [299]. Cetuximab (Erbix) is a recombinant human/mouse chimeric monoclonal antibody that binds specifically to the extracellular domain of EGFR. It is made up of Fv regions of a murine anti-EGFR antibody with human IgG1 heavy and

kappa light chain constant region. Panitumumab (Vectibix) is recombinant human IgG2 kappa monoclonal antibody which binds the extracellular domain of EGFR. EGFR is highly constitutively expressed in several human cancers including CRC and cetuximab mAb binds specifically to EGFR and inhibits the binding of EGF and other ligands, thereby inhibiting phosphorylation and activation of receptor associated kinases and this result in induction of apoptosis, growth inhibition and decreased VEGF & MMP production. It also prevents receptor dimerization through steric inhibition of the extracellular domain and promotes receptor internalization, resulting in receptor degradation and reduced cell surface expression of EGFR. Cetuximab also kills the tumor cells by cell-mediated cytotoxicity (ADCC) and complement fixation. The mechanism of action of panitumumab is similar to cetuximab. The most common side effects with these drugs include acneiform, rash, fatigue, dyspnea, nausea, hypomagnesemia and diarrhea.

Cetuximab and panitumumab are approved for treatment of CRC. Cetuximab was approved by US-FDA in 2004 in combination with irinotecan for irinotecan-resistant disease or as a single agent in irinotecan intolerant patients [253]. Panitumumab received FDA approval based on similar study with fluoropyrimidine-, oxaliplatinin-, irinotecan-containing chemotherapy regimens in EGFR expressing CRC patients [300]. Even though, anti-EGFR antibodies are clinically safe and active in CRC, tyrosine kinase inhibitors (TKIs) as single agents exhibit minimal activity in metastatic CRC. Combinations of TKIs with fluoropyrimidine-, oxaliplatinin-, irinotecan-containing chemotherapy regimens increased the clinical response rates in phase II trials, but the trials closed prematurely because of severe adverse effects. However, Anti-EGFR therapy in combination with cetuximab,

irinotecan and oxaliplatin increased the response rate by 77%. Combinations of panitumumab with standard chemotherapy resulted in worse outcomes in patients who received panitumumab. Thus anti-EGFR therapy as firstline therapy for metastatic CRC is unclear and several trials are ongoing to address the unanswered questions. Similarly the role of cetuximab in the adjuvant treatment of CRC is currently under study in phase III clinical trials.

7. Novel therapies

mTOR inhibitors. Mammalian target of Rapamycin (mTOR) is a serine threonine kinase which belongs to PI3K family of kinases. mTOR is activated in response to growth factors and results in phosphorylation of translational regulators such as eukaryotic initiation factor 4E-binding protein and p70s6 kinase. Inhibitors of mTOR induce apoptosis and arrest cell cycle in late G1 by down regulation of cyclin/CDK complexes and activation of the cell cycle inhibitor p27. mTOR inhibitors also inhibit angiogenesis by preventing endothelial and vascular smooth muscle cell proliferation. mTOR inhibitors are analogs of rapamycin that bind to immunophilin FK506/rapamycin-binding protein to inhibit its function. The efficacy of mTOR inhibitors has been demonstrated in preclinical models and recently temsirolimus, an mTOR inhibitor was approved for treatment of metastatic renal cancer [301]. RAD-001, another mTOR inhibitor was in phase II clinical trials and showed promising effects in treatment of metastatic CRC [302]. The mTOR inhibitors are likely to be more effective when combined with traditional chemotherapy and several clinical trials of mTOR inhibitors in combination with other agents is underway.

Protein kinase C (PKC) inhibitors. PKC is a serine threonine kinase activated downstream from EGFR and VEGFR receptor tyrosine kinases. Activation of PKC

plays an important role in cell signaling pathways that lead to tumor growth and survival, and PKC activity and expression is highly elevated in several cancers and tumors including CRC. Enzastaurin is a potent inhibitor of serine/threonine kinases and targets PKC, PI3K/AKT and GSK3. It was considered to be safe as single agent or in combination with 5-FU or bevacizumab [303, 304]. Currently combinations of enzastaurin, bevacizumab and 5-FU are in phase II clinical trials and show great promise.

Src inhibitors. The proto-oncogene Src is a non receptor tyrosine kinase which plays an important role in cancer cell proliferation, angiogenesis, invasion, metastasis and regulation of apoptosis [305]. Src is activated downstream of several signaling cascades including growth factor receptor activation and enhanced Src activity has been observed in 80% of CRC patients. Src activity levels correlate with enhanced metastasis, and resistance to chemotherapy. AZD0530 is an orally administered Src inhibitor that prevents CRC metastasis in stabilized disease in phase II clinical trials [306]. Another src inhibitor, dasatinib in combination with FOLFOX and erbitux is currently in clinical trials.

Kinesin spindle protein (KSPs). Mitotic kinesins, such as KSP are important for the mitotic spindle, providing the propulsive forces required to separate centrosomes during prophase [307]. These proteins are expressed in proliferating cells and provide an attractive target for anticancer therapy [308]. Ispinesib (SB-715992) is a potent small molecule inhibitor of KSP and has been in phase II clinical trials as a single agent, but combination chemotherapy studies have not been performed [309].

In conclusion, the treatment options and the expectations for CRC patients has changed dramatically over the last 10 years and an increasing number of new agents aimed at a variety of targets are being investigated. Some of these agents include tyrosine kinase and histone deacetylase inhibitors, and PPAR agonists. Promising pre-clinical effects and activity have been observed in phase I CRC studies. Furthermore, many phase II clinical trials on these novel agents in combination with standard chemotherapy are also highly effective.

TRANSCRIPTION FACTORS AS DRUG TARGETS

Many current targeted therapies have focused at cell surface proteins, however, recent studies show that intracellular proteins, such as transcription factors can also be drug targets. A single transcription factor activates multiple signaling cascades and also regulates expression of genes involved in the oncogenic process, and therefore modulating the activity of a transcription factor can be a highly effective treatment modality. In order to consider a protein as therapeutic target, it has to satisfy important criteria such as,

- a. The target protein should be expressed/overexpressed in cancer cells but not in normal cells
- b. The target protein should be involved in one or more malignant pathways including cell proliferation, resistance to apoptosis, invasion, metastasis and angiogenesis
- c. Inhibition of target protein expression/function should inhibit the malignant process
- d. Exogenous expression of the target protein should enhance the tumorigenesis.

- e. The target protein should be “druggable”.
- f. The target should have limited homology with related genes/proteins to avoid cross reactivity and undesirable off-target effects.

In general, gene transcription is regulated by the transcriptional machinery (TF's, RNA polymerase II, activators and co-activators) and transcriptional regulatory elements such as promoters, enhancers, silencers, insulators and locus control regions [310, 311]. Dysregulation of transcription and subsequent post transcriptional processes can result in cancer initiation, persistence, repression and temporal/spatial dyscoordination as well as structural changes including mutations and translocations [311]. Several TF's are associated with cancer and the transcriptional machinery & transcriptional regulatory elements are novel therapeutic targets and understanding transcriptional regulatory networks has revealed their critical role in the development of cancer. Several TF's are associated with hallmarks of cancer and contribute to the development of tumor specific phenotypes (Table. 1.7).

Table.1.7. Hallmark characteristics of transcription factors [312].

Transcription factor	Hallmark traits					
	Self-sufficiency in growth signals	Insensitivity to growth-inhibitory signal	Evasion of programmed cell death	Limitless replicative potential	Sustained angiogenesis	Tissue invasion and metastasis
AP-1	X		X		X	X
AR	X					
ATF-1						X
BRN-3b		X				
C/EBP α		X				
CREB			X		X	
E2F-1				X		
ETS-1					X	X
EWS/ETS				X		
FOX03a			X			
HIF-1 α /HIF-1 β (ARNT)					X	X
Myc	X				X	X
NF- κ B	X		X		X	X
PEA3						X
RAR α	X					
RB1				X		
Sp-1		X	X		X	X
STAT3		X	X		X	
STAT5		X	X			
TP53			X			

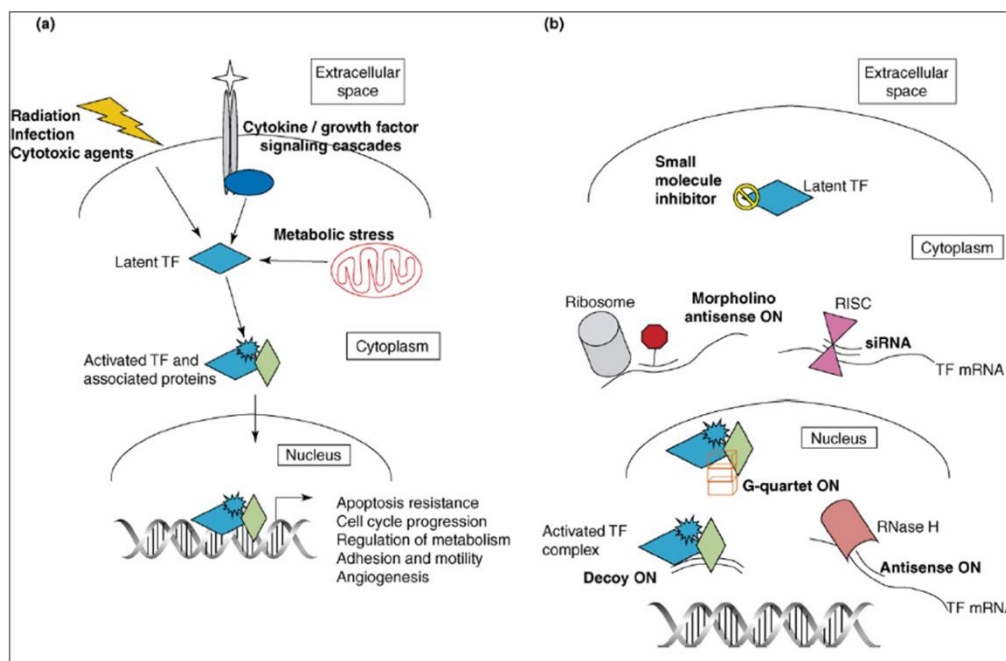

Fig.1.18. Transcription factors are attractive targets for cancer treatment. (a) Transcription factors play a critical role in carcinogenesis. (b) Transcription factors can be targeted at multiple levels.

Extracellular signals, cytotoxic exposures or cytokines that bind to their receptors, initiate signaling cascades that result in activation of nuclear transcription factors. In some cases, TF's including STAT proteins, NF- κ B, hypoxia inducible factor-1 (HIF-1) and β -catenin are latent in the cytoplasm until activated by an appropriate signal. Once activated, the TFs undergo homo/heterodimerization (e.g. STAT dimers, NF- κ B dimers or β -catenin/T-cell factor complexes) and translocate into the nucleus. Inside the nucleus, the TF complex binds to specific DNA response elements and regulates expression of genes that promote pro-oncogenic pathways (Fig. 1.18). Transcription factors can be targeted at multiple levels; the mRNA encoding the targeted TF can be bound in the nucleus by antisense oligonucleotide (ON) or

alternatively, the TF mRNA can be targeted by morpholino antisense ONs, which sterically inhibit translation in the cytoplasm. RNA interference with short inhibitory RNA (siRNA) duplexes leads to degradation of the mRNA by RNA-induced silencing complex (RISC). Small molecules commonly exert their action by keeping the latent TF's sequestered in the cytoplasm or by preventing a critical activation event, such as recruitment of an activated receptor complex, phosphorylation or dimerization. Activated TFs in the nucleus can be prevented from binding DNA response elements by decoy ONs that mimic the DNA sequence of the response element. For example, G-quartet ONs inhibit the binding of STAT-3 to the DNA response element. In vitro experiments with primary cell lines, tumor cells and in vivo experiments with animal models are necessary for determining efficacy of specific transcription factors in clinical trials and Table. 1.8 summarizes details regarding TF's involved in preclinical studies.

Table. 1.8. Summary of preclinical studies involving transcription factors as drug targets [312].

Transcription factor	Justification summary	Reference
AP-1 (c-Jun)	Inhibition-reduced breast cancer cell proliferation in mice	Liu <i>et al.</i> [313]
AR	Downregulation resulted in prostate tumor size reduction in mouse xenografts	Eder <i>et al.</i> [314]
ATF-1/CREB	Knockdown in mice resulted in subcutaneously transplanted tumor-size reduction through apoptosis	Jean [315]
BRN-3b (POU)	Results suggest that Brn-3b elevation in breast cancer is a significant transcription factor in regulating mammary cell growth	Dennis <i>et al.</i> [316]
C/EBPa	C/EBPa knockout mice showed abnormal lung cancer cell proliferation	Halmos <i>et al.</i> [317]
CREB	Transfected mice with CREB300/310 dramatically enhances tumor growth, whereas CREB300/310/133 inhibits the growth of the implanted tumor cells	Abramovitch <i>et al.</i> [318]
E2F-1/RB1	Knockdown of E2F of mouse embryonic fibroblast leads to phosphorylation of RB1. The result is cell proliferation	Wu <i>et al.</i> [319]

Table. 1.8 continued

Transcription factor	Justification summary	Reference
ETS-1	Overexpression in a rat hind limb ischemia model led to angiogenesis by increasing HGF and VEGF	Hashiya <i>et al.</i> [320]
EWS/ETS	EWS/ETS fusion activated telomerase in Ewing's sarcoma cells and appears to activate the transcription of hTERT as a transactivator	Takahashi <i>et al.</i> [321]
FOX03a	<i>C. elegans</i> Daf16, an ortholog to FKHRL1, FKHR and AFX, is the major output of insulin signaling	Lee <i>et al.</i> [322]
HIF-1a/HIF-1b (ARNT)	Shown to enhance neovascularization in the rabbit ischemic hindlimb model	Vincent <i>et al.</i> [323]
Myc	Overexpression in mice resulted in downregulation of IL-6- and VEGF-induced rabbit corneal angiogenesis	Hatzi <i>et al.</i> [324]
NF-kB	Bortezomib has completed phase II trials where the NF-kB pathway was downregulated in refractory multiple myeloma and relapsed myeloma patients	Richardson <i>et al.</i> [325]
PEA3	Use of a dominant-negative PEA3 delayed onset, reduced number and size of mammary tumors in mice	Bieche <i>et al.</i> [326]
RARa	Downregulation of RARa resulted in lymphoma in 44% of homozygous transgenic mice	Manshouri <i>et al.</i> [327]
SP-1	Nude mice trial using celecoxib-affected Sp1-binding sites on VEGF gene expression and limited metastasis	Wei <i>et al.</i> [328]
STAT3	Nude mice xenografts provide a method of knocking down STAT3	Sun <i>et al.</i> [329]
STAT5	Downregulation of STAT5b mediates proliferation of SCCHN cancer cells	Leong <i>et al.</i> [330]
p53	Adenovirus-mediated wild-type <i>p53</i> gene transfer with chemotherapy and radiation therapy inhibits progression of lung cancer growth in animal models with minimal toxicity	Nishizaki <i>et al.</i> [331]

Targeting TFs as a therapeutic option in cancer patients depends on selectivity and specificity. TFs from the same family also have similar or shared motifs, or structures, but different functions, (for example STAT-1 versus STAT-3, c-jun versus jun B) and this presents a challenge for the treatment to be effective. Increased knowledge of mechanisms of transcription and the transcription regulatory networks has led to a better understanding of their role in cancer and has facilitated rational drug design. Computer modeling can also help to improve the affinity and specificity in targeting TFs and Table. 1.9 summarizes the advantages and disadvantages of different approaches.

Table. 1.9. Comparison of different technologies in targeting TF's.

Targeting method	Stage of development	Advantages	Disadvantages	Refs
Small molecules	Clinical	<ul style="list-style-type: none"> • Can usually be administered without delivery vehicle 	<ul style="list-style-type: none"> • Affinity and/or specificity may be relatively low • screening process required 	[332]
Antisense	Clinical trials for c-Myc and some non-TF targets	<ul style="list-style-type: none"> • High specificity and affinity for target mRNA 	<ul style="list-style-type: none"> • Degraded unless modified • Delivery vehicle is required to get into cells 	[333]
RNAi	Clinical for intravitreal injection; preclinical for systemic use	<ul style="list-style-type: none"> • High specificity and affinity for target mRNA • Highly efficient degradation of target mRNA 	<ul style="list-style-type: none"> • Degraded unless modified • Delivery vehicle is required to get into cells 	[334]
Decoy	Preclinical	<ul style="list-style-type: none"> • High specificity and affinity for TF^b 	<ul style="list-style-type: none"> • Degraded unless modified • Delivery vehicle is required to get into cells 	[335, 336]
G-quartet	Preclinical	<ul style="list-style-type: none"> • Long half-life within cell due to nuclease-resistant structure 	<ul style="list-style-type: none"> • Delivery vehicle is required to get into cells 	[337, 338]

Recent advances in delivery vehicles and directed targeting (for example, liposomes, nanoparticles and aptomers) along with more accurate and potent effectors (for example, shRNA, siRNA, ribozymes, antisense ONs, and small molecule inhibitors) will be important for targeting TFs in a clinical setting.

SPECIFICITY PROTEIN (Sp) TRANSCRIPTION FACTORS AS DRUG TARGETS

Sp transcription factors. Sp transcription factors belong to Sp/KLF (kruppel-like factor) family of transcription factors which contains three conserved Cys2His2 zinc fingers in the DNA binding domain.

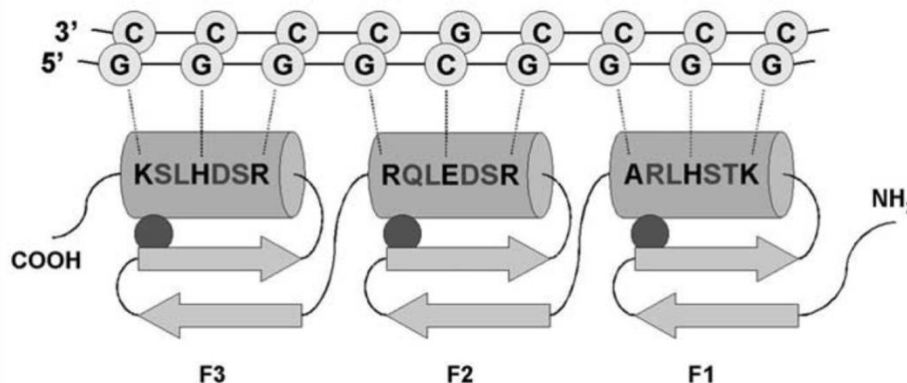

Fig. 1.19. The zinc fingers of Sp/KLF transcription factors. Individual fingers (F1, F2, and F3) are depicted as a β -sheet (arrows) and a α -helix (cylinder) held together by a zinc ion (dark grey sphere). GC box is shown as a double array of beads on strings with the nucleotide pairs partially overlapping. The amino acids in the α -helices are indicated, and interactions between critical residues (black) in each finger and a specific triplet of nucleotides of the GC box are shown with dotted lines [339].

Sp1 was the first transcription factor identified and binds to DNA with KHA, RER and RHK amino acids in the three zinc fingers respectively. Both Sp and KLF family of transcription factors binds to GC-(GGGGCGGGG) and GT-(GGTGTGGGG) boxes, but with different affinities due to alterations in the amino acid sequences in the zinc fingers (Fig. 1.19). This accounts for the interaction of Sp1 with diverse GC rich promoters and regulation of several of Sp-dependent genes in normal and transformed cells [340-342]. All Sp proteins have similar zinc finger domains and N-terminal motifs. Sp1-Sp9 transcription factors have been grouped under the Sp subfamily based upon homology and chromosomal localization which is adjacent to the HOX gene cluster. Genetic regulation of transcription by Sp proteins is tightly controlled.

Structural and functional characteristics of Sp proteins. Sp proteins have similar modular structures and Sp1-Sp4 form a subgroup among Sp proteins based on their similarity. Of their respective glutamine rich transactivation domains A and B, serine

threonine rich sequences and C-terminal zinc finger DNA-binding region. All Sp proteins have a conserved button head (btd) and Sp boxes that are involved in transactivation and regulation of proteolysis respectively [343, 344]. Sp2 has only one glutamine rich domain and a different consensus binding site due to the substitution of histidine by leucine in zinc finger 1 [345]. Sp5-Sp8 proteins have several small domains in common with other Sp proteins and appear to be truncated forms of Sp1-Sp4 due to lack of their N-terminal regions. With the exception of the btd and Sp boxes, the N-terminal regions of Sp5-Sp8 are different from other Sp proteins and are closely related to each other (Fig. 1.20).

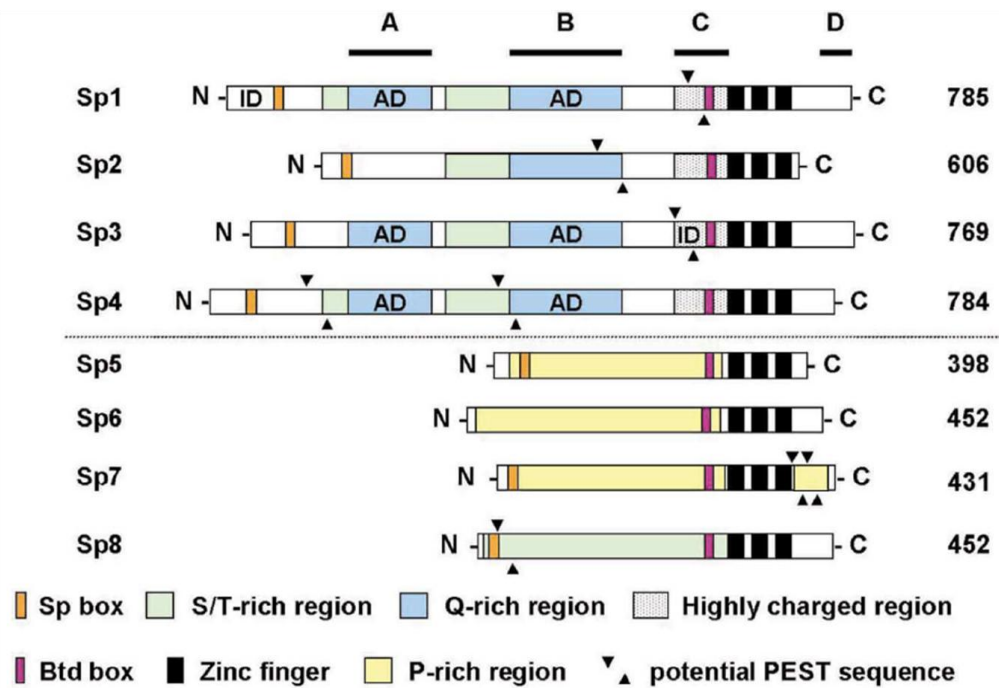

Fig.1.20. Structural motifs in Sp family proteins [339].

Sp1 regulates transcription from proximal promoters as well as distal enhancers and activation of domain B is important for multimerization and along with Domain A mediates superactivation of Sp1-dependent transcription [344, 346, 347]. Sp2 has a different binding specificity than other Sp proteins and therefore it is unable to activate transcription through GC boxes and its functions are cell specific. Sp2 has different characteristics compared to other Sp proteins due to single a transactivation domain, whereas two domains are necessary for superactivation and synergistic activation by Sp1 [347-349]. Although Sp3 and Sp4 are structurally similar to Sp1, some functional differences exist between these proteins. Sp3 exhibits additive and synergistic effects with Sp1 and also represses some Sp1 regulated genes. Sp4 was super activated with fingerless Sp1 and repressed by Sp3 [350-352]. Sp1 proteins regulate expression of several genes in combination with other transcription factors such as Oct-1, NF- κ B, E2F-1, GATA and SMAD3 [353-355]. Sp1 and E2F-1 synergistically interact on the dihydrofolatereductase (DHFR) and thymidine kinase promoters and other Sp proteins such as Sp2, Sp3 and Sp4 also interact with E2F-1 for regulation of specific genes such as murine thymidine kinase [349]. Sp1 also interacts with the basic transcription machinery including TATA binding protein (TBP), TBP associated factors (TAFs) and other basal TFs through glutamine rich activation domains A, B and C-terminal domains [356, 357]. Sp1 also requires CRSP (cofactor required for Sp1) for efficient activation of transcription and it mediates Sp1 activation of GC rich promoters by interacting with TATA box, initiator sequences and RNA polymerase pre initiation complex [358, 359].

Sp proteins play an important role in the regulation of key biological process such as cell proliferation, differentiation, survival and angiogenesis [339, 360, 361]. Even though the specific physiological functions of Sp proteins are not clear, some

gene knockout studies show that knockdown of Sp1, Sp3 and Sp4 results in embryolethality and severe abnormalities in the offspring including retarded development, reproductive abnormalities and defective tooth formation [362-365]. Thus the Sp gene family plays an important role in the normal development of organs and tissues. However expression of Sp1 and other Sp proteins is decreased in mature animals and decreases with age [366, 367].

Role of Sp proteins in cancer. Even though, Sp proteins are required for embryonic and postnatal development, there is emerging evidence that Sp protein expression plays a critical role in tumor development, growth and metastasis. Sp proteins such as Sp1, Sp3 and Sp4 are overexpressed in tumors compared to other tissues [368-372]. Lou and co workers [373] reported that carcinogen-induced transformation of fibroblasts increased expression of Sp1 by 8-18 fold and these transformed fibroblasts formed tumors in xenograft mouse models, while untransformed cells with low levels of Sp1 did not form tumors. Along with Sp1, other oncogenic genes such as VEGF are also highly expressed in gastric tumors and gastric tumor cells have elevated levels of nuclear Sp1 compared to adjacent non glandular/stromal cells. Sp1 is a poor prognostic factor for gastric cancer patients and high levels of Sp1 predicted decreased patient survival compared to patients with low-non detectable levels of Sp1. Moreover, there is positive correlation between Sp1 and VEGF suggesting that patients with high VEGF expression also have poor survival rates [374]. In addition, ribozyme dependent knockdown of Sp1 in transformed cells also decreases VEGF and induces apoptosis. Shi and coworkers [371] reported high expression of Sp1 and VEGF in pancreatic cancer cells and these results are consistent with studies indicating that Sp1 plays a critical role in VEGF regulation and knockdown of Sp1 along with Sp3 and Sp4 in pancreatic cancer cells

confirmed that Sp proteins regulate VEGF and its receptors [45, 46, 375]. Sp1 protein is also highly expressed in breast cancers and thyroid tumors [372, 376] and knockdown of Sp1 by small inhibitory RNAs inhibits G0/G1- S-phase progression in MCF-7 breast cancer cells [377]. Furthermore DNA-dependent protein kinases, such as Ku70 and Ku80 are highly upregulated in colon cancer tumors along with Sp1 and constitutive expression of these genes is regulated by interaction of Sp1 with their corresponding GC rich promoters resulting in tumor growth and metastasis [370]. In addition, Sp3 also plays an important role in cell proliferation and angiogenesis along with Sp1 by repressing p27, a CDK inhibitor in pancreatic cancer cells.

Mechanism of Sp protein action in cancer. Sp proteins regulate constitutive expression of several genes involved in multiple functions in both normal and cancer cells. Sp proteins bind to GC rich promoters and subsequent interactions with components of the basal transcription machinery activates gene transcription. Sp dependent activation of genes is a highly complex process which depends on several factors such as gene promoter, cell context and interaction with other nuclear factors. Sp1 and Sp3 are commonly used models to investigate the mechanism of Sp proteins in the activation of several genes.

Courey *et al.*, [378] first reported the synergistic interactions of Sp1 which forms homooligomeric complexes on GC rich promoters; this can be further attenuated by interaction of Sp1 with other nuclear factors on the same GC rich elements. Sp1 and Sp3 proteins bind to same GC promoters and work cooperatively or Sp3 inhibits Sp1 dependent transactivation and this depends on Sp1/Sp3 ratios for expression of some genes [379].

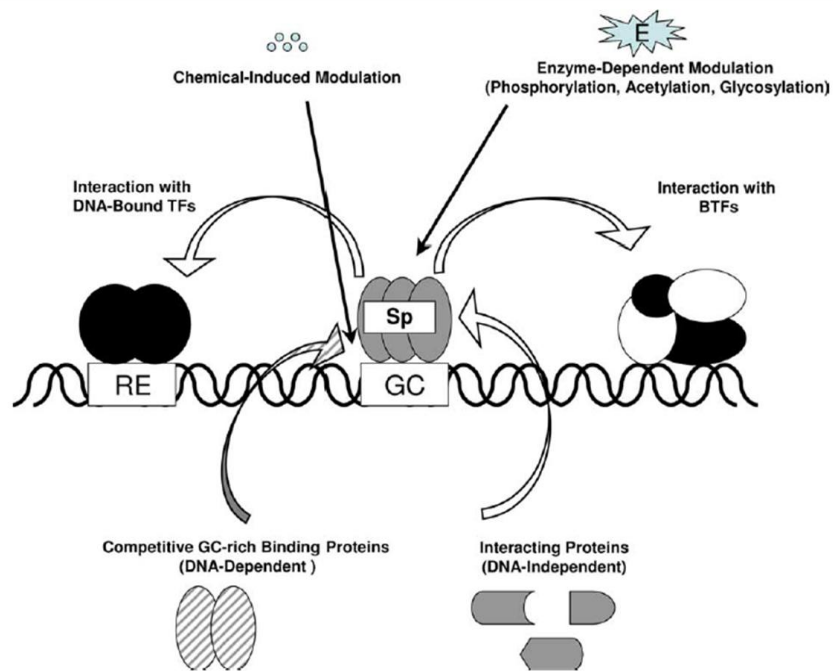

Fig.1.21. Sp dependent transactivation in cancer cells [369].

Sp1 and Sp3 cooperatively activate several genes by interacting with other TFs as previously indicated. In addition Sp1 also interacts with several nuclear receptors such as estrogen receptor (ER), progesterone receptor (PR), androgen receptor (AR), retinoic acid receptor (RAR), retinoic X receptor (RXR), peroxisome proliferator-activated receptor- γ (PPAR- γ), vitamin D receptor (VDR) and others [380]. All these interactions occur at the C-terminal domain C/D domain of Sp1 which is the major site for interaction with other proteins. Thus Sp1 and other Sp proteins also function as modulators of gene expression through interactions with different nuclear proteins and other DNA bound transcription factors (Fig. 1.21).

Several studies also have shown that modification of Sp proteins such as phosphorylation, glycosylation, and acetylation also plays an important role in the Sp-

dependent activation of some genes and this forms another layer of complexity in the function of Sp transcription factors (Fig. 1.21). In most prostate cancer cell lines, VEGF is regulated by PI3K and this is linked to increased phosphorylation of Sp1 and enhanced binding of the phosphoprotein to the GC rich promoter sequence [381], while MAPK dependent phosphorylation of Sp1 is critical for α 6-integrin gene expression [382]. In addition, cyclin dependent kinases also increase phosphorylation of Sp1 and Sp1-dependent responses/gene expression and this is also associated with increased DNA binding of Sp1 [383-385]. Acetylation of Sp1 and Sp3 also increases transactivation; for example, Sp3 inhibits TGFBR in late passage MCF-7 cells, while, acetylation of Sp3 induces transactivation of TGFBR [386, 387]. Similarly, topoisomerase II inhibitors activate SV40 promoter through acetylation of Sp1 and acetylation of these proteins is regulated by p300, which exhibits histone acetyltransferase activity [388]. In contrast serine threonine O-linkage with N-acetylglucosamine inhibits Sp1-dependent transactivation and is another factor that modifies Sp1 function [389].

Regulation of oncogenes by Sp proteins. Genes that regulate growth, proliferation, angiogenesis and cell cycle frequently contain GC rich elements in their proximal promoters, and their interaction with Sp and other TFs is important for their expression. Several reports have shown that Sp proteins regulate VEGF through proximal GC rich motifs and Sp1-mediated angiogenesis through induction of VEGF is cell context dependent [45, 371, 390]. Results of RNA interference studies showed that Sp proteins are involved in regulation of VEGF and this was due to binding of Sp1, Sp3 and Sp4 with the VEGF promoter. RNA interference studies have also shown that Sp1, Sp3 and Sp4 regulate genes involved in cell growth and cell cycle progression such as cyclins

and cyclin dependent kinases. For example transfection of pancreatic cancer cells with iSp3 results in upregulation of cyclin dependent kinase inhibitor p27 indicating that Sp3 enhances growth of pancreatic cancer cells by inhibiting p27 mRNA and protein expression through interaction with GC rich promoter elements. Sp proteins also regulate the expression of TGF- β /TGFBR signaling in cancer cells [391-393] and the TF's also regulate several genes associated with cell growth and cell cycle progression (CD1, E2F1, c-fos, TGF- α), purine/pyrimidine synthesis and metabolism [thymidylate synthase, adenosine deaminase, DNA polymerase α , carbamylphosphate synthase/aspartatecarbamyltransferase/dihydroorotase (CAD)], angiogenesis (VEGF) and anti-apoptosis (bcl-2) [341, 342, 390, 394-399]. Several other reports have also shown that Sp proteins regulate transcription of genes involved in the growth and metastasis of cancer cells and must be considered as prognostic factors for the disease and as potential targets of chemotherapy.

Strategies of Sp protein targeting in cancer cells. In some human cancers, Sp protein overexpression is a negative prognostic factor for survival and contributes towards proliferative and metastatic tumor phenotype. There are several possible strategies for targeting Sp proteins in cancer cells and these include drugs that inactivate GC-rich DNA motifs, oligonucleotides and peptide nucleic acid-DNA chimeras (Sp1 decoys) and chemicals that modulate Sp1 protein expression (Fig. 1.22).

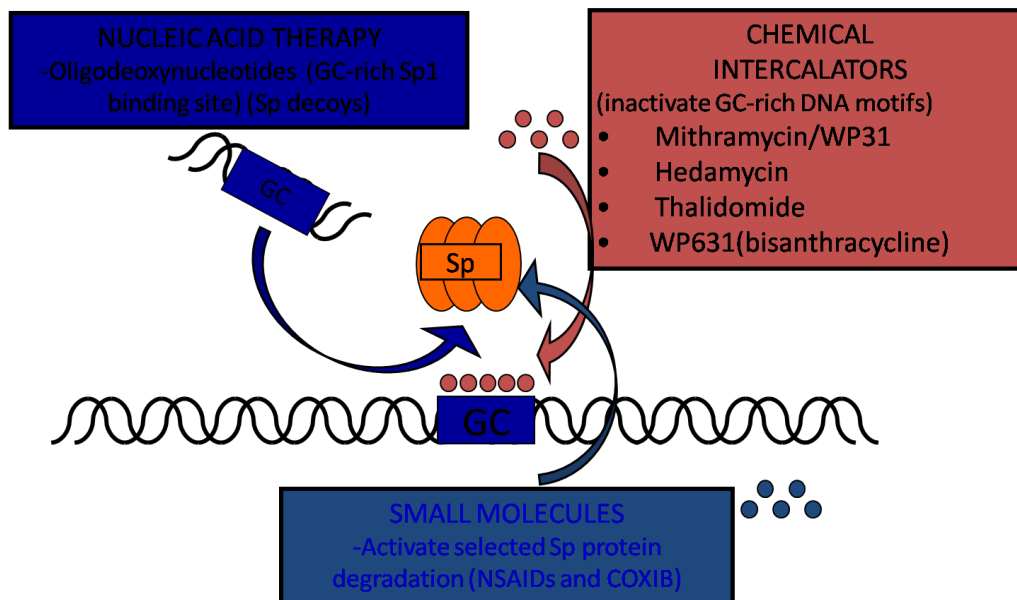

Fig. 1.22. Strategies for targeting Sp proteins in cancer cells.

Drugs such as mithramycin and hedamycin bind GC-rich motifs and decrease Sp1-DNA binding and Sp1-dependent gene expression [400, 401]. For example, TNF- α induction of thymidine kinase in colon cancer cells is due to enhanced Sp1-DNA binding and this was inhibited by mithramycin [401], while hedamycin inhibits survivin transcription by interacting with proximal GC-rich Sp1 binding site in the survivin gene promoter [402]. Double stranded GC rich oligonucleotides (Sp1 decoys) have been developed for inhibiting Sp1-dependent gene expression [403, 404] and TNF- α induced VEGF and TGF- β 1 gene/protein expression, cell proliferation and invasiveness is decreased by Sp1 decoys. Mutant Sp1 decoys are also being developed and there may be potential clinical applications for this technology for treatment of specific cancers [405, 406].

COX-2 inhibitors such as celecoxib are potent anticancer drugs because of their anti-angiogenic activity which has been linked to modulation of Sp1 transcription activity in pancreatic cancer cell lines [407-409] and this was due to decreased Sp1 protein phosphorylation and decreased P-Sp1/Sp1 ratios which binds the GC-rich VEGF promoter. This suggested that the anti-angiogenic activity of celecoxib in pancreatic cancer cells was due to targeted dephosphorylation of Sp1. Recent studies from our laboratory also investigated the anti cancer activity of non steroidal anti-inflammatory drugs (NSAIDs) and COX-2 inhibitors in pancreatic, colon and other cancer cell lines. The growth inhibitory effect of celecoxib, nimesulide and NS-398 in SW480 colon cancer cells was due to downregulation of Sp1 and Sp4 but not Sp3 proteins. It was further shown that down regulation of Sp1 and Sp4 was COX independent and due to activation of proteasomes which specifically targeted degradation of Sp1 and Sp4 in colon cancer cells [410]. These results indicated an opportunity for development of small molecule drugs that target Sp TF's and Sp-regulated genes that are important for cancer cell growth arrest, inhibition of angiogenesis and metastasis for several cancers.

In conclusion, Sp transcription factors play an important role in tumor development, growth and metastasis. The complexity of Sp-regulated gene expression depends on domain specific interaction of Sp1 with other transcription & nuclear factors, and also chemical and enzyme induced modifications. This complexity may be highly advantageous for treating some cancers since combined targeting of different pathways that modulate Sp protein expression and activity may enhance the selectivity and efficacy of this type of therapy.

NSAIDs AS ANTI-CANCER AGENTS

NSAIDs are a chemically diverse group of drugs that are available over the counter or by prescription world-wide. These drugs are commonly used to treat a variety of acute and chronic inflammatory conditions including pain, fever and arthritis. Fig. 1.23 represents the chemical structure of aspirin, the most widely used NSAID which was discovered over 150 years ago.

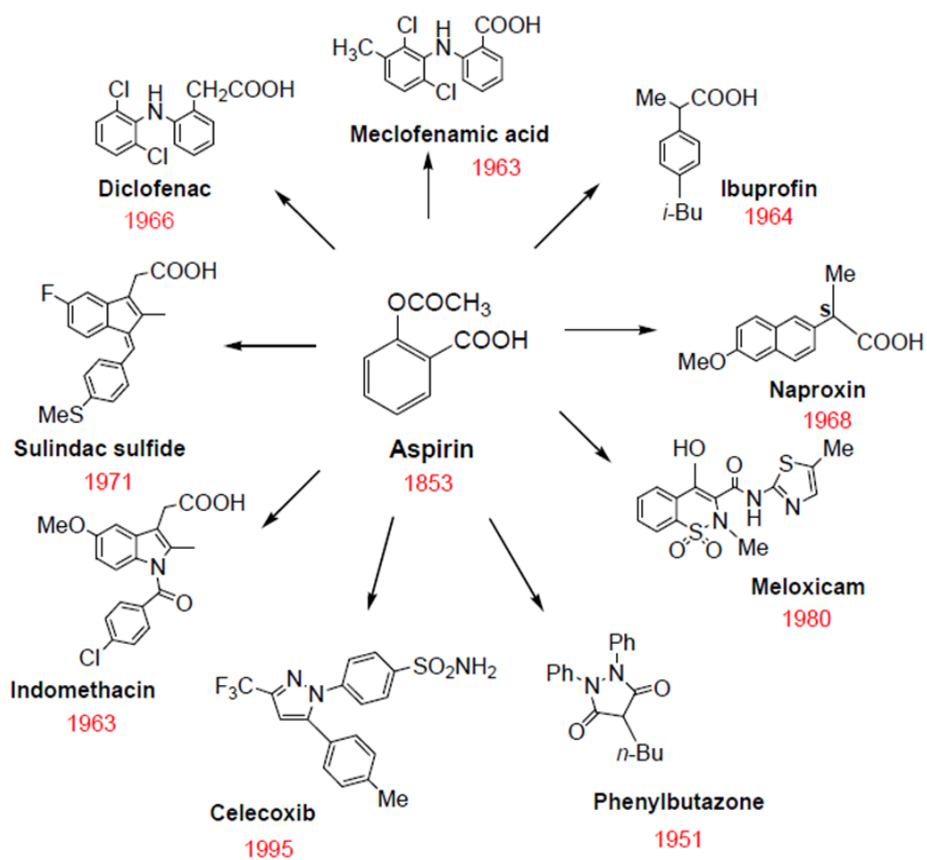

Figure 1.23. Chemical structures of commonly used NSAIDs.

The pharmacological basis for the anti-inflammatory activity of NSAIDs is due to inhibition of COX enzymes which prevents the conversion of arachidonic acid to

prostaglandin H₂, a precursor of prostaglandins, prostacyclins and thromboxanes (Fig 1. 24) [411].

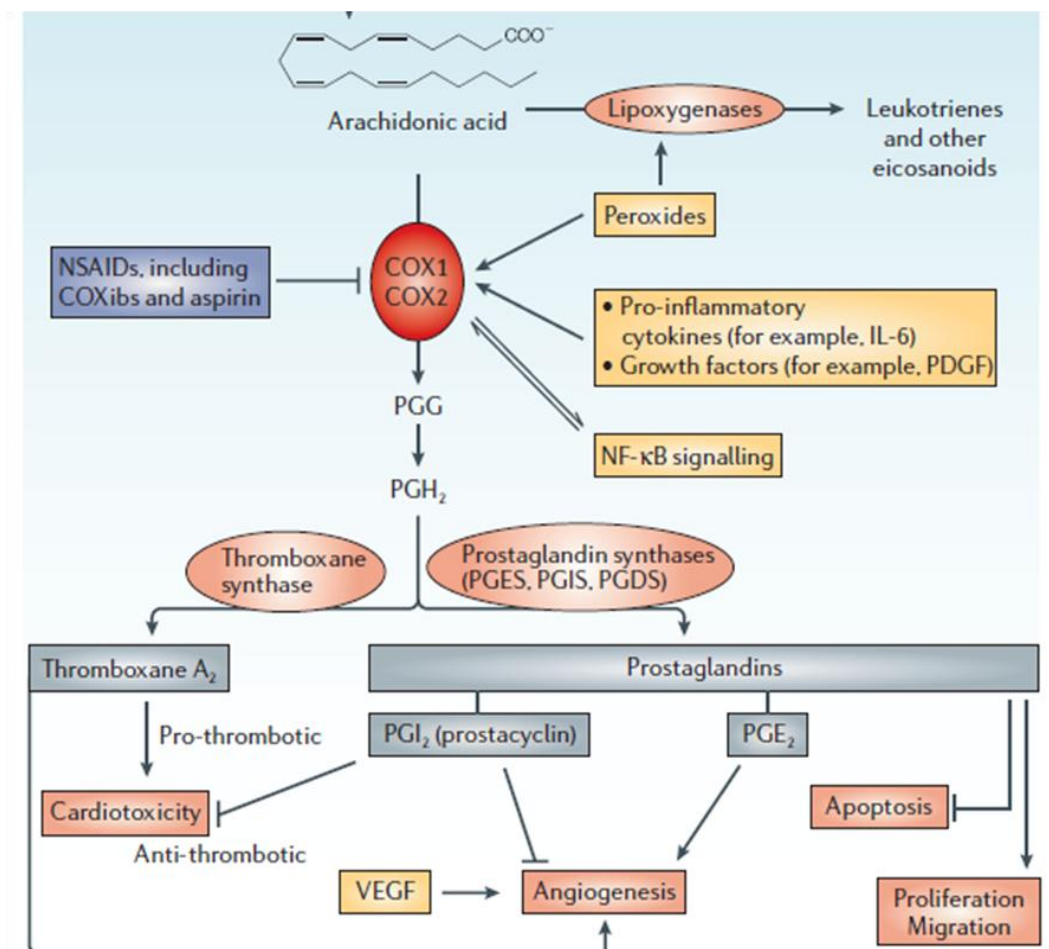

Fig.1.24. NSAIDs, COX inhibition and prostaglandins [412].

COX is a key regulatory enzyme in prostaglandin biosynthesis and is responsible for induction of inflammation [413]. COX-1 is a constitutive enzyme required for the regulation of prostaglandin biosynthesis and prostaglandin-dependent effects on blood flow & tissue integrity. COX-2 is an inducible enzyme expressed in inflammatory cells & cancer cells and hence, considered to be an ideal target for inhibition of

inflammation and tumorigenesis. This property makes NSAIDs valuable for treatment of diseases associated with inflammation and cancer. Several studies have shown increased levels of COX enzymes & prostaglandins in various tumors suggesting that inflammation plays an important role in tumorigenesis and that the suppression of prostaglandin synthesis is essential for activity of NSAIDs in disease prevention [194, 197, 414, 415]. However many responses induced by NSAIDs cannot be explained by COX inhibition indicating that COX-dependent and independent mechanisms play an important role in the biological and anticancer activity of NSAIDs. Several clinical, epidemiological & experimental studies have shown that aspirin and other NSAIDs are promising anti-cancer agents and prolonged continuous use of NSAIDs decreases the risk of cancer of the colon and other gastrointestinal organs as well as breast, prostate, lung and skin cancers [416-422]. Recent studies and reviews have assessed the association of NSAIDs with the reduced risk of gastric cancer and suggested that continuous long-term administration of aspirin results in a significant dose dependent reduction of gastric and colon cancers and it was protective in all age groups of men and women [423]. Continuous use of NSAIDs in cancers seem to have protective effect, while infrequent use is not associated with reduced risk for both colorectal cancers and adenomas [419, 424]. NSAIDs reduce precancerous adenomas in patients with familial or sporadic adenomatous polyposis and the non-selective COX inhibitor sulindac and the COX-2 selective inhibitor celecoxib prevent formation and regression of adenomas in patients with familial polyposis [425-428]. NSAIDs also exhibit anti-carcinogenic effects in experimental animal models such as chemically induced gastric tumors in mice which can be decreased by aspirin, sulindac, indomethacin and ibuprofen [429-432]. NSAIDs also exhibit anti-tumorigenic activity in xenograft mouse models and

inhibit growth of transplanted tumors and carcinogen induced skin tumors in mice & rats [429-432]. Several NSAIDs also decrease polyp multiplicity, tumor incidence and colon cancer cell growth (Table. 1.10).

Table. 1.10. Effects of COX-2 selective inhibitors in animal models of colorectal cancers

(* Non-selective NSAID inhibitors, ** Selective COX-2 inhibitors) [433].

NSAID treatment	Outcome
<i>Apc</i>^{min} mouse	
Sulindac*	↓ polyp multiplicity
Piroxicam*	↓ polyp multiplicity
Celecoxib**	↓ polyp multiplicity
<i>Apc</i> Δ⁷¹⁶ mouse	
Rofecoxib**	↓ polyp multiplicity
Azoxymethane-treated rat	
Celecoxib**	↓ tumor incidence
	↓ multiplicity
NS-398**	↓ tumor incidence
	↓ multiplicity
Nimesulide**	↓ tumor incidence
	↓ multiplicity
Aspirin*	↓ tumor incidence
	↓ multiplicity
Nude mouse xenograft	
SC-58125**	↓ colon carcinoma cell growth
Celecoxib**	↓ colon carcinoma cell growth
Meloxicam*	↓ colon carcinoma cell growth

Both experimental and epidemiological studies show that the anti-tumorogenic effects of NSAIDs are reversible and tumor recurrence increases shortly after discontinuous use of NSAIDs [434]. Aspirin and several other NSAIDs also induce apoptosis & inhibit proliferation of various cancer cell lines [418, 435, 436] and it has

been reported that both COX-2 dependent and independent mechanisms are involved in NSAID induced apoptosis [418, 435].

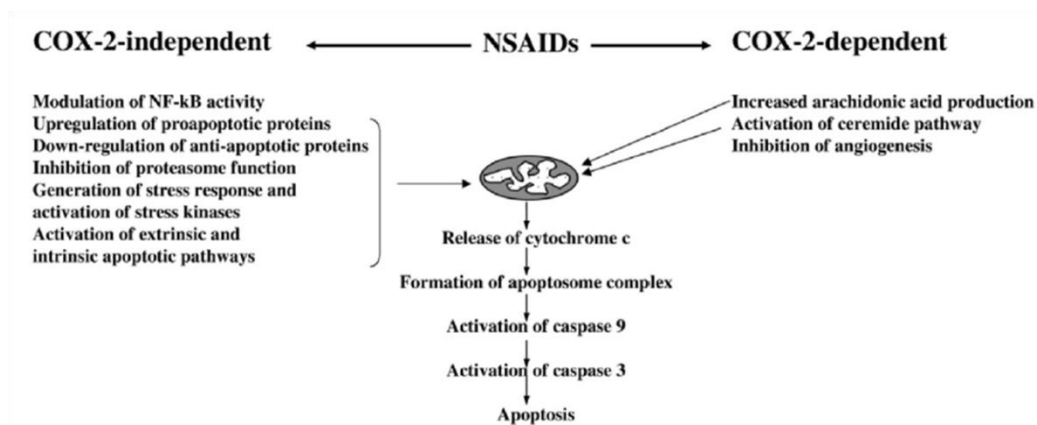

Fig. 1. 25. COX2-depenedent and –independent mechanisms of NSAID induced apoptosis [437].

Inhibition of cancer: COX-2-dependent mechanisms. Constitutive expression of COX-1 in mammalian tissues is responsible for homeostasis and maintenance of gastrointestinal mucosal integrity [438]. In contrary, COX-2 is largely induced during inflammation and several studies show overproduction of COX-2 and PGE2 in gastric & colon tumors, suggesting that overexpression of COX-2 plays a role in gastric cancers [439-442]; and it was hypothesized that anti-carcinogenic activity of NSAIDs was due to inhibition of COX-2 [216]. Overexpression of COX-2 contributes to carcinogenesis by increasing cell proliferation, inhibiting apoptosis, and enhancing angiogenesis and these effects are thought to be mediated through induction of PGE2 [418, 435, 440]. COX2 overexpression also increases cellular levels of bcl-2 and this results in the resistance to apoptosis of premalignant cells [443], whereas induction of apoptosis by COX-2

inhibition is not well understood. Other studies show that decreased cellular PGE₂ and increased arachidonic acid levels might be involved in induction of apoptosis and inhibition of cell proliferation (Fig. 1.25) [436]. Increased levels of arachidonic acid can alter mitochondrial membrane potential & permeability and releases of cytochrome C, leading to apoptosis [444, 445] and arachidonic acid also increases production of ceramide, a potent inducer of apoptosis (Fig. 1.25) [446]. COX-2 is also involved in the promotion of angiogenesis in several experimental systems and is critical for progression of many cancers [44, 447]. Importantly, NSAIDs inhibit both COX-1 and COX-2 to varying degrees; the therapeutic effects of traditional NSAIDs are due to inhibition of COX-2 and adverse effects such as gastrointestinal toxicity are due to inhibition of COX-1 activity. This has led to the development of selective COX-2 inhibitors, which are relatively less toxic than conventional NSAIDs [438, 439].

Apoptosis caused by NSAIDs is not fully explained by COX inhibition, because anti-proliferative and apoptotic effects were also observed in cell lines irrespective of their COX levels [448]. Moreover, NSAIDs also inhibit growth of colon cancer cell lines that are negative for COX enzymes and mouse embryo fibroblasts that are null for both COX enzymes [449, 450]. Interestingly, the dose of NSAIDs required to give anti-carcinogenic effects is much higher than required for inhibition of inflammation (Table. 1.11). The difference in the clinical activities of low and high dose of aspirin has led to the speculation that not only COX inhibition but also COX independent effects are responsible for the benefits of aspirin [451].

Table. 1.11. Tumor cell growth and COX inhibitory activity of different NSAIDs.

NSAID	Growth IC50 (μM)	COX-1 IC50 (μM)	COX-2 IC50 (μM)	Serum levels (μM)
Celecoxib	50	>30	2.25	2
Sulindac sulfide	60	1.02	10.4	15
Diclofenac	160	0.14	0.05	6
Indomethacin	180	0.16	0.46	1.4
Piroxicam	900	0.76	8.9	17
Ibuprofen	975	4.75	>30	40
Flurbiprofen	1800	0.44	6.42	53
Aspirin	5000	4.5	13.9	10

COX-2-independent mechanisms of NSAIDs. At higher concentrations, NSAIDs activate a number of COX-1 and COX-2-independent pathways including downregulation of NF- κ B activity [452-454], changes in expression of pro- and anti-apoptotic proteins [455-457], activation of extrinsic and intrinsic apoptosis pathways [458-461], inhibition of proteasome function [462, 463], cell cycle arrest [462-466], and activation of stress kinases and generation of the stress response (Fig. 1.26) [467-471]. For example, Sulindac and other NSAIDs induce apoptosis in colon cancer cells and this process is mediated by 15-lipoxygenase 1 [472-474]. NSAIDs also activate peroxisome proliferator activated receptor (PPAR) subtypes- α , γ and δ and PPAR δ interacts with APC/ β -catenin signaling in colorectal cancer [219, 475, 476]. In addition NSAIDs also target multidrug resistance protein 4 (MRP4), which modulates release of prostaglandins from cells and this function is inhibited by NSAIDs (Fig. 1.26) [477].

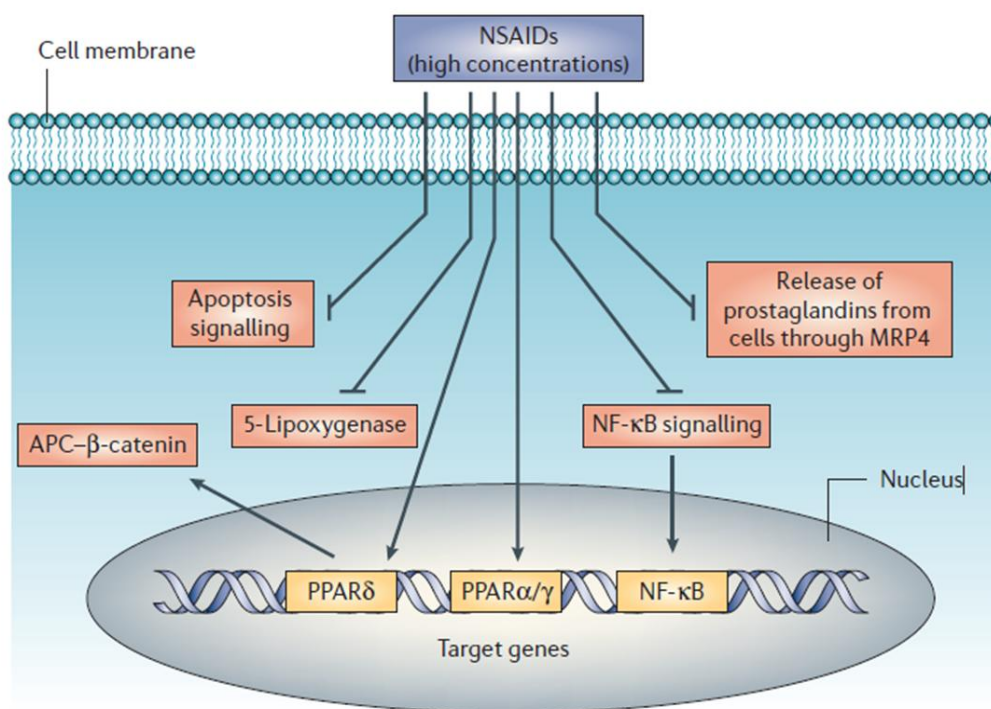

Fig. 1.26. NSAIDs and non-COX targets [412].

Some of these mechanisms are also regulated through COX-2 dependent pathways, since NSAIDs induced cell death, suppression of NF-κB activation and inhibition of expression of COX-2 is dependent on cell context and dose [478, 479]. Indomethacin, ibuprofen and sulindac are more potent inducers of apoptosis compared to aspirin in a variety of cancer cells such as pancreatic and lung cancer cells [478, 479].

Downregulation of NF-κB pathway. Activation of NF-κB stimulates different pathways that promote cell death and cell survival [480-482]. NF-κB activity is elevated in several cancers, especially advanced cancers that have been treated previously; and high NF-κB activity plays a critical role in chemo-resistance of many cancers [480, 483]. Several NSAIDs including aspirin induce apoptosis through inhibition of NF-κB activity and also inhibit TNF-α-induced activation of NF-κB and sensitizes gastric cell lines to TNF-α.

[452, 453, 484]. NSAIDs also inhibit I- κ B kinase β , an enzyme responsible for activation of NF- κ B through phosphorylation and subsequent proteasomal degradation of I- κ B- α [453]. Other reports have shown that aspirin-induced apoptosis is through enhanced degradation of I κ B- α and increased NF- κ B activity [485, 486]. Therefore the effect of NSAIDs on NF- κ B activity is contradictory and also dependent on cell context and dose. NSAIDs also inhibit AP-1 activity and this is related to the induction of apoptotic signals [470].

Activation of apoptotic pathway. Aspirin and other NSAIDs induce apoptosis through both intrinsic and extrinsic pathways. In some cells NSAIDs alter mitochondrial membrane permeability and release cytochrome c and activate caspase 8 & 9, thus leading to apoptosis [455, 458-461]. The release of cytochrome c from mitochondria is considered as a central event in apoptosis and it is an early event in NSAID-induced apoptosis [487] [459, 462, 487]. Cytochrome c binds with apoptotic protease activating factor-1 (apaf-1) and subsequent activation of caspase-9 & caspase-3. In human cancer (gastric, ovarian) cells, aspirin-induced apoptosis is partially blocked by caspase inhibitors and overexpression of anti-apoptotic bcl-2 [455, 459, 460]. Knockout of apaf-1 in HeLa cells resulted in resistance to aspirin-induced apoptosis [459]. In addition to caspase 9 and caspase 3, caspase 8 also plays a role in aspirin induced apoptosis by direct activation of downstream caspases or by cleaving the BH3 interacting domain death agonist (Bid); tBid then translocates to mitochondria and induces the release of cytochrome c. NSAIDs also mediate apoptosis through upregulation of pro-apoptotic and downregulation of anti-apoptotic proteins [455-457]. NSAIDs downregulate bcl-2 expression and induce the expression of bcl-2 associated X protein (Bax), bcl-2 antagonist of cell death (Bad) and p53 [455-457, 462]. For example, COX-2-selective

inhibitors SC-58125 and NS-398 sensitize colon and prostate cancer cells to apoptosis by downregulating bcl-2 [488], while aspirin and indomethacin induced apoptosis by upregulation of Bax & Bak and activation of caspase 3 [457]. Bax translocates from the cytosol to the outer mitochondrial membrane to facilitate release of cytochrome c through formation of pores [489]. Release of cytochrome c from mitochondria is also due to downregulation of bcl-2, arachidonic acid and ceramide, which are increased due to inhibition of COX-2. Thus, the mitochondria is a common target of both COX-2-dependent and -independent apoptotic pathways induced by NSAIDs. NSAIDs also induce apoptosis by downregulation of protein kinase C- β 1 (PKC- β 1) [490], a survival mediator.

Inhibition of proteasome function and cell cycle arrest. NSAIDs induce cell cycle arrest and cause apoptosis through inhibition of proteasome function [462-466]. The ubiquitin proteasome system (UPS) is a major extra lysosomal pathway responsible for intracellular protein degradation in eukaryotes and this pathway is involved in the degradation of several important regulatory proteins associated with regulation of the cell cycle and differentiation [491, 492]. The target proteins are conjugated with ubiquitin through covalent attachment and the tagged protein is recognized and degraded by the proteasomal machinery. The UPS is involved in degradation of many short-lived proteins that are required for cell survival and modulation of this pathway can promote cell context-dependent cell death [493-495]. Some reports show that proteasome inhibition also generates stress responses and induces various heat-shock proteins which increase tolerance to stressful conditions [496]. Proteasome inhibitors also inhibit NF- κ B activity, induce oxidative and endoplasmic (ER) stress, and activate various stress kinases. Treatment of different cell lines (neuro-2a, COS-1, and HeLa) with

aspirin decreases proteasome function and increases accumulation of ubiquitinated proteins and is accompanied by apoptosis [462]. Aspirin and other NSAIDs increase intracellular accumulation of various proteasomal substrates, such as Bax, I κ B- α , p53, p21^{waf1/Cip1} and p27^{kip1}, which are pro-apoptotic [455, 457, 462, 464, 465] and also increase accumulation of p27^{kip1} or p21^{waf1/Cip1} which cause cell cycle arrest at the G1/S phase and induce apoptosis. The mechanisms of proteasome inhibition by aspirin and other NSAIDs is not known, however NSAIDs-induced proteasomal dysfunction explains many of the growth inhibitory and proapoptotic effects of NSAIDs.

Induction of stress response. NSAIDs also induce oxidative & ER stress, and these stress responses are involved in the initiation of apoptotic signals [467-469]. ER stress response is induced by accumulation of unfolded proteins in the ER in which activating transcription factor (ATF) 4- and 6-dependent activate C/EBP homologous transcription factor (CHOP). ER stress also activates apoptosis signal regulating kinase 1 (ASK1), and activated ASK1 induces apoptosis through cJun N-terminal kinase (JNK) [497]. ER stress also activates caspase-12 and activated caspase-12 further activates caspase-9 and -3 [497]. Indomethacin induces both glucose-regulated protein-78 and CHOP [469] and also activates ATF6, ATF4, X box binding protein-1, ASK1 and JNK [469-471, 498]. NSAID-induced apoptosis is also initiated by generation of oxidative stress, through activation of the intrinsic apoptosis pathway involving mitochondria [467, 468]. NSAID induced ER or oxidative stress most likely depends on the concentrations and the types of drugs used [499]. Nitric oxide-donating NSAIDs, which are safer than their NSAIDs counterpart, are more potent inducers of oxidative stress and apoptosis than NSAIDs [499].

In conclusion, aspirin and other NSAIDs induce COX-2-dependent or – independent pathways in cancer cells and further understanding of the mechanisms of NSAID-induced apoptosis will greatly facilitate the design of more potent and safer drugs for the treatment of gastric, colon and other cancers. One of the major problems with NSAIDs is that they require higher doses to produce their anti-carcinogenic effects and to induce apoptosis. Selective COX-2 inhibitors or nitric oxide-donating NSAIDs with minimum gastrointestinal side effects are also promising anti-cancer drugs that can also be combined with drugs targeting multiple oncogenic pathways to enhance their clinical efficacy. Examples of this combination therapy include combining selective COX-2 inhibitors with EGF receptor inhibitors and/or protein kinase A inhibitors [500], coupling inhibitors of COX-2 with compounds that block matrix metalloproteinases [501], combining specific COX-2 inhibitors with herceptin [502], or simply adding COX-2 inhibitors to standard colon cancer chemotherapy regimens.

Aspirin and human cancer - Epidemiological studies. The first epidemiological evidence that aspirin acts as a chemoprevention agent came from a case control study, in which aspirin use was associated with a significantly lower risk of colorectal cancer even after adjustment for other risk factors [503]. In 2005, Bosetti *et al.*, [504] reviewed all case–control and cohort reports (~100 studies) regarding the chemopreventive activity of aspirin; the pooled relative risk (RR) for developing colorectal cancer was 0.71 (95% CI: 0.67–0.75), even though there was significant heterogeneity between trials and study designs. There was limited evidence that aspirin prevented cancers of the esophagus (RR 0.72, 95% CI: 0.62–0.84), stomach (RR 0.84, 95% CI: 0.76–0.93), breast (RR 0.91, 95% CI: 0.88–0.95) and lung (RR 0.94, 95% CI: 0.89–1.00) [504]. Recently, two large cohort studies have highlighted that the magnitude of the response

depends on both the dose and duration of aspirin use, with the maximum decrease in colorectal cancer incidence seen when > 14 aspirin tablets (325 mg) were taken per week for 6–10 years [505, 506].

Two recent non-randomised studies have examined the use of aspirin after a diagnosis of cancer as a chemotherapeutic drug. Regular use of aspirin after diagnosis of colorectal cancer decreased colorectal cancer-specific mortality (HR 0.71, 95% CI: 0.53–0.95) and overall mortality (HR 0.79, 95% CI: 0.65–0.97) in aspirin users when compared to non-users [434, 505, 506]. Notably, patients with primary tumors overexpressing COX-2 had the most benefit with an HR of 0.39 (95% CI: 0.20–0.76) for colorectal cancer-specific mortality compared with an HR of 1.22 (95% CI: 0.36–4.18) for those whose primary tumors had weak or absent COX-2 expression. In addition, those who had taken aspirin before diagnosis did not seem to benefit (HR 0.89, 95% CI: 0.59–1.35) compared with those with no previous use (HR 0.53, 95% CI: 0.51–0.92) [434]. Similar results have been reported for breast cancer, with aspirin use after breast cancer diagnosis associated with decreased distant recurrence and breast cancer mortality [507]. Three small randomised-controlled trials have assessed the effects of aspirin in combination with traditional chemotherapy. Three hundred small cell lung cancer patients were assigned to take 1g of aspirin per day for 18 months or no aspirin in addition to their chemotherapy [508] and it was reported that there was no significant difference in survival between the groups and aspirin was well tolerated. Another trial found no evidence of a survival benefit when 176 patients with advanced renal cell carcinoma received interferon- α with or without aspirin 2400 mg daily [509]. Another small trial of 66 patients evaluated 1200 mg of aspirin daily compared with placebo as

adjuvant treatment for Duke's B2 and C colorectal cancer (HR for survival 0.65, 95% CI: 0.02–18.06, P¼0.90) [510].

In conclusion, aspirin continues to be evaluated *in vitro* and in pre-clinical models as to the mechanisms of action as anti-neoplastic agent. Recent evidence from randomized trials shows a decrease in cancer incidence with long-term follow-up and colorectal & breast cancer studies show that aspirin use post-diagnosis increases cancer survival and decreases the time to recurrence. The development of new combination therapies that include aspirin should provide effective, low cost cancer treatment options.

Tolfenamic acid (TA) as anticancer agent. TA is a widely used NSAID for treatment of migraines, headaches and alcohol induced hangovers [511]. It is a potent, well tolerated NSAID with relatively few side effects and a high therapeutic index [512]. It has antipyretic and analgesic properties as evidenced in several animal models and also shows promising results for treatment of osteoarthritis and rheumatoid arthritis [513, 514]. Fig. 1.27 represents the structure of TA.

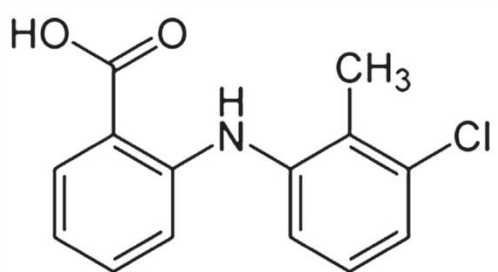

Fig. 1.27. The structure of TA [515].

The commercial names for TA are Clotam Rapid and Tufnil for use in humans (not in the United States) and Tolfedine for veterinary use. The systematic (IUPAC)

name for TA is “2-[(3-chloro-2-methylphenyl)amino]benzoic acid” and it belongs to the “fenamates” class of NSAIDs [516, 517]. NSAIDs are known to cause side-effects, which include gastrointestinal bleeding and ulceration and high oral doses of TA exhibits a decreased incidence of these. In rare cases, other reported side effects such as fatigue, headache, vertigo, tremors, euphoria, and anemia may occur. In one study conducted on wistar rats, TA caused only low gastro-ulcerogenicity when compared with 10 other NSAIDs including ketoprofen, indomethacin, and naproxen [512].

Recently, several reports have shown the efficacy of this drug for cancer chemotherapy [375, 518]. Studies from our laboratory identified TA as a novel anti-cancer agent in pancreatic, breast, esophageal and lung cancer models [519, 520] [518, 521]. The anti-cancer activity of TA is COX-independent and related to the degradation of Sp transcription factors. TA inhibits pancreatic cancer cell growth and tumor growth through induction of proteasome-dependent degradation of Sp transcription factors [45, 375, 518]. Recent evidence shows that TA induces apoptosis in colon cancer cells and also inhibits metastasis & tumorigenesis in pancreatic cancer models [375, 522, 523]. TA decreases the expression of angiogenic genes such as VEGF and VEGF receptors, which are mediated through downregulation of Sp transcription factors. The anti-angiogenic activity of TA is associated with the inhibition of liver metastasis in an orthotropic model of pancreatic cancer [518]. TA also inhibits lung, esophageal, breast and ovarian cancer cell growth and with the exception of breast cancer cells, TA also induced downregulation of Sp1, Sp3, Sp4 and Sp-regulated genes [516, 519-522, 524].

However, the molecular basis for the induction of apoptosis and scope of its action in colorectal cancer has not been reported and will be investigated as part of my thesis research.

NO-NSAIDs AND CANCER

Design of pharmacological agents includes modification of known compounds in order to optimize their pharmacological properties, such as safety and efficacy. Nitric oxide-donating nonsteroidal anti-inflammatory drugs (NO-NSAIDs) represent an emerging class of drugs and their design was based on the known properties of NSAIDs and the newly discovered NO, a molecule that plays an important role in the cardiovascular system and in human physiology. It was expected that, NO-NSAIDs would exhibit properties of both NSAIDs and NO groups. Since release of NO group would mimic the effects of antihypertensive agents and prostaglandin analogs. NO-donating compounds are also promising for treatment of other diseases, including cardiovascular diseases, asthma, hypoxic–ischemic brain injury, glaucoma, and alzheimer's disease because of their antioxidant activity [525-529].

NO-NSAIDs consist of a conventional NSAID to which an NO-releasing moiety is attached covalently, often via a spacer molecule (Fig. 1.28).

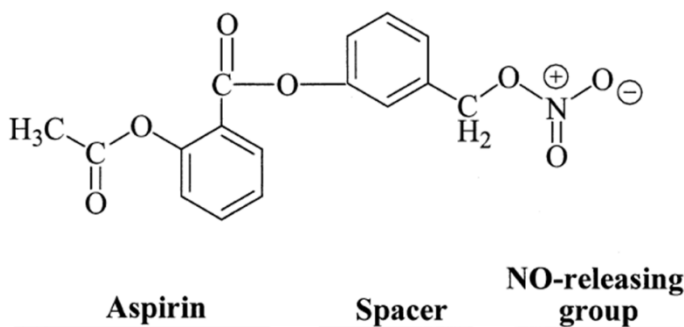

Fig. 1.28. The chemical structure of NO-aspirin. The aspirin derivative designated NCX 4016 [2-(acetyloxy)benzoic acid 3-(nitrooxymethyl)phenyl ester] is shown with its three structural components highlighted. The spacer molecule links traditional aspirin to -NO₂, which can release NO [530].

Del Soldato *et al.* [531] first synthesized NO-NSAIDs and a large number of NO-NSAIDs can be generated by varying the spacer molecules (Fig. 1.29), which can include aliphatic and aromatic molecules and the latter were more effective as spacers. Positional isomerism also influences the pharmacological efficiency of NO-ASA in colon cancer cells [530].

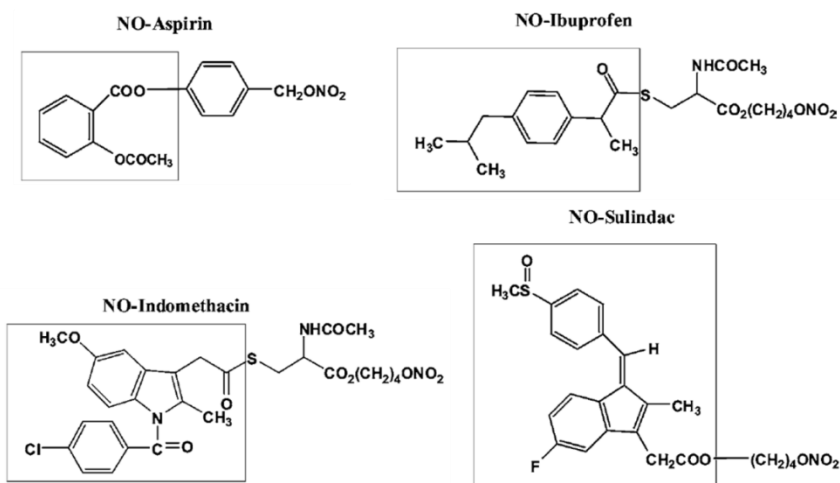

Fig.1.29. The structure of representative NO-NSAIDs. NO-NSAIDs consist of a conventional NSAID, the spacer molecule and the NO-releasing moiety (-ONO₂). The conventional NSAID is in the boxed area [532].

The rationale for the initial synthesis of NO-NSAIDs was based on the fact that NSAIDs damage the gastrointestinal mucosa by inhibiting the synthesis of cytoprotective prostaglandins [7], whereas the action of NO on this mucosa is similar to that of prostaglandins. Several *in vivo* studies showed that both prostaglandins and NO modulate mucosal blood flow, mucus release, mucosal injury repair, inhibit neutrophil adherence and activation, and of suppress mast cell degranulation [533, 534]. Thus release of NO by NO-NSAID provides locally generated NO and thereby protects from

NSAID-induced mucosal damage and this has been demonstrated in several animal and some human studies (Fig. 1.30) [535, 536]. For example, NO-donating aspirin maintains cyclooxygenase-1 and platelet inhibitory activity with minimal gastrointestinal damage. NMI-1182 and AZD3582 are NO-derivatives of naproxen that exhibit inhibition of COX activity similar to that naproxen, but cause significantly fewer gastric lesions than naproxen. The safety of NO-ASA was established in randomized studies conducted on 40 healthy subjects who were treated with NO-ASA or ASA or placebo for a week. Toxicity was determined using endoscopic injury scores which were lower for NO-ASA compared to that of ASA [536]. NO-NSAIDs exhibit a significantly higher cytostatic and cytotoxic activity than that of the parent NSAID in different experimental *in vitro* and *in vivo* cancer models [537-549].

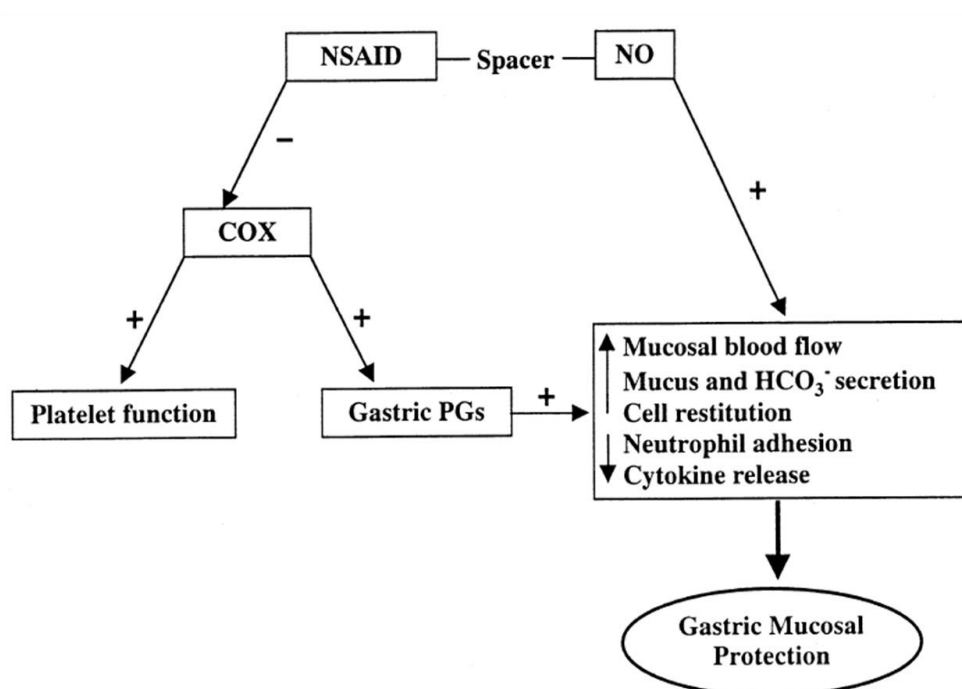

Fig. 1.30. Mechanism of gastric cytoprotection by NO-NSAIDs. While the NSAID moiety inhibits gastric PG production, the NO released from the NO-NSAID compensates for the loss of the PG synthesis. This mechanism is thought to account for the protection of gastric mucosa by NO-NSAIDs [530].

The hypothesized release of the cytoprotective NO group from NO-NSAIDs within the stomach is not accurate, since NO-ASA traverses the stomach intact, thus ruling out this mechanism, at least in the case of NO-ASA [550, 551]. An alternative explanation is that NO is released beyond the upper GI tract and can reach the gastric mucosa via the circulation; however this route of NO delivery to mucosa is unknown; even though elevated NO levels in the circulation have been observed following administration of NO-NSAIDs [551].

The chemotherapeutic properties of NO-NSAIDs such as NO-ASA, NO-sulindac and NO-ibuprofen have been reported in colon cancer cells; these compounds decreased growth of cultured HT-29 human colon adenocarcinoma cells more effectively compared to that of their related NSAIDs [548] and this was subsequently shown in several cancer cell lines [543, 545, 547, 552]. NO-NSAIDs inhibited cell proliferation, induced apoptosis and DNA degradation and caused a G₀/G₁ to S phase block in cell cycle progression [530]. The anticancer activity NO-NSAIDs was also observed in Min mice and in azoxymethane induced colon cancer. For example, NO-ASP decreased incidence, multiplicity and size of tumor in Min mice and in azoxymethane induced colon tumors [538, 540, 542, 553] and NCX-4016 (NO-ASA) decreased the number of aberrant cryptic foci in the colon by 85%, where as only a 64% was observed for aspirin [552].

The anticancer activity of NO-NSAIDs has been observed not only in the colon cancer models but also in animal models for pancreatic, ovarian and bladder cancer [541, 552, 554, 555]. Other reports show that positional isomers of NO-NSAIDs also influence their anticancer activity. For example, the IC₅₀ for growth inhibition of HT-29 colon cancer cells differed between p-NO-ASP (12 μ M) and m-NO-ASP (230 μ M); *meta*

NO-ASA (3000 ppm) decreased pancreatic tumor growth and incidence (89.5%) where as ASA (3000 ppm) was not active [556]. NO-ASA also inhibited growth of BxPC-3 human pancreatic cancer cells by increasing intracellular ROS, activation of MAPKs and induction of p21^{cip-1} resulting in suppression of cyclin D1 and growth inhibition [554]. NCX-4016 inhibited EGFR and STAT3 signaling, modulated Bcl-2 expression, induced apoptosis and inhibited cell cycle progression in cisplatin-resistant human ovarian cancer cells & xenografts [555]. A short 6 hour exposure to NCX-4040, a NO-ASP induced apoptosis due to caspase activation and mitochondrial membrane protein depolarization in HT1376 and MCR bladder cancer cell lines [541].

Table. 1.12. Growth inhibitory IC₅₀ values of NSAIDs and NO-NSAIDs in colon cancer cells [552].

Compound	IC ₅₀ (μM)	
	HT-29	HCT-15
Aspirin	3500 ± 300	3000 ± 250
NO-Aspirin	5 ± 2	3 ± 1
Ratio	689 ± 115	1083 ± 114
Sulindac	682 ± 35	487 ± 50
NO-sulindac	33 ± 5	35 ± 4
Ratio	21 ± 1	14 ± 0.7
Indomethacin	580 ± 50	436 ± 40
NO-indomethacin	35 ± 4	25 ± 3
Ratio	17 ± 0.7	18 ± 0.8
Salicylic acid	>1000	>1000
NO-salicylic acid	143 ± 28	112 ± 18
Ratio	>7	>9
Ibuprofen	>1000	>1000
NO-Ibuprofen	48 ± 15	57 ± 20
Ratio	>21	>18
Flurbiprofen	782 ± 35	450 ± 50
NO-flurbiprofen	98 ± 10	285 ± 75
Ratio	9 ± 0.4	1.7 ± 0.2

Several NO-NSAIDs including NO-ASA, NO-salicylic acid, NO-indomethacin, NO-sulindac, NO-ibuprofen and NO-flurbiprofen were more potent than their parent NSAIDs (Table.1.12) as inhibitors of HT-29 and HCT-15 colon cancer cell growth and the IC50s for these NO-NSAIDs were between 7-and -689 fold and 1.7- to 1083 fold lower than their corresponding NSAIDs in these cells respectively [552]. The activity NO-NSAIDs was COX-independent since HT-29 cells express COX enzymes whereas HCT-15 cells do not. NO-NSAIDs also cause morphological changes which include nuclear condensation, extensive vacuolization of cytoplasm, loss of cell membrane integrity, loss of volume and texture of the nucleus indicative of apoptosis and necrosis [552].

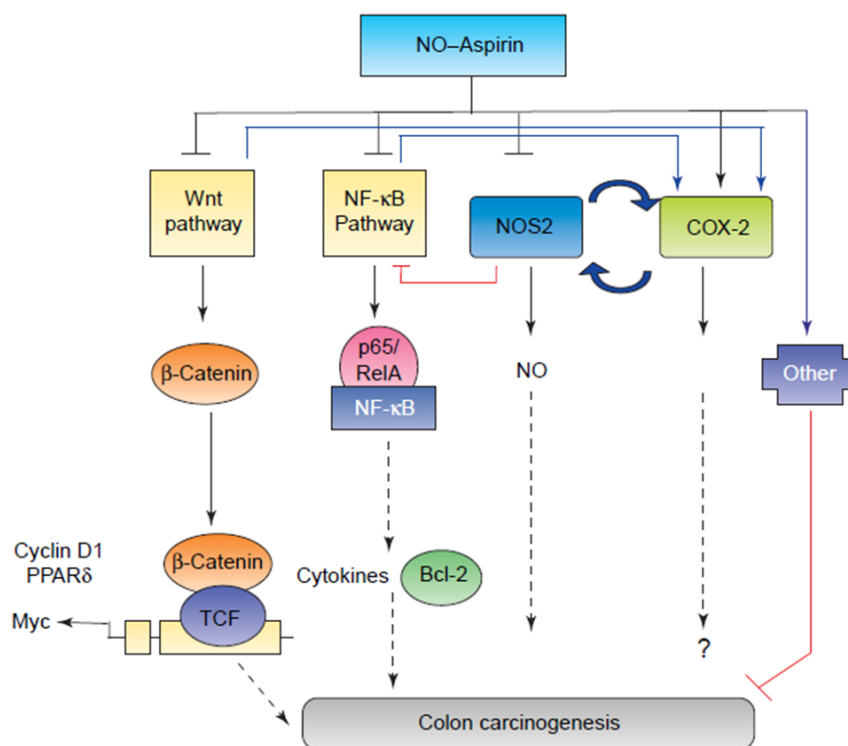

Fig. 1.31. Working model of the effect of nitric oxide (NO)-donating aspirin on signalling pathways and other molecular targets [557].

NO-ASA induces oxidative stress resulting in activation of the intrinsic apoptosis pathway and inhibition of Wnt (β -catenin) signaling (Fig. 1.31) [468]. Inhibition of Wnt signaling is a dual mechanism; the dominant mechanism operates at lower concentrations, NO-ASA, which blocked formation of β -catenin/TCF complexes; at higher concentrations β -catenin is cleaved. NO-NSAIDs also inhibit both inducible nitric oxide synthase (iNOS) [558] and NF- κ B activation (Fig.1.33) [559]. However their action on cyclooxygenases was ambiguous since different studies show conflicting results [560]. NO-NSAIDs also modulate drug metabolizing enzymes such as induction of expression and activity of NAD(P)H:quinone oxireductase (NQO) and glutathione S-transferase (GST) and translocation of Nrf2 into nucleus by binding to Keap1 [561]. NO-ASA also suppressed microsatellite instability in mismatch repair-deficient cell lines suggesting that it can be used effectively for chemoprevention of HNPCC [562].

GT-094 as anticancer agent. GT-094 (ethyl 2-((2, 3-bis (nitroxy) propyl) disulfanyl)benzoate) (Fig. 1.32) is a novel NO chimera containing three key structural features which include, an NSAID (thiosalicylate) and NO moieties and a disulfide pharmacophore. It was anticipated that GT-094 would be a prototype for the design of novel anticancer agents for treatment of colon and other cancers [563]. The use of thiosalicylate derivatives in colon cancer therapy has previously been documented and the thiosalicylate component of GT-094 was expected to be a COX-2 inhibitor which would in turn contribute to the chemopreventive activity of this compound in CRC [564, 565]. The disulfide pharmacophore is responsible for the anti-inflammatory and anti-proliferative activity and induction of cytoprotective phase II enzymes by GT-094 [563]; and other disulfides are reported to inhibit HCT-115 and Caco-2 cell proliferation by inducing a G₂-M cell cycle arrest [566-569].

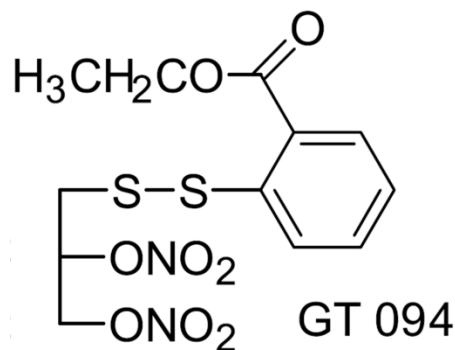

Fig. 1.32. Structure of GT-094. GT-094 releases nitrate and a NSAID moieties by rapid thiol/disulfide exchange with protein sulfhydryl groups [570].

The anticancer activity of GT-094 was observed in azoxymethane-induced colon tumors in rats [570]. GT-094 decreased azoxymethane induced colon crypt proliferation by 30 to 69%, decreased inducible NO synthase levels by 33 to 67% and also decreased aberrant crypt foci by 45% compared to untreated animals [570]. GT-094 also decreased poly (ADP-ribose) polymerase (PARP) and increased cleaved PARP (2- to 4-fold) and p27 expression in the distal colon [570]. GT-094 also decreased biomarkers of inflammation and DNA damage, such as iNOS and PARP-1 and differences between GT-094 and other NO-ASP analogs suggested that the nitrate structure influenced activity and this may be due to the activity of NO to activate both pro- and anti-apoptotic activities which is dependent on NO flux, cell type, and other factors [571].

The antiproliferative and anti-inflammatory activities of GT-094 were further confirmed in Caco-2, HT-29 human colon cancer cell lines and murine macrophage-like RAW264.7 cells [570]. GT-094 inhibits iNOS protein expression, and synthesis of PGD2

& PGE2. GT-094 also inhibits induction of several cytokines and iNOS and induces detoxifying phase 2 enzymes (NQO1) in Hepa 1c1c7 cells [563]. The mechanisms of action of GT-094 as an anticancer agent was further investigated as part of this thesis research [572].

ASCORBIC ACID AND CANCER

Ascorbic acid (Vitamin C) deficiency results in scurvy, a disease which occurs in humans whose diets lack fresh fruits and vegetables; in the mid-18th century James Lind demonstrated that the juice of fresh citrus fruits cures scurvy. The active agent was a new glucose derivative (enolic form of 3-oxo-L-gulofuranolactone) named “hexuronic acid” by the Hungarian physician Szent-Gyorgyi [573]. Szent-Gyorgyi described the antiscorbutic activity of this compound which was given the trivial name, ascorbic acid (AA) (Fig. 1.33) to designate its function in preventing scurvy [574, 575]. Ascorbic acid can be generated *de novo* by many species and is synthesized via gulonolactone oxidase in the hexuronic acid pathway in the liver or the kidney. Since humans (as well as other primates, guinea pigs and a few bat species) lack this enzyme, they cannot synthesize ascorbic acid which must be provided in the diet from fruits and vegetables [576].

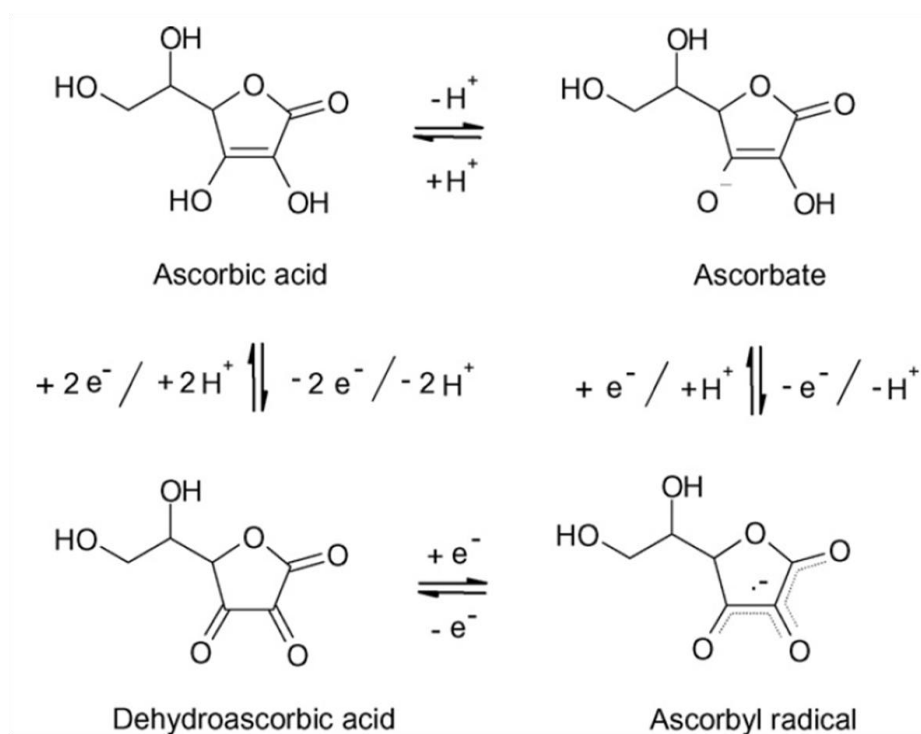

Fig. 1.33. Different states of ascorbic acid [577].

Ascorbic acid as an anticancer agent. Several studies have demonstrated that ascorbic acid, an essential micronutrient in living systems, possesses chemopreventive and chemotherapeutic properties against cancer [578-581]. However, the role of ascorbic acid in cancer treatment and its mechanism of action have remained controversial [582, 583]. The reasons for this controversy are the lack of reproducibility of the therapeutic effects of ascorbate in cancer patients [584], a problem compounded by uncertainties associated with deficiencies of independent pathologic confirmation and failure to include appropriate placebo groups in clinical studies [585-588]. However, recent studies clarified, in part, the anticancer activity of ascorbic acid. McCormick, Cameron and Rotman, postulated two hypotheses regarding the use of ascorbate for cancer treatment [589-591]; namely that, ascorbate exerts an antitumor effect by

increasing collagen synthesis [590, 591] and that ascorbate inhibits hyaluronidase, an enzyme which breaks down hyaluronic acid [589]. Pauling, Cameron and Leibovitz subsequently provided a scientific basis to support these hypotheses [581, 592].

Based on an initial study with 50 advanced cancer patients, Cameron et al., concluded that high-dose ascorbate enhanced patient survival [581]. In 1978, Cameron and Pauling subsequently showed that the long-term survival of cancer patients who received high-dose ascorbate was 20 times greater than patients in the control group (Fig.1.34) [584, 593].

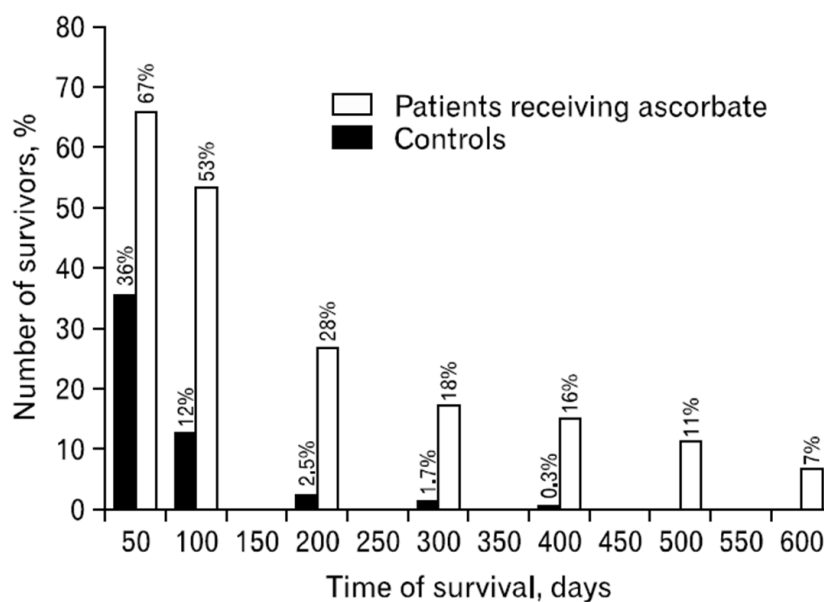

Fig. 1.34. Comparison of survival times in patients administered with or without ascorbate. Adapted from Cameron and Pauling [594].

In 1991, another prospective study showed that the survival of ascorbate-treated patients was 343 days compared to 180 days for controls who did not receive ascorbate [595]. However, Moertel and Mayo concluded that there was no significant difference in

the survival between ascorbate-treated and -untreated groups [587, 588]. The discrepancy between these findings may reflect differences in the route of ascorbate administration; Cameron administered ascorbate both orally and intravenously, while Moertel administered ascorbate exclusively through the oral route and these findings are summarized in Fig. 1.35 [596-598].

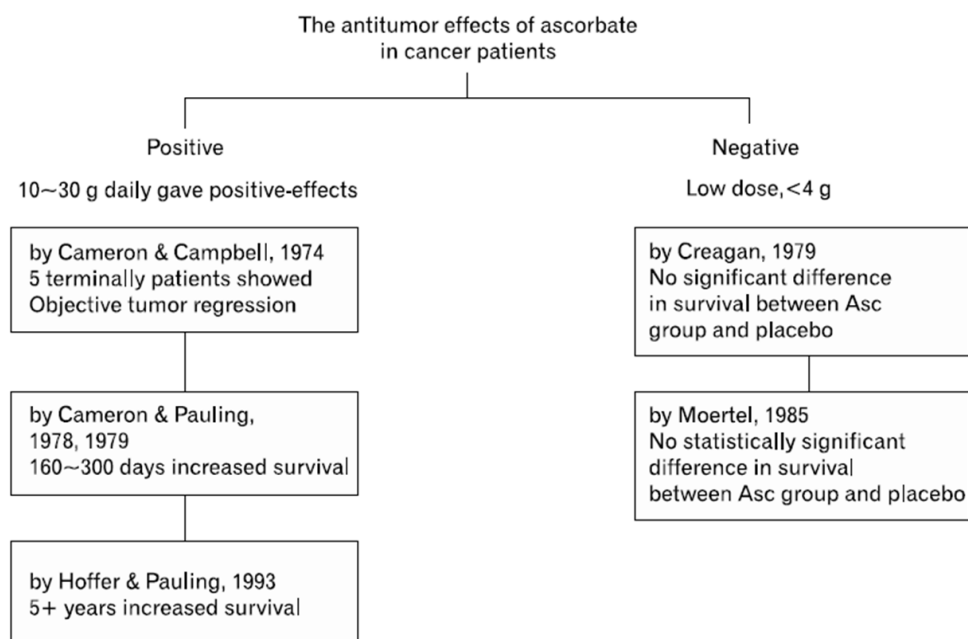

Fig. 1.35. Anticancer effects of ascorbate in cancer patients, comparison of different studies [594].

However, in the Moertel and Mayo study, most of the patients had received prior chemotherapy, whereas only few patients (4/100) in the Cameron study received prior treatment with radiation and chemotherapy [593]. It is reported that there were clinical benefits and improved survival rates using both oral and intravenously administered ascorbate in the treatment of terminal cancer [581, 584]. Later on, two double blind,

placebo-controlled trials at the Mayo clinic showed that a high oral dose of ascorbate had no effect on cancer survival [587, 588]. These trials were considered definitive, possibly because of the difference in the in vivo levels of ascorbic acid achieved between the oral and intravenous administration, which was not adequately appreciated. Plasma levels of ascorbic acid are tightly controlled and are around 50 μM [599]. Padayatty et al. have shown that intravenous administration of ascorbic acid bypasses such tight control and results in approximately a 70-fold higher concentration than those achieved by maximum oral dose [600]. Recently, Levine and coworkers have demonstrated that pharmacologic ascorbic acid concentrations achievable through intravenous administration were cytotoxic to many types of cancer cells in vitro and significantly inhibit tumor progression in vivo without being toxic to normal tissues [601]. A possible mechanism of action was proposed that involves ascorbic acid-induced formation of H_2O_2 in the extracellular fluid leading to the cytotoxic effects [602-604].

Mechanism of action of ascorbate. Several studies have shown that pharmacological (mM) concentrations of ascorbic acid kill cancer cells but not normal cells in a hydrogen peroxide (H_2O_2)-dependent manner [578, 601, 605] and these concentrations are attained in humans by i.v. infusion but not through oral administration of ascorbate [600]. Hence, ascorbic acid is hypothesized to exert local pro-oxidant effects in the interstitial fluid surrounding tumor cells, thereby inhibiting their growth or killing them, while leaving normal cells intact [578, 601, 605].

In normal physiological conditions, ascorbic acid, acts as an effective biologic antioxidant, however, ascorbate readily donates an electron (e^-) to redox-active transition metal ions, such as cupric (Cu^{2+}) or ferric (Fe^{3+}) ions, reducing them to cuprous (Cu^+) and ferrous (Fe^{2+}) ions, respectively (Reaction 1) (Fig. 1.38). In fact,

reduction of copper or iron in the catalytic site of certain enzymes contribute to the biologic functions of ascorbate as a co-substrate in procollagen, carnitine, and catecholamine biosynthesis [606]. Reduced transition metal ions, in contrast to ascorbic acid, readily react with O_2 , reducing it to superoxide radicals (Reaction 2), which in turn dismutate to form H_2O_2 and O_2 (Reaction 3) (Fig. 1.36).

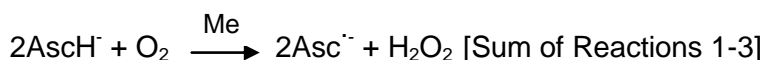
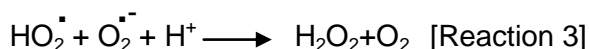
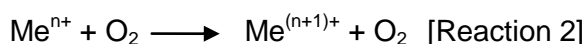
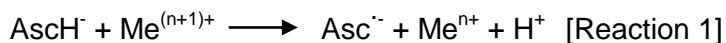

The production of H_2O_2 (Reactions 1–3) is important for the anticancer activity of ascorbate since H_2O_2 causes tumor cells to undergo apoptosis, necrosis and pyknosis [578]. In contrast, normal cells are less susceptible to H_2O_2 and the reason for the increased sensitivity of cancer cells to H_2O_2 is not clear but may be due to lower antioxidant defenses [607]. In fact, a lower capacity to destroy H_2O_2 —e.g., by catalase, peroxiredoxins, and GSH peroxidases—may cause tumor cells to grow and proliferate more rapidly than normal cells in response to low concentrations of H_2O_2 .

It is well known that H_2O_2 induces dose-dependent effects on several cell functions, including growth stimulation at very low concentrations to growth arrest, apoptosis, and eventually necrosis at higher concentrations [608]. This dose-dependency may be shifted in tumor cells, making them more sensitive to both the growth stimulatory and cytotoxic effects of H_2O_2 . The increased sensitivity of tumor cells to H_2O_2 -induced death may provide the specificity and the “therapeutic window” for the anticancer activity of extracellular ascorbate [578, 601].

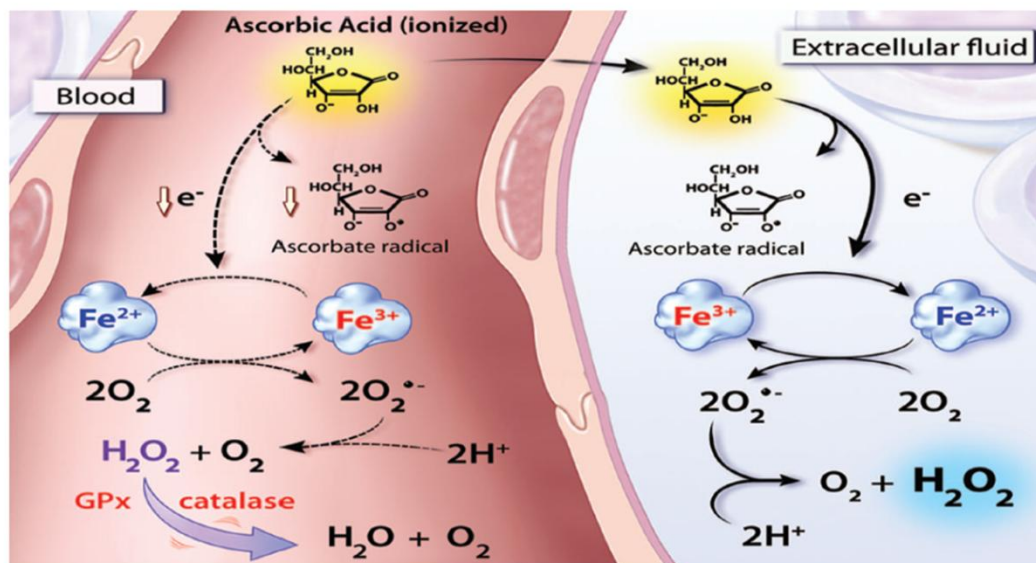

Fig. 1.36. Proposed mechanism for formation of $\text{Asc}^{\cdot-}$ and H_2O_2 in extracellular fluid compared with blood [605]. After oral and parenteral administration, ascorbic acid achieves equivalent concentrations in blood (left side) and extracellular fluid (right side). In extracellular fluid, pharmacologic concentrations of ascorbic acid lose one electron and form $\text{Asc}^{\cdot-}$. The electron reduces a protein-centered metal (Fe^{3+} to Fe^{2+}) and Fe^{2+} donates an electron to oxygen, forming active oxygen such as superoxide ($\text{O}_2^{\cdot-}$) with subsequent dismutation to H_2O_2 [609]. In blood (left side), it is proposed that these reactions are damped or inhibited (dashed lines). $\text{Asc}^{\cdot-}$ appearance will be inhibited by red blood cell membrane-reducing proteins [610] and/or by large plasma proteins that do not distribute to the extracellular space. Any formed H_2O_2 will be immediately destroyed by plasma catalase and red blood cell GSH peroxidase, so that no H_2O_2 will be detectable [587, 588, 611]. The identities of the metal-centered proteins are unknown.

The conversion of ascorbate to H_2O_2 , as explained above (Reactions 1–3), requires a redox-active transition metal and without which ascorbate cannot exhibit pro-oxidant activity. Chen *et al.* [578] proposed that there is an extracellular “metalloprotein catalyst” (10–30 kDa) that interacts with ascorbate; identification of this metalloprotein will be important because it is responsible for the action of millimolar concentrations of ascorbate as a pro-oxidant in interstitial fluid. In contrast, the metalloprotein must be

absent or inactive in blood, otherwise ascorbate would become oxidized to the ascorbyl radical or become unstable and this is not observed [601]. If this putative metalloprotein can be identified and characterized, it may also serve as an additional target for anticancer therapy. For example, other naturally occurring reducing agents, such as certain flavonoids or thiol compounds, may be particularly effective in reducing the protein's metal center, or drugs may be developed to specifically target this center. However, there is no direct evidence for the existence of the metalloprotein or formation of reduced transition metal ions by extracellular ascorbate. Chen *et al.* [601] measured the other reaction product formed between ascorbate and the putative metal center, i.e., the ascorbyl radical (Reaction 1). They also showed formation of this radical is time-dependent and dose-dependent in interstitial fluid of tissues, including tumor xenografts, but not in the blood (Fig. 1.38) [601, 605]. They also showed that the concentration of the ascorbyl radical correlates with the concentration of H_2O_2 in the interstitial fluid, whereas no H_2O_2 can be detected in the blood or plasma (Fig. 1.38) [605, 612]. These observations, combined with the inhibitory effects of ascorbate on xenograft growth, provide the proof of the concept that millimolar concentrations of extracellular ascorbate, achievable by i.p. injection or i.v. infusion in experimental animals and humans respectively, exhibits pro-oxidant and antitumorigenic activity in vivo. The mechanism of ascorbate-induced ROS (H_2O_2) and ROS-induced downstream effects in cancer cells will be investigated in this thesis research.

CHAPTER II

ASPIRIN INHIBITS COLON CANCER CELL AND TUMOR GROWTH AND DOWNREGULATES SPECIFICITY PROTEIN (Sp) TRANSCRIPTION FACTORS

INTRODUCTION

Acetylsalicylic acid or aspirin is a non-steroidal anti-inflammatory drug (NSAID) widely used for treatment of pain, fever and other inflammatory conditions [613] and the role of aspirin and other NSAIDs in cancer has been extensively investigated [614, 615]. Aspirin use is associated with decreased risk for colorectal, breast, esophageal, lung, stomach and ovarian cancer, and aspirin is both a chemopreventive and chemotherapeutic agent for breast and colon cancer [616-620]. A recent report on the chemopreventive effects of aspirin showed that the incidence of colon cancer in Scotland was significantly decreased in the general population at the lowest daily dose of aspirin (75 mg) and the decreased incidence was observed even after only 5 yr of aspirin use [619]. In another study on the chemotherapeutic effects of aspirin in colon cancer patients, a hazard ratio of 0.53 (for mortality) was observed in patients who did not use the drug prior to diagnosis and this value decreased to 0.39 for a subset of patients overexpressing COX-2 [617].

Several studies on colon cancer cells and colon tumor models have confirmed that aspirin inhibits growth and induces apoptosis in these systems; however, the specific effects of aspirin are somewhat variable in these reports. For example, aspirin downregulates bcl-2 expression [621], inhibits vascular endothelial growth factor, exhibits antiangiogenic activity [622, 623], and inhibits the Wnt/ β -catenin pathway [624]. Dunlop and coworkers have also demonstrated that aspirin-induced downregulation of

I κ B α in colon cancer cells results in enhanced nuclear accumulation of the NF- κ B complex (p65/p50) and this has been linked to a pro-apoptotic pathway in colon cancer cells [485, 625, 626].

GT-094 is a synthetic nitro-non-steroidal anti-inflammatory drug (NO-NSAID) and like aspirin, GT-094 also inhibits colon cancer cell and tumor growth [570, 627]. Mechanistic studies indicate that the anticancer activity of GT-094 is due, in part, to ROS-dependent downregulation of specificity protein (Sp) transcription factors Sp1, Sp3, Sp4 and Sp-regulated genes which include bcl-2, survivin, hepatocyte growth factor receptor (c-MET), VEGF and its receptor VEGFR1 [627]. Other drugs including NSAIDs such as tolfenamic acid and COX-2 inhibitors also inhibit cancer cell growth and downregulate Sp transcription factors [628-636] and, in this study, we have investigated the effects of aspirin on Sp proteins and other Sp-regulated genes including β -catenin. Our results show that aspirin and salicylate downregulate Sp1, Sp3, Sp4 and several Sp-regulated gene products in colon cancer cells and identifies an important pathway for the anticancer activity of aspirin that is consistent with RNA interference (RNAi) studies in which knockdown Sp1, Sp3 and Sp4 in cancer cells also inhibits growth and induces apoptosis [634-636]. Knockdown of Sp proteins also demonstrated that β -catenin is an Sp-regulated gene in colon cancer cells. Results of this study, coupled with previous reports on the mechanisms of aspirin-mediated inhibition of colon cancer cell growth, will also facilitate development of therapies with aspirin and NSAID analogs in combination with other agents used to treat colon cancer. The reported high serum salicylate/aspirin ratios observed in human studies using aspirin [637] suggest that salicylate may be an important contributor to the anticancer activity of aspirin in colon cancer patients.

MATERIALS AND METHODS

Cell lines, reagents and antibodies. RKO, SW480, HT-29 and HCT-116 human colon carcinoma cell lines were obtained from American Type Culture Collection (Manassas, VA). RKO and SW480 cells were maintained in Dulbecco's modified/Ham's F-12 (Sigma-Aldrich, St. Louis, MO) with phenol red supplemented with 0.22% sodium bicarbonate, 5% fetal bovine serum, and 10ml/L 100X antibiotic/antimycotic solution (Sigma). HT-29 and HCT-116 cells were maintained in McCoy's 5A medium (Sigma-Aldrich, St. Louis, MO) with phenol red supplemented with 0.22% sodium bicarbonate, 10% fetal bovine serum, and 10 ml/L 100X anti-biotic anti-mycotic solution (Sigma). The cells were grown in 150 cm² culture plates in an air/CO₂ (95:5) atmosphere at 37°C and passaged approximately every 3-5 days. All antibodies were purchased from Santa Cruz Biotechnology (Santa Cruz, CA), except cleaved poly (ADP) ribose polymerase (PARP) and c-Met (Cell Signaling Technology, Danvers, MA), Sp1, survivin and VEGF-R2 (Millipore, Temecula, CA), VEGFR1 and p65 (Abcam Inc. Cambridge, MA), and β -actin antibodies (Sigma-Aldrich). β -Catenin was purchased from Epitomics, Inc., Burlingame, CA. The NSAIDs acetylsalicylic acid and sodium salicylate were purchased from Sigma-Aldrich. N,N,N',N'-Tetrakis(2-pyridylmethyl)ethylenediamine (TPEN), glutathione (98%) (GSH), and lactacystin were purchased from Sigma-Aldrich (St Louis, MO). Dithiothretol (DTT) (98%) was obtained from Boehringer Mannheim Corp, (Indianapolis, IN). Caspase inhibitors 2, 8 and 9 and pancaspase inhibitor (Z-VAD-fmk) are purchased from Calbiochem (San Diego, CA). Leptomycin B was inhibitor of nuclear export purchased from Enzo Life Sciences International, Inc. (Plymouth Meeting, PA). Lipofectamine and Lipofectamine 2000 were purchased from Invitrogen. Luciferase reagent was from Promega (Madison, WI). β -Galactosidase reagent was

obtained from Tropix (Bedford, MA). NF κ B promoter construct was purchased from Stratagene (Cedar Creek, TX). The VEGF and survivin promoter constructs were provided by Drs. Gerhard Siemeister and Gunter Finkenzeller (Institute of Molecular Medicine, Tumor Biology Center, Freiburg, Germany) and Dr. M. Zhou (Emory university, Atlanta, GA), respectively. Sp1 and Sp3 promoter constructs were kindly provided by Drs. Carlos Ciudad and Veronique Noe (University of Barcelona, Barcelona, Spain).

Cell proliferation assays. RKO, SW480, HT-29 and HCT-116 colon cancer cell lines were plated (3×10^4 per well) using DMEM:Ham's F-12 medium containing 2.5% charcoal stripped fetal bovine serum (FBS) in 12-well plates and left to attach for 24 hr. Cells were then treated with either vehicle or the indicated concentrations of aspirin and sodium salicylate. After 24, 48 and 72 hr of treatment, cells were counted using a Coulter Z1 particle counter. Each experiment was carried out in triplicate and results are expressed as means \pm SE for each determination.

Annexin V staining. Apoptosis, necrotic and healthy cell detection kit was purchased from Biotium, Inc (Hayward, CA). RKO, SW480, HT-29 and HCT-116 colon cancer cells (7.5×10^4) were seeded in Lab-Tek two chambered cover glass slides and allowed to attach overnight. After treatment with aspirin (10 mM) for 24 hr, cells were washed with cold phosphate-buffered saline (PBS) twice and incubated with FITC Annexin V, ethidium homodimer III and Hoechst 33342 in Annexin V binding buffer for 20 min according to the manufacturer's instructions in the protocol. The cells were then washed twice with Annexin V binding buffer and fluorescence was analyzed with a digital fluorescence microscope.

siRNA interference assays. SiRNAs for Sp1, Sp3, Sp4, and Lamin were purchased from Sigma-Aldrich. The siRNA complexes used in this study are indicated as follows:

Lamin: SASI_Hs02_00367643

Sp1: SASI_Hs02_00363664

Sp3 5'-GCG GCA GGU GGA GCC UUC ACU TT

Sp4 5'-GCA GUG ACACAU UAG UGA GCT T

RKO and SW480 colon cancer cell lines were seeded (6×10^4 per ml) in 6-well plates in DMEM:Ham's F-12 medium supplemented with 2.5% charcoal-stripped FBS without antibiotic and left to attach for 1 d. Knockdown of Sp1, Sp3, Sp4 individually or a combination of all 3 proteins was carried out using appropriate siRNA along with iLamin as control was performed using LipofectAMINE 2000 transfection reagent as per the manufacturer's instructions.

Transfection and luciferase assay. RKO and SW480 colon cancer cells (1×10^5 per well) were plated in 12-well plates in DMEM/Ham's F-12 medium supplemented with 2.5% charcoal-stripped FBS. After 24 hr, various amounts of DNA [i.e., 0.4 μ g PGL3-Luc, 0.04 μ g β -galactosidase, and 0.4 μ g pNF κ B-Luc (4)-Luc] were transfected using LipofectAMINE 2000 reagent according to the manufacturer's protocol. After 5 hr of the transfection, the transfection mix was replaced with complete medium containing either vehicle (DMSO) or the indicated compound in DMSO.

For RNA interference studies, RKO and SW480 colon cancer cells were cotransfected with siRNA for Sp1, Sp3, Sp4 or Lamin along with various amounts of DNA for PGL3-Luc or 0.4 μ g pNF κ B-Luc. After 22 hr, cells were then lysed with 100 μ L of 1X reporter lysis buffer, and cell extracts (30 μ L) were used for luciferase and β -galactosidase assays. A Lumicount luminometer was used to quantitate luciferase and

β -galactosidase activities, and the luciferase activities were normalized to β -galactosidase activity.

Western blots. RKO, SW480, HT-29 and HCT-116 colon cancer cells were seeded in DMEM:Ham's F-12 medium containing 2.5% charcoal-stripped FBS and, after 24 hr, cells were treated with either vehicle (DMSO) or the indicated compounds. Cells were collected using high-salt buffer (50 mM HEPES, 0.5 mol/L NaCl, 1.5 mM MgCl₂, 1 mM EGTA, 10% glycerol, and 1% Triton-X-100) and 10 ml/L Protease Inhibitor Cocktail (Sigma-Aldrich). After centrifugation of the lysates at 15,000 *g* for 15 min at 4°C, the supernatants were recovered, and protein was quantified by the Bradford protein assay. Protein lysates (15-60 μ g) were incubated for 5 min at 100°C along with 5X loading buffer and then separated by electrophoresis on 7.5-12% sodium dodecyl sulphate-polyacrylamide gels at 120 V for 3 to 4 hr. Proteins were transferred onto polyvinylidenedifluoride membranes by wet electroblotting in a buffer containing 25 mM Tris, 192 mM glycine, and 20% methanol for 1.5 hr at 180 mÅ. Membranes were blocked for 45 min with 5% TBST-Blotto (10 mM Tris-HCl, 150 mM NaCl, pH 8.0, 0.05% Triton X-100, and 5% nonfat dry milk) and incubated in fresh 5% TBST-Blotto with 1:500 primary antibody overnight with gentle shaking at 4°C. After washing twice with TBST for 10 min, the membrane was incubated with secondary antibody (1:5000) in 5% TBST-Blotto for 3-4 hr by gentle shaking. The membrane was washed twice with TBST for 10 min, incubated with 2 ml of chemiluminescence substrate (Millipore, Temecula, CA) for 1 min, and exposed to Kodak image station 4000 mm Pro (Carestream Health, Rochester, NY).

Xenograft studies in athymic mice. Female athymic (nude) mice were purchased from Harlan Laboratories (Indianapolis, IN). The mice were housed and maintained

under specific pathogen-free conditions in facilities approved by the American Association for Accreditation of Laboratory Animal Care and in accordance with current regulations and standards of the United States Department of Agriculture, United States Department of Health and Human Services. The mice were used in accordance with institutional guidelines. To produce tumors, RKO cells were harvested from subconfluent cultures by a brief exposure to 0.25% trypsin and 0.02% ethylenediaminetetraacetic acid. Trypsinization was stopped with medium containing 10% fetal bovine serum, and the cells were washed once in serum-free medium and resuspended in serum free medium. Only suspensions consisting of single cells with 90% viability were used for the injections. A xenograft was established by subcutaneous injection of the cells (3×10^6) into the flanks of individual mice. Tumors were allowed to grow for 6 d until they were palpable. Mice were then randomized into two groups of 6 mice per group and dosed by oral gavage in corn oil 200 mg/kg/day (neutralized with an equimolar concentration of NaOH) of aspirin on every day for 14 d. The mice were weighed, and tumor size was measured every second day with calipers to permit calculation of tumor volumes: $V=LW^2/2$, where L and W were length and width, respectively. After 14 d, the animals were sacrificed; final body and tumor weights were determined and plotted. At the end of the experiment, major visceral organs and tumors were collected and analyzed for Sp protein expression and induction of apoptosis using western blots and TUNEL staining respectively.

Statistical analysis. Statistical significance of differences was determined by analysis of variance and student t-test, and the levels of probability were noted. All statistical tests were two-sided. IC_{50} values were calculated using non-linear regression analysis and expressed in μM , at 95% confidence intervals.

RESULTS

Aspirin inhibits growth and induces apoptosis in colon cancer cells. In this study, different concentrations (2.5-10 mM) of aspirin inhibited growth of SW480, RKO, HT-29 and HCT-116 cells over a period of 3 days (Figs. 2.1A and 2.1B), and IC_{50} values for aspirin-induced growth inhibition were in the range of 2.5-5 mM in all 4 cell lines. The high dose (10 mM) of aspirin was used to determine the proapoptotic effects of this compound after treatment for only 24 hr and the results show that aspirin increased Annexin V staining in all 4 colon cancer cell lines (Fig. 2.1C). The proapoptotic effects of aspirin (5 and 10 mM) were further investigated in colon cancer cells by determining changes in expression in the survival proteins bcl-2 and survivin and induction of caspase-dependent PARP cleavage. Aspirin induced a concentration- and time-dependent downregulation of survivin and bcl-2 and induced of PARP cleavage, a marker of apoptosis (Figs. 2.1D and 2.1E).

Aspirin and salicylate downregulates Sp1, Sp3, Sp4 and Sp-regulated genes.

Previous studies by RNA interference (RNAi) show that both survivin and bcl-2 are regulated by Sp1, Sp3 and Sp4 in cancer cells [627, 632, 634-636]. Therefore, RKO, SW480, HT-29 and HCT-116 cells were treated with 5 and 10 mM aspirin for 24 or 48 hr and western blot analysis showed that there was a concentration- and time-dependent decrease in Sp1, Sp3 and Sp4 proteins in all 4 cell lines (Figs. 2.2A and 2.2B).

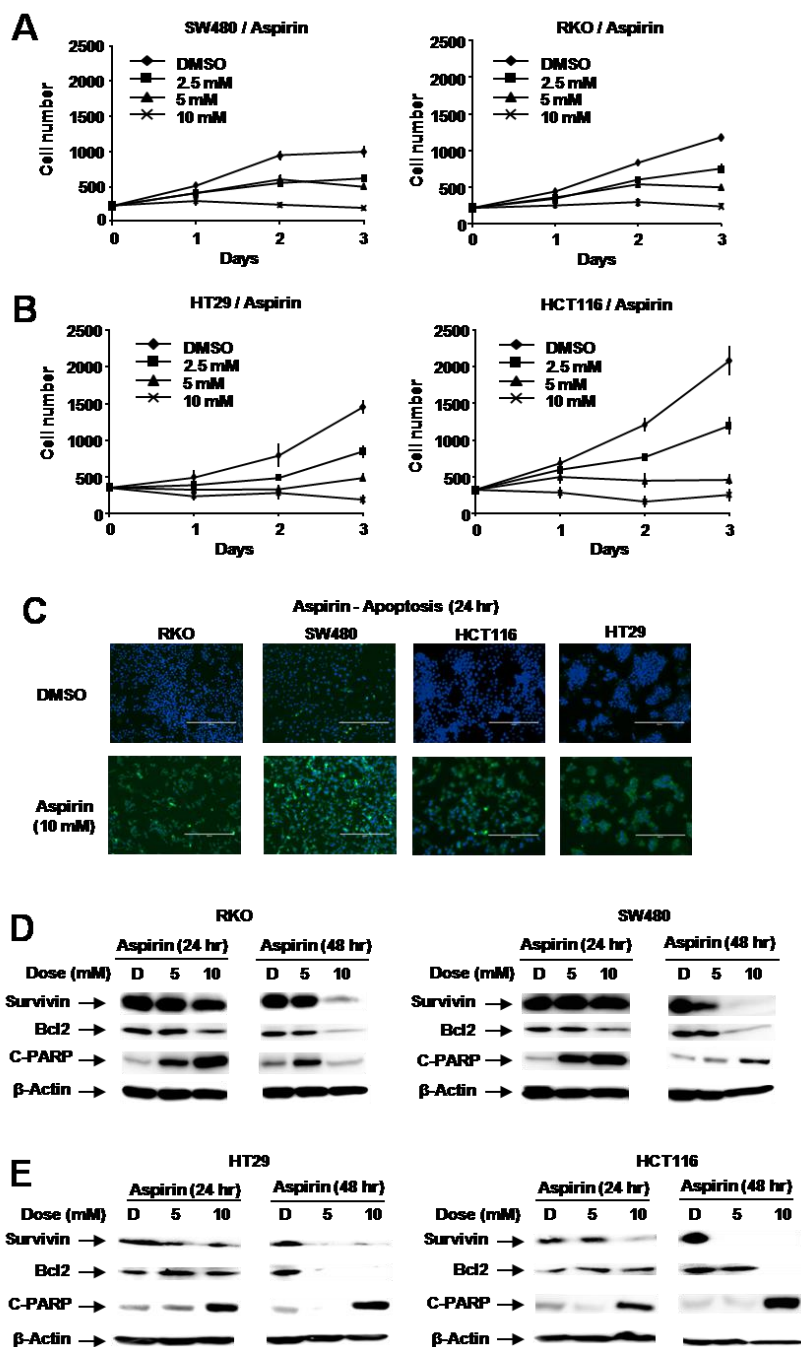

Fig. 2.1. Aspirin inhibits colon cancer cell growth and induces apoptosis. Inhibition of SW480 and RKO (A) and HT-29 and HCT-116 (B) cell proliferation. Cells were treated with DMSO or 2.5-10 mM aspirin for 3 days, and cell numbers were determined as described in the Experimental Procedures. Induction of Annexin V staining (C) and apoptotic responses in RKO and SW480 (D) and HT-29 and HCT-116 (E) cells. Annexin V staining was determined as described in the Experimental Procedures. The expression of apoptotic proteins PARP cleavage was determined by western blot analysis of whole cell lysates as described in the Experimental Procedures. Results in (A) and (B) are means \pm SE for 3 replicate determination for each treatment group, and significant ($p < 0.05$) inhibition is indicated (*).

Moreover, treatment of RKO, SW480, HT-29 and HCT-116 colon cancer cells with 5 or 10 mM aspirin for 24 or 48 hr also decreased expression of several gene products regulated by Sp1, Sp3 and Sp4 [634-639] and these include VEGF, VEGFR1, cyclin D1 and c-MET proteins, and the effects of aspirin on their expression were both concentration- and time-dependent.

We also investigated the effects of 5 and 10 mM aspirin on luciferase activity in RKO and SW480 cells transfected with constructs containing GC-rich promoter inserts from the Sp1 (pSp1For4, -751 to -20), Sp3 (pSp3For5, -417 to -38), VEGF (pVEGF, -2018 to +50), and survivin (pSurvivin, -269 to +49) genes (Fig. 2.2E). With the exception of the VEGF construct, 5 and 10 mM aspirin significantly decreased luciferase activity and these results correlated with the decreased expression of the corresponding Sp1, Sp3, VEGF and survivin proteins in RKO and SW480 cells. The increase in luciferase activity in RKO cells treated with 5 mM aspirin and transfected with pVEGF may be due to the relatively slow downregulation of this protein which was only observed after 48 hr at the 10 mM concentration, suggesting that other aspirin-induced pathways may also be activating VEGF.

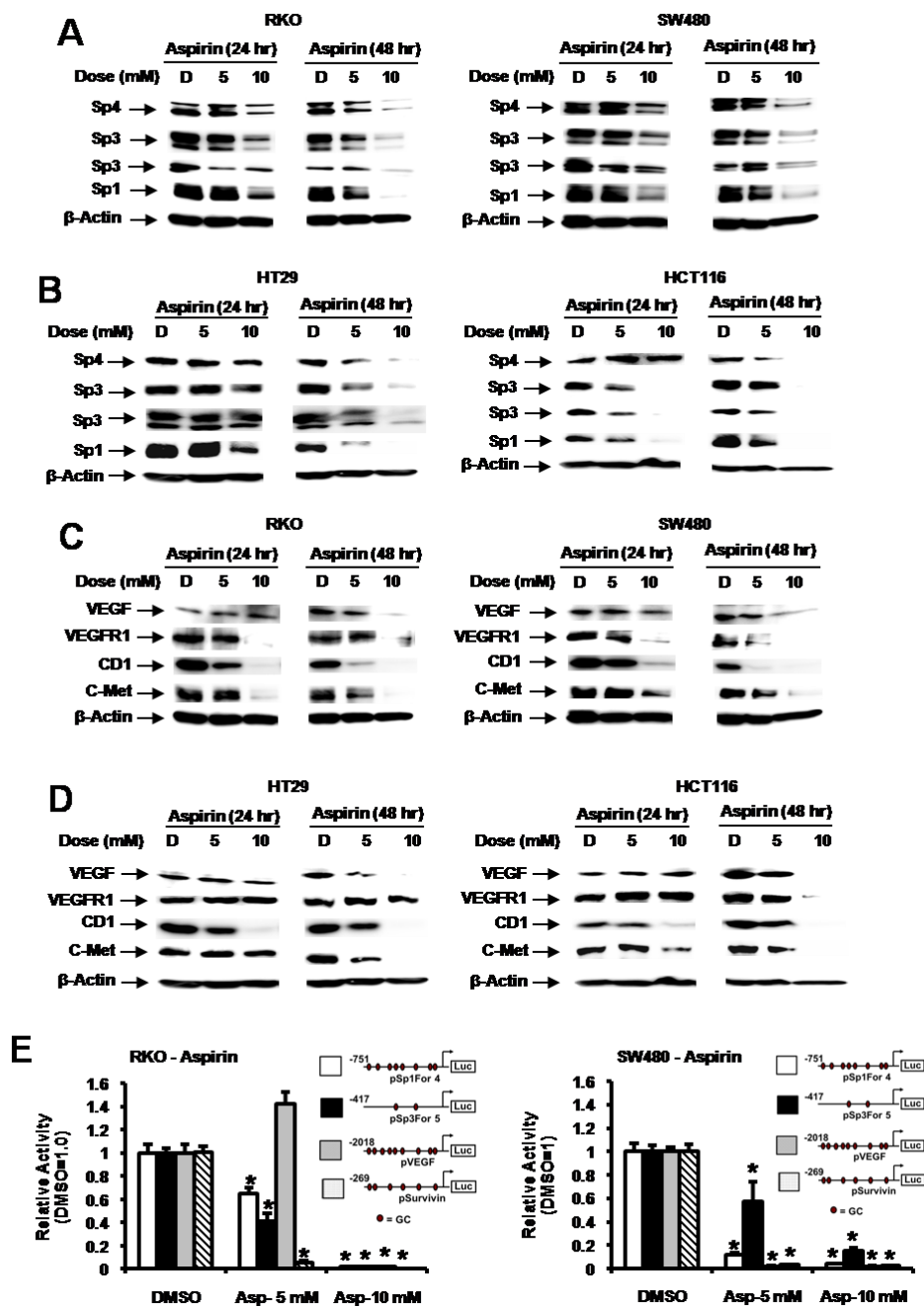

Fig. 2.2. Aspirin decreases expressions of Sp1, Sp3, Sp4 and Sp-regulated gene products in colon cancer cells. Downregulation of Sp proteins in RKO and SW480 (A) and HT-29 and HCT-116 (B) and Sp-regulated gene products in RKO and SW480 (C) and HT-29 and HCT-116 (D) cells. Cells were treated with 5 or 10 mM aspirin for 24 or 48 hr, and whole cell lysates were analyzed by western blot analysis as described in the Experimental Procedures. Results are typical of duplicate experiments. (E) Aspirin decreases reporter gene activity. Cells were transfected with pSp1For4, pSp3For5, pVEGF and pSurvivin and treated with DMSO or aspirin (5 or 10 mM). Luciferase activity was determined as described in the Experimental Procedures. Results are expressed as means \pm SE (3 replicates) and significant ($p < 0.05$) inhibition is indicated (*).

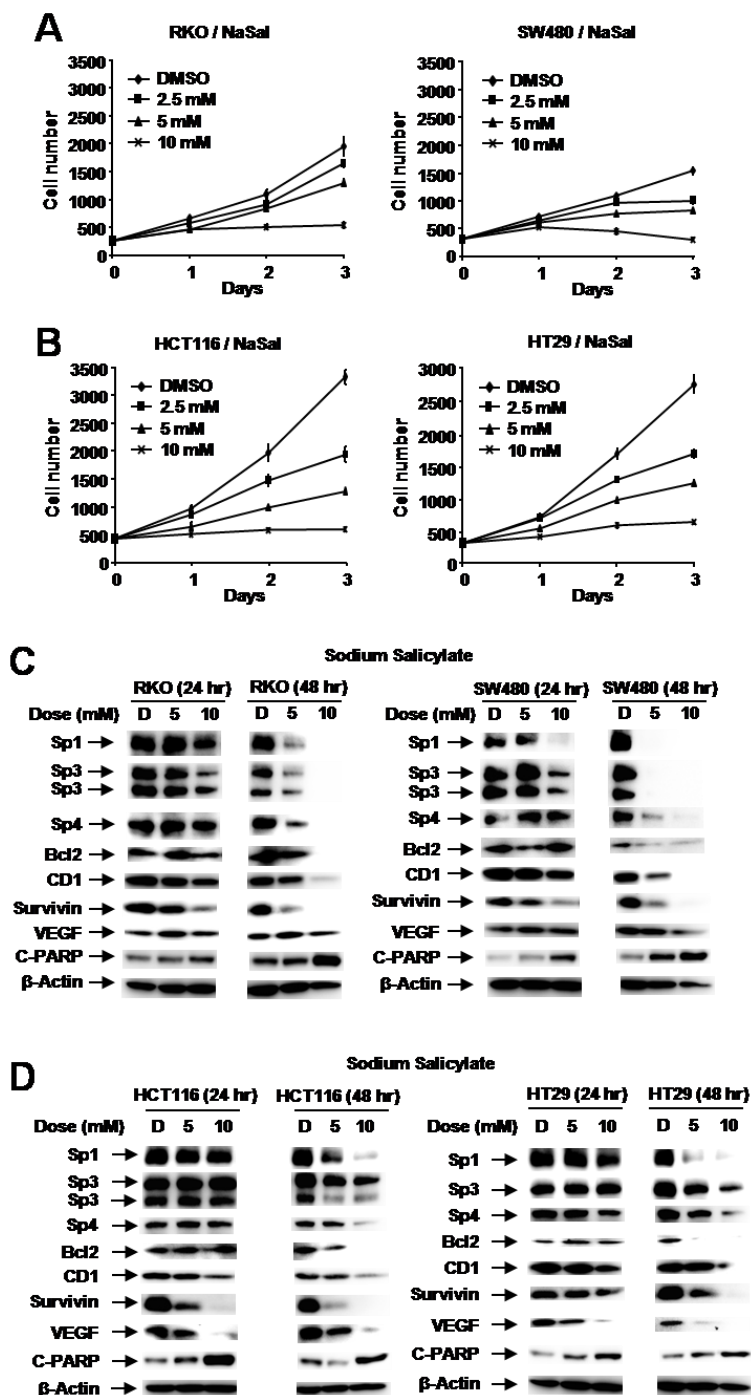

Fig. 2.3. Salicylate inhibits colon cancer cell growth and downregulates Sp1, Sp3, Sp4 and Sp-regulated genes. Inhibition of RKO and SW480 (A) and HCT-116 and HT-29 (B) cell growth. Cells were treated with 2.5-10 mM sodium salicylate for up to 3 days, and cell numbers were determined as described in the Experimental Procedures. Protein downregulation in RKO and SW480 (C) and HCT-116 and HT-29 (D) cells. Cells were treated with 5 or 10 mM salicylate for 24 or 48 hr, and whole cell lysates were analyzed by western blot analysis as described in the Experimental Procedures.

Aspirin is rapidly metabolized to salicylate [637] and the effects of salicylate on colon cancer cell growth, Sp proteins and Sp-regulated genes was also investigated (Fig. 2.3). Salicylate (sodium salt) (2.5-10 mM) also inhibited growth of all 4 cell lines (Figs. 2.3A and 3B), and the growth inhibitory effects were similar to that observed for aspirin (Figs. 2.2A and 2.2B). Growth inhibition was accompanied by the time-dependent downregulation of Sp1, Sp3, Sp4 and Sp-regulated gene products (bcl-2, cyclin D1, survivin and VEGF) in RKO and SW480 (Fig. 2.3C) and HCT-116 and HT-29 (Fig. 2.3D) cells. This pattern of responses for sodium salicylate was comparable to that observed for aspirin (Figs. 2.1 and 2.2) and similar effects were also observed for methyl salicylate (data not shown) which is also rapidly metabolized to salicylate.

Aspirin-induced suppression of NF- κ B and β -catenin is due, in part, to Sp-downregulation. It has previously been reported that aspirin enhanced nuclear NF- κ B accumulation [485, 625, 626] and this was further investigated in RKO and SW480 cells treated with 5 and 10mM aspirin for 48 hr. Levels of cytosolic p65 and p50 levels were decreased, whereas nuclear p65 and p50 levels were relatively unchanged after treatment with aspirin (Figs. 2.4A and 2.4B) and these results differed with previous studies [485, 625, 626]. Moreover, overall levels of nuclear proteins were <10% of cytosolic proteins and this was confirmed by western blot analysis of whole cell lysates from cells treated with 5 or 10 mM aspirin which showed that both p65 and p50 proteins were decreased in both cell lines within 48 hr after treatment with aspirin (Figs. 2.4A and 2.4B). Aspirin also decreased luciferase activity in SW480 and RKO cells transfected with a pNF- κ B-luc construct (Fig. 2.4C) and these results were consistent with the observed downregulation of both p65 and p50 proteins (Figs. 2.4A and 2.4B).

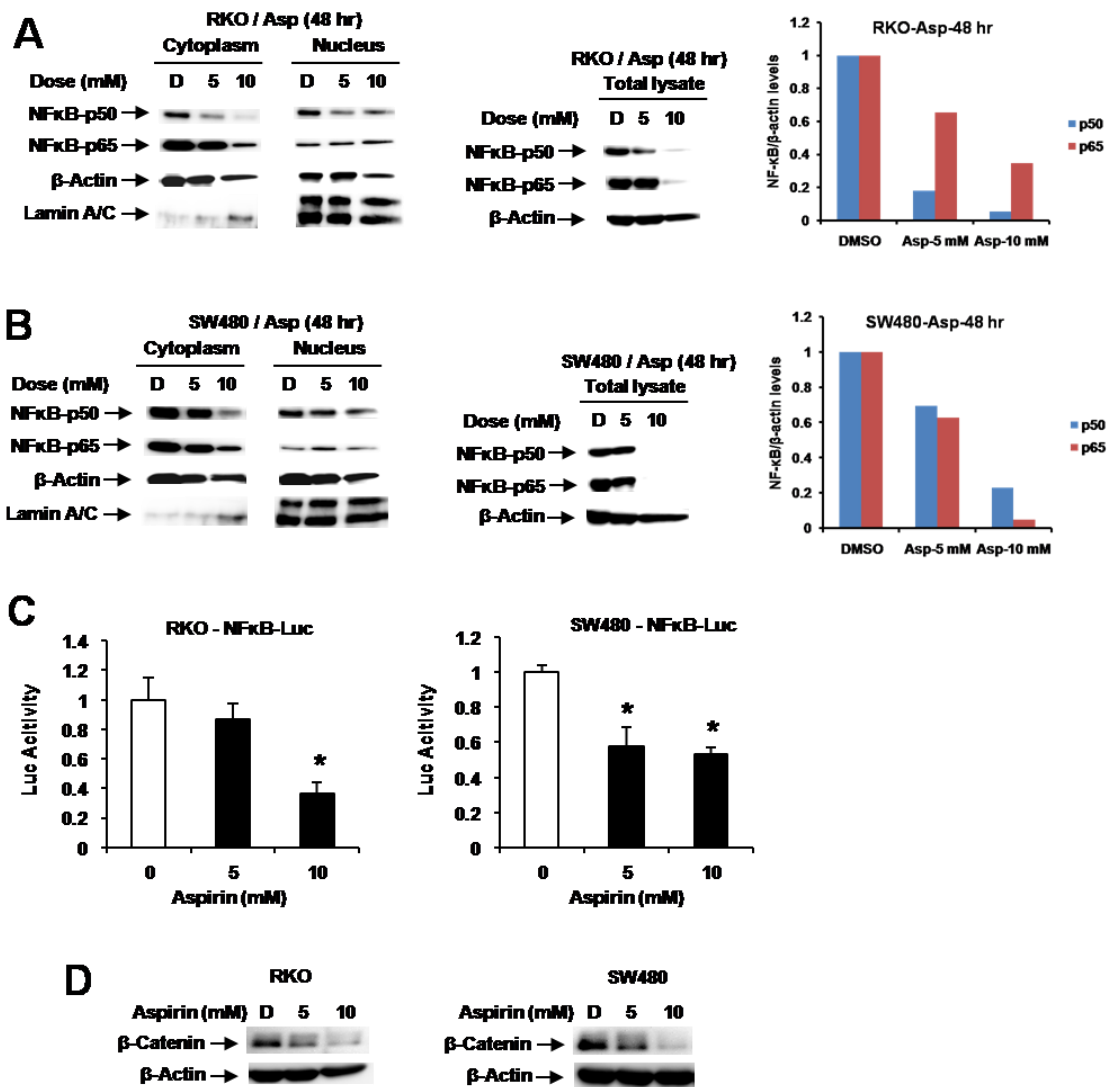

Fig. 2.4. Aspirin decreases expression of NFκB and β-catenin in colon cancer cells. Decreased p65/p50 in RKO (A) and SW480 (B) cells. Cells were treated for 48 hr with 5 or 10 mM, and whole cell, nuclear and cytosolic extracts were analyzed by western blot analysis as described in the Experimental Procedures. (C) Aspirin decreases NFκB-luc. The construct was transfected into RKO and SW480 cells treated with DMSO or aspirin, and luciferase activity determined as described in the Experimental Procedures. Results are means ± SE (3 replicates) and significant ($p < 0.05$) inhibition is indicated (*). (D) Downregulation of β-catenin. Cells were treated with 5 or 10 mM aspirin for 48 hr, and whole cell lysates were analyzed by western blot analysis as described in the Experimental Procedures.

Previous studies reported that aspirin decreased β -catenin expression in colon cancer cells [624] and our results confirmed that 5-10 mM aspirin also decreases β -catenin expression in RKO and SW480 colon cancer cells (Fig. 2.4D).

Since NF- κ B (p65) and the β -catenin promoters contain GC-rich Sp binding sites [638, 639], we used RNAi to determine the role of Sp1, Sp3 and Sp4 in regulation of p65, p50 and β -catenin in colon cancer cells. RKO and SW480 cells were transfected with small inhibitory RNAs targeting Sp1 (iSp1), Sp3 (iSp3), and Sp4 (iSp4) alone and in combination (iSp1/3/4). Figure 2.5A shows that each individual oligonucleotide decreased expression of its individual target (Sp1, Sp3 and Sp4) and iSp1/3/4 knocked down all three proteins. iSp1 also decreased expression of Sp4 (but not Sp3) and this is consistent with previous studies showing cross-regulatory interactions among the Sp transcription factors due to their GC-rich promoters [632, 635]. Fig. 2.5B illustrates cell context-dependent differences in the effects of iSp1, iSp3 and iSp4 on p65 expression in RKO and SW480 cells where Sp1, Sp3 and Sp4 knockdown resulted in small changes in p65 in RKO cells and Sp1 and to a lesser extent Sp4 knockdown decreased p65 in SW480 cells. iSp1/3/4 (combined oligonucleotides) decreased p65 expression in both cell lines, whereas minimal effects were observed for p50. Thus, aspirin-induced downregulation of p50 (Figs. 2.4A and 2.4B) was Sp-independent. Fig 2.5C shows that iSp1/3/4 also decreased luciferase activity in RKO (90%) and SW480 (40%) cells transfected with the NF- κ B-luc construct, and the different effects of Sp knockdown in these cells suggest a more dominant role for Sp-dependent regulation of NF- κ B in RKO than SW480 cells. Sp knockdown (combined) also decreased β -catenin protein in RKO and SW480 cells and results of knockdown of individual Sp proteins suggest that Sp1 and Sp4 are the dominant transcription factors required for constitutive expression of β -

catenin in RKO cells, whereas knockdown of Sp1, Sp3 and Sp4 decrease β -catenin protein levels in SW480 cells (Fig. 2.5D).

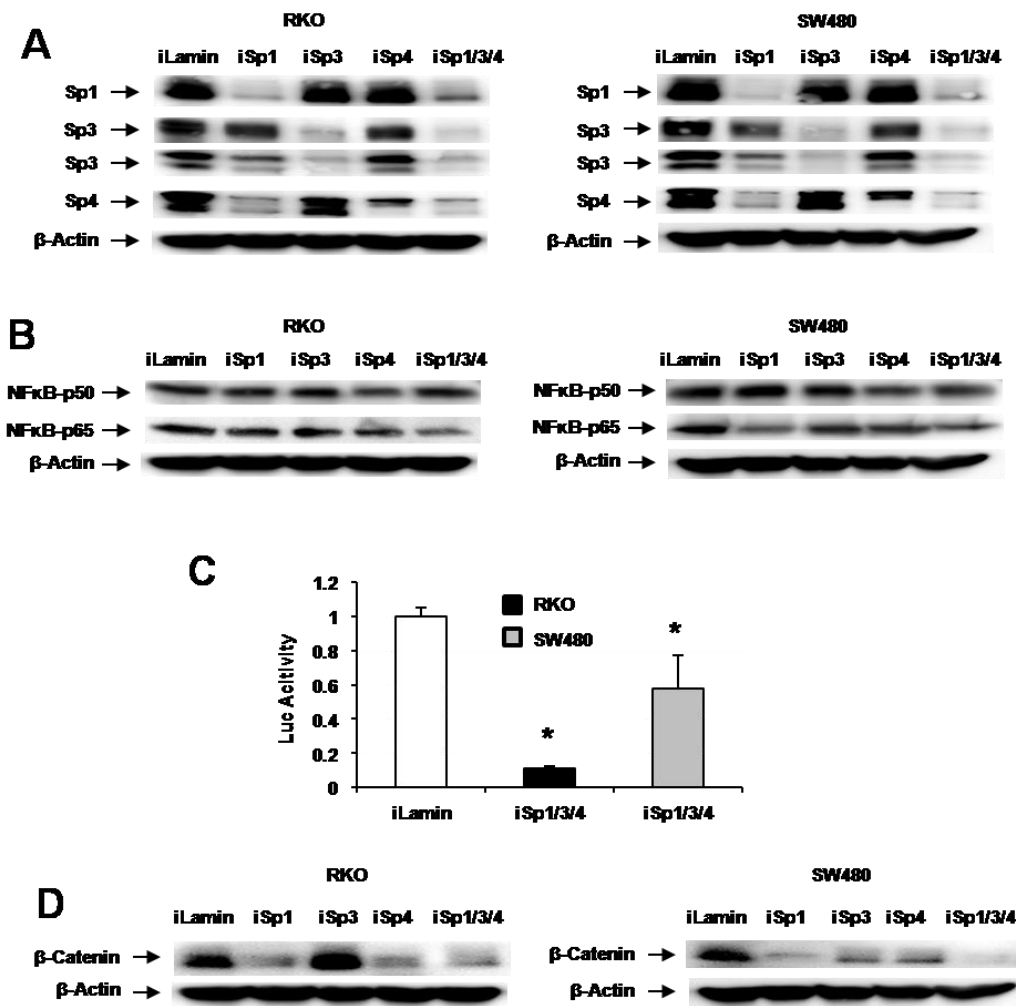

Fig. 2.5. Knockdown of Sp1, Sp3 and Sp4 (alone and combined) by RNA interference. Knockdown of Sp1, Sp3, Sp4 and Sp1/3/4 (A) and p65/p50 (B) in colon cancer cells. Cells were transfected with various oligonucleotides, and whole cell lysates were analyzed by western blot analysis as outlined in the Experimental Procedures. (C) Knockdown of Sp1/3/4 (combined) inhibits NF κ B-luc. Cells were transfected with iLamin (control) and iSp1/3/4 (combined oligonucleotides) and NF κ B-luc, and luciferase activity was determined as described in the Experimental Procedures. Results are expressed as means \pm SE (3 replicates), and significantly ($p < 0.05$) decreased activity is indicated (*). (D) Sp knockdown decreases β -catenin. Cells were transfected with various oligonucleotides, and whole cell lysates were analyzed by western blot analysis as described in the Experimental Procedures.

Mechanism of aspirin-induced downregulation of Sp1, Sp3 and Sp4. Several pathways have been described for enhanced Sp degradation in cancer cell lines and these include activation of proteasomes, caspases and ROS [627-630, 632-636] and also a pathway which involves nuclear export of Sp1 followed by proteolytic degradation in the cytosol [640]. Western blot analysis of nuclear and cytosol fractions from RKO and SW480 cells show that Sp1, Sp3 and Sp4 are localized in the nucleus and treatment with aspirin decreased Sp1, Sp3 and Sp4 protein levels in the nucleus without any apparent translocation to the cytosol (Fig. 2.6A). Similar results were observed after cotreatment with aspirin and the nuclear export inhibitor leptomycin B (combined), indicating that nuclear export of Sp1, Sp3 or Sp4 was not required for aspirin-induced downregulation of Sp1, Sp3 and Sp4. Other agents such as the nitro-NSAID GT-094 and betulinic acid decreased Sp proteins in RKO and SW480 cells through ROS-dependent induction of Sp transcriptional repressor ZBTB10 and this response was attenuated by antioxidants such as GSH or DTT [627, 641]; however, results in Fig. 2.6B show that these antioxidants do not block aspirin-induced downregulation of Sp proteins. Results of preliminary studies show that aspirin-induced downregulation of Sp proteins was also not blocked by proteasome inhibitors (data not shown) but was affected by cotreatment with the pancaspase inhibitor Z-VAD-fmk. Figs. 2.6C and 2.6D show that aspirin-induced Sp downregulation in RKO and SW480 cells was inhibited after cotreatment with the pancaspase inhibitor (Z-VAD-fmk), caspase-2 (Z-VDVAD-fmk), and caspase-8 (Z-IETD-fmk) inhibitors but only partially blocked with the caspase-9 (Z-LEHD-fmk) inhibitor.

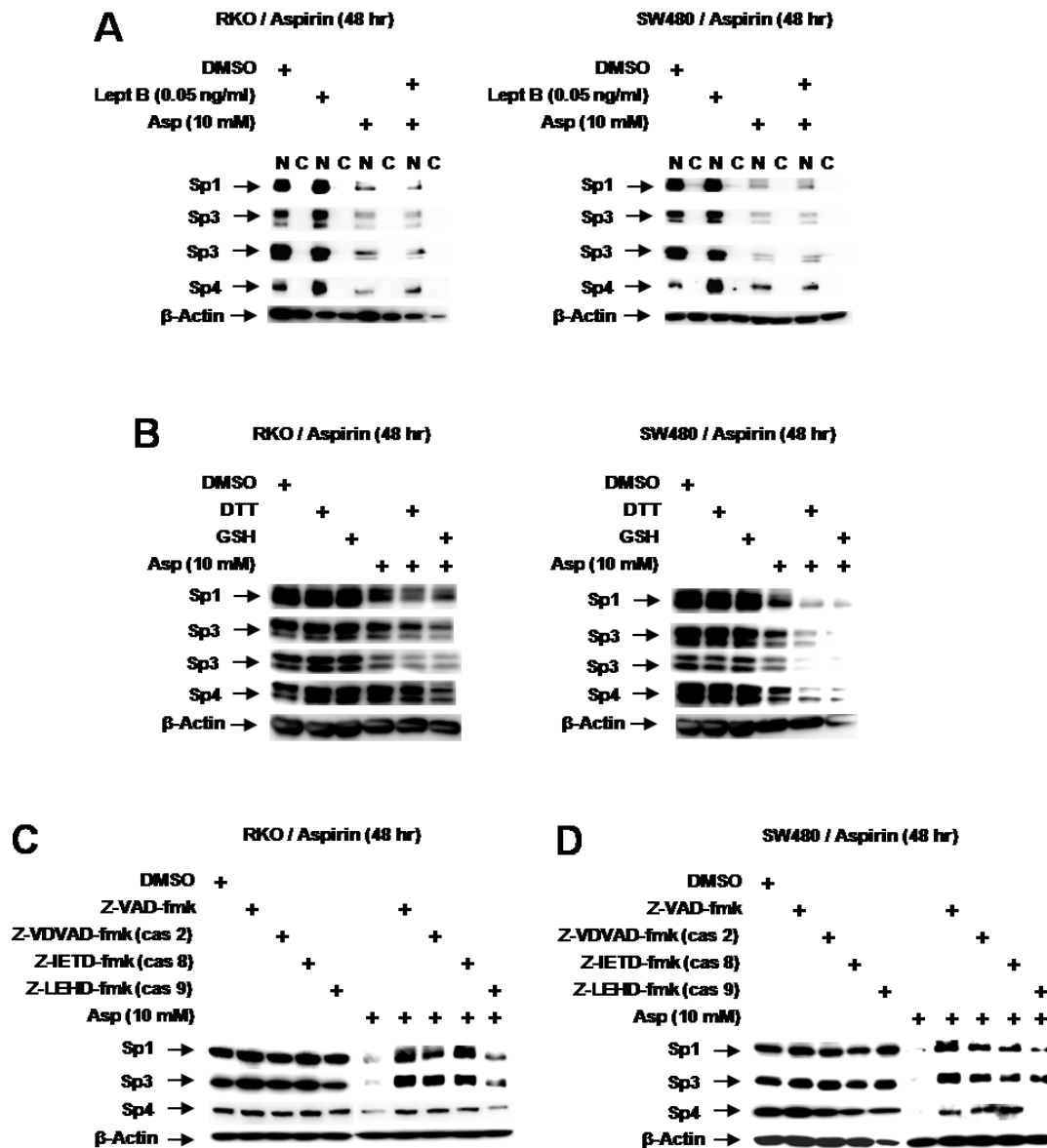

Fig. 2.6. Mechanisms of aspirin-induced Sp protein degradation. (A) Effects of leptomycin B. Cells were treated with 10 mM aspirin in the presence or absence of leptomycin B for 48 hr, and whole cell lysates were analyzed by western blot analysis as described in the Experimental Procedures. Effects of antioxidants (B) and caspase inhibitors (C, D) on aspirin-induced Sp protein downregulation. Cells were treated with DMSO, aspirin alone or in combination with antioxidants or caspase inhibitors, and after 48 hr, whole cell lysates were analyzed by western blot analysis as described in the Experimental Procedures.

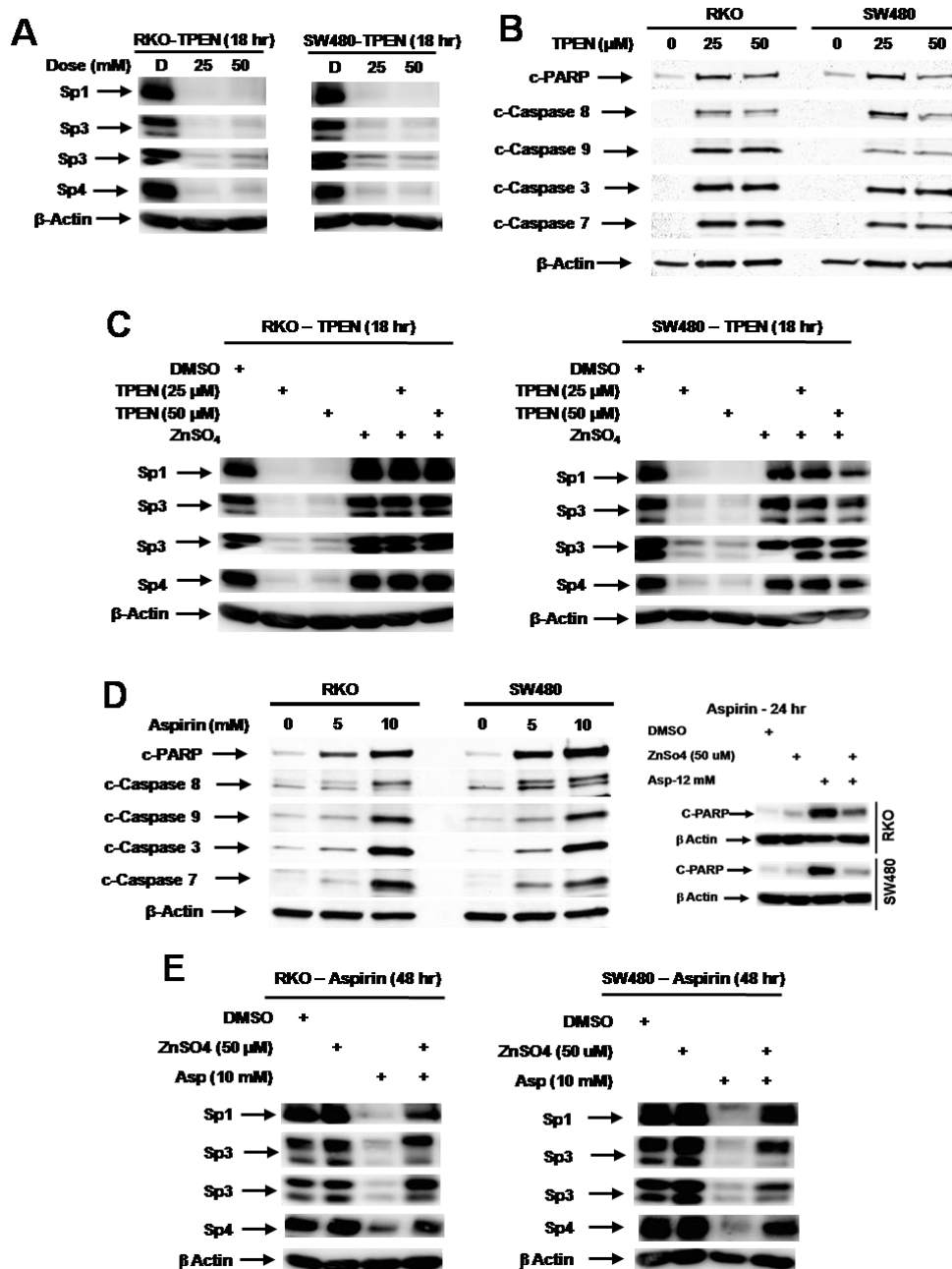

Fig.2.7. Zinc depletion results in downregulation of Sp proteins. TPEN decreases levels of Sp1, Sp3 and Sp4 proteins (A) and induces activation (cleavage) of caspases(B). Cells were treated with 25 or 50 μ M TPEN for 18 hr, and whole cell lysates were analyzed by western blots as described in the Experimental Procedures. (C) Zinc sulfate blocks the effects of TPEN on Sp downregulation. Cells were treated with 50 μ M ZnSO₄ for 18 hr, and whole cell lysates were analyzed by western blots. (D) Aspirin activates caspases. Cells were treated with aspirin for 48 hr, and whole cell lysates were analyzed by western blots as outlined in the Experimental Procedures. (E) Effects of ZnSO₄ on aspirin-induced downregulation of Sp proteins. RKO or SW480 cells were treated with 10 mM aspirin alone or in combination with 50 μ M ZnSO₄ for 48 hr, and whole cell lysates were analyzed by western blots as outlined in the Experimental Procedures.

Favier and coworkers [642, 643] previously reported in HeLa cells that zinc chelation by the permeable metal ion chelator TPEN activated multiple caspases (3-, 8- and 9-) and decreased expression of Sp1, Sp3 and Sp4 proteins that contain zinc ions in their catalytic sites. Results in Fig. 2.7A show that after treatment of RKO and SW480 cells with 25 or 50 μM TPEN for 18 hr, there was a dramatic decrease in Sp1, Sp3 and Sp4 protein expression and this was accompanied by induction of PARP cleavage and activation (cleavage) of caspases 8, 9, 3, and 7 (Fig. 2.7B). The critical role of zinc depletion in mediating this response was confirmed by treating the colon cancer cells with TPEN alone or in combination with 50 μM ZnSO_4 (Fig. 2.7C). The addition of ZnSO_4 completely reversed the TPEN-dependent downregulation of Sp1, Sp3 and Sp4 proteins. Like TPEN, aspirin also induced PARP cleavage and activation (cleavage) of caspases 8, 9, 3 and 7 (Fig. 2.7D). Moreover, treatment of RKO and SW480 cells with aspirin alone or in combination with 50 μM ZnSO_4 and the results show that ZnSO_4 also decreased aspirin-mediated downregulation of Sp1, Sp3 and Sp4 (Fig. 2.7E), thus confirming that aspirin, like TPEN, induces caspase-dependent cleavage of Sp proteins that is due to zinc ion depletion.

In vivo studies. In athymic nude mice bearing RKO cells as xenografts, aspirin was administered when the tumors were initially palpable. The sodium salt of aspirin (200 mg/kg/d) was administered daily by oral gavage and this resulted in decreased tumor volumes and weights (Figs. 2.8A and 2.8B) and due to the lack of toxicity of the sodium salt, the treatment was continued for several days without any apparent signs of toxicity. Tumor lysates from control and treated animals were analyzed by western blot analysis for Sp1, Sp3 and Sp4, and levels were quantified relative to β -actin and showed significant decreases in expression of Sp1, Sp3 and Sp4 in aspirin vs. control animals

(Fig. 2.8C). Fig. 2.8D shows increased apoptosis (TUNEL staining) in tumors from aspirin-treated mice compared to controls and these results complement *in vitro* studies showing that aspirin induced apoptosis in colon cancer cells (Fig. 2.1).

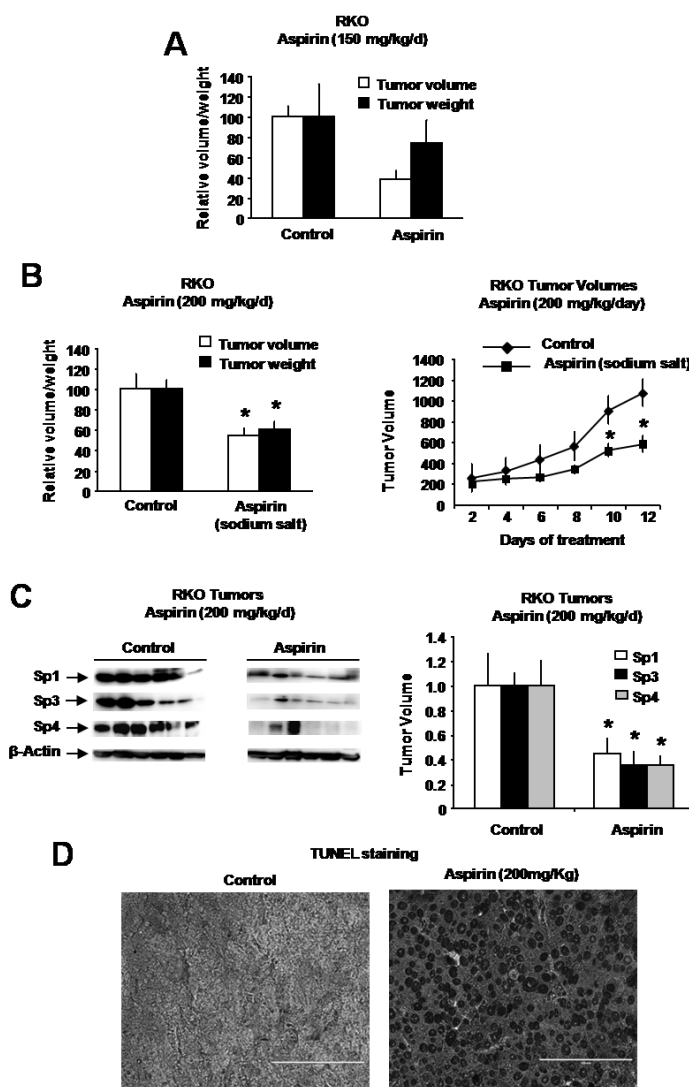

Fig. 2.8. Aspirin inhibits colon tumor growth in athymic nude mice (xenografts). Inhibition of tumor weight (A) and volume (growth) (B) in athymic nude mice administered the sodium salt of aspirin. Athymic nude mice bearing RKO cells as xenografts were treated with the sodium salt of aspirin, and tumor volumes and weights were determined after sacrifice as described in the Experimental Procedures. (C) Expression of Sp1, Sp3 and Sp4 in colon tumors. Tumor lysates from solvent (control) and aspirin-treated mice were analyzed by western blot analysis as described in the Experimental Procedures. Expression of Sp1, Sp3 and Sp4 in aspirin-treated tumors compared to solvent (control)-treated tumors (set at 100%) was determined by densitometry, and β -actin was used to normalize protein expression. Results are means \pm SE (6 replicates) and significant ($p < 0.05$) inhibition of Sp1, Sp3 and Sp4 protein levels by aspirin is indicated (*). (D) Induction of apoptosis. Fixed tumor tissue from control and aspirin-treated mice were analyzed for TUNEL staining as outlined in the Experimental Procedures.

These data confirm that aspirin-mediated inhibition of colon cancer cell and tumor growth was accompanied by downregulation of Sp transcription factors and this response contributes to the anticancer activity of aspirin.

DISCUSSION

Aspirin and other NSAIDs reduce the incidence and increase survival of colon cancer patients and similar results have been observed for aspirin as a chemotherapeutic agent for treatment of breast cancer patients [616-620]. These results indicate that aspirin has significant potential as a chemotherapeutic agent, although there is concern regarding the adverse gastrointestinal side-effects of aspirin [614, 615, 644] and in the future, these may be circumvented by using NO-NSAIDs. The effective doses of aspirin in most *in vitro* studies in colon cancer cells vary from 1-10 mM [485, 621-626] and we observed significant inhibition of SW480, RKO, HT-29 and HCT-116 cell growth at ≤ 2.5 mM aspirin (Fig. 2.1) and 10 mM aspirin completely inhibited cell growth without causing seeded cells to detach. In children with autoimmune disease, treatment with aspirin (25 mg/kg) exhibited maximum serum concentrations of 5.2 mM aspirin with a range of 0.38-10.26 mM [637], suggesting that the dose range of aspirin used in this and many previous studies in colon cancer cells (1-10 mM) is within the range of serum levels achieved in studies using pharmacological doses of aspirin [637]. RNA interference studies in several cancer cell lines show that knockdown of Sp1, Sp3 and Sp4 (singly or in combination) results in decreased expression of growth promoting (EGFR, c-MET, cyclin D1), survival (bcl-2, survivin), angiogenic (VEGF and its receptors), and pro-inflammatory [p65 (NF- κ B)] genes or gene products [628, 631-636]. Moreover, several anticancer agents including NSAIDs and GT-094 (a NO-NSAID), curcumin, betulinic acid and synthetic

triterpenoids, and arsenic trioxide decrease expression of Sp1, Sp3, Sp4 and Sp-regulated genes in cancer cells and these effects contribute to their anticancer activity [627, 628, 630, 645]. The reported growth inhibitory and antiangiogenic activity of aspirin and the downregulation of bcl-2 expression [621-623] suggested that one of the mechanisms of action of aspirin may also be due to downregulation of Sp1, Sp3 and Sp4 transcription factors. Results in Figs 2.1 and 2.2 show that aspirin induced a time- and concentration-dependent downregulation of Sp1, Sp3, Sp4 and Sp-regulated gene products in RKO, SW480, HT-29 and HCT-116 cells. There was some variability among the different cell lines in terms of their sensitivity to aspirin; however, after treatment for 48 hr, downregulation of Sp1, Sp3 and Sp4 was observed at concentrations of aspirin that were ≤ 5 mM (HT-29 and HCT-116 cells) or 5-10 mM (RKO and SW480 cells). These results, coupled with *in vivo* data showing that the sodium salt of aspirin decreased colon tumor growth in a xenograft model (RKO cells) in athymic nude mice and also decreased levels of Sp1, Sp3 and Sp4 proteins in tumors (Fig. 2.7), suggest that aspirin-induced downregulation of Sp proteins plays a role in the anticancer activity of this compound.

Aspirin-induced inhibition of β -catenin and NF κ B have also been associated with the anticancer activity of aspirin [485, 624-626], and we have previously identified that p65-NF- κ B expression was regulated by Sp transcription factors in colon and bladder cancer cells [632, 635]. One study reported that aspirin induced rapid phosphorylation and inactivation of β -catenin within 60 min after treatment and this was accompanied by decreased expression of several putative β -catenin-regulated gene products (e.g. cyclin D1 and c-MET) after treatment for 24-72 hr [624]. Our results confirm that aspirin also decreased expression of β -catenin protein (Fig. 2.4D); however, results of knockdown

of Sp proteins by RNAi showed that β -catenin itself is an Sp-regulated gene, demonstrating that the effects of aspirin on β -catenin are also due to downregulation of Sp proteins.

It was also reported that aspirin increased nuclear p65 levels and induced apoptosis in colon cancer cells within 24 hr after treatment, and this former response has been linked to decreased expression of I κ B α [485, 625, 626]. In contrast, our results show that aspirin treatment had minimal effects on nuclear p65 or p50 levels and the dominant effect was a dramatic decrease in p65 and p50 proteins in whole cell lysates (Figs. 2.4A and 2.4B). RNAi shows that p65 is an Sp-regulated gene (Fig. 2.5B) as previously reported in other cancer cell lines [632, 635]. The maximal (>50%) decrease was only observed in cells transfected with iSp1/3/4 (combined); however, the overall decrease in p65 in this experiment (Fig. 2.5B) was less than observed in other cancer cell lines [632, 635] and aspirin-induced inhibition of NF- κ B was only due, in part, to downregulation of Sp1, Sp3 and Sp4 transcription factors. Thus, although aspirin induces a dramatic downregulation of p65 and p50 in colon cancer cells, Sp protein downregulation contributes to decreased p65 levels, whereas effects on p50 are Sp-dependent. Results of transfection assays with an NF- κ B-luc construct (Fig. 2.5C) also suggest that Sp1, Sp3 and Sp4 differentially affect NF- κ B-dependent transactivation in RKO and SW480 cells and this is currently being investigated.

The NO-NSAID GT-094 also decreased expression of Sp proteins and Sp-regulated genes in RKO and SW480 cells and this was due to induction of ROS and ROS-dependent downregulation of miR-27a and induction of the Sp transcriptional repressor ZBTB10 [627]. These responses were inhibited by antioxidants, whereas aspirin induced Sp downregulation was not affected by antioxidants (Fig. 2.6B);

however, the pan-caspase inhibitor Z-VAD-fmk inhibited aspirin-induced effects on Sp1, Sp3 and Sp4 (Fig. 2.6D). Arsenic trioxide also induced caspase-dependent cleavage of Sp3 and Sp4 in bladder cancer cells [636] and retinoid (CD437)-induced Sp1 degradation was also caspase-dependent in EL-4 cells [646]. It has also been reported that zinc depletion induces apoptosis and decreases Sp1, Sp3 and Sp4 in cancer cell lines [642, 643], and we confirmed that aspirin-induced downregulation of Sp1, Sp3 and Sp4 was inhibited in RKO and SW480 cells cotreated with aspirin plus ZnSO₄ (Fig. 2.7D). The physical interactions of zinc ions with aspirin have previously been observed [647], and functional interactions between zinc ions and aspirin in terms of zinc-induced neurotoxicity and the fetal toxicity have also been reported [648, 649]. Results of this study show a novel pathway for aspirin-induced effects on Sp1, Sp3 and Sp4 in colon cancer cells, and current studies are focused on specific enzymes and pathways associated with the effects of aspirin on zinc homeostasis.

Previous studies on the pharmacokinetics of aspirin (25 mg/kg) administered to children with autoimmune disease showed that maximum serum concentrations of aspirin were 5.20 mM (range of 0.38 - 10.26 mM), whereas the maximum concentration of the major aspirin metabolite salicylate was 172 mM with a range of 59.8-312.2 mM [637]. Thus, pharmacologic doses of aspirin that give low mM serum concentrations can be accompanied by > 30-fold higher concentrations of salicylate which are more than sufficient to inhibit colon cancer cell growth and decrease Sp1, Sp3, Sp4 and Sp-regulated genes (Fig. 2.3). Our studies with salicylate show that both aspirin and salicylate induced similar responses with comparable potencies in colon cancer cells (Figs. 2.1-2.3) and this is consistent with previous reports [615, 622, 623, 650]. The high salicylate/aspirin serum ratios observed in children administered pharmacological doses

of aspirin (25 mg/kg) [637] suggests that the salicylate metabolite may be a major contributor to the reported chemotherapeutic effects of aspirin in colon cancer patients.

In summary, this study demonstrates that aspirin induces caspase-dependent proteolysis of Sp1, Sp3 and Sp4 proteins in colon cancer cells and tumors and, this was accompanied by downregulation of several Sp-regulated genes involved in cell proliferation, survival and angiogenesis. Aspirin-induced Sp downregulation was due to activation of nuclear caspases and perturbation of zinc homeostasis, and the mechanisms that regulate this pathway are unknown and are currently being investigated. Based on the similar effects of aspirin and salicylate as anticancer agents observed in Figs 2.1-2.3 and other studies [615, 622, 623, 650] and the high serum salicylate/aspirin ratios [637], the cancer chemotherapeutic effects of aspirin observed in human cancer studies [615-617, 619, 620] may primarily be due to the salicylate metabolite.

CHAPTER III

TOLFENAMIC ACID (TA) INHIBITS COLON CANCER CELL AND TUMOR GROWTH AND DOWNREGULATES SPECIFICITY PROTEIN (Sp) TRANSCRIPTION FACTORS

INTRODUCTION

Non-steroidal anti-inflammatory drugs (NSAIDs) are used traditionally as inhibitors of pain, fever and inflammation, however, there is evidence that NSAIDs also act as cancer chemopreventive and chemotherapeutic agents [615, 651, 652]. The anticancer activity of acetylsalicylic acid (ASA or aspirin) has been extensively characterized both in epidemiological and laboratory-based studies [408, 419, 615, 652, 653]. Several case-control studies have shown that aspirin use is associated with decreased incidence of several cancers including colon and breast cancer and it has also been reported that aspirin use after diagnosis of colon and breast cancer decreases subsequent recurrence of these cancers [434, 507, 619, 654-657]. NSAIDs such as sulindac induce colon polyp regression in high risk individuals with familial adenomatous polyposis who prematurely develop colon polyps and are a high risk group for colon cancer [427, 658]. Cyclooxygenase-2 (COX-2) inhibitors are also highly promising drugs for treatment of colon cancer, however, their effectiveness is tempered by an increase in adverse cardiovascular side-effects [410, 659].

NSAIDs such as aspirin and COX-2 inhibitors block cyclooxygenase activity and the subsequent production of prostanoids including prostaglandins and thromboxanes which act as inflammatory mediators. However, the mechanisms of action of NSAIDs as anticancer agents are complicated and involve activation of multiple pathways resulting in inhibition of cell growth, survival and angiogenesis [408, 419, 615, 651-653]. Initial

studies in this laboratory showed that the COX-2 inhibitors celecoxib, nimesulide and NS-398 inhibited colon cancer cell growth and induced proteasome-dependent degradation of the specificity proteins (Sp), Sp1 and Sp4 that are overexpressed in these cancer cells [434]. These compounds also decreased expression of vascular endothelial growth factor (VEGF) an Sp-regulated gene and the effects of these COX-2 inhibitors were COX-2-independent [410]. Subsequent screening of different structure classes of NSAIDs in pancreatic cancer cells identified tolfenamic acid as a relatively potent anticancer agent that also induced proteasome-dependent degradation of Sp1, Sp3 and Sp4 in cell lines [518]. TA decreased Sp transcription factors, VEGF and angiogenesis in pancreatic tumors and also inhibited tumor growth and metastasis to the liver in an orthotopic model of pancreatic cancer [518]. TA also inhibits lung, esophageal, breast and ovarian cancer cell growth and with the exception of breast cancer cells, TA also induced downregulation of Sp1, Sp3, Sp4 and Sp-regulated genes [516, 519-522, 524].

Since NSAIDs have been strongly linked to colon cancer chemoprevention and chemotherapy, we have investigated the anticancer activity and mechanism of action of TA in colon cancer cell lines and in nude mice bearing colon cancer cells as xenografts. TA inhibits colon cancer cell and tumor growth and this was accompanied by decreased expression of Sp1, Sp3, Sp4 and Sp-regulated gene products that play a role in cancer cell growth, survival, angiogenesis and inflammation. However, in contrast to studies in pancreatic cancer [518], TA-induced downregulation of Sp transcription factors was proteasome-independent and involved induction of caspase-dependent pathways.

MATERIALS AND METHODS

Cell lines, reagents and antibodies. RKO, SW480, HT-29 and HCT-116 human colon carcinoma cell lines were obtained from American Type Culture Collection (Manassas, VA). RKO and SW480 cells were maintained in Dulbecco's modified/Ham's F-12 (Sigma-Aldrich, St. Louis, MO) with phenol red supplemented with 0.22% sodium bicarbonate, 5% fetal bovine serum, and 10ml/L 100X anti-biotic anti-mycotic solution (Sigma). HT-29 and HCT-116 cells were maintained in McCoy's 5A medium (Sigma-Aldrich, St. Louis, MO) with phenol red supplemented with 0.22% sodium bicarbonate, 10% fetal bovine serum, and 10 ml/L 100X anti-biotic anti-mycotic solution (Sigma). Cells were grown in 150 cm² culture plates in an air/CO₂ (95:5) atmosphere at 37°C and passaged approximately every 3-5 days. All antibodies were purchased from Santa Cruz Biotechnology (Santa Cruz, CA), except cleaved poly (ADP) ribose polymerase (PARP) and c-Met (Cell Signaling Technology, Danvers, MA), Sp1, survivin and VEGF-R2 (Millipore, Temecula, CA), VEGFR1 and P65 (Abcam Inc. Cambridge, MA), and β -actin antibodies (Sigma-Aldrich). The NSAIDs tolfenamic acid, diclofenac and ampiroxicam were purchased from LKT laboratories, Inc. (St. Paul, MN). Glutathione, 98% (γ -glu-cys-gly, GSH), zinc sulphate and lactacystin were purchased from Sigma-Aldrich (St Louis, MO). Dithiothretol (DTT, 98%) was obtained from Boehringer Mannheim Corp, (Indianapolis, IN). Caspase inhibitors 2, 8, 9 and pancaspase inhibitor (Z-VAD-fmk) are purchased from Calbiochem (sandiego, CA). Caspase 12 inhibitor was purchased from BioVision Inc, (Milpitas, CA). Leptomycin B was inhibitor of nuclear export purchased from Enzo Life Sciences International, Inc. (Plymouth Meeting, PA). AM251 and AM630 were purchased from Cayman Chemical Company (Ann Arbor, Michigan) and Tocris Bioscience (Ellisville, MO) respectively. Gliotoxin was kindly

provided by Dr. Alan Taylor (National Research Council of Canada, Halifax, NS, Canada).

Cell proliferation assays. RKO, SW480, HT-29 and HCT-116 colon cancer cell lines were plated (3×10^4 per well) using DMEM:Ham's F-12 medium containing 2.5% charcoal stripped fetal bovine serum (FBS) in 12-well plates and left to attach for 24 hr. Cells were then treated with either vehicle or the indicated concentrations of tolfenamic acid. After 24, 48 and 72 hr of treatment, cells were counted using a Coulter Z1 particle counter. Each experiment was carried out in triplicate and results are expressed as means \pm SE for each determination.

Annexin V staining. Apoptosis, necrotic and healthy cell detection kit was purchased from Biotium, Inc, (Hayward, CA). RKO, SW480, HT-29 and HCT-116 colon cancer cells (7.5×10^4) were seeded in Lab-Tek two chambered cover glass slides and allowed to attach overnight. After treatment with tolfenamic acid (100 μ M) for 24 hr, cells were washed with cold phosphate –buffered saline (PBS) twice and incubated with FITC Annexin V, ethidium homodimer III and Hoechst 33342 in Annexin V binding buffer for 20 min according to the manufacturer's instructions. The cells were then washed twice with Annexin V binding buffer and fluorescence was analyzed with a digital fluorescence microscope.

Western blots. RKO, SW480, HT-29 and HCT-116 colon cancer cells were seeded in DMEM:Ham's F-12 medium containing 2.5% charcoal-stripped FBS and, after 24 hr, cells were treated with either vehicle (DMSO) or the indicated compounds. Cells were collected using high-salt buffer (50 mM HEPES, 0.5 mol/L NaCl, 1.5 mM MgCl₂, 1 mM EGTA, 10% glycerol, and 1% Triton-X-100) and 10 ml/L Protease Inhibitor Cocktail (Sigma-Aldrich). After centrifugation of the lysates at 15,000 g for 15 min at 4°C, the

supernatants were recovered, and protein was quantified by the Bradford protein assay. Protein lysates (15-60 µg) were incubated for 5 min at 100°C along with 5X loading buffer and then separated by electrophoresis on 7.5-12% sodium dodecyl sulphate - polyacrylamide gels at 120 V for 3 to 4 h. Proteins were transferred onto polyvinylidene difluoride membranes by wet electroblotting in a buffer containing 25 mM Tris, 192 mM glycine, and 20% methanol for 1.5 h at 180 mA. Membranes were blocked for 45 min with 5% TBST-Blotto (10 mM Tris-HCl, 150 mM NaCl, pH 8.0, 0.05% Triton X-100, and 5% nonfat dry milk) and incubated in fresh 5% TBST-Blotto with 1:500 primary antibody overnight with gentle shaking at 4°C. After washing twice with TBST for 10 min, the membrane was incubated with secondary antibody (1:5000) in 5% TBST-Blotto for 3-4 hr by gentle shaking. The membrane was washed twice with TBST for 10 min, incubated with 2 ml of chemiluminescence substrate (Millipore, Temecula, CA) for 1 min, and exposed to Kodak image station 4000 mm Pro (Carestream Health, Rochester, NY).

Xenograft studies in athymic mice. Female athymic nude mice were purchased from Harlan Laboratories (Indianapolis, IN). The mice were housed and maintained under specific pathogen-free conditions in facilities approved by the American Association for Accreditation of Laboratory Animal Care and in accordance with current regulations and standards of the United States Department of Agriculture, United States Department of Health and Human Services. The mice were used in accordance with institutional guidelines. To produce tumors, RKO cells were harvested from subconfluent cultures by a brief exposure to 0.25% trypsin and 0.02% ethylenediaminetetraacetic acid. Trypsinization was stopped with medium containing 10% fetal bovine serum, and the cells were washed once in serum-free medium and resuspended in serum free medium.

Only suspensions consisting of single cells with 90% viability were used for the injections. A xenograft was established by subcutaneous injection of the cells (3×10^6) into the flanks of individual mice. Tumors were allowed to grow for 6 days or until they were palpable. Mice were then randomized into two groups of six mice per group and dosed by oral gavage in corn oil or 50 mg/kg/day tolfenamic acid (TA) on every alternate day for 14 days. The mice were weighed, and tumor size was measured every second day with calipers to permit calculation of tumor volumes: $V=LW^2/2$, where L and W were length and width, respectively. After 14 days, the animals were sacrificed; final body and tumor weights were determined and plotted. At the end of the experiment, major visceral organs and tumors were collected and analyzed for Sp protein expression levels using western blots.

Statistical analysis. Statistically significant differences were determined by analysis of variance and Student t-test, and the levels of probability were noted. All statistical tests were two-sided. IC_{50} values were calculated using non-linear regression analysis and expressed in μM , at 95% confidence intervals.

RESULTS

TA induces apoptosis, inhibits colon cancer cell proliferation and decreases expression of Sp1, Sp3 and Sp4 proteins. The effects of tolfenamic acid on growth of colon cancer cells was investigated in SW480, RKO, HCT-116 and HT-29 cell lines (Figs. 3.1A and 3.1B).

After treatment for 72 hr, significant growth inhibition was observed in all cell lines treated with 50-100 μM TA; after 24 hr \leq 100 μM TA also inhibited proliferation of SW480, RKO and HCT-116 but not HT-29 cells which were the most resistant among the four colon cancer cell lines. In addition, treatment of SW480, RKO, HCT-116 and HT-29 cells with 100 μM TA for 24 hr enhanced annexin V staining (Figs. 3.1C and 3.1D) confirming that TA also induced apoptosis in colon cancer cells as previously observed in lung, esophageal and pancreatic cancer cells treated with TA [518, 520, 521]. Treatment of the colon cancer cell lines with TA also induced PARP cleavage and this was accompanied by downregulation of the pro-survival genes bcl-2 and survivin (Figs. 3.2A and 3.2B). Previous studies indicated that bcl-2 and survivin are regulated by Sp1, Sp3 and Sp4 transcription factors that are overexpressed in colon and other cancer cell lines [410, 516, 518-522, 524] and Fig 3.2C and 3.2D demonstrate that TA decreased expression of Sp1, Sp3 and Sp4 proteins in RKO, SW480, HT-29 and HCT-116 cells. Downregulation of Sp1, Sp3 and Sp4 proteins is both time- and dose-dependent and these results are consistent with the reported effects of TA on levels of Sp1, Sp3 and Sp4 proteins in other cancer cell lines [410, 516, 518-522, 524].

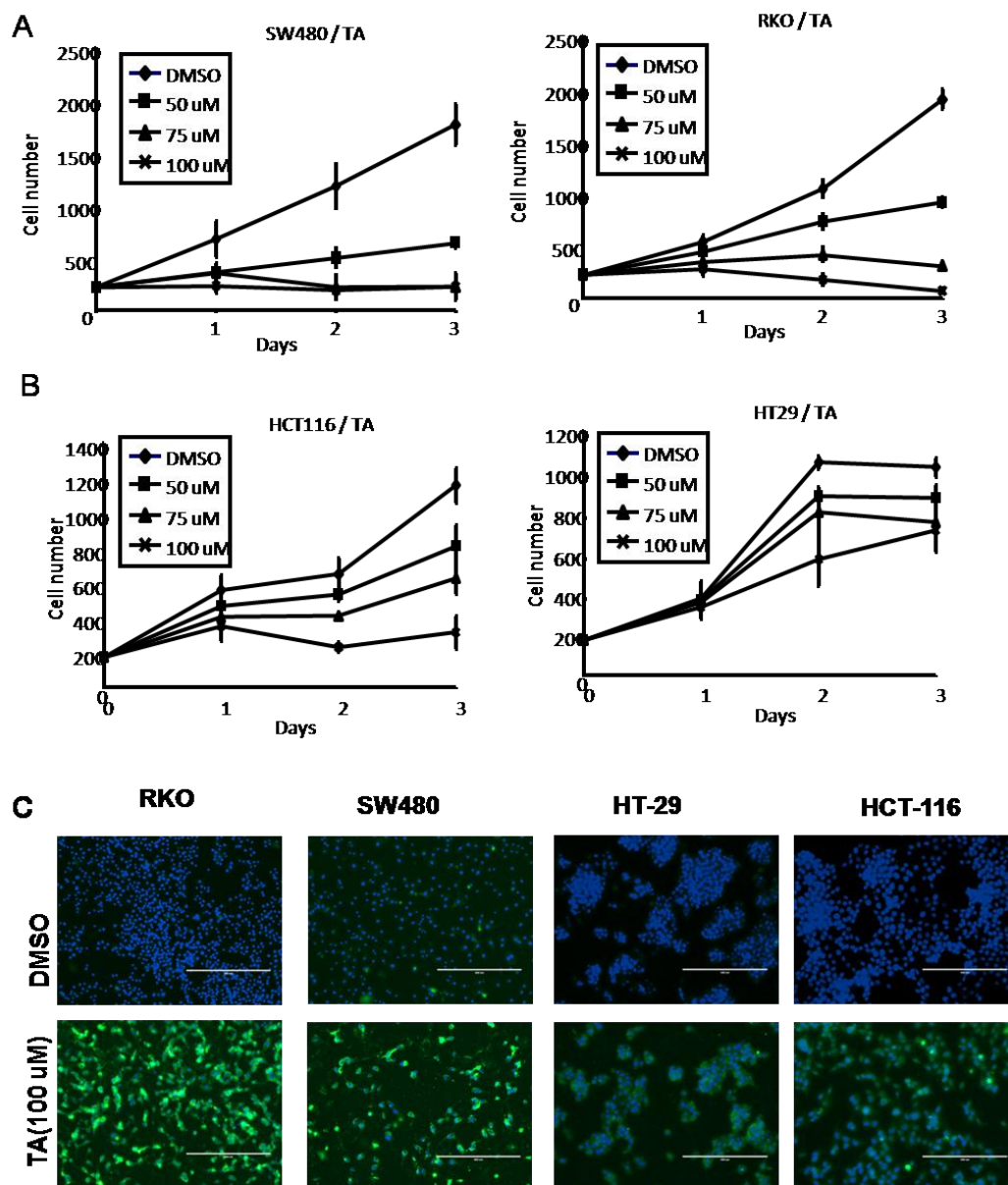

Fig. 3.1. Tolfenamic acid inhibits colon cancer cell growth and induces apoptosis. Inhibition of SW480 and RKO (A) and HCT-116 and H-T29 (B) colon cancer cell proliferation. Cells were treated with DMSO or 50-100 μ M tolfenamic acid for 3 days, and cell numbers were determined as described in the Materials and Methods. C. Induction of Annexin V staining and apoptotic responses in RKO, SW480, HT-29 and HCT-116 cells. Annexin V staining was determined as described in the Materials and Methods. Results in (A) and (B) are means \pm SE for 3 replicate determination for each treatment group, and significant ($p < 0.05$) inhibition is indicated (*).

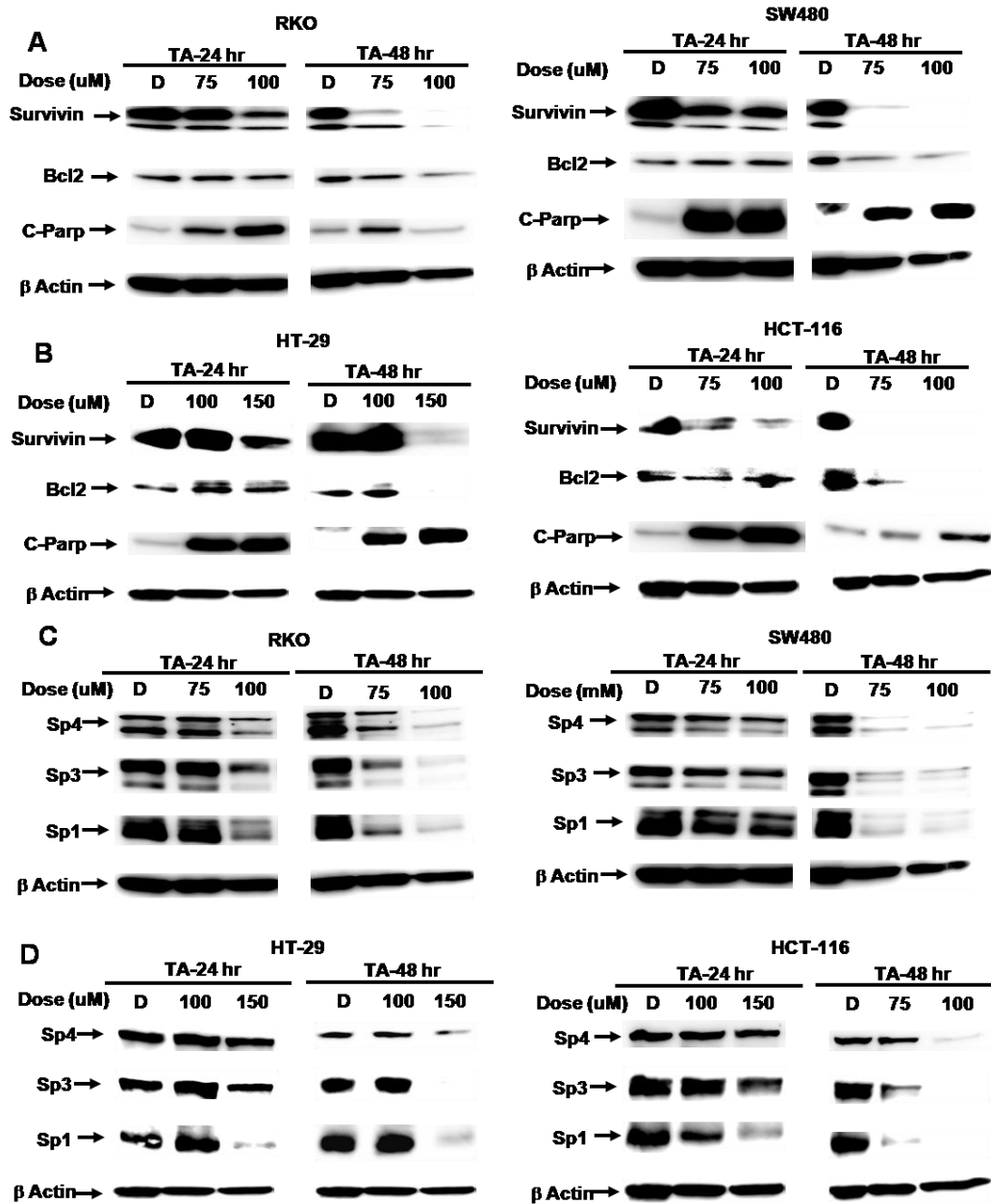

Fig. 3.2. Western blot analysis of Sp-regulated survival and Sp proteins in colon cancer cells. Tolfenamic acid decreases expression of survival proteins (survivin, bcl-2), and increases expression of apoptotic proteins (cleaved PARP) in RKO and SW480 (A), HT-29 and HCT-116 (B) colon cancer cells. Tolfenamic acid decreases the expression of Sp proteins (Sp1, Sp3 and Sp4) in RKO and SW480 (C) and HT-29 and HCT-116 (D) colon cancer cells. Cells were treated with 50 or 100 μ M tolfenamic acid for 24 or 48 hr, and whole cell lysates were analyzed by western blot analysis as described in the Materials and Methods. Results are typical of duplicate experiments.

TA decreases expression of Sp-regulated genes including NF- κ B. Treatment of RKO and SW480 cells with 75 or 100 μ M TA for 24 or 48 hr resulted in a time- and concentration-dependent decrease in several Sp-regulated genes including VEGF, VEGFR1, cyclin D1 and c-MET (Fig. 3.3A). Similar results were observed in HT-29 and HCT-116 cells (Fig. 3.3B) however, it was apparent that HT-29 cell were the most resistant cell line to the effects of TA on downregulation of Sp and Sp-regulated gene products. Since tolfenamic acid is an anti-inflammatory drug and p65 is an Sp-regulated gene (26, 27) we also investigated the effects of TA on p65 and p50 in RKO (Fig. 3.3C) and SW480 (Fig. 3.3D) cells. After treatment of both cell lines with 75 and 100 μ M TA for 24 or 48 hr there was a decrease in both p65 and p50 proteins and this corresponded to decreased NF- κ B-dependent transactivation (data not shown).

TA inhibits colon tumor growth in a xenograft model. The effects of TA (50 mg/kg/day) on colon tumor growth were investigated in athymic nude mice bearing RKO cells as xenografts. TA significantly inhibited tumor volumes over the 3 week period of administration (Fig. 3.4A) and after sacrifice, TA treated mice exhibited significantly lower tumor volumes and weights (Fig. 3.4B) compared to corn oil treated controls. We also examined expression of Sp1, Sp3, Sp4 and Sp-regulated gene products on individual mice by western blot analysis of tumor lysates (Fig. 3.4C). Although there was some interindividual differences in expression of these proteins in the control and treated group (Fig. 3.4C), quantitation of the results relative to β -actin (relative expression in controls was set at 1.0) showed that treatment with TA significantly decreased protein levels of Sp1, Sp3, Sp4 and Sp-regulated genes (Fig. 3.4D).

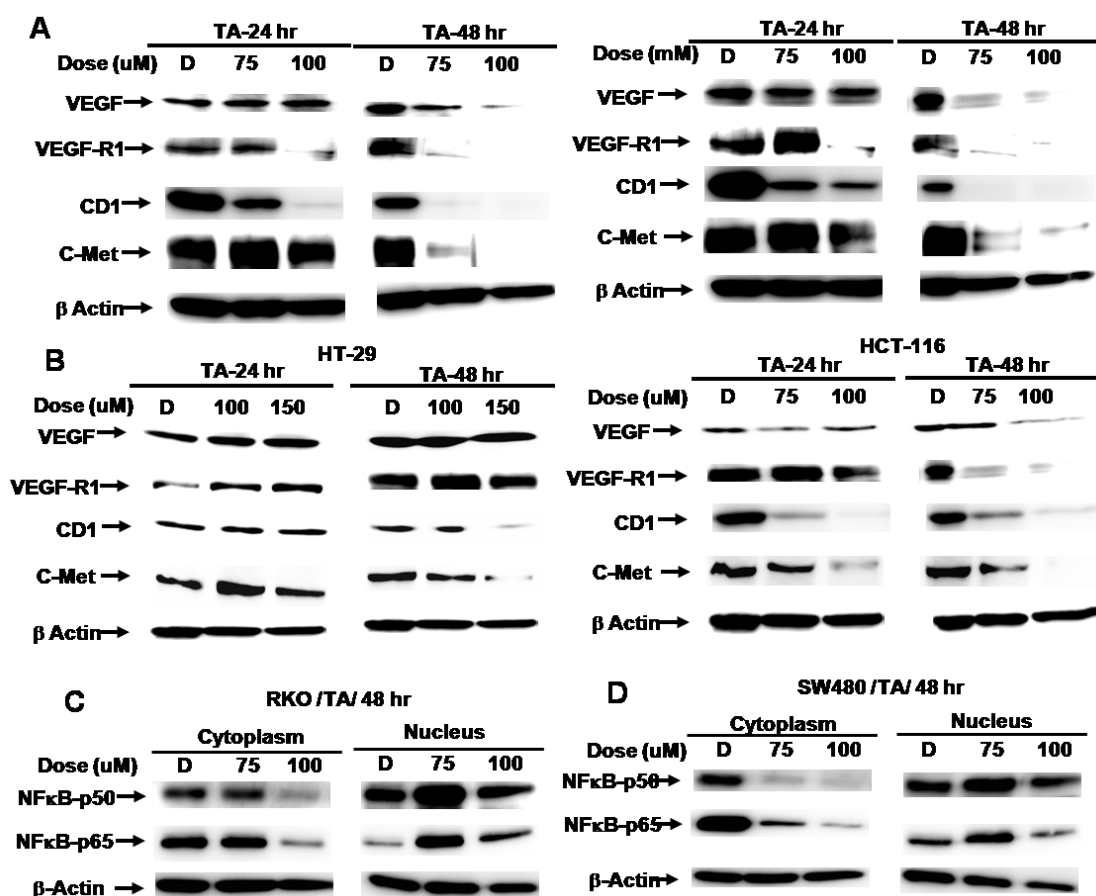

Fig. 3.3. Western blot analysis of Sp-regulated angiogenic and proliferative proteins in colon cancer cells. Tolfenamic acid decreases the expression of angiogenic proteins (VEGF, VEGFR1) and proliferative proteins (cyclin D1, C-Met) in RKO, SW480 (A) and HT-29 and HCT-116 (B) colon cancer cells. Tolfenamic acid decreases the expression of NF-κB (p65 and p50) in RKO and SW480 (C) colon cancer cells. Cells were treated with 50 or 100 μM tolfenamic acid for 24 or 48 hr, and whole cell, nuclear and cytosolic extracts were analyzed by western blot analysis as described in the Materials and Methods. Results are typical of duplicate experiments.

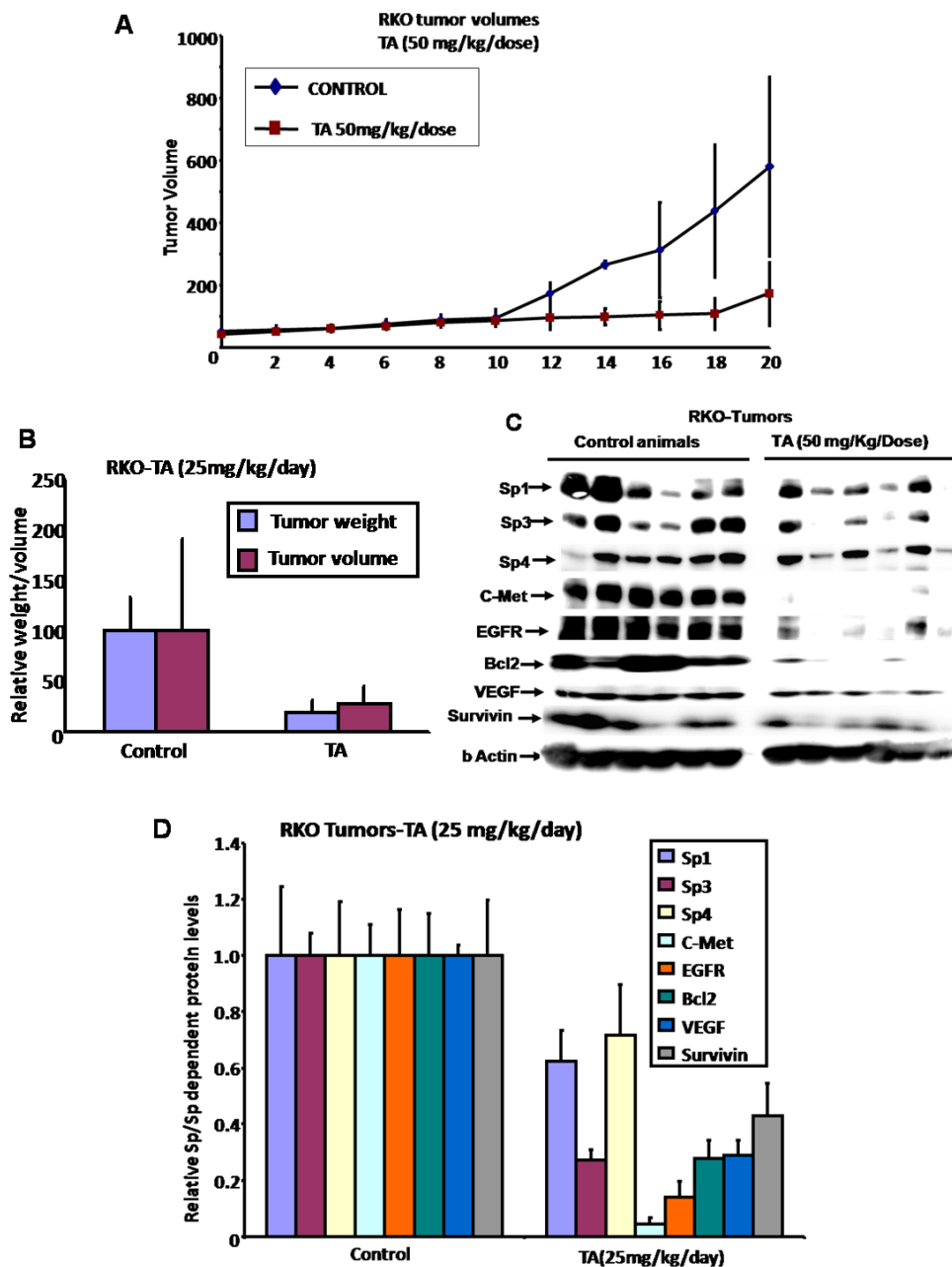

Fig. 3.4. Tolfenamic acid inhibits colon tumor growth in athymic nude mice (xenografts). A, Inhibition of tumor growth in athymic nude mice administered with tolfenamic acid. B, Athymic nude mice bearing RKO cells as xenografts were treated with tolfenamic acid, and tumor volumes and weights were determined after sacrifice as described in the Materials and Methods. (C) Expression of Sp1, Sp3 and Sp4 in colon tumors. Tumor lysates from solvent (control) and tolfenamic acid-treated mice were analyzed by western blot analysis as described in the Materials and Methods. D, Expression of Sp1, Sp3 and Sp4 proteins in tolfenamic acid-treated tumors compared to solvent (control)-treated tumors (set at 100%) was determined by densitometry, and β -actin was used to normalize protein expression. Results are means \pm SE (6 replicates) and significant ($p < 0.05$) inhibition of Sp1, Sp3 and Sp4 protein levels by tolfenamic acid is indicated (*).

Mechanism of TA-induced downregulation of Sp1, Sp3 and Sp4 proteins. TA induces proteasome-dependent downregulation of Sp1, Sp3 and Sp4 in pancreatic cancer cells [518] however, results in Fig. 3.5A show that the proteasome inhibitors lactacystin and gliotoxin did not affect TA-induced downregulation of Sp1, Sp3 or Sp4 proteins in RKO and SW480 cells. Drug-induced ROS also decreased Sp protein expression in several cancer cell lines [572, 660-662], however Fig. 3.5B shows that the antioxidants DTT or GSH did not affect downregulation of Sp1, Sp3 and Sp4 in colon cancer cells treated with 100 μ M TA. These results are in contrast to the effects of antioxidants on Sp downregulation by ROS inducers in colon and other cancer cell lines (pancreatic, bladder). Cannabinoid (CB) receptor agonists also downregulate Sp1, Sp3 and Sp4 and these responses are inhibited by the CB1 and CB2 receptor antagonists AM251 and AM630 respectively [663] however these antagonists did not affect TA-mediated effects on Sp proteins (Fig. 3.5C). Previous studies with arsenic trioxide [662] have also linked activation of caspases to degradation of Sp1, Sp3 and Sp4 and therefore we initially investigated the effects of inhibitors of caspases 2, 8 and 9 and the pan-caspase inhibitor Z-VAD-fmk on TA-mediated degradation of Sp proteins (Fig. 3.6A). In RKO cells only the pan-caspase inhibitor Z-VAD-fmk blocked TA-induced degradation of Sp1, Sp3 and Sp4 and in a second experiment the caspase-12 inhibitor was also active as an inhibitor in RKO cells (figure/data not shown). In contrast, TA-induced degradation of Sp1, Sp3 and Sp4 in SW480 cell was inhibited not only by Z-VAD-fmk but also inhibitors of caspases 2, 8, 9 and 12 (Fig. 3.6B).

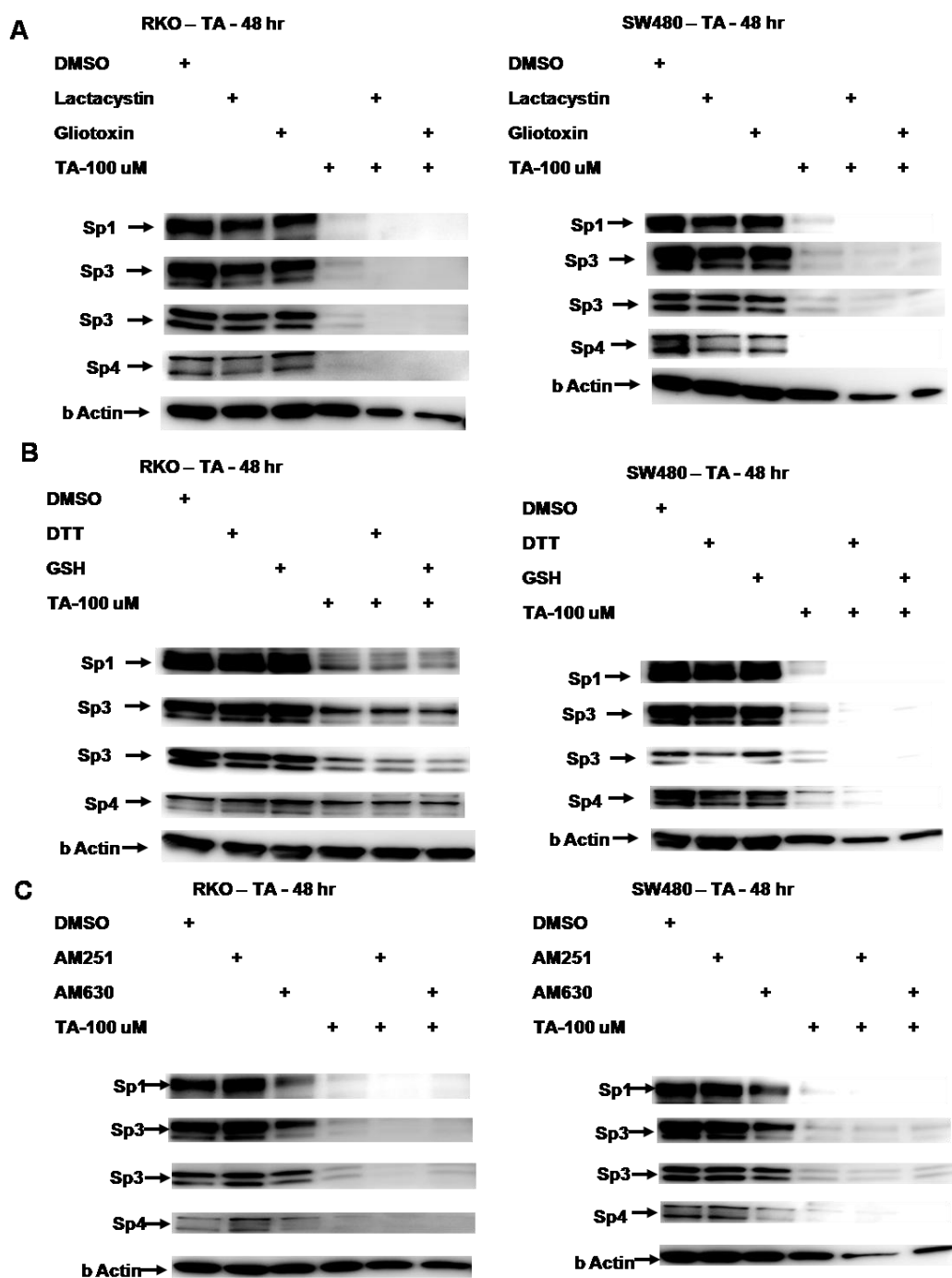

Fig. 3.5. Mechanisms of tolfenamic acid -induced Sp protein degradation. Effect of proteasome inhibitors (A), antioxidants (B) and cannabinoid receptor inhibitors (C) on tolfenamic acid-induced Sp protein downregulation. Cells were treated with DMSO, tolfenamic acid alone or in combination with proteasome inhibitors or antioxidants or cannabinoid receptor inhibitors, and after 48 hr, whole cell lysates were analyzed by western blots analysis as described in the Materials and Methods.

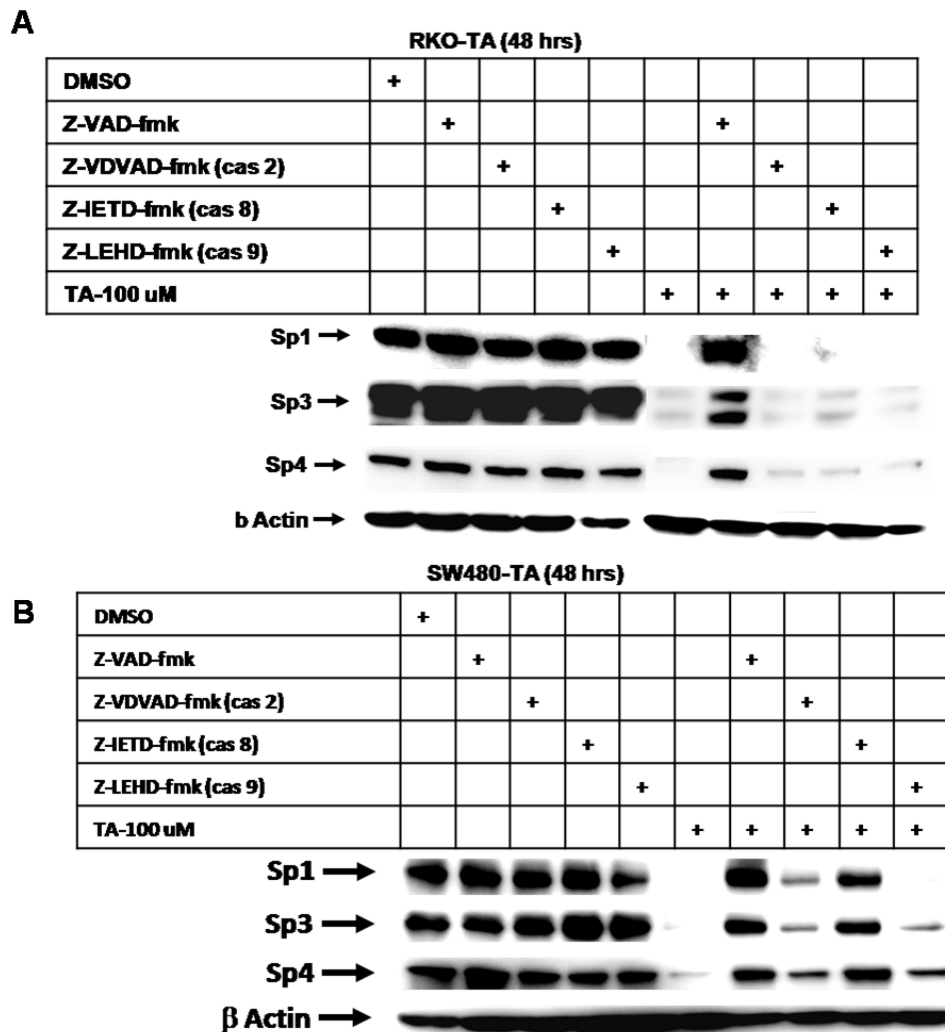

Fig. 3.6. Mechanisms of tolfenamic acid-induced Sp protein degradation. Effects of caspase inhibitors (A, B) on tolfenamic acid-induced Sp protein downregulation. Cells were treated with DMSO, tolfenamic acid alone or in combination with caspase inhibitors, and after 48 hr, whole cell lysates were analyzed by western blot analysis as described in the Materials and Methods. Effects of leptomycin B (B) on tolfenamic acid-induced Sp protein downregulation. Cells were treated with 100 uM tolfenamic acid in the presence or absence of leptomycin B for 48 hr, and cytoplasmic and nuclear lysates were analyzed by western blot analysis as described in the Materials and Methods. Effects of ZnSO₄ (D) on tolfenamic acid-induced Sp protein downregulation. Cells were treated with DMSO, tolfenamic acid alone or in combination with ZnSO₄, and after 48 hr, whole cell lysates were analyzed by western blot analysis as described in the Materials and Methods.

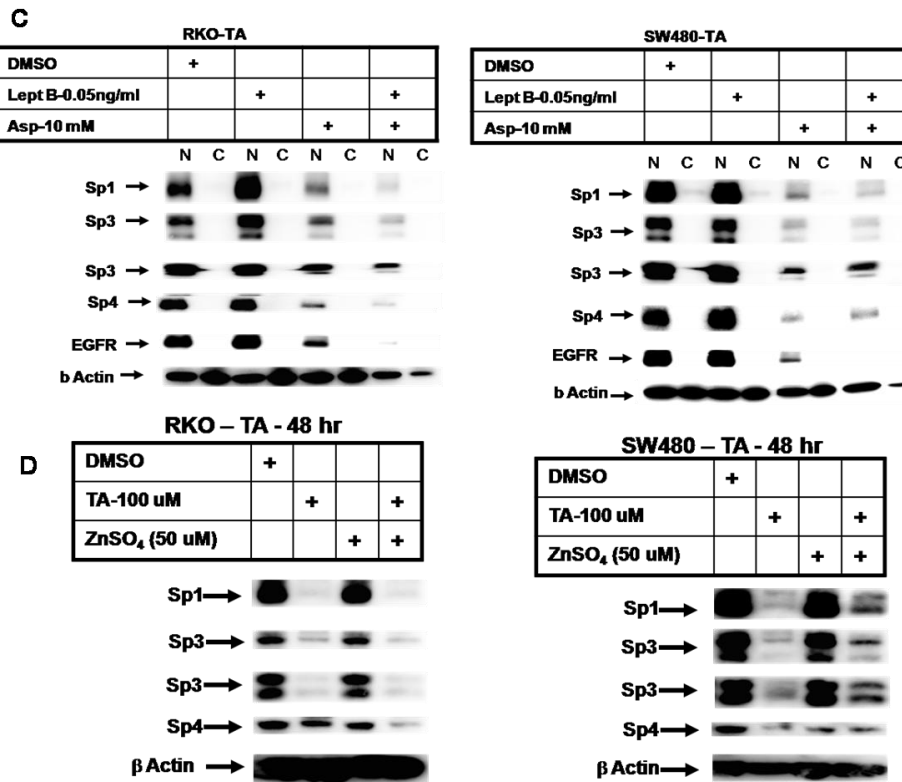

Fig. 3.6. Continued.

Previous studies show that retinoid-induced transglutaminase-2 (TG2) and caspase-3 resulted nuclear TG2-Sp1 crosslinking and subsequent degradation of Sp1 [664] and in this study we also observed that TA-induced degradation of nuclear Sp1, Sp3 and Sp4 (Fig. 3.6C). Moreover, similar results were observed in the presence or absence of leptomycin β (LMB, nuclear protein export inhibitor), confirming that Sp protein degradation was nuclear. However, we did not observe formation of any high molecular weight Sp1/Sp3/Sp4-TG2 crosslinked bands and the detection of subsequent Sp degradation products was inconsistent (data not shown). It has also been reported that zinc chelation induces caspase-dependent cleavage of Sp1, Sp3 and Sp4 which is-

reversed by excess zinc sulfate (ZnSO_4) [665] and Fig. 3.6D shows that ZnSO_4 only partially inhibits TA-mediated Sp degradation in SW480 and not in RKO cells. Current studies are focused on further investigation of the mechanism of caspase induction by TA and the subsequent mechanism identification of specific amino acid targets in Sp1, Sp3 and Sp4 that are required for degradation.

DISCUSSION

Sp1, Sp3 and Sp4 transcription factors are highly expressed in cancer cells and tumors [516, 519-522, 524, 632, 660, 661] and studies focused on Sp1 show that this protein is a negative prognostic factor for pancreatic and gastric cancer patient survival [666, 667]. Sp1 expression is also critical for malignant transformation of human fibroblast cells [373] and expression of Sp1 in rodents and humans decrease with age [367, 668]. The high tumor/non-tumor ratio of Sp1 and other Sp transcription factor suggests that these transcription factors are potentially important drug targets for cancer chemotherapy. Knockdown of Sp1, Sp3 and Sp4 alone or in combination by RNAi also decreased expression of several genes involved in cancer cell growth (cyclin D1, C-MET, EGFR), survival (bcl-2 and survivin), angiogenesis (VEGF and VEGF receptors), and inflammation (p65, NF- κ B) [375, 520, 632, 641, 660-662, 669, 670], and many of these genes are themselves individual targets for anticancer drugs. Moreover, knockdown of Sp transcription factors by RNAi in cancer cells alone also induces apoptosis and growth inhibition [660-662]. Studies in this laboratory have identified several anticancer agents such as curcumin, arsenic trioxide, betulinic acid and synthetic triterpenoids and non-steroidal antiinflammatory drugs (NSAIDs) that act, in part, by downregulating Sp1, Sp3, Sp4 and Sp-regulated genes [375, 518, 572, 632, 641, 660-663, 669, 670].

Several reports show that TA inhibits cancer cell and tumor growth of multiple tumor types and these responses are due, in part, to downregulation of Sp1, Sp3, Sp4 and Sp-regulated genes [516, 518-522, 524]. In this study we have also demonstrated the effectiveness of TA as an inhibitor of colon cancer cell (Fig. 3.1) and tumor growth (Fig. 3.4) and as an inducer of apoptosis (Fig. 3.1C). Moreover these responses are consistent with TA-mediated effects on decreased expression of Sp1, Sp3 and Sp4 and also decrease levels of growth promoting (CD1, c-MET), angiogenic (VEGF and VEGFR) survival (survivin and bcl-2) and inflammatory (p65/p50) genes (Figs. 3.2 and 3.3). Results of this study with TA in colon cancer cells are similar to comparable studies with TA in other cell lines however, the mechanism of TA-induced effects on Sp protein expression differed from previous reports. For example, the proteasome inhibitors gliotoxin and lactacystin did not inhibit TA-induced degradation of Sp1, Sp3 and Sp4 as previously reported in pancreatic cancer cells [518]. Several proteasome-independent pathways for drug-induced repression of Sp1, Sp3 and Sp4 have previously been reported and include ROS-, CB receptor- and caspase-dependent pathways which vary with respect to the drug and cell context [572, 632, 641, 660-663, 669, 670]. For example, betulinic acid-mediated downregulation of Sp1, Sp3 and Sp4 was proteasome-dependent in LNCaP prostate cancer cells [671], ROS-dependent in RKO and SW480 colon cancer cells [641] and we recently showed that in breast cancer cells betulinic acid-induced responses were CB receptor-dependent [663]. TA-induced downregulation of Sp1, Sp3 and Sp4 proteins was not affected by antioxidants (Fig. 3.5B) or CB receptor antagonists (Fig. 3.5C) however, the pan-caspase inhibitor Z-VAD-fmk inhibited TA-mediated degradation of Sp proteins in both RKO and SW480 cells (Figs. 3.6A and 3.6B). We also observed that the caspase-12 inhibitor (Z-ATAD-

FMK) reversed the effects of TA in both cell lines whereas the caspase-2, 8 and 9 inhibitors were active only in SW480 but not RKO cells indicating some mechanistic differences between the two cell lines.

It has previously been reported that induction of TG2 and caspase-3 leads to crosslinking of TG2 with Sp1 and the subsequent proteolytic cleavage of Sp1 [664]. We observed that TA decreased expression of nuclear Sp1, Sp3 and Sp4 in the presence or absence of leptomycin B, the nuclear export inhibitor (Fig. 3.6C) indicating that caspase-dependent cleavage of Sp proteins was primarily nuclear. However, we did not observe induction of TG2 by TA in RKO or SW480 cells nor did we detect any higher molecular weight crosslinked bands (data not shown). Another possible caspase-dependent degradation pathway for Sp1, Sp3 and Sp4 involves zinc chelation which can be rescued by adding excess $ZnSO_4$ [665] and ongoing studies in this laboratory indicate that other NSAIDs induce Sp protein degradation through this pathway. Fig. 3.6D shows that $ZnSO_4$ only partially rescues SW480 cells from TA-mediated degradation of Sp1, Sp3 and Sp4 suggesting that other mechanisms of caspase activation are induced by TA in colon cancer cells and these are currently being investigated.

In summary, results of this study demonstrate the anticancer activity of TA in colon cancer cells and the potential clinical utility of using this drug for chemotherapy (alone or in combination) of colon cancer patients. TA has previously been used for pain relief and as an antiinflammatory agent in human studies [671, 672] and can be readily adapted for clinical applications. TA induces proteasome-dependent and independent degradation of Sp1, Sp3 and Sp4 and for the first time we have demonstrated that activation of caspases by TA is required for Sp protein degradation and current studies

are focused on identifying the mechanisms of TA-induced caspase activation that is required for degradation of Sp1, Sp3 and Sp4.

CHAPTER IV

GT-094, A NO-NSAID, INHIBITS COLON CANCER CELL GROWTH BY ACTIVATION OF A REACTIVE OXYGEN SPECIES (ROS)-MICRORNA-27A:ZBTB10-SPECIFICITY PROTEIN (Sp) PATHWAY

INTRODUCTION

Aspirin and other nonsteroidal anti-inflammatory drugs (NSAIDs) are invaluable for treatment of fever, pain, arthritis, other inflammatory diseases, and cancer, and applications for these compounds continues to increase [419, 615, 655, 673]. Several epidemiology studies have reported decreased incidence of multiple cancers associated with NSAIDs (primarily aspirin) intake, and these drugs have been extensively investigated for their chemopreventive and chemotherapeutic activities [419, 507, 655]. A recent study reported that aspirin use among women with breast cancer decreased the subsequent incidence of metastasis and cancer-related deaths [507]. Aspirin and other NSAIDs play a role in colon cancer prevention and therapy [417, 434, 656, 657, 674-678], and specific NSAIDs and other cyclooxygenase (COX) inhibitors also decrease the risk of colon cancer among high risk individuals [676-678].

Nitric oxide (NO) plays an important role in the suppression of GI-induced inflammation and toxicity, and this has led to development of nitro-NSAIDs (NO-NSAIDs) which combine the anti-inflammatory activities of NSAIDs with the NO-dependent protection from NSAID-induced GI toxicity. NO-aspirin and other NO-NSAIDs exhibit anticancer activity in a wide range of cancer cell lines and *in vivo* models [468, 531, 538, 544, 547, 553, 560, 563, 570, 679-682], and these compounds are invariably more

potent than their corresponding NSAID analogs. For example, the NO-NSAID analog 2-(acetyloxybenzoic acid 4-nitrooxymethyl)-phenyl ester (NO-ASA) is 700 times more potent than aspirin as an inhibitor of pancreatic cancer cell growth which is due to inhibition of cell proliferation and induction of apoptosis by both compounds [547]. The mechanism of action of NO-NSAIDs as cancer chemotherapeutic agents is unclear; however, these compounds clearly inhibit cancer and tumor cell growth, induce apoptosis, and exhibit antiangiogenic and antimetastatic activity.

Ethyl 2-((2,3-bis(nitrooxy)propyl)disulfanyl)benzoate (GT-094) [563, 570] is a novel NO chimera containing an NSAID and NO moieties and also a disulfide pharmacophore that in itself exhibits cancer chemopreventive activity [566]. GT-094 significantly decreases aberrant crypt foci, proliferation and inducible NO synthase (iNOS) levels in azoxymethane-induced rat colon cancer [570] and decreases proliferation and arrests Caco-2 colon cancer cells in the G2/M phase of the cell cycle [563, 570].

In this study, we investigated the mechanism of action of NO-NSAIDs using GT-094 as a model in RKO and SW480 colon cancer cells. GT-094 inhibited colon cancer cell proliferation and induced apoptosis, and this was accompanied by downregulation of genes associated with cell growth [cyclin D1, hepatocyte growth factor receptor (c-Met), epidermal growth factor receptor (EGFR)], survival (bcl-2, survivin), and angiogenesis [vascular endothelial growth factor (VEGF) and its receptors (VEGFR1 and VEGFR2)]. Previous RNA interference studies in this laboratory has shown that all of these genes are regulated, in part, by specificity protein (Sp) transcription factors Sp1, Sp3 and Sp4 that are overexpressed in colon and other cancer cell lines [45, 46, 410, 518, 632, 670, 671, 683, 684]. GT-094 also decreased Sp1, Sp3 and Sp4 in colon

cancer cells and this was dependent on a decrease in mitochondrial membrane potential (MMP) and induction of reactive oxygen species (ROS). ROS-mediated repression of Sp and Sp-dependent genes involves downregulation of microRNA-27a (miR-27a) and induction of ZBTB10, an Sp repressor, and comparable results have also been observed for synthetic triterpenoid anticancer drugs in pancreatic and colon cancer cells [661, 683].

MATERIALS AND METHODS

Cell lines, reagents and antibodies. RKO and SW480 human colon carcinoma cell lines were obtained from American Type Culture Collection (Manassas, VA). RKO and SW480 cells were maintained in Dulbecco's modified/Ham's F-12 (Sigma-Aldrich, St. Louis, MO) with phenol red supplemented with 0.22% sodium bicarbonate, 5% fetal bovine serum, and 10 ml/L 100X antibiotic antimycotic solution (Sigma). Cells were grown in 150 cm² culture plates in an air/CO₂ (95:5) atmosphere at 37°C and passaged approximately every 3-5 days. GT-094 was synthesized in the laboratory of Dr. Gregory R. Thatcher (University of Illinois, Chicago). All antibodies were purchased from Santa Cruz Biotechnology (Santa Cruz, CA), except cleaved poly (ADP) ribose polymerase (PARP) and c-Met (Cell Signaling Technology, Danvers, MA), Sp1 and VEGFR2 (Millipore, Temecula, CA), survivin (R&D Systems, Minneapolis, MN), VEGFR1 (Abcam Inc. Cambridge, MA), and β -actin antibodies (Sigma-Aldrich). Glutathione, 98% (γ -glu-cys-gly, GSH) and carbonyl cyanide 3-chlorophenylhydrazone (CCCP) were purchased from Sigma-Aldrich. Dithiothreitol (DTT, 98%) was obtained from Boehringer Mannheim Corp, (Indianapolis, IN). CM-H₂DCFDA was purchased from Invitrogen. MG132 and lactacystin are the proteasomal inhibitors purchased from Calbiochem (Sandiego, CA) and Sigma Chemicals Co. (St Louis, MO), respectively.

Cell proliferation assays. RKO and SW480 cancer cell lines were plated (3×10^4 per well) using DMEM:Ham's F-12 medium containing 2.5% charcoal stripped fetal bovine serum (FBS) in 12-well plates and left to attach for 24 h. Cells were then treated with either vehicle or the indicated concentrations of GT-094. After 24, 48 and 72 h of treatment, cells were counted using a Coulter Z1 particle counter [377]. Each experiment was carried out in triplicate and results are expressed as means \pm SE for each determination.

Western blots. RKO and SW480 cancer cells were seeded in DMEM:Ham's F-12 medium containing 2.5% charcoal-stripped FBS and, after 24 h, cells were treated with either vehicle (DMSO) or the indicated compounds. Cells were collected using high-salt buffer (50 mM HEPES, 0.5 mol/L NaCl, 1.5 mM MgCl₂, 1 mM EGTA, 10% glycerol, and 1% Triton-X-100) and 10 ml/L Protease Inhibitor Cocktail (Sigma-Aldrich). Protein lysates were incubated for 3 min at 100°C before electrophoresis and then separated on 10% SDS-polyacrylamide gel electrophoresis 120 V for 3 to 4 h. Proteins were transferred onto polyvinylidene difluoride membranes by wet electroblotting in a buffer containing 25 mM Tris, 192 mM glycine, and 20% methanol for 1.5 h at 180 mA. Membranes were blocked for 30 min with 5% TBST-Blotto (10 mM Tris-HCl, 150 mM NaCl, pH 8.0, 0.05% Triton X-100, and 5% nonfat dry milk) and incubated in fresh 5% TBST-Blotto with 1:500 primary antibody overnight with gentle shaking at 4°C. After washing with TBST for 10 min, the polyvinylidene difluoride membrane was incubated with secondary antibody (1:5000) in 5% TBST-Blotto for 2 h by gentle shaking. The membrane was washed with TBST for 10 min, incubated with 6 ml of chemiluminescence substrate for 1 min, and exposed to Kodak image station 4000 mm Pro (Carestream Health, Rochester, NY).

ROS estimation. Cellular ROS levels were evaluated with the cell permeant probe CM-H₂DCFDA (5-(and-6)-chloromethyl-2',7' dichlorodihydrofluorescein diacetate acetyl ester). CM-H₂DCFDA is nonfluorescent until removal of the acetate groups by intercellular esterases and oxidation occurs within the cell. Following treatment of the cells for 12 h, 48-well cell culture plates were loaded with 10 μ M CM-H₂DCFDA for 30 min, washed once with serum-free medium, and analyzed for ROS levels using Bio Tek Synergy 4 plate reader (Bio Tek Instruments, Inc., Winooski, VT) set at 480 nm and 525 nm excitation and emission wavelength, respectively. Cells were then washed twice with PBS and fixed with methanol for 3 min at room temperature. Methanol was then completely removed and 1 mg/ml Janus green was added to the cultures for 3 min. Following removal of Janus green, cultures were washed twice with PBS and 100 μ l of 50% methanol was added to each well. Cell counts were then determined with the plate reader set to an absorbance of 654 nm, and ROS intensities were corrected accordingly. Three experiments were performed and analyzed on different days using 8 wells per treatment group, and results are expressed as means \pm SE for each determination.

Terminal deoxyribonucleotide transferase-mediated nick-end labeling (TUNEL) assay. RKO and SW480 cells (10×10^4) were seeded in two-chambered glass slides and left overnight to attach. After treatment with indicated compounds for 12 h, the *in situ* cell death detection POD kit was used for the terminal deoxyribonucleotide transferase-mediated nick-end labeling (TUNEL) assay according to the instructions in the protocol manual for fixed cells. The percentage of apoptotic cells was calculated by counting the stained cells in eight fields, each containing 50 cells. The total number of apoptotic cells was plotted as a percentage in both cell lines.

Measurement of MMP. MMP was measured with the Mitochondrial Membrane Potential Detection Kit (Stratagene, Cedar Creek, TX) according to manufacturer's protocol using JC-1 dye. RKO and SW480 colon cancer cells were plated on two-well Lab-Tex Coverglass slides (NUNC A/S, Roskilde, Denmark) and, after 24 h, cells were treated with DMSO, CCCP (25 $\mu\text{mol/L}$), GT-094 (50 $\mu\text{mol/L}$) alone or with GSH (5 mmol/L) for 12 h. Cells were then incubated with 1 \times JC-1 dye at 37°C for 15 min and washed twice with assay buffer according to manufacturer's protocol, and then cells were subjected to microscopic analysis using Zeiss Stallion Dual Detector Imaging System (Carl Zeiss Microimaging Inc., Thornwood, NY). J-aggregates are detected as red fluorescence, and J-monomers are detected as green fluorescence. The ratio of red fluorescence to green fluorescence was measured using ImageJ Software. Cells were examined in more than 10 fields per slide on multiple slides. Data represent the average of all the fields and results are expressed as means \pm SE for each determination.

Quantitative real-time PCR analysis of mRNAs and miRNAs. miRNA was extracted using the mirvaRNA extraction kit (Applied Biosystems). Quantification of miRNA (RNU6B, miRNA-27a) was performed using the Taqman miRNA kit (Applied Biosystems) according to the manufacturer's protocol with real-time PCR. U6 small nuclear RNA was used as a control to determine relative miRNA expression. Total RNA was isolated using the RNeasy Protect Mini kit (Qiagen) according to the manufacturer's protocol. RNA was reverse transcribed using Superscript II reverse transcriptase (Invitrogen) according to the manufacturer's protocol. PCR was carried out with the SYBR Green PCR Master Mix from PE Applied Biosystems on an ABI Prism 7700 Sequence Detection System (PE Applied Biosystems) using 0.5 $\mu\text{mol/L}$ of

each primer and 2 μ l cDNA template in each 25 μ l reaction. TATA binding protein (TBP) was used as an exogenous control to compare the relative amount of target gene in different samples. The PCR profile was as follows: one cycle of 95°C for 10 min, then 40 cycles of 95°C for 15 s, and 60°C for 1 min. The comparative CT method was used for relative quantitation of samples, and results are expressed as means \pm SE for at least 3 separate determinations. Primers were purchased from Integrated DNA Technologies. The following primers were used.

TBP (F): 5'-TGACACAGGAGCCAAGAGTGAA-3'

TBP (R): 5'-CACATCACAGCTCCCCACCA-3'

ZBTB10 (F): 5'-GCTGGATAGTAGTTATGTTGC-3'

ZBTB10 (R): 5'-CTGAGTGGTTTGATGGACAGA-3'

Statistical analysis. Statistical significance of differences was determined by analysis of variance and student t-test, and the levels of probability were noted. All statistical tests were two-sided. IC_{50} values were calculated using non-linear regression analysis and expressed in μ M, at 95% confidence intervals.

RESULTS

GT-094 is a model nitro-NSAID analog (NO-chimera) that contains both the aliphatic nitro group and a disulfide linker, and this compound exhibits cancer chemoprevention activity in an *in vivo* model for colon cancer. In this study, we initially investigated the concentration and time-dependent effects of GT-094 on proliferation of RKO and SW480 colon cancer cells (Fig. 4.1A). Significant growth inhibition was observed in both cell lines and the 24-h IC₅₀ values for growth inhibition were 36 and 44 $\mu\text{mol/L}$ in RKO and SW480 cells, respectively. In addition, the proapoptotic effects were examined in RKO and SW480 cells, and GT-094 induced caspase-dependent PARP cleavage in both cell lines (Fig. 4.1B). GT-094 decreased expression of pro-survival survivin and bcl-2 proteins, and this was consistent with the observed caspase-dependent PARP cleavage. GT-094 inhibited cell proliferation and induced apoptosis in RKO and SW480 cells and therefore, the effects of GT-094 on gene products associated with cell proliferation and apoptosis were also investigated. Results in Fig. 4.1C show that GT-094 decreased expression of several proteins involved in cell proliferation and these included cyclin D1, c-Met and EGFR in both RKO and SW480 cells. In addition, we observed that GT-094 decreased expression of the angiogenic growth factor VEGF and its receptor VEGFR1 in RKO and SW480 cells (Fig. 4.1D).

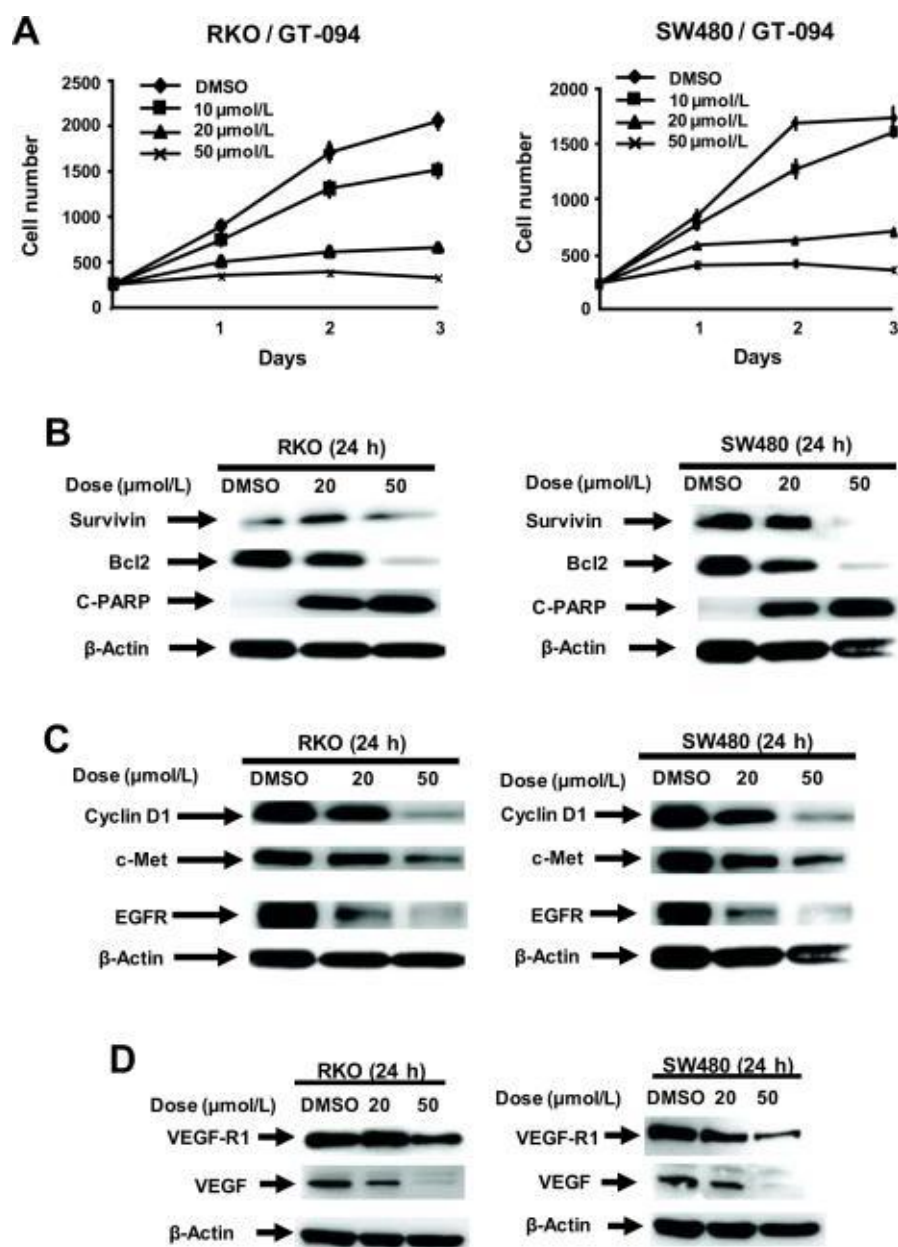

Fig. 4.1. GT-094 inhibits growth and induces apoptosis in colon cancer cells. (A) Inhibition of RKO and SW480 cell growth. Cells were treated with different concentrations of GT-094, and cell numbers were determined on days 1, 2 and 3 as described in the Materials and Methods. Western blot analysis of Sp-regulated survival (B), proliferative (C), and angiogenic (D) gene products in RKO and SW480 cells treated with GT-094. Cells were treated with GT-094 (20 and 50 μmol/L) for 24 h, and whole cell lysates were analyzed by western blots as described in the Materials and Methods.

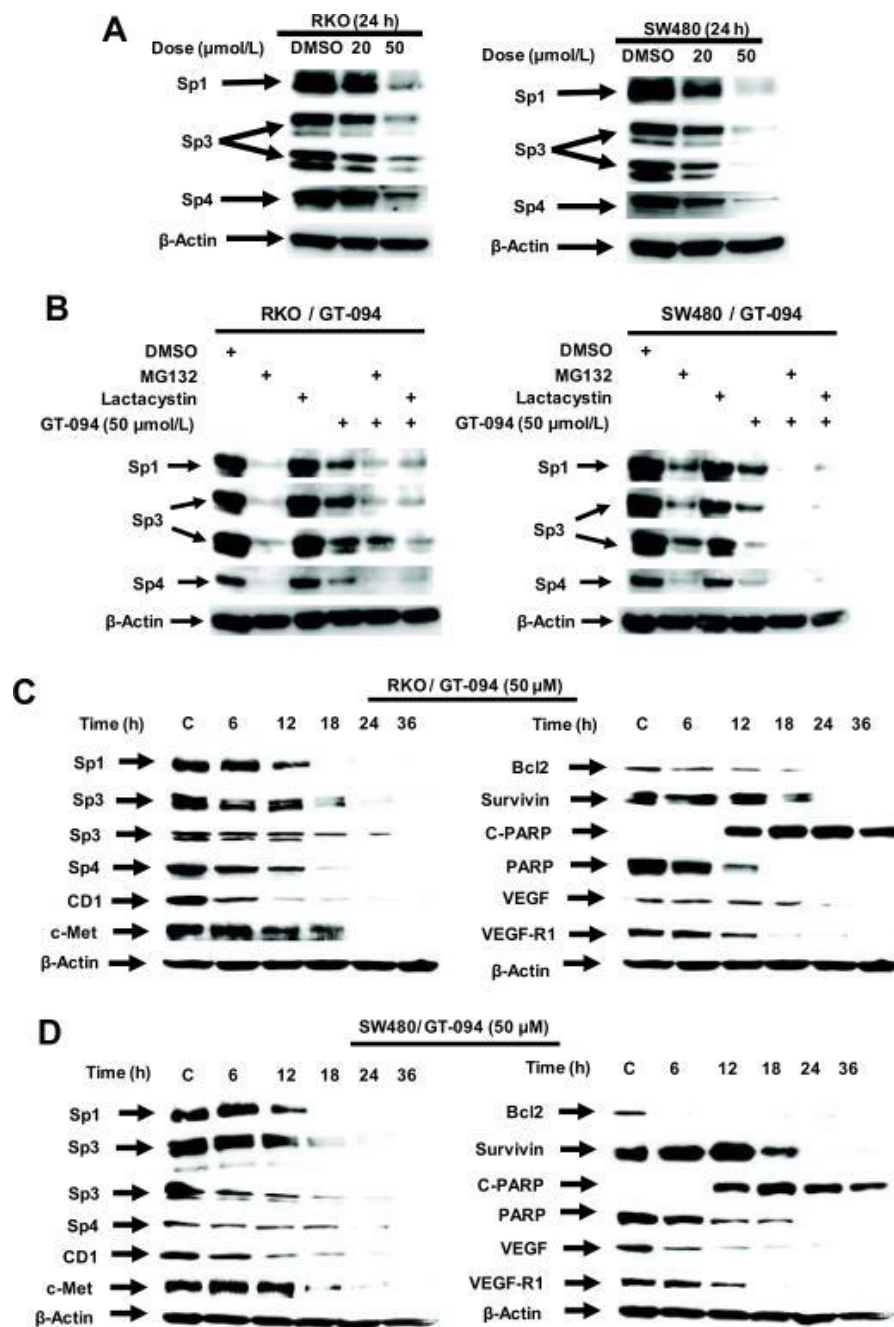

Fig. 4.2. GT-094-mediated effects on Sp protein and Sp-regulated gene products. (A) GT-094 decreases Sp1, Sp3 and Sp4 protein expression in colon cancer cells. RKO and SW480 cells were treated with 20 or 50 μ mol/L GT-094 for 24 h, and whole cell lysates were analyzed by western blots as described in the Materials and Methods. (B) Effects of proteasome inhibitors on Sp downregulation. Cells were treated with 50 μ mol/L GT-094, MG132 or lactacystin alone or in combination, and whole cell lysates were analyzed by western blots as described in the Materials and Methods. Results in Figure 2 are typical of replicate (at least 2) experiments. Time-course effects of GT-094 (50 μ M) in RKO (C) and SW480 (D) cells. Cells were treated with DMSO (0 time) or GT-094 for 6, 12, 18, 24 and 36 h, and whole cell lysates were analyzed by western blots as outlined in the Materials and Methods.

Previous studies with agents such as curcumin, betulinic acid, synthetic triterpenoid anticancer drugs, and the NSAID tolfenamic acid show that these compounds decrease expression of bcl-2, survivin, c-Met, EGFR, cyclin D1, VEGF and VEGFR1 protein in several cancer cell lines, including colon cancer cells, and RNA interference studies confirmed that these genes are regulated by Sp1, Sp3 and Sp4 transcription factors which are overexpressed in cancer cells [518, 632, 661, 670, 671, 683]. Treatment of RKO and SW480 cancer cells with 20 and 50 $\mu\text{mol/L}$ GT-094 decreased expression of Sp1, Sp3 and Sp4 proteins (Fig. 4.2A) and these results were consistent with decreased expression of Sp-regulated proteins illustrated in Fig. 4.1. However, in contrast to the effects of betulinic acid and tolfenamic acid in prostate or pancreatic cancer cells, the effects of GT-094 on downregulation of Sp1, Sp3 and Sp4 proteins were not reversed by the proteasome inhibitors MG132 or lactacystin (Fig. 4.2B). MG132 alone decreased expression of Sp1, Sp3 and Sp4 in RKO and SW480 cells, whereas lactacystin alone slightly decreased Sp protein levels only in SW480 cells; however, a combination of lactacystin plus GT-094 did not reverse Sp downregulation but appeared to enhance this response. The time-dependent effects of GT-094 on Sp1, Sp3, Sp3 and Sp4 protein expression and levels of Sp-regulated genes were also determined in RKO (Fig. 4.2C) and SW480 (Fig. 4.2D) cells. In RKO cells, Sp1, Sp3 and Sp4 proteins decreased between 6-12 h after treatment and after 12 h, there was almost complete loss of these transcription factors. The time-dependent decrease in expression of bcl-2, survivin, c-MET, and VEGFR-R1 and induction of cleaved PARP followed a pattern similar to that observed for Sp proteins. However, cyclin D1 was significantly decreased within 6 h, whereas decreased VEGF expression was delayed (> 18 h), suggesting that other GT-094-mediated pathways may also be

involved. In SW480 cells, the time-dependent pattern of GT-094-induced downregulation of Sp1, Sp3, Sp4 and Sp-regulated gene products was similar with decreased expression observed within 6-12 h and highly significant downregulation after 18 h. The major exceptions were the rapidly decreased responses (within 6 h) for bcl-2, VEGF and the low molecular weight Sp3 protein.

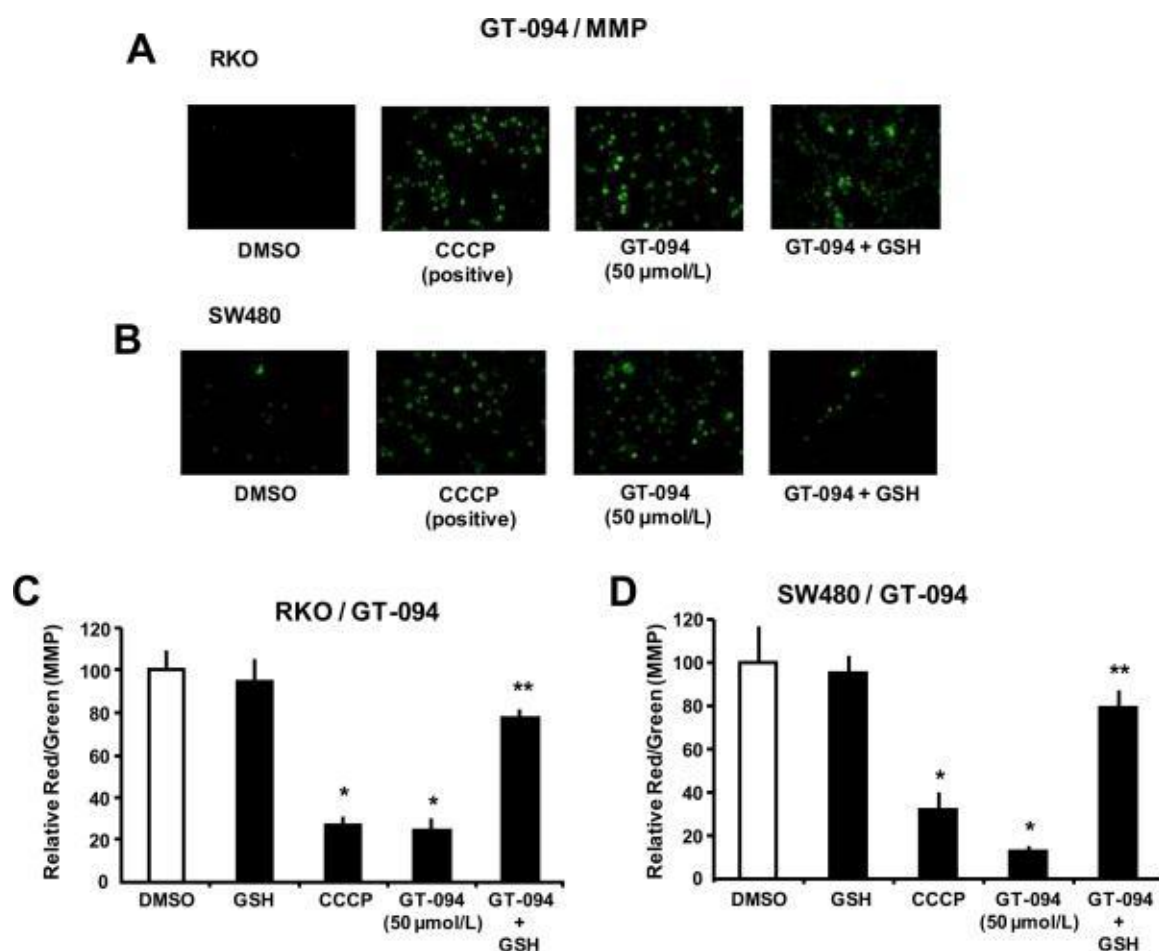

Fig. 4.3. GT-094 decreases MMP in colon cancer cells. Effects of GT-094 in RKO (A) and SW480 (B) cells. Cells were treated with 50 μmol/L GT-094, 25 μmol/L CCCP, and GT-094 plus GST for 12 h and analyzed for changes in MMP as outlined in the Materials and Methods. Quantitative changes in MMP in RKO (C) and SW480 (D) cells. Changes in MMP were determined as described in the Materials and Methods. Significant ($p < 0.05$) decreases by GT-094 or CCCP (*) and reversal of these effects by GSH (**) are indicated.

Ongoing studies with arsenic trioxide and other pro-oxidants that also decrease expression of Sp transcription factors suggest that mitochondria are the initial targets for these agents [660, 662]. Figure 4.3A illustrates the effects of 50 $\mu\text{mol/L}$ GT-094 and the mitochondriotoxic carbonyl cyanide 3-chlorophenyl hydrazone (CCCP) (24 $\mu\text{mol/L}$) which depolarizes mitochondria and decreases MMP. In RKO cells treated with the fluorescent dye JC-1 and DMSO or GSH, JC-1 formed a red fluorescent aggregate which is characteristic of high MMP. However, after treatment with GT-094 or CCCP, there was a decrease in red and an increase in green fluorescence of JC-1 which is typical of low MMP, and this was accompanied by a decreased red/green fluorescence ratio. However, cotreatment of RKO cells with GT-094 and the cellular antioxidant GSH (5 mmol/L) reversed the effects of GT-094 and restored MMP. Similar responses were observed in SW480 cells (Fig. 4.3B) and the results were quantitated in both cell lines (Figs. 4.3C and 4.3D).

Drug-induced opening of the mitochondrial pore is associated with induction of ROS, and Figure 4.4A shows that treatment of RKO cells with 50 μM GT-094 significantly induced ROS levels as determined by hydrolysis of the cell permeant probe to give a fluorescent product. In addition, cotreatment of these cells with thiol antioxidants (DTT or GSH) significantly decreased induction of ROS by GT-094. In parallel experiments in SW480 cells, we also observed that GT-094 induced ROS and this response was also attenuated after cotreatment with the thiol antioxidants (Fig. 4.4B). The role of ROS in mediating GT-094-dependent downregulation of Sp1, Sp3 and Sp4 proteins was investigated in RKO and SW480 cells. Treatment of RKO (Fig. 4.4C) and SW480 (Fig. 4.4D) cells with GT-094 decreased expression of Sp1, Sp3 and Sp4 proteins in both cell lines and this response was attenuated in cells cotreated with-

GT-094 plus the thiol antioxidants. These results demonstrate that GT-094-mediated downregulation of Sp1, Sp3 and Sp4 proteins in colon cancer cells is dependent on decreased MMP and induction of ROS, and we have observed similar effects for arsenic trioxide and curcumin in bladder and pancreatic cancer cells, respectively [661, 662].

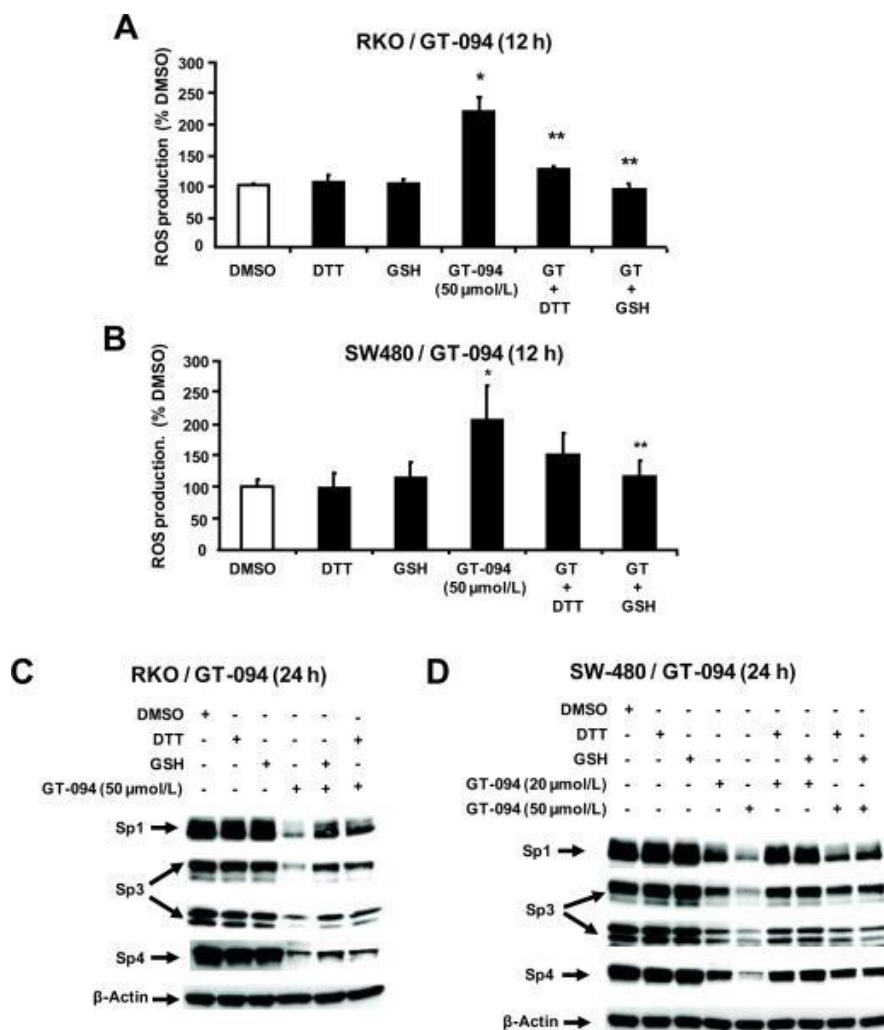

Fig. 4.4. Role of ROS in GT-094-mediated downregulation of Sp1, Sp3 and Sp4 proteins. Induction of ROS in RKO (A) and SW480 (B) cells. Cells were treated with 50 μmol/L GT-094, 1 mmol/L DTT, and 5 mmol/L GSH alone or in combination for 12 h, and ROS was determined as described in the Materials and Methods. Significant ($p < 0.05$) induction by GT-094 (*) and inhibition of this response by GSH or DTT (**) are indicated. Effects of GSH or DTT on GT-094-mediated Sp downregulation in RKO (C) and SW480 (D) cells. Cells were treated with different concentrations as indicated for 24 h, and whole cell lysates were analyzed by western blots as outlined in the Materials and Methods. Results are typical of replicate (2) experiments.

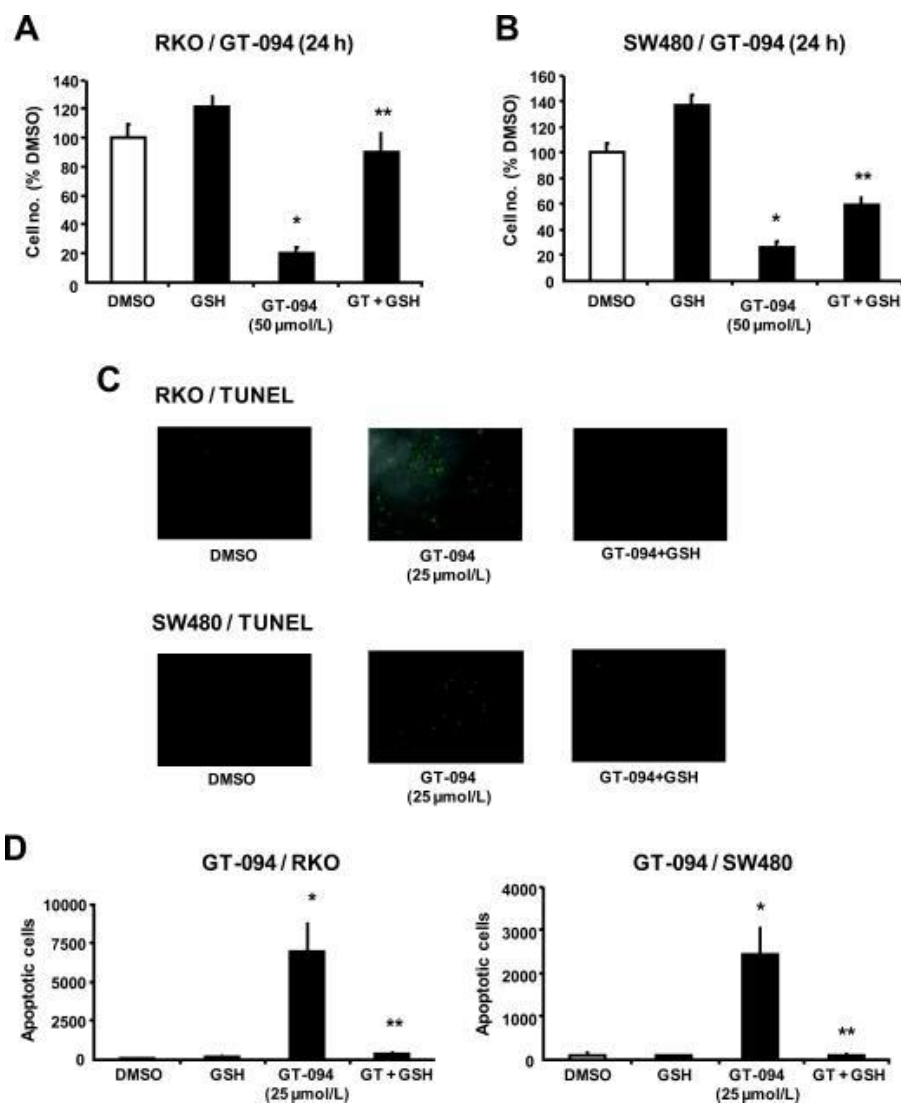

Fig. 4.5. GSH blocks GT-094-induced growth inhibition and apoptosis. Inhibition of RKO (A) and SW480 (B) cell growth by GT-094 blocked by GSH. Cells were treated with 50 μmol/L GT-094 or 5 mmol/L GSH alone or in combination for 24 h, and cell numbers were determined as described in the Materials and Methods. Significant ($p < 0.05$) inhibition by GT-094 (*) or reversal of this effect by GSH (**) are indicated. Induction of apoptosis by GT-094 ± GSH in RKO (C) and SW480 (D) cells. Cells were treated with GT-094 ± GSH for 24 h, and apoptosis was determined by TUNEL staining as described in the Materials and Methods. Significant ($p < 0.05$) induction of apoptosis by GT-094 (*) and inhibition after cotreatment with GSH (**) are indicated.

Since GT-094-induced mitochondrial disruption and induction of ROS mediates downregulation of Sp1, Sp3 and Sp4, the role of this pathway on inhibition of colon cancer cell growth and induction of apoptosis was investigated. Treatment of RKO and

SW480 cells with 50 μ M GT-094 for 24 h significantly inhibited proliferation of both cell lines; however, in cells cotreated with GT-094 and the antioxidant GSH, the growth inhibitory effects of the nitro-NSAID was attenuated (Figs. 4.5A and 4.5B). The results also show that the role of ROS-induced growth inhibition was more dominant in RKO than in SW480 cells, suggesting that other ROS-independent pathways are involved in the inhibitory effects of GT-094 in SW480 cells. Figures 4.5C and 4.5D show that GT-094 enhanced TUNEL staining, indicative of apoptosis in RKO and SW480 cells, and this effect was inhibited in cells cotreated with GT-094 plus GSH. These results confirm that GT-094-dependent activation of ROS plays an important role in the observed downregulation of Sp1, Sp3 and Sp4 transcription factors, decreased cell proliferation, and induction of apoptosis in colon cancer cells.

A recent report shows that downregulation of Sp transcription by methyl 2-cyano-3,11-dioxo-18 β -oleana-1,12-dien-30-oate (CDODA-Me) is due to disruption of miR-27a:ZBTB10 interactions in colon cancer cells, resulting in decreased expression of miR-27a and induction of ZBTB10, an Sp repressor [683]. Treatment of RKO and SW480 cells with GT-094 decreased miR-27a expression in both cell lines (Fig. 4.6A) and cotreatment with GSH reversed this effect. In parallel experiments, we observed that GT-094 induced ZBTB10 mRNA levels in RKO and SW480 cells (Fig. 4.6B) cells and this response was also attenuated after cotreatment with GSH. Downregulation of miR-27a was only observed using 50 μ M GT-094, whereas 20 and 50 μ M GT-094 induced ZBTB10 and this was particularly evident in RKO cells, suggesting that other microRNAs or other factors that play a role in regulating ZBTB10 expression may be affected by GT-094.

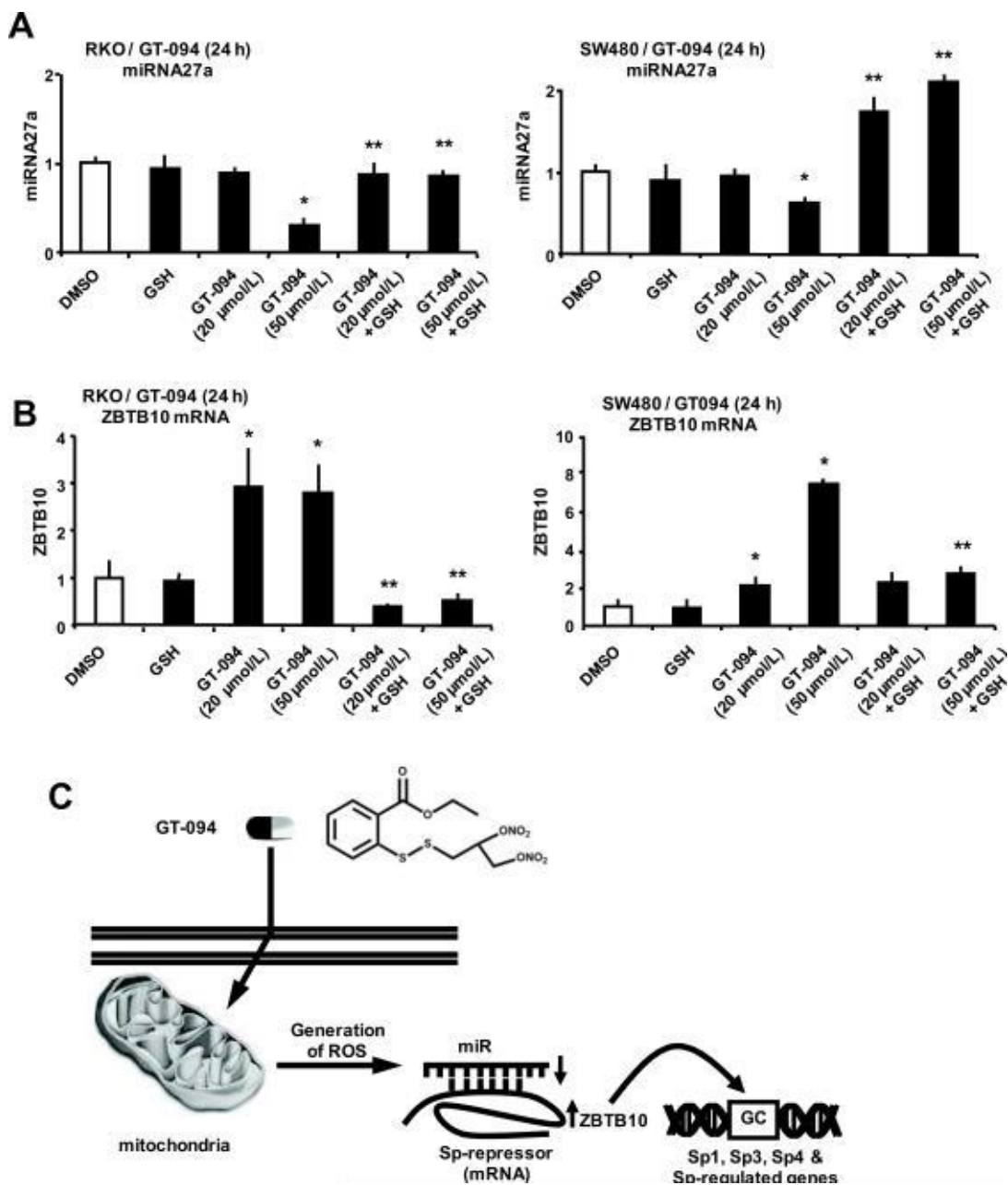

Fig. 4.6. GT-094 modulates miR-27a and ZBTB10 expression. (A) GT-094 decreases miR-27a expression in RKO and SW480 cells. Cells were treated with 20 or 50 $\mu\text{mol/L}$ GT-094 and 5 mmol/L GSH alone or in combination for 24 h, and miR-27a was determined by real time PCR as outlined in the Materials and Methods. (B) GT-094 induces ZBTB10 in RKO and SW480 cells. Cells were treated with 20 or 50 $\mu\text{mol/L}$ GT-094 and 5 mmol/L GSH alone or in combination for 24 h, and ZBTB10 mRNA levels were determined by real time PCR as outlined in the Materials and Methods. Significant ($p < 0.05$) inhibition of miR-27a and induction of ZBTB10 (*) and inhibition of these responses by GSH (**) are indicated. (C) Proposed molecular mechanism for GT-094-induced ROS and ROS-dependent disruption of the miR-27a:ZBTB10-Sp/Sp-regulated gene axis.

The time-dependent effects of GT-094 (50 μ M) on miR-27a and ZBTB4 were also investigated (Fig. 4.7). GT-094 decreased miR-27a expression in both cell lines within 6 h, whereas ZBTB10 was induced after 6-12 and 12-18 h in RKO and SW480 cells, respectively, indicating some cell context-dependent differences.

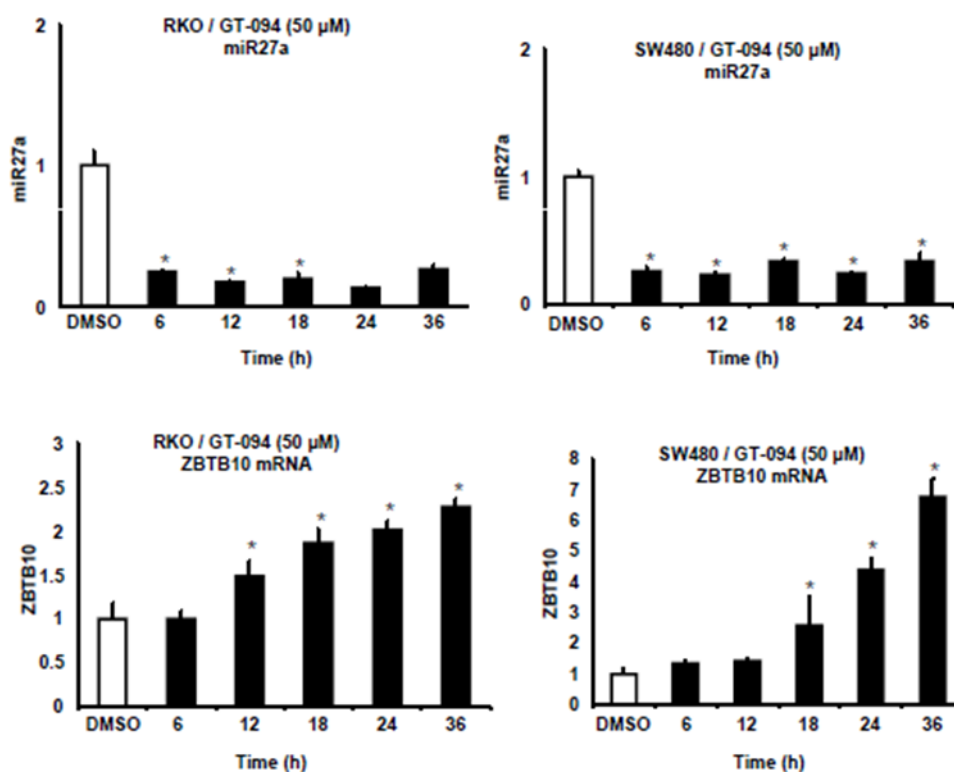

Fig. 4.7. Time course effects of GT-094 on miR-27a (A) and ZBTB10 (B). RKO and SW480 cells were treated with DMSO or GT-094 for 6, 12, 18, 24 and 36 h, and expression of miR-27a and ZBTB10 was determined by real time PCR as outlined in the Materials and Methods. Results are mean \pm SE for replicate (3) experiments, and significant ($p < 0.05$) inhibition/induction is indicated (*).

DISCUSSION

Nitro-NSAIDs are a new class of NSAIDs that have been developed to provide the prototypical anti-inflammatory and analgesic effects of NSAIDs but have minimal toxic gastrointestinal side-effects observed for aspirin and related drugs. The NO moiety enhances gastric mucosal repair and ulcer healing and ameliorates NSAID-induced toxicity. NO-NSAIDs have also been investigated for their anticancer activities and the results of *in vitro* cell culture and *in vivo* animal studies have been promising [468, 531, 538, 544, 547, 553, 560, 563, 570, 679-682]. These compounds typically inhibit cell growth and induce apoptosis in various cancer cell lines and this includes inhibition of β -catenin/Tcf complexes and downregulation of cyclin D1 in colon cancer cells [560]. Nitro-aspirin derivatives inhibit growth of tumors in mouse xenograft experiments using HT-29 colon cancer cells and this is accompanied by decreased vascularity in the tumors and downregulation of VEGF [679]. GT-094 also inhibits cancer cell and tumor growth and, in both Caco-2 and HT-29 colon cancer cells, there was no evidence for induction of apoptosis [563, 570].

Studies in this laboratory have shown that COX-2 inhibitors such as celecoxib decreased colon cancer cell growth and the NSAID tolfenamic acid decreased pancreatic cancer cell growth, and these effects were due, in part, to downregulation of Sp1, Sp3 and Sp4 transcription factors [410, 518]. GT-094 inhibited growth of RKO and SW480 colon cancer cells (Fig. 4.1A), induced PARP cleavage (Fig. 4.1B), and TUNEL staining (Fig. 4.5C) consistent with induction of apoptosis. Moreover, GT-094 also decreased expression of the antiapoptotic survivin and bcl-2 proteins and this was consistent with induction of apoptosis. GT-094 decreased expression of other proteins that play a role in cell growth (cyclin D1, c-Met and EGFR) and angiogenesis (VEGF

and VEGFR1) (Figs. 4.1C and 4.1D) and this was consistent with previous studies on NO-NSAIDs which report downregulation of cyclin D1 and VEGF [679, 680]. Previous studies in this laboratory have demonstrated by RNA interference that knockdown of Sp1, Sp3 and Sp4 individually or in combination decreases expression of the prosurvival, growth promoting, and angiogenic proteins [45, 46, 377, 632, 660-662, 670]. Results shown in Fig. 4.1 suggest that an underlying mechanism for these responses in RKO and SW480 cells may be related to downregulation of Sp1, Sp3 and Sp4 proteins and this was observed in these cells treated with GT-094 (Fig. 4.2A). The time-dependent decrease in expression of Sp1, Sp3, Sp4 and Sp-regulated genes was also determined in RKO and SW480 cells treated with GT-094 (Figs. 4.2C and 4.2D). Although the rate of decrease in expression of these proteins was similar in each of the cell lines, there were also notable exceptions, particularly for some putative Sp-regulated genes which have previously been characterized by Sp1, Sp3 and Sp4 knockdown in RNA interference studies [45, 46, 377, 632, 660-662, 670]. For example, expression of cyclin D1 (RKO cells) and bcl-2 (SW480 cells) was rapidly decreased (< 6 h) prior to Sp transcription factors or most other Sp-regulated genes, suggesting that GT-094 also induced other pathways that repress genes independent of Sp downregulation.

At least two different pathways have been linked to drug-dependent downregulation of Sp transcription factors, namely via activation of proteasomes [518, 632, 671] or through downregulation of miR-27a and the subsequent induction of the Sp repressor ZBTB10 [671, 683]. GT-094-dependent downregulation of Sp1, Sp3 and Sp4 was not reversed by proteasome inhibitors (Fig. 4.2B), whereas the NSAID tolfenamic acid and the triterpenoid betulinic acid induce proteasome-dependent degradation of Sp

transcription factors in pancreatic and prostate cancer cells, respectively [518, 671]. In contrast, CDODA-Me-dependent downregulation of Sp1, Sp3 and Sp4 in colon cancer cells was proteasome-independent as observed in this study, and the effects of CDODA-Me were due to decreased miR-27a and the subsequent induction of ZBTB10, a miR-27a-regulated mRNA [683]. Moreover, in SW480 and RKO cells transfected with antisense-miR-27a or ZBTB10 expression plasmid, there is also a decrease in Sp1, Sp3, Sp4 and Sp-regulated genes [683]. This pathway was also relevant for GT-094 which induced ZBTB10 and decreased miR-27a in colon cancer cells (Fig. 4.6 and Fig. 4.7). ZBTB10 is a member of the POK family of transcriptional repressors [685] and was first identified as an inhibitor of gastrin gene expression [686]. ZBTB10 binds to the GC-rich gastrin gene promoter and inhibits Sp1-dependent transactivation and presumably inhibits expression of Sp1, Sp3, Sp4 and Sp-regulated genes through similar interactions with their GC-rich promoters.

In ongoing studies with arsenic trioxide [662] and other pro-oxidants including curcumin and CDDO-Me in pancreatic cancer cells [660, 661], we have observed that these compounds decreased MMP and increased ROS and ROS-induced downregulation of Sp and Sp-regulated gene products. Results illustrated in Fig 4.3 and 4.4 indicate that GT-094 decreased MMP and induced ROS in RKO and SW480 cells and this was reversed in cells cotreated with the thiol antioxidant GSH. The effects of GT-094 on MMP and ROS were similar to the induction of ROS by NO-ASA in colon cancer cell lines [468]. However, induction of ROS by GT-094 in this study was also related to modulation of the miR-27a:ZBTB10-Sp1/Sp3/Sp4 axis since cotreatment with GSH attenuated GT-094-mediated downregulation of miR-27a and induction of ZBTB10 (Fig. 4.6) decreased expression of Sp1, Sp3 and Sp4 (Figs. 4.4C and 4.4D),

increased TUNEL staining (Figs. 4.5C and 4.5D), and decreased growth (Figs. 4.5A and 4.5B). It was also apparent from the cotreatment studies (GT-094 + GSH) that there were cell context-dependent differences in the inhibitory effects of GSH. For example, GSH almost totally reversed GT-094-mediated inhibition of RKO cell proliferation but only partially reversed these effects in SW480 cells (Figs. 4.5A and 4.5B), suggesting that other GT-094-induced growth inhibitory responses were important in the latter cell line. In RKO cells, 20 μ M GT-094 induced ZBTB10 mRNA but did not downregulate miR-27a (Figs. 4.6A and 4.6B), suggesting that other miRs or other factors contributed to expression of this gene and these are currently being investigated.

In summary, this study shows that like CDODA-Me, GT-094 decreases miR-27a and induces ZBTB10 expression in colon cancer cells and the subsequent downregulation of Sp1, Sp3, Sp4 and Sp-regulated proteins contributes to the anticancer activities of this compound. Moreover, GT-094 disruption of mitochondria and induction of ROS are critical elements for the subsequent ROS-dependent downstream disruption of the miR-27a:ZBTB10-Sp transcription factor axis (Fig. 4.6C). In addition, this study and a previous report in pancreatic cancer cells demonstrate that ROS suppresses miR-27a, and we have also observed similar ROS-dependent effects on the miR-27a promoter. We are currently investigating the specific *cis*-elements and *trans*-acting factors responsible for ROS-miR-27a interactions. These results demonstrate a hitherto unknown mechanism of action for GT-094 and other NO-NSAIDs in cancer cells (data not shown), and current studies are focused on the role of Sp transcription factors as targets for NO-NSAIDs and NSAIDs in cancer cells and tumors.

CHAPTER V
PHARMACOLOGIC DOSES OF ASCORBIC ACID REPRESS SPECIFICITY
PROTEIN (Sp) TRANSCRIPTION FACTORS AND Sp-REGULATED GENES IN
COLON CANCER CELLS

INTRODUCTION

Vitamin C (ascorbic acid) is an essential dietary nutrient and highly effective antioxidant that is a critical cofactor required for the activity of multiple enzymes. As a pharmacological agent, vitamin C has a controversial history, particularly with respect to the effectiveness of high doses of this compound for treating the common cold and cancer [577, 687, 688]. Cameron, Pauling and coworkers summarized a series of studies on the anticancer effects of high doses of ascorbic acid and concluded that this regimen improved the quality of life and extended the lifespan of cancer patients [584, 689]. In contrast, results of two trials carried out by Moertel and coworkers at the Mayo Clinic did not observe any benefit for patients taking vitamin C versus patients who did not receive the drug [587, 588]. Thus, the anticancer activity of vitamin C is controversial and it is possible that, in common with many other mechanism-based drugs, only select sub-sets of cancer patients may respond to ascorbic acid alone or in combination with other agents.

The use of vitamin C or any other drug for cancer chemotherapy is predicated, in part, by an understanding of the underlying mechanism of action in both *in vitro* and *in vivo* models. Several studies show that vitamin C inhibits growth of a number of cancer cell lines [580, 587, 588, 601, 690-693], and it was recently reported that EC₅₀ values using the MTT reduction assays ranged from 3 to 7 mM in 5 different human

cancer cell lines and that both intravenous and intraperitoneal administration of ascorbate in mice could result in blood levels of ascorbate as high as 20 mM [694]. Moreover, intravenous administration of ascorbate in humans can also give low mM concentrations of this compound in serum [596, 695]. It was also reported that ascorbic acid-dependent decreases in cancer cell viability was attenuated after cotreatment with catalase and the antioxidant N-acetylcysteine (NAC) and this observation was consistent with the induction of reactive oxygen species (ROS) [694]. The results also correlated with studies demonstrating the pro-oxidant activity of ascorbic acid and the identification of hydrogen peroxide in extracellular fluid of mice administered pharmacologic doses of ascorbic acid [578, 601, 605, 696].

The pro-oxidant activity induced by ascorbic acid is comparable to that observed for many other anticancer drugs such as arsenic trioxide which is currently being used for treatment of acute promyelocytic leukemia (APL) and is also being evaluated for treating solid tumors [697-699]. Ongoing studies in this laboratory confirm that arsenic trioxide decreases mitochondrial membrane potential (MMP) and induces ROS in bladder and pancreatic cancer cell lines [662]. Moreover, arsenic trioxide-induced ROS decreased expression of specificity protein (Sp) transcription factors Sp1, Sp3 and Sp4 and several Sp-regulated genes associated with cancer cell proliferation, survival and angiogenesis [662]. We therefore hypothesized that the anticancer activity of ascorbic acid may also be related to ROS-dependent downregulation of Sp transcription factors. Using colon cancer cells as a model, we have now confirmed that ascorbic acid decreases expression of Sp1, Sp3, Sp4 and Sp-dependent genes and these responses are ROS-dependent and blocked by antioxidants such as glutathione. Similar effects were observed after treating colon cancer cells with other pro-oxidants such as

hydrogen peroxide (H₂O₂). This study identifies for the first time an important ascorbic acid-induced pathway that contributes to the pro-oxidant anticancer activity of this compound.

MATERIALS AND METHODS

Cell lines, reagents and antibodies. RKO and SW480 human colon carcinoma cell lines were obtained from American Type Culture Collection (Manassas, VA). RKO and SW480 cells were maintained in Dulbecco's modified/Ham's F-12 (Sigma-Aldrich, St. Louis, MO) with phenol red supplemented with 0.22% sodium bicarbonate, 5% fetal bovine serum, and 10ml/L 100X antibiotic antimycotic solution (Sigma) containing 10,000 units penicillin, 10,000 µg streptomycin and 25 µg amphotericin B/ml, in 0.85% saline. The cells were grown in 150 cm² culture plates in an air/CO₂ (95:5) atmosphere at 37°C and passaged approximately every 3-5 days. All antibodies were purchased from Santa Cruz Biotechnology (Santa Cruz, CA), except cleaved poly (ADP) ribose polymerase (PARP) and c-Met (Cell Signaling Technology, Danvers, MA), Sp1 and VEGF-R2 (Millipore, Temecula, CA), survivin (R&D Systems, Minneapolis, MN), VEGFR1 (Abcam Inc. Cambridge, MA), and β-actin antibodies (Sigma-Aldrich). L-Ascorbic acid (99%) and glutathione, 98% (γ-glu-cys-gly, GSH) were purchased from Sigma-Aldrich. Dithiothreitol (DTT, 98%) was obtained from Boehringer Mannheim Corp, (Indianapolis, IN).

Cell proliferation assays. RKO and SW480 cancer cell lines were plated (3 x 10⁴ per well) using DMEM:Ham's F-12 medium containing 2.5% charcoal stripped fetal bovine serum (FBS) in 12-well plates and left to attach for 24 hr. Cells were then treated with either vehicle or the indicated concentrations of ascorbate (pH 7) for 3 hr and washed and further grown for additional 24 hr in growth medium in the absence of ascorbate.

Ascorbic acid was neutralized to pH 7.0 with sodium hydroxide and prepared immediately before use. After 24 hr, cells were counted using a Coulter Z1 particle counter. Each experiment was done in triplicate and results are expressed as means \pm SE for each determination.

WST-1 cell survival assay. RKO or SW480 cells were seeded in 96-well plates and then treated with H₂O₂ or *t*-butylhydroperoxide (T-BOOH) (Sigma) alone or co-treated with GSH for 24 hr. The WST-1 assay kit was obtained from Roche (Indianapolis, IN) and the assay was carried out according to the manufacturer's instructions. Cell viability was determined by the absorbance of the formazan product at 440 nm. The rate of cell survival was calculated as the percentage of the absorbance of the treated samples divided by the controls. All experiments were determined in triplicate and repeated at least two times and results are expressed as means \pm SD for each treatment group.

Apoptotic and Necrotic assays. RKO and SW480 cells (10×10^4) were seeded in two chambered glass slides and left to attach overnight. The apoptotic and necrotic assay kit was obtained from Biotium, Inc. (Hayward, CA) and contained FITC-Annexin V, ethidium homodimer III and Hoechst 3342. Cells were treated with ascorbate for 3 hr and further grown for additional 12 hr, and the apoptotic, necrotic and healthy cell detection kit was used according to the instructions provided by the manufacturer for analysis of adherent cells.

Western blot assays. RKO and SW480 cancer cells were seeded in DMEM:Ham's F-12 medium containing 2.5% charcoal-stripped FBS. After 24 hr, cells were treated with either vehicle or ascorbate for 3 hr, media was changed, and cells were incubated for 24 hr. Western blot analysis on whole cell lysates was determined using β -actin as a

loading control. Cells were cotreated with dithiothreitol (DTT) and glutathione (GSH) in the presence or absence of ascorbate, H₂O₂ or T-BOOH for the indicated times and harvested 24 hr after treatment, and whole cell lysates were obtained for analysis by western blots as previously described [632, 670, 683]. Briefly, cells were collected using high-salt buffer (50 mmol/L HEPES, 0.5 mol/L NaCl, 1.5 mmol/L MgCl₂, 1 mmol/L EGTA, 10% glycerol, and 1% Triton-X-100, pH 7.5) and 10 μL/mL of Protease Inhibitor Cocktail (Sigma Aldrich). Protein lysates were incubated for 3 min at 100°C and then separated by electrophoresis on 10% SDS-PAGE 120 V for 3 to 4 hr. Protein lysates were transferred onto polyvinylidene difluoride (PVDF) membranes by wet electroblotting in a buffer containing 25 mmol/L Tris, 192 mmol/L glycine, and 20% methanol for 1.5 hr at 180 mÅ. Membranes were blocked for 30 min with 5% TBST-Blotto [10 mmol/L Tris-HCl, 150 mmol/L NaCl (pH 8.0), 0.05% Triton X-100, and 5% nonfat dry milk] and incubated in fresh 5% TBST-Blotto with 1:500 primary antibody overnight with gentle shaking at 4°C. The PVDF membrane was washed with TBST for 10 min and then incubated with secondary antibody (1:5000) in 5% TBST-Blotto for 2 hr by gentle shaking. After washing with TBST for 10 min, the membrane was incubated with 6 mL of chemiluminescence substrate for 1 min and exposed to Kodak image station 4000 mm Pro (Carestreamhealth, Woodbridge, CT).

ROS estimation. Cellular ROS levels were evaluated with the cell permeant probe CM-H₂DCFDA (5-(and-6)-chloromethyl-2',7' dichlorodihydrofluorescein diacetate acetyl ester). CM-H₂DCFDA is nonfluorescent until removal of the acetate groups by intercellular esterases and oxidation occurs within the cell. Following treatment for 12 hr, 48-well cell culture plates containing cells were loaded with 10 μM CM-H₂DCFDA for 30 min, washed once with serum free medium, and analyzed for ROS levels using

Bio Tek Synergy 4 plate reader (Bio Tek Instruments, Inc., Winooski, VT) set at 480 nm and 525 nm excitation and emission wavelength, respectively. Cells were then washed twice with PBS and fixed with methanol for 3 min at room temperature. Methanol was then completely removed and 1 mg/ml Janus green was added to the cultures for 3 min. Following removal of Janus green, cultures were washed twice with PBS and 100 μ l of 50% methanol was added to each well. Cell counts were then determined with the plate reader set to an absorbance of 654 nm, and ROS intensities were then corrected accordingly. Three experiments were performed and analyzed on different days using 8 wells per treatment group.

Statistical analysis. All statistical tests were two-sided and statistical significance in the differences between treatment groups was determined by analysis of variance and Student's t-test. Results are expressed as means \pm SD for replicate (at least three) experiments and levels of significance are noted.

RESULTS

RKO and SW480 cells were treated with 1 - 3 mM ascorbic acid for 3 hr and after 24 hr, cells were counted to determine effects on cell survival. The results (Fig.5.1A) show that 1, 2 and 3 mM ascorbic acid significantly inhibited cell proliferation and the growth inhibitory concentrations were similar to those previously reported in other cancer cell lines [601, 694]. Growth inhibitory IC₅₀ values were 1.62 and 1.64 mM in RKO and SW480 cells, respectively. The effects of ascorbate on caspase-dependent PARP cleavage were cell context-dependent (Fig. 5.1B). In RKO cells, 2 and 3 mM ascorbate increased PARP cleavage; however, at the higher concentrations, there was a decrease in PARP cleavage and similar results were observed in SW480 cells. These results are consistent with previous studies showing that ascorbate also induces

necrosis in cancer cells and this is due, in part, to the induction of H_2O_2 which inhibits apoptosis (27, 28). The cell death pathways were further investigated using a kit containing FITC-Annexin V, ethidium homodimer III, and Hoechst 3342 that simultaneously stains apoptotic cells (green), necrotic cells (red), and healthy cells (blue). Compared to control (solvent-treated) RKO cells, ascorbate induced both apoptosis (green) and necrosis (red) and cotreatment with GSH decreased both death pathways (Fig. 5.1C). Ascorbate also induced apoptosis and necrosis in SW480 cells and these effects were also inhibited after cotreatment with GSH, demonstrating that ascorbate-induced cell death is associated with its pro-oxidant activity. Green staining (apoptosis) was more evident in SW480 cells, whereas necrosis (red staining) was more enhanced in RKO cells. Since ascorbate inhibits cell proliferation and is cytotoxic to colon cancer cells, we also investigated expression of several genes that mediate these responses. For example, treatment of RKO and SW480 cells with 2 or 3 mM ascorbate resulted in decreased expression of EGFR, c-Met and cyclin D1 proteins (Figs. 5.2A and 5. 2B). We also observed that ascorbate decreased levels of the survival genes bcl-2 and survivin in RKO and SW480 cells (Figs. 5.2C and 5.2D, respectively), and loss of these gene products is likely associated with induction of apoptosis in cancer cells as observed in the PARP cleavage and fluorescent staining assays (Figs. 5.1B and 5.1C).

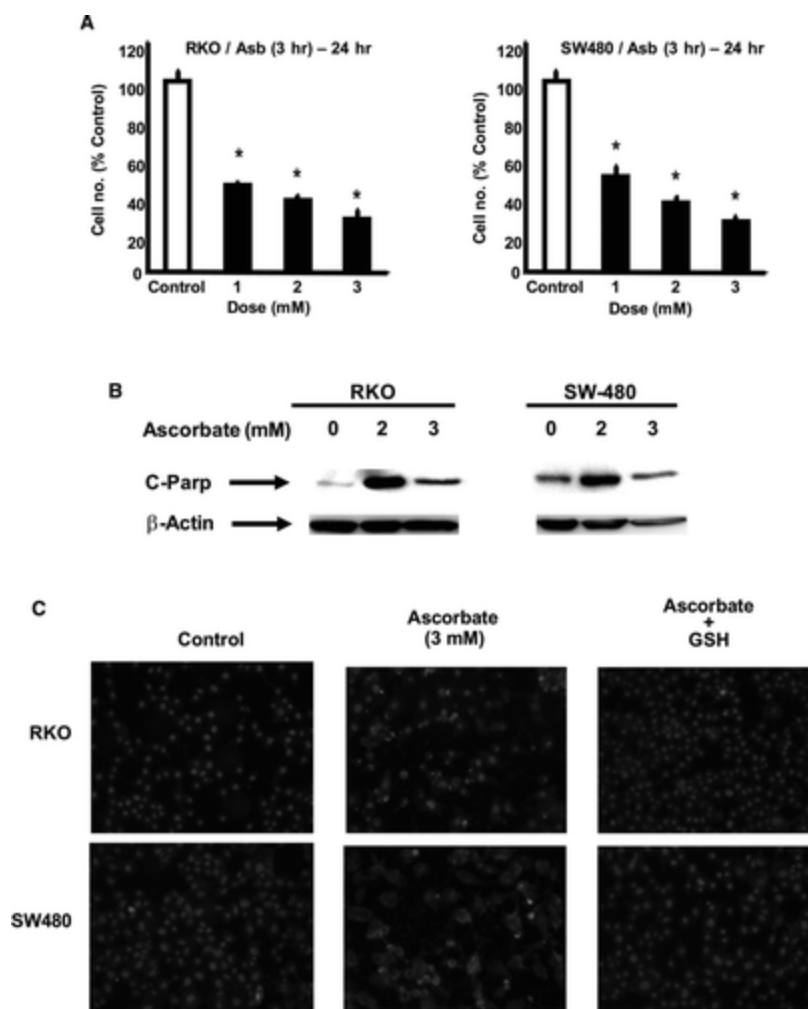

Fig. 5.1. Ascorbate is cytotoxic to colon cancer cells. A: Cell growth inhibition. RKO and SW480 cells were treated with 1–3 mM ascorbate for 3 h and, after 24 h, cell number was determined as described in the Materials and Methods. Results are expressed as means \pm SE for 3 replicate determinations, and significant ($P < 0.05$) growth inhibition is indicated (*). Induction of poly (ADP) ribose polymerase (PARP) cleavage (B) and necrosis and apoptosis (C) in RKO and SW480 cells. RKO and SW480 cells were treated with 3 mM ascorbate for 3 h and, after 24 h, cell lysates were analyzed by Western blots for PARP cleavage (B) or were stained with the fluorescent dye kit containing FITC-annexin V, ethidium homodimer III, and Hoechst 3342 and analyzed for apoptosis and necrosis as described in the Materials and Methods.

Previous RNA interference studies in this laboratory indicate that individual knockdown of Sp1, Sp3 or Sp4 and their combination decreased expression of cyclin D1, c-Met, EGFR, bcl-2 and survivin [45, 46, 377, 410, 632, 662, 670], indicating that these genes are regulated by Sp1, Sp3 and Sp4 transcription factors [45, 46, 377, 410, 632, 662, 670]. These results suggest that ascorbate may also affect expression of these proteins by downregulation of Sp transcription factors. Fig. 5.3A demonstrates that after treatment of RKO and SW480 cells with 2 and 3 mM ascorbate, levels of Sp1, Sp3 and Sp4 proteins were decreased in both cells lines. The angiogenic proteins VEGF, VEGFR1 and VEGFR2 are Sp-regulated genes [45, 46] and ascorbate also decreased expression of these proteins in RKO and SW480 cells (Fig. 5.3B) further confirming that Sp1, Sp3, Sp4 and Sp-regulated genes are critical targets of ascorbate in colon cancer cells and similar results have been observed in other cancer cell lines including KU7 (bladder), L3.6pL (pancreatic), and LNCaP and PC3 (prostate) cancer cells (data not shown). Since ascorbate treatment results in formation of hydrogen peroxide (H_2O_2) in both *in vitro* and *in vivo* models [578, 601, 605, 696], we also investigated the effects of H_2O_2 and the pro-oxidant t-butyl hydroperoxide (T-BOOH) on Sp protein expression in RKO and SW480 colon cancer cells.

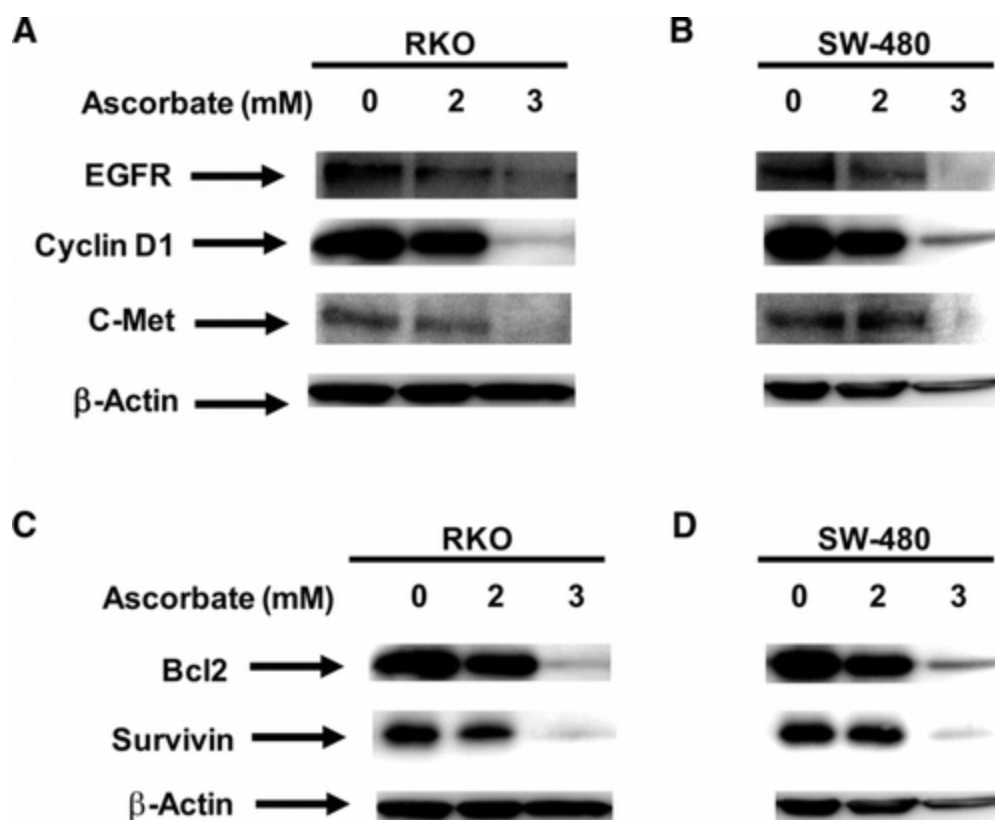

Fig. 5.2. Ascorbate-induced effects on proteins involved in cell growth and cell death. The effects of ascorbate on expression of epidermal growth factor receptor (EGFR), c-Met, and cyclin D1 proteins in RKO (A) and SW480 (B) cells and also on levels of survivin and bcl-2 and cleaved poly (ADP) ribose polymerase in RKO (C) and SW480 (D) cells were determined on whole cell lysates by Western blots as described in the Materials and Methods. Results are typical of duplicate experiments.

Both H_2O_2 and T-BOOH decreased expression of Sp1, Sp3 and Sp4 proteins and induced PARP cleavage in RKO and SW480 cells (Figs. 5.3C and 5.3D) and these results are comparable to the effects of ascorbate on expression of these proteins (Fig. 5.3A).

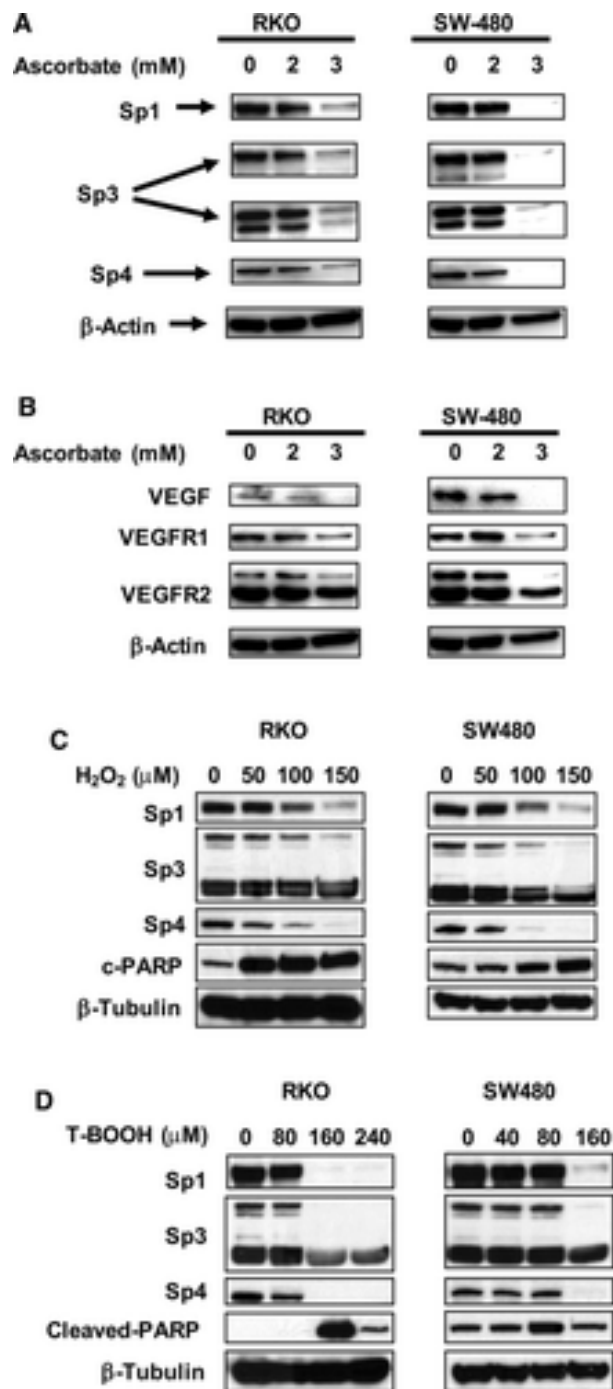

Fig. 5.3. Ascorbate, H_2O_2 , and *t*-butylhydroperoxide (T-BOOH) downregulate specificity protein (Sp)1, Sp3, and Sp4. RKO and SW480 cells were treated with ascorbate (A, B), H_2O_2 (C), and T-BOOH (D), and whole cell lysates were analyzed for Sp1, Sp3, and Sp4 proteins or vascular endothelial growth factor (VEGF), VEGFR1, and VEGFR2 proteins by Western blots as described in the Materials and Methods. Gels are typical of results obtained in multiple (2–3) experiments. Cleaved poly (ADP) ribose polymerase (PARP) was also determined in cells treated with H_2O_2 or T-BOOH.

We also investigated the induction of ROS 12 hr after incubation of RKO and SW480 cells with ascorbate for 3 hr. The results indicate that ROS was induced by ascorbate in RKO and SW480 cells at this time point and in cells cotreated with ascorbate plus the thiol antioxidants GSH and DTT, the ascorbate-induced ROS response was attenuated (Figs. 5.4A and 5.4B). Figures 4C and 4D show that GSH inhibited ascorbate-induced cell death and these results also correlated with the inhibitory effects of GSH on ascorbate-induced inhibition of RKO and SW480 cell proliferation (Figs. 5.4C and 5.4D).

Since the antioxidant GSH inhibited ascorbate-induced cytotoxicity, we also investigated the role of ROS in mediating downregulation of Sp1, Sp3 and Sp4 and Sp-regulated genes in colon cancer cells treated with 3 mM ascorbate. Figure 5.5A shows that ascorbate-induced downregulation of Sp1, Sp3 and Sp4 in RKO and SW480 cells was attenuated after cotreatment with GSH, whereas minimal effects were observed in cells cotreated with DTT. The effects of antioxidants on ascorbate-induced downregulation of growth inhibitory (Fig. 5.5B) and angiogenic/survival (Fig. 5.5C) gene products was also determined. GSH inhibited ascorbate-induced downregulation of EGFR, c-Met and cyclin D1 protein expression (Fig. 5.5C) and also VEGF, VEGFR1, VEGFR2 and survivin protein expression (Fig. 5.5B) in RKO and SW480 cells. DTT was relatively ineffective as an inhibitor in these assays and this was consistent with results summarized in Fig. 5.5A.

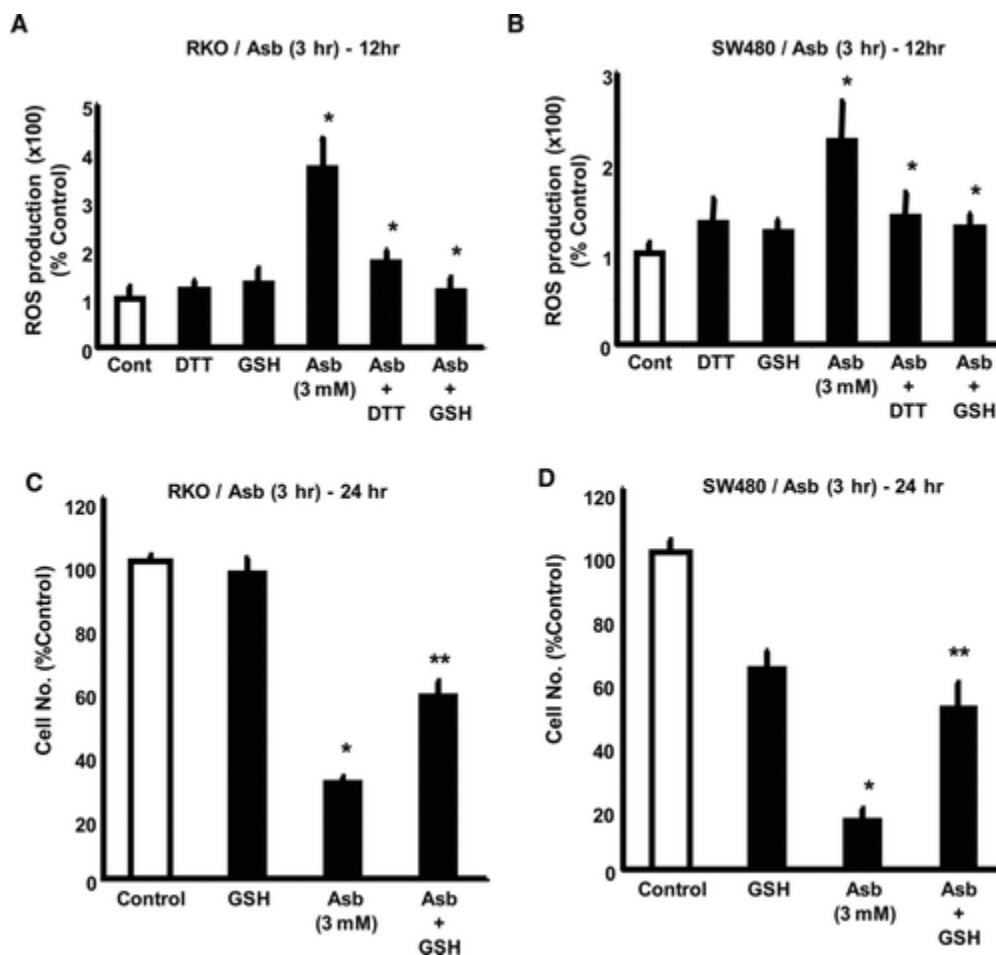

Fig. 5.4. Antioxidants inhibit ascorbate-induced ROS and growth inhibition. Induction of ROS in RKO (A) and SW480 (B) cells. Cells were treated with buffer, 3 mM ascorbate alone or in combination with antioxidants and, after 12 h, ROS was determined as described in the Materials and Methods. Cell proliferation in RKO (C) and SW480 (D) cells. Cells were treated with DMSO, ascorbate alone, or in combination with antioxidants (3 h) and, after 24 h, cell numbers were counted as described in the Materials and Methods. Results (A, B) are means \pm SE for at least 3 separate experiments per treatment group and significant ($P < 0.05$) responses induced by ascorbate (*) and inhibited after cotreatment with antioxidants (**) are indicated.

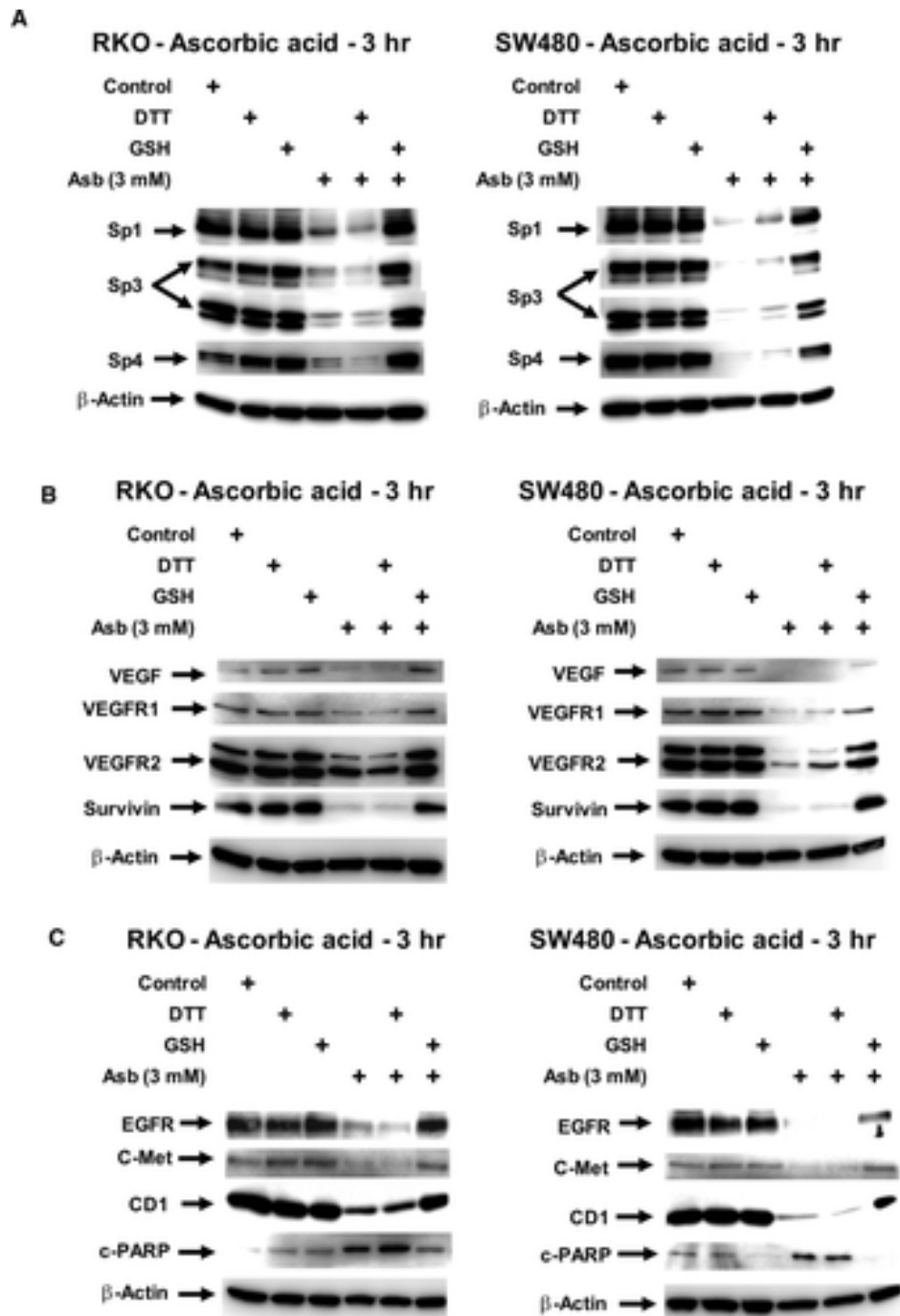

Fig. 5.5. Antioxidants inhibit ascorbate-induced repression of specificity protein (Sp)1, Sp3, Sp4, and Sp-regulated gene products. RKO and SW480 cells were treated with 3 mM ascorbate for 3 h in the presence or absence of thiol antioxidants and, after 24 h, the expression of Sp1, Sp3, and Sp4 proteins (A), Sp-regulated growth promoting (B), and angiogenic (C) proteins were determined by Western blot analysis of whole cell lysates. The blots are representative of replicated (2–3) experiments. GSH indicates glutathione; DTT, dithiothreitol.

The role of antioxidants in attenuating the effects of H_2O_2 and T-BOOH were also investigated. Figure 6A shows that H_2O_2 and T-BOOH inhibit growth of RKO cells and cotreatment with the antioxidants significantly blocks the growth inhibitory effects of the pro-oxidants. Similar results were observed in SW480 cells (Fig. 5.6A). Treatment of RKO and SW480 cells with 150 μM H_2O_2 (Fig. 5.6B) or 160 μM T-BOOH (Fig. 5.6C) decreased expression of Sp1, Sp3, Sp4 and cyclin D1 (an Sp-regulated gene); however, cotreatment with thiol antioxidants (GSH or DTT) inhibited H_2O_2 -mediated effects and GSH blocked T-BOOH-dependent downregulation of Sp1, Sp3, Sp4 and cyclin D1 (Fig. 5.6C). Thus, ascorbate and prototypical pro-oxidants such as H_2O_2 and T-BOOH inhibit growth of colon cancer cells, and this is accompanied by decreased expression of Sp1, Sp3 and Sp4 transcription factors and Sp-regulated genes that are important for to cancer cell growth (c-Met, EGFR, cyclin D1) and angiogenesis (VEGF, VEGFR1 and VEGFR2). This suggests that the anticancer activity of ascorbate is due, in part, to ROS-dependent downregulation of Sp transcription factors.

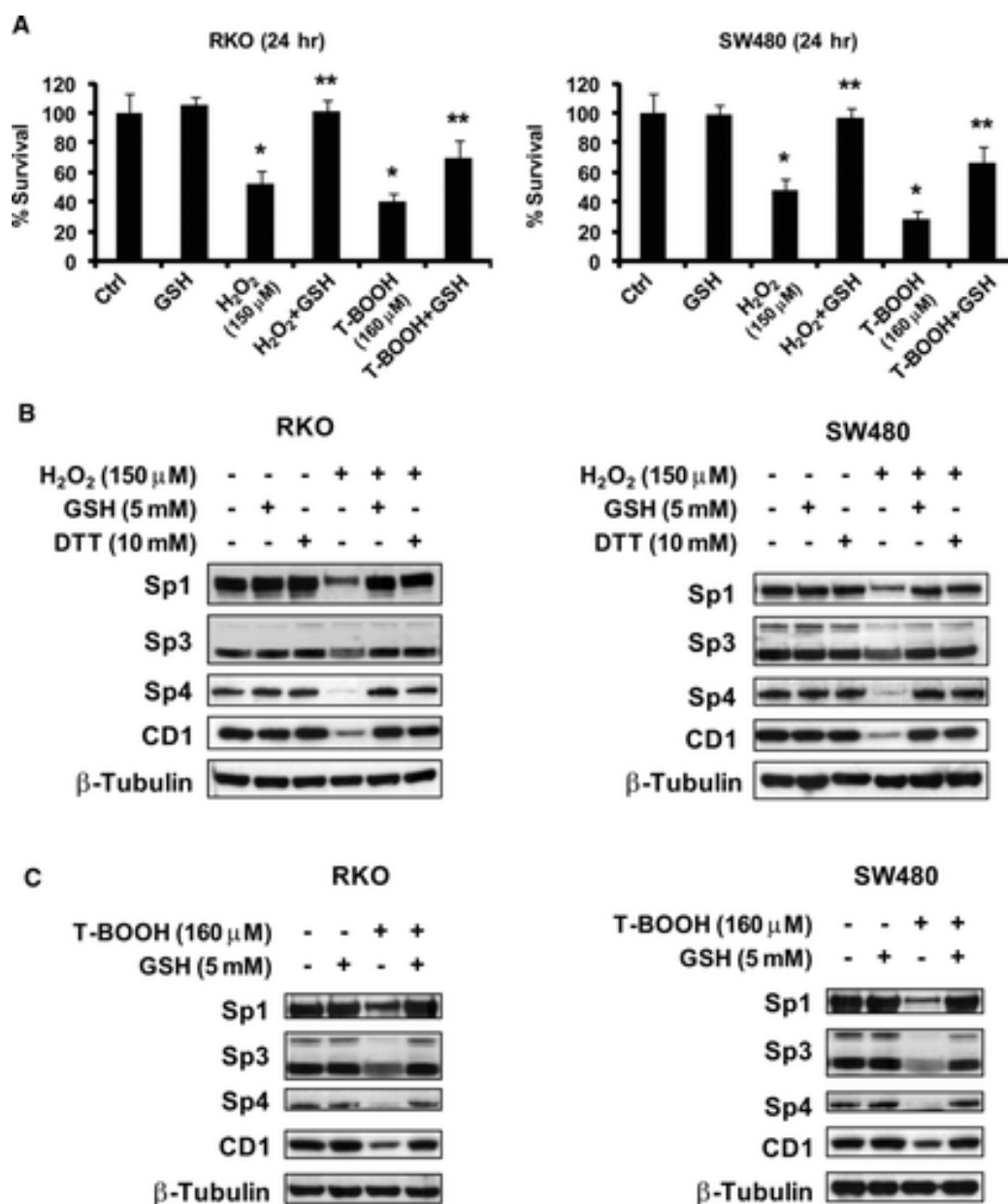

Fig. 5.6. Antioxidants block H₂O₂- and T-BOOH-induced responses in colon cancer cells. A: Cell proliferation. RKO and SW480 cells were treated with H₂O₂ (24 h) or T-BOOH (24 h) alone or in the presence of antioxidants. Cells were then counted as described in the Materials and Methods. Results are expressed as means \pm SE for at least 3 replicate experiments for each treatment group and significant ($P < 0.05$) H₂O₂- and *t*-butylhydroperoxide (T-BOOH)-induced responses (*) and inhibition by antioxidant (**) are indicated. Effects of antioxidants on H₂O₂ (B) and T-BOOH (C)-dependent downregulation of Sp transcription factors. Cells were treated as described in (A) and whole cell lysates were analyzed by Western blots. Gels are typical of replicate (at least 2) experiments. GSH indicates glutathione; DTT, dithiothreitol.

DISCUSSION

Sp/Krüppel-like factors (KLFs) are an important family of transcription factors that regulate mammalian and viral genes through high affinity interactions with GC-rich promoter elements [339, 360, 369]. Sp/KLF proteins contain three zinc fingers in their C-terminal DNA-binding domains and Sp1 was the first transcription factor identified [700]. Sp1 and other Sp transcription factors are critically important in embryonic development [339, 360, 369]; however, their expression decreases with age [366, 367, 668]. Studies in this laboratory have demonstrated high expression of Sp1, Sp3 and Sp4 proteins in cancer cell lines and in tumors (xenografts) but minimal levels were detected in non-tumor tissues in rodent models [632, 671, 683, 684] and in cells [518], and the differential expression contributes to the selectivity of agents that target Sp transcription factors. Lou and coworkers showed differences in expression of Sp1 in normal human fibroblasts (low), a non-transformed immortalized cell line (medium), and an H-Ras transformed cell line (high), and oncogene- or carcinogen-induced transformation of human fibroblasts resulted in an 8- to 18-fold increase in Sp1 protein [373]. Moreover, knockdown of Sp1 in these transformed fibroblasts markedly decreased their tumorigenicity in mouse xenografts [373]. RNA interference studies in which Sp1, Sp3 or Sp4 are knocked down individually or in combination also decreased expression of several Sp-regulated genes involved in cancer cell growth (c-Met, EGFR, cyclin D1), survival (survivin and bcl-2), and angiogenesis (VEGF, VEGFR1 and VEGFR2) [45, 46, 377, 410, 632, 662, 670]. These results clearly demonstrate the pro-oncogenic activity of Sp transcription factors and their potential importance as a drug target for cancer chemotherapy.

Ongoing studies with arsenic trioxide show that this anticancer drug induced ROS and ROS-dependent downregulation of Sp1, Sp3, Sp4 and Sp-regulated genes in several different cancer cell lines including RKO and SW480 colon cancer cells [662]. Ascorbate has also previously been identified as a pro-oxidant drug that inhibits growth of multiple cancer cell lines; however, the underlying mechanisms of action of this compound are unclear. Using RKO and SW480 colon cancer cells as models, it was apparent that ascorbate inhibited cell proliferation and induced cell death was due to both necrosis and apoptosis (Fig. 5.1), and these results are consistent with previous studies [580, 601, 690-694]. A survey of 43 cancer cell lines demonstrate variability in the IC_{50} values for growth inhibition by ascorbate (low mM to > 10 mM) [601] and our results suggest that RKO and SW480 cells are among the more sensitive cancer cell lines [601]. Induction of apoptosis was somewhat variable between the cell lines, even though ascorbate significantly decreased expression of the antiapoptotic genes bcl-2 and survivin (Fig. 5.2) in both cell lines and this may be due, in part, to the reported inhibitory effects of H_2O_2 on apoptosis [601, 605, 696]. However, the effects of ascorbate on bcl-2, survivin, cyclin D1, c-Met, EGFR, VEGF, VEGFR1 and VEGFR2 suggested that the underlying anticancer activity of this compounds may be due, in part, to targeting downregulation of Sp1, Sp3 and Sp4 transcription factors that are overexpressed in cancer cell lines and tumors [373, 518, 671, 683, 684]. Other compounds such as arsenic trioxide, curcumin and some triterpenoid anticancer agents [518, 632, 662, 671, 683] decrease expression of many of the same gene products downregulated by ascorbate (Fig. 5.2), and RNA interference studies show that expression of these genes is regulated by Sp1, Sp3 and Sp4 in cancer cells [45, 46, 377, 410, 632, 670]. Not surprisingly, we also observed that ascorbate decreased

expression of Sp1, Sp3 and Sp4 proteins in RKO and SW480 cells (Fig. 5.3), and this response correlated with the downregulation of several Sp-regulated genes (Fig. 5.2). However, it should also be noted that 1 mM ascorbate decreased colon cancer cell growth, whereas ≥ 2 mM ascorbate was required for decreased expression of Sp1, Sp3 and Sp4 proteins. Thus, ascorbate-induced Sp downregulation is not the only pathway associated with the anticancer activity of this compound.

Ascorbate-induced cytotoxicity has been associated with generation of H_2O_2 [601, 605, 662, 696-699, 701, 702], and our results with the pro-oxidants H_2O_2 and T-BOOH show that like ascorbate, these compounds are also cytotoxic and decrease proliferation and downregulate Sp1, Sp3 and Sp4 expression in RKO and SW480 cells (Figs. 5.3 and 5.6). The linkage between the pro-oxidant activities of ascorbate, H_2O_2 and T-BOOH and their effects on cell proliferation and expression of Sp transcription factors was confirmed in studies showing that these effects were partially reversed in cells after cotreatment with the antioxidant GSH which also exhibits many other activities (Figs. 5.5 and 5.6). Previous studies with hydrogen peroxide in normal cells and in cancer cell lines were mixed and have reported both increased and decreased effects on Sp1 and/or Sp-regulated genes [703-707]. However, these studies primarily attributed these effects to modulation of Sp1 phosphorylation or Sp1 DNA binding. Results in this paper clearly demonstrate that ascorbate and pro-oxidants induced downregulation of Sp1, Sp3 and Sp4 proteins and Sp-regulated gene products, and we have observed similar results for arsenic trioxide [662]. The effectiveness of DTT as an antioxidant was variable since GSH but not DTT inhibited ascorbate-induced downregulation of Sp1, Sp3 and Sp4 proteins (Fig. 5.5A), whereas both GSH and DTT blocked downregulation of Sp proteins by H_2O_2 (Fig. 5.6B). The specificity of DTT and

other antioxidants for inhibiting drug-induced Sp downregulation has previously been observed [662].

In previous studies, the triterpenoid methyl 2-cyano-3,11-dioxo-18 β -olean-1,12-dien-30-oate (CDODA-Me) decreased expression of Sp1, Sp3, Sp4 and Sp-regulated genes through induction of an Sp-repressor protein ZBTB10 in RKO and SW480 cells [683]. The effects of CDODA-Me were dependent on downregulation of microRNA-27a (miR-27a) which suppresses ZBTB10 [683, 684]. Ascorbate did not affect expression of miR-27a or ZBTB10 in RKO and SW480 cells, and other possible downstream targets are currently being investigated. In summary, results of this study show for the first time that the anticancer activity of ascorbate is due, in part, to downregulation of Sp1, Sp3 and Sp4 transcription factors and Sp-regulated genes. Many Sp-dependent genes such as EGFR, c-Met, bcl-2, VEGF and its receptors are themselves drug targets in specific cancers because of their critical role in tumor growth, survival and angiogenesis. Results of this study with ascorbate and previous reports with arsenic trioxide, curcumin, betulinic acid and CDODA-Me [518, 632, 662, 671, 683] demonstrate that many of these genes can be repressed at the same time by targeting Sp transcription factors, and we are currently developing this approach for single agent and combined therapies for cancer treatment.

CHAPTER VI

SUMMARY

Previous studies from our laboratory investigated the mechanisms of action of several synthetic and natural compounds such as tolfenamic acid, betulinic acid and curcumin as anticancer drugs that inhibit proliferation of pancreatic, prostate and bladder cancer cells in culture and tumor growth in murine xenograft or orthotopic models, respectively [518, 632, 671]. These compounds also decrease expression of Sp1, Sp3 and Sp4 proteins and several Sp-dependent genes and proteins such as VEGF, VEGFR1, survivin, cyclin D1 and bcl-2, and these responses contribute to their anticancer activity. Here we demonstrate the anticancer activity of aspirin, tolfenamic acid, GT-094 and ascorbic acid in colon cancer cells and in vivo animal models.

Aspirin is a widely used NSAID for treatment of pain, fever and inflammation and it has been extensively investigated as a chemopreventive and chemotherapeutic agent in cancer. Aspirin use is associated with decreased incidence of several cancers such as colon, breast, esophagus, lung, stomach and ovarian cancers; however, the mechanism of action of aspirin as anticancer agent is still unknown. Using colon cancer cells as a model, we investigated the mechanism of action of aspirin as chemotherapeutic agent. Aspirin inhibited the growth of RKO, SW480, HT-29 and HCT-116 colon cancer cells and also downregulated Sp1, Sp3 and Sp4 and Sp-dependent genes including the angiogenic, proliferative and survival genes, NF- κ B-p65 and β -catenin. Aspirin induces apoptosis in all cell lines and inhibited tumor growth in athymic nude mice bearing RKO cells as xenografts. This study demonstrates that aspirin activates caspases and caspase-dependent proteolysis of Sp1, Sp3 and Sp4 proteins in

colon cancer cells and tumors and, this was accompanied by downregulation of several Sp-regulated genes. Aspirin-induced Sp downregulation was due to cellular depletion of zinc and activation of nuclear caspases. Based on the similar effects of aspirin and salicylate as anticancer agents [615, 622, 623, 650] and the high serum salicylate/aspirin ratios observed in patients after treatment with aspirin [637], the cancer chemotherapeutic effects of aspirin [615-617, 619, 620] may primarily be due to the salicylate metabolite.

Tolfenamic acid has been used for pain relief as an anti-inflammatory drug [671, 672] and is currently being studied as an anticancer agent. TA induces proteasome-dependent degradation of transcription factors Sp1, Sp3, Sp4 and Sp-regulated genes in pancreatic cancer cells [518] and in this study we have investigated the effects of TA on colon cancer using both in vitro and in vivo models. TA inhibited colon cancer cell proliferation and cell viability and induced apoptosis in four different colon cancer cells, RKO, SW480, HT-29 and HCT-116. TA also decreased expression of Sp1, Sp3 and Sp4 and also several growth promoting (CD1, c-MET), angiogenic (VEGF and VEGFR) survival (survivin and bcl-2) and inflammatory (p65/p50) genes. The effects of TA in colon cancer cells and tumors was comparable to those observed for TA in other cancer cells, however, the mechanism of TA-induced effects on Sp protein expression differed from previous studies. TA-induced downregulation of nuclear Sp1, Sp3 and Sp4 and Sp dependent genes is mediated by activation of caspases and this contrasts to the proteasome dependent and independent effects of TA in other cancer cells [518-521]. Results of this study show that activation of caspases by TA is required for Sp protein degradation and current studies are focused on identifying the mechanisms of TA-

induced caspase activation and the rationale for specifically targeting Sp1, Sp3 and Sp4 proteins.

GT-094 is a prototypical NO-NSAID that acts as antiinflammatory, antiproliferative and cytoprotective agent in vitro and in vivo models [563]. In this study, we investigated the action of GT-094 in colon cancer cells and GT-094 inhibited RKO and SW480 colon cancer cell growth, induced PARP cleavage, and TUNEL staining consistent with induction of apoptosis. Moreover, GT-094 decreased expression of Sp1, Sp3 and Sp4 and Sp-dependent antiapoptotic survivin and bcl-2 proteins and this was consistent with decreased expression of other Sp-regulated gene products that play a role in cell growth (cyclin D1, c-Met, and EGFR) and angiogenesis (VEGF and VEGFR1). GT-094 also decreases mitochondrial membrane potential and induced ROS and this was accompanied by downregulation of miR-27a and upregulation of ZBTB-10, an Sp repressor. Thus like CDODA-Me [661] GT-094 inhibits miR-27a-dependent suppression of ZBTB10 in colon cancer cells and the transcriptional repressor subsequently downregulates expression of Sp1, Sp3, Sp4, and Sp-regulated proteins and this significantly contributes to the anticancer activities of this compound. Moreover, GT-094-mediated perturbation of mitochondria and induction of ROS are critical elements for the subsequent ROS-dependent disruption of the miR-27a:ZBTB10-Sp transcription factor axis. We are currently investigating the specific *cis*-elements and *trans*-acting factors responsible for ROS-dependent repression of miR-27a.

Ascorbate has previously been identified as a prooxidant drug that inhibits growth of multiple cancer cell lines; however, the underlying mechanisms of action of this compound are unclear. Using RKO and SW480 colon cancer cells as models, it was apparent that ascorbate inhibited cell proliferation and induced cell death was due

to both necrosis and apoptosis and these results are consistent with previous studies [580, 601, 690-694]. Induction of apoptosis was somewhat variable between the cell lines, even though ascorbate significantly decreased expression of the antiapoptotic genes bcl-2 and survivin in RKO and SW480 cells and this may be due, in part, to the reported inhibitory effects of H₂O₂ on apoptosis [601, 605, 696]. Not surprisingly, we also observed that ascorbate decreased expression of Sp1, Sp3, and Sp4 proteins in RKO and SW480 cells and this response was accompanied by downregulation of several Sp-regulated genes such as bcl-2, survivin, cyclin D1, c-Met, EGFR, VEGF, VEGFR1, and VEGFR2 suggesting that the underlying anticancer activity of this compounds may be due, in part, to targeting downregulation of Sp1, Sp3, and Sp4 transcription factors that are overexpressed in cancer cell lines and tumors [373, 518, 671, 683, 684]. Ascorbate-induced cytotoxicity has been associated with generation of H₂O₂ [601, 605, 662, 696-699, 701, 702], and our results with the prooxidants H₂O₂ and T-BOOH show that like ascorbate these compounds are also cytotoxic and decrease colon proliferation and downregulate Sp1, Sp3, and Sp4 expression in RKO and SW480 cells. The linkage between the prooxidant activities of ascorbate, H₂O₂, and T-BOOH and their effects on cell proliferation and expression of Sp transcription factors was confirmed in studies showing that these effects were partially reversed in cells after cotreatment with the antioxidant GSH, which also exhibits many other activities. However, Unlike CDDO-Me and GT-094 [572, 661], ascorbate did not affect expression of miR-27a or ZBTB10 in RKO and SW480 cells, and other possible downstream targets are currently being investigated.

REFERENCES

1. Ferlay J, Shin HR, Bray F, Forman D, Mathers C, Parkin DM: Estimates of worldwide burden of cancer in 2008: GLOBOCAN 2008. *Int J Cancer* 2010, 127(12):2893-2917.
2. Siegel R, Naishadham D, Jemal A: Cancer statistics, 2012. *CA Cancer J Clin* 2012, 62(1):10-29.
3. Yokota J: Tumor progression and metastasis. *Carcinogenesis* 2000, 21(3):497-503.
4. Boutwell RK: Some biological aspects of skin carcinogenesis. *Prog Exp Tumor Res* 1964, 4:207-250.
5. McCormick PJ, Bertram JS: Differential cell cycle phase specificity for neoplastic transformation and mutation to ouabain resistance induced by N-methyl-N'-nitro-N-nitrosoguanidine in synchronized C3H10T 1/2 Cl8 cells. *Proc Natl Acad Sci U S A* 1982, 79(14):4342-4346.
6. Quintanilla M, Brown K, Ramsden M, Balmain A: Carcinogen-specific mutation and amplification of Ha-ras during mouse skin carcinogenesis. *Nature* 1986, 322(6074):78-80.
7. Hollstein M, Sidransky D, Vogelstein B, Harris CC: p53 mutations in human cancers. *Science* 1991, 253(5015):49-53.
8. Weihrauch M, Bader M, Lehnert G, Wittekind C, Tannapfel A, Wrbitzky R: Carcinogen-specific mutation pattern in the p53 tumour suppressor gene in UV radiation-induced basal cell carcinoma. *Int Arch Occup Environ Health* 2002, 75(4):272-276.
9. Loeb LA: A mutator phenotype in cancer. *Cancer Res* 2001, 61(8):3230-3239.
10. Rundhaug JE, Fischer SM: Molecular mechanisms of mouse skin tumor Promotion. *Cancers (Basel)* 2010, 2(2):436-482.
11. Sarasin A: An overview of the mechanisms of mutagenesis and carcinogenesis. *Mutat Res* 2003, 544(2-3):99-106.
12. Yuspa SH, Dlugosz AA, Denning MF, Glick AB: Multistage carcinogenesis in the skin. *J Invest Dermatol Symp Proc* 1996, 1(2):147-150.
13. Trosko JE: Commentary: is the concept of "tumor promotion" a useful paradigm? *Mol Carcinog* 2001, 30(3):131-137.

14. Pitot HC: The molecular determinants of carcinogenesis. *Symp Fundam Cancer Res* 1986, 39:187-196.
15. Dixon K, Kopras E: Genetic alterations and DNA repair in human carcinogenesis. *Semin Cancer Biol* 2004, 14(6):441-448.
16. Hawighorst T, Velasco P, Streit M, Hong YK, Kyriakides TR, Brown LF, Bornstein P, Detmar M: Thrombospondin-2 plays a protective role in multistep carcinogenesis: a novel host anti-tumor defense mechanism. *EMBO J* 2001, 20(11):2631-2640.
17. Sargent L, Xu YH, Sattler GL, Meisner L, Pitot HC: Ploidy and karyotype of hepatocytes isolated from enzyme-altered foci in two different protocols of multistage hepatocarcinogenesis in the rat. *Carcinogenesis* 1989, 10(2):387-391.
18. Nowell PC: Mechanisms of tumor progression. *Cancer Res* 1986, 46(5):2203-2207.
19. Fearon ER, Vogelstein B: A genetic model for colorectal tumorigenesis. *Cell* 1990, 61(5):759-767.
20. Hanahan D, Weinberg RA: The hallmarks of cancer. *Cell* 2000, 100(1):57-70.
21. Zhou W, Goodman SN, Galizia G, Lieto E, Ferraraccio F, Pignatelli C, Purdie CA, Piris J, Morris R, Harrison DJ et al: Counting alleles to predict recurrence of early-stage colorectal cancers. *Lancet* 2002, 359(9302):219-225.
22. Leber MF, Efferth T: Molecular principles of cancer invasion and metastasis (review). *Int J Oncol* 2009, 34(4):881-895.
23. Kalluri R, Weinberg RA: The basics of epithelial-mesenchymal transition. *J Clin Invest* 2009, 119(6):1420-1428.
24. Kerbel RS, Vitoria-Petit A, Okada F, Rak J: Establishing a link between oncogenes and tumor angiogenesis. *Mol Med* 1998, 4(5):286-295.
25. Herzig M, Savarese F, Novatchkova M, Semb H, Christofori G: Tumor progression induced by the loss of E-cadherin independent of beta-catenin/Tcf-mediated Wnt signaling. *Oncogene* 2007, 26(16):2290-2298.
26. Guilford P: E-cadherin downregulation in cancer: fuel on the fire? *Mol Med Today* 1999, 5(4):172-177.
27. Gupta PB, Chaffer CL, Weinberg RA: Cancer stem cells: mirage or reality? *Nat Med* 2009, 15(9):1010-1012.

28. Hanahan D, Weinberg RA: Hallmarks of cancer: the next generation. *Cell* 2011, 144(5):646-674.
29. Oliveira PA, Colaco A, Chaves R, Guedes-Pinto H, De-La-Cruz PL, Lopes C: Chemical carcinogenesis. *An Acad Bras Cienc* 2007, 79(4):593-616.
30. Cheng N, Chytil A, Shyr Y, Joly A, Moses HL: Transforming growth factor-beta signaling-deficient fibroblasts enhance hepatocyte growth factor signaling in mammary carcinoma cells to promote scattering and invasion. *Mol Cancer Res* 2008, 6(10):1521-1533.
31. Drake JM, Graham NA, Stoyanova T, Sedghi A, Goldstein AS, Cai H, Smith DA, Zhang H, Komisopoulou E, Huang J et al: Oncogene-specific activation of tyrosine kinase networks during prostate cancer progression. *Proc Natl Acad Sci U S A* 2012, 109(5):1643-1648.
32. Davies MA, Samuels Y: Analysis of the genome to personalize therapy for melanoma. *Oncogene* 2010, 29(41):5545-5555.
33. Jiang BH, Liu LZ: PI3K/PTEN signaling in angiogenesis and tumorigenesis. *Adv Cancer Res* 2009, 102:19-65.
34. Burkhart DL, Sage J: Cellular mechanisms of tumour suppression by the retinoblastoma gene. *Nat Rev Cancer* 2008, 8(9):671-682.
35. Lipinski MM, Jacks T: The retinoblastoma gene family in differentiation and development. *Oncogene* 1999, 18(55):7873-7882.
36. Ghebranious N, Donehower LA: Mouse models in tumor suppression. *Oncogene* 1998, 17(25):3385-3400.
37. Junttila MR, Evan GI: p53--a Jack of all trades but master of none. *Nat Rev Cancer* 2009, 9(11):821-829.
38. Elmore S: Apoptosis: a review of programmed cell death. *Toxicol Pathol* 2007, 35(4):495-516.
39. Blasco MA: Telomeres and human disease: ageing, cancer and beyond. *Nat Rev Genet* 2005, 6(8):611-622.
40. Artandi SE, DePinho RA: Telomeres and telomerase in cancer. *Carcinogenesis* 2010, 31(1):9-18.
41. Raynaud CM, Hernandez J, Llorca FP, Nuciforo P, Mathieu MC, Commo F, Delaloge S, Sabatier L, Andre F, Soria JC: DNA damage repair and telomere length in normal breast, preneoplastic lesions, and invasive cancer. *Am J Clin Oncol* 2010, 33(4):341-345.

42. Hanahan D, Folkman J: Patterns and emerging mechanisms of the angiogenic switch during tumorigenesis. *Cell* 1996, 86(3):353-364.
43. Shinkaruk S, Bayle M, Lain G, Deleris G: Vascular endothelial cell growth factor (VEGF), an emerging target for cancer chemotherapy. *Curr Med Chem Anticancer Agents* 2003, 3(2):95-117.
44. Folkman J: Role of angiogenesis in tumor growth and metastasis. *Semin Oncol* 2002, 29(6 Suppl 16):15-18.
45. Abdelrahim M, Smith R, 3rd, Burghardt R, Safe S: Role of Sp proteins in regulation of vascular endothelial growth factor expression and proliferation of pancreatic cancer cells. *Cancer Res* 2004, 64(18):6740-6749.
46. Higgins KJ, Abdelrahim M, Liu S, Yoon K, Safe S: Regulation of vascular endothelial growth factor receptor-2 expression in pancreatic cancer cells by Sp proteins. *Biochem Biophys Res Commun* 2006, 345(1):292-301.
47. Klymkowsky MW, Savagner P: Epithelial-mesenchymal transition: a cancer researcher's conceptual friend and foe. *Am J Pathol* 2009, 174(5):1588-1593.
48. Johnsen M, Lund LR, Romer J, Almholt K, Dano K: Cancer invasion and tissue remodeling: common themes in proteolytic matrix degradation. *Curr Opin Cell Biol* 1998, 10(5):667-671.
49. Rosivatz E, Becker I, Specht K, Fricke E, Luber B, Busch R, Hofler H, Becker KF: Differential expression of the epithelial-mesenchymal transition regulators snail, SIP1, and twist in gastric cancer. *Am J Pathol* 2002, 161(5):1881-1891.
50. Tenesa A, Dunlop MG: New insights into the aetiology of colorectal cancer from genome-wide association studies. *Nat Rev Genet* 2009, 10(6):353-358.
51. Jemal A, Siegel R, Ward E, Hao Y, Xu J, Thun MJ: Cancer statistics, 2009. *CA Cancer J Clin* 2009, 59(4):225-249.
52. Hawk ET, Levin B: Colorectal cancer prevention. *J Clin Oncol* 2005, 23(2):378-391.
53. Huxley RR, Ansary-Moghaddam A, Clifton P, Czernichow S, Parr CL, Woodward M: The impact of dietary and lifestyle risk factors on risk of colorectal cancer: a quantitative overview of the epidemiological evidence. *Int J Cancer* 2009, 125(1):171-180.
54. Eaden JA, Abrams KR, Mayberry JF: The risk of colorectal cancer in ulcerative colitis: a meta-analysis. *Gut* 2001, 48(4):526-535.
55. Itzkowitz SH, Harpaz N: Diagnosis and management of dysplasia in patients with inflammatory bowel diseases. *Gastroenterology* 2004, 126(6):1634-1648.

56. Triantafyllidis JK, Nasioulas G, Kosmidis PA: Colorectal cancer and inflammatory bowel disease: epidemiology, risk factors, mechanisms of carcinogenesis and prevention strategies. *Anticancer Res* 2009, 29(7):2727-2737.
57. Jass JR: Colorectal cancer: a multipathway disease. *Crit Rev Oncog* 2006, 12(3-4):273-287.
58. Fearon ER: Molecular genetics of colorectal cancer. *Annu Rev Pathol* 2011, 6:479-507.
59. Bodmer W: The somatic evolution of cancer. The Harveian Oration of 1996. *J R Coll Physicians Lond* 1997, 31(1):82-89.
60. Goel GA, Kandiel A, Achkar JP, Lashner B: Molecular pathways underlying IBD-associated colorectal neoplasia: therapeutic implications. *Am J Gastroenterol* 2011, 106(4):719-730.
61. Lakatos PL, Lakatos L: Risk for colorectal cancer in ulcerative colitis: changes, causes and management strategies. *World J Gastroenterol* 2008, 14(25):3937-3947.
62. Jass JR: Classification of colorectal cancer based on correlation of clinical, morphological and molecular features. *Histopathology* 2007, 50(1):113-130.
63. Winawer SJ, Zauber AG, Ho MN, O'Brien MJ, Gottlieb LS, Sternberg SS, Waye JD, Schapiro M, Bond JH, Panish JF et al: Prevention of colorectal cancer by colonoscopic polypectomy. The National Polyp Study Workgroup. *N Engl J Med* 1993, 329(27):1977-1981.
64. Rex DK, Lehman GA, Ulbright TM, Smith JJ, Pound DC, Hawes RH, Helper DJ, Wiersema MJ, Langefeld CD, Li W: Colonic neoplasia in asymptomatic persons with negative fecal occult blood tests: influence of age, gender, and family history. *Am J Gastroenterol* 1993, 88(6):825-831.
65. Rustgi AK: The genetics of hereditary colon cancer. *Genes Dev* 2007, 21(20):2525-2538.
66. Terzic J, Grivennikov S, Karin E, Karin M: Inflammation and colon cancer. *Gastroenterology* 2010, 138(6):2101-2114 e2105.
67. Lynch HT, de la Chapelle A: Hereditary colorectal cancer. *N Engl J Med* 2003, 348(10):919-932.
68. Galiatsatos P, Foulkes WD: Familial adenomatous polyposis. *Am J Gastroenterol* 2006, 101(2):385-398.
69. Segditsas S, Tomlinson I: Colorectal cancer and genetic alterations in the Wnt pathway. *Oncogene* 2006, 25(57):7531-7537.

70. Polakis P: The many ways of Wnt in cancer. *Curr Opin Genet Dev* 2007, 17(1):45-51.
71. Kinzler KW, Vogelstein B: Lessons from hereditary colorectal cancer. *Cell* 1996, 87(2):159-170.
72. Aoki K, Taketo MM: Adenomatous polyposis coli (APC): a multi-functional tumor suppressor gene. *J Cell Sci* 2007, 120(Pt 19):3327-3335.
73. Moon RT, Kohn AD, De Ferrari GV, Kaykas A: WNT and beta-catenin signalling: diseases and therapies. *Nat Rev Genet* 2004, 5(9):691-701.
74. Huang M, Wang Y, Sun D, Zhu H, Yin Y, Zhang W, Yang S, Quan L, Bai J, Wang S et al: Identification of genes regulated by Wnt/beta-catenin pathway and involved in apoptosis via microarray analysis. *BMC Cancer* 2006, 6:221.
75. Mosimann C, Hausmann G, Basler K: Beta-catenin hits chromatin: regulation of Wnt target gene activation. *Nat Rev Mol Cell Biol* 2009, 10(4):276-286.
76. Batlle E, Henderson JT, Beghtel H, van den Born MM, Sancho E, Huls G, Meeldijk J, Robertson J, van de Wetering M, Pawson T et al: Beta-catenin and TCF mediate cell positioning in the intestinal epithelium by controlling the expression of EphB/ephrinB. *Cell* 2002, 111(2):251-263.
77. van de Wetering M, Sancho E, Verweij C, de Lau W, Oving I, Hurlstone A, van der Horn K, Batlle E, Coudreuse D, Haramis AP et al: The beta-catenin/TCF-4 complex imposes a crypt progenitor phenotype on colorectal cancer cells. *Cell* 2002, 111(2):241-250.
78. Warthin AS: Heredity with reference to carcinoma - As shown by the study of the cases examined in the Pathological Laboratory of the University of Michigan, 1895-1913. *Arch Intern Med* 1913, 12(5):546-555.
79. Lynch HT, Krush AJ: Cancer family "G" revisited: 1895-1970. *Cancer* 1971, 27(6):1505-1511.
80. Lynch HT, Shaw MW, Magnuson CW, Larsen AL, Krush AJ: Hereditary factors in cancer. Study of two large midwestern kindreds. *Arch Intern Med* 1966, 117(2):206-212.
81. Lynch HT, Lynch JF: What the physician needs to know about Lynch syndrome: an update. *Oncology (Williston Park)* 2005, 19(4):455-463; discussion 463-454, 466, 469.
82. Peltomaki P: Role of DNA mismatch repair defects in the pathogenesis of human cancer. *J Clin Oncol* 2003, 21(6):1174-1179.

83. Valentini AM, Armentano R, Pirrelli M, Caruso ML: Chemotherapeutic agents for colorectal cancer with a defective mismatch repair system: the state of the art. *Cancer Treat Rev* 2006, 32(8):607-618.
84. Pors K, Patterson LH: DNA mismatch repair deficiency, resistance to cancer chemotherapy and the development of hypersensitive agents. *Curr Top Med Chem* 2005, 5(12):1133-1149.
85. Xu Y, Pasche B: TGF-beta signaling alterations and susceptibility to colorectal cancer. *Hum Mol Genet* 2007, 16 Spec No 1:R14-20.
86. Massague J, Blain SW, Lo RS: TGFbeta signaling in growth control, cancer, and heritable disorders. *Cell* 2000, 103(2):295-309.
87. Biswas S, Chytil A, Washington K, Romero-Gallo J, Gorska AE, Wirth PS, Gautam S, Moses HL, Grady WM: Transforming growth factor beta receptor type II inactivation promotes the establishment and progression of colon cancer. *Cancer Res* 2004, 64(14):4687-4692.
88. Miele L: Notch signaling. *Clin Cancer Res* 2006, 12(4):1074-1079.
89. Rubin LL, de Sauvage FJ: Targeting the Hedgehog pathway in cancer. *Nat Rev Drug Discov* 2006, 5(12):1026-1033.
90. Kalderon D: Transducing the hedgehog signal. *Cell* 2000, 103(3):371-374.
91. Qualtrough D, Buda A, Gaffield W, Williams AC, Paraskeva C: Hedgehog signalling in colorectal tumour cells: induction of apoptosis with cyclopamine treatment. *Int J Cancer* 2004, 110(6):831-837.
92. Douard R, Moutereau S, Pernet P, Chimingqi M, Allory Y, Manivet P, Conti M, Vaubourdolle M, Cugnenc PH, Loric S: Sonic Hedgehog-dependent proliferation in a series of patients with colorectal cancer. *Surgery* 2006, 139(5):665-670.
93. Oniscu A, James RM, Morris RG, Bader S, Malcomson RD, Harrison DJ: Expression of Sonic hedgehog pathway genes is altered in colonic neoplasia. *J Pathol* 2004, 203(4):909-917.
94. Monzo M, Moreno I, Artells R, Ibeas R, Navarro A, Moreno J, Hernandez R, Granell M, Pie J: Sonic hedgehog mRNA expression by real-time quantitative PCR in normal and tumor tissues from colorectal cancer patients. *Cancer Lett* 2006, 233(1):117-123.
95. Barbacid M: ras genes. *Annu Rev Biochem* 1987, 56:779-827.
96. Konstantinopoulos PA, Karamouzis MV, Papavassiliou AG: Post-translational modifications and regulation of the RAS superfamily of GTPases as anticancer targets. *Nat Rev Drug Discov* 2007, 6(7):541-555.

97. Bos JL: ras oncogenes in human cancer: a review. *Cancer Res* 1989, 49(17):4682-4689.
98. Lievre A, Bachet JB, Boige V, Cayre A, Le Corre D, Buc E, Ychou M, Bouche O, Landi B, Louvet C et al: KRAS mutations as an independent prognostic factor in patients with advanced colorectal cancer treated with cetuximab. *J Clin Oncol* 2008, 26(3):374-379.
99. Arteaga CL: The epidermal growth factor receptor: from mutant oncogene in nonhuman cancers to therapeutic target in human neoplasia. *J Clin Oncol* 2001, 19(18 Suppl):32S-40S.
100. Lee JJ, Chu E: First-line use of anti-epidermal growth factor receptor monoclonal antibodies in metastatic colorectal cancer. *Clin Colorectal Cancer* 2007, 6 Suppl 2:S42-46.
101. Vokes EE, Chu E: Anti-EGFR therapies: clinical experience in colorectal, lung, and head and neck cancers. *Oncology (Williston Park)* 2006, 20(5 Suppl 2):15-25.
102. Kim ES, Khuri FR, Herbst RS: Epidermal growth factor receptor biology (IMC-C225). *Curr Opin Oncol* 2001, 13(6):506-513.
103. Katso R, Okkenhaug K, Ahmadi K, White S, Timms J, Waterfield MD: Cellular function of phosphoinositide 3-kinases: implications for development, homeostasis, and cancer. *Annu Rev Cell Dev Biol* 2001, 17:615-675.
104. Vivanco I, Sawyers CL: The phosphatidylinositol 3-Kinase AKT pathway in human cancer. *Nat Rev Cancer* 2002, 2(7):489-501.
105. Fresno Vara JA, Casado E, de Castro J, Cejas P, Belda-Iniesta C, Gonzalez-Baron M: PI3K/Akt signalling pathway and cancer. *Cancer Treat Rev* 2004, 30(2):193-204.
106. LoPiccolo J, Granville CA, Gills JJ, Dennis PA: Targeting Akt in cancer therapy. *Anticancer Drugs* 2007, 18(8):861-874.
107. Sharma S, Kelly TK, Jones PA: Epigenetics in cancer. *Carcinogenesis* 2010, 31(1):27-36.
108. Suzuki MM, Bird A: DNA methylation landscapes: provocative insights from epigenomics. *Nat Rev Genet* 2008, 9(6):465-476.
109. Feinberg AP, Tycko B: The history of cancer epigenetics. *Nat Rev Cancer* 2004, 4(2):143-153.

110. van Engeland M, Derks S, Smits KM, Meijer GA, Herman JG: Colorectal cancer epigenetics: complex simplicity. *J Clin Oncol* 2011, 29(10):1382-1391.
111. Miranda TB, Jones PA: DNA methylation: the nuts and bolts of repression. *J Cell Physiol* 2007, 213(2):384-390.
112. Herman JG, Baylin SB: Gene silencing in cancer in association with promoter hypermethylation. *N Engl J Med* 2003, 349(21):2042-2054.
113. Feinberg AP, Gehrke CW, Kuo KC, Ehrlich M: Reduced genomic 5-methylcytosine content in human colonic neoplasia. *Cancer Res* 1988, 48(5):1159-1161.
114. Goetz SE, Vogelstein B, Hamilton SR, Feinberg AP: Hypomethylation of DNA from benign and malignant human colon neoplasms. *Science* 1985, 228(4696):187-190.
115. Kim MS, Lee J, Sidransky D: DNA methylation markers in colorectal cancer. *Cancer Metastasis Rev* 2010, 29(1):181-206.
116. Baylin SB, Herman JG, Graff JR, Vertino PM, Issa JP: Alterations in DNA methylation: a fundamental aspect of neoplasia. *Adv Cancer Res* 1998, 72:141-196.
117. Suzuki K, Suzuki I, Leodolter A, Alonso S, Horiuchi S, Yamashita K, Perucho M: Global DNA demethylation in gastrointestinal cancer is age dependent and precedes genomic damage. *Cancer Cell* 2006, 9(3):199-207.
118. Wajed SA, Laird PW, DeMeester TR: DNA methylation: an alternative pathway to cancer. *Ann Surg* 2001, 234(1):10-20.
119. Ahuja N, Li Q, Mohan AL, Baylin SB, Issa JP: Aging and DNA methylation in colorectal mucosa and cancer. *Cancer Res* 1998, 58(23):5489-5494.
120. Lopes EC, Valls E, Figueroa ME, Mazur A, Meng FG, Chiosis G, Laird PW, Schreiber-Agus N, Grealley JM, Prokhortchouk E et al: Kaiso contributes to DNA methylation-dependent silencing of tumor suppressor genes in colon cancer cell lines. *Cancer Res* 2008, 68(18):7258-7263.
121. Prokhortchouk A, Sansom O, Selfridge J, Caballero IM, Salozhin S, Aithozhina D, Cerchietti L, Meng FG, Augenlicht LH, Mariadason JM et al: Kaiso-deficient mice show resistance to intestinal cancer. *Mol Cell Biol* 2006, 26(1):199-208.
122. Mohammad HP, Cai Y, McGarvey KM, Easwaran H, Van Neste L, Ohm JE, O'Hagan HM, Baylin SB: Polycomb CBX7 promotes initiation of heritable repression of genes frequently silenced with cancer-specific DNA hypermethylation. *Cancer Res* 2009, 69(15):6322-6330.

123. Vire E, Brenner C, Deplus R, Blanchon L, Fraga M, Didelot C, Morey L, Van Eynde A, Bernard D, Vanderwinden JM et al: The Polycomb group protein EZH2 directly controls DNA methylation. *Nature* 2006, 439(7078):871-874.
124. Lu J, Getz G, Miska EA, Alvarez-Saavedra E, Lamb J, Peck D, Sweet-Cordero A, Ebert BL, Mak RH, Ferrando AA et al: MicroRNA expression profiles classify human cancers. *Nature* 2005, 435(7043):834-838.
125. Lanza G, Ferracin M, Gafa R, Veronese A, Spizzo R, Piciorri F, Liu CG, Calin GA, Croce CM, Negrini M: mRNA/microRNA gene expression profile in microsatellite unstable colorectal cancer. *Mol Cancer* 2007, 6:54.
126. Suzuki HI, Yamagata K, Sugimoto K, Iwamoto T, Kato S, Miyazono K: Modulation of microRNA processing by p53. *Nature* 2009, 460(7254):529-533.
127. Slaby O, Svoboda M, Michalek J, Vyzula R: MicroRNAs in colorectal cancer: translation of molecular biology into clinical application. *Mol Cancer* 2009, 8:102.
128. Burk U, Schubert J, Wellner U, Schmalhofer O, Vincan E, Spaderna S, Brabletz T: A reciprocal repression between ZEB1 and members of the miR-200 family promotes EMT and invasion in cancer cells. *EMBO Rep* 2008, 9(6):582-589.
129. Huang Q, Gumireddy K, Schrier M, le Sage C, Nagel R, Nair S, Egan DA, Li A, Huang G, Klein-Szanto AJ et al: The microRNAs miR-373 and miR-520c promote tumour invasion and metastasis. *Nat Cell Biol* 2008, 10(2):202-210.
130. Shi B, Sepp-Lorenzino L, Prisco M, Linsley P, deAngelis T, Baserga R: Micro RNA 145 targets the insulin receptor substrate-1 and inhibits the growth of colon cancer cells. *J Biol Chem* 2007, 282(45):32582-32590.
131. Lujambio A, Calin GA, Villanueva A, Ropero S, Sanchez-Cespedes M, Blanco D, Montuenga LM, Rossi S, Nicoloso MS, Faller WJ et al: A microRNA DNA methylation signature for human cancer metastasis. *Proc Natl Acad Sci U S A* 2008, 105(36):13556-13561.
132. Toyota M, Suzuki H, Sasaki Y, Maruyama R, Imai K, Shinomura Y, Tokino T: Epigenetic silencing of microRNA-34b/c and B-cell translocation gene 4 is associated with CpG island methylation in colorectal cancer. *Cancer Res* 2008, 68(11):4123-4132.
133. Lujambio A, Ropero S, Ballestar E, Fraga MF, Cerrato C, Setien F, Casado S, Suarez-Gauthier A, Sanchez-Cespedes M, Git A et al: Genetic unmasking of an epigenetically silenced microRNA in human cancer cells. *Cancer Res* 2007, 67(4):1424-1429.
134. Feagins LA, Souza RF, Spechler SJ: Carcinogenesis in IBD: potential targets for the prevention of colorectal cancer. *Nat Rev Gastroenterol Hepatol* 2009, 6(5):297-305.

135. Sheng H, Shao J, Williams CS, Pereira MA, Taketo MM, Oshima M, Reynolds AB, Washington MK, DuBois RN, Beauchamp RD: Nuclear translocation of beta-catenin in hereditary and carcinogen-induced intestinal adenomas. *Carcinogenesis* 1998, 19(4):543-549.
136. Waldner MJ, Neurath MF: Cytokines in colitis associated cancer: potential drug targets? *Inflamm Allergy Drug Targets* 2008, 7(3):187-194.
137. Atreya I, Atreya R, Neurath MF: NF-kappaB in inflammatory bowel disease. *J Intern Med* 2008, 263(6):591-596.
138. Atreya I, Neurath MF: Immune cells in colorectal cancer: prognostic relevance and therapeutic strategies. *Expert Rev Anticancer Ther* 2008, 8(4):561-572.
139. Clevers H: At the crossroads of inflammation and cancer. *Cell* 2004, 118(6):671-674.
140. Askling J, Dickman PW, Karlen P, Brostrom O, Lapidus A, Lofberg R, Ekblom A: Family history as a risk factor for colorectal cancer in inflammatory bowel disease. *Gastroenterology* 2001, 120(6):1356-1362.
141. Yu H, Pardoll D, Jove R: STATs in cancer inflammation and immunity: a leading role for STAT3. *Nat Rev Cancer* 2009, 9(11):798-809.
142. Sakamoto K, Maeda S, Hikiba Y, Nakagawa H, Hayakawa Y, Shibata W, Yanai A, Ogura K, Omata M: Constitutive NF-kappaB activation in colorectal carcinoma plays a key role in angiogenesis, promoting tumor growth. *Clin Cancer Res* 2009, 15(7):2248-2258.
143. Westbrook AM, Wei B, Braun J, Schiestl RH: Intestinal mucosal inflammation leads to systemic genotoxicity in mice. *Cancer Res* 2009, 69(11):4827-4834.
144. Meira LB, Bugni JM, Green SL, Lee CW, Pang B, Borenshtein D, Rickman BH, Rogers AB, Moroski-Erkul CA, McFaline JL et al: DNA damage induced by chronic inflammation contributes to colon carcinogenesis in mice. *J Clin Invest* 2008, 118(7):2516-2525.
145. Hussain SP, Hofseth LJ, Harris CC: Radical causes of cancer. *Nat Rev Cancer* 2003, 3(4):276-285.
146. Kraus S, Arber N: Inflammation and colorectal cancer. *Curr Opin Pharmacol* 2009, 9(4):405-410.
147. Choi J, Yoon SH, Kim JE, Rhee KH, Youn HS, Chung MH: Gene-specific oxidative DNA damage in *Helicobacter pylori*-infected human gastric mucosa. *Int J Cancer* 2002, 99(4):485-490.

148. Neufert C, Becker C, Neurath MF: An inducible mouse model of colon carcinogenesis for the analysis of sporadic and inflammation-driven tumor progression. *Nat Protoc* 2007, 2(8):1998-2004.
149. Suzuki R, Kohno H, Sugie S, Tanaka T: Dose-dependent promoting effect of dextran sodium sulfate on mouse colon carcinogenesis initiated with azoxymethane. *Histol Histopathol* 2005, 20(2):483-492.
150. Colotta F, Allavena P, Sica A, Garlanda C, Mantovani A: Cancer-related inflammation, the seventh hallmark of cancer: links to genetic instability. *Carcinogenesis* 2009, 30(7):1073-1081.
151. Yang L, Belaguli N, Berger DH: MicroRNA and colorectal cancer. *World J Surg* 2009, 33(4):638-646.
152. Grady WM, Carethers JM: Genomic and epigenetic instability in colorectal cancer pathogenesis. *Gastroenterology* 2008, 135(4):1079-1099.
153. Sabates-Bellver J, Van der Flier LG, de Palo M, Cattaneo E, Maake C, Rehrauer H, Laczko E, Kurowski MA, Bujnicki JM, Menigatti M et al: Transcriptome profile of human colorectal adenomas. *Mol Cancer Res* 2007, 5(12):1263-1275.
154. Cummins JM, He Y, Leary RJ, Pagliarini R, Diaz LA, Jr., Sjoblom T, Barad O, Bentwich Z, Szafranska AE, Labourier E et al: The colorectal microRNAome. *Proc Natl Acad Sci U S A* 2006, 103(10):3687-3692.
155. Oving IM, Clevers HC: Molecular causes of colon cancer. *Eur J Clin Invest* 2002, 32(6):448-457.
156. Hahn MA, Hahn T, Lee DH, Esworthy RS, Kim BW, Riggs AD, Chu FF, Pfeifer GP: Methylation of polycomb target genes in intestinal cancer is mediated by inflammation. *Cancer Res* 2008, 68(24):10280-10289.
157. Eads CA, Nickel AE, Laird PW: Complete genetic suppression of polyp formation and reduction of CpG-island hypermethylation in *Apc*(Min/+) *Dnmt1*-hypomorphic Mice. *Cancer Res* 2002, 62(5):1296-1299.
158. Podolsky DK: Inflammatory bowel disease (2). *N Engl J Med* 1991, 325(14):1008-1016.
159. Chung DC: The genetic basis of colorectal cancer: insights into critical pathways of tumorigenesis. *Gastroenterology* 2000, 119(3):854-865.
160. Itzkowitz S: Colon carcinogenesis in inflammatory bowel disease: applying molecular genetics to clinical practice. *J Clin Gastroenterol* 2003, 36(5 Suppl):S70-74; discussion S94-76.

161. Willenbacher RF, Aust DE, Chang CG, Zelman SJ, Ferrell LD, Moore DH, 2nd, Waldman FM: Genomic instability is an early event during the progression pathway of ulcerative-colitis-related neoplasia. *Am J Pathol* 1999, 154(6):1825-1830.
162. Suzuki H, Harpaz N, Tarmin L, Yin J, Jiang HY, Bell JD, Hontanosas M, Groisman GM, Abraham JM, Meltzer SJ: Microsatellite instability in ulcerative colitis-associated colorectal dysplasias and cancers. *Cancer Res* 1994, 54(18):4841-4844.
163. Tarmin L, Yin J, Harpaz N, Kozam M, Noordzij J, Antonio LB, Jiang HY, Chan O, Cymes K, Meltzer SJ: Adenomatous polyposis coli gene mutations in ulcerative colitis-associated dysplasias and cancers versus sporadic colon neoplasms. *Cancer Res* 1995, 55(10):2035-2038.
164. Brentnall TA, Crispin DA, Rabinovitch PS, Haggitt RC, Rubin CE, Stevens AC, Burmer GC: Mutations in the p53 gene: an early marker of neoplastic progression in ulcerative colitis. *Gastroenterology* 1994, 107(2):369-378.
165. Yin J, Harpaz N, Tong Y, Huang Y, Laurin J, Greenwald BD, Hontanosas M, Newkirk C, Meltzer SJ: p53 point mutations in dysplastic and cancerous ulcerative colitis lesions. *Gastroenterology* 1993, 104(6):1633-1639.
166. Ezaki T, Watanabe M, Inoue N, Kanai T, Ogata H, Iwao Y, Ishii H, Hibi T: A specific genetic alteration on chromosome 6 in ulcerative colitis-associated colorectal cancers. *Cancer Res* 2003, 63(13):3747-3749.
167. Mikami T, Yoshida T, Akino F, Motoori T, Yajima M, Okayasu I: Apoptosis regulation differs between ulcerative colitis-associated and sporadic colonic tumors. Association with survivin and bcl-2. *Am J Clin Pathol* 2003, 119(5):723-730.
168. Sato F, Shibata D, Harpaz N, Xu Y, Yin J, Mori Y, Wang S, Olaru A, Deacu E, Selaru FM et al: Aberrant methylation of the HPP1 gene in ulcerative colitis-associated colorectal carcinoma. *Cancer Res* 2002, 62(23):6820-6822.
169. Azarschab P, Porschen R, Gregor M, Blin N, Holzmann K: Epigenetic control of the E-cadherin gene (CDH1) by CpG methylation in colectomy samples of patients with ulcerative colitis. *Genes Chromosomes Cancer* 2002, 35(2):121-126.
170. Lashner BA, Bauer WM, Rybicki LA, Goldblum JR: Abnormal p53 immunohistochemistry is associated with an increased colorectal cancer-related mortality in patients with ulcerative colitis. *Am J Gastroenterol* 2003, 98(6):1423-1427.
171. Karin M: How NF-kappaB is activated: the role of the IkappaB kinase (IKK) complex. *Oncogene* 1999, 18(49):6867-6874.

172. Thanos D, Maniatis T: NF-kappa B: a lesson in family values. *Cell* 1995, 80(4):529-532.
173. Lee H, Herrmann A, Deng JH, Kujawski M, Niu G, Li Z, Forman S, Jove R, Pardoll DM, Yu H: Persistently activated Stat3 maintains constitutive NF-kappaB activity in tumors. *Cancer Cell* 2009, 15(4):283-293.
174. Baeuerle PA: Pro-inflammatory signaling: last pieces in the NF-kappaB puzzle? *Curr Biol* 1998, 8(1):R19-22.
175. Perkins ND: NF-kappaB: tumor promoter or suppressor? *Trends Cell Biol* 2004, 14(2):64-69.
176. Karin M, Cao Y, Greten FR, Li ZW: NF-kappaB in cancer: from innocent bystander to major culprit. *Nat Rev Cancer* 2002, 2(4):301-310.
177. Fan C, Yang J, Engelhardt JF: Temporal pattern of NFkappaB activation influences apoptotic cell fate in a stimuli-dependent fashion. *J Cell Sci* 2002, 115(Pt 24):4843-4853.
178. Wang CY, Cusack JC, Jr., Liu R, Baldwin AS, Jr.: Control of inducible chemoresistance: enhanced anti-tumor therapy through increased apoptosis by inhibition of NF-kappaB. *Nat Med* 1999, 5(4):412-417.
179. Tergaonkar V, Pando M, Vafa O, Wahl G, Verma I: p53 stabilization is decreased upon NFkappaB activation: a role for NFkappaB in acquisition of resistance to chemotherapy. *Cancer Cell* 2002, 1(5):493-503.
180. Campbell KJ, Rocha S, Perkins ND: Active repression of antiapoptotic gene expression by RelA(p65) NF-kappa B. *Mol Cell* 2004, 13(6):853-865.
181. Ryan KM, Ernst MK, Rice NR, Vousden KH: Role of NF-kappaB in p53-mediated programmed cell death. *Nature* 2000, 404(6780):892-897.
182. Karin M, Greten FR: NF-kappaB: linking inflammation and immunity to cancer development and progression. *Nat Rev Immunol* 2005, 5(10):749-759.
183. Kojima M, Morisaki T, Sasaki N, Nakano K, Mibu R, Tanaka M, Katano M: Increased nuclear factor-kB activation in human colorectal carcinoma and its correlation with tumor progression. *Anticancer Res* 2004, 24(2B):675-681.
184. Naugler WE, Karin M: NF-kappaB and cancer-identifying targets and mechanisms. *Curr Opin Genet Dev* 2008, 18(1):19-26.
185. Meylan E, Dooley AL, Feldser DM, Shen L, Turk E, Ouyang C, Jacks T: Requirement for NF-kappaB signalling in a mouse model of lung adenocarcinoma. *Nature* 2009, 462(7269):104-107.

186. Wang CY, Mayo MW, Baldwin AS, Jr.: TNF- and cancer therapy-induced apoptosis: potentiation by inhibition of NF-kappaB. *Science* 1996, 274(5288):784-787.
187. Rogler G, Brand K, Vogl D, Page S, Hofmeister R, Andus T, Knuechel R, Baeuerle PA, Scholmerich J, Gross V: Nuclear factor kappaB is activated in macrophages and epithelial cells of inflamed intestinal mucosa. *Gastroenterology* 1998, 115(2):357-369.
188. Neurath MF, Pettersson S, Meyer zum Buschenfelde KH, Strober W: Local administration of antisense phosphorothioate oligonucleotides to the p65 subunit of NF-kappa B abrogates established experimental colitis in mice. *Nat Med* 1996, 2(9):998-1004.
189. Eckmann L, Nebelsiek T, Fingerle AA, Dann SM, Mages J, Lang R, Robine S, Kagnoff MF, Schmid RM, Karin M et al: Opposing functions of IKKbeta during acute and chronic intestinal inflammation. *Proc Natl Acad Sci U S A* 2008, 105(39):15058-15063.
190. Majumdar S, Aggarwal BB: Methotrexate suppresses NF-kappaB activation through inhibition of IkappaBalpha phosphorylation and degradation. *J Immunol* 2001, 167(5):2911-2920.
191. Greten FR, Eckmann L, Greten TF, Park JM, Li ZW, Egan LJ, Kagnoff MF, Karin M: IKKbeta links inflammation and tumorigenesis in a mouse model of colitis-associated cancer. *Cell* 2004, 118(3):285-296.
192. Kim S, Keku TO, Martin C, Galanko J, Woosley JT, Schroeder JC, Satia JA, Halabi S, Sandler RS: Circulating levels of inflammatory cytokines and risk of colorectal adenomas. *Cancer Res* 2008, 68(1):323-328.
193. Koehne CH, Dubois RN: COX-2 inhibition and colorectal cancer. *Semin Oncol* 2004, 31(2 Suppl 7):12-21.
194. Eberhart CE, Coffey RJ, Radhika A, Giardiello FM, Ferrenbach S, DuBois RN: Up-regulation of cyclooxygenase 2 gene expression in human colorectal adenomas and adenocarcinomas. *Gastroenterology* 1994, 107(4):1183-1188.
195. Sinicrope FA, Lemoine M, Xi L, Lynch PM, Cleary KR, Shen Y, Frazier ML: Reduced expression of cyclooxygenase 2 proteins in hereditary nonpolyposis colorectal cancers relative to sporadic cancers. *Gastroenterology* 1999, 117(2):350-358.
196. Dixon DA: Regulation of COX-2 expression in human cancers. *Prog Exp Tumor Res* 2003, 37:52-71.

197. Sano H, Kawahito Y, Wilder RL, Hashiramoto A, Mukai S, Asai K, Kimura S, Kato H, Kondo M, Hla T: Expression of cyclooxygenase-1 and -2 in human colorectal cancer. *Cancer Res* 1995, 55(17):3785-3789.
198. Kargman SL, O'Neill GP, Vickers PJ, Evans JF, Mancini JA, Jothy S: Expression of prostaglandin G/H synthase-1 and -2 protein in human colon cancer. *Cancer Res* 1995, 55(12):2556-2559.
199. Chulada PC, Thompson MB, Mahler JF, Doyle CM, Gaul BW, Lee C, Tiano HF, Morham SG, Smithies O, Langenbach R: Genetic disruption of Ptgs-1, as well as Ptgs-2, reduces intestinal tumorigenesis in Min mice. *Cancer Res* 2000, 60(17):4705-4708.
200. Oshima M, Dinchuk JE, Kargman SL, Oshima H, Hancock B, Kwong E, Trzaskos JM, Evans JF, Taketo MM: Suppression of intestinal polyposis in Apc delta716 knockout mice by inhibition of cyclooxygenase 2 (COX-2). *Cell* 1996, 87(5):803-809.
201. Al-Salihi MA, Terrece Pearman A, Doan T, Reichert EC, Rosenberg DW, Prescott SM, Stafforini DM, Topham MK: Transgenic expression of cyclooxygenase-2 in mouse intestine epithelium is insufficient to initiate tumorigenesis but promotes tumor progression. *Cancer Lett* 2009, 273(2):225-232.
202. Muller-Decker K, Neufang G, Berger I, Neumann M, Marks F, Furstenberger G: Transgenic cyclooxygenase-2 overexpression sensitizes mouse skin for carcinogenesis. *Proc Natl Acad Sci U S A* 2002, 99(19):12483-12488.
203. Leung WK, Wu KC, Wong CY, Cheng AS, Ching AK, Chan AW, Chong WW, Go MY, Yu J, To KF et al: Transgenic cyclooxygenase-2 expression and high salt enhanced susceptibility to chemical-induced gastric cancer development in mice. *Carcinogenesis* 2008, 29(8):1648-1654.
204. Kawamori T, Uchiya N, Sugimura T, Wakabayashi K: Enhancement of colon carcinogenesis by prostaglandin E2 administration. *Carcinogenesis* 2003, 24(5):985-990.
205. Yan M, Rerko RM, Platzer P, Dawson D, Willis J, Tong M, Lawrence E, Lutterbaugh J, Lu S, Willson JK et al: 15-Hydroxyprostaglandin dehydrogenase, a COX-2 oncogene antagonist, is a TGF-beta-induced suppressor of human gastrointestinal cancers. *Proc Natl Acad Sci U S A* 2004, 101(50):17468-17473.
206. Backlund MG, Mann JR, Holla VR, Buchanan FG, Tai HH, Musiek ES, Milne GL, Katkuri S, DuBois RN: 15-Hydroxyprostaglandin dehydrogenase is down-regulated in colorectal cancer. *J Biol Chem* 2005, 280(5):3217-3223.

207. Ding Y, Tong M, Liu S, Moscow JA, Tai HH: NAD⁺-linked 15-hydroxyprostaglandin dehydrogenase (15-PGDH) behaves as a tumor suppressor in lung cancer. *Carcinogenesis* 2005, 26(1):65-72.
208. Myung SJ, Rerko RM, Yan M, Platzer P, Guda K, Dotson A, Lawrence E, Dannenberg AJ, Lovgren AK, Luo G et al: 15-Hydroxyprostaglandin dehydrogenase is an in vivo suppressor of colon tumorigenesis. *Proc Natl Acad Sci U S A* 2006, 103(32):12098-12102.
209. Mann JR, Backlund MG, Buchanan FG, Daikoku T, Holla VR, Rosenberg DW, Dey SK, DuBois RN: Repression of prostaglandin dehydrogenase by epidermal growth factor and snail increases prostaglandin E2 and promotes cancer progression. *Cancer Res* 2006, 66(13):6649-6656.
210. Hansen-Petrik MB, McEntee MF, Jull B, Shi H, Zemel MB, Whelan J: Prostaglandin E(2) protects intestinal tumors from nonsteroidal anti-inflammatory drug-induced regression in Apc(Min/+) mice. *Cancer Res* 2002, 62(2):403-408.
211. Jaffe BM, Parker CW, Philpott GW: Immunochemical measurement of prostaglandin or prostaglandin-like activity from normal and neoplastic cultured tissue. *Surg Forum* 1971, 22:90-92.
212. Sonoshita M, Takaku K, Oshima M, Sugihara K, Taketo MM: Cyclooxygenase-2 expression in fibroblasts and endothelial cells of intestinal polyps. *Cancer Res* 2002, 62(23):6846-6849.
213. Mutoh M, Watanabe K, Kitamura T, Shoji Y, Takahashi M, Kawamori T, Tani K, Kobayashi M, Maruyama T, Kobayashi K et al: Involvement of prostaglandin E receptor subtype EP(4) in colon carcinogenesis. *Cancer Res* 2002, 62(1):28-32.
214. Amano H, Hayashi I, Endo H, Kitasato H, Yamashina S, Maruyama T, Kobayashi M, Satoh K, Narita M, Sugimoto Y et al: Host prostaglandin E(2)-EP3 signaling regulates tumor-associated angiogenesis and tumor growth. *J Exp Med* 2003, 197(2):221-232.
215. Chang SH, Liu CH, Conway R, Han DK, Nithipatikom K, Trifan OC, Lane TF, Hla T: Role of prostaglandin E2-dependent angiogenic switch in cyclooxygenase 2-induced breast cancer progression. *Proc Natl Acad Sci U S A* 2004, 101(2):591-596.
216. Cha YI, DuBois RN: NSAIDs and cancer prevention: targets downstream of COX-2. *Annu Rev Med* 2007, 58:239-252.
217. Castellone MD, Teramoto H, Williams BO, Druey KM, Gutkind JS: Prostaglandin E2 promotes colon cancer cell growth through a Gs-axin-beta-catenin signaling axis. *Science* 2005, 310(5753):1504-1510.

218. Shao J, Jung C, Liu C, Sheng H: Prostaglandin E2 Stimulates the beta-catenin/T cell factor-dependent transcription in colon cancer. *J Biol Chem* 2005, 280(28):26565-26572.
219. He TC, Chan TA, Vogelstein B, Kinzler KW: PPARdelta is an APC-regulated target of nonsteroidal anti-inflammatory drugs. *Cell* 1999, 99(3):335-345.
220. Buchanan FG, Gorden DL, Matta P, Shi Q, Matrisian LM, DuBois RN: Role of beta-arrestin 1 in the metastatic progression of colorectal cancer. *Proc Natl Acad Sci U S A* 2006, 103(5):1492-1497.
221. Chell SD, Witherden IR, Dobson RR, Moorghen M, Herman AA, Qualtrough D, Williams AC, Paraskeva C: Increased EP4 receptor expression in colorectal cancer progression promotes cell growth and anchorage independence. *Cancer Res* 2006, 66(6):3106-3113.
222. Ma X, Kundu N, Rifat S, Walser T, Fulton AM: Prostaglandin E receptor EP4 antagonism inhibits breast cancer metastasis. *Cancer Res* 2006, 66(6):2923-2927.
223. Dannenberg AJ, Lippman SM, Mann JR, Subbaramaiah K, DuBois RN: Cyclooxygenase-2 and epidermal growth factor receptor: pharmacologic targets for chemoprevention. *J Clin Oncol* 2005, 23(2):254-266.
224. Shao J, Lee SB, Guo H, Evers BM, Sheng H: Prostaglandin E2 stimulates the growth of colon cancer cells via induction of amphiregulin. *Cancer Res* 2003, 63(17):5218-5223.
225. Buchanan FG, Wang D, Bargiacchi F, DuBois RN: Prostaglandin E2 regulates cell migration via the intracellular activation of the epidermal growth factor receptor. *J Biol Chem* 2003, 278(37):35451-35457.
226. Pai R, Soreghan B, Szabo IL, Pavelka M, Baatar D, Tarnawski AS: Prostaglandin E2 transactivates EGF receptor: a novel mechanism for promoting colon cancer growth and gastrointestinal hypertrophy. *Nat Med* 2002, 8(3):289-293.
227. Vogelstein B, Kinzler KW: Cancer genes and the pathways they control. *Nat Med* 2004, 10(8):789-799.
228. Jones MK, Wang H, Peskar BM, Levin E, Itani RM, Sarfeh IJ, Tarnawski AS: Inhibition of angiogenesis by nonsteroidal anti-inflammatory drugs: insight into mechanisms and implications for cancer growth and ulcer healing. *Nat Med* 1999, 5(12):1418-1423.
229. Tsujii M, Kawano S, DuBois RN: Cyclooxygenase-2 expression in human colon cancer cells increases metastatic potential. *Proc Natl Acad Sci U S A* 1997, 94(7):3336-3340.

230. Khayrullina T, Yen JH, Jing H, Ganea D: In vitro differentiation of dendritic cells in the presence of prostaglandin E2 alters the IL-12/IL-23 balance and promotes differentiation of Th17 cells. *J Immunol* 2008, 181(1):721-735.
231. Wu Y, Zhou BP: Inflammation: a driving force speeds cancer metastasis. *Cell Cycle* 2009, 8(20):3267-3273.
232. Wang S, Liu Z, Wang L, Zhang X: NF-kappaB signaling pathway, inflammation and colorectal cancer. *Cell Mol Immunol* 2009, 6(5):327-334.
233. Klampfer L: The role of signal transducers and activators of transcription in colon cancer. *Front Biosci* 2008, 13:2888-2899.
234. Wu Y, Deng J, Rychahou PG, Qiu S, Evers BM, Zhou BP: Stabilization of snail by NF-kappaB is required for inflammation-induced cell migration and invasion. *Cancer Cell* 2009, 15(5):416-428.
235. Yang J, Weinberg RA: Epithelial-mesenchymal transition: at the crossroads of development and tumor metastasis. *Dev Cell* 2008, 14(6):818-829.
236. Voronov E, Shouval DS, Krelin Y, Cagnano E, Benharroch D, Iwakura Y, Dinarello CA, Apte RN: IL-1 is required for tumor invasiveness and angiogenesis. *Proc Natl Acad Sci U S A* 2003, 100(5):2645-2650.
237. Yu H, Kortylewski M, Pardoll D: Crosstalk between cancer and immune cells: role of STAT3 in the tumour microenvironment. *Nat Rev Immunol* 2007, 7(1):41-51.
238. Zucker S, Vacirca J: Role of matrix metalloproteinases (MMPs) in colorectal cancer. *Cancer Metastasis Rev* 2004, 23(1-2):101-117.
239. Mauchley DC, Lynge DC, Langdale LA, Stelzner MG, Mock CN, Billingsley KG: Clinical utility and cost-effectiveness of routine preoperative computed tomography scanning in patients with colon cancer. *Am J Surg* 2005, 189(5):512-517; discussion 517.
240. Copel L, Sosna J, Kruskal JB, Raptopoulos V, Farrell RJ, Morrin MM: CT colonography in 546 patients with incomplete colonoscopy. *Radiology* 2007, 244(2):471-478.
241. Mainenti PP, Romano M, Imbriaco M, Camera L, Pace L, D'Antonio D, Bucci L, Galloro G, Salvatore M: Added value of CT colonography after a positive conventional colonoscopy: impact on treatment strategy. *Abdom Imaging* 2005, 30(1):42-47.

242. Ward DG, Suggett N, Cheng Y, Wei W, Johnson H, Billingham LJ, Ismail T, Wakelam MJ, Johnson PJ, Martin A: Identification of serum biomarkers for colon cancer by proteomic analysis. *Br J Cancer* 2006, 94(12):1898-1905.
243. Fletcher RH: Carcinoembryonic antigen. *Ann Intern Med* 1986, 104(1):66-73.
244. Petrioli R, Licchetta A, Roviello G, Pascucci A, Francini E, Bargagli G, Conca R, Miano ST, Marzocca G, Francini G: CEA and CA19.9 as early predictors of progression in advanced/metastatic colorectal cancer patients receiving oxaliplatin-based chemotherapy and bevacizumab. *Cancer Invest* 2012, 30(1):65-71.
245. Labianca R, Beretta GD, Kildani B, Milesi L, Merlin F, Mosconi S, Pessi MA, Prochilo T, Quadri A, Gatta G et al: Colon cancer. *Crit Rev Oncol Hematol* 2010, 74(2):106-133.
246. Ueno H, Mochizuki H, Akagi Y, Kusumi T, Yamada K, Ikegami M, Kawachi H, Kameoka S, Ohkura Y, Masaki T et al: Optimal Colorectal Cancer Staging Criteria in TNM Classification. *J Clin Oncol* 2012.
247. Hu H, Krasinskas A, Willis J: Perspectives on current tumor-node-metastasis (TNM) staging of cancers of the colon and rectum. *Semin Oncol* 2011, 38(4):500-510.
248. Newland RC, Chapuis PH, Pheils MT, MacPherson JG: The relationship of survival to staging and grading of colorectal carcinoma: a prospective study of 503 cases. *Cancer* 1981, 47(6):1424-1429.
249. Olson RM, Perencevich NP, Malcolm AW, Chaffey JT, Wilson RE: Patterns of recurrence following curative resection of adenocarcinoma of the colon and rectum. *Cancer* 1980, 45(12):2969-2974.
250. Van Cutsem E, Dicato M, Wils J, Cunningham D, Diaz-Rubio E, Glimelius B, Haller D, Johnston P, Kerr D, Koehne CH et al: Adjuvant treatment of colorectal cancer (current expert opinion derived from the Third International Conference: Perspectives in Colorectal Cancer, Dublin, 2001). *Eur J Cancer* 2002, 38(11):1429-1436.
251. Le Voyer TE, Sigurdson ER, Hanlon AL, Mayer RJ, Macdonald JS, Catalano PJ, Haller DG: Colon cancer survival is associated with increasing number of lymph nodes analyzed: a secondary survey of intergroup trial INT-0089. *J Clin Oncol* 2003, 21(15):2912-2919.
252. Prandi M, Lionetto R, Bini A, Francioni G, Accarpio G, Anfossi A, Ballario E, Becchi G, Bonilauri S, Carobbi A et al: Prognostic evaluation of stage B colon cancer patients is improved by an adequate lymphadenectomy: results of a secondary analysis of a large scale adjuvant trial. *Ann Surg* 2002, 235(4):458-463.

253. Cunningham D, Humblet Y, Siena S, Khayat D, Bleiberg H, Santoro A, Bets D, Mueser M, Harstrick A, Verslype C et al: Cetuximab monotherapy and cetuximab plus irinotecan in irinotecan-refractory metastatic colorectal cancer. *N Engl J Med* 2004, 351(4):337-345.
254. Hurwitz H, Fehrenbacher L, Novotny W, Cartwright T, Hainsworth J, Heim W, Berlin J, Baron A, Griffing S, Holmgren E et al: Bevacizumab plus irinotecan, fluorouracil, and leucovorin for metastatic colorectal cancer. *N Engl J Med* 2004, 350(23):2335-2342.
255. Giacchetti S, Perpoint B, Zidani R, Le Bail N, Faggiuolo R, Focan C, Chollet P, Llory JF, Letourneau Y, Coudert B et al: Phase III multicenter randomized trial of oxaliplatin added to chronomodulated fluorouracil-leucovorin as first-line treatment of metastatic colorectal cancer. *J Clin Oncol* 2000, 18(1):136-147.
256. Wagman LD, Kemeny MM, Leong L, Terz JJ, Hill LR, Beatty JD, Kokal WA, Riihimaki DU: A prospective, randomized evaluation of the treatment of colorectal cancer metastatic to the liver. *J Clin Oncol* 1990, 8(11):1885-1893.
257. Tournigand C, Andre T, Achille E, Lledo G, Flesh M, Mery-Mignard D, Quinaux E, Couteau C, Buyse M, Ganem G et al: FOLFIRI followed by FOLFOX6 or the reverse sequence in advanced colorectal cancer: a randomized GERCOR study. *J Clin Oncol* 2004, 22(2):229-237.
258. Cassidy J, Clarke S, Diaz-Rubio E, Scheithauer W, Figer A, Wong R, Koski S, Lichinitser M, Yang TS, Rivera F et al: Randomized phase III study of capecitabine plus oxaliplatin compared with fluorouracil/folinic acid plus oxaliplatin as first-line therapy for metastatic colorectal cancer. *J Clin Oncol* 2008, 26(12):2006-2012.
259. Porschen R, Arkenau HT, Kubicka S, Greil R, Seufferlein T, Freier W, Kretzschmar A, Graeven U, Grothey A, Hinke A et al: Phase III study of capecitabine plus oxaliplatin compared with fluorouracil and leucovorin plus oxaliplatin in metastatic colorectal cancer: a final report of the AIO Colorectal Study Group. *J Clin Oncol* 2007, 25(27):4217-4223.
260. Grothey A, Sargent D, Goldberg RM, Schmoll HJ: Survival of patients with advanced colorectal cancer improves with the availability of fluorouracil-leucovorin, irinotecan, and oxaliplatin in the course of treatment. *J Clin Oncol* 2004, 22(7):1209-1214.
261. Cunningham D, Sirohi B, Pluzanska A, Utracka-Hutka B, Zaluski J, Glynne-Jones R, Koralewski P, Bridgewater J, Mainwaring P, Wasan H et al: Two different first-line 5-fluorouracil regimens with or without oxaliplatin in patients with metastatic colorectal cancer. *Ann Oncol* 2009, 20(2):244-250.

262. Seymour MT, Maughan TS, Ledermann JA, Topham C, James R, Gwyther SJ, Smith DB, Shepherd S, Maraveyas A, Ferry DR et al: Different strategies of sequential and combination chemotherapy for patients with poor prognosis advanced colorectal cancer (MRC FOCUS): a randomised controlled trial. *Lancet* 2007, 370(9582):143-152.
263. Tournigand C, Cervantes A, Figuer A, Lledo G, Flesch M, Buyse M, Mineur L, Carola E, Etienne PL, Rivera F et al: OPTIMOX1: a randomized study of FOLFOX4 or FOLFOX7 with oxaliplatin in a stop-and-Go fashion in advanced colorectal cancer--a GERCOR study. *J Clin Oncol* 2006, 24(3):394-400.
264. Maughan TS, James RD, Kerr DJ, Ledermann JA, Seymour MT, Topham C, McArdle C, Cain D, Stephens RJ: Comparison of intermittent and continuous palliative chemotherapy for advanced colorectal cancer: a multicentre randomised trial. *Lancet* 2003, 361(9356):457-464.
265. Wilke H, Glynne-Jones R, Thaler J, Adenis A, Preusser P, Aguilar EA, Apro MS, Esser R, Loos AH, Siena S: Cetuximab plus irinotecan in heavily pretreated metastatic colorectal cancer progressing on irinotecan: MABEL Study. *J Clin Oncol* 2008, 26(33):5335-5343.
266. Sobrero AF, Maurel J, Fehrenbacher L, Scheithauer W, Abubakr YA, Lutz MP, Vega-Villegas ME, Eng C, Steinhauer EU, Prausova J et al: EPIC: phase III trial of cetuximab plus irinotecan after fluoropyrimidine and oxaliplatin failure in patients with metastatic colorectal cancer. *J Clin Oncol* 2008, 26(14):2311-2319.
267. Van Cutsem E, Kohne CH, Hitre E, Zaluski J, Chang Chien CR, Makhson A, D'Haens G, Pinter T, Lim R, Bodoky G et al: Cetuximab and chemotherapy as initial treatment for metastatic colorectal cancer. *N Engl J Med* 2009, 360(14):1408-1417.
268. Douillard JY, Siena S, Cassidy J, Tabernero J, Burkes R, Barugel M, Humblet Y, Bodoky G, Cunningham D, Jassem J et al: Randomized, phase III trial of panitumumab with infusional fluorouracil, leucovorin, and oxaliplatin (FOLFOX4) versus FOLFOX4 alone as first-line treatment in patients with previously untreated metastatic colorectal cancer: the PRIME study. *J Clin Oncol* 2010, 28(31):4697-4705.
269. Van Cutsem E, Peeters M, Siena S, Humblet Y, Hendlisz A, Neyns B, Canon JL, Van Laethem JL, Maurel J, Richardson G et al: Open-label phase III trial of panitumumab plus best supportive care compared with best supportive care alone in patients with chemotherapy-refractory metastatic colorectal cancer. *J Clin Oncol* 2007, 25(13):1658-1664.

270. Peeters M, Price TJ, Cervantes A, Sobrero AF, Ducreux M, Hotko Y, Andre T, Chan E, Lordick F, Punt CJ et al: Randomized phase III study of panitumumab with fluorouracil, leucovorin, and irinotecan (FOLFIRI) compared with FOLFIRI alone as second-line treatment in patients with metastatic colorectal cancer. *J Clin Oncol* 2010, 28(31):4706-4713.
271. Paez JG, Janne PA, Lee JC, Tracy S, Greulich H, Gabriel S, Herman P, Kaye FJ, Lindeman N, Boggon TJ et al: EGFR mutations in lung cancer: correlation with clinical response to gefitinib therapy. *Science* 2004, 304(5676):1497-1500.
272. Lynch TJ, Bell DW, Sordella R, Gurubhagavatula S, Okimoto RA, Brannigan BW, Harris PL, Haserlat SM, Supko JG, Haluska FG et al: Activating mutations in the epidermal growth factor receptor underlying responsiveness of non-small-cell lung cancer to gefitinib. *N Engl J Med* 2004, 350(21):2129-2139.
273. Aparo S, Goel S: Evolvement of the treatment paradigm for metastatic colon cancer. From chemotherapy to targeted therapy. *Crit Rev Oncol Hematol* 2012, 83(1):47-58.
274. Thirion P, Michiels S, Pignon JP, Buyse M, Braud AC, Carlson RW, O'Connell M, Sargent P, Piedbois P: Modulation of fluorouracil by leucovorin in patients with advanced colorectal cancer: an updated meta-analysis. *J Clin Oncol* 2004, 22(18):3766-3775.
275. Efficacy of intravenous continuous infusion of fluorouracil compared with bolus administration in advanced colorectal cancer. Meta-analysis Group In Cancer. *J Clin Oncol* 1998, 16(1):301-308.
276. Colucci G, Gebbia V, Paoletti G, Giuliani F, Caruso M, Gebbia N, Carteni G, Agostara B, Pezzella G, Manzione L et al: Phase III randomized trial of FOLFIRI versus FOLFOX4 in the treatment of advanced colorectal cancer: a multicenter study of the Gruppo Oncologico Dell'Italia Meridionale. *J Clin Oncol* 2005, 23(22):4866-4875.
277. Goldberg RM, Sargent DJ, Morton RF, Fuchs CS, Ramanathan RK, Williamson SK, Findlay BP, Pitot HC, Alberts SR: A randomized controlled trial of fluorouracil plus leucovorin, irinotecan, and oxaliplatin combinations in patients with previously untreated metastatic colorectal cancer. *J Clin Oncol* 2004, 22(1):23-30.
278. de Gramont A, Figer A, Seymour M, Homerin M, Hmissi A, Cassidy J, Boni C, Cortes-Funes H, Cervantes A, Freyer G et al: Leucovorin and fluorouracil with or without oxaliplatin as first-line treatment in advanced colorectal cancer. *J Clin Oncol* 2000, 18(16):2938-2947.

279. Saltz LB, Cox JV, Blanke C, Rosen LS, Fehrenbacher L, Moore MJ, Maroun JA, Ackland SP, Locker PK, Pirotta N et al: Irinotecan plus fluorouracil and leucovorin for metastatic colorectal cancer. Irinotecan Study Group. *N Engl J Med* 2000, 343(13):905-914.
280. Douillard JY, Cunningham D, Roth AD, Navarro M, James RD, Karasek P, Jandik P, Iveson T, Carmichael J, Alakl M et al: Irinotecan combined with fluorouracil compared with fluorouracil alone as first-line treatment for metastatic colorectal cancer: a multicentre randomised trial. *Lancet* 2000, 355(9209):1041-1047.
281. Tassi E, Wellstein A: The angiogenic switch molecule, secreted FGF-binding protein, an indicator of early stages of pancreatic and colorectal adenocarcinoma. *Semin Oncol* 2006, 33(6 Suppl 11):S50-56.
282. Hicklin DJ, Ellis LM: Role of the vascular endothelial growth factor pathway in tumor growth and angiogenesis. *J Clin Oncol* 2005, 23(5):1011-1027.
283. El Zouhairi M, Charabaty A, Pishvaian MJ: Molecularly targeted therapy for metastatic colon cancer: proven treatments and promising new agents. *Gastrointest Cancer Res* 2011, 4(1):15-21.
284. Ferrara N: Role of vascular endothelial growth factor in physiologic and pathologic angiogenesis: therapeutic implications. *Semin Oncol* 2002, 29(6 Suppl 16):10-14.
285. Ferrara N, Davis-Smyth T: The biology of vascular endothelial growth factor. *Endocr Rev* 1997, 18(1):4-25.
286. Cascinu S, Staccioli MP, Gasparini G, Giordani P, Catalano V, Ghiselli R, Rossi C, Baldelli AM, Graziano F, Saba V et al: Expression of vascular endothelial growth factor can predict event-free survival in stage II colon cancer. *Clin Cancer Res* 2000, 6(7):2803-2807.
287. Lee JC, Chow NH, Wang ST, Huang SM: Prognostic value of vascular endothelial growth factor expression in colorectal cancer patients. *Eur J Cancer* 2000, 36(6):748-753.
288. Warren RS, Yuan H, Matli MR, Gillett NA, Ferrara N: Regulation by vascular endothelial growth factor of human colon cancer tumorigenesis in a mouse model of experimental liver metastasis. *J Clin Invest* 1995, 95(4):1789-1797.
289. Ellis LM: Mechanisms of action of bevacizumab as a component of therapy for metastatic colorectal cancer. *Semin Oncol* 2006, 33(5 Suppl 10):S1-7.
290. Prat A, Casado E, Cortes J: New approaches in angiogenic targeting for colorectal cancer. *World J Gastroenterol* 2007, 13(44):5857-5866.

291. Saltz LB, Clarke S, Diaz-Rubio E, Scheithauer W, Figer A, Wong R, Koski S, Lichinitser M, Yang TS, Rivera F et al: Bevacizumab in combination with oxaliplatin-based chemotherapy as first-line therapy in metastatic colorectal cancer: a randomized phase III study. *J Clin Oncol* 2008, 26(12):2013-2019.
292. Wang TF, Lockhart AC: Aflibercept in the treatment of metastatic colorectal cancer. *Clin Med Insights Oncol* 2012, 6:19-30.
293. Brave SR, Odedra R, James NH, Smith NR, Marshall GB, Acheson KL, Baker D, Howard Z, Jackson L, Ratcliffe K et al: Vandetanib inhibits both VEGFR-2 and EGFR signalling at clinically relevant drug levels in preclinical models of human cancer. *Int J Oncol* 2011, 39(1):271-278.
294. Sobrero AF, Bruzzi P: Vatalanib in advanced colorectal cancer: two studies with identical results. *J Clin Oncol* 2011, 29(15):1938-1940.
295. Saltz LB, Rosen LS, Marshall JL, Belt RJ, Hurwitz HI, Eckhardt SG, Bergsland EK, Haller DG, Lockhart AC, Rocha Lima CM et al: Phase II trial of sunitinib in patients with metastatic colorectal cancer after failure of standard therapy. *J Clin Oncol* 2007, 25(30):4793-4799.
296. Dreves J, Siegert P, Medinger M, Mross K, Strecker R, Zirrgiebel U, Harder J, Blum H, Robertson J, Jurgensmeier JM et al: Phase I clinical study of AZD2171, an oral vascular endothelial growth factor signaling inhibitor, in patients with advanced solid tumors. *J Clin Oncol* 2007, 25(21):3045-3054.
297. Rosen LS, Kurzrock R, Mulay M, Van Vugt A, Purdom M, Ng C, Silverman J, Koutsoukos A, Sun YN, Bass MB et al: Safety, pharmacokinetics, and efficacy of AMG 706, an oral multikinase inhibitor, in patients with advanced solid tumors. *J Clin Oncol* 2007, 25(17):2369-2376.
298. Herbst RS: Review of epidermal growth factor receptor biology. *Int J Radiat Oncol Biol Phys* 2004, 59(2 Suppl):21-26.
299. Marshall J: Clinical implications of the mechanism of epidermal growth factor receptor inhibitors. *Cancer* 2006, 107(6):1207-1218.
300. Gibson TB, Ranganathan A, Grothey A: Randomized phase III trial results of panitumumab, a fully human anti-epidermal growth factor receptor monoclonal antibody, in metastatic colorectal cancer. *Clin Colorectal Cancer* 2006, 6(1):29-31.
301. Hudes G, Carducci M, Tomczak P, Dutcher J, Figlin R, Kapoor A, Staroslawska E, Sosman J, McDermott D, Bodrogi I et al: Temsirolimus, interferon alfa, or both for advanced renal-cell carcinoma. *N Engl J Med* 2007, 356(22):2271-2281.

302. Tabernero J, Rojo F, Calvo E, Burris H, Judson I, Hazell K, Martinelli E, Ramon y Cajal S, Jones S, Vidal L et al: Dose- and schedule-dependent inhibition of the mammalian target of rapamycin pathway with everolimus: a phase I tumor pharmacodynamic study in patients with advanced solid tumors. *J Clin Oncol* 2008, 26(10):1603-1610.
303. Camidge DR, Gail Eckhardt S, Gore L, O'Bryant CL, Leong S, Basche M, Holden SN, Musib L, Baldwin J, Darstein C et al: A phase I safety, tolerability, and pharmacokinetic study of enzastaurin combined with capecitabine in patients with advanced solid tumors. *Anticancer Drugs* 2008, 19(1):77-84.
304. Carducci MA, Musib L, Kies MS, Pili R, Truong M, Brahmer JR, Cole P, Sullivan R, Riddle J, Schmidt J et al: Phase I dose escalation and pharmacokinetic study of enzastaurin, an oral protein kinase C beta inhibitor, in patients with advanced cancer. *J Clin Oncol* 2006, 24(25):4092-4099.
305. Summy JM, Gallick GE: Treatment for advanced tumors: SRC reclaims center stage. *Clin Cancer Res* 2006, 12(5):1398-1401.
306. Fujisaka Y, Onozawa Y, Kurata T, Yasui H, Goto I, Yamazaki K, Machida N, Watanabe J, Shimada H, Shi X et al: First report of the safety, tolerability, and pharmacokinetics of the Src kinase inhibitor saracatinib (AZD0530) in Japanese patients with advanced solid tumours. *Invest New Drugs* 2012.
307. Wood KW, Cornwell WD, Jackson JR: Past and future of the mitotic spindle as an oncology target. *Curr Opin Pharmacol* 2001, 1(4):370-377.
308. Luo L, Parrish CA, Nevins N, McNulty DE, Chaudhari AM, Carson JD, Sudakin V, Shaw AN, Lehr R, Zhao H et al: ATP-competitive inhibitors of the mitotic kinesin KSP that function via an allosteric mechanism. *Nat Chem Biol* 2007, 3(11):722-726.
309. Burris HA, 3rd, Jones SF, Williams DD, Kathman SJ, Hodge JP, Pandite L, Ho PT, Boerner SA, Lorusso P: A phase I study of ispinesib, a kinesin spindle protein inhibitor, administered weekly for three consecutive weeks of a 28-day cycle in patients with solid tumors. *Invest New Drugs* 2011, 29(3):467-472.
310. Thomas MC, Chiang CM: The general transcription machinery and general cofactors. *Crit Rev Biochem Mol Biol* 2006, 41(3):105-178.
311. Maston GA, Evans SK, Green MR: Transcriptional regulatory elements in the human genome. *Annu Rev Genomics Hum Genet* 2006, 7:29-59.
312. Mees C, Nemunaitis J, Senzer N: Transcription factors: their potential as targets for an individualized therapeutic approach to cancer. *Cancer Gene Ther* 2009, 16(2):103-112.

313. Liu Y, Ludes-Meyers J, Zhang Y, Munoz-Medellin D, Kim HT, Lu C, Ge G, Schiff R, Hilsenbeck SG, Osborne CK et al: Inhibition of AP-1 transcription factor causes blockade of multiple signal transduction pathways and inhibits breast cancer growth. *Oncogene* 2002, 21(50):7680-7689.
314. Eder IE, Hoffmann J, Rogatsch H, Schafer G, Zopf D, Bartsch G, Klocker H: Inhibition of LNCaP prostate tumor growth in vivo by an antisense oligonucleotide directed against the human androgen receptor. *Cancer Gene Ther* 2002, 9(2):117-125.
315. Jean D, Bar-Eli M: Targeting the ATF-1/CREB transcription factors by single chain Fv fragment in human melanoma: potential modality for cancer therapy. *Crit Rev Immunol* 2001, 21(1-3):275-286.
316. Dennis JH, Budhram-Mahadeo V, Latchman DS: The Brn-3b POU family transcription factor regulates the cellular growth, proliferation, and anchorage dependence of MCF7 human breast cancer cells. *Oncogene* 2001, 20(36):4961-4971.
317. Halmos B, Huettner CS, Kocher O, Ferenczi K, Karp DD, Tenen DG: Down-regulation and antiproliferative role of C/EBPalpha in lung cancer. *Cancer Res* 2002, 62(2):528-534.
318. Abramovitch R, Tavor E, Jacob-Hirsch J, Zeira E, Amariglio N, Pappo O, Rechavi G, Galun E, Honigman A: A pivotal role of cyclic AMP-responsive element binding protein in tumor progression. *Cancer Res* 2004, 64(4):1338-1346.
319. Wu L, Timmers C, Maiti B, Saavedra HI, Sang L, Chong GT, Nuckolls F, Giangrande P, Wright FA, Field SJ et al: The E2F1-3 transcription factors are essential for cellular proliferation. *Nature* 2001, 414(6862):457-462.
320. Hashiya N, Jo N, Aoki M, Matsumoto K, Nakamura T, Sato Y, Ogata N, Ogihara T, Kaneda Y, Morishita R: In vivo evidence of angiogenesis induced by transcription factor Ets-1: Ets-1 is located upstream of angiogenesis cascade. *Circulation* 2004, 109(24):3035-3041.
321. Takahashi A, Higashino F, Aoyagi M, Yoshida K, Itoh M, Kyo S, Ohno T, Taira T, Ariga H, Nakajima K et al: EWS/ETS fusions activate telomerase in Ewing's tumors. *Cancer Res* 2003, 63(23):8338-8344.
322. Lee RY, Hench J, Ruvkun G: Regulation of *C. elegans* DAF-16 and its human ortholog FKHRL1 by the *daf-2* insulin-like signaling pathway. *Curr Biol* 2001, 11(24):1950-1957.

323. Vincent KA, Shyu KG, Luo Y, Magner M, Tio RA, Jiang C, Goldberg MA, Akita GY, Gregory RJ, Isner JM: Angiogenesis is induced in a rabbit model of hindlimb ischemia by naked DNA encoding an HIF-1 α /VP16 hybrid transcription factor. *Circulation* 2000, 102(18):2255-2261.
324. Hatzi E, Murphy C, Zoepfel A, Rasmussen H, Morbidelli L, Ahorn H, Kunisada K, Tontsch U, Klenk M, Yamauchi-Takahara K et al: N-myc oncogene overexpression down-regulates IL-6; evidence that IL-6 inhibits angiogenesis and suppresses neuroblastoma tumor growth. *Oncogene* 2002, 21(22):3552-3561.
325. Richardson PG, Barlogie B, Berenson J, Singhal S, Jagannath S, Irwin D, Rajkumar SV, Srkalovic G, Alsina M, Alexanian R et al: A phase 2 study of bortezomib in relapsed, refractory myeloma. *N Engl J Med* 2003, 348(26):2609-2617.
326. Bieche I, Tozlu S, Girault I, Onody P, Driouch K, Vidaud M, Lidereau R: Expression of PEA3/E1AF/ETV4, an Ets-related transcription factor, in breast tumors: positive links to MMP2, NRG1 and CGB expression. *Carcinogenesis* 2004, 25(3):405-411.
327. Manshour T, Yang Y, Lin H, Stass SA, Glassman AB, Keating MJ, Albitar M: Downregulation of RAR alpha in mice by antisense transgene leads to a compensatory increase in RAR beta and RAR gamma and development of lymphoma. *Blood* 1997, 89(7):2507-2515.
328. Wei D, Wang L, He Y, Xiong HQ, Abbruzzese JL, Xie K: Celecoxib inhibits vascular endothelial growth factor expression in and reduces angiogenesis and metastasis of human pancreatic cancer via suppression of Sp1 transcription factor activity. *Cancer Res* 2004, 64(6):2030-2038.
329. Sun J, Blaskovich MA, Jove R, Livingston SK, Coppola D, Sebti SM: Cucurbitacin Q: a selective STAT3 activation inhibitor with potent antitumor activity. *Oncogene* 2005, 24(20):3236-3245.
330. Leong PL, Xi S, Drenning SD, Dyer KF, Wentzel AL, Lerner EC, Smithgall TE, Grandis JR: Differential function of STAT5 isoforms in head and neck cancer growth control. *Oncogene* 2002, 21(18):2846-2853.
331. Nishizaki M, Meyn RE, Levy LB, Atkinson EN, White RA, Roth JA, Ji L: Synergistic inhibition of human lung cancer cell growth by adenovirus-mediated wild-type p53 gene transfer in combination with docetaxel and radiation therapeutics in vitro and in vivo. *Clin Cancer Res* 2001, 7(9):2887-2897.

332. Arkin MR, Wells JA: Small-molecule inhibitors of protein-protein interactions: progressing towards the dream. *Nat Rev Drug Discov* 2004, 3(4):301-317.
333. Stein CA, Benimetskaya L, Mani S: Antisense strategies for oncogene inactivation. *Semin Oncol* 2005, 32(6):563-572.
334. Dykxhoorn DM, Palliser D, Lieberman J: The silent treatment: siRNAs as small molecule drugs. *Gene Ther* 2006, 13(6):541-552.
335. Barton BE, Murphy TF, Shu P, Huang HF, Meyenhofer M, Barton A: Novel single-stranded oligonucleotides that inhibit signal transducer and activator of transcription 3 induce apoptosis in vitro and in vivo in prostate cancer cell lines. *Mol Cancer Ther* 2004, 3(10):1183-1191.
336. Grandis JR, Drenning SD, Zeng Q, Watkins SC, Melhem MF, Endo S, Johnson DE, Huang L, He Y, Kim JD: Constitutive activation of Stat3 signaling abrogates apoptosis in squamous cell carcinogenesis in vivo. *Proc Natl Acad Sci U S A* 2000, 97(8):4227-4232.
337. Jing N, Zhu Q, Yuan P, Li Y, Mao L, Tweardy DJ: Targeting signal transducer and activator of transcription 3 with G-quartet oligonucleotides: a potential novel therapy for head and neck cancer. *Mol Cancer Ther* 2006, 5(2):279-286.
338. Jing N, Li Y, Xiong W, Sha W, Jing L, Tweardy DJ: G-quartet oligonucleotides: a new class of signal transducer and activator of transcription 3 inhibitors that suppresses growth of prostate and breast tumors through induction of apoptosis. *Cancer Res* 2004, 64(18):6603-6609.
339. Bouwman P, Philipsen S: Regulation of the activity of Sp1-related transcription factors. *Mol Cell Endocrinol* 2002, 195(1-2):27-38.
340. Schultz JR, Petz LN, Nardulli AM: Estrogen receptor alpha and Sp1 regulate progesterone receptor gene expression. *Mol Cell Endocrinol* 2003, 201(1-2):165-175.
341. Dong L, Wang W, Wang F, Stoner M, Reed JC, Harigai M, Samudio I, Kladder MP, Vyhldal C, Safe S: Mechanisms of transcriptional activation of bcl-2 gene expression by 17beta-estradiol in breast cancer cells. *J Biol Chem* 1999, 274(45):32099-32107.
342. Duan R, Porter W, Safe S: Estrogen-induced c-fos protooncogene expression in MCF-7 human breast cancer cells: role of estrogen receptor Sp1 complex formation. *Endocrinology* 1998, 139(4):1981-1990.
343. Murata Y, Kim HG, Rogers KT, Udvardia AJ, Horowitz JM: Negative regulation of Sp1 trans-activation is correlated with the binding of cellular proteins to the amino terminus of the Sp1 trans-activation domain. *J Biol Chem* 1994, 269(32):20674-20681.

344. Courey AJ, Tjian R: Analysis of Sp1 in vivo reveals multiple transcriptional domains, including a novel glutamine-rich activation motif. *Cell* 1988, 55(5):887-898.
345. Kingsley C, Winoto A: Cloning of GT box-binding proteins: a novel Sp1 multigene family regulating T-cell receptor gene expression. *Mol Cell Biol* 1992, 12(10):4251-4261.
346. Hagen G, Dennig J, Preiss A, Beato M, Suske G: Functional analyses of the transcription factor Sp4 reveal properties distinct from Sp1 and Sp3. *J Biol Chem* 1995, 270(42):24989-24994.
347. Pascal E, Tjian R: Different activation domains of Sp1 govern formation of multimers and mediate transcriptional synergism. *Genes Dev* 1991, 5(9):1646-1656.
348. Bakovic M, Waite KA, Vance DE: Functional significance of Sp1, Sp2, and Sp3 transcription factors in regulation of the murine CTP:phosphocholine cytidyltransferase alpha promoter. *J Lipid Res* 2000, 41(4):583-594.
349. Rotheneder H, Geymayer S, Haidweger E: Transcription factors of the Sp1 family: interaction with E2F and regulation of the murine thymidine kinase promoter. *J Mol Biol* 1999, 293(5):1005-1015.
350. Majello B, De Luca P, Lania L: Sp3 is a bifunctional transcription regulator with modular independent activation and repression domains. *J Biol Chem* 1997, 272(7):4021-4026.
351. Dennig J, Beato M, Suske G: An inhibitor domain in Sp3 regulates its glutamine-rich activation domains. *Embo J* 1996, 15(20):5659-5667.
352. Birnbaum MJ, van Wijnen AJ, Odgren PR, Last TJ, Suske G, Stein GS, Stein JL: Sp1 trans-activation of cell cycle regulated promoters is selectively repressed by Sp3. *Biochemistry* 1995, 34(50):16503-16508.
353. Strom AC, Forsberg M, Lillhager P, Westin G: The transcription factors Sp1 and Oct-1 interact physically to regulate human U2 snRNA gene expression. *Nucleic Acids Res* 1996, 24(11):1981-1986.
354. Karlseder J, Rotheneder H, Wintersberger E: Interaction of Sp1 with the growth- and cell cycle-regulated transcription factor E2F. *Mol Cell Biol* 1996, 16(4):1659-1667.
355. Pazin MJ, Sheridan PL, Cannon K, Cao Z, Keck JG, Kadonaga JT, Jones KA: NF-kappa B-mediated chromatin reconfiguration and transcriptional activation of the HIV-1 enhancer in vitro. *Genes Dev* 1996, 10(1):37-49.

356. Chiang CM, Roeder RG: Cloning of an intrinsic human TFIID subunit that interacts with multiple transcriptional activators. *Science* 1995, 267(5197):531-536.
357. Gill G, Pascal E, Tseng ZH, Tjian R: A glutamine-rich hydrophobic patch in transcription factor Sp1 contacts the dTAFII110 component of the Drosophila TFIID complex and mediates transcriptional activation. *Proc Natl Acad Sci U S A* 1994, 91(1):192-196.
358. Ryu S, Tjian R: Purification of transcription cofactor complex CRSP. *Proc Natl Acad Sci U S A* 1999, 96(13):7137-7142.
359. Ryu S, Zhou S, Ladurner AG, Tjian R: The transcriptional cofactor complex CRSP is required for activity of the enhancer-binding protein Sp1. *Nature* 1999, 397(6718):446-450.
360. Black AR, Black JD, Azizkhan-Clifford J: Sp1 and kruppel-like factor family of transcription factors in cell growth regulation and cancer. *J Cell Physiol* 2001, 188(2):143-160.
361. Philipsen S, Suske G: A tale of three fingers: the family of mammalian Sp/XKLF transcription factors. *Nucleic Acids Res* 1999, 27(15):2991-3000.
362. Gollner H, Bouwman P, Mangold M, Karis A, Braun H, Rohner I, Del Rey A, Besedovsky HO, Meinhardt A, van den Broek M et al: Complex phenotype of mice homozygous for a null mutation in the Sp4 transcription factor gene. *Genes Cells* 2001, 6(8):689-697.
363. Gollner H, Dani C, Phillips B, Philipsen S, Suske G: Impaired ossification in mice lacking the transcription factor Sp3. *Mech Dev* 2001, 106(1-2):77-83.
364. Marin M, Karis A, Visser P, Grosveld F, Philipsen S: Transcription factor Sp1 is essential for early embryonic development but dispensable for cell growth and differentiation. *Cell* 1997, 89(4):619-628.
365. Supp DM, Witte DP, Branford WW, Smith EP, Potter SS: Sp4, a member of the Sp1-family of zinc finger transcription factors, is required for normal murine growth, viability, and male fertility. *Dev Biol* 1996, 176(2):284-299.
366. Oh JE, Han JA, Hwang ES: Downregulation of transcription factor, Sp1, during cellular senescence. *Biochem Biophys Res Commun* 2007, 353(1):86-91.
367. Ammendola R, Mesuraca M, Russo T, Cimino F: Sp1 DNA binding efficiency is highly reduced in nuclear extracts from aged rat tissues. *J Biol Chem* 1992, 267(25):17944-17948.

368. Kanai M, Wei D, Li Q, Jia Z, Ajani J, Le X, Yao J, Xie K: Loss of Kruppel-like factor 4 expression contributes to Sp1 overexpression and human gastric cancer development and progression. *Clin Cancer Res* 2006, 12(21):6395-6402.
369. Safe S, Abdelrahim M: Sp transcription factor family and its role in cancer. *Eur J Cancer* 2005, 41(16):2438-2448.
370. Hosoi Y, Watanabe T, Nakagawa K, Matsumoto Y, Enomoto A, Morita A, Nagawa H, Suzuki N: Up-regulation of DNA-dependent protein kinase activity and Sp1 in colorectal cancer. *Int J Oncol* 2004, 25(2):461-468.
371. Shi Q, Le X, Abbruzzese JL, Peng Z, Qian CN, Tang H, Xiong Q, Wang B, Li XC, Xie K: Constitutive Sp1 activity is essential for differential constitutive expression of vascular endothelial growth factor in human pancreatic adenocarcinoma. *Cancer Res* 2001, 61(10):4143-4154.
372. Zannetti A, Del Vecchio S, Carriero MV, Fonti R, Franco P, Botti G, D'Aiuto G, Stoppelli MP, Salvatore M: Coordinate up-regulation of Sp1 DNA-binding activity and urokinase receptor expression in breast carcinoma. *Cancer Res* 2000, 60(6):1546-1551.
373. Lou Z, O'Reilly S, Liang H, Maher VM, Sleight SD, McCormick JJ: Down-regulation of overexpressed sp1 protein in human fibrosarcoma cell lines inhibits tumor formation. *Cancer Res* 2005, 65(3):1007-1017.
374. Yao JC, Wang L, Wei D, Gong W, Hassan M, Wu TT, Mansfield P, Ajani J, Xie K: Association between expression of transcription factor Sp1 and increased vascular endothelial growth factor expression, advanced stage, and poor survival in patients with resected gastric cancer. *Clin Cancer Res* 2004, 10(12 Pt 1):4109-4117.
375. Abdelrahim M, Baker CH, Abbruzzese JL, Sheikh-Hamad D, Liu S, Cho SD, Yoon K, Safe S: Regulation of vascular endothelial growth factor receptor-1 expression by specificity proteins 1, 3, and 4 in pancreatic cancer cells. *Cancer Res* 2007, 67(7):3286-3294.
376. Chiefari E, Brunetti A, Arturi F, Bidart JM, Russo D, Schlumberger M, Filetti S: Increased expression of AP2 and Sp1 transcription factors in human thyroid tumors: a role in NIS expression regulation? *BMC Cancer* 2002, 2:35.
377. Abdelrahim M, Samudio I, Smith R, 3rd, Burghardt R, Safe S: Small inhibitory RNA duplexes for Sp1 mRNA block basal and estrogen-induced gene expression and cell cycle progression in MCF-7 breast cancer cells. *J Biol Chem* 2002, 277(32):28815-28822.
378. Courey AJ, Holtzman DA, Jackson SP, Tjian R: Synergistic activation by the glutamine-rich domains of human transcription factor Sp1. *Cell* 1989, 59(5):827-836.

379. Hasleton MD, Ibbitt JC, Hurst HC: Characterization of the human activator protein-2gamma (AP-2gamma) gene: control of expression by Sp1/Sp3 in breast tumour cells. *Biochem J* 2003, 373(Pt 3):925-932.
380. Safe S, Kim K: Nuclear receptor-mediated transactivation through interaction with Sp proteins. *Prog Nucleic Acid Res Mol Biol* 2004, 77:1-36.
381. Pore N, Liu S, Shu HK, Li B, Haas-Kogan D, Stokoe D, Milanini-Mongiati J, Pages G, O'Rourke DM, Bernhard E et al: Sp1 is involved in Akt-mediated induction of VEGF expression through an HIF-1-independent mechanism. *Mol Biol Cell* 2004, 15(11):4841-4853.
382. Onishi T, Yamakawa K, Franco OE, Kawamura J, Watanabe M, Shiraishi T, Kitazawa S: Mitogen-activated protein kinase pathway is involved in alpha6 integrin gene expression in androgen-independent prostate cancer cells: role of proximal Sp1 consensus sequence. *Biochim Biophys Acta* 2001, 1538(2-3):218-227.
383. Banchio C, Schang LM, Vance DE: Phosphorylation of Sp1 by cyclin-dependent kinase 2 modulates the role of Sp1 in CTP:phosphocholine cytidyltransferase alpha regulation during the S phase of the cell cycle. *J Biol Chem* 2004, 279(38):40220-40226.
384. Fojas de Borja P, Collins NK, Du P, Azizkhan-Clifford J, Mudryj M: Cyclin A-CDK phosphorylates Sp1 and enhances Sp1-mediated transcription. *Embo J* 2001, 20(20):5737-5747.
385. Haidweger E, Novy M, Rotheneder H: Modulation of Sp1 activity by a cyclin A/CDK complex. *J Mol Biol* 2001, 306(2):201-212.
386. Huang W, Zhao S, Ammanamanchi S, Brattain M, Venkatasubbarao K, Freeman JW: Trichostatin A induces transforming growth factor beta type II receptor promoter activity and acetylation of Sp1 by recruitment of PCAF/p300 to a Sp1.NF-Y complex. *J Biol Chem* 2005, 280(11):10047-10054.
387. Ammanamanchi S, Freeman JW, Brattain MG: Acetylated sp3 is a transcriptional activator. *J Biol Chem* 2003, 278(37):35775-35780.
388. Torigoe T, Izumi H, Wakasugi T, Niina I, Igarashi T, Yoshida T, Shibuya I, Chijiwa K, Matsuo K, Itoh H et al: DNA topoisomerase II poison TAS-103 transactivates GC-box-dependent transcription via acetylation of Sp1. *J Biol Chem* 2005, 280(2):1179-1185.
389. Yang X, Su K, Roos MD, Chang Q, Paterson AJ, Kudlow JE: O-linkage of N-acetylglucosamine to Sp1 activation domain inhibits its transcriptional capability. *Proc Natl Acad Sci U S A* 2001, 98(12):6611-6616.

390. Stoner M, Wormke M, Saville B, Samudio I, Qin C, Abdelrahim M, Safe S: Estrogen regulation of vascular endothelial growth factor gene expression in ZR-75 breast cancer cells through interaction of estrogen receptor alpha and SP proteins. *Oncogene* 2004, 23(5):1052-1063.
391. Jennings R, Alsarraj M, Wright KL, Munoz-Antonia T: Regulation of the human transforming growth factor beta type II receptor gene promoter by novel Sp1 sites. *Oncogene* 2001, 20(47):6899-6909.
392. Ammanamanchi S, Brattain MG: Sp3 is a transcriptional repressor of transforming growth factor-beta receptors. *J Biol Chem* 2001, 276(5):3348-3352.
393. Liu Y, Zhong X, Li W, Brattain MG, Banerji SS: The role of Sp1 in the differential expression of transforming growth factor-beta receptor type II in human breast adenocarcinoma MCF-7 cells. *J Biol Chem* 2000, 275(16):12231-12236.
394. Khan S, Abdelrahim M, Samudio I, Safe S: Estrogen receptor/Sp1 complexes are required for induction of cad gene expression by 17beta-estradiol in breast cancer cells. *Endocrinology* 2003, 144(6):2325-2335.
395. Ngwenya S, Safe S: Cell context-dependent differences in the induction of E2F-1 gene expression by 17 beta-estradiol in MCF-7 and ZR-75 cells. *Endocrinology* 2003, 144(5):1675-1685.
396. Castro-Rivera E, Samudio I, Safe S: Estrogen regulation of cyclin D1 gene expression in ZR-75 breast cancer cells involves multiple enhancer elements. *J Biol Chem* 2001, 276(33):30853-30861.
397. Samudio I, Vyhldal C, Wang F, Stoner M, Chen I, Kladde M, Barhoumi R, Burghardt R, Safe S: Transcriptional activation of deoxyribonucleic acid polymerase alpha gene expression in MCF-7 cells by 17 beta-estradiol. *Endocrinology* 2001, 142(3):1000-1008.
398. Xie W, Duan R, Chen I, Samudio I, Safe S: Transcriptional activation of thymidylate synthase by 17beta-estradiol in MCF-7 human breast cancer cells. *Endocrinology* 2000, 141(7):2439-2449.
399. Xie W, Duan R, Safe S: Estrogen induces adenosine deaminase gene expression in MCF-7 human breast cancer cells: role of estrogen receptor-Sp1 interactions. *Endocrinology* 1999, 140(1):219-227.
400. Arinze IJ, Kawai Y: Sp family of transcription factors is involved in valproic acid-induced expression of Galphai2. *J Biol Chem* 2003, 278(20):17785-17791.
401. Zhu GH, Lenzi M, Schwartz EL: The Sp1 transcription factor contributes to the tumor necrosis factor-induced expression of the angiogenic factor thymidine phosphorylase in human colon carcinoma cells. *Oncogene* 2002, 21(55):8477-8485.

402. Wu J, Ling X, Pan D, Apontes P, Song L, Liang P, Altieri DC, Beerman T, Li F: Molecular mechanism of inhibition of survivin transcription by the GC-rich sequence-selective DNA binding antitumor agent, hedamycin: evidence of survivin down-regulation associated with drug sensitivity. *J Biol Chem* 2005, 280(10):9745-9751.
403. Chae YM, Park KK, Magae J, Lee IS, Kim CH, Kim HC, Hong S, Lee JG, Choi IJ, Kim HS et al: Sp1-decoy oligodeoxynucleotide inhibits high glucose-induced mesangial cell proliferation. *Biochem Biophys Res Commun* 2004, 319(2):550-555.
404. Ishibashi H, Nakagawa K, Onimaru M, Castellanos EJ, Kaneda Y, Nakashima Y, Shirasuna K, Sueishi K: Sp1 decoy transfected to carcinoma cells suppresses the expression of vascular endothelial growth factor, transforming growth factor beta1, and tissue factor and also cell growth and invasion activities. *Cancer Res* 2000, 60(22):6531-6536.
405. Borgatti M, Lampronti I, Romanelli A, Pedone C, Saviano M, Bianchi N, Mischiati C, Gambari R: Transcription factor decoy molecules based on a peptide nucleic acid (PNA)-DNA chimera mimicking Sp1 binding sites. *J Biol Chem* 2003, 278(9):7500-7509.
406. Xu X, Hamhouyia F, Thomas SD, Burke TJ, Girvan AC, McGregor WG, Trent JO, Miller DM, Bates PJ: Inhibition of DNA replication and induction of S phase cell cycle arrest by G-rich oligonucleotides. *J Biol Chem* 2001, 276(46):43221-43230.
407. Gately S, Li WW: Multiple roles of COX-2 in tumor angiogenesis: a target for antiangiogenic therapy. *Semin Oncol* 2004, 31(2 Suppl 7):2-11.
408. Taketo MM: Cyclooxygenase-2 inhibitors in tumorigenesis (Part II). *J Natl Cancer Inst* 1998, 90(21):1609-1620.
409. Taketo MM: Cyclooxygenase-2 inhibitors in tumorigenesis (part I). *J Natl Cancer Inst* 1998, 90(20):1529-1536.
410. Abdelrahim M, Safe S: Cyclooxygenase-2 inhibitors decrease vascular endothelial growth factor expression in colon cancer cells by enhanced degradation of Sp1 and Sp4 proteins. *Mol Pharmacol* 2005, 68(2):317-329.
411. Vane JR, Botting RM: Anti-inflammatory drugs and their mechanism of action. *Inflamm Res* 1998, 47 Suppl 2:S78-87.
412. Ulrich CM, Bigler J, Potter JD: Non-steroidal anti-inflammatory drugs for cancer prevention: promise, perils and pharmacogenetics. *Nat Rev Cancer* 2006, 6(2):130-140.

413. Vane JR, Flower RJ, Botting RM: History of aspirin and its mechanism of action. *Stroke* 1990, 21(12 Suppl):IV12-23.
414. Brown JR, DuBois RN: COX-2: a molecular target for colorectal cancer prevention. *J Clin Oncol* 2005, 23(12):2840-2855.
415. Rigas B, Goldman IS, Levine L: Altered eicosanoid levels in human colon cancer. *J Lab Clin Med* 1993, 122(5):518-523.
416. Rostom A, Dube C, Lewin G, Tsertsvadze A, Barrowman N, Code C, Sampson M, Moher D: Nonsteroidal anti-inflammatory drugs and cyclooxygenase-2 inhibitors for primary prevention of colorectal cancer: a systematic review prepared for the U.S. Preventive Services Task Force. *Ann Intern Med* 2007, 146(5):376-389.
417. Dube C, Rostom A, Lewin G, Tsertsvadze A, Barrowman N, Code C, Sampson M, Moher D: The use of aspirin for primary prevention of colorectal cancer: a systematic review prepared for the U.S. Preventive Services Task Force. *Ann Intern Med* 2007, 146(5):365-375.
418. Dai Y, Wang WH: Non-steroidal anti-inflammatory drugs in prevention of gastric cancer. *World J Gastroenterol* 2006, 12(18):2884-2889.
419. Thun MJ, Henley SJ, Patrono C: Nonsteroidal anti-inflammatory drugs as anticancer agents: mechanistic, pharmacologic, and clinical issues. *J Natl Cancer Inst* 2002, 94(4):252-266.
420. Baron JA, Sandler RS: Nonsteroidal anti-inflammatory drugs and cancer prevention. *Annu Rev Med* 2000, 51:511-523.
421. Gupta RA, DuBois RN: Aspirin, NSAIDS, and colon cancer prevention: mechanisms? *Gastroenterology* 1998, 114(5):1095-1098.
422. Schreinemachers DM, Everson RB: Aspirin use and lung, colon, and breast cancer incidence in a prospective study. *Epidemiology* 1994, 5(2):138-146.
423. Wang WH, Huang JQ, Zheng GF, Lam SK, Karlberg J, Wong BC: Non-steroidal anti-inflammatory drug use and the risk of gastric cancer: a systematic review and meta-analysis. *J Natl Cancer Inst* 2003, 95(23):1784-1791.
424. Baron JA: Aspirin and NSAIDs for the prevention of colorectal cancer. *Recent Results Cancer Res* 2009, 181:223-229.
425. Steinbach G, Lynch PM, Phillips RK, Wallace MH, Hawk E, Gordon GB, Wakabayashi N, Saunders B, Shen Y, Fujimura T et al: The effect of celecoxib, a cyclooxygenase-2 inhibitor, in familial adenomatous polyposis. *N Engl J Med* 2000, 342(26):1946-1952.

426. Matsushashi N, Nakajima A, Shinohara K, Oka T, Yazaki Y: Rectal cancer after sulindac therapy for a sporadic adenomatous colonic polyp. *Am J Gastroenterol* 1998, 93(11):2261-2266.
427. Giardiello FM, Hamilton SR, Krush AJ, Piantadosi S, Hylind LM, Celano P, Booker SV, Robinson CR, Offerhaus GJ: Treatment of colonic and rectal adenomas with sulindac in familial adenomatous polyposis. *N Engl J Med* 1993, 328(18):1313-1316.
428. Rigau J, Pique JM, Rubio E, Planas R, Tarrech JM, Bordas JM: Effects of long-term sulindac therapy on colonic polyposis. *Ann Intern Med* 1991, 115(12):952-954.
429. Hu PJ, Yu J, Zeng ZR, Leung WK, Lin HL, Tang BD, Bai AH, Sung JJ: Chemoprevention of gastric cancer by celecoxib in rats. *Gut* 2004, 53(2):195-200.
430. Sawaoka H, Kawano S, Tsuji S, Tsujii M, Gunawan ES, Takei Y, Nagano K, Hori M: Cyclooxygenase-2 inhibitors suppress the growth of gastric cancer xenografts via induction of apoptosis in nude mice. *Am J Physiol* 1998, 274(6 Pt 1):G1061-1067.
431. Beazer-Barclay Y, Levy DB, Moser AR, Dove WF, Hamilton SR, Vogelstein B, Kinzler KW: Sulindac suppresses tumorigenesis in the Min mouse. *Carcinogenesis* 1996, 17(8):1757-1760.
432. Tanaka T, Kojima T, Yoshimi N, Sugie S, Mori H: Inhibitory effect of the non-steroidal anti-inflammatory drug, indomethacin on the naturally occurring carcinogen, 1-hydroxyanthraquinone in male ACI/N rats. *Carcinogenesis* 1991, 12(10):1949-1952.
433. Gupta RA, Dubois RN: Colorectal cancer prevention and treatment by inhibition of cyclooxygenase-2. *Nat Rev Cancer* 2001, 1(1):11-21.
434. Chan AT, Ogino S, Fuchs CS: Aspirin use and survival after diagnosis of colorectal cancer. *JAMA* 2009, 302(6):649-658.
435. Chan TA: Nonsteroidal anti-inflammatory drugs, apoptosis, and colon-cancer chemoprevention. *Lancet Oncol* 2002, 3(3):166-174.
436. Chan TA, Morin PJ, Vogelstein B, Kinzler KW: Mechanisms underlying nonsteroidal antiinflammatory drug-mediated apoptosis. *Proc Natl Acad Sci U S A* 1998, 95(2):681-686.
437. Jana NR: NSAIDs and apoptosis. *Cell Mol Life Sci* 2008, 65(9):1295-1301.

438. Silverstein FE, Faich G, Goldstein JL, Simon LS, Pincus T, Whelton A, Makuch R, Eisen G, Agrawal NM, Stenson WF et al: Gastrointestinal toxicity with celecoxib vs nonsteroidal anti-inflammatory drugs for osteoarthritis and rheumatoid arthritis: the CLASS study: A randomized controlled trial. Celecoxib Long-term Arthritis Safety Study. *JAMA* 2000, 284(10):1247-1255.
439. Hinz B, Renner B, Brune K: Drug insight: cyclo-oxygenase-2 inhibitors--a critical appraisal. *Nat Clin Pract Rheumatol* 2007, 3(10):552-560; quiz 551 p following 589.
440. Scartozzi M, Galizia E, Freddari F, Berardi R, Cellerino R, Cascinu S: Molecular biology of sporadic gastric cancer: prognostic indicators and novel therapeutic approaches. *Cancer Treat Rev* 2004, 30(5):451-459.
441. Lim HY, Joo HJ, Choi JH, Yi JW, Yang MS, Cho DY, Kim HS, Nam DK, Lee KB, Kim HC: Increased expression of cyclooxygenase-2 protein in human gastric carcinoma. *Clin Cancer Res* 2000, 6(2):519-525.
442. Soydan AS, Gaffen JD, Weech PK, Tremblay NM, Kargman S, O'Neill G, Bennett A, Tavares IA: Cytosolic phospholipase A2, cyclo-oxygenases and arachidonate in human stomach tumours. *Eur J Cancer* 1997, 33(9):1508-1512.
443. Tsujii M, DuBois RN: Alterations in cellular adhesion and apoptosis in epithelial cells overexpressing prostaglandin endoperoxide synthase 2. *Cell* 1995, 83(3):493-501.
444. Scorrano L, Penzo D, Petronilli V, Pagano F, Bernardi P: Arachidonic acid causes cell death through the mitochondrial permeability transition. Implications for tumor necrosis factor-alpha apoptotic signaling. *J Biol Chem* 2001, 276(15):12035-12040.
445. Cao Y, Pearman AT, Zimmerman GA, McIntyre TM, Prescott SM: Intracellular unesterified arachidonic acid signals apoptosis. *Proc Natl Acad Sci U S A* 2000, 97(21):11280-11285.
446. Hannun YA: Functions of ceramide in coordinating cellular responses to stress. *Science* 1996, 274(5294):1855-1859.
447. Uefuji K, Ichikura T, Mochizuki H: Cyclooxygenase-2 expression is related to prostaglandin biosynthesis and angiogenesis in human gastric cancer. *Clin Cancer Res* 2000, 6(1):135-138.
448. Hanif R, Pittas A, Feng Y, Koutsos MI, Qiao L, Staiano-Coico L, Shiff SI, Rigas B: Effects of nonsteroidal anti-inflammatory drugs on proliferation and on induction of apoptosis in colon cancer cells by a prostaglandin-independent pathway. *Biochem Pharmacol* 1996, 52(2):237-245.

449. Soh JW, Weinstein IB: Role of COX-independent targets of NSAIDs and related compounds in cancer prevention and treatment. *Prog Exp Tumor Res* 2003, 37:261-285.
450. Zhang X, Morham SG, Langenbach R, Young DA: Malignant transformation and antineoplastic actions of nonsteroidal antiinflammatory drugs (NSAIDs) on cyclooxygenase-null embryo fibroblasts. *J Exp Med* 1999, 190(4):451-459.
451. O'Neill EA: A new target for aspirin. *Nature* 1998, 396(6706):15, 17.
452. Wong BC, Jiang X, Fan XM, Lin MC, Jiang SH, Lam SK, Kung HF: Suppression of RelA/p65 nuclear translocation independent of I κ B-alpha degradation by cyclooxygenase-2 inhibitor in gastric cancer. *Oncogene* 2003, 22(8):1189-1197.
453. Yin MJ, Yamamoto Y, Gaynor RB: The anti-inflammatory agents aspirin and salicylate inhibit the activity of I κ B kinase-beta. *Nature* 1998, 396(6706):77-80.
454. Kopp E, Ghosh S: Inhibition of NF-kappa B by sodium salicylate and aspirin. *Science* 1994, 265(5174):956-959.
455. Gu Q, Wang JD, Xia HH, Lin MC, He H, Zou B, Tu SP, Yang Y, Liu XG, Lam SK et al: Activation of the caspase-8/Bid and Bax pathways in aspirin-induced apoptosis in gastric cancer. *Carcinogenesis* 2005, 26(3):541-546.
456. Ho CC, Yang XW, Lee TL, Liao PH, Yang SH, Tsai CH, Chou MY: Activation of p53 signalling in acetylsalicylic acid-induced apoptosis in OC2 human oral cancer cells. *Eur J Clin Invest* 2003, 33(10):875-882.
457. Zhou XM, Wong BC, Fan XM, Zhang HB, Lin MC, Kung HF, Fan DM, Lam SK: Non-steroidal anti-inflammatory drugs induce apoptosis in gastric cancer cells through up-regulation of bax and bak. *Carcinogenesis* 2001, 22(9):1393-1397.
458. Redlak MJ, Power JJ, Miller TA: Role of mitochondria in aspirin-induced apoptosis in human gastric epithelial cells. *Am J Physiol Gastrointest Liver Physiol* 2005, 289(4):G731-738.
459. Zimmermann KC, Waterhouse NJ, Goldstein JC, Schuler M, Green DR: Aspirin induces apoptosis through release of cytochrome c from mitochondria. *Neoplasia* 2000, 2(6):505-513.
460. Pique M, Barragan M, Dalmau M, Bellosillo B, Pons G, Gil J: Aspirin induces apoptosis through mitochondrial cytochrome c release. *FEBS Lett* 2000, 480(2-3):193-196.

461. Bellosillo B, Pique M, Barragan M, Castano E, Villamor N, Colomer D, Montserrat E, Pons G, Gil J: Aspirin and salicylate induce apoptosis and activation of caspases in B-cell chronic lymphocytic leukemia cells. *Blood* 1998, 92(4):1406-1414.
462. Dikshit P, Chatterjee M, Goswami A, Mishra A, Jana NR: Aspirin induces apoptosis through the inhibition of proteasome function. *J Biol Chem* 2006, 281(39):29228-29235.
463. Huang YC, Chuang LY, Hung WC: Mechanisms underlying nonsteroidal anti-inflammatory drug-induced p27(Kip1) expression. *Mol Pharmacol* 2002, 62(6):1515-1521.
464. Luciani MG, Campregher C, Gasche C: Aspirin blocks proliferation in colon cells by inducing a G1 arrest and apoptosis through activation of the checkpoint kinase ATM. *Carcinogenesis* 2007, 28(10):2207-2217.
465. Bock JM, Menon SG, Goswami PC, Sinclair LL, Bedford NS, Domann FE, Trask DK: Relative non-steroidal anti-inflammatory drug (NSAID) antiproliferative activity is mediated through p21-induced G1 arrest and E2F inhibition. *Mol Carcinog* 2007, 46(10):857-864.
466. Piazza GA, Rahm AK, Finn TS, Fryer BH, Li H, Stoumen AL, Pamukcu R, Ahnen DJ: Apoptosis primarily accounts for the growth-inhibitory properties of sulindac metabolites and involves a mechanism that is independent of cyclooxygenase inhibition, cell cycle arrest, and p53 induction. *Cancer Res* 1997, 57(12):2452-2459.
467. Adachi M, Sakamoto H, Kawamura R, Wang W, Imai K, Shinomura Y: Nonsteroidal anti-inflammatory drugs and oxidative stress in cancer cells. *Histol Histopathol* 2007, 22(4):437-442.
468. Gao J, Liu X, Rigas B: Nitric oxide-donating aspirin induces apoptosis in human colon cancer cells through induction of oxidative stress. *Proc Natl Acad Sci U S A* 2005, 102(47):17207-17212.
469. Tsutsumi S, Gotoh T, Tomisato W, Mima S, Hoshino T, Hwang HJ, Takenaka H, Tsuchiya T, Mori M, Mizushima T: Endoplasmic reticulum stress response is involved in nonsteroidal anti-inflammatory drug-induced apoptosis. *Cell Death Differ* 2004, 11(9):1009-1016.
470. Wong BC, Jiang XH, Lin MC, Tu SP, Cui JT, Jiang SH, Wong WM, Yuen MF, Lam SK, Kung HF: Cyclooxygenase-2 inhibitor (SC-236) suppresses activator protein-1 through c-Jun NH2-terminal kinase. *Gastroenterology* 2004, 126(1):136-147.

471. Schwenger P, Bellosta P, Vietor I, Basilico C, Skolnik EY, Vilcek J: Sodium salicylate induces apoptosis via p38 mitogen-activated protein kinase but inhibits tumor necrosis factor-induced c-Jun N-terminal kinase/stress-activated protein kinase activation. *Proc Natl Acad Sci U S A* 1997, 94(7):2869-2873.
472. Shureiqi I, Chen D, Lee JJ, Yang P, Newman RA, Brenner DE, Lotan R, Fischer SM, Lippman SM: 15-LOX-1: a novel molecular target of nonsteroidal anti-inflammatory drug-induced apoptosis in colorectal cancer cells. *J Natl Cancer Inst* 2000, 92(14):1136-1142.
473. Pasricha PJ, Bedi A, O'Connor K, Rashid A, Akhtar AJ, Zahurak ML, Piantadosi S, Hamilton SR, Giardiello FM: The effects of sulindac on colorectal proliferation and apoptosis in familial adenomatous polyposis. *Gastroenterology* 1995, 109(3):994-998.
474. Shiff SJ, Qiao L, Tsai LL, Rigas B: Sulindac sulfide, an aspirin-like compound, inhibits proliferation, causes cell cycle quiescence, and induces apoptosis in HT-29 colon adenocarcinoma cells. *J Clin Invest* 1995, 96(1):491-503.
475. Shureiqi I, Jiang W, Zuo X, Wu Y, Stimmel JB, Leesnitzer LM, Morris JS, Fan HZ, Fischer SM, Lippman SM: The 15-lipoxygenase-1 product 13-S-hydroxyoctadecadienoic acid down-regulates PPAR-delta to induce apoptosis in colorectal cancer cells. *Proc Natl Acad Sci U S A* 2003, 100(17):9968-9973.
476. Kliewer SA, Sundseth SS, Jones SA, Brown PJ, Wisely GB, Koble CS, Devchand P, Wahli W, Willson TM, Lenhard JM et al: Fatty acids and eicosanoids regulate gene expression through direct interactions with peroxisome proliferator-activated receptors alpha and gamma. *Proc Natl Acad Sci U S A* 1997, 94(9):4318-4323.
477. Reid G, Wielinga P, Zelcer N, van der Heijden I, Kuil A, de Haas M, Wijnholds J, Borst P: The human multidrug resistance protein MRP4 functions as a prostaglandin efflux transporter and is inhibited by nonsteroidal antiinflammatory drugs. *Proc Natl Acad Sci U S A* 2003, 100(16):9244-9249.
478. Takada Y, Bhardwaj A, Potdar P, Aggarwal BB: Nonsteroidal anti-inflammatory agents differ in their ability to suppress NF-kappaB activation, inhibition of expression of cyclooxygenase-2 and cyclin D1, and abrogation of tumor cell proliferation. *Oncogene* 2004, 23(57):9247-9258.
479. Andrews J, Djakiew D, Krygier S, Andrews P: Superior effectiveness of ibuprofen compared with other NSAIDs for reducing the survival of human prostate cancer cells. *Cancer Chemother Pharmacol* 2002, 50(4):277-284.
480. Garg A, Aggarwal BB: Nuclear transcription factor-kappaB as a target for cancer drug development. *Leukemia* 2002, 16(6):1053-1068.

481. Mattson MP, Camandola S: NF-kappaB in neuronal plasticity and neurodegenerative disorders. *J Clin Invest* 2001, 107(3):247-254.
482. Baeuerle PA, Baltimore D: NF-kappa B: ten years after. *Cell* 1996, 87(1):13-20.
483. McCarty MF, Block KI: Preadministration of high-dose salicylates, suppressors of NF-kappaB activation, may increase the chemosensitivity of many cancers: an example of proapoptotic signal modulation therapy. *Integr Cancer Ther* 2006, 5(3):252-268.
484. Kim KM, Song JJ, An JY, Kwon YT, Lee YJ: Pretreatment of acetylsalicylic acid promotes tumor necrosis factor-related apoptosis-inducing ligand-induced apoptosis by down-regulating BCL-2 gene expression. *J Biol Chem* 2005, 280(49):41047-41056.
485. Stark LA, Reid K, Sansom OJ, Din FV, Guichard S, Mayer I, Jodrell DI, Clarke AR, Dunlop MG: Aspirin activates the NF-kappaB signalling pathway and induces apoptosis in intestinal neoplasia in two in vivo models of human colorectal cancer. *Carcinogenesis* 2007, 28(5):968-976.
486. Din FV, Stark LA, Dunlop MG: Aspirin-induced nuclear translocation of NFkappaB and apoptosis in colorectal cancer is independent of p53 status and DNA mismatch repair proficiency. *Br J Cancer* 2005, 92(6):1137-1143.
487. Reed JC: Cytochrome c: can't live with it--can't live without it. *Cell* 1997, 91(5):559-562.
488. Liu XH, Yao S, Kirschenbaum A, Levine AC: NS398, a selective cyclooxygenase-2 inhibitor, induces apoptosis and down-regulates bcl-2 expression in LNCaP cells. *Cancer Res* 1998, 58(19):4245-4249.
489. Zhang L, Yu J, Park BH, Kinzler KW, Vogelstein B: Role of BAX in the apoptotic response to anticancer agents. *Science* 2000, 290(5493):989-992.
490. Zhu GH, Wong BC, Slosberg ED, Eggo MC, Ching CK, Yuen ST, Lai KC, Soh JW, Weinstein IB, Lam SK: Overexpression of protein kinase C-beta1 isoenzyme suppresses indomethacin-induced apoptosis in gastric epithelial cells. *Gastroenterology* 2000, 118(3):507-514.
491. Glickman MH, Ciechanover A: The ubiquitin-proteasome proteolytic pathway: destruction for the sake of construction. *Physiol Rev* 2002, 82(2):373-428.
492. Orłowski RZ: The role of the ubiquitin-proteasome pathway in apoptosis. *Cell Death Differ* 1999, 6(4):303-313.
493. Jana NR, Dikshit P, Goswami A, Nukina N: Inhibition of proteasomal function by curcumin induces apoptosis through mitochondrial pathway. *J Biol Chem* 2004, 279(12):11680-11685.

494. Drexler HC, Risau W, Konecny MA: Inhibition of proteasome function induces programmed cell death in proliferating endothelial cells. *FASEB J* 2000, 14(1):65-77.
495. Lopes UG, Erhardt P, Yao R, Cooper GM: p53-dependent induction of apoptosis by proteasome inhibitors. *J Biol Chem* 1997, 272(20):12893-12896.
496. Bush KT, Goldberg AL, Nigam SK: Proteasome inhibition leads to a heat-shock response, induction of endoplasmic reticulum chaperones, and thermotolerance. *J Biol Chem* 1997, 272(14):9086-9092.
497. Kaufman RJ: Orchestrating the unfolded protein response in health and disease. *J Clin Invest* 2002, 110(10):1389-1398.
498. Pillinger MH, Capodici C, Rosenthal P, Kheterpal N, Hanft S, Philips MR, Weissmann G: Modes of action of aspirin-like drugs: salicylates inhibit erk activation and integrin-dependent neutrophil adhesion. *Proc Natl Acad Sci U S A* 1998, 95(24):14540-14545.
499. Rigas B: The use of nitric oxide-donating nonsteroidal anti-inflammatory drugs in the chemoprevention of colorectal neoplasia. *Curr Opin Gastroenterol* 2007, 23(1):55-59.
500. Tortora G, Caputo R, Damiano V, Melisi D, Bianco R, Fontanini G, Veneziani BM, De Placido S, Bianco AR, Ciardiello F: Combination of a selective cyclooxygenase-2 inhibitor with epidermal growth factor receptor tyrosine kinase inhibitor ZD1839 and protein kinase A antisense causes cooperative antitumor and antiangiogenic effect. *Clin Cancer Res* 2003, 9(4):1566-1572.
501. Wagenaar-Miller RA, Hanley G, Shattuck-Brandt R, DuBois RN, Bell RL, Matrisian LM, Morgan DW: Cooperative effects of matrix metalloproteinase and cyclooxygenase-2 inhibition on intestinal adenoma reduction. *Br J Cancer* 2003, 88(9):1445-1452.
502. Mann M, Sheng H, Shao J, Williams CS, Pisacane PI, Sliwkowski MX, DuBois RN: Targeting cyclooxygenase 2 and HER-2/neu pathways inhibits colorectal carcinoma growth. *Gastroenterology* 2001, 120(7):1713-1719.
503. Kune GA, Kune S, Watson LF: Colorectal cancer risk, chronic illnesses, operations, and medications: case control results from the Melbourne Colorectal Cancer Study. *Cancer Res* 1988, 48(15):4399-4404.
504. Bosetti C, Gallus S, La Vecchia C: Aspirin and cancer risk: an updated quantitative review to 2005. *Cancer Causes Control* 2006, 17(7):871-888.

505. Chan AT, Giovannucci EL, Meyerhardt JA, Schernhammer ES, Wu K, Fuchs CS: Aspirin dose and duration of use and risk of colorectal cancer in men. *Gastroenterology* 2008, 134(1):21-28.
506. Chan AT, Giovannucci EL, Meyerhardt JA, Schernhammer ES, Curhan GC, Fuchs CS: Long-term use of aspirin and nonsteroidal anti-inflammatory drugs and risk of colorectal cancer. *JAMA* 2005, 294(8):914-923.
507. Holmes MD, Chen WY, Li L, Hertzmark E, Spiegelman D, Hankinson SE: Aspirin intake and survival after breast cancer. *J Clin Oncol* 2010, 28(9):1467-1472.
508. Lebeau B, Chastang C, Muir JF, Vincent J, Massin F, Fabre C: No effect of an antiaggregant treatment with aspirin in small cell lung cancer treated with CCAVP16 chemotherapy. Results from a randomized clinical trial of 303 patients. The "Petites Cellules" Group. *Cancer* 1993, 71(5):1741-1745.
509. Creagan ET, Twito DI, Johansson SL, Schaid DJ, Johnson PS, Flaum MA, Buroker TR, Geeraerts LH, Veeder MH, Gesme DH, Jr. et al: A randomized prospective assessment of recombinant leukocyte A human interferon with or without aspirin in advanced renal adenocarcinoma. *J Clin Oncol* 1991, 9(12):2104-2109.
510. Lipton A, Scialla S, Harvey H, Dixon R, Gordon R, Hamilton R, Ramsey H, Weltz M, Heckard R, White D: Adjuvant antiplatelet therapy with aspirin in colo-rectal cancer. *J Med* 1982, 13(5-6):419-429.
511. Krymchantowski AV, Adriano M, Fernandes D: Tolfenamic acid decreases migraine recurrence when used with sumatriptan. *Cephalalgia* 1999, 19(3):186-187.
512. Eskerod O: Gastrointestinal tolerance studies on tolfenamic acid in humans and animals. *Pharmacol Toxicol* 1994, 75 Suppl 2:44-48.
513. Isomaki H, Martio J, Kaarela K, Kajander A, Koota K, Lehtinen K, Luukkainen R, Martio T, Nissila M, Nuotio P et al: Comparison of the analgesic effect of ten nonsteroidal anti-inflammatory drugs. *Br J Rheumatol* 1984, 23(1):61-65.
514. Keinanen S, Simila S, Kouvalainen K: Oral antipyretic therapy: evaluation of the N-aryl-anthranilic acid derivatives mefenamic acid, tolfenamic acid and flufenamic acid. *Eur J Clin Pharmacol* 1978, 13(5):331-344.
515. Kim JH, Jung JY, Shim JH, Kim J, Choi KH, Shin JA, Choi ES, Lee SO, Chintharlapalli S, Kwon KH et al: Apoptotic Effect of Tolfenamic Acid in KB Human Oral Cancer Cells: Possible Involvement of the p38 MAPK Pathway. *J Clin Biochem Nutr* 2010, 47(1):74-80.

516. Basha R, Baker CH, Sankpal UT, Ahmad S, Safe S, Abbruzzese JL, Abdelrahim M: Therapeutic applications of NSAIDS in cancer: special emphasis on tolfenamic acid. *Front Biosci (Schol Ed)* 2011, 3:797-805.
517. Gilpin RK, Zhou W: Infrared studies of the polymorphic states of the fenamates. *J Pharm Biomed Anal* 2005, 37(3):509-515.
518. Abdelrahim M, Baker CH, Abbruzzese JL, Safe S: Tolfenamic acid and pancreatic cancer growth, angiogenesis, and Sp protein degradation. *J Natl Cancer Inst* 2006, 98(12):855-868.
519. Liu X, Abdelrahim M, Abudayyeh A, Lei P, Safe S: The nonsteroidal anti-inflammatory drug tolfenamic acid inhibits BT474 and SKBR3 breast cancer cell and tumor growth by repressing erbB2 expression. *Mol Cancer Ther* 2009, 8(5):1207-1217.
520. Papineni S, Chintharlapalli S, Abdelrahim M, Lee SO, Burghardt R, Abudayyeh A, Baker C, Herrera L, Safe S: Tolfenamic acid inhibits esophageal cancer through repression of specificity proteins and c-Met. *Carcinogenesis* 2009, 30(7):1193-1201.
521. Colon J, Basha MR, Madero-Visbal R, Konduri S, Baker CH, Herrera LJ, Safe S, Sheikh-Hamad D, Abudayyeh A, Alvarado B et al: Tolfenamic acid decreases c-Met expression through Sp proteins degradation and inhibits lung cancer cells growth and tumor formation in orthotopic mice. *Invest New Drugs* 2011, 29(1):41-51.
522. Konduri S, Colon J, Baker CH, Safe S, Abbruzzese JL, Abudayyeh A, Basha MR, Abdelrahim M: Tolfenamic acid enhances pancreatic cancer cell and tumor response to radiation therapy by inhibiting survivin protein expression. *Mol Cancer Ther* 2009, 8(3):533-542.
523. Lee SH, Bahn JH, Choi CK, Whitlock NC, English AE, Safe S, Baek SJ: ESE-1/EGR-1 pathway plays a role in tolfenamic acid-induced apoptosis in colorectal cancer cells. *Mol Cancer Ther* 2008, 7(12):3739-3750.
524. Basha R, Ingersoll SB, Sankpal UT, Ahmad S, Baker CH, Edwards JR, Holloway RW, Kaja S, Abdelrahim M: Tolfenamic acid inhibits ovarian cancer cell growth and decreases the expression of c-Met and survivin through suppressing specificity protein transcription factors. *Gynecol Oncol* 2011, 122(1):163-170.
525. Kakizawa H, Matsui F, Tokita Y, Hirano K, Ida M, Nakanishi K, Watanabe M, Sato Y, Okumura A, Kojima S et al: Neuroprotective effect of nipradilol, an NO donor, on hypoxic-ischemic brain injury of neonatal rats. *Early Hum Dev* 2007, 83(8):535-540.

526. Gresele P, Momi S: Pharmacologic profile and therapeutic potential of NCX 4016, a nitric oxide-releasing aspirin, for cardiovascular disorders. *Cardiovasc Drug Rev* 2006, 24(2):148-168.
527. Thatcher GR, Bennett BM, Reynolds JN: NO chimeras as therapeutic agents in Alzheimer's disease. *Curr Alzheimer Res* 2006, 3(3):237-245.
528. Kimura I: Medical benefits of using natural compounds and their derivatives having multiple pharmacological actions. *Yakugaku Zasshi* 2006, 126(3):133-143.
529. Zhang ZG, Zhang YH, Ji H, Qiu SG, Feng XC: [Design, synthesis and antiasthmatic activities of NO-donating seratrodist derivatives]. *Yao Xue Xue Bao* 2004, 39(9):705-710.
530. Kaza CS, Kashfi K, Rigas B: Colon cancer prevention with NO-releasing NSAIDs. *Prostaglandins Other Lipid Mediat* 2002, 67(2):107-120.
531. del Soldato P, Sorrentino R, Pinto A: NO-aspirins: a class of new anti-inflammatory and antithrombotic agents. *Trends Pharmacol Sci* 1999, 20(8):319-323.
532. Rigas B: Novel agents for cancer prevention based on nitric oxide. *Biochem Soc Trans* 2007, 35(Pt 5):1364-1368.
533. Kitagawa H, Takeda F, Kohei H: Effect of endothelium-derived relaxing factor on the gastric lesion induced by HCl in rats. *J Pharmacol Exp Ther* 1990, 253(3):1133-1137.
534. MacNaughton WK, Cirino G, Wallace JL: Endothelium-derived relaxing factor (nitric oxide) has protective actions in the stomach. *Life Sci* 1989, 45(20):1869-1876.
535. Ellis JL, Augustyniak ME, Cochran ED, Earl RA, Garvey DS, Gordon LJ, Janero DR, Khanapure SP, Letts LG, Melim TL et al: NMI-1182, a gastro-protective cyclo-oxygenase-inhibiting nitric oxide donor. *Inflammopharmacology* 2005, 12(5-6):521-534.
536. Fiorucci S, Santucci L, Gresele P, Faccino RM, Del Soldato P, Morelli A: Gastrointestinal safety of NO-aspirin (NCX-4016) in healthy human volunteers: a proof of concept endoscopic study. *Gastroenterology* 2003, 124(3):600-607.
537. Tesei A, Rosetti M, Ulivi P, Fabbri F, Medri L, Vannini I, Bolla M, Amadori D, Zoli W: Study of molecular mechanisms of pro-apoptotic activity of NCX 4040, a novel nitric oxide-releasing aspirin, in colon cancer cell lines. *J Transl Med* 2007, 5:52.

538. Rao CV, Reddy BS, Steele VE, Wang CX, Liu X, Ouyang N, Patlolla JM, Simi B, Kopelovich L, Rigas B: Nitric oxide-releasing aspirin and indomethacin are potent inhibitors against colon cancer in azoxymethane-treated rats: effects on molecular targets. *Mol Cancer Ther* 2006, 5(6):1530-1538.
539. Rosetti M, Tesei A, Ulivi P, Fabbri F, Vannini I, Briigliadori G, Amadori D, Bolla M, Zoli W: Molecular characterization of cytotoxic and resistance mechanisms induced by NCX 4040, a novel NO-NSAID, in pancreatic cancer cell lines. *Apoptosis* 2006, 11(8):1321-1330.
540. Leonetti C, Scarsella M, Zupi G, Zoli W, Amadori D, Medri L, Fabbri F, Rosetti M, Ulivi P, Ceconetto L et al: Efficacy of a nitric oxide-releasing nonsteroidal anti-inflammatory drug and cytotoxic drugs in human colon cancer cell lines in vitro and xenografts. *Mol Cancer Ther* 2006, 5(4):919-926.
541. Fabbri F, Briigliadori G, Ulivi P, Tesei A, Vannini I, Rosetti M, Bravaccini S, Amadori D, Bolla M, Zoli W: Pro-apoptotic effect of a nitric oxide-donating NSAID, NCX 4040, on bladder carcinoma cells. *Apoptosis* 2005, 10(5):1095-1103.
542. Tesei A, Ulivi P, Fabbri F, Rosetti M, Leonetti C, Scarsella M, Zupi G, Amadori D, Bolla M, Zoli W: In vitro and in vivo evaluation of NCX 4040 cytotoxic activity in human colon cancer cell lines. *J Transl Med* 2005, 3(1):7.
543. Huguenin S, Vacherot F, Fleury-Feith J, Riffaud JP, Chopin DK, Bolla M, Jaurand MC: Evaluation of the antitumoral potential of different nitric oxide-donating non-steroidal anti-inflammatory drugs (NO-NSAIDs) on human urological tumor cell lines. *Cancer Lett* 2005, 218(2):163-170.
544. Royle JS, Ross JA, Ansell I, Bollina P, Tulloch DN, Habib FK: Nitric oxide donating nonsteroidal anti-inflammatory drugs induce apoptosis in human prostate cancer cell systems and human prostatic stroma via caspase-3. *J Urol* 2004, 172(1):338-344.
545. Huguenin S, Vacherot F, Kheuang L, Fleury-Feith J, Jaurand MC, Bolla M, Riffaud JP, Chopin DK: Antiproliferative effect of nitrosulindac (NCX 1102), a new nitric oxide-donating non-steroidal anti-inflammatory drug, on human bladder carcinoma cell lines. *Mol Cancer Ther* 2004, 3(3):291-298.
546. Tesei A, Ricotti L, Ulivi P, Medri L, Amadori D, Zoli W: NCX 4016, a nitric oxide-releasing aspirin derivative, exhibits a significant antiproliferative effect and alters cell cycle progression in human colon adenocarcinoma cell lines. *Int J Oncol* 2003, 22(6):1297-1302.
547. Kashfi K, Ryan Y, Qiao LL, Williams JL, Chen J, Del Soldato P, Traganos F, Rigas B: Nitric oxide-donating nonsteroidal anti-inflammatory drugs inhibit the growth of various cultured human cancer cells: evidence of a tissue type-independent effect. *J Pharmacol Exp Ther* 2002, 303(3):1273-1282.

548. Williams JL, Borgo S, Hasan I, Castillo E, Traganos F, Rigas B: Nitric oxide-releasing nonsteroidal anti-inflammatory drugs (NSAIDs) alter the kinetics of human colon cancer cell lines more effectively than traditional NSAIDs: implications for colon cancer chemoprevention. *Cancer Res* 2001, 61(8):3285-3289.
549. Wink DA, Cook JA, Kim SY, Vodovotz Y, Pacelli R, Krishna MC, Russo A, Mitchell JB, Jourd'heuil D, Miles AM et al: Superoxide modulates the oxidation and nitrosation of thiols by nitric oxide-derived reactive intermediates. Chemical aspects involved in the balance between oxidative and nitrosative stress. *J Biol Chem* 1997, 272(17):11147-11151.
550. Carini M, Aldini G, Orioli M, Piccoli A, Rossoni G, Maffei Facino R: Nitric oxide release and distribution following oral and intraperitoneal administration of nitroaspirin (NCX 4016) in the rat. *Life Sci* 2004, 74(26):3291-3305.
551. Carini M, Aldini G, Orioli M, Piccoli A, Tocchetti P, Facino RM: Chemiluminescence and LC-MS/MS analyses for the study of nitric oxide release and distribution following oral administration of nitroaspirin (NCX 4016) in healthy volunteers. *J Pharm Biomed Anal* 2004, 35(2):277-287.
552. Yeh RK, Chen J, Williams JL, Baluch M, Hundley TR, Rosenbaum RE, Kalala S, Traganos F, Benardini F, del Soldato P et al: NO-donating nonsteroidal antiinflammatory drugs (NSAIDs) inhibit colon cancer cell growth more potently than traditional NSAIDs: a general pharmacological property? *Biochem Pharmacol* 2004, 67(12):2197-2205.
553. Williams JL, Kashfi K, Ouyang N, del Soldato P, Kopelovich L, Rigas B: NO-donating aspirin inhibits intestinal carcinogenesis in Min (APC(Min/+)) mice. *Biochem Biophys Res Commun* 2004, 313(3):784-788.
554. Zhou H, Huang L, Sun Y, Rigas B: Nitric oxide-donating aspirin inhibits the growth of pancreatic cancer cells through redox-dependent signaling. *Cancer Lett* 2009, 273(2):292-299.
555. Selvendiran K, Bratasz A, Tong L, Ignarro LJ, Kuppusamy P: NCX-4016, a nitro-derivative of aspirin, inhibits EGFR and STAT3 signaling and modulates Bcl-2 proteins in cisplatin-resistant human ovarian cancer cells and xenografts. *Cell Cycle* 2008, 7(1):81-88.
556. Ouyang N, Williams JL, Tsioulis GJ, Gao J, Iatropoulos MJ, Kopelovich L, Kashfi K, Rigas B: Nitric oxide-donating aspirin prevents pancreatic cancer in a hamster tumor model. *Cancer Res* 2006, 66(8):4503-4511.
557. Rigas B, Kashfi K: Nitric-oxide-donating NSAIDs as agents for cancer prevention. *Trends Mol Med* 2004, 10(7):324-330.

558. Spiegel A, Hundley TR, Chen J, Gao J, Ouyang N, Liu X, Go MF, Tsioulis GJ, Kashfi K, Rigas B: NO-donating aspirin inhibits both the expression and catalytic activity of inducible nitric oxide synthase in HT-29 human colon cancer cells. *Biochem Pharmacol* 2005, 70(7):993-1000.
559. Williams JL, Ji P, Ouyang N, Liu X, Rigas B: NO-donating aspirin inhibits the activation of NF-kappaB in human cancer cell lines and Min mice. *Carcinogenesis* 2008, 29(2):390-397.
560. Williams JL, Nath N, Chen J, Hundley TR, Gao J, Kopelovich L, Kashfi K, Rigas B: Growth inhibition of human colon cancer cells by nitric oxide (NO)-donating aspirin is associated with cyclooxygenase-2 induction and beta-catenin/T-cell factor signaling, nuclear factor-kappaB, and NO synthase 2 inhibition: implications for chemoprevention. *Cancer Res* 2003, 63(22):7613-7618.
561. Gao J, Kashfi K, Liu X, Rigas B: NO-donating aspirin induces phase II enzymes in vitro and in vivo. *Carcinogenesis* 2006, 27(4):803-810.
562. McIlhatton MA, Tyler J, Burkholder S, Ruschoff J, Rigas B, Kopelovich L, Fishel R: Nitric oxide-donating aspirin derivatives suppress microsatellite instability in mismatch repair-deficient and hereditary nonpolyposis colorectal cancer cells. *Cancer Res* 2007, 67(22):10966-10975.
563. Hagos GK, Abdul-Hay SO, Sohn J, Edirisinghe PD, Chandrasena RE, Wang Z, Li Q, Thatcher GR: Anti-inflammatory, antiproliferative, and cytoprotective activity of NO chimera nitrates of use in cancer chemoprevention. *Mol Pharmacol* 2008, 74(5):1381-1391.
564. Wang D, Dubois RN: Prostaglandins and cancer. *Gut* 2006, 55(1):115-122.
565. Halaschek-Wiener J, Wacheck V, Schlagbauer-Wadl H, Wolff K, Kloog Y, Jansen B: A novel Ras antagonist regulates both oncogenic Ras and the tumor suppressor p53 in colon cancer cells. *Mol Med* 2000, 6(8):693-704.
566. Druesne N, Pagniez A, Mayeur C, Thomas M, Cherbuy C, Duee PH, Martel P, Chaumontet C: Diallyl disulfide (DADS) increases histone acetylation and p21(waf1/cip1) expression in human colon tumor cell lines. *Carcinogenesis* 2004, 25(7):1227-1236.
567. Knowles LM, Milner JA: Diallyl disulfide induces ERK phosphorylation and alters gene expression profiles in human colon tumor cells. *J Nutr* 2003, 133(9):2901-2906.
568. Harrison LE, Wang QM, Studzinski GP: Butyrate-induced G2/M block in Caco-2 colon cancer cells is associated with decreased p34cdc2 activity. *Proc Soc Exp Biol Med* 1999, 222(2):150-156.

569. Wargovich MJ, Chen CD, Jimenez A, Steele VE, Velasco M, Stephens LC, Price R, Gray K, Kelloff GJ: Aberrant crypts as a biomarker for colon cancer: evaluation of potential chemopreventive agents in the rat. *Cancer Epidemiol Biomarkers Prev* 1996, 5(5):355-360.
570. Hagos GK, Carroll RE, Kouznetsova T, Li Q, Toader V, Fernandez PA, Swanson SM, Thatcher GR: Colon cancer chemoprevention by a novel NO chimera that shows anti-inflammatory and antiproliferative activity in vitro and in vivo. *Mol Cancer Ther* 2007, 6(8):2230-2239.
571. Chung HT, Pae HO, Choi BM, Billiar TR, Kim YM: Nitric oxide as a bioregulator of apoptosis. *Biochem Biophys Res Commun* 2001, 282(5):1075-1079.
572. Pathi SS, Jutooru I, Chadalapaka G, Sreevalsan S, Anand S, Thatcher GR, Safe S: GT-094, a NO-NSAID, inhibits colon cancer cell growth by activation of a reactive oxygen species-microRNA-27a: ZBTB10-specificity protein pathway. *Mol Cancer Res* 2011, 9(2):195-202.
573. Szent-Gyorgyi A: Observations on the function of peroxidase systems and the chemistry of the adrenal cortex: Description of a new carbohydrate derivative. *Biochem J* 1928, 22(6):1387-1409.
574. Svirbely JL, Szent-Gyorgyi A: The chemical nature of vitamin C. *Biochem J* 1933, 27(1):279-285.
575. King CG, Waugh WA: The chemical nature of vitamin C. *Science* 1932, 75(1944):357-358.
576. Banhegyi G, Braun L, Csala M, Puskas F, Mandl J: Ascorbate metabolism and its regulation in animals. *Free Radic Biol Med* 1997, 23(5):793-803.
577. Verrax J, Calderon PB: The controversial place of vitamin C in cancer treatment. *Biochem Pharmacol* 2008, 76(12):1644-1652.
578. Chen Q, Espey MG, Krishna MC, Mitchell JB, Corpe CP, Buettner GR, Shacter E, Levine M: Pharmacologic ascorbic acid concentrations selectively kill cancer cells: action as a pro-drug to deliver hydrogen peroxide to tissues. *Proc Natl Acad Sci U S A* 2005, 102(38):13604-13609.
579. Riordan NH, Riordan HD, Meng X, Li Y, Jackson JA: Intravenous ascorbate as a tumor cytotoxic chemotherapeutic agent. *Med Hypotheses* 1995, 44(3):207-213.
580. De Laurenzi V, Melino G, Savini I, Annicchiarico-Petruzzelli M, Finazzi-Agro A, Avigliano L: Cell death by oxidative stress and ascorbic acid regeneration in human neuroectodermal cell lines. *Eur J Cancer* 1995, 31A(4):463-466.

581. Cameron E, Campbell A: The orthomolecular treatment of cancer. II. Clinical trial of high-dose ascorbic acid supplements in advanced human cancer. *Chem Biol Interact* 1974, 9(4):285-315.
582. Golde DW: Vitamin C in cancer. *Integr Cancer Ther* 2003, 2(2):158-159.
583. Cameron E, Pauling L, Leibovitz B: Ascorbic acid and cancer: a review. *Cancer Res* 1979, 39(3):663-681.
584. Cameron E, Pauling L: Supplemental ascorbate in the supportive treatment of cancer: reevaluation of prolongation of survival times in terminal human cancer. *Proc Natl Acad Sci U S A* 1978, 75(9):4538-4542.
585. Padayatty SJ, Levine M: Reevaluation of ascorbate in cancer treatment: emerging evidence, open minds and serendipity. *J Am Coll Nutr* 2000, 19(4):423-425.
586. Wittes RE: Vitamin C and cancer. *N Engl J Med* 1985, 312(3):178-179.
587. Moertel CG, Fleming TR, Creagan ET, Rubin J, O'Connell MJ, Ames MM: High-dose vitamin C versus placebo in the treatment of patients with advanced cancer who have had no prior chemotherapy. A randomized double-blind comparison. *N Engl J Med* 1985, 312(3):137-141.
588. Creagan ET, Moertel CG, O'Fallon JR, Schutt AJ, O'Connell MJ, Rubin J, Frytak S: Failure of high-dose vitamin C (ascorbic acid) therapy to benefit patients with advanced cancer. A controlled trial. *N Engl J Med* 1979, 301(13):687-690.
589. Cameron E, Rotman D: Ascorbic acid, cell proliferation, and cancer. *Lancet* 1972, 1(7749):542.
590. Mc CW: Cancer: a collagen disease, secondary to a nutritional deficiency. *Arch Pediatr* 1959, 76(4):166-171.
591. Mc CW: Cancer: the preconditioning factor in pathogenesis; a new etiologic approach. *Arch Pediatr* 1954, 71(10):313-322.
592. Cameron E, Pauling L: Ascorbic acid and the glycosaminoglycans. An orthomolecular approach to cancer and other diseases. *Oncology* 1973, 27(2):181-192.
593. Head KA: Ascorbic acid in the prevention and treatment of cancer. *Altern Med Rev* 1998, 3(3):174-186.
594. Lee WJ: The prospects of vitamin C in cancer therapy. *Immune Netw* 2009, 9(5):147-152.

595. Cameron E, Campbell A: Innovation vs. quality control: an 'unpublishable' clinical trial of supplemental ascorbate in incurable cancer. *Med Hypotheses* 1991, 36(3):185-189.
596. Ohno S, Ohno Y, Suzuki N, Soma G, Inoue M: High-dose vitamin C (ascorbic acid) therapy in the treatment of patients with advanced cancer. *Anticancer Res* 2009, 29(3):809-815.
597. Block KI, Mead MN: Vitamin C in alternative cancer treatment: historical background. *Integr Cancer Ther* 2003, 2(2):147-154.
598. Graumlich JF, Ludden TM, Conry-Cantilena C, Cantilena LR, Jr., Wang Y, Levine M: Pharmacokinetic model of ascorbic acid in healthy male volunteers during depletion and repletion. *Pharm Res* 1997, 14(9):1133-1139.
599. Omaye ST, Skala JH, Jacob RA: Plasma ascorbic acid in adult males: effects of depletion and supplementation. *Am J Clin Nutr* 1986, 44(2):257-264.
600. Padayatty SJ, Sun H, Wang Y, Riordan HD, Hewitt SM, Katz A, Wesley RA, Levine M: Vitamin C pharmacokinetics: implications for oral and intravenous use. *Ann Intern Med* 2004, 140(7):533-537.
601. Chen Q, Espey MG, Sun AY, Pooput C, Kirk KL, Krishna MC, Khosh DB, Drisko J, Levine M: Pharmacologic doses of ascorbate act as a prooxidant and decrease growth of aggressive tumor xenografts in mice. *Proc Natl Acad Sci U S A* 2008, 105(32):11105-11109.
602. Shamim U, Hanif S, Ullah MF, Azmi AS, Bhat SH, Hadi SM: Plant polyphenols mobilize nuclear copper in human peripheral lymphocytes leading to oxidatively generated DNA breakage: implications for an anticancer mechanism. *Free Radic Res* 2008, 42(8):764-772.
603. Halliwell B: Oxidative stress in cell culture: an under-appreciated problem? *FEBS Lett* 2003, 540(1-3):3-6.
604. Clement MV, Long LH, Ramalingam J, Halliwell B: The cytotoxicity of dopamine may be an artefact of cell culture. *J Neurochem* 2002, 81(3):414-421.
605. Chen Q, Espey MG, Sun AY, Lee JH, Krishna MC, Shacter E, Choyke PL, Pooput C, Kirk KL, Buettner GR et al: Ascorbate in pharmacologic concentrations selectively generates ascorbate radical and hydrogen peroxide in extracellular fluid in vivo. *Proc Natl Acad Sci U S A* 2007, 104(21):8749-8754.
606. Englard S, Seifter S: The biochemical functions of ascorbic acid. *Annu Rev Nutr* 1986, 6:365-406.
607. Oberley TD, Oberley LW: Antioxidant enzyme levels in cancer. *Histol Histopathol* 1997, 12(2):525-535.

608. Davies KJ: The broad spectrum of responses to oxidants in proliferating cells: a new paradigm for oxidative stress. *IUBMB Life* 1999, 48(1):41-47.
609. Riordan HD, Casciari JJ, Gonzalez MJ, Riordan NH, Miranda-Massari JR, Taylor P, Jackson JA: A pilot clinical study of continuous intravenous ascorbate in terminal cancer patients. *P R Health Sci J* 2005, 24(4):269-276.
610. Hoffer LJ, Levine M, Assouline S, Melnychuk D, Padayatty SJ, Rosadiuk K, Rousseau C, Robitaille L, Miller WH, Jr.: Phase I clinical trial of intravenous ascorbic acid in advanced malignancy. *Ann Oncol* 2008, 19(11):1969-1974.
611. Kimoto E, Tanaka H, Gytoku J, Morishige F, Pauling L: Enhancement of antitumor activity of ascorbate against Ehrlich ascites tumor cells by the copper:glycylglycylhistidine complex. *Cancer Res* 1983, 43(2):824-828.
612. Frei B, Yamamoto Y, Niclas D, Ames BN: Evaluation of an isoluminol chemiluminescence assay for the detection of hydroperoxides in human blood plasma. *Anal Biochem* 1988, 175(1):120-130.
613. Langlely RE, Burdett S, Tierney JF, Cafferty F, Parmar MK, Venning G: Aspirin and cancer: has aspirin been overlooked as an adjuvant therapy? *Br J Cancer* 2011, 105(8):1107-1113.
614. Baron JA: Epidemiology of non-steroidal anti-inflammatory drugs and cancer. *Prog Exp Tumor Res* 2003, 37:1-24.
615. Elwood PC, Gallagher AM, Duthie GG, Mur LA, Morgan G: Aspirin, salicylates, and cancer. *Lancet* 2009, 373(9671):1301-1309.
616. Sandler RS, Halabi S, Baron JA, Budinger S, Paskett E, Keresztes R, Petrelli N, Pipas JM, Karp DD, Loprinzi CL et al: A randomized trial of aspirin to prevent colorectal adenomas in patients with previous colorectal cancer. *N Engl J Med* 2003, 348(10):883-890.
617. Chan AT, Ogino S, Fuchs CS: Aspirin use and survival after diagnosis of colorectal cancer. *JAMA* 2009, 302(6):649-658.
618. Jacobs EJ, Thun MJ, Bain EB, Rodriguez C, Henley SJ, Calle EE: A large cohort study of long-term daily use of adult-strength aspirin and cancer incidence. *J Natl Cancer Inst* 2007, 99(8):608-615.
619. Din FV, Theodoratou E, Farrington SM, Tenesa A, Barnetson RA, Cetnarskyj R, Stark L, Porteous ME, Campbell H, Dunlop MG: Effect of aspirin and NSAIDs on risk and survival from colorectal cancer. *Gut* 2010, 59(12):1670-1679.

620. Holmes MD, Chen WY, Li L, Hertzmark E, Spiegelman D, Hankinson SE: Aspirin intake and survival after breast cancer. *J Clin Oncol* 2010, 28(9):1467-1472.
621. Kim KM, Song JJ, An JY, Kwon YT, Lee YJ: Pretreatment of acetylsalicylic acid promotes tumor necrosis factor-related apoptosis-inducing ligand-induced apoptosis by down-regulating BCL-2 gene expression. *J Biol Chem* 2005, 280(49):41047-41056.
622. Borthwick GM, Johnson AS, Partington M, Burn J, Wilson R, Arthur HM: Therapeutic levels of aspirin and salicylate directly inhibit a model of angiogenesis through a Cox-independent mechanism. *FASEB J* 2006, 20(12):2009-2016.
623. Shtivelband MI, Juneja HS, Lee S, Wu KK: Aspirin and salicylate inhibit colon cancer medium- and VEGF-induced endothelial tube formation: correlation with suppression of cyclooxygenase-2 expression. *J Thromb Haemost : JTH* 2003, 1(10):2225-2233.
624. Bos CL, Kodach LL, van den Brink GR, Diks SH, van Santen MM, Richel DJ, Peppelenbosch MP, Hardwick JC: Effect of aspirin on the Wnt/beta-catenin pathway is mediated via protein phosphatase 2A. *Oncogene* 2006, 25(49):6447-6456.
625. Din FV, Stark LA, Dunlop MG: Aspirin-induced nuclear translocation of NFkappaB and apoptosis in colorectal cancer is independent of p53 status and DNA mismatch repair proficiency. *Br J Cancer* 2005, 92(6):1137-1143.
626. Din FV, Dunlop MG, Stark LA: Evidence for colorectal cancer cell specificity of aspirin effects on NF kappa B signalling and apoptosis. *Br J Cancer* 2004, 91(2):381-388.
627. Pathi SS, Jutooru I, Chadalapaka G, Sreevalsan S, Anand S, Thatcher GR, Safe S: GT-094, a NO-NSAID, inhibits colon cancer cell growth by activation of a reactive oxygen species-microRNA-27a: ZBTB10-specificity protein pathway. *Mol Cancer Res* 2011, 9(2):195-202.
628. Abdelrahim M, Baker CH, Abbruzzese JL, Safe S: Tolfenamic acid and pancreatic cancer growth, angiogenesis, and Sp protein degradation. *J Natl Cancer Inst* 2006, 98(12):855-868.
629. Abdelrahim M, Safe S: Cyclooxygenase-2 inhibitors decrease vascular endothelial growth factor expression in colon cancer cells by enhanced degradation of Sp1 and Sp4 proteins. *Mol Pharmacol* 2005, 68(2):317-329.
630. Basha R, Baker CH, Sankpal UT, Ahmad S, Safe S, Abbruzzese JL, Abdelrahim M: Therapeutic applications of NSAIDS in cancer: special emphasis on tolfenamic acid. *Front Biosci (Schol Ed)* 2011, 3:797-805.

631. Abdelrahim M, Smith R, 3rd, Burghardt R, Safe S: Role of Sp proteins in regulation of vascular endothelial growth factor expression and proliferation of pancreatic cancer cells. *Cancer Res* 2004, 64(18):6740-6749.
632. Chadalapaka G, Jutooru I, Chintharlapalli S, Papineni S, Smith R, 3rd, Li X, Safe S: Curcumin decreases specificity protein expression in bladder cancer cells. *Cancer Res* 2008, 68(13):5345-5354.
633. Chadalapaka G, Jutooru I, Burghardt R, Safe S: Drugs that target specificity proteins downregulate epidermal growth factor receptor in bladder cancer cells. *Mol Cancer Res* 2010, 8(5):739-750.
634. Jutooru I, Chadalapaka G, Abdelrahim M, Basha MR, Samudio I, Konopleva M, Andreeff M, Safe S: Methyl 2-cyano-3,12-dioxooleana-1,9-dien-28-oate decreases specificity protein transcription factors and inhibits pancreatic tumor growth: role of microRNA-27a. *Mol Pharmacol* 2010, 78(2):226-236.
635. Jutooru I, Chadalapaka G, Lei P, Safe S: Inhibition of NFkappaB and pancreatic cancer cell and tumor growth by curcumin is dependent on specificity protein down-regulation. *J Biol Chem* 2010, 285(33):25332-25344.
636. Jutooru I, Chadalapaka G, Sreevalsan S, Lei P, Barhoumi R, Burghardt R, Safe S: Arsenic trioxide downregulates specificity protein (Sp) transcription factors and inhibits bladder cancer cell and tumor growth. *Exp Cell Res* 2010, 316(13):2174-2188.
637. Juarez Olguin H, Flores Perez J, Lares Asseff I, Loreda Abdala A, Carbajal Rodriguez L: Comparative pharmacokinetics of acetyl salicylic acid and its metabolites in children suffering from autoimmune diseases. *Biopharmaceutics & Drug Disposition* 2004, 25(1):1-7.
638. Nollet F, Berx G, Molemans F, van Roy F: Genomic organization of the human beta-catenin gene (CTNNB1). *Genomics* 1996, 32(3):413-424.
639. Yurochko AD, Mayo MW, Poma EE, Baldwin AS, Jr., Huang ES: Induction of the transcription factor Sp1 during human cytomegalovirus infection mediates upregulation of the p65 and p105/p50 NF-kappaB promoters. *J Virol* 1997, 71(6):4638-4648.
640. Wang YT, Chuang JY, Shen MR, Yang WB, Chang WC, Hung JJ: Sumoylation of specificity protein 1 augments its degradation by changing the localization and increasing the specificity protein 1 proteolytic process. *J Mol Biol* 2008, 380(5):869-885.

641. Chintharlapalli S, Papineni S, Lei P, Pathi S, Safe S: Betulinic acid inhibits colon cancer cell and tumor growth and induces proteasome-dependent and -independent downregulation of specificity proteins (Sp) transcription factors. *BMC Cancer* 2011, 11:371.
642. Chimienti F, Seve M, Richard S, Mathieu J, Favier A: Role of cellular zinc in programmed cell death: temporal relationship between zinc depletion, activation of caspases, and cleavage of Sp family transcription factors. *Biochem Pharmacol* 2001, 62(1):51-62.
643. Seve M, Chimienti F, Richard S, Mathieu J, Favier A: Intracellular zinc chelation induces apoptosis, caspases activation, and transcription factors degradation in Jurkat and HeLa cells. In: *Trace Elements in Man and Animals 10*. Edited by Roussel AM, Favier AE, Anderson RA. New York: Kluwer Academic/Plenum Publishers; 2000: 1003-1007.
644. Hunt RH, Lanas A, Stichtenoth DO, Scarpignato C: Myths and facts in the use of anti-inflammatory drugs. *Ann Med* 2009, 41(6):423-437.
645. Chintharlapalli S, Papineni S, Ramaiah SK, Safe S: Betulinic acid inhibits prostate cancer growth through inhibition of specificity protein transcription factors. *Cancer Res* 2007, 67(6):2816-2823.
646. Piedrafita FJ, Pfahl M: Retinoid-induced apoptosis and Sp1 cleavage occur independently of transcription and require caspase activation. *Mol Cell Biol* 1997, 17(11):6348-6358.
647. Baslas RK, Zamani R, Nomani AA: Studies on the metal-complex of acetyl salicylic acid (aspirin). *Experientia* 1979, 35(4):455-456.
648. Kim EY, Chang SY, Chung JM, Ryu BR, Joo CK, Moon HS, Kang K, Yoon SH, Han PL, Gwag BJ: Attenuation of Zn²⁺ neurotoxicity by aspirin: role of N-type Ca²⁺ channel and the carboxyl acid group. *Neurobiol Dis* 2001, 8(5):774-783.
649. Saito H, Sakai T, Ueno K, Kitagawa H: Influence of maternal drug metabolism on the fetal toxicity induced by acetylsalicylic acid. *J Toxicol Sci* 1982, 7(3):177-184.
650. Ghezzi F, Cesano L, Mognetti B, Pesce E, Pirro E, Corvetti G, Berta GN, Zingaro B, Di Carlo F: Salicylate inhibition of rat mammary carcinogenesis and angiogenesis in female rat compatible with misoprostol administration. *Intl J Oncol* 2005, 26(3):697-702.
651. Wang D, Dubois RN: The role of COX-2 in intestinal inflammation and colorectal cancer. *Oncogene* 2010, 29(6):781-788.

652. Cuzick J, Otto F, Baron JA, Brown PH, Burn J, Greenwald P, Jankowski J, La Vecchia C, Meyskens F, Senn HJ et al: Aspirin and non-steroidal anti-inflammatory drugs for cancer prevention: an international consensus statement. *Lancet Oncol* 2009, 10(5):501-507.
653. Grosch S, Maier TJ, Schiffmann S, Geisslinger G: Cyclooxygenase-2 (COX-2)-independent anticarcinogenic effects of selective COX-2 inhibitors. *J Natl Cancer Inst* 2006, 98(11):736-747.
654. Jacobs EJ, Thun MJ, Bain EB, Rodriguez C, Henley SJ, Calle EE: A large cohort study of long-term daily use of adult-strength aspirin and cancer incidence. *J Natl Cancer Inst* 2007, 99(8):608-615.
655. Baron JA: Epidemiology of non-steroidal anti-inflammatory drugs and cancer. *Prog Exp Tumor Res* 2003, 37:1-24.
656. Baron JA, Cole BF, Sandler RS, Haile RW, Ahnen D, Bresalier R, McKeown-Eyssen G, Summers RW, Rothstein R, Burke CA et al: A randomized trial of aspirin to prevent colorectal adenomas. *N Engl J Med* 2003, 348(10):891-899.
657. Sandler RS, Halabi S, Baron JA, Budinger S, Paskett E, Keresztes R, Petrelli N, Pipas JM, Karp DD, Loprinzi CL et al: A randomized trial of aspirin to prevent colorectal adenomas in patients with previous colorectal cancer. *N Engl J Med* 2003, 348(10):883-890.
658. Nugent KP, Farmer KC, Spigelman AD, Williams CB, Phillips RK: Randomized controlled trial of the effect of sulindac on duodenal and rectal polyposis and cell proliferation in patients with familial adenomatous polyposis. *Br J Surg* 1993, 80(12):1618-1619.
659. Bresalier RS, Sandler RS, Quan H, Bolognese JA, Oxenius B, Horgan K, Lines C, Riddell R, Morton D, Lanos A et al: Cardiovascular events associated with rofecoxib in a colorectal adenoma chemoprevention trial. *N Engl J Med* 2005, 352(11):1092-1102.
660. Jutooru I, Chadalapaka G, Lei P, Safe S: Inhibition of NFkappaB and pancreatic cancer cell and tumor growth by curcumin is dependent on specificity protein down-regulation. *J Biol Chem* 2010, 285(33):25332-25344.
661. Jutooru I, Chadalapaka G, Abdelrahim M, Basha MR, Samudio I, Konopleva M, Andreeff M, Safe S: Methyl 2-cyano-3,12-dioxoleana-1,9-dien-28-oate decreases specificity protein transcription factors and inhibits pancreatic tumor growth: role of microRNA-27a. *Mol Pharmacol* 2010, 78(2):226-236.
662. Jutooru I, Chadalapaka G, Sreevalsan S, Lei P, Barhoumi R, Burghardt R, Safe S: Arsenic trioxide downregulates specificity protein (Sp) transcription factors and inhibits bladder cancer cell and tumor growth. *Exp Cell Res* 2010, 316(13):2174-2188.

663. Liu X, Jutooru I, Lei P, Kim K, Lee SO, Brents LK, Prather PL, Safe SH: Betulinic Acid Targets YY1 and ErbB2 through Cannabinoid Receptor-dependent Disruption of MicroRNA-27a:ZBTB10 in Breast Cancer. *Mol Cancer Ther* 2012.
664. Tatsukawa H, Sano T, Fukaya Y, Ishibashi N, Watanabe M, Okuno M, Moriwaki H, Kojima S: Dual induction of caspase 3- and transglutaminase-dependent apoptosis by acyclic retinoid in hepatocellular carcinoma cells. *Mol Cancer* 2011, 10:4.
665. Chimienti F, Seve M, Richard S, Mathieu J, Favier A: Role of cellular zinc in programmed cell death: temporal relationship between zinc depletion, activation of caspases, and cleavage of Sp family transcription factors. *Biochem Pharmacol* 2001, 62(1):51-62.
666. Jiang NY, Woda BA, Banner BF, Whalen GF, Dresser KA, Lu D: Sp1, a new biomarker that identifies a subset of aggressive pancreatic ductal adenocarcinoma. *Cancer Epidemiol Biomarkers Prev* 2008, 17(7):1648-1652.
667. Wang L, Wei D, Huang S, Peng Z, Le X, Wu TT, Yao J, Ajani J, Xie K: Transcription factor Sp1 expression is a significant predictor of survival in human gastric cancer. *Clin Cancer Res* 2003, 9(17):6371-6380.
668. Adrian GS, Seto E, Fischbach KS, Rivera EV, Adrian EK, Herbert DC, Walter CA, Weaker FJ, Bowman BH: YY1 and Sp1 transcription factors bind the human transferrin gene in an age-related manner. *J Gerontol A Biol Sci Med Sci* 1996, 51(1):B66-75.
669. Chintharlapalli S, Papineni S, Lee SO, Lei P, Jin UH, Sherman SI, Santarpia L, Safe S: Inhibition of pituitary tumor-transforming gene-1 in thyroid cancer cells by drugs that decrease specificity proteins. *Mol Carcinog* 2011, 50(9):655-667.
670. Chadalapaka G, Jutooru I, Burghardt R, Safe S: Drugs that target specificity proteins downregulate epidermal growth factor receptor in bladder cancer cells. *Mol Cancer Res* 2010, 8(5):739-750.
671. Chintharlapalli S, Papineni S, Ramaiah SK, Safe S: Betulinic acid inhibits prostate cancer growth through inhibition of specificity protein transcription factors. *Cancer Res* 2007, 67(6):2816-2823.
672. Rejholec V, Vapaatalo H, Tokola O, Gothoni G: Tolfenamic acid in the treatment of rheumatoid arthritis. *Scand J Rheumatol Suppl* 1979(24):9-12.
673. Dinarello CA: Anti-inflammatory agents: present and future. *Cell* 2010, 140(6):935-950.

674. Cole BF, Logan RF, Halabi S, Benamouzig R, Sandler RS, Grainge MJ, Chaussade S, Baron JA: Aspirin for the chemoprevention of colorectal adenomas: meta-analysis of the randomized trials. *J Natl Cancer Inst* 2009, 101(4):256-266.
675. Grau MV, Sandler RS, McKeown-Eyssen G, Bresalier RS, Haile RW, Barry EL, Ahnen DJ, Gui J, Summers RW, Baron JA: Nonsteroidal anti-inflammatory drug use after 3 years of aspirin use and colorectal adenoma risk: observational follow-up of a randomized study. *J Natl Cancer Inst* 2009, 101(4):267-276.
676. Baron JA, Sandler RS, Bresalier RS, Quan H, Riddell R, Lanas A, Bolognese JA, Oxenius B, Horgan K, Loftus S et al: A randomized trial of rofecoxib for the chemoprevention of colorectal adenomas. *Gastroenterology* 2006, 131(6):1674-1682.
677. Arber N, Eagle CJ, Spicak J, Racz I, Dite P, Hajer J, Zavoral M, Lechuga MJ, Gerletti P, Tang J et al: Celecoxib for the prevention of colorectal adenomatous polyps. *N Engl J Med* 2006, 355(9):885-895.
678. Bertagnolli MM, Eagle CJ, Zauber AG, Redston M, Solomon SD, Kim K, Tang J, Rosenstein RB, Wittes J, Corle D et al: Celecoxib for the prevention of sporadic colorectal adenomas. *N Engl J Med* 2006, 355(9):873-884.
679. Ouyang N, Williams JL, Rigas B: NO-donating aspirin inhibits angiogenesis by suppressing VEGF expression in HT-29 human colon cancer mouse xenografts. *Carcinogenesis* 2008, 29(9):1794-1798.
680. Bratasz A, Selvendiran K, Wasowicz T, Bobko A, Khramtsov VV, Ignarro LJ, Kuppusamy P: NCX-4040, a nitric oxide-releasing aspirin, sensitizes drug-resistant human ovarian xenograft tumors to cisplatin by depletion of cellular thiols. *J Transl Med* 2008, 6:9.
681. Kashfi K, Rigas B: The mechanism of action of nitric oxide-donating aspirin. *Biochem Biophys Res Commun* 2007, 358(4):1096-1101.
682. Benamouzig R, Deyra J, Martin A, Girard B, Jullian E, Piednoir B, Couturier D, Coste T, Little J, Chaussade S: Daily soluble aspirin and prevention of colorectal adenoma recurrence: one-year results of the APACC trial. *Gastroenterology* 2003, 125(2):328-336.
683. Chintharlapalli S, Papineni S, Abdelrahim M, Abudayyeh A, Jutooru I, Chadalapaka G, Wu F, Mertens-Talcott S, Vanderlaag K, Cho SD et al: Oncogenic microRNA-27a is a target for anticancer agent methyl 2-cyano-3,11-dioxo-18beta-olean-1,12-dien-30-oate in colon cancer cells. *Int J Cancer* 2009, 125(8):1965-1974.

684. Mertens-Talcott SU, Chintharlapalli S, Li X, Safe S: The oncogenic microRNA-27a targets genes that regulate specificity protein transcription factors and the G2-M checkpoint in MDA-MB-231 breast cancer cells. *Cancer Res* 2007, 67(22):11001-11011.
685. Costoya JA: Functional analysis of the role of POK transcriptional repressors. *Brief Funct Genomic Proteomic* 2007, 6(1):8-18.
686. Tillotson LG: RIN ZF, a novel zinc finger gene, encodes proteins that bind to the CACC element of the gastrin promoter. *J Biol Chem* 1999, 274(12):8123-8128.
687. Levine M, Espey MG, Chen Q: Losing and finding a way at C: new promise for pharmacologic ascorbate in cancer treatment. *Free Radic Biol Med* 2009, 47(1):27-29.
688. Padayatty SJ, Katz A, Wang Y, Eck P, Kwon O, Lee JH, Chen S, Corpe C, Dutta A, Dutta SK et al: Vitamin C as an antioxidant: evaluation of its role in disease prevention. *J Am Coll Nutr* 2003, 22(1):18-35.
689. Cameron E, Pauling L: Supplemental ascorbate in the supportive treatment of cancer: Prolongation of survival times in terminal human cancer. *Proc Natl Acad Sci U S A* 1976, 73(10):3685-3689.
690. Verrax J, Delvaux M, Beghein N, Taper H, Gallez B, Buc Calderon P: Enhancement of quinone redox cycling by ascorbate induces a caspase-3 independent cell death in human leukaemia cells. An in vitro comparative study. *Free Radic Res* 2005, 39(6):649-657.
691. Casciari JJ, Riordan NH, Schmidt TL, Meng XL, Jackson JA, Riordan HD: Cytotoxicity of ascorbate, lipoic acid, and other antioxidants in hollow fibre in vitro tumours. *Br J Cancer* 2001, 84(11):1544-1550.
692. Park CH, Amare M, Savin MA, Hoogstraten B: Growth suppression of human leukemic cells in vitro by L-ascorbic acid. *Cancer Res* 1980, 40(4):1062-1065.
693. Prasad KN, Sinha PK, Ramanujam M, Sakamoto A: Sodium ascorbate potentiates the growth inhibitory effect of certain agents on neuroblastoma cells in culture. *Proc Natl Acad Sci U S A* 1979, 76(2):829-832.
694. Verrax J, Calderon PB: Pharmacologic concentrations of ascorbate are achieved by parenteral administration and exhibit antitumoral effects. *Free Radic Biol Med* 2009, 47(1):32-40.
695. Duconge J, Miranda-Massari JR, Gonzalez MJ, Jackson JA, Warnock W, Riordan NH: Pharmacokinetics of vitamin C: insights into the oral and intravenous administration of ascorbate. *P R Health Sci J* 2008, 27(1):7-19.

696. Duarte TL, Almeida GM, Jones GD: Investigation of the role of extracellular H₂O₂ and transition metal ions in the genotoxic action of ascorbic acid in cell culture models. *Toxicol Lett* 2007, 170(1):57-65.
697. Hu J, Fang J, Dong Y, Chen SJ, Chen Z: Arsenic in cancer therapy. *Anticancer Drugs* 2005, 16(2):119-127.
698. Miller WH, Jr., Schipper HM, Lee JS, Singer J, Waxman S: Mechanisms of action of arsenic trioxide. *Cancer Res* 2002, 62(14):3893-3903.
699. Shao W, Fanelli M, Ferrara FF, Riccioni R, Rosenauer A, Davison K, Lamph WW, Waxman S, Pelicci PG, Lo Coco F et al: Arsenic trioxide as an inducer of apoptosis and loss of PML/RAR alpha protein in acute promyelocytic leukemia cells. *J Natl Cancer Inst* 1998, 90(2):124-133.
700. Dynan WS, Tjian R: The promoter-specific transcription factor Sp1 binds to upstream sequences in the SV40 early promoter. *Cell* 1983, 35(1):79-87.
701. Lee YJ, Shacter E: Hydrogen peroxide inhibits activation, not activity, of cellular caspase-3 in vivo. *Free Radic Biol Med* 2000, 29(7):684-692.
702. Lee YJ, Shacter E: Oxidative stress inhibits apoptosis in human lymphoma cells. *J Biol Chem* 1999, 274(28):19792-19798.
703. Kumar S, Sun X, Wiseman DA, Tian J, Umapathy NS, Verin AD, Black SM: Hydrogen peroxide decreases endothelial nitric oxide synthase promoter activity through the inhibition of Sp1 activity. *DNA Cell Biol* 2009, 28(3):119-129.
704. Wang X, Wang J, Lin S, Geng Y, Jiang B: Sp1 is involved in H₂O₂-induced PUMA gene expression and apoptosis in colorectal cancer cells. *J Exp Clin Cancer Res* 2008, 27:44.
705. Dasari A, Bartholomew JN, Volonte D, Galbiati F: Oxidative stress induces premature senescence by stimulating caveolin-1 gene transcription through p38 mitogen-activated protein kinase/Sp1-mediated activation of two GC-rich promoter elements. *Cancer Res* 2006, 66(22):10805-10814.
706. Chu S, Ferro TJ: Identification of a hydrogen peroxide-induced PP1-JNK1-Sp1 signaling pathway for gene regulation. *Am J Physiol Lung Cell Mol Physiol* 2006, 291(5):L983-992.
707. Ryu H, Lee J, Zaman K, Kubilis J, Ferrante RJ, Ross BD, Neve R, Ratan RR: Sp1 and Sp3 are oxidative stress-inducible, antideath transcription factors in cortical neurons. *J Neurosci* 2003, 23(9):3597-3606.

VITA

Name: Satya Sreehari Pathi

Mailing Address: Department of Veterinary Physiology & Pharmacology
4466 TAMU, College Station, TX 77843-4466

Education:

August 2012 Doctor of Philosophy in Toxicology
Texas A&M University, College Station, TX

December 2008 Master of Science in Biology
Texas A&M University, Kingsville, TX
Thesis: Functional analysis of zRICH, a nerve regeneration
related protein in zebrafish
Thesis Advisor: Rafael Perez-Ballesterro

December 2005 Bachelor of Veterinary Medicine (equivalent to DVM)
Acharya N. G. Ranga Agricultural University, India