

**PLANT-SOIL INTERACTIONS, WEED CONTROL, AND RICE TOLERANCE  
AS AFFECTED BY SAFLUFENACIL**

A Dissertation

by

EDINALVO RABAIOLI CAMARGO

Submitted to the Office of Graduate Studies of  
Texas A&M University  
in partial fulfillment of the requirements for the degree of

DOCTOR OF PHILOSOPHY

August 2012

Major Subject: Agronomy

**PLANT-SOIL INTERACTIONS, WEED CONTROL, AND RICE TOLERANCE  
AS AFFECTED BY SAFLUFENACIL**

A Dissertation

by

EDINALVO RABAIOLI CAMARGO

Submitted to the Office of Graduate Studies of  
Texas A&M University  
in partial fulfillment of the requirements for the degree of

DOCTOR OF PHILOSOPHY

Approved by:

Chair of Committee,	Scott A. Senseman
Committee Members,	Garry N. McCauley
	James M. Chandler
	J. Tom Cothren
	Rodney W. Bovey
Head of Department,	David D. Baltensperger

August 2012

Major Subject: Agronomy

**ABSTRACT**

Plant-Soil Interactions, Weed Control, and Rice Tolerance as Affected by Saflufenacil.

(August 2012)

Edinalvo Rabaioli Camargo, B.S., Universidade Federal de Santa Maria, Brazil;

M.S., Universidade Federal de Santa Maria, Brazil

Chair of Advisory Committee: Dr. Scott Allen Senseman

Saflufenacil is a new herbicide for broadleaf weed control. Limited information is available for crop tolerance, weed control and herbicide behavior in the rice environment. Studies were designed to 1 and 2) evaluate rice tolerance and weed control to saflufenacil in combination with clomazone and imazethapyr; 3) evaluate the absorption and translocation of imazethapyr and saflufenacil in weed species 4) assess saflufenacil degradation and persistence in soils; and 5) investigate the use of reference compounds during the determination of pesticide adsorption ( $K_d$ ).

None or minimal rice injury was observed from preemergence (PRE) application of saflufenacil. Intense injury (68%) was noted with combinations of clomazone ( $505 \text{ g ha}^{-1}$ ) applied PRE and saflufenacil ( $50 \text{ g ha}^{-1}$ ) applied postemergence (POST). Similarly, rice injury up to 83% was observed in earlier evaluations when saflufenacil was applied POST with imazethapyr. However, subsequent evaluations indicated rice recovery from herbicide treatments. Combination of saflufenacil with imazethapyr resulted in hemp sesbania control  $\geq 88\%$  and red rice control of 100%. Rice yield was not adversely

altered by the herbicide treatments used in the clomazone and imazethapyr weed control programs.

Imazethapyr plus saflufenacil provided a greater uptake (30%) and translocation (35%) of  $^{14}\text{C}$ -imazethapyr than imazethapyr alone in the TX4 red rice. Absorption of  $^{14}\text{C}$ -saflufenacil ranged from approximately 40 to 60% in hemp sesbania plants. At 12 and 24 hours after treatment a greater percentage of the absorbed saflufenacil was quantified above the treated leaf at the two lower light intensities. Similar trends were observed for basipetal movement of saflufenacil.

An accelerated solvent extraction method was developed to extract saflufenacil from soil. Half-life averaged among soils was 59 and 33 days for saturated and field capacity, respectively. Saflufenacil persistence in the environment was 2 to 3 times longer under flooded conditions for most of the studied soils. Adsorption values were affected by soil to solution ratios, particularly when the soil-pesticide interaction resulted in  $K_d$  values  $>$  than  $2 \text{ mL g}^{-1}$ . The use of reference compounds during  $K_d$  estimation allowed for calculation of a conceptual adsorption window generating a more comprehensive set of data with alternatives for comparison of soils and methods.

## **DEDICATION**

To my beloved wife, Síglia, who accepted the challenges of coming to US.

To my parents, who taught me to work honorably to achieve my dreams.

To my sister, Eliete, who will be always my “little sister”.

To all my family in Brazil, and to the Brazilian people.

## ACKNOWLEDGEMENTS

I would like to thank Dr. Senseman for the opportunity to come to Texas A&M University, for his example of dedication and caring, and for his professional, scientific and personal support and guidance over the years. I would like to thank my committee members, Drs. Garry McCauley, Mike Chandler, Tom Cothren and Rodney Bovey for all their help and contributions. I am also thankful to CNPq, Conselho Nacional de Desenvolvimento Científico e Tecnológico, Brazil for the four-year scholarship, to the College of Agriculture and Life Sciences for the Tom Slick Graduate Research Fellowship, and to BASF Company for funding the research.

I would like to thank Dr. Rick Haney for his help in the carbon dioxide evolution experiments and for providing soil samples, and to Dr. Dale Shaner and Dr. Kyle Keller for helping to expand the array of soil series in the adsorption studies. I would like to acknowledge Dr. Brad Guice, Dr. Rex Liebl, John Harden, Steve Bowe, and Tom Holt for their valuable contributions during the organization of the studies and for the opportunity to work with saflufenacil. Special thanks go to Dr. Kathy Carson for all her help, assistance, and attention during my research. I am also grateful to Drs. Enio Marchesan, Luis Antonio de Avila, Sérgio Marchado and Leandro Souza da Silva for their educational training and professional guidance during my previous degrees.

I would like to especially thank my wife, Sígria Camargo, for all her support, love, dedication, encouragement, and most importantly, lifelong friendship. Sígria, thanks for taking an uncertain path when coming to US with me and for staying by my

side every step of the way. I am very thankful to my father, Neri de Camargo, and my mother, Odete Maria Rabaioli Camargo, who taught me the simplest by the fundamental things in life, to love, to respect, to persist, and to be honest. Dad, Mom and sister Eliete, thank you for your love, patience and for understanding the time I have been away during my academic degrees. Also, I would like to thank all my family and friends in Brazil and the new friends/family I have met in US.

I want to express my appreciation to the staff members at the Texas A&M AgriLife Research and Extension Center located at Eagle Lake and Beaumont, TX and to Antonio Manriquez, Andrew Lemond, Catarine Markus and Mariah Marques for their assistance during the conduction of the experiments. Thanks also to my fellow graduate students, especially Dr. Sarah Lancaster, Dr. Sam Willingham, Dr. Nyland Falkenberg, Benjamin McKnight, Aaron Turner, Todd Cogdill, Frederico Barros, Murilo Maeda and Andrea Maeda for their support and companionship.

## TABLE OF CONTENTS

	Page
ABSTRACT .....	iii
DEDICATION .....	v
ACKNOWLEDGEMENTS .....	vi
TABLE OF CONTENTS .....	viii
LIST OF FIGURES .....	x
LIST OF TABLES .....	xiv
 CHAPTER	
I INTRODUCTION .....	1
II RICE TOLERANCE TO SAFLUFENACIL IN CLOMAZONE WEED CONTROL PROGRAM.....	6
Introduction .....	6
Material and Methods.....	10
Results and Discussion.....	14
Conclusions .....	26
III RICE ( <i>Oryza sativa</i> L.) RESPONSE AND WEED CONTROL FROM TANK-MIX APPLICATIONS OF SAFLUFENACIL AND IMAZETHAPYR.....	28
Introduction .....	28
Material and Methods.....	31
Results and Discussion.....	35
Conclusions .....	44
IV INTERACTION BETWEEN SAFLUFENACIL AND IMAZETHAPYR IN RED RICE ( <i>Oryza</i> ssp.) AND HEMP SESBANIA ( <i>Sesbania exaltata</i> ) AS AFFECTED BY LIGHT INTENSITY.....	45
Introduction .....	45
Materials and Methods .....	49
Results and Discussion.....	55



CHAPTER	Page
Conclusions .....	70
V DEGRADATION OF SAFLUFENACIL AS AFFECTED BY MOISTURE CONTENT AND SOIL CHARACTERISTICS .....	72
Introduction .....	72
Materials and Methods .....	74
Results and Discussion .....	83
Conclusions .....	95
VI DEVELOPMENT OF AN ADSORPTION WINDOW FOR PESTICIDES: A POTENTIAL ALTERNATIVE TO COMPARING SOIL ADSORPTION VALUES .....	97
Introduction .....	97
Materials And Methods .....	103
Results And Discussion .....	115
Conclusions .....	129
VII SUMMARY AND CONCLUSIONS .....	131
REFERENCES .....	136
VITA .....	153

## LIST OF FIGURES

	Page
Figure 1. Rice symptoms from clomazone alone (B) and clomazone plus saflufenacil applied preemergence (C) and postemergence (D). Untreated check is represented in box A. Pictures were taken in different rice stages. ....	19
Figure 2. Grain yield ( $t\ ha^{-1}$ ) in response to preemergence (A) and postemergence (B) application of saflufenacil following preemergence application of clomazone. Data were averaged across clomazone rates. Means were not different according to F-test at $p \leq 0.05$ . ....	25
Figure 3. Treatment applications at 2- to 3-leaf stage (EPOST) and 4- to 6-leaf stage (LPOST) with subsequent assessment intervals in days after saflufenacil application (DAA). Applications and/or evaluations were conducted where color changes occur on the bars. Number inside the bars represents the numbers of days after emergence for the application of the treatments and/or execution of the visual assessment. Evaluations conducted for the same bar color were used for statistical comparisons. ....	33
Figure 4. Rice grain yield ( $t\ ha^{-1}$ ) in response to postemergence tank-mix applications of saflufenacil and imazethapyr at 2- to 3-leaf stage (EPOST) and 4- to 6-leaf stage (LPOST). Triclopyr ( $420\ g\ a.e.\ ha^{-1}$ ) was applied LPOST to plots receiving imazethapyr alone (IA). Data average across years. No significant difference according to the Tukey's test ( $p \leq 0.05$ ). ....	43
Figure 5. Imazethapyr absorption (A) and translocation (B) in red rice plants at 1, 6, 24, 72 and 168 hours after treatments. Data were averaged among herbicides and light intensity treatments. Bars represent 95% confidence intervals of 6 replications. ....	56
Figure 6. Imazethapyr absorption (A) and translocation (B) in red rice plants treated with imazethapyr alone or imazethapyr plus saflufenacil. Data were averaged among light intensity treatments and harvest timings. Letters represent significant differences according to Tukey's Test ( $p \leq 0.05$ ). ....	58
Figure 7. Percentage of absorbed $^{14}C$ -Imazethapyr quantified above the treated leaf in red rice plants after herbicide application. Data were averaged among light intensities of 106, 259, 677, and $1066\ \mu mol\ m^{-2}\ s^{-1}$ . Bars represent 95% confidence interval of 6 replications. Regression equations for imazethapyr alone and imazethapyr plus saflufenacil are $y = (19.49x)/(8.40+x)$ and $y = (23.85x)/(11.41+x)$ , respectively. ....	60

- Figure 8. Percentage of absorbed  $^{14}\text{C}$ -Imazethapyr quantified in the aerial parts below the treated leaf in red rice plants after application of herbicide treatments. Data were averaged among herbicide treatments. Bars represent 95% confidence intervals of 6 replications. ....61
- Figure 9. Percentage of absorbed  $^{14}\text{C}$ -Imazethapyr quantified in the root system of red rice plants after application of imazethapyr (A) and imazethapyr plus saflufenacil (B). ....63
- Figure 10. Saflufenacil absorption in hemp sesbania plants under four (4) light intensities conditions treated with saflufenacil alone or saflufenacil plus imazethapyr. Data were averaged among harvest times. Bars represent 95% confidence intervals of 6 replications. ....66
- Figure 11. Translocation of saflufenacil in hemp sesbania plants affected by harvest timing (A) and light intensity (B). Bars represent 95% confidence intervals of 6 replications. ....68
- Figure 12. Percentage of absorbed  $^{14}\text{C}$ -saflufenacil quantified above the treated leaf (A) and aerial parts below the treated leaf (B) in hemp sesbania plants after herbicide application. Data were averaged among herbicide treatments. Bars represent confidence interval of 6 replications. ....69
- Figure 13. Schematic representation of apparatus used to quantify microbial respiration. Sealed chambers containing combination of soil by water treatments (1) were coupled with an infrared  $\text{CO}_2$  detector (2). Arrows represent the air system flow. Soda lime reservoir (3), solenoid switch (4=in; 5=out). ....82
- Figure 14. Carbon evolution in rice soils under saturated (A) and field capacity (B) moisture conditions during 716 hours (~30 days). Saflufenacil was applied at  $2000 \text{ g ha}^{-1}$  ( $2.67 \mu\text{g g soil}^{-1}$ ). Results are average of four replications. ....84
- Figure 15. Fitted equations for cumulative carbon mineralization at Nada (---), Morey (—), Crowley (···), and Gilbert (· — ·) rice soils under saturation (A) and field capacity (B) moisture conditions. Saflufenacil was applied at  $2000 \text{ g ha}^{-1}$  ( $2.67 \mu\text{g g soil}^{-1}$ ). ....87
- Figure 16. Saflufenacil recovery from soil samples used to control efficiency of accelerated solvent extraction (ASE) method (50 C, 10.3 MPa, acetonitrile, 3 static cycles). Bars represent positive side of 95% confidence intervals of 5 replications. ....88

- Figure 17. Patterns of saflufenacil degradation under saturation and field capacity moisture conditions for Nada (A), Morey (B), Crowley (C), and Gilbert (D) soil series. Saflufenacil was applied at  $2000 \text{ g ha}^{-1}$  ( $2.67 \mu\text{g g soil}^{-1}$ ). Bars represent 95% confidence intervals of five replications..... 90
- Figure 18. First-order degradation rate of saflufenacil under saturation and field capacity moisture conditions for Nada (A), Morey (B), Crowley (C), and Gilbert (D) soil series. Saflufenacil was applied at  $2000 \text{ g ha}^{-1}$  ( $2.67 \mu\text{g g soil}^{-1}$ ). Estimated parameters of polynomial equations are listed in the Table 13. .... 91
- Figure 19. Conceptual results for studying adsorption a specific molecule ( $K_{d(x)}$ ) simultaneously with pesticides of relatively weak ( $K_{d(\min)}$ ) and strong ( $K_{d(\max)}$ ) adsorptive in the soil. Approach generates potential for calculating an adsorption window ( $K_{d(\max)} - K_{d(\min)}$ ) which may expand and contract depending on soil sorption components. Also, the use of multiple compounds allows comparisons across different soil to solution ratios by accounting for the relative variation in pesticide adsorption. .... 102
- Figure 20. Herbicide concentrations ( $\text{ng mL}^{-1}$ ) obtained after interpolating with individual calibration curves (A) following dilution correction for adding six proportions of acetonitrile in the final sample volume (B). Bars represent 95% confidence intervals of 4 replications. .... 111
- Figure 21. Adsorption coefficient for 2,4-D (A) and pH of soil samples (B) after equilibration for 24 hours in solution with (shaded dots) and without (opened dots) calcium chloride (0.01 M). Experiments were conducted using a 1:5 soil to solution ratio. Bars represent 95% confidence intervals of 5 replications. In the Figure 21A, vertical axis has a 3 and 10-unit scale interval before and after the break, respectively. Dotted line represents pH 7.0 in the Figure 21B. .... 116
- Figure 22. Adsorption coefficient ( $K_d$ ) of five herbicides for selected soil samples determined using three different soil to solution ratios and accelerated solvent extraction (ASE). A, Nada; B, Morey; C, Crowley, D, Lincoln, E, Candor III; F, Olney; G, Houston Black; H, Condor I; I, Gilbert; J, Arapahoe. Bars represent positive side of 95% confidence intervals. Vertical axes have a different scale interval before the break. Figure 22J does not have a scale break. Boxes represent the difference from the *S*-metolachlor ( $K_{d(S\text{-meto})}$ ) and saflufenacil ( $K_{d(\text{safi})}$ ) adsorption coefficients..... 121
- Figure 23. Adjusted linear regression for relative length of the adsorption window (AW, difference from the *S*-metolachlor ( $K_{d(S\text{-meto})}$ ) and saflufenacil

( $K_{d(\text{safl})}$ ) adsorption values) as a function of organic carbon content in soil samples. A, ASE; B, 1:3; C, 1:5; D, 1:10. Bars represent 95% confidence intervals..... 125

Figure 24. Adsorption relativity coefficient (ARC) for 2,4-D (A), atrazine (B) and clomazone (C) estimated for each soil series as a function of soil to solution ratio and ASE methodology. Index represents the relative position of each compound with relation of the adsorption windows. ARC was not calculated for *S*-metolachlor and saflufenacil as these two herbicides provided the maximum and minimum  $K_d$  values in most of the samples. Bars represent 95% confidence intervals..... 128

## LIST OF TABLES

	Page
Table 1. <i>P</i> values for multiple assessments of visible injury, yield and whole grain for preemergence (PRE) and postemergence (POST) applications of saflufenacil.....	15
Table 2. Rice ( <i>Oryza sativa</i> L.) visible injury at 10 days after emergence (DAE) and 22 DAE in 2009 and 15 DAE in 2010 in response to saflufenacil and clomazone applied preemergence. Saflufenacil results were averaged across clomazone rates and clomazone results were averaged across saflufenacil rates.....	16
Table 3. Rice ( <i>Oryza sativa</i> L.) visible injury at 22 DAE in response to saflufenacil and clomazone applied preemergence. Data represent an interaction between rates of saflufenacil and clomazone in 2010.....	17
Table 4. Visible rice ( <i>Oryza sativa</i> L.) injury at 3, 8, 18 and 24 days after application (DAA) in response to postemergence application (4- to 6-leaf stage, V4-V6) of saflufenacil following preemergence application of clomazone. Data represents an interaction between rates of saflufenacil and clomazone for experiment conducted in 2009.....	20
Table 5. Rice ( <i>Oryza sativa</i> L.) visible injury at 6 and 12 days after application (DAA) in response to postemergence application (4- to 6-leaf stage, V4-V6) of saflufenacil following preemergence application of clomazone. Saflufenacil results were averaged across clomazone rates and clomazone results were averaged across saflufenacil rates.....	23
Table 6. Rice ( <i>Oryza sativa</i> L.) visible injury in response to postemergence tank-mix applications of saflufenacil (S) and imazethapyr (I) at different growth stages. <sup>a</sup> .....	36
Table 7. Hemp sesbania control ( <i>Sesbania exaltata</i> ) in response to postemergence tank-mix applications of saflufenacil (S) and imazethapyr (I) at different growth stages. Data average across years. <sup>a</sup> .....	39
Table 8. Red rice ( <i>Oryza sativa</i> L.) control in response to postemergence tank-mix applications of saflufenacil (S) and imazethapyr (I) at different growth stages. <sup>a</sup> .....	41
Table 9. <i>F</i> -values of ANOVA for absorption (AB), translocation (TR), and distribution of absorbed imazethapyr in TX4 red rice ( <i>Oryza</i> spp.) ecotype. Percentage of absorbed herbicide located above-treated leaf (ATL), in the	

aerial parts of the plant below-treated leaf (BTL), and in the root system (RS) was used to study imazethapyr distribution. ....	54
Table 10. <i>F</i> -values of ANOVA for absorption (AB), translocation (TR), and distribution of absorbed saflufenacil in hemp sesbania ( <i>Sesbania exaltata</i> ). Percentage of absorbed herbicide located above-treated leaf (ATL), in the aerial parts of the plant below-treated leaf (BTL), and in the root system (RS) was used to study saflufenacil distribution.....	55
Table 11. Samples characterization for soils collected in Eagle Lake, TX (EL), Beaumont, TX (BM), Crowley, LA (CR), and Gilbert, LA (GB). <sup>a</sup> .....	75
Table 12. Gravimetric water content ( $\theta_g$ ) estimated using -33 kPa (field capacity) and 0 kPa (saturation) as the water potential of the soil samples. ....	77
Table 13. Parameters for first-order degradation rates of saflufenacil under saturation and field capacity soil conditions. <sup>a</sup> .....	92
Table 14. First-order rate constant ( <i>k</i> ), half-life ( $t_{1/2}$ ), 95% confidence limits of saflufenacil and adjusted coefficient of determination ( $R^2$ ) under saturation and field capacity soil conditions. <sup>a</sup> .....	93
Table 15. Physical-chemical characteristics of soil samples selected to conduct the studies. <sup>a</sup> .....	104
Table 16. Chemical structures, recommended field rate, estimated sample rate and solubility in water of pesticides selected to conduct the studies. ....	105
Table 17. Herbicides molecular weight (MW), optimizing parameters for detection and quantification, and retention time during the UPLC/MS/MS analysis. ...	108

## CHAPTER I

### INTRODUCTION

Saflufenacil [*N'*-[2-chloro-4-fluoro-5-(3-methyl-2,6-dioxo-4-(trifluoromethyl)-3,6-dihydro-1(2*H*)-pyrimidinyl)benzoyl]-*N*-isopropyl-*N*-methylsulfamide] is a broadleaf herbicide registered in the United States during 2010 for preplant burndown and preemergence (PRE) applications in several crops. This new molecule is the active ingredient in the Kixor<sup>®</sup> Herbicide Technology which resulted in labeling of four commercial products by BASF. In one of the products with a trade name of Sharpen<sup>®</sup>, burndown application is reported to have herbicidal activity in 66 broadleaf weed species by the action of saflufenacil, the only active ingredient contained in the formulated product.

The effectiveness of saflufenacil on broadleaf weed control could be explored in rice, especially in weed management programs where additional activity on dicotyledon weeds is needed. Clomazone and imazethapyr are widely utilized herbicides in rice providing excellent annual grass control. Occurrence of barnyardgrass resistant to propanil and quinclorac (Baltazar and Smith, 1994; Malik et al., 2010; Talbert and Burgos, 2007) has contributed to considerable use of clomazone for rice weed management. In the case of imazethapyr, development of imidazolinone-tolerant rice (Croughan et al., 1996) offering an opportunity for chemical control of red rice (Avila et

---

This dissertation follows the style of Crop Protection.



al., 2005b; Ottis et al., 2004; Steele et al., 2002), resulted in faster adoption of this herbicide across red rice infested areas (Burgos et al., 2008). Although, clomazone and imazethapyr provide excellent control of grasses with the recommended rates for rice, they are ineffective on broadleaf species such as hemp sesbania (Scott et al., 2006; Talbert and Burgos, 2007), and complementary treatment needs to be implemented for control of dicotyledon weeds.

Development of saflufenacil for rice could generate a new tool for farmers providing a comprehensive weed control program with established herbicides. However, crop tolerance, efficacy and herbicide interactions would need to be investigated before saflufenacil can be used for controlling weeds in rice. Research conducted recently has demonstrated that saflufenacil can be safely used in PRE applications with several winter and summer crops (Knezevic et al., 2010; Sikkema et al., 2008; Soltani et al., 2009; Soltani et al., 2010) justifying PRE approval in multiple crops. However, in rice saflufenacil is currently recommended only for preplant burndown applications after approval of a supplemental label for Sharpen<sup>®</sup> in 2011 (CDMS, 2011). Postemergence (POST) application of saflufenacil is currently not recommended in any row crop. However, tank-mix combinations of saflufenacil with imazethapyr would require the use of POST applications due to the imazethapyr recommendations. Hence, experimentation with applications of saflufenacil at different growth stages would be required to indicate the rice response to PRE and POST treatments and the feasibility for its use in rice.

Saflufenacil is a member of the pyrimidinedione family of herbicides, which inhibits the protoporphyrinogen oxidase (PPO or Protox) enzyme (Grossmann et al.,

2010). PPO leads the conversion of protoporphyrinogen IX (PPGIX) to protoporphyrin IX (PPIX) in the chlorophyll and heme biosynthesis pathway (Hess, 2000; Duke et al., 1991; Senseman, 2007). Inhibition of PPO results in transitional accumulation of PPGIX in the chloroplast until it diffuses into the cytoplasm (Lehnen et al., 1990). Outside of its normal site, PPGIX is converted to PPIX by herbicide insensitive enzymes (Jacobs and Jacobs, 1993; Jacobs et al., 1991; Lee et al., 1993). Subsequently, PPIX which is the first light-absorbing chlorophyll precursor, reacts with light and oxygen to generate singlet oxygen causing lipid peroxidation (Hess, 2000; Senseman, 2007). Hence, membrane leakage occurs resulting in rapid disintegration of cells and cell organelles (Duke et al., 1991). Therefore, PPO inhibiting compounds such as saflufenacil are fast-acting, light-dependent herbicides that result in wilting and necrosis symptoms on vulnerable plant species (Grossmann et al., 2010).

Because saflufenacil action takes place rapidly causing loss of membrane integrity, it could reduce the effectiveness of other herbicides such as imazethapyr when used in tank-mixed applications. Synergism, antagonism, or no interaction of tank-mixed application of PPO inhibitors had been reported and results were dependent on weed species, herbicide tested, and rates applied (Beyers et al., 2002; Unland et al., 1999; Wesley and Shaw, 1992). Uptake and herbicide movement are frequently identified as the primary causes of herbicide interactions (Ashigh and Hall, 2010; Eubank et al., 2010; Frihauf et al., 2010a; Moran et al., 2011; Unland et al., 1999). Therefore, absorption and translocation should be investigated to elucidate potential effects of saflufenacil on action of imazethapyr in red rice.

Besides the agronomic attributes, studies need to be conducted to further understand herbicide fate and behavior in rice soils. Rice production differentiates from other major crops, as plants can be cultivated under flooding conditions (Das and Uchimiya, 2002). Currently, no work has been published in scientific journals investigating degradation and persistence of saflufenacil in soils, especially considering the flooded conditions similar to those found in an irrigated rice field. Degradation is one of the key processes affecting a pesticide's environmental impact (Villaverde et al., 2008). Therefore, information regarding saflufenacil degradation in soils from different geographic regions can support more effective agronomic and environmental management practices.

Additionally, this research is investigating soil adsorption of herbicides including saflufenacil using reference compounds and automated techniques such accelerated solvent extraction (ASE) for better estimation and interpretation of pesticide sorption in soil dynamics. The accurate comparison of adsorption values ( $K_d$ ) published by the scientific community remains unattainable (Kah and Brown, 2007; Yazgan et al., 2005) after more than forty years of its development (Talbert and Fletchall, 1965) as adsorption values are potentially affected by the methodological procedures (Farmer and Aochi, 1974; Kah and Brown, 2007; Koskinen and Cheng, 1983; Yazgan et al., 2005). Therefore, methodology was proposed to study  $K_d$  values of specific molecules simultaneously with pesticides of relatively weak and strong adsorptivity in soil. This model can generate alternatives for more accurate estimation of soil adsorption values for different chemical classes. Besides, the novel methodology can create options for

comparison between and among studies and improve  $K_d$  values use and interpretation in regulation policies and environmental fate models.

Considering the aspects previously discussed the goals of this research were to:

1) evaluate rice tolerance to saflufenacil applied PRE and POST and the combination of saflufenacil and clomazone in light-textured soils; 2) investigate rice tolerance and weed control (red rice and hemp sesbania) by application of saflufenacil tank-mixed with imazethapyr; 3) evaluate the absorption and translocation of saflufenacil in hemp sesbania and imazethapyr in red rice as a function of their postemergence interaction and light intensity; 4) assess saflufenacil degradation and persistence as well as microbial activity in soils from different rice regions under field capacity (non-flooded) and saturated (flooded) conditions; and 5) investigate the use of reference compounds that represent minimum and maximum  $K_d$  values during the determination of pesticide adsorption with different methodologies. Experiments designed to achieve each specific objective will be described in the following chapters.

**CHAPTER II**  
**RICE TOLERANCE TO SAFLUFENACIL IN CLOMAZONE WEED CONTROL**  
**PROGRAM\***

**INTRODUCTION**

Rice is a staple food in numerous countries around the world. Rice consumption provides more calories than any other single food (Kennedy, 2002), serving daily as a source of carbohydrate, proteins, lipids, vitamins, and minerals (Lin et al., 2009; Walter et al., 2008). Rice yield is on an upward path to achieve higher worldwide production as indicated by data compiled in the last ten years by the Food and Agriculture Organization (FAO). Production increased from 599 million tons in 2000 to 685 million tons in 2009 (FAO, 2011). However, current supply trends are considered insufficient to track projected demand as the world population continues to rise (Aureus and Reyes, 2011). Crop management will be even more important in production areas in order to maintain and/or expand rice production.

In the United States, 1.07 million hectares were harvested resulting in the production of 8.5 million tons of rice in the crop season of 2011 (USDA, 2011). The southern states of Arkansas, California, Louisiana, Mississippi, Texas and Missouri primarily contributed to this production. As weeds are one of the most important

---

\*Reprinted with permission from “Rice tolerance to saflufenacil in clomazone weed control program” by Camargo, E.R., Senseman, S.A., McCauley, G.N., Guice, J.B., 2011. *Int. J. Agron.* doi:10.1155/2011/402461.

biological factors limiting rice production (Saito, 2010), weed management is crucial to maximize rice yield potential. Several annual grasses and broadleaf species are considered troublesome weeds in United States rice regions (Webster, 2000). In Arkansas, the largest-producing state, barnyardgrass (*Echinochloa crus-galli*) was reported to be the most problematic grassy weed (Norsworthy et al., 2007). In the same survey, clomazone was described to be the most regularly recommended PRE herbicide. Clomazone is a relatively recent herbicide in rice, with commercialization occurring at the beginning of the century (Mitchell and Gage, 1999; Talbert and Burgos, 2007). This herbicide is metabolized to the 5-keto form of clomazone. The 5-keto form, which is the active herbicide, inhibits 1-deoxy-D-xyulose 5-phosphate synthase, a key component to plastid isoprenoid synthesis (Senseman, 2007). Symptomology of clomazone includes bleaching that can progress to necrosis (Scherder et al., 2004; Senseman, 2007).

Weed management programs with clomazone are widely utilized because of the low cost and effective annual grass control (Willingham et al., 2008). Problematic species such as barnyardgrass and broadleaf signalgrass (*Urochloa platyphylla*) can be effectively controlled by clomazone (Webster et al., 1999; Willingham et al., 2008). Also, occurrence of barnyardgrass resistant to propanil and quinclorac (Baltazar and Smith, 1994; Malik et al., 2010; Talbert and Burgos, 2007) has contributed to considerable use of clomazone for weed management in rice. Although, clomazone provides excellent control of grasses with the recommended rates for rice, it is weak on broadleaf and sedge species (Talbert and Burgos, 2007).

Saflufenacil is a new herbicide currently registered for burndown and PRE applications in winter cereals, soybean, corn and other crops (Sikkema et al., 2008; Soltani et al., 2009; Soltani et al., 2010). This herbicide is highly effective on dicotyledon weeds with both residual and contact activity (Geier et al., 2009; Liebl et al., 2008). Consequently, saflufenacil could broaden the weed control spectrum in a clomazone program by providing broadleaf control. Improvement in broadleaf weed control was indicated as a priority topic of research by survey conducted in Arkansas (Norsworthy et al., 2007). Development of saflufenacil for rice could generate a new tool to help farmers with some of the specific broadleaf weed control problems. However, crop tolerance and herbicide interactions need to be evaluated before saflufenacil can be used for weed control in rice.

Saflufenacil is a member of the pyrimidinedione chemical class of herbicides, which inhibit the PPO enzyme (Grossmann et al., 2010). Crop response to saflufenacil has been studied for PRE applications in proso millet (Lyon and Kniss, 2010) and leguminous crops (Soltani et al., 2010), for POST applications in winter wheat (Frihauf et al., 2010b; Frihauf et al., 2010c), and for PRE and POST applications in corn (Soltani et al., 2009), wheat, barley and oats (Knezevic et al., 2010; Sikkema et al., 2008), but currently no work has been published regarding rice tolerance to this herbicide. Saflufenacil can provide broadleaf weed control when applied PRE or POST as Geier et al. (2009) determined in a greenhouse study with five weed species. Although control can be achieved with PRE and POST applications, crop injury may be a limiting factor to use saflufenacil in a weed control program with clomazone.

PRE tank-mixed application may cause higher rice injury especially in light-textured soils. Saflufenacil has been demonstrated to be safe in PRE applications for several grass crops such as corn, wheat, barley and oats (Knezevic et al., 2010; Sikkema et al., 2008; Soltani et al., 2009), however rice response has not been investigated in light-textured soils. The clomazone label excluded its applications in coarse soils, but results obtained by Willingham et al. (2008) indicated that it could be used without causing significant injury. Therefore, crop response to combinations of clomazone and saflufenacil in light-textured soils could indicate potential for use of these herbicides in a rice weed control program.

POST application of saflufenacil is not currently recommended for in-crop weed control. Unacceptable injury and yield reduction in barley, oats and wheat were observed for POST applications of this material (Sikkema et al., 2008). In corn, application of saflufenacil without adjuvant at spike (coleoptile has reached the soil surface) and 2- to 3-leaf stages resulted in acceptable tolerance; however, when adjuvant was included with the herbicide, crop injury increased resulting in yield loss (Soltani et al., 2009). Moreover, recent results in winter wheat, indicated saflufenacil potential for POST applications when used in combination with 2,4-D amine without non-ionic surfactant (Frihauf et al., 2010b; Frihauf et al., 2010c). Also, a water-dispersible granule formulation provided minimal injury in POST applications (Frihauf et al., 2010c).

Hence, experimentation with applications of saflufenacil is needed to evaluate the rice response to PRE and POST treatments. Depending on crop tolerance, saflufenacil used in combination with clomazone could result in an alternative tool for



rice farmers providing a comprehensive weed control program. Therefore, the objective of this research was to evaluate 1) rice tolerance to saflufenacil applied alone PRE and POST and 2) the combination of saflufenacil and clomazone in light-textured soils.

## **MATERIAL AND METHODS**

Two separate experiments (PRE and POST saflufenacil) were conducted during 2009 and 2010 at the Texas A&M AgriLife Research and Extension Center located at Eagle Lake, TX. The soil was a Nada fine sandy loam (fine-loamy, siliceous, active, hyperthermic Albaquic Hapludalfs) with 56.8% of sand, 33.6% of silt, 9.6% of clay, 0.8% of organic carbon, and pH of 6.5. The area used to conduct the research was in a rice-fallow rotation where rice was seeded every three years. Therefore, studies were conducted in different fields within the research station each year. Soil was disked to reduce vegetative biomass during the summer preceding establishment of experiments. Prior to crop seeding in the spring, the seedbed was cultivated again and the soil surface was graded to guarantee adequate field slope.

The experiments were drill-seeded on April 15<sup>th</sup>, 2009, and March 31<sup>st</sup>, 2010 using the cultivar 'Cocodrie' at the rate of 80 kg ha<sup>-1</sup>. Emergence of rice occurred 11 days after seeding (DAS) the experiments in 2009 and 8 DAS in 2010. In both years, plots were formed by seven rows spaced at 19 cm from each other (1.3 m wide) and measuring 4.9 m long. Plots were separate from each other by a 0.3-m alley. Before establishing season-long flood, rice fields were submerged and subsequently drained at least twice to introduce moisture in the soil. Season-long flood was initiated 25 days

after rice emergence (DAE) in 2009 and 35 DAE in 2010. Triple superphosphate, potassium chloride and urea were applied and incorporated in the soil prior to seeding at a rate of 53 kg ha<sup>-1</sup> of P<sub>2</sub>O<sub>5</sub>, K<sub>2</sub>O, and N, respectively. Mid-season nitrogen fertilization was conducted at pre-flooding using 79 kg ha<sup>-1</sup> of nitrogen in the form of urea followed by 89 kg ha<sup>-1</sup> at panicle differentiation in the form of ammonium sulfate.

The experimental design was a randomized complete block with a factorial arrangement. The treatments included combinations of three rates of clomazone (0, 392, and 505 g ha<sup>-1</sup>, Command<sup>®</sup> 3 ME, microencapsulated formulation, FMC Corporation, Philadelphia, PA) and five rates of saflufenacil (Sharpen<sup>®</sup>, suspension concentrate formulation, BASF Corporation, Research Triangle Park, NC). In the experiment with PRE applications of saflufenacil rates were 0, 25, 50, 100, and 200 g ha<sup>-1</sup>. Rates for POST applications of saflufenacil were 0, 12.5, 18.75, 25, and 50 g ha<sup>-1</sup>. Treatments were replicated four times. Clomazone treatments were applied immediately after rice seeding in both experiments. Clomazone and saflufenacil rates were tank-mixed in the experiment with PRE applications. In the study with POST applications of saflufenacil, treatments were applied at the 4- to 6-leaf stage (V4-V6, according to Counce et al., 2000). Methylated seed oil (Methylated spray oil<sup>®</sup>, blend of distilled methyl esters and nonionic surfactants, Helena Chemical Company, Collierville, TN) at 1% v/v was included in POST applications.

Clomazone treatments provided effective control of grassy weeds. Consequently, treatments that did not receive clomazone application were maintained grass-free by applying propanil plus quinclorac. In 2009, propanil (4485 g ha<sup>-1</sup>) and quinclorac (560 g

ha<sup>-1</sup>) were applied at the 4- to 6-leaf stage of rice (V4-V6) due to rainfall events that delayed earlier placement of these herbicides. In 2010, application was conducted at 2-leaf stage (V2) using 3364 g ha<sup>-1</sup> of propanil and 560 g ha<sup>-1</sup> of quinclorac. Treatment applications were performed using a boom equipped with three flat-fan nozzles (Teejet XR11002, Spraying Systems Co., Wheaton, IL) spaced 50 cm apart. The boom was coupled to a CO<sub>2</sub>-pressurized backpack sprayer calibrated to deliver 140 L ha<sup>-1</sup> of spray solution at 172 kPa. The day before establishment of the season-long flood, maintenance applications were performed in all plots using a tractor sprayer. In 2009, halosulfuron-methyl (67 g ha<sup>-1</sup>) plus zeta-cypermethrin (28 g ha<sup>-1</sup>) were used to control sedges and insects, respectively. Only the insecticide zeta-cypermethrin (28 g ha<sup>-1</sup>) was sprayed in 2010.

Rice injury was estimated visually using a scale of 0 to 100%, where 0 = no rice injury and 100 = rice death. Visual assessments were conducted at 10, 22, 32 and 38 DAE for PRE application of saflufenacil. In 2010, the first evaluation was conducted at 15 DAE instead of 10 DAE. Therefore, data collected at 10 and 15 DAE were used for statistical analysis of combined years. In the experiments with POST treatment of saflufenacil, injury was reported at 3, 8, 18 and 24 days after saflufenacil application (DAA) in 2009 and at 6, 12, 19 and 24 DAA in 2010. For statistical analysis of combined years, data were paired according to the assessment order of each year. Therefore, results from 3 and 6 DAA were considered the first evaluation, as well as the data from 8 and 12 DAA were used for the second evaluation. This approach was followed until the last injury rating. Rice heading was determined to be the day in which

more than 50% of the plants had the panicle emerged from the leaf sheath (Counce et al., 2000). Rice fields were drained before harvesting at 100 DAE in 2009 and 110 DAE in 2010. Four plot rows were harvested with a mechanical harvester when grain moisture was approximately 20%. Harvested samples were weighed and a moisture meter was used to determine the moisture content of individual samples. Final grain yield was adjusted to 12% moisture and converted to  $\text{kg ha}^{-1}$ . Subsequently, a sub-sample was removed, dried and used to determine milling yield. Dried samples were processed using a rice-milling machine (Zaccaria rice-testing, model PAZ/1-DTA, Indústria Machina Zaccaria S/A, Limeira, São Paulo, Brazil).

All data were subjected to analysis of variance (ANOVA) using the PROC MIXED procedure of SAS (SAS<sup>®</sup> 9.2 Software, SAS Institute Inc., Cary, NC). Crop injury data were subjected to arcsine square-root transformation prior to analysis. Subsequently, homogeneity and normality of variance were verified using Bartlett's and Shapiro-Wilk's Test. Data were combined within years, therefore variances were partitioned into random effects (years, blocks within years and years by treatment interactions) and fixed effects (clomazone rates, saflufenacil rates and their interactions). Results were combined when interaction of years by treatments were not significant. Means for significant effects were separated using Tukey's Test ( $p \leq 0.05$ ).

## RESULTS AND DISCUSSION

### Rice injury from saflufenacil applied preemergence

Saflufenacil rate by clomazone rate by year interaction was demonstrated by ANOVA at the first (10/15 DAE) and second (22 DAE) assessments in the study with PRE applications of saflufenacil (Table 1). Consequently, results were presented for each year separately. In 2009, no interaction between clomazone and saflufenacil rates was observed at 10 and 22 DAE. No injury from PRE application of saflufenacil alone was observed in 2009 (Table 2). Injury increased following rate increments of clomazone, but it did not surpass 11% for data collected at 10 DAE. Clomazone applied at 392 g ha<sup>-1</sup> can be used as a reference rate since it provided effective weed control while being safe to rice in sandy soils (Willingham et al., 2008). Injury from clomazone diminished over time with less than 3% observed at the later evaluation (22 DAE).

In 2010, no clomazone by saflufenacil interaction was detected in the first assessment (15 DAE). A similar trend for clomazone injury was observed in 2010 when compared with the first assessment of 2009, but higher values (up to 31%) were reported in the second year. Relatively higher clomazone injury may be related with plants exposure to lower temperatures in the beginning of the growing season due to an earlier planting date in 2010. For saflufenacil rates, greater injury was observed at the highest rate (200 g ha<sup>-1</sup>) when compared with the lower rates (25 to 100 g ha<sup>-1</sup>). However, injury observed at 200 g ha<sup>-1</sup> was not different than the plots untreated with saflufenacil. These results are associated with variability of clomazone when data were averaged across saflufenacil rates.

**Table 1.** *P* values for multiple assessments of visible injury, yield and whole grain for preemergence (PRE) and postemergence (POST) applications of saflufenacil.

Study	Source of variation	Pr > F for analyzed parameters					
		Visible injury <sup>a</sup>				Yield	Whole grain
		1 <sup>st</sup>	2 <sup>nd</sup>	3 <sup>rd</sup>	4 <sup>th</sup>		
PRE	Year (Y)	<0.0001	<0.0001	<0.0001	<0.0001	<0.0001	<0.0001
	Block (year)	<0.0001	0.040	0.072	0.979	0.701	0.771
	Clomazone (C)	<0.0001	<0.0001	<0.0001	0.007	0.025	0.772
	C*Y	<0.0001	<0.0001	<0.0001	0.007	0.641	0.0008
	Saflufenacil (S)	0.001	<0.0001	0.128	<0.0001	0.151	0.699
	S*Y	0.198	0.0003	0.015	<0.0001	0.912	0.669
	C*S	0.495	0.163	0.458	0.109	0.450	0.971
	C*S*Y	0.047	0.020	0.764	0.109	0.809	0.614
POST	Year (Y)	<0.0001	<0.0001	<0.0001	<0.0001	<0.0001	<0.0001
	Block (year)	0.016	0.193	<0.0001	0.0135	0.020	0.0003
	Clomazone (C)	<0.0001	<0.0001	0.589	0.329	0.012	0.029
	C*Y	0.017	0.026	0.589	0.329	0.050	0.029
	Saflufenacil (S)	<0.0001	<0.0001	<0.0001	<0.0001	0.272	0.7475
	S*Y	<0.0001	<0.0001	<0.0001	<0.0001	0.659	0.804
	C*S	<0.0001	<0.0001	0.0008	0.0037	0.634	0.274
	C*S*Y	<0.0001	<0.0001	0.0008	0.0037	0.973	0.956

<sup>a</sup> Represents the 1<sup>st</sup>, 2<sup>nd</sup>, 3<sup>rd</sup> and 4<sup>th</sup> assessment evaluations for visible injury.

**Table 2.** Rice (*Oryza sativa* L.) visible injury at 10 days after emergence (DAE) and 22 DAE in 2009 and 15 DAE in 2010 in response to saflufenacil and clomazone applied preemergence. Saflufenacil results were averaged across clomazone rates and clomazone results were averaged across saflufenacil rates.

Saflufenacil rates (g ha <sup>-1</sup> )	Visual injury <sup>a</sup>		
	2009		2010
	10 DAE	22 DAE	15 DAE
	-----%-----		
0	5 <sup>b</sup>	2 <sup>b</sup>	21 ab <sup>c</sup>
25	4	1	17 b
50	6	2	16 b
100	6	2	16 b
200	9	3	23 a
Clomazone rates			
(g ha <sup>-1</sup> )			
0 <sup>d</sup>	0 c	2 ab	1 c
392	8 b	1 b	24 b
505	11 a	3 a	31 a

<sup>a</sup>Injury was estimated visually using a scale of 0 to 100% where 0 = no rice injury and 100 = rice death. <sup>b</sup>Means were not different according to F test at  $p \leq 0.05$ . <sup>c</sup>Means followed by a different letter are significantly different according to the Tukey's test ( $p \leq 0.05$ ). <sup>d</sup>Plots that did not receive clomazone were treated with propanil plus quinclorac.

A significant clomazone and saflufenacil rate interaction occurred for the second evaluation of 2010 (22 DAE). Injury was significantly different for saflufenacil

treatments at 100 and 200 g ha<sup>-1</sup>, however it was < 6% (Table 3). Necrotic tissue was visible in the lower region of the plant stem when saflufenacil was applied alone. In the treatments with PRE combinations of clomazone and saflufenacil greater injury was observed when the highest rates of the two herbicides were tank-mixed. Injury among saflufenacil rates ranged from 10 to 23% at 392 g ha<sup>-1</sup> of clomazone and from 20 to 40 at 505 g ha<sup>-1</sup> of clomazone.

**Table 3.** Rice (*Oryza sativa* L.) visible injury at 22 DAE in response to saflufenacil and clomazone applied preemergence. Data represent an interaction between rates of saflufenacil and clomazone in 2010.

Saflufenacil rates (g ha <sup>-1</sup> )	Visual injury <sup>a</sup>		
	Clomazone rates (g ha <sup>-1</sup> )		
	0 <sup>b</sup>	392	505
	-----%-----		
0	0 c <sup>c</sup>	15 bc	25 ab
25	0 c	15 bc	20 b
50	0 c	10 c	20 b
100	4 b	18 ab	20 b
200	6 a	23 a	40 a

<sup>a</sup>Injury was estimated visually using a scale of 0 to 100% where 0 = no rice injury and 100 = rice death. <sup>b</sup>Plots that did not receive clomazone were treated with propanil plus quinclorac. <sup>c</sup>Means followed by a different letter within a column are significantly different according to the Tukey's test ( $p \leq 0.05$ ).



At the intermediate rate of clomazone ( $392 \text{ g ha}^{-1}$ ), no differences were detected from 0 up to  $100 \text{ g ha}^{-1}$  of saflufenacil, demonstrating potential for use of these two herbicides. For the highest rate of clomazone, the treatment with no application of saflufenacil had statistically similar injury compared with the highest rate of saflufenacil. Variability within the highest rate of clomazone may explain these results. Clomazone plus saflufenacil applied PRE resulted in typical foliar bleaching followed by necrosis. Additionally, necrosis of the lower region of the stem was caused by the inhibition of the PPO enzyme by saflufenacil (Figure 1C).

Although injury was observed at the highest rates of saflufenacil applied PRE as well as when it was combined with clomazone in 2010, rice plants were able to recover over time. In later evaluations, data averaged across years and clomazone rates demonstrated less than 3% and 2% injury at 32 and 38 DAE, respectively (data not shown). Rice was consistently tolerant to PRE applications of saflufenacil alone up to  $200 \text{ g ha}^{-1}$  in both years of study.

Other summer and winter grass crops demonstrated the potential of saflufenacil for PRE applications. Summer crops such as corn tolerated up to  $200 \text{ g ha}^{-1}$  of saflufenacil applied PRE (Soltani et al., 2009). In proso millet, PRE application of 50 and  $100 \text{ g ha}^{-1}$  of saflufenacil reduced plant stand comparatively with the untreated check, however rates did not cause a yield reduction (Lyon and Kniss, 2010). Winter cereals such as wheat, barley and oats demonstrated crop tolerance to saflufenacil up to  $100 \text{ g ha}^{-1}$  (Sikkema et al., 2008). In a study conducted by Knezevic et al. (2010), saflufenacil rates up to  $400 \text{ g ha}^{-1}$  did not cause injury or yield reduction in winter wheat.

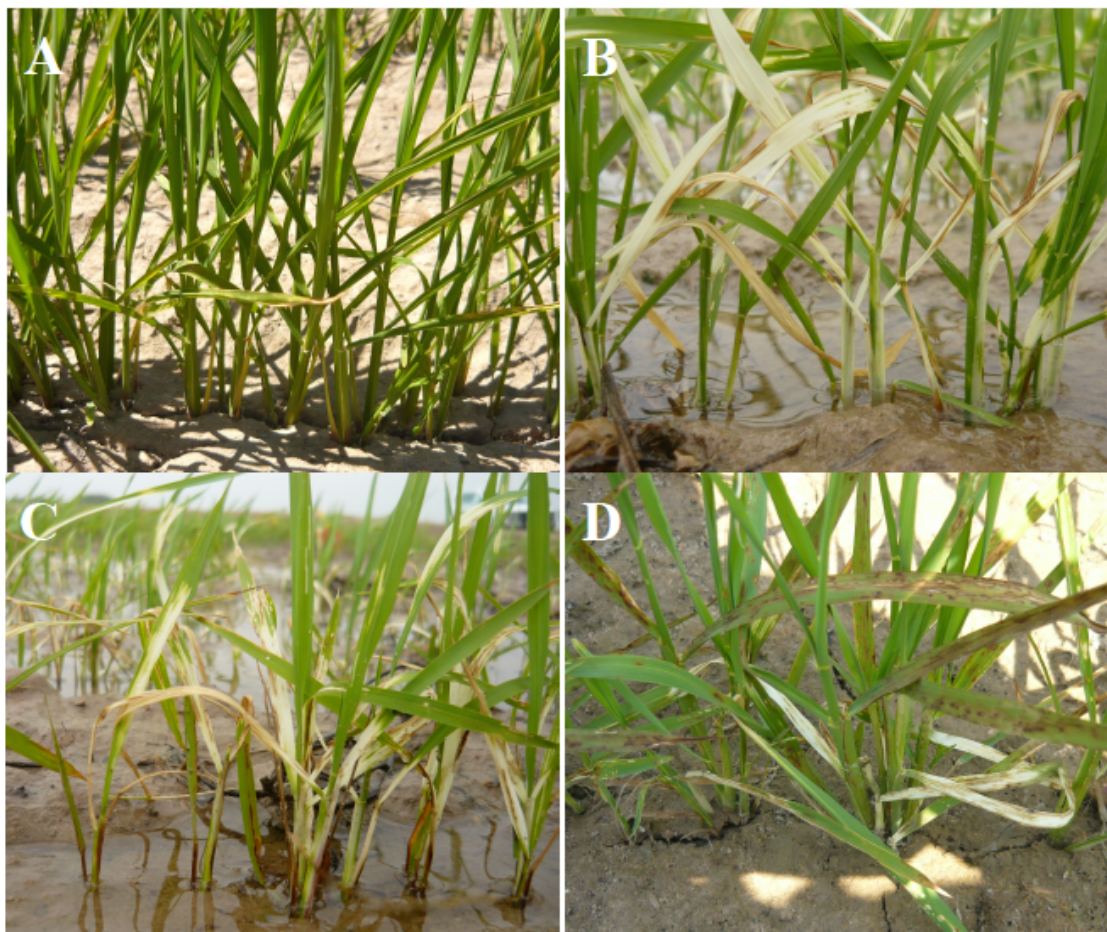

**Figure 1.** Rice symptoms from clomazone alone (B) and clomazone plus saflufenacil applied preemergence (C) and postemergence (D). Untreated check is represented in box A. Pictures were taken in different rice stages.

**Table 4.** Visible rice (*Oryza sativa* L.) injury at 3, 8, 18 and 24 days after application (DAA) in response to postemergence application (4- to 6-leaf stage, V4-V6) of saflufenacil following preemergence application of clomazone. Data represents an interaction between rates of saflufenacil and clomazone for experiment conducted in 2009.

Saflufenacil rates (g ha <sup>-1</sup> )	Visual injury <sup>a</sup>											
	3 DAA			8 DAA			18 DAA			24 DAA		
	Clomazone rates (g ha <sup>-1</sup> )			Clomazone rates (g ha <sup>-1</sup> )			Clomazone rates (g ha <sup>-1</sup> )			Clomazone rates (g ha <sup>-1</sup> )		
	0 <sup>b</sup>	392	505	0	392	505	0	392	505	0	392	505
	-----%-----											
0	5 b <sup>c</sup>	1 d	3 d	4 b	0 c	1 d	0 <sup>d</sup>	0 b	0 b	0 <sup>d</sup>	0 b	0 c
12.5	11 ab	11 c	13 c	10 ab	6 b	8 c	0	0 b	0 b	0	1 b	0 c
18.75	13 ab	25 b	16 c	8 ab	15 b	11 c	6	3 b	0 b	4	5 a	1 bc
25	13 ab	24 bc	35 b	10 ab	15 b	25 b	6	3 b	4 a	4	1 b	5 ab
50	18 a	50 a	68 a	15 a	43 a	46 a	4	14 a	11 a	3	9 a	8 a

<sup>a</sup>Injury was estimated visually using a scale of 0 to 100% where 0 = no rice injury and 100 = rice death. <sup>b</sup>Plots that did not receive clomazone were treated with propanil plus quinclorac. <sup>c</sup>Means followed by a different letter within a column are significantly different according to the Tukey's test (p≤0.05). <sup>d</sup>Means were not different according to F test at p≤0.05.

In rice, saflufenacil seems to be a potentially useful and safe herbicide for PRE application with clomazone.

### **Rice injury from saflufenacil applied postemergence**

In the study with POST application of saflufenacil, interaction among years, clomazone, and saflufenacil rates was verified by ANOVA for all evaluations, resulting in analysis of data by individual years. In 2009, interaction between rates of saflufenacil and clomazone were observed throughout all assessment timings. Rice injury was observed to be higher with combinations of the highest rate of saflufenacil ( $50 \text{ g ha}^{-1}$ ) and clomazone treatments (Table 4). In evaluations conducted 3 days after POST application (DAA) injury as high as 68% was observed with the combination of  $505 \text{ g ha}^{-1}$  of clomazone and  $50 \text{ g ha}^{-1}$  of saflufenacil. The mode of action of these herbicides may explain the interaction observed where initial injury from clomazone could deplete the carotenoid pool leading to a more intense action from the radicals produced by inhibition of PPO (saflufenacil). POST application of saflufenacil after spraying clomazone PRE resulted in necrosis on the upper leaves of the rice plants by action of saflufenacil. At the same time, lower leaves were still displaying bleaching symptoms from clomazone (Figure 1D).

Rice injury intensified with increasing rates of saflufenacil alone, reaching up to 18% in the initial rating of 2009. Application of propanil ( $4485 \text{ g ha}^{-1}$ ) and quinclorac ( $560 \text{ g ha}^{-1}$ ) to control grass weeds in plots that did not receive clomazone caused 5% injury even in the treatment without saflufenacil POST application. Combinations of the

intermediate rate of clomazone ( $392 \text{ g ha}^{-1}$ ) and rates of saflufenacil up to  $25 \text{ g ha}^{-1}$  applied POST resulted in 25% injury. The initial injury observed from POST application of saflufenacil alone or following a PRE application of clomazone could be acceptable as long as rice plants recover and rice yield would be not negatively affected by early phytotoxicity.

In evaluations conducted at 8 DAA, rice response to herbicide treatments followed a similar trend as initial evaluation, but overall intensity of injury had already diminished over a 5-day interval. In subsequent evaluations, rice injury decreased significantly to  $< 14\%$  and  $< 9\%$  for all treatments during assessments performed 2 and 3 weeks after initial evaluation. No significant differences were observed among saflufenacil treatments alone at later ratings. In 2009, nitrogen application and season-long flood were introduced in the experimental area at 10 DAA. These management practices likely helped the injured rice overcome herbicide symptoms more rapidly.

No interaction between clomazone and saflufenacil was verified in 2010. In the evaluation at 6 DAA, injury from saflufenacil averaged across clomazone rates was as high as 26% at  $50 \text{ g ha}^{-1}$  of saflufenacil, but  $< 13\%$  in the remaining saflufenacil treatments (Table 5). In the subsequent evaluation conducted at 12 DAA, significantly greater injury was detected at the highest rate of saflufenacil (9%). However no differences were observed from 0 to  $25 \text{ g ha}^{-1}$  of saflufenacil. Injury was absent in all plots for evaluations conducted at 19 and 24 DAA.

POST application of saflufenacil is not currently recommended in row crops. Work by others demonstrated injury as high as 76% in winter cereals from POST

**Table 5.** Rice (*Oryza sativa* L.) visible injury at 6 and 12 days after application (DAA) in response to postemergence application (4- to 6-leaf stage, V4-V6) of saflufenacil following preemergence application of clomazone. Saflufenacil results were averaged across clomazone rates and clomazone results were averaged across saflufenacil rates.

Saflufenacil rates (g ha <sup>-1</sup> )	Visual injury <sup>a</sup>	
	2010	
	6 DAA	12 DAA
	-----%-----	
0	3 d <sup>b</sup>	0 b
12.5	6 c	0 b
18.75	9 bc	1 b
25	13 b	2 b
50	26 a	9 a
Clomazone rates (g ha <sup>-1</sup> )		
0 <sup>c</sup>	9 b	2 <sup>d</sup>
392	9 b	2
505	17 a	3

<sup>a</sup>Injury was estimated visually using a scale of 0 to 100% where 0 = no rice injury and 100 = rice death. <sup>b</sup>Means followed by a different letter are significantly different according to the Tukey's test ( $p \leq 0.05$ ). <sup>c</sup>Plots that did not received clomazone were treated with propanil plus quinclorac. <sup>d</sup>Means were not different according to F test at  $p \leq 0.05$ .

application of saflufenacil remaining as high as 35% almost one month after treatment (Sikkema et al., 2008). Corn demonstrated acceptable tolerance to saflufenacil applied

without adjuvant at spike and 2- to 3- leaf stages, however addition of adjuvant increased injury and caused yield loss, especially when applications were made at the 2- to 3-leaf stage (Soltani et al., 2009). More recently, results obtained in winter wheat indicated lower injury from POST applications of saflufenacil in combination with 2,4-D amine without non-ionic surfactant when compared with saflufenacil alone (Frihauf et al., 2010b). In this study, injury occurred with POST application of saflufenacil alone or in a weed control program with clomazone in light-textured soils, but rice plants seemed to recover from early phytotoxicity.

Saflufenacil applications made prior to and after emergence did not affect heading in either year. Therefore, rice development was not affected by crop injury observed early in the season from saflufenacil and clomazone treatments. Fifty percent heading was observed at 75 and 82 DAE in 2009 and 2010, respectively. This is in the normal range for a very early maturity cultivar such as “Cocodrie” (Way, 2010).

### **Grain yield and quality**

No interaction among herbicide treatments and years was revealed by ANOVA; therefore, results were combined over years. Also, no interaction among clomazone and saflufenacil was detected from pooled data during the 2-year study. Consequently, grain yield was presented according to saflufenacil rates. Rice yield was not significantly affected by saflufenacil PRE and POST applications (Figure 2). Grain yield ranged from 8.05 to 8.58 t ha<sup>-1</sup> among the PRE rates of saflufenacil. For the POST rates of saflufenacil, rice yield was between 7.78 to 8.21 t ha<sup>-1</sup>.

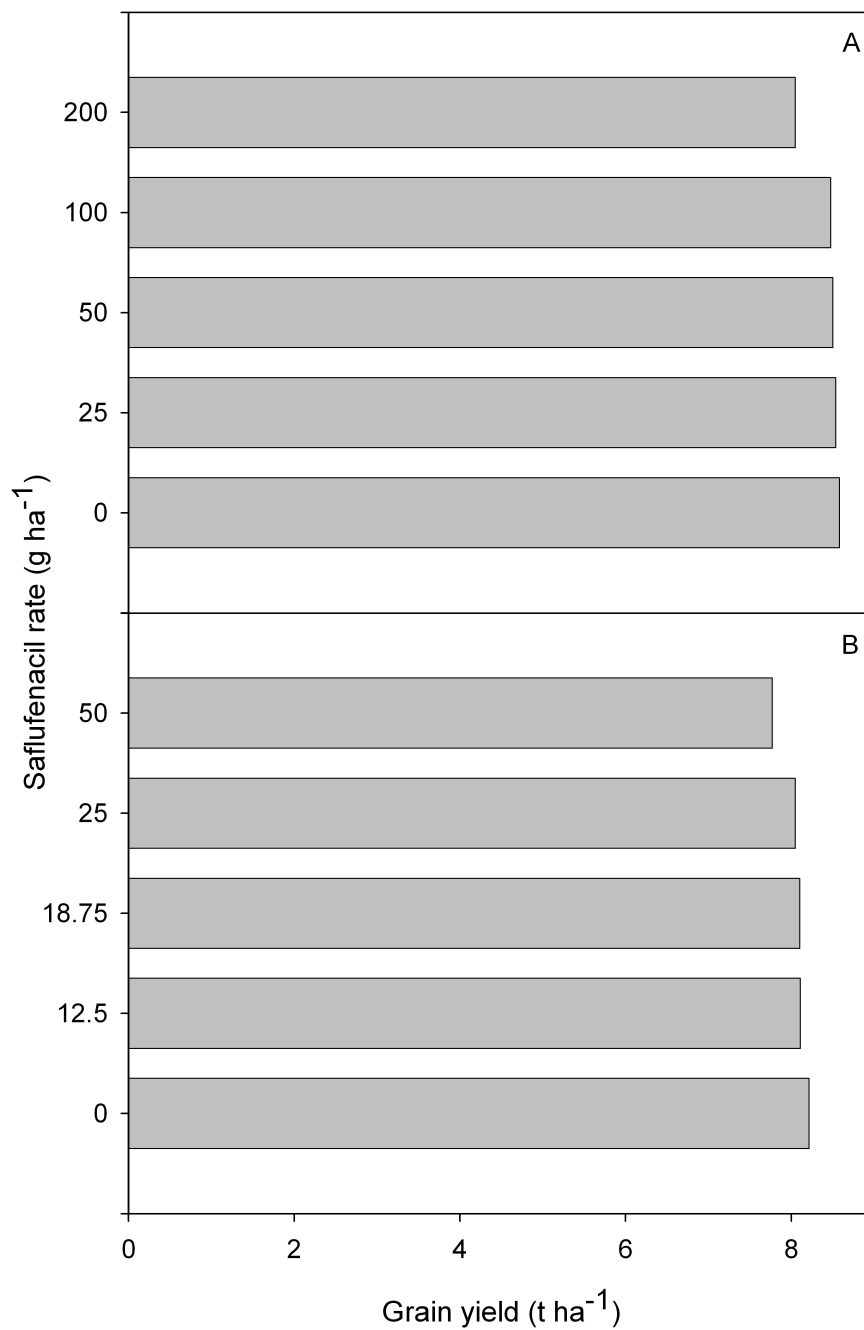

**Figure 2.** Grain yield ( $\text{t ha}^{-1}$ ) in response to preemergence (A) and postemergence (B) application of saflufenacil following preemergence application of clomazone. Data were averaged across clomazone rates. Means were not different according to F-test at  $p \leq 0.05$ .



Although injury of almost 70% occurred early in the season from combinations of clomazone PRE and saflufenacil POST applications, rice yield was not adversely affected in any saflufenacil treatment. Contradictory, injury from POST application of saflufenacil in corn (Soltani et al., 2009), barley, oats and wheat (Sikkema et al., 2008) and winter wheat (Knezevic et al., 2010) significantly reduced yield. Differences in intrinsic tolerance and crop management associated with rice production such as nitrogen fertilization followed by establishment of flooding may be favoring rice recovery from clomazone and saflufenacil injury.

Whole grain percentage was similar among saflufenacil rates in PRE and POST application studies. Whole grain yield was higher than 60% for all rates of saflufenacil applied PRE and POST in the average of two years of data (data not shown). This would be an expected result considering that no delay in heading was reported from herbicides treatments.

## **CONCLUSIONS**

In summary, rice was consistently tolerant to PRE applications of saflufenacil alone up to 200 g ha<sup>-1</sup> in both years of study. Combination of saflufenacil up to 100 g ha<sup>-1</sup> with an intermediate rate of clomazone (392 g ha<sup>-1</sup>) can be a potential mixture for PRE application in rice regarding crop tolerance. Greater injury occurred when saflufenacil was applied POST at 50 g ha<sup>-1</sup> following clomazone. However, saflufenacil rates up to 25 g ha<sup>-1</sup> applied POST following an intermediate rate of clomazone resulted in initial rice injury that rapidly diminished. Rice yield was not adversely affected by saflufenacil

rates applied either PRE or POST in a clomazone weed control program in light-textured soils.

### CHAPTER III

## RICE (*Oryza sativa* L.) RESPONSE AND WEED CONTROL FROM TANK-MIX APPLICATIONS OF SAFLUFENACIL AND IMAZETHAPYR\*

### INTRODUCTION

Worldwide rice production has increased every year during the last five years reaching 685 million tons in 2009 (FAO, 2011). Rice is a staple food in numerous countries around the globe serving daily as a source of carbohydrate, proteins, lipids, vitamins, and minerals (Walter et al., 2008). Therefore, rice production should maintain its trend in order to support the constantly growing consumption demand (Bennett, 2008). In the United States, rice production is concentrated in the southern states of Arkansas, California, Louisiana, Mississippi, Texas and Missouri. In production areas, weed management is crucial to maximize rice yield potential (Agostinetto et al., 2010; Smith, 1988).

Annual grasses and broadleaf species such as red rice (*Oryza sativa* L.) and hemp sesbania (*Sesbania exaltata* P. Mill.) are considered some of the most common and troublesome weed species where rice is grown (Webster, 2000). These species cause significant yield reduction by competing for water, light and nutrients. Red rice adversely affected rice tillering, leaf area index, and plant biomass resulting in yield

---

\*Reprinted with permission from “Rice (*Oryza sativa* L.) response and weed control from tank-mix applications of saflufenacil and imazethapyr” by Camargo. E.R., Senseman, S.A., McCauley, G.N., Guice, J.B., 2012. *Crop Prot.*, 31, 94-98. Copyright 2011 Elsevier Ltd.

reduction as high as 80% depending on weed population density and red rice ecotype (Estorninos et al., 2005). For hemp sesbania, a weed control program needs to be adopted for populations starting at only 1 to 2 plants m<sup>-2</sup> to avoid yield reduction (Smith, 1988). Additionally, grain quality of the harvested rice is reduced by competition and weed seed contamination (Menezes et al., 1997; Smith, 1988), which results in additional monetary loss to the rice producers.

Development of imidazolinone-tolerant rice offered an opportunity for chemical control of red rice (Croughan et al., 1996). In the United States, this technology became available in 2002 with the commercial release of imazethapyr herbicide and imazethapyr-tolerant cultivars. Imazethapyr, which reduces biosynthesis of branched chain amino acids isoleucine, leucine, and valine by inhibiting the enzyme acetolactate synthase (Senseman, 2007), constitutes an effective tool for controlling red rice (Avila et al., 2005b; Ottis et al., 2004; Steele et al., 2002). Therefore, imazethapyr rapidly became an important herbicide in red rice infested areas (Burgos et al., 2008). Although, imazethapyr provides excellent control of grassy weeds, it is ineffective on broadleaf species such as hemp sesbania (Scott et al., 2006), and a complementary treatment needs to be implemented for control of dicotyledon weeds.

Saflufenacil is a new herbicide from BASF for residual broadleaf weed control in corn and other crops (Sikkema et al., 2008; Soltani et al., 2009). This herbicide is highly effective on dicotyledon weeds with both residual and contact activity (Liebl et al., 2008). Consequently, saflufenacil effectiveness on broadleaf control could be explored in rice weed management programs especially in combination with imazethapyr and

other compounds where additional activity on dicotyledon weeds is needed. However, crop tolerance, efficacy and herbicide interactions would need to be evaluated before saflufenacil can be used as an effective tool for controlling weeds in rice.

In rice, tank-mix combinations of saflufenacil with imazethapyr would require the use of POST applications due to the imazethapyr recommendations. Sikkema et al. (2008) indicated that POST applications of saflufenacil caused unacceptable injury and yield reduction in barley, oats and wheat. Saflufenacil applied without adjuvant at spike and 2- to 3-leaf stages resulted in acceptable corn tolerance, however, crop injury increased considerably and yield loss was observed when adjuvant was included in the treatment (Soltani et al., 2009). Hence, experimentation with applications of saflufenacil at different growth stages would be required to indicate the rice response to POST treatments and the feasibility for its use in rice.

Saflufenacil is a member of the pyrimidinedione family of herbicides, which inhibit the PPO enzyme (Geier et al., 2009; Grossmann et al., 2010). Because saflufenacil action takes place rapidly causing loss of membrane integrity, it could reduce the effectiveness of other herbicides when used in tank-mixed applications. This effect has been demonstrated with other PPO inhibitors such as diphenylether herbicides. Nelson et al. (1998) reported on the antagonistic effect of lactofen tank-mixed with imazethapyr resulting in reduced giant foxtail (*Setaria faberi* Herrm.) control, however, the same combination increased common ragweed (*Ambrosia artemisiifolia* L.) control. Synergism, antagonism, or no interaction of tank-mixed application of PPO inhibitors had been reported and results were dependent on weed species, herbicide tested, and

rates applied (Beyers et al., 2002; Unland et al., 1999; Wesley and Shaw, 1992).

Reduction in red rice control by tank-mixing saflufenacil and imazethapyr would limit their use in a simultaneous application.

More information is needed to understand the potential benefit of saflufenacil and saflufenacil plus imazethapyr combinations for rice weed control programs. Studies were established to evaluate 1) rice tolerance and 2) control of red rice and hemp sesbania by application of saflufenacil tank-mixed with imazethapyr.

## **MATERIAL AND METHODS**

The experiments were conducted during 2009 and 2010 at the Texas A&M AgriLife Research and Extension Center located near Beaumont, TX. The soil was a Morey loam (fine-silty, siliceous, superactive, hyperthermic Oxyaquic Argiudolls) with 29.4% of sand, 46.5% of silt, 24.1% of clay, 1.21% of organic carbon, and pH of 7.8. The research area was in a rice-fallow rotation where rice was seeded every three years. During the summer, soil was disked to reduce vegetation biomass. Prior to crop establishment in the spring, the seedbed was cultivated again and the soil surface was graded to ensure adequate field slope.

The experiments were drill-seeded on April 9<sup>th</sup>, 2009, and April 14<sup>th</sup>, 2010 using the imazethapyr-resistant hybrid 'CL XL729' at the rate of 40 kg ha<sup>-1</sup>. Rice emergence occurred 14 days after seeding the experiments in both years. Plots were formed by seven rows spaced 19 cm from each other (1.3 m wide) and measuring 5.5 m long in 2009 and 4.8 m long in 2010. Red rice (*Oryza sativa*), and hemp sesbania (*Sesbania*

*exaltata*) were seeded in the plots to ensure weed populations. Two strips with six rows of strawhulled red rice were drill-seeded perpendicular to the plots length using a rate of 50 kg ha<sup>-1</sup>. Hemp sesbania seed was broadcast over plots at the rate of 12 kg ha<sup>-1</sup> and a cultipacker was used to incorporate seeds into the soil surface. Flushing irrigation, which consists of flooding the field and subsequently draining it, was used to introduce moisture in the soil before establishing permanent flooding. In both years, permanent irrigation was initiated 33 days after rice emergence. Experiments were fertilized using triple superphosphate at a rate of 65 kg ha<sup>-1</sup> of P<sub>2</sub>O<sub>5</sub> pre-plant incorporated followed by split application of urea at 135 kg ha<sup>-1</sup> of nitrogen pre-flooding plus 35 kg ha<sup>-1</sup> of nitrogen at panicle differentiation.

The experimental design was a randomized complete block with four replications. Treatments included an untreated check, an imazethapyr (Newpath<sup>®</sup>) treatment alone (70 g a.i. ha<sup>-1</sup> at the 2- to 3-leaf stage (EPOST) plus 70 g ha<sup>-1</sup> at the 4- to 6-leaf stage (LPOST)), and four saflufenacil (Sharpen<sup>®</sup>) doses (12.5, 18.75, 25, and 50 g a.i. ha<sup>-1</sup>) applied at EPOST and LPOST, resulting in a total of 10 treatments. Imazethapyr treatments were applied to all saflufenacil treatments. EPOST or LPOST saflufenacil applications were tank-mixed with either the first or second application of imazethapyr depending on the treatment. Triclopyr (420 g a.e. ha<sup>-1</sup>) was applied LPOST in the imazethapyr treatment alone to provide hemp sesbania suppression. In this treatment remaining hemp sesbania plants were manually removed after triclopyr action. This was necessary for late-season assessment of red rice control from imazethapyr.

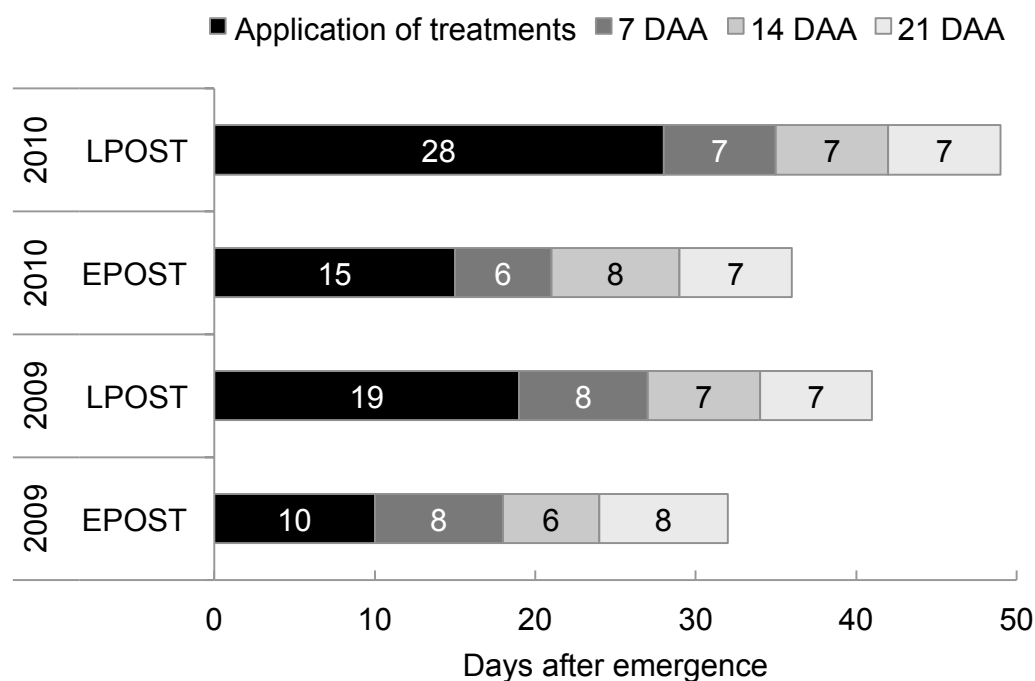

**Figure 3.** Treatment applications at 2- to 3-leaf stage (EPOST) and 4- to 6-leaf stage (LPOST) with subsequent assessment intervals in days after saflufenacil application (DAA). Applications and/or evaluations were conducted where color changes occur on the bars. Number inside the bars represents the numbers of days after emergence for the application of the treatments and/or execution of the visual assessment. Evaluations conducted for the same bar color were used for statistical comparisons.

Methylated seed oil (blend of distilled methyl esters and nonionic surfactants, Helena Chemical Company, Collierville, TN) at 1% v/v was included in all POST applications. Treatment applications were performed using a boom equipped with three flat-fan nozzles (Teejet XR11002, Spraying Systems Co., Wheaton, IL) spaced 50 cm apart. Boom was coupled to a CO<sub>2</sub>-pressurized backpack sprayer calibrated to deliver 140 L ha<sup>-1</sup> of spray solution at 172 kPa. Red rice was at the 2- and 5-leaf stage and hemp



sesbania at 2- and 6- compound leaf stage in the moment of EPOST and LPOST applications, respectively.

Rice injury, red rice and hemp sesbania control were estimated visually using a scale of 0 to 100% where 0 = no rice injury or no control and 100 = rice death or total control. Visual assessments were targeted for 7, 14 and 21 days after saflufenacil applications plus a final evaluation before harvesting. Data were collected 1 to 2 days around these target timings (Figure 3). Rice heading was determined to be the moment in which more than 50% of the plants had the panicle emerged from the leaf sheath (Counce et al., 2000). Four plot rows were harvested with a mechanical harvester when grain moisture was approximately 20%. Harvested samples were weighted and a moisture meter was used to determine the moisture content of individual samples. Final grain yield was adjusted to 12% moisture and converted to  $\text{kg ha}^{-1}$ . Subsequently, a sub-sample was removed, dried and used to quantify milling yield.

All data were subjected to ANOVA using the PROC MIXED procedure of SAS (Statistical Analysis Systems, 9.2 Software, SAS Institute Inc., Cary, NC). Injury and weed control data were subjected to arcsine square-root transformation prior to analysis. Afterward, error assumptions (independence, homogeneity, and normality) were verified using Bartlett's and Shapiro-Wilk's Test. Data were combined within years, therefore variances were partitioned into random effects (years, blocks within years and year by treatment interactions) and fixed effects (herbicide treatments). Results were combined when interactions of year x herbicide treatments were not significant. Means for significant effects were separated using Tukey's Test ( $p \leq 0.05$ ).

## RESULTS AND DISCUSSION

### Rice injury

ANOVA indicated an herbicide treatment by year interaction for rice injury data collected at 7 and 14 days after saflufenacil applications (DAA) (data not shown). Therefore, results were presented for each year separately. Saflufenacil injury symptoms are characterized by chlorosis of the leaves followed by necrosis of the affected tissues. Overall, visual injury increased as saflufenacil dose increased from 12.5 to 50 g ha<sup>-1</sup> in both years (Table 6). In the year 2009, evaluations conducted at 7 DAA demonstrated injury as high as 53% when the highest dose of saflufenacil was applied EPOST. Statistically similar injury (38%) was observed when the same dose was applied LPOST. Treatments containing the lowest dose of saflufenacil applied EPOST and LPOST displayed injury lower than 10%.

In 2010, saflufenacil applied at 50 g ha<sup>-1</sup> EPOST caused as much as 83% injury in evaluations conducted at 7 DAA. In the same evaluation, treatment containing 12.5 g ha<sup>-1</sup> applied EPOST resulted in 43% injury, which was significantly higher than the 6% observed when saflufenacil was applied at the same dose LPOST. Therefore, saflufenacil applied LPOST at 12.5 g ha<sup>-1</sup> resulted in injury lower than 10% in both years at the initial evaluation. Rice yield would most probably not be affected by this LPOST injury as rice plants could recover throughout the season. Currently, no work

**Table 6.** Rice (*Oryza sativa* L.) visible injury in response to postemergence tank-mix applications of saflufenacil (S) and imazethapyr (I) at different growth stages.<sup>a</sup>

Treatments			Visual injury <sup>b</sup>			
			7 DAA		14 DAA	
Herbicide	S dose (g ha <sup>-1</sup> )	S timing	2009	2010	2009	2010
			-----%-----			
Untreated	0	NONE	0 e <sup>d</sup>	0 d	0 d	0 c
I <sup>c</sup>	0	NONE	0 e	0 d	0 d	0 c
I + S	12.5	EPOST	9 d	43 b	13 b	8 b
I + S	18.75	EPOST	13 d	63 b	15 b	13 ab
I + S	25	EPOST	14 dc	63 b	15 b	11 ab
I + S	50	EPOST	53 a	83 a	50 a	16 a
I + S	12.5	LPOST	10 d	6 cd	3 cd	0 c
I + S	18.75	LPOST	14 dc	8 cd	8 bc	0 c
I + S	25	LPOST	26 bc	9 c	10 bc	0 c
I + S	50	LPOST	38 ab	10 c	14 b	0 c

<sup>a</sup>Abbreviations: NONE, no application of saflufenacil; EPOST, early postemergence (2- to 3-leaf stage); LPOST, late postemergence (4- to 6-leaf stage); DAA, days after application of saflufenacil. <sup>b</sup>Injury was estimated visually using a scale of 0 to 100% where 0 = no rice injury and 100 = rice death. <sup>c</sup>Imazethapyr was applied to all treatments at 70 g a.i. ha<sup>-1</sup> EPOST plus 70 g a.i. ha<sup>-1</sup> LPOST, except the untreated. For imazethapyr alone visual injury was collected at 7 and 14 days after EPOST applications. Triclopyr (420 g a.e. ha<sup>-1</sup>) was applied LPOST to plots receiving imazethapyr alone. <sup>d</sup>Means followed by a different letter are significantly different according to the Tukey's test ( $p \leq 0.05$ ).

has been published studying rice response to saflufenacil applications. Sikkema et al. (2008) observed intense injury from POST application of saflufenacil in winter cereals and it remained as high as 35% almost one month after treatment.

Later evaluations showed less injury demonstrating rice recovery among saflufenacil treatments. Although injury from EPOST treatments at 7 DAA ranged from 9 to 83% over the years, rice plants were able to recover and results obtained at 14 DAA demonstrated injury ranging from 8 to 15% for treatments containing 12.5, 18.75, and 25 g ha<sup>-1</sup> of saflufenacil. However, LPOST application of saflufenacil demonstrated rapid plant recovery in 2009 and lower initial injury in 2010 when compared with EPOST treatments. In evaluations conducted at 14 DAA, treatments from 12.5 to 25 g ha<sup>-1</sup> showed injury lower than 10% in 2009 and no injury was observed for all doses in 2010 for LPOST applications.

Although injury was observed from applications of saflufenacil at 4- to 6-leaf rice stage plants were able to overcome burning symptoms faster. Some factors may be favoring the injured plants later in the season such as elevation in temperature, which intensifies growth rate and results in production of new tissues and leaves. Also, nitrogen application and permanent flood were introduced shortly after the LPOST stage. These management practices would likely help injured rice overcome injury more rapidly.

In 2009, the treatments containing 50 g ha<sup>-1</sup> of saflufenacil had 16 and 5% injury for the EPOST and LPOST applications, respectively, in evaluation conducted 21 DAA (data not shown). In 2010, no injury was observed in any treatment at this assessment.

No injury was observed in the imazethapyr treatment alone in any of the evaluations either year.

Rice heading was not affected by herbicides treatments among years. This indicates that rice development was not altered by injury observed early in the season from saflufenacil treatments. However, in the untreated check heading was delayed and almost absent due to suppression of rice growth and development caused by weed presence. Averaging across herbicide treatments and years, 50% heading was observed approximately  $80 (\pm 3)$  days after rice emergence.

### **Hemp sesbania control**

Results were combined over years since no treatment by year interaction was revealed by ANOVA. Saflufenacil provided excellent control of hemp sesbania independently of the dose and the time of application (Table 7). Even the lowest dose of saflufenacil applied LPOST provided hemp sesbania control of up to 99% in evaluations conducted 7 DAA. It is important to reinforce that hemp sesbania plants controlled with the LPOST application were at the 6-leaf stage. Control was slightly reduced from 7 to 21 DAA, but no significant differences were observed among saflufenacil doses. Saflufenacil was effective in controlling other broadleaves with doses varying according to species (Geier et al., 2009). Results obtained in this study suggest that hemp sesbania was susceptible to saflufenacil.

**Table 7.** Hemp sesbania control (*Sesbania exaltata*) in response to postemergence tank-mix applications of saflufenacil (S) and imazethapyr (I) at different growth stages. Data average across years.<sup>a</sup>

Treatments			Hemp sesbania control <sup>b</sup>		
Herbicide	S dose (g ha <sup>-1</sup> )	S timing	7DAA	21DAA	Preharvest
			-----%-----		
Untreated	0	NONE	0 b <sup>d</sup>	0 b	0 c
I <sup>c</sup>	0	NONE	--	--	--
I + S	12.5	EPOST	100 a	96 a	88 b
I + S	18.75	EPOST	100 a	98 a	92 ab
I + S	25	EPOST	100 a	97 a	89 ab
I + S	50	EPOST	100 a	97 a	89 ab
I + S	12.5	LPOST	99 a	97 a	89 ab
I + S	18.75	LPOST	100 a	98 a	94 ab
I + S	25	LPOST	100 a	98 a	93 ab
I + S	50	LPOST	100 a	98 a	96 a

<sup>a</sup>Abbreviations: NONE, no application of saflufenacil; EPOST, early postemergence (2- to 3-leaf stage); LPOST, late postemergence (4- to 6-leaf stage); DAA, days after application of saflufenacil. <sup>b</sup>Hemp sesbania control was estimated visually using a scale of 0 to 100% where 0 = no control and 100 = total hemp sesbania control. <sup>c</sup>Imazethapyr was applied to all treatments at 70 g a.i ha<sup>-1</sup> EPOST plus 70 g a.i ha<sup>-1</sup> LPOST, except the untreated. Although, triclopyr (420 g a.e. ha<sup>-1</sup>) was applied LPOST to plots receiving imazethapyr alone to reduce hemp sesbania pressure, control results for this treatment were not presented. <sup>d</sup>Means followed by a different letter are significantly different according to the Tukey's test ( $p \leq 0.05$ ).

In evaluations conducted before harvest, hemp sesbania control was  $\geq 88\%$  in all saflufenacil treatments, indicating effectiveness of control throughout the rice season. Saflufenacil applied at  $12.5 \text{ g ha}^{-1}$  EPOST provided somewhat lower long-season control (88%) than  $50 \text{ g ha}^{-1}$  applied LPOST (96%), but these treatments had similar control when compared with remaining saflufenacil doses and timings. The lower dose of saflufenacil was effective in controlling hemp sesbania EPOST as demonstrated in evaluations conducted 7 DAA. However, it seemed that saflufenacil residual in the soil was not adequate to control the hemp sesbania plants that emerged after the EPOST application. Treatments applied at LPOST would be favored once saflufenacil could be applied close to the establishment of flooding and water management would minimize the emergence of weeds.

Although hemp sesbania control was satisfactory with only one application of saflufenacil, it will be interesting to investigate in the future if use of lower doses of saflufenacil with both the EPOST and LPOST applications of imazethapyr resulting in more consistent results across different environmental conditions with acceptable crop injury.

### **Red rice control**

Results were presented for each year separately as ANOVA indicated a significant herbicide treatment by year interaction. Red rice control was not adversely affected by tank-mixing saflufenacil with imazethapyr (Table 8). In fact, red rice control was higher in treatments including saflufenacil than in treatments containing

**Table 8.** Red rice (*Oryza sativa* L.) control in response to postemergence tank-mix applications of saflufenacil (S) and imazethapyr (I) at different growth stages.<sup>a</sup>

Treatments			Red rice control <sup>b</sup>			
			14 DAA		21 DAA	
Herbicide	S dose (g ha <sup>-1</sup> )	S timing	2009	2010	2009	2010
			-----%-----			
Untreated	0	NONE	0 d <sup>d</sup>	0 d	0 b	0 c
I <sup>c</sup>	0	NONE	93 c	55 c	98 a	75 b
I + S	12.5	EPOST	98 b	78 bc	100 a	93 a
I + S	18.75	EPOST	98 b	83 ab	100 a	93 a
I + S	25	EPOST	99 b	80 ab	100 a	93 a
I + S	50	EPOST	100 a	93 a	100 a	96 a
I + S	12.5	LPOST	100 a	91 ab	100 a	100 a
I + S	18.75	LPOST	100 a	95 a	100 a	100 a
I + S	25	LPOST	100 a	95 a	100 a	100 a
I + S	50	LPOST	100 a	90 ab	100 a	100 a

<sup>a</sup>Abbreviations: NONE, no application of saflufenacil; EPOST, early postemergence (2- to 3-leaf stage); LPOST, late postemergence (4- to 6-leaf stage); DAA, days after applications of saflufenacil. <sup>b</sup>Red rice control was estimated visually using a scale of 0 to 100% where 0 = no control and 100 = total red rice control. <sup>c</sup>Imazethapyr was applied to all treatments at 70 g a.i. ha<sup>-1</sup> EPOST plus 70 g a.i. ha<sup>-1</sup> LPOST, except the untreated. For imazethapyr alone visual injury was collected at 7 and 14 days after EPOST applications. Triclopyr (420 g a.e. ha<sup>-1</sup>) was applied LPOST to plots receiving imazethapyr alone. <sup>d</sup>Means followed by a different letter are significantly different according to the Tukey's test ( $p \leq 0.05$ ).



imazethapyr alone in evaluations conducted at 14 and 21 DAA in both years. It is important to clarify that results presented for untreated, imazethapyr alone, and imazethapyr plus saflufenacil EPOST were collected at different times than the results for imazethapyr plus saflufenacil LPOST (Figure 3). Nevertheless, if comparisons are to be made using data collected during the same period (e.g. imazethapyr alone with imazethapyr plus saflufenacil EPOST applications) higher control was observed in the treatments containing saflufenacil, especially early in the season.

Burning injury from saflufenacil in association with imazethapyr activity displayed a more rapid visually response and control of red rice when compared with imazethapyr alone. Subsequent evaluations had shown that control in the imazethapyr alone treatment would improve as this herbicide generally has slow action and symptoms require one to two weeks or more to display (Senseman, 2007). In evaluations conducted before harvest, red rice control was 100% for all treated plots containing imazethapyr in both years (data not shown) indicating no antagonistic interaction between saflufenacil and imazethapyr.

### **Grain yield**

Results were combined over years since no treatment by year interaction was revealed by ANOVA. Rice yield was similar among saflufenacil treatments and imazethapyr treatment alone and therefore it was not affected by saflufenacil doses and timings (Figure 4). Although injury was significantly higher with highest doses of saflufenacil, rice yield was not adversely affected. In barley, oats and wheat, Sikkema et

al. (2008) demonstrated that POST applications of saflufenacil caused yield reduction. It is suggested that the rate of growth during the summer season and rice crop management (nitrogen fertilization and season-long flooding) can be associated with recovery of rice from saflufenacil POST applications injury when compared with winter crops.

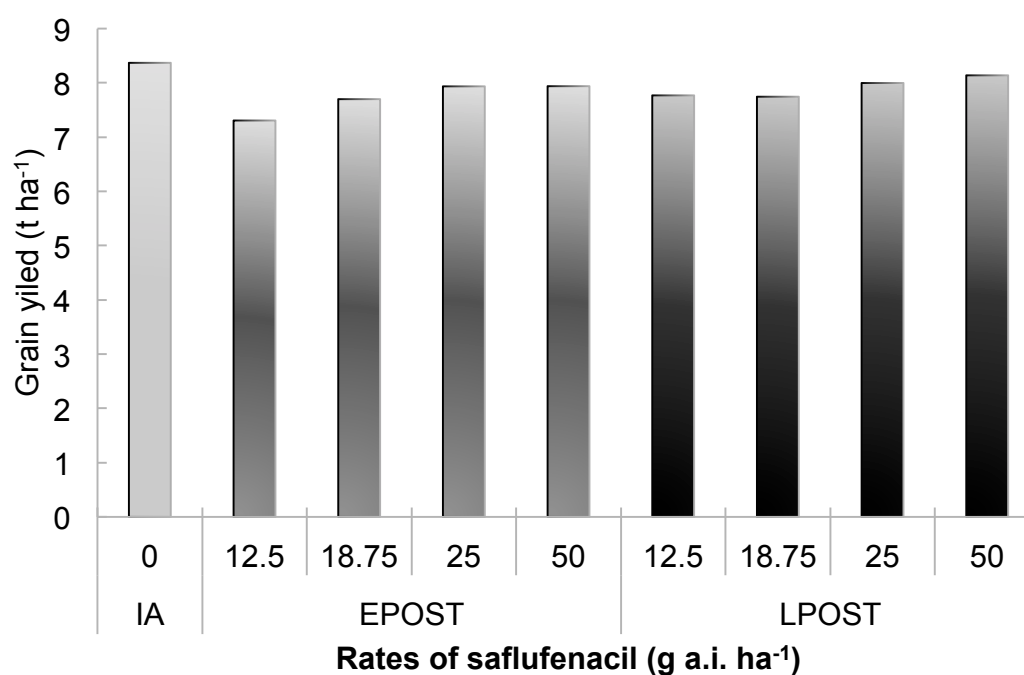

**Figure 4.** Rice grain yield (t ha<sup>-1</sup>) in response to postemergence tank-mix applications of saflufenacil and imazethapyr at 2- to 3-leaf stage (EPOST) and 4- to 6-leaf stage (LPOST). Triclopyr (420 g a.e. ha<sup>-1</sup>) was applied LPOST to plots receiving imazethapyr alone (IA). Data average across years. No significant difference according to the Tukey's test ( $p \leq 0.05$ ).

In both years, none of the untreated plots could be harvested due the weed pressure. Therefore, results from the untreated check were analyzed as missing data and would not be presented in the results. Obviously, the weed control was fundamental to achieve around 8 t ha<sup>-1</sup> of crop yield on the average of herbicide treatments.

No differences were observed among herbicides treatments regarding whole grain. This would be an expected result considering that no observation of heading delays was reported due saflufenacil injury. Whole grain average was 56% for herbicide treatments across years.

## **CONCLUSIONS**

In summary, rice was injured with the highest doses of saflufenacil, but injury did not reduce rice yield in two years of study. Hemp sesbania was effectively controlled by saflufenacil. Imazethapyr control of red rice was not adversely affected by tank-mixing with saflufenacil. Saflufenacil appears to be an effective herbicide candidate for broadleaf control in rice. As for future research, experiments should investigate the combination of saflufenacil with both the EPOST and LPOST applications of imazethapyr. Also, studies are needed to understand the effect of saflufenacil on absorption and translocation of imazethapyr in red rice.

## CHAPTER IV

### INTERACTION BETWEEN SAFLUFENACIL AND IMAZETHAPYR IN RED RICE (*Oryza ssp.*) AND HEMP SESBANIA (*Sesbania exaltata*) AS AFFECTED BY LIGHT INTENSITY\*

#### INTRODUCTION

Saflufenacil is a broadleaf herbicide registered in the United States during 2010 for pre-plant burndown and PRE applications in several crops. This new molecule is the active ingredient in the Kixor<sup>®</sup> Herbicide Technology which resulted in labeling of four commercial products by BASF. In one of the products with a trade name of Sharpen<sup>®</sup>, 66 broadleaf weed species are listed under effective burndown applications. Saflufenacil is a member of the pyrimidinedione family of herbicides, which inhibits the PPO enzyme (Grossmann et al., 2010). PPO leads the conversion of protoporphyrinogen IX (PPGIX) to protoporphyrin IX (PPIX) in the chlorophyll and heme biosynthesis pathway (Hess, 2000; Duke et al., 1991; Senseman, 2007). Inhibition of PPO results in transitional accumulation of PPGIX in the chloroplast until it diffuses into the cytoplasm (Lehnen et al., 1990). Outside of its normal site, PPGIX is converted to PPIX by herbicide insensitive enzymes (Jacobs and Jacobs, 1993; Jacobs et al., 1991; Lee et al., 1993).

---

\*Reprinted with permission from “Interaction between saflufenacil and imazethapyr in red rice (*Oryza ssp.*) and hemp sesbania (*Sesbania exaltata*) as affected by light intensity” by Camargo, E.R., Senseman, S.A., McCauley, G.N., Bowe, S., Harden, J., Guice, J.B., 2011. *Pest Manag. Sci.*, doi:10.1002/ps.3260. Copyright 2011 Society of Chemical Industry, first published by John Wiley & Sons Ltd.

Subsequently, PPIX which is the first light-absorbing chlorophyll precursor, reacts with light and oxygen to generate singlet oxygen causing lipid peroxidation (Hess, 2000; Senseman, 2007). Hence, membrane leakage occurs resulting in rapid disintegration of cells and cell organelles (Duke et al., 1991). Therefore, PPO inhibiting compounds such as saflufenacil are fast-acting, light-dependent herbicides that result in wilting and necrosis symptoms on vulnerable plant species (Grossmann et al., 2010).

Although POST application is not currently recommended in row crops, recent studies have demonstrated potential for applying saflufenacil after crop emergence. In winter wheat, saflufenacil POST applications in combination with 2,4-D amine without surfactant caused less than 15% foliar necrosis with no reduction in dry weight and grain yield (Frihauf et al., 2010b; Frihauf et al., 2010c). Also, the water-dispersible granule formulation resulted in minimal injury for POST applications of saflufenacil in winter wheat (Frihauf et al., 2010c). The sodium salt of bentazon used in tank-mixed applications with saflufenacil in corn demonstrated a safening effect by reducing injury and increasing crop dry weight compared with saflufenacil alone. Foliar uptake of saflufenacil was diminished when bentazon was added in the application (Moran et al., 2011). In rice, saflufenacil was successfully used in POST applications providing control of broadleaf species (Camargo et al., 2012; Meier et al., 2010) and has the potential for broadening the weed spectrum in control programs for rice (Camargo et al., 2011; Camargo et al., 2012).

As a POST herbicide, the rapid loss of membrane integrity caused by saflufenacil herbicidal action could reduce the effectiveness of other herbicides when used in tank-

mixed applications. Previous studies with PPO inhibitor herbicides such as diphenylethers have demonstrated an antagonistic effect on control of weeds in combination with other herbicidal mechanisms of action, especially the acetolactate synthase enzyme (ALS) inhibitors. However, the magnitude of the interaction was affected by weed species, herbicides, and rate applied (Nelson et al., 1998; Unland et al., 1999; Wesley and Shaw, 1992). In a CLEARFIELD<sup>®</sup> rice production system, saflufenacil tank-mixed with the imazethapyr (ALS inhibitor) to expand the weed control range, provided faster control of red rice (*Oryza sativa* L.) when compared with imazethapyr alone (Camargo et al., 2012). Imazethapyr absorption and translocation in red rice plants may be associated with an interaction mechanism observed for these two herbicides. Uptake and herbicide movement are frequently identified as the primary causes of herbicide interactions (Ashigh and Hall, 2010; Eubank et al., 2010; Frihauf et al., 2010a; Moran et al., 2011; Unland et al., 1999). Therefore, these aspects should be investigated to elucidate the effects of saflufenacil on action of imazethapyr in red rice.

Furthermore, herbicidal action of PPO inhibitors is dependent on light availability. This environmental factor is not only essential for oxygen radical production resulting in loss of membrane integrity and functionality (Grossmann et al., 2010), but it is also required for biosynthesis of chlorophyll in angiosperms (Belyaeva and Litvin, 2009), the pathway of inhibition by PPO herbicides. Light intensity effects on activity of herbicides from distinct mechanism had been demonstrated in crops and weeds. Symptoms of glufosinate, a glutamine synthetase inhibitor, became visible faster in plants receiving light as compared with plants that had no light (Köcher, 1983). In the same study,

ammonia accumulation occurred more rapidly in mono and dicotyledonous species under light exposure, indicating faster action of the herbicide. On the other hand, phytotoxicity of fenoxaprop-ethyl (acetyl CoA carboxylase inhibitor) and imazamethabenz-methyl (ALS inhibitor) in wild oat (*Avena fatua* L.) was enhanced under lower light intensity ( $120 \mu\text{mol m}^{-2} \text{s}^{-1}$ ) when compared with a higher intensity ( $400 \mu\text{mol m}^{-2} \text{s}^{-1}$ ) (Xie et al., 1996). The authors associated these differences primarily due to the spray deposition of the herbicides and secondarily to the shading-induced changes in absorption and translocation. Soybean, corn and wheat plants that were covered with 80% shade cloth ( $200 \mu\text{mol m}^{-2} \text{s}^{-1}$ ) for 5 days before application of carfentrazone (PPO inhibitor) displayed greater injury compared with the full-sunlight ( $1800$  to  $2000 \mu\text{mol m}^{-2} \text{s}^{-1}$ ). Injury differences were especially apparent for soybean (Thompson and Nissen, 2002). Therefore, light intensity can alter the speed of herbicide action, the herbicide mobility within plants and ultimately, plant responses.

This would be particularly important for saflufenacil where levels of light intensity could alter the photo-activation of PPIX resulting in differential herbicidal action with possible effects on absorption and translocation in broadleaf species such as hemp sesbania (*Sesbania exaltata*). Additionally, an interaction with saflufenacil could alter imazethapyr absorption and translocation due to membrane disruption in red rice depending on light availability. Perhaps, this is the acting mechanism(s) responsible for faster control of red rice plants in a rice weed control program combining saflufenacil and imazethapyr (Camargo et al., 2012). Understanding uptake and mobility of saflufenacil and imazethapyr under varying levels of light intensity may help in future

management decisions involving these two herbicides in rice. The objectives of this study were (1) to investigate the effects of saflufenacil POST application and light intensity levels on imazethapyr absorption and translocation in red rice plants, and (2) to determine the influence of imazethapyr and light intensities on saflufenacil absorption and movement in hemp sesbania plants.

## **MATERIALS AND METHODS**

### **Plant material and growth conditions**

Red rice (TX4 ecotype) and hemp sesbania seeds were planted in 3.8-cm diameter by 21-cm deep cones containing approximately 80 cm<sup>3</sup> of potting medium (Metro-Mix 200, Sun Gro Horticulture Distribution Inc., Bellevue, WA). TX4 ecotype was selected as the red rice source because is well characterized in the literature regarding its biological (Noldin et al., 1999b) and genetic (Vaughan et al., 2001) traits and it had demonstrated distinctive tolerance to imazethapyr (Avila et al., 2005a; Gealy and Black, 1999) and other herbicides (Noldin et al., 1999a) in previous studies. Deep cones were initially pre-filled and well packed with potting mix. Subsequently, three weed seeds were placed on top of the pre-filled cones and covered with 1 to 2 cm of growing substrate. Rack holders containing weed-seeded cones were placed inside of the growth chamber. Growth media was then irrigated to stimulate seed germination. Moisture was retained by keeping the lower portion of the cone submerged in a water bath. Growth chamber conditions were set to perform a 14-h photoperiod with a 30:25 °C day:night temperature regime. These conditions were used during germination and



vegetative growing stages of the weed plants before herbicide application. After emergence, only one weed plant was maintained per cone. Plants were fertilized after emergence in a biweekly interval using liquid fertilizer (HastaGro 14-4-8, Medina Agriculture Products, Hondo, TX) via subirrigation water.

### **Absorption and translocation**

A separate study was conducted for each weed species. In the red rice study the two-herbicide treatments consisted of imazethapyr alone ( $70 \text{ g ha}^{-1}$ ) and imazethapyr plus saflufenacil ( $70 \text{ g ha}^{-1} + 12.5 \text{ g ha}^{-1}$ , respectively). Herbicide treatments in the hemp sesbania study included saflufenacil alone ( $12.5 \text{ g ha}^{-1}$ ) and saflufenacil plus imazethapyr ( $12.5 \text{ g ha}^{-1} + 70 \text{ g ha}^{-1}$ , respectively). Methylated seed oil (MSO, blend of distilled methyl esters and nonionic surfactants, Helena Chemical Company, Collierville, TN) at 1% v/v was included in all herbicide treatments. Herbicide applications were made using the commercial formulation of imazethapyr (Newpath<sup>®</sup>, BASF Corporation, Research Triangle Park, NC) and saflufenacil (Sharpen<sup>®</sup>, BASF Corporation, Research Triangle Park, NC).

Red rice plants were at the 3-leaf stage and hemp sesbania at the 4-5 compound leaf stages at the time of herbicide treatment applications. An air-driven spray chamber equipped with one flat-fan nozzle (Teejet XR11002, Spraying Systems Co., Wheaton, IL) delivering  $140 \text{ L ha}^{-1}$  of solution was used to apply the herbicides. Plants were spotted with  $5 \mu\text{L}$  of  $^{14}\text{C}$ -labeled herbicides within 0.5 hours after treatment (HAT) with the formulated products. Solutions of [pyridine- $^{14}\text{C}$ ] imazethapyr ( $5.5 \text{ MBq}$ , specific

activity of 1589 kBq  $\mu\text{mol}^{-1}$ ) and [phenyl- $^{14}\text{C}$ ] saflufenacil (4.6 MBq, specific activity of 2329 kBq  $\mu\text{mol}^{-1}$ ) were prepared in 10 mL of HPLC grade methanol. Subsequently, a working solution containing 0.33 kBq  $\mu\text{L}^{-1}$  of methanol was prepared and used for spotting the leaf receiving the  $^{14}\text{C}$ -labeled herbicides. Therefore, the amount of radioactivity applied was approximately 1.67 kBq  $\text{plant}^{-1}$ . Radioactive  $^{14}\text{C}$ -imazethapyr applied in the red rice plants was insignificant compared with the rate of commercial herbicide. However, in the hemp sesbania study the 12.5 g  $\text{ha}^{-1}$  rate represented a combination of commercial saflufenacil (10 g  $\text{ha}^{-1}$ ) and  $^{14}\text{C}$ -saflufenacil (2.5 g  $\text{ha}^{-1}$ ).

The working solution was spotted as five droplets on the adaxial surface of the leaf. In the red rice plants  $^{14}\text{C}$ -imazethapyr was applied to the middle leaf of 3-leaf red rice. In the hemp sesbania study, the first true leaf, which is a simple single leaf, was selected for treatment with  $^{14}\text{C}$ -saflufenacil. The small size of hemp sesbania leaflets and their tendency of folding at very low light intensities were aspects considered for applying the simple, single-leaf. Plants were kept shaded during transport from the spray chamber to the laboratory. Also, plants had to be maintained under non-direct light exposure during the  $^{14}\text{C}$ -herbicide applications.

After applying the herbicide treatments and spotting the leaves with  $^{14}\text{C}$ -herbicides, plants were placed back in the growth chamber. Shade cloths (Catalog Clearance, Libertyville, IL) were placed inside the growth chamber over the treated plants to generate the light intensity regimes. Four levels of light intensity (1066  $\mu\text{mol m}^{-2} \text{s}^{-1}$ , 677  $\mu\text{mol m}^{-2} \text{s}^{-1}$ , 259  $\mu\text{mol m}^{-2} \text{s}^{-1}$ , and 106  $\mu\text{mol m}^{-2} \text{s}^{-1}$ ) were generated by using 0% (no shade), 30%, 70%, and 90% shade cloths, respectively. The no-shade treatment received

the full light capability of the growth chamber supplied by low-pressure sodium vapor lamps, VHO fluorescent bulbs, and clear incandescent bulbs. Light intensity readings were conducted 4 times over the course of each weed study using a LI-COR light meter (Model LI-250, LI-COR Corporate, Lincoln, NE) coupled with a line quantum sensor (Model LI-191SA, LI-COR Corporate, Lincoln, NE). Light intensity readings represented the photosynthetically active radiation.

Red rice and hemp sesbania plants were maintained under light regimes according to treatments until harvest. Red rice plants were harvested at 1, 6, 24, 72, and 168 HAT with  $^{14}\text{C}$ -imazethapyr. Hemp sesbania plants were harvested at 0.5, 3, 6, 12, and 24 hours after  $^{14}\text{C}$ -saflufenacil applications. At harvest, the treated leaf was excised and washed with deionized water followed by methanol to remove  $^{14}\text{C}$ -herbicides from the leaf surface and epicuticular wax, respectively. Separate scintillation vials were prepared with 3 mL of water and methanol. The treated leaf was inserted inside the vial containing water and it was shaken for 5 s. After shaking, the process was repeated on the vial containing methanol. Ten mL of liquid scintillation cocktail was added to the leaf washes. Plants were sectioned into 1) the treated leaf (TL), 2) the portion of plant above-treated leaf (ATL), 3) the aerial portion of plant below-treated leaf (BTL), and 4) the root system (RS).

Plant sections were dried in an oven at 55 °C for 72 h. Dried samples were combusted with a biological sample oxidizer (OX500, R.J. Harvey Instrument Corporation, Tappan, NY). Radioactivity from washes and combusted samples radioactivity was quantified by liquid scintillation spectrometry (Beckman LS6500

Liquid Scintillation Counter, Beckman Coulter Inc., Brea, CA). Percentage of herbicide absorption was calculated by dividing the sum of radioactivity quantified in all plant sections by the radioactivity applied on the treated leaf. Radioactivity quantified in the leaf washes was considered a non-absorbed fraction and used for estimation of recovery. Percentage of herbicide translocation represents the fraction of absorbed  $^{14}\text{C}$ -herbicide that moved out of the treated leaf to the other sections of the plant. The herbicide recovery was 92% for  $^{14}\text{C}$ -imazethapyr in red rice and 80% for  $^{14}\text{C}$ -saflufenacil in hemp sesbania plants.

### **Statistical analysis**

Experiments were conducted in a randomized complete block design with a factorial arrangement of herbicide treatments, light intensities, and harvest times. Each weed experiment was repeated twice and every treatment combination was replicated three times per run of the experiment. Absorption and translocation data were subjected to ANOVA using SAS (Statistical Analysis Systems, 9.2 Software, SAS Institute Inc., Cary, NC). Prior to analysis, data were subjected to logarithmic transformation. Subsequently, error assumptions (independence, homogeneity, and normality) were verified using Bartlett's and Shapiro-Wilk's Test. *F*-values obtained for individual sources of variation (herbicide, light intensity, and harvest time) and for multiple combinations of the three factors are presented in Table 9 and 10. Means for significant effects were separated using Tukey's Test ( $p \leq 0.05$ ) and/or 95% confidence intervals.

Non-linear regression models (Frihauf et al., 2010a) were used to indicate overall patterns of treatments in some of the investigated responses.

**Table 9.** *F*-values of ANOVA for absorption (AB), translocation (TR), and distribution of absorbed imazethapyr in TX4 red rice (*Oryza* spp.) ecotype. Percentage of absorbed herbicide located above-treated leaf (ATL), in the aerial parts of the plant below-treated leaf (BTL), and in the root system (RS) was used to study imazethapyr distribution.

Source of variation	<i>F</i> -value				
	AB	TR	ATL	BTL	RS
Block	4.92**	5.49**	11.28**	0.65 NS	0.89 NS
Herbicide (H)	9.90**	8.76**	1.11 NS	0.28 NS	15.91**
Light intensity (I)	1.40 NS	1.61 NS	0.34 NS	0.63 NS	4.51**
Harvest timing (T)	11.13**	135.15**	243.77**	336.20**	10.11**
H x I	0.49 NS	0.61 NS	0.36 NS	1.82 NS	0.04 NS
H x T	1.49 NS	0.94 NS	3.07*	0.82 NS	0.45 NS
I x T	0.54 NS	0.94 NS	1.19 NS	1.83*	2.04 NS
H x I x T	0.48 NS	0.47 NS	0.70 NS	0.55 NS	2.33*

NS = not significant. \* Significant at  $P \leq 0.05$ . \*\* Significant at  $P \leq 0.01$ .

**Table 10.** *F*-values of ANOVA for absorption (AB), translocation (TR), and distribution of absorbed saflufenacil in hemp sesbania (*Sesbania exaltata*). Percentage of absorbed herbicide located above-treated leaf (ATL), in the aerial parts of the plant below-treated leaf (BTL), and in the root system (RS) was used to study saflufenacil distribution.

Source of variation	<i>F</i> -value				
	AB	TR	ATL	BTL	RS
Block	2.10 NS	5.04**	3.05*	2.66*	2.04 NS
Herbicide (H)	12.02**	3.50 NS	0.55 NS	3.44 NS	4.12*
Light intensity (I)	1.57 NS	6.29**	9.82**	13.08**	20.46**
Harvest timing (T)	6.46**	92.78**	118.41**	137.92**	14.50**
H x I	3.34*	2.14 NS	0.55 NS	1.30 NS	1.33 NS
H x T	0.70 NS	0.63 NS	0.45 NS	0.31 NS	1.50 NS
I x T	0.73 NS	1.06 NS	2.96**	3.67**	0.34 NS
H x I x T	1.10 NS	1.01 NS	0.63 NS	0.68 NS	1.91 NS

NS = not significant. \* Significant at  $P \leq 0.05$ . \*\* Significant at  $P \leq 0.01$ .

## RESULTS AND DISCUSSION

### Absorption and translocation of imazethapyr in red rice

Herbicide by light intensity by harvest timing and the two-way interactions between these sources of variation were not significant for absorption and overall translocation of  $^{14}\text{C}$ -imazethapyr in red rice plants (Table 9). However, these two parameters were significantly affected by harvest timings and herbicide treatments. Absorption and translocation of  $^{14}\text{C}$ -imazethapyr increased slightly over time with less

than 15% of radioactive imazethapyr absorbed and less than 10% translocated at 168 HAT (Figure 5). Absorption and translocation of imazethapyr has not been studied in

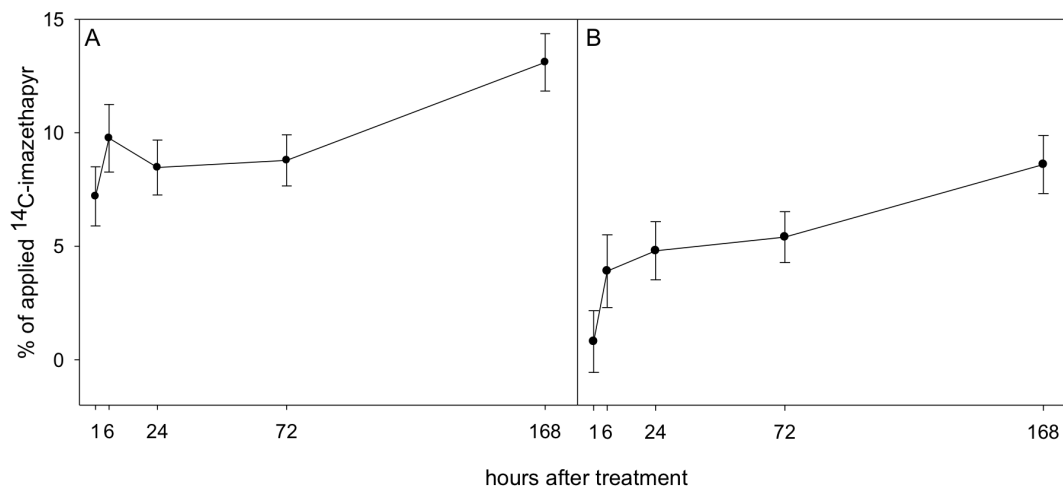

**Figure 5.** Imazethapyr absorption (A) and translocation (B) in red rice plants at 1, 6, 24, 72 and 168 hours after treatments. Data were averaged among herbicides and light intensity treatments. Bars represent 95% confidence intervals of 6 replications.

the TX4 red rice even though this ecotype has demonstrated more tolerance to imazethapyr as compared with other red rice accessions (Avila et al., 2005a; Gealy and Black, 1999). Limited absorption and translocation observed in this study by TX4 perhaps could explain its level of tolerance to imazethapyr. This hypothesis was considered in previous studies where TX4 presented slight tolerance to imazethapyr in a plant bioassay, but the ALS enzyme was sensitive to this herbicide suggesting differential metabolism, absorption or translocation (Avila et al., 2005a). No work was

found in the literature investigating uptake and movement of imazethapyr in red rice plants. However, in studies conducted using other grass species such as shattercane (*Sorghum bicolor* L.), giant foxtail (*Setaria faberi* Herrm.), and large crabgrass (*Digitaria sanguinalis* L.) approximately 80% of the  $^{14}\text{C}$ -imazethapyr applied with MSO was quantified inside the plants after 12 hours (Hart and Wax, 1996). This percentage was considerably higher than the 13% absorbed by TX4 after 168 hours (Figure 5A). From the amount of traceable imazethapyr applied on the red rice ecotype, 8.6% translocated throughout the plants after 168 hours (Figure 5B). This indicates that 66% of the absorbed  $^{14}\text{C}$ -herbicide moved away from the TL to other regions of the plant and consequently 44% remained storage on the spotted leaf.

Imazethapyr plus saflufenacil provided a higher uptake and translocation of  $^{14}\text{C}$ -imazethapyr than imazethapyr alone (Figure 6). Despite the low percentage of absorption and translocation observed on TX4, the combination of imazethapyr and saflufenacil increased the uptake (30%) and translocation (35%) in red rice plants when compared with imazethapyr alone. Greater movement of imazethapyr from the foliar surface into leaf cells provided the initial condition for higher mobility throughout the plant. These results may help explain observations obtained in the field where control of red rice was higher early in the season in treatments including saflufenacil than in treatments containing imazethapyr alone (Camargo et al., 2012). This would be indicative of a synergistic effect between the two herbicides. However, studies conducted to investigate the effects of saflufenacil on absorption and translocation of  $^{14}\text{C}$ -glyphosate indicated that uptake was not affected by the addition of saflufenacil, but



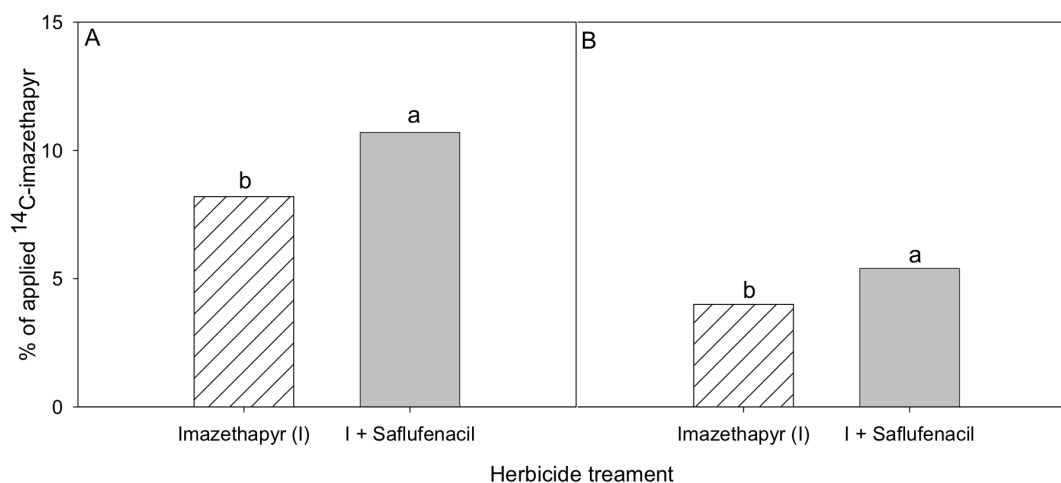
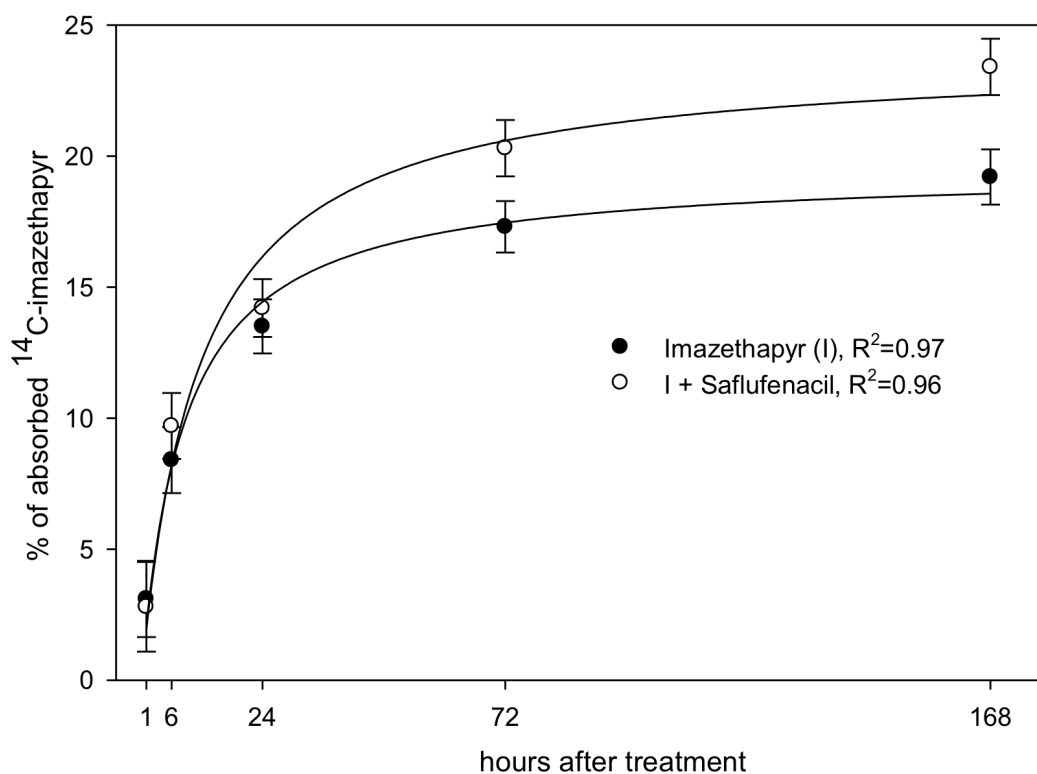

**Figure 6.** Imazethapyr absorption (A) and translocation (B) in red rice plants treated with imazethapyr alone or imazethapyr plus saflufenacil. Data were averaged among light intensity treatments and harvest timings. Letters represent significant differences according to Tukey's Test ( $p \leq 0.05$ ).

translocation of glyphosate was significantly reduced in horseweed (*Conyza canadensis*) plants (Eubank et al., 2010). Greater sensitivity of horseweed to saflufenacil resulting in more rapid necrosis of foliar tissues when compared with red rice may be related to the contrasting results on herbicide translocation in these two studies. The reasoning for higher foliar uptake of imazethapyr when combined with saflufenacil was not investigated on the TX4 ecotype. Uptake of imazethapyr into the leaves is normally rapid in plants (Senseman, 2007), but less than 10% was absorbed after 72 hours by TX4 ecotype. Conversely, saflufenacil results in rapid phytotoxicity in green tissues displaying necrosis and desiccation symptoms 2 to 3 hours after foliar application (Grossmann et al., 2011). Therefore, partial plant necrosis from saflufenacil in the TX4 ecotype resulting in peroxidation of cellular membranes could facilitate the movement of

imazethapyr from the epicuticular layer into the cytoplasm by opening pores/channels in the plasma membrane. No effects of light intensities were observed on absorption and translocation of imazethapyr in the TX4 ecotype.

An interaction between harvest times and herbicide treatments was observed for translocation of imazethapyr to the ATL section. No differences between the herbicide treatments were demonstrated due to overlapping 95% confidence intervals during the first 24 hours (Figure 7). Rapid upward movement of imazethapyr occurred within the first 24 hours period after herbicide application. One hour after treatment, 3% of the absorbed  $^{14}\text{C}$ -imazethapyr had moved out of the TL toward the upper region of the plant. After 24 hours, approximately 14% of absorbed imazethapyr had reached the ATL section. In the subsequent harvest times, a slower rate of translocation was observed toward the upper leaves. However, a higher percentage of  $^{14}\text{C}$ -imazethapyr was quantified at the ATL section at 72 and 168 hours in the treatment containing imazethapyr plus saflufenacil. At the last harvest, 19% of the absorbed imazethapyr was located ATL for the imazethapyr alone treatment compared with 23% in the combination treatment. Once again, these findings support field results that indicated a synergistic effect of saflufenacil on red rice control with imazethapyr in a CLEARFIELD<sup>®</sup> rice program (Camargo et al., 2012). It is important to reinforce that the red rice population from the field study was a mixture of red rice accessions and therefore not limited to the TX4 ecotype. As imazethapyr is a weak acid with translocation primary via phloem (Senseman, 2007), acropetal and basipetal movement of this herbicide would be expected within the plant.



**Figure 7.** Percentage of absorbed <sup>14</sup>C-Imazethapyr quantified above the treated leaf in red rice plants after herbicide application. Data were averaged among light intensities of 106, 259, 677, and 1066  $\mu\text{mol m}^{-2} \text{s}^{-1}$ . Bars represent 95% confidence interval of 6 replications. Regression equations for imazethapyr alone and imazethapyr plus saflufenacil are  $y = (19.49x)/(8.40+x)$  and  $y = (23.85x)/(11.41+x)$ , respectively.

Harvest time and light intensity affected translocation of imazethapyr to the BTL section. No differences among light intensities were observed 1 HAT with less than 10% quantified below the treated leaf (Figure 8). At 6 HAT more than 30% of the absorbed <sup>14</sup>C-imazethapyr was quantified in the two highest light intensities compared with 26% in the two lowest light intensities indicating faster basipetal movement of imazethapyr

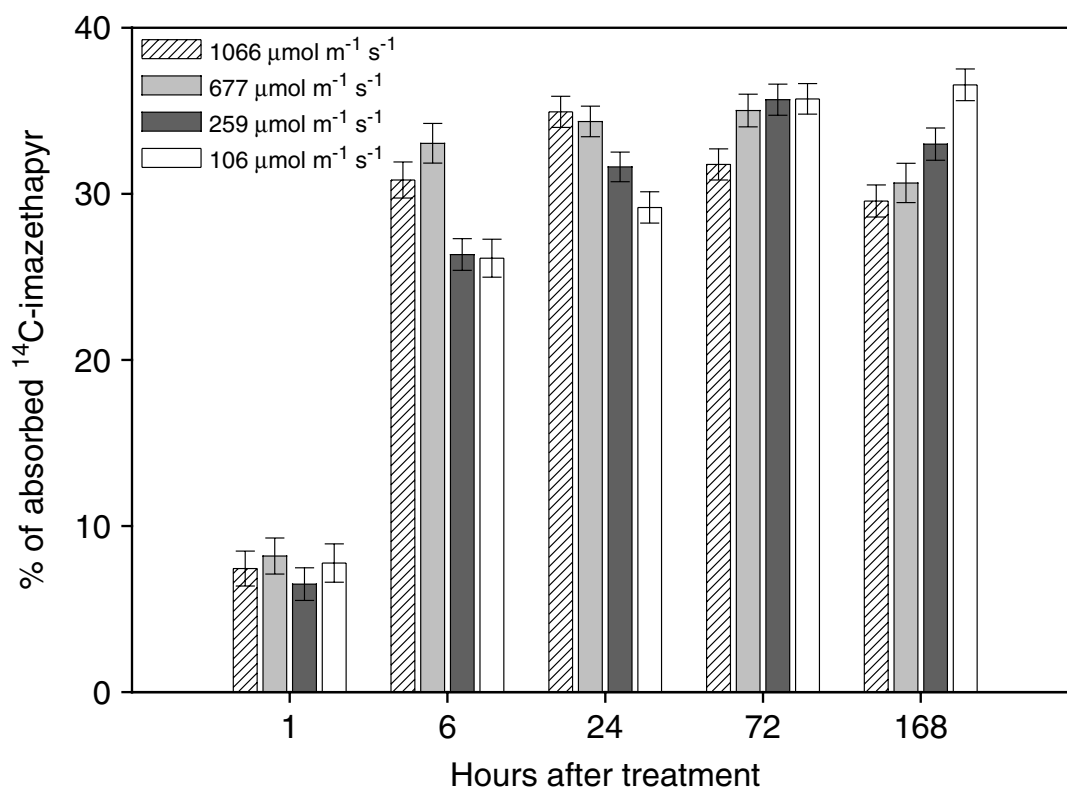

**Figure 8.** Percentage of absorbed  $^{14}\text{C}$ -Imazethapyr quantified in the aerial parts below the treated leaf in red rice plants after application of herbicide treatments. Data were averaged among herbicide treatments. Bars represent 95% confidence intervals of 6 replications.

under higher light availability. This trend continued on evaluations conducted 24 HAT where plants supplied with 677 and 1066  $\mu\text{mol m}^{-2} \text{s}^{-1}$  of light intensity reached the maximum of 35% of  $^{14}\text{C}$ -imazethapyr in below the treated leaf. In the plants treated with 106 and 259  $\mu\text{mol m}^{-2} \text{s}^{-1}$  the percentage of absorbed imazethapyr increased from the previous harvest time, however it was still lower than the two upper levels of light energy. A higher percentage was quantified in the 259  $\mu\text{mol m}^{-2} \text{s}^{-1}$  treatment than in the

106  $\mu\text{mol m}^{-2} \text{s}^{-1}$  after 24 hours. Basipetal translocation of imazamethabenz-methyl was also reduced at 120  $\mu\text{mol m}^{-2} \text{s}^{-1}$  when compared with 400  $\mu\text{mol m}^{-2} \text{s}^{-1}$  in a study conducted with wild oat (*Avena fatua* L.) (Xie et al., 1996). ALS inhibiting herbicides slowly control the weeds by blocking synthesis of leucine, isoleucine and valine in the branched chain amino acids pathway (Zhou et al., 2007). Therefore, the role of light energy on basipetal movement of imazethapyr could be associated with overall plant activity in the initial hours after herbicide application, specifically  $\text{CO}_2$  assimilation. Taiz and Zeiger (2002) illustrated a general photosynthesis light-response curve in a C3 plant where up to 300  $\mu\text{mol m}^{-2} \text{s}^{-1}$  rate of electron transport is limiting  $\text{CO}_2$  assimilation. This scenario was imposed in the two lowest light intensity treatments. Conversely, production of photoassimilates was not limited by energy supply in the two higher light intensity treatments. As assimilates could be synthesized in large quantities under higher light availability a more intense transport of assimilates via phloem would facilitate imazethapyr basipetal movement. In the two lowest light supplies maximum percentage of the  $^{14}\text{C}$ -imazethapyr was quantified 72 HAT. Results of similar magnitude were observed 2 days before under the highest light intensities. At 72 HAT, the percentage of  $^{14}\text{C}$ -imazethapyr started to decrease in the BTL section for the 1066  $\mu\text{mol m}^{-2} \text{s}^{-1}$  treatment. Amount quantified in the ABT section continued to diminish for plants harvested at 168 hours, especially in the treatments with the highest supply of light energy. This is a possible signal that imazethapyr translocated below the treated leaf is moving toward the roots.

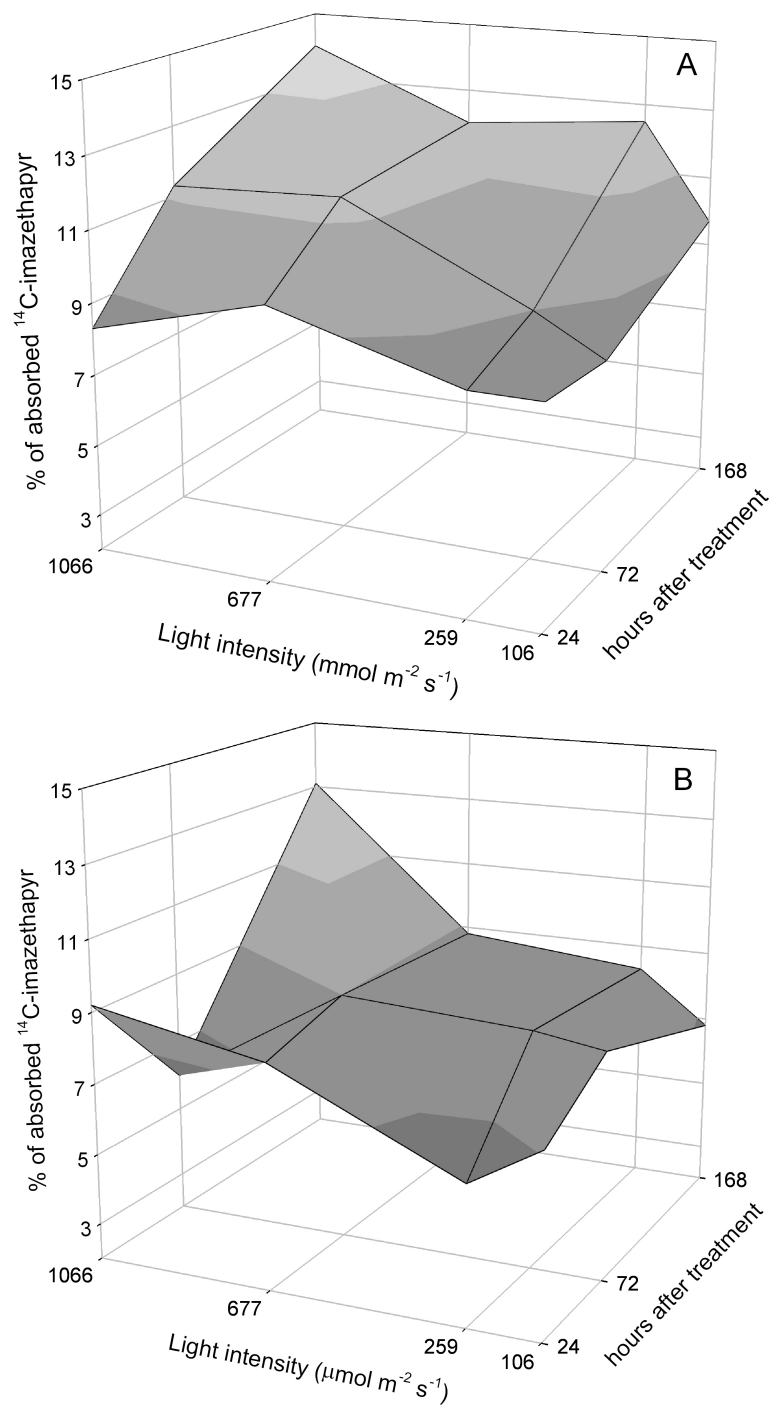

**Figure 9.** Percentage of absorbed  $^{14}\text{C}$ -Imazethapyr quantified in the root system of red rice plants after application of imazethapyr (A) and imazethapyr plus saflufenacil (B).

A three-way interaction was observed in the data collected for the root system. Due to the low radioactivity quantified in the samples collected in the first 12 HAT (data not shown), indicating low mobility of imazethapyr to the roots within this period, ANOVA was performed only in samples harvested 24, 72 and 168 HAT. Overall, the percentage of absorbed  $^{14}\text{C}$ -imazethapyr measured in the root system ranged from 5 to 15% (Figure 9). For both herbicide treatments, the highest percentage of  $^{14}\text{C}$ -imazethapyr quantified in roots was obtained at the last harvest time under the highest light intensity. This is consistent with the results obtained for below the treated leaf that demonstrated a reduction of imazethapyr from that section during the last harvest time especially for the highest light intensity treatments. Symptoms of ALS inhibitors would occur later in older leaves (Shaner and Singh, 1993) below the treated leaf due to the larger reserve of amino acids and proteins (Zhou et al., 2007). Therefore, the faster basipetal movement of imazethapyr that was initially observed below the treated leaf contributed to the quantification of approximately 14% of the absorbed herbicide in the roots after 168 hours under a higher light intensity regime. Both timing and light intensities were important factors for translocation of imazethapyr to the roots. Treatments receiving imazethapyr alone had a slightly higher percentage of imazethapyr quantified in the root system when compared with imazethapyr plus saflufenacil, especially under lower light intensity. However, when light intensity increased to  $1066 \mu\text{mol m}^{-2} \text{s}^{-1}$  and time was given to herbicide movement within the plant, differences diminished from herbicides treatments. Light intensity in a full-sunlight day can reach 1800 to 2000  $\mu\text{mol m}^{-2} \text{s}^{-1}$  while 200  $\mu\text{mol m}^{-2} \text{s}^{-1}$  are obtained on a cloudy day (Thompson and Nissen, 2002).

Although, red rice plants from the field study combining imazethapyr and saflufenacil (Camargo et al., 2012) were exposed to a night period and fluctuation in energy supply during the day, the treatment receiving the full light capability of the growth chamber approximates the field conditions.

### **Absorption and translocation of saflufenacil in hemp sesbania**

An interaction between herbicide treatments and light intensities was observed for absorption of  $^{14}\text{C}$ -saflufenacil in hemp sesbania (Table 10). Absorption of  $^{14}\text{C}$ -saflufenacil applied ranged from 40 to 60% among herbicide and light intensity treatments (Figure 10). With the exception of one light intensity treatment ( $677 \mu\text{mol m}^{-2} \text{s}^{-1}$ ), where the two-herbicide treatments provided around 50% of saflufenacil absorption, in all the remaining treatments, an effect of herbicide treatment was observed. Higher saflufenacil absorption was observed in the treatments receiving saflufenacil plus imazethapyr based on overlapping 95% confidence intervals. The interaction of herbicides increasing uptake of saflufenacil was observed in buckwheat (*Fagopyrum esculentum* Moench.) and cabbage (*Brassica oleracea* L.). Isolated cuticles of these plants displayed higher absorption of saflufenacil when in combination with glyphosate (Ashigh and Hall, 2010). In winter wheat, 2,4-D amine significantly increased absorption of saflufenacil while bentazon caused reduction in saflufenacil uptake (Frihauf et al., 2010a). In corn, the sodium salt of bentazon also reduced absorption of saflufenacil resulting in less injury (Moran et al., 2011). For the saflufenacil alone treatment, lower absorption was observed at lower light intensity (41%) that was



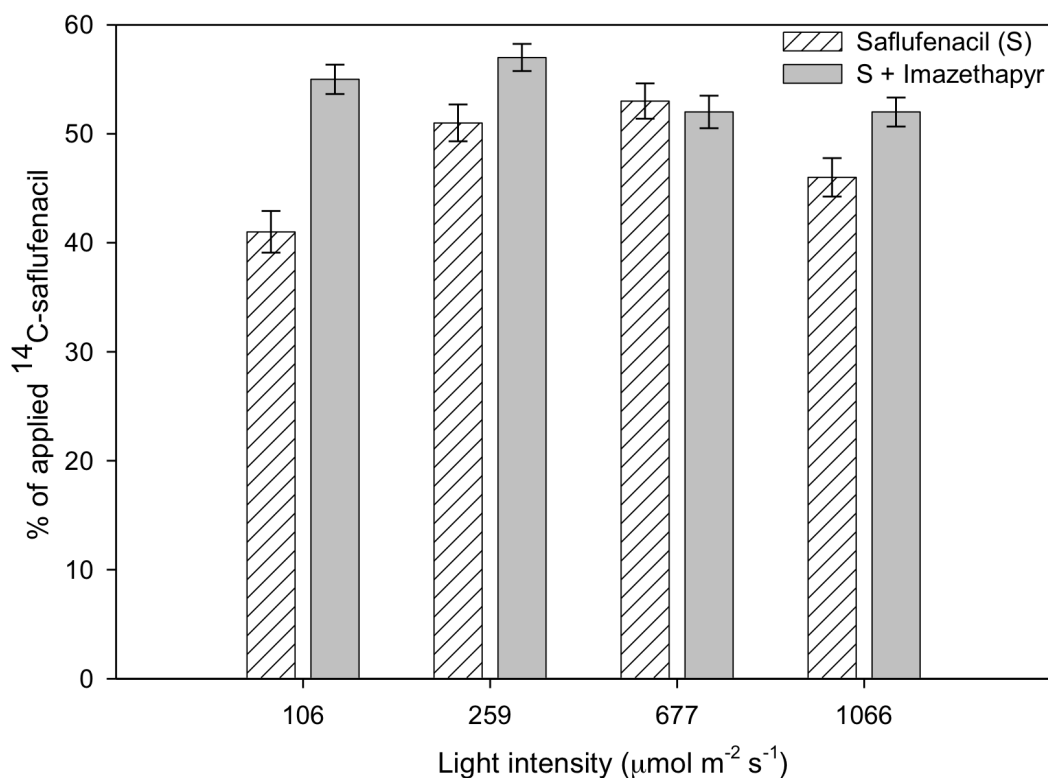
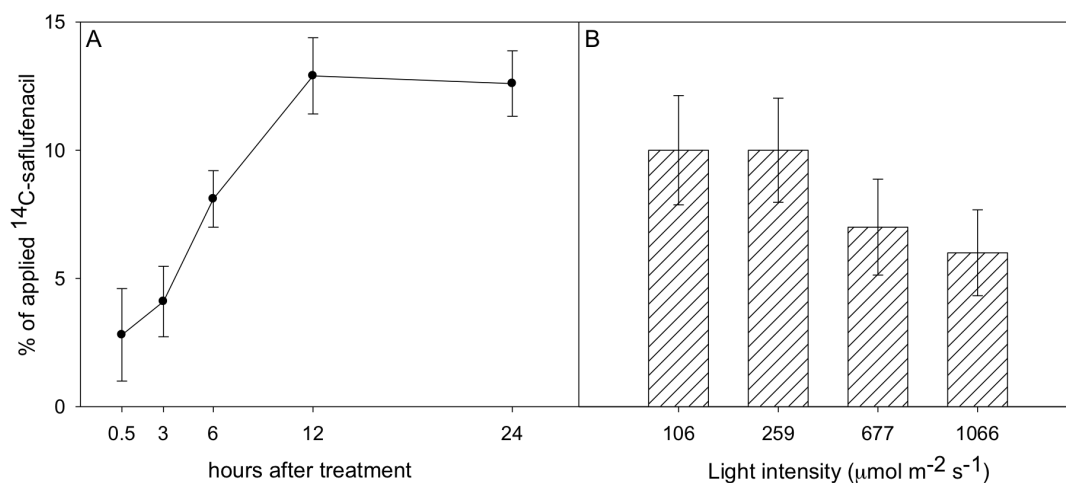

**Figure 10.** Saflufenacil absorption in hemp sesbania plants under four (4) light intensities conditions treated with saflufenacil alone or saflufenacil plus imazethapyr. Data were averaged among harvest times. Bars represent 95% confidence intervals of 6 replications.

followed up by the highest light intensity (46%). Treatments with intermediate intensity showed similar results providing more than 50% of saflufenacil absorption. Plants were grown under the same light intensity before application of treatments and therefore development of differential structures on the leaf surface (thicker epicuticular wax layer), as a function of the light treatment, would be unfeasible since all plants were harvested within a day after herbicide application. Currently, no work has been

conducted to investigate the effects of light intensities on absorption and translocation of saflufenacil. Grossman et al. (2011) studied light-grown plants and dark-grown seedlings of corn (*Zea mays* L.), black nightshade (*Solanum nigrum* L.) and tall morningglory (*Ipomoea purpurea* L.). For all plant species, under light intensity of  $70 \mu\text{mol m}^{-2} \text{s}^{-1}$ , approximately 80% of saflufenacil was absorbed 16 HAT. Dark-grown seedlings absorbed 55% of the applied  $^{14}\text{C}$ -saflufenacil after 24 HAT. However, plants received saflufenacil at different stages and thus convoluted comparison of results.

No interaction among treatments was indicated by ANOVA for results of saflufenacil translocation. However, translocation was affected by harvest times and light intensities. Translocation of  $^{14}\text{C}$ -saflufenacil rapidly increased within the first 12 HAT (Figure 11A). Translocation increased from 3 to 13% since the first harvest time at 0.5 HAT until 12 HAT. Translocation of saflufenacil has been studied in several weeds and crops. Grossman et al. (2011) observed that translocation varied from 3 to 7% in corn, black nightshade and tall morningglory after 16 hours. Saflufenacil translocation of 3.7% in corn (Moran et al., 2011), around 8% in wheat (Frihauf et al., 2010a), 5.8% in buckwheat, 6.1% in cabbage, 8.7% in canola (CL) and 6.0% in canola (RR) (Ashigh and Hall, 2010) was observed 24 HAT. In this study, no differences were observed from results collected at 12 and 24 HAT indicating that movement of saflufenacil away from the treated leaf to another region of hemp sesbania plants had stopped 12 HAT. Fast herbicide action causing membrane disruption of transport cells could have limited herbicide movement. Higher availability of light energy ( $1066 \mu\text{mol m}^{-2} \text{s}^{-1}$ ) resulted in lower translocation (6%) of the  $^{14}\text{C}$ -saflufenacil applied on the treated leaf when



**Figure 11.** Translocation of saflufenacil in hemp sesbania plants affected by harvest timing (A) and light intensity (B). Bars represent 95% confidence intervals of 6 replications.

compared with treatments receiving the lowest levels of light intensity (10%) (Figure 11B). The numerical difference from 10 to 6% could be considered irrelevant but because saflufenacil possesses limited translocation (Ashigh and Hall, 2010; Frihauf et al., 2010a; Grossmann et al., 2011; Moran et al., 2011), this difference represents a 40% reduction in translocation for the treatment receiving 1066  $\mu\text{mol m}^{-2} \text{s}^{-1}$  of light intensity. As saflufenacil is an effective herbicide for broadleaf control (Geier et al., 2009), the reduction in translocation under higher light intensity should not negatively affect its effectiveness in small broadleaf weeds. However, application when light intensity is reduced could potentially improve effectiveness of saflufenacil in larger broadleaf weeds.

An interaction was revealed between harvest times and light intensities for translocation of saflufenacil both above and below the treated leaf sections. No differences were observed for light intensity treatments until 3 HAT in these two plant sections (Figure 12). Translocation to the upward region of hemp sesbania plants increased as light intensity diminished at 6 HAT (Figure 12A) while no differences were observed below treated leaf (Figure 12B). At 12 and 24 HAT, 15 to 20% of the saflufenacil absorbed was quantified ATL on the two lower light intensity regimes while it remained around 10% on the two highest light intensities. Similar trends were observed BTL, however a lower proportion of absorbed  $^{14}\text{C}$ -saflufenacil moved basipetally in the hemp sesbania plants.

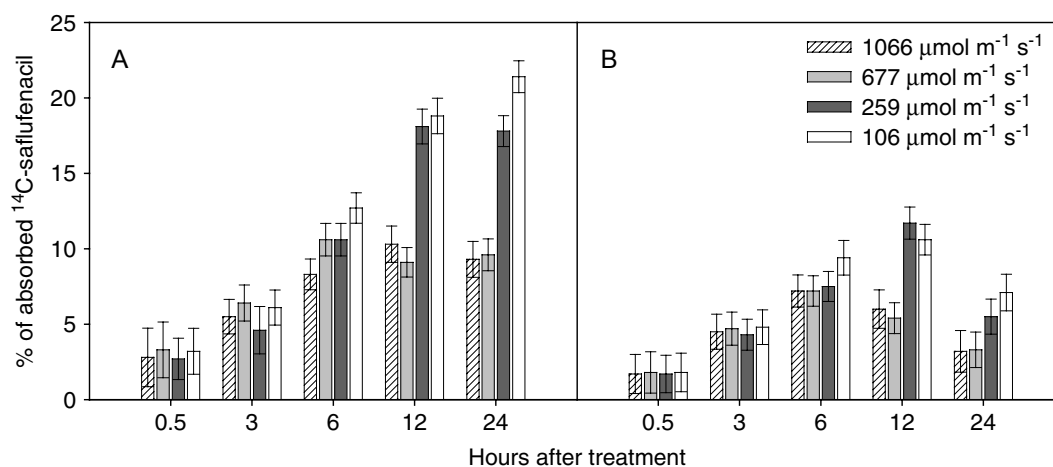

**Figure 12.** Percentage of absorbed  $^{14}\text{C}$ -saflufenacil quantified above the treated leaf (A) and aerial parts below the treated leaf (B) in hemp sesbania plants after herbicide application. Data were averaged among herbicide treatments. Bars represent confidence interval of 6 replications.

Lower light intensities increased the acropetal and basipetal distribution of saflufenacil in hemp sesbania plants. Slower action by saflufenacil under lower light conditions reducing the speed of foliar and vascular damage perhaps is the reason for the higher mobility of saflufenacil. Grossman et al. (2011) mentioned that high initial activity of saflufenacil potentially reduced translocation by damaging the vascular tissue. Systemic distribution of saflufenacil in plants had been demonstrated previously (Ashigh and Hall, 2010; Frihauf et al., 2010a; Grossmann et al., 2011; Moran et al., 2011). This is a novel characteristic within the group of PPO inhibitor herbicides and it is associated with saflufenacil being a weak acid that results in acropetal and basipetal distribution. ANOVA demonstrated the effect of all single sources of variation for distribution of saflufenacil to the roots (Table 10). Data were compiled for sampling conducted at 12 and 24 HAT due to the low radioactivity quantified in the previous sampling times. The proportion of saflufenacil increased from 1.8 to 4.4% of the amount absorbed as levels of light intensity decreased for results collected in the roots. This is in concordance with results obtained in above the treated leaf 12 and 24 HAT reinforcing the higher mobility of saflufenacil under lower light intensity.

## **CONCLUSIONS**

Saflufenacil enhanced absorption and overall translocation of imazethapyr in red rice plants independently of the tested light intensity treatment. Similarly, acropetal movement of imazethapyr was higher 3 and 7 days after treatment in the TX4 ecotype when applied with saflufenacil. These results support field observations of faster activity

of imazethapyr applied with saflufenacil in red rice plants (Camargo et al., 2012). Under higher light intensities, imazethapyr translocated faster below the treated leaf and root system indicating the effect of light intensity on basipetal movement of ALS inhibitors such as imazethapyr. Overall, imazethapyr improved absorption of saflufenacil in hemp sesbania, but uptake was dependent on light intensity treatments. Reducing light intensity resulted in greater translocation of saflufenacil in hemp sesbania. As a consequence, the two-lower light intensity treatments promoted greater acropetal and basipetal distribution of saflufenacil. Therefore, application of saflufenacil during cloudy days or late evenings could facilitate more thorough translocation through broadleaf weeds. Combination of saflufenacil and imazethapyr could provide a reciprocal benefit for the action of the two herbicides in TX4 red rice and hemp sesbania weeds.

**CHAPTER V**  
**DEGRADATION OF SAFLUFENACIL AS AFFECTED BY MOISTURE**  
**CONTENT AND SOIL CHARACTERISTICS**

**INTRODUCTION**

Saflufenacil is a new PPO inhibitor (Grossmann et al., 2010) that controls several broadleaf weed species as indicated in the approved label of Sharpen<sup>®</sup>. Sharpen<sup>®</sup> is an herbicide that has been recently registered for commercialization in the United States. Research conducted recently has demonstrated that saflufenacil can be safely used in preemergence applications with several winter and summer crops (Knezevic et al., 2010; Sikkema et al., 2008; Soltani et al., 2009; Soltani et al., 2010) justifying preemergence approval in multiple crops. Additionally, the herbicide is currently recommended in preplant burndown application programs providing an alternative for difficult to control and herbicide-resistant broadleaf weeds (Davis et al., 2010; Owen et al., 2011; Waggoner et al., 2011). The number of cases reporting resistance to glyphosate, the primary herbicide used for burndown applications, has increased considerably from 51 in 2005 to 138 in 2011 (WeedScience, 2012). In recent cases, broadleaf weeds such as Palmer amaranth (*Amaranthus palmeri*), common waterhemp (*Amaranthus tuberculatus*), and *Conyza* species account for a significant number of resistant weeds (WeedScience, 2012). Therefore, saflufenacil has potential to be widely used in combination with other burndown herbicides to help manage broadleaf resistance problems in production areas (Owen et al., 2011; Waggoner et al., 2011).

Additionally, a supplemental label for Sharpen<sup>®</sup> was approved during 2011 for preplant burndown applications in rice (CDMS, 2011). Studies investigating alternative usage patterns for saflufenacil had demonstrated that rice was consistently tolerant to preemergence applications (Camargo et al., 2011). Besides, saflufenacil had been effectively used to control hemp sesbania (*Sesbania exaltata*) in postemergence applications (Camargo et al., 2012; Meier et al., 2010) with potential to expand the weed control spectrum in combination with other rice herbicide programs (Camargo et al., 2011; Camargo et al., 2012). Despite these findings, saflufenacil is not recommended for preemergence application in rice and postemergence application in any row crop. Rice production differentiates from other major crops, as plants can be cultivated under flooding conditions (Das and Uchimiya, 2002). Therefore, saflufenacil behavior and fate in the soil have to be well understood considering the environmental aspects of the rice production ecosystem before this herbicide can be approved for further label expansion.

Saflufenacil has potential to be used in multiple agricultural systems. However, no work has been published in scientific journals investigating degradation and persistence of saflufenacil in soils, especially considering the flooded conditions similar to those found in an irrigated rice field. Degradation is one of the key processes affecting a pesticide's environmental impact (Villaverde et al., 2008). Dissipation patterns of a pesticide would be expected to change in lowland and upland environments. The soil profile in a lowland flooded rice paddy undergoes microbiological and chemical transformation (Liesack et al., 2000) that can affect degradation rates. For instance,



anaerobic microorganisms predominate in the soil community as oxygen is depleted after a flooding event in rice production (Liesack et al., 2000).

Since saflufenacil is a new herbicide that has demonstrated promise to be useful in a number of agricultural scenarios, it is important to have more data regarding environmental fate of this material. At the moment, results indicating saflufenacil dissipation in soils under different moisture conditions are not available. Information regarding saflufenacil degradation in soils from different geographic regions will provide information for more effective agronomic and environmental management practices. The objective of this study was to evaluate saflufenacil degradation and persistence as well as microbial activity in soils from different rice regions under field capacity (non-flooded) and saturated (flooded) conditions.

## **MATERIALS AND METHODS**

### **Soils**

Four samples were collected in rice producing areas of Texas (Eagle Lake and Beaumont) and Louisiana (Crowley and Gilbert) by sampling the top horizon of the soil (15-cm upper layer). Samples were brought to the laboratory, air-dried and then passed through a 2-mm sieve for removal of particles and non-decomposed plant residues. The prepared soil samples were stored at room temperature ( $24\text{ C} \pm 0.8$ ) during the conduction of the studies. A representative sub-sample was submitted to analysis at the Texas AgriLife Research and Extension Soil Characterization Laboratory located in College Station, TX. Particle size distribution, total organic carbon, pH and cation

exchange capacity results for the Nada, Morey, Crowley, and Gilbert soil series are presented on Table 11. Sand content, clay content, organic carbon and pH ranged from 6.4 to 56.8%, 9.6 to 45%, 0.8 to 3.5% and 5.3 to 7.8, respectively.

**Table 11.** Samples characterization for soils collected in Eagle Lake, TX (EL), Beaumont, TX (BM), Crowley, LA (CR), and Gilbert, LA (GB).<sup>a</sup>

Parameters	Soil sample locations			
	EL	BM	CR	GB
Soil series name	Nada	Morey	Crowley	Gilbert
Texture class <sup>b</sup>	FSL	L	SiL	SiC
Sand (%)	56.8	29.4	8.3	6.4
Silt (%)	33.6	46.5	77.3	48.6
Clay (%)	9.6	24.1	14.4	45.0
Organic carbon (%)	0.79	1.21	1.18	3.52
pH	6.5	7.8	5.7	5.3
CEC (Meq/100g)	6.9	26.3	12.2	44.2

<sup>a</sup>Samples were analyzed by Soil Characterization Laboratory located at Texas AgriLife Research and Extension, College Station, TX. <sup>b</sup>FSL, fine sandy loam; L, loam; SiL, silt loam and SiC, silty clay.

### Soil moisture treatments

A water retention curve was used to determine the amount of water to be added in the field capacity and saturated treatments. A sample of each soil was placed inside of

a ring that had been positioned over a suction plate. Water was applied on the plate and samples were allowed to saturate. The chamber containing the suction plate was sealed and negative pressure (-33 kPa) was applied to estimate the field capacity moisture (Lee et al., 2004). Water content for the saturated treatment was determined by applying no pressure (0 kPa) on the plate. After 24 hours, samples were removed from the suction plate and weighed on a precision balance to acquire the wet weight. Subsequently, samples were oven-dried at 105 C for 48 hours to obtain the dry weight. For each soil sample and water potential, the gravimetric water content ( $\theta_g$ ) was calculated using the following equation.

$$(1) \quad \theta_g = \frac{(\text{wet soil weight} - \text{dry soil weight})}{\text{dry soil weight}}$$

Results in g water g soil<sup>-1</sup> are listed in Table 12. The amount of water to generate the moisture treatments was calculated depending on the soil sample size (g).

### **Saflufenacil degradation**

Air-dried samples of each soil (10 g) were placed in a round-bottom centrifuge tube, re-wetted to re-establish microbial activity, and pre-incubated in the dark for 14 days prior to herbicide and moisture treatment applications. All samples were re-wetted to bring the soil moisture to 50% of the field capacity using distilled water. Amount of saflufenacil to be added in the samples ( $\mu\text{g g soil}^{-1}$ ) was estimated using the assumption that a 15-cm furrow slice in the area of a hectare would have approximately 2250 t of soil. Additionally, it was assumed that the herbicides would be mainly concentrated in a

**Table 12.** Gravimetric water content ( $\theta_g$ ) estimated using -33 kPa (field capacity) and 0 kPa (saturation) as the water potential of the soil samples.

Soil series	Soil moisture treatments <sup>a</sup>	
	Field capacity (-33 kPa)	Saturation (0 kPa)
	mg water g soil <sup>-1</sup>	
Nada	159	363
Morey	264	523
Crowley	326	614
Gilbert	415	807

<sup>a</sup>Based on the water retention curve determination. Samples were replicated 4 times.

5-cm layer (750 t of soil). Saflufenacil was applied in pre-incubated samples at the rate of 2000 g ha<sup>-1</sup>, therefore, corresponding to 2.67  $\mu\text{g g soil}^{-1}$ . The herbicide rate was higher than the maximum recommended amount to be applied in a cropping season according to the Sharpen<sup>®</sup> registration label. A higher rate of saflufenacil was chosen to allow quantification analysis with the employed analytical instrumentation. Preliminary quality control assurance indicated no residual of saflufenacil in the soil samples.

Analytical standard of saflufenacil (99.5% purity) was provided by BASF Corporation (Research Triangle Park, NC). Stock solution was prepared dissolving saflufenacil in a high performance liquid chromatograph (HPLC) grade acetonitrile. Stock solution was kept under refrigeration (~3 C) for storage. Solution containing saflufenacil was pipetted and thoroughly mixed with the pre-incubated soil samples, inside the centrifuge tubes, before adding the water treatments. The amount of water

added in the field capacity and saturation treatments was calculated using results described in the Table 12 considering a 10-g sample size. As all samples were re-wetted to bring moisture to 50% of field capacity during the pre-incubation step, only the remaining amount to achieve the field capacity and saturation moisture content was added during sample preparation prior to incubation. However, in the saturated treatments, an extra 1.5 mL of distilled water was added to generate an aqueous layer, simulating a flooded rice paddy. Tubes were then loosely capped and incubated at 24.8 C ( $\pm 0.5$ ) in the dark. Moisture content was adjusted twice a week by replenishing the water amount lost, if any, after weighing the pre-incubated and incubated tubes. Upon experiment initiation, samples were removed at 0, 1, 3, 7, 14, 21, 30, and 45 days. The 0-day samples were used to estimate extraction efficiency. In these samples, herbicide was added and mixed with air-dried soil (without pre-incubation) 24 hours before extraction to allow equilibration (Lancaster et al., 2007). Moisture treatments were applied immediately prior to the extraction. Experimental samples were prepared starting from the longest incubation time and the remaining timings were planned such that all samples of one replication were harvested in the same date. Harvested samples were immediately frozen. Replications were staggered over time during the conduction of the experiment such that replications could be extracted on separate days.

### **Soil extraction procedure and analysis**

An accelerated solvent extraction (ASE) method was developed based on Lancaster et al. (2007) to extract saflufenacil from soil samples. Centrifuge tubes

containing samples were removed from the freezer and placed in a water bath (~ 40 C) for 5 to 10 min to initiate the defrosting process. Subsequently, 2 and 4 g of Hydromatrix<sup>®</sup> (inert diatomaceous earth, Agilent Technologies Inc., Santa Clara, CA) were combined with field capacity and saturated soil sample treatments, respectively. Hydromatrix<sup>®</sup> facilitated removal of samples from the centrifuge tubes by absorbing the moisture. Incubated samples mixed with Hydromatrix<sup>®</sup> were then transferred into the ASE extraction cells (22-mL) assembled with a glass fiber filter at the bottom. Empty spaces at the top of the cells were filled with washed sand until the cell volume reached capacity (Ottawa sand, EMD Chemicals Inc., Gibbstown, NJ). The ASE method (ASE 200, Dionex Corporation, Sunnyvale, CA) consisted of using acetonitrile as solvent, 3 static cycles of 5 min each, and 10.3 MPa of cell pressure. The instrument oven was set to perform the extraction at 50 C. The extraction cells were pre-heated for 2 min before being filled up with acetonitrile. Subsequently, the cell was heated and pressurized for 5 min to achieve thermal equilibrium. Immediately after the static cycles were initiated where pressure and temperature were maintained at the desire specifications during the 5 min. At the end of each static cycle the cell was partially flushed and fresh solvent corresponding to 60% of the cell volume was introduced into the samples at the end of all cycles. Finally, solvent was purged from the cell by a stream of N<sub>2</sub> gas for 60 s and discharged into the collection vial.

One gram of sodium chloride was added in the collection vials containing the extraction solution. The vial was then manually shaken for 1 min. The organic and aqueous phases were allowed to separate for 15 min (Schenck et al., 2002). The upper

layer (organic) was transferred to a graduated tube while the aqueous layer was transferred to a waste container. The organic phase was evaporated using a water bath temperature of 50 C and vortexing force generated by nitrogen gas flowing directly in the sample tube (TurboVap<sup>®</sup> LV Evaporator, Zymark Center, Hopkinton, MA). Samples were evaporated to concentrate saflufenacil in solution and facilitate quantitative analysis. The final volume was measured in the graduated tube and it ranged from 1 to 4 mL depending on the incubation time. An aliquot of the final volume was removed and placed in HPLC vial for analysis.

Extractions from soil were analyzed using a HPLC equipped with a photodiode array detector (Waters Corporation, Milford, MA). A method was developed using a Symmetry<sup>®</sup> C18 analytical column (5  $\mu\text{m}$ , 4.6 mm x 250 mm). An isocratic mobile-phase was prepared using 65% acetonitrile, 34.5% deionized water and 0.5% formic acid. Mobile phase was filtered with a 0.45- $\mu\text{m}$  filter and degassed before usage. Samples were analyzed for 10 min using a flow rate of 1 mL min<sup>-1</sup>. The sample injection volume was 20  $\mu\text{L}$ . The retention time for saflufenacil was 5.95 min ( $\pm 0.05$ ). Samples were analyzed at 271 nm. Calibration standards were prepared in acetonitrile at 1, 2, 5, 10, and 15  $\mu\text{g mL}^{-1}$ . These concentrations encompass the expected range of responses in the final sample aliquots. The R<sup>2</sup> for the calibration curves prepared during the study was above 0.998. Calibration standards were included in every analyzed sample set.

### **Carbon dioxide (CO<sub>2</sub>) evolution under saturation and field capacity soil moisture**

Microbial CO<sub>2</sub> evolution was determined hourly for 30 days by adapting the procedure described previously in the literature (Lancaster et al., 2008). Samples (30 g) were pre-incubated after re-wetting the air-dried soil to bring moisture to 50% of field capacity. After 14 days of pre-incubation, samples were treated with saflufenacil (2.67 µg g soil<sup>-1</sup>) using stock solution and the procedure previously detailed. Soil samples for the field capacity treatments were placed in 50-mL plastic beakers containing holes in the bottom. Soil was added over a filter paper that covered the beaker holes. Beakers were then placed inside a chamber and the remaining amount of water to achieve the field capacity moisture content was added in each soil. Besides, 10 mL of water was added on the chamber to allow bottom-up soil rewetting during the course of the experiment. Samples for the saturation treatments were placed in a glass beaker inside the chamber. Water was added to achieve saturation based on results of Table 12. Furthermore, 4.5 mL of water was added in each soil to create an aqueous layer simulating a rice field. Samples were incubated at 24.0 C (± 0.8).

Sealed chambers were coupled with an infrared CO<sub>2</sub> detector (ADC 225MK3, BioScientific Ltd., Great Amwell, England) allowing continuous reading of carbon mineralization. The apparatus used to conduct the study had the capability of analyzing 10 samples at once. Soda lime color indicator was used to remove CO<sub>2</sub> from the air before getting into the system (Figure 13). Subsequently, air flowed into the instrument and reset was initiated to assure zero reading of CO<sub>2</sub> before reaching the chambers. This procedure was conducted before initiating the experiments and during experiment



performance when air was bypassing the system. Also, a tank containing a known concentration of  $\text{CO}_2$  was used to calibrate instrument readings. A solenoid switch controlled the opening and closing of the chamber. Every 4 min a chamber was opened and  $\text{CO}_2$  that had accumulated during the hour was flushed out. A data logger recorded the highest value observed within the 4-min period. Subsequently, the process was repeated in all 10 chambers. A 20-min bypass occurred at the end of the hour. Results stored in the data logger were periodically transferred into the computer that was used to run the software controlling the apparatus operation.

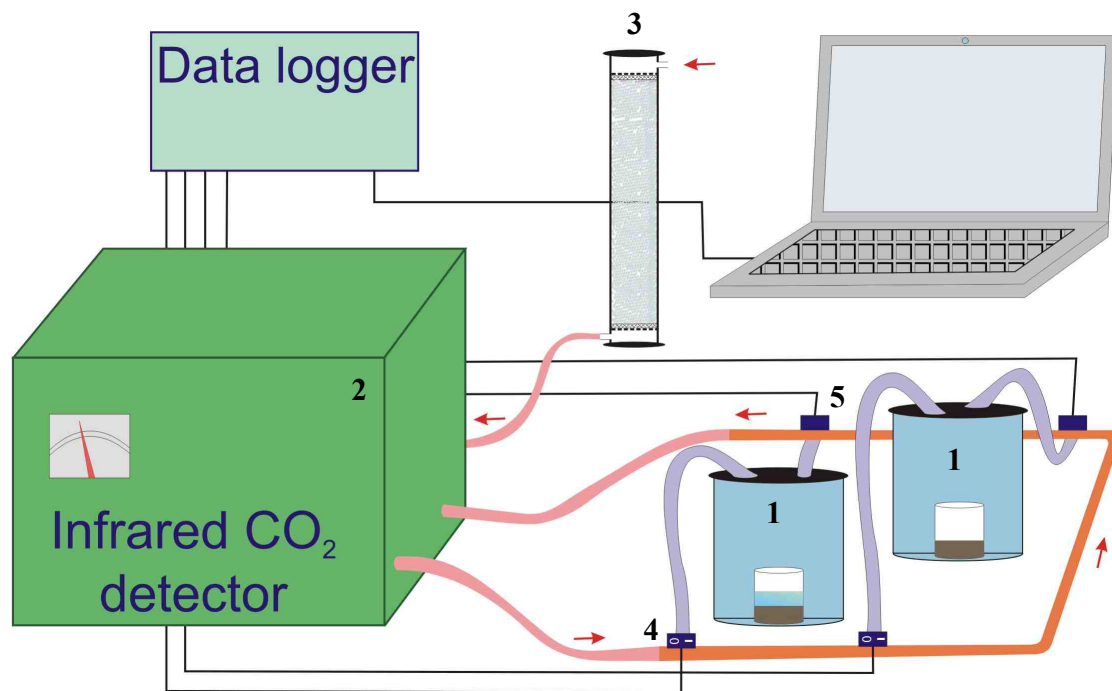

**Figure 13.** Schematic representation of apparatus used to quantify microbial respiration. Sealed chambers containing combination of soil by water treatments (1) were coupled with an infrared  $\text{CO}_2$  detector (2). Arrows represent the air system flow. Soda lime reservoir (3), solenoid switch (4=in; 5=out).

### **Statistical analysis**

The studies were conducted as a randomized complete block design. Treatments formed by the combination of soils and moisture contents were repeated in time. Carbon mineralization and saflufenacil degradation studies were conducted using four and five replications, respectively. SAS<sup>®</sup> Enterprise Guide<sup>®</sup> (Statistical Analysis Systems, 4.2 Software, SAS Institute Inc., Cary, NC) was used to perform the regression analysis on cumulative carbon mineralization and first-order degradation. Validity of the models was verified by assessing the normality of the errors and homogeneity of the variance using the software. Concentration of saflufenacil over time was divided by the initial concentration and logarithmic transformed before adjusting the first-order equations. Means of remaining parameters were separated by overlapping 95% confidence intervals.

## **RESULTS AND DISCUSSION**

### **CO<sub>2</sub> mineralization under saturated and field capacity moisture conditions**

Microbial activity measured by production of CO<sub>2</sub> was assessed in contrasting moisture conditions. Under saturated conditions, CO<sub>2</sub> production was relatively constant throughout the study where mineralization rates remained below 3 mg C kg soil<sup>-1</sup> hour<sup>-1</sup> (Figure 14A). Hourly carbon mineralization was higher under field capacity conditions for all soils within the initial 500 hours after treatment. Microbial activity rapidly increased in the field capacity treatments indicating that pre-incubation procedures were effective in reactivating the soil microorganisms. Maximum rates of carbon

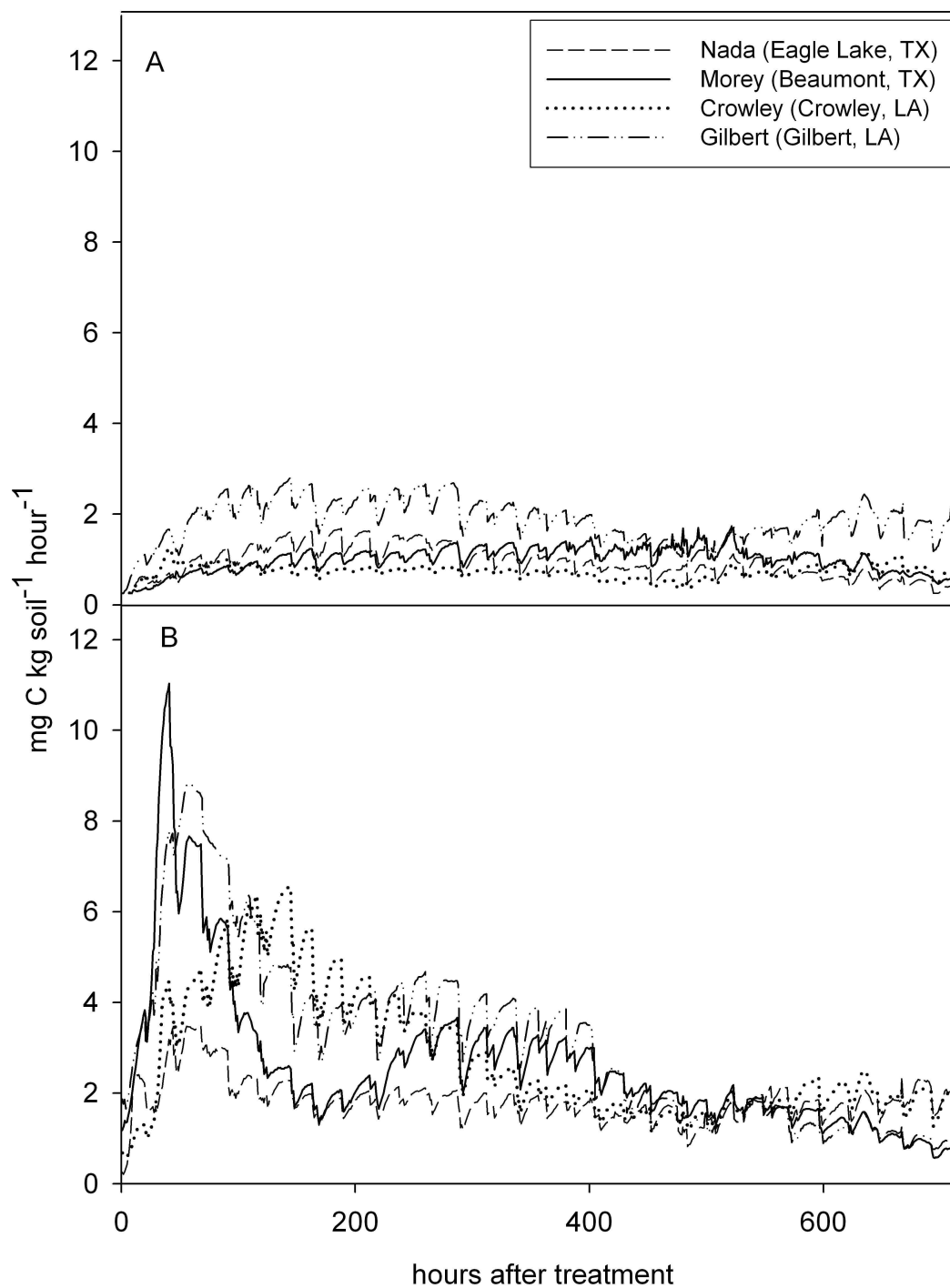

**Figure 14.** Carbon evolution in rice soils under saturated (A) and field capacity (B) moisture conditions during 716 hours (~30 days). Saflufenacil was applied at  $2000 \text{ g ha}^{-1}$  ( $2.67 \text{ } \mu\text{g g soil}^{-1}$ ). Results are average of four replications.

mineralization were observed within the first 100 hours (~ 4 days) after incubation for all soils, except for the Crowley series where the maximum was observed at approximately 140 hours (~ 6 days) after treatment (Figure 14B). Maximum mineralization rates ranged from approximately 3.5 to 11 mg C kg soil<sup>-1</sup> hour<sup>-1</sup> depending on the soil. Carbon dioxide production returned to basal respiration levels between 425 to 475 hours after incubation. In a similar experiment using fluometuron, CO<sub>2</sub> production returned to basal respiration levels after 450 hours (Lancaster et al., 2008). Daily cycles of carbon mineralization were observed under both moisture regimes. These cycles can be associated with fluctuations in room temperature that ranged from 23.3 to 24.8 C.

Carbon dioxide can be produced by various forms of microbial metabolism such as fermentation (Dodla et al., 2009), anaerobic respiration (Hong and Gu, 2009; Lovley and Coates, 2000), and aerobic respiration (Dettling et al., 2006). Soil flooding rapidly depletes oxygen from the soil environment by aerobic bacterial consumption and chemical oxidation reactions (Liesack et al., 2000). Therefore, the microbial community would shift to anaerobic with prevalence of fermentative bacteria and methanogenic archaea microorganisms after flooding (Liesack et al., 2000). Consequently, under these circumstances, anaerobic respiration and fermentation would potentially lead to production of CO<sub>2</sub> and methane (Liesack et al., 2000). As fermentation results in partial degradation of organic skeletons, less CO<sub>2</sub> can be generated with this metabolic process. Anaerobic respiration would result in complete oxidization of organic molecules, but it requires the presence of alternative electron acceptors (Dettling et al., 2006; Dodla et al., 2009; Lovley and Coates, 2000). Therefore, CO<sub>2</sub> evolution results indicated a shift in

microbial population between the moisture treatments. Aerobic respiration would predominate in the field capacity treatments while anaerobic degradation of organic carbon would be the metabolic processes acting under saturated conditions.

These observations are reinforced by the cumulative carbon mineralization adjusted using polynomial regressions previously described by Lancaster et al. (2008). Cumulative carbon mineralization was 1.5 to 7.2-fold greater with soil under field capacity as compared to saturated conditions based on regression linear slopes. This indicates great oxidation of organic compounds to the less reduced form ( $\text{CO}_2$ ) when oxygen is not limiting aerobic activity of microorganisms. Under saturated conditions Nada, Morey and Crowley soils demonstrated relatively similar patterns for cumulative carbon mineralization, while Gilbert displayed higher mineralization as indicated by a steeper slope (Figure 15A). Differences among soils were more evident at field capacity. Microbial activity in the Gilbert series resulted in mineralization approaching  $2000 \text{ mg C kg soil}^{-1}$  at the end of the experimental period (Figure 15B). Morey and Crowley displayed intermediate carbon mineralization curves while Nada had the lower slope reaching over a  $1000 \text{ mg C kg soil}^{-1}$  after approximately 30 days. Carbon mineralization is associated with the availability of organic carbon for the field capacity treatments as greater accumulation occurred in the soil with the higher content (Gilbert). Moreover, smaller accumulation was observed in the soil with the lower organic carbon percentage (Nada).

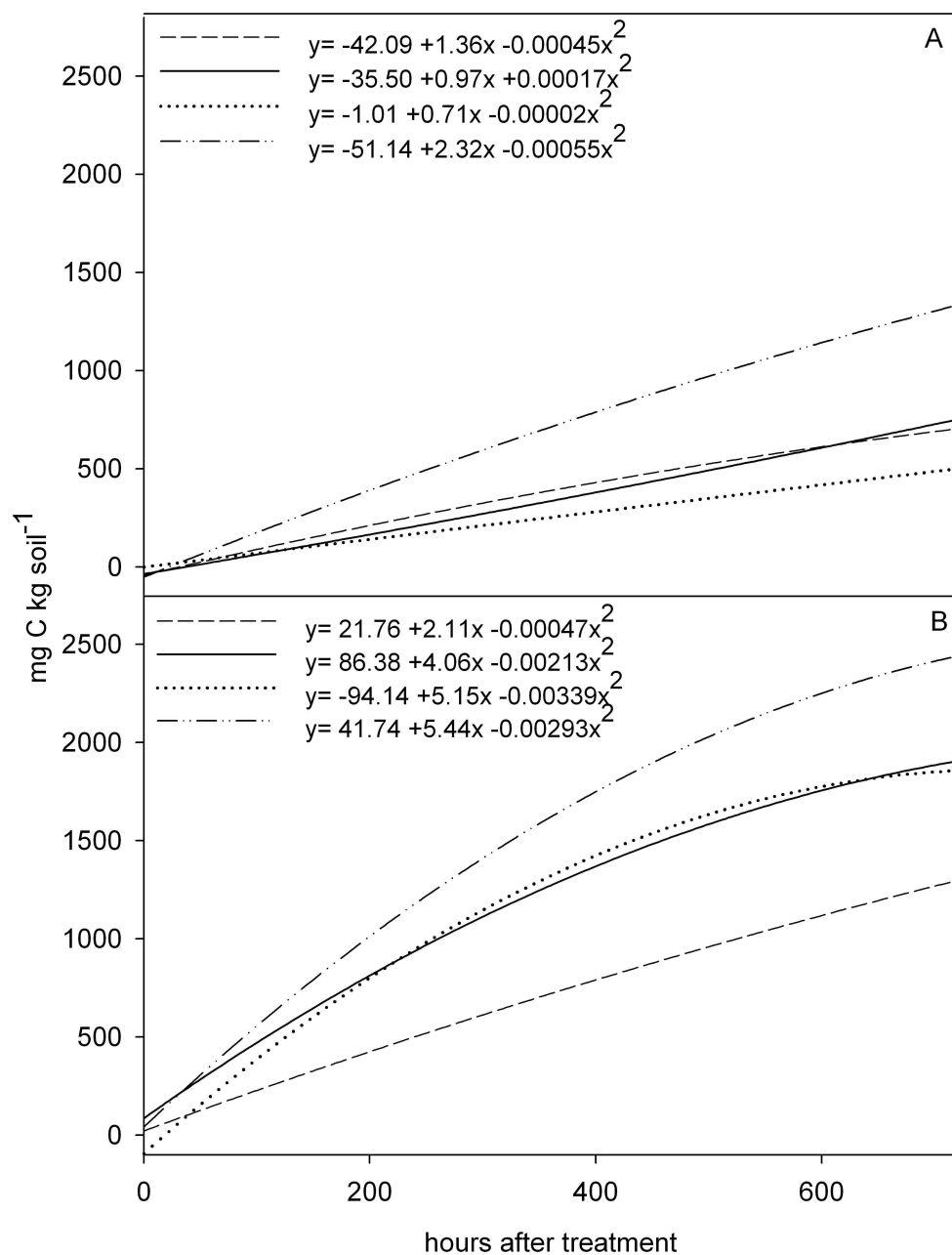

**Figure 15.** Fitted equations for cumulative carbon mineralization at Nada (---), Morey (—), Crowley (···), and Gilbert (·-·-·) rice soils under saturation (A) and field capacity (B) moisture conditions. Saflufenacil was applied at 2000 g ha<sup>-1</sup> (2.67 μg g soil<sup>-1</sup>).

### Saflufenacil extraction efficiency

Accelerated solvent extraction (ASE) is a technique that has been successfully used on a distinct array of matrices for extraction of organic molecules (Ding et al., 2011; Gentili et al., 2004; Hossain et al., 2011; Lancaster et al., 2007). Currently there is no published method to extract saflufenacil from soil samples. Methodology developed to conduct this study resulted in recovery superior than 80% for a combination of soils and moisture conditions (Figure 16).

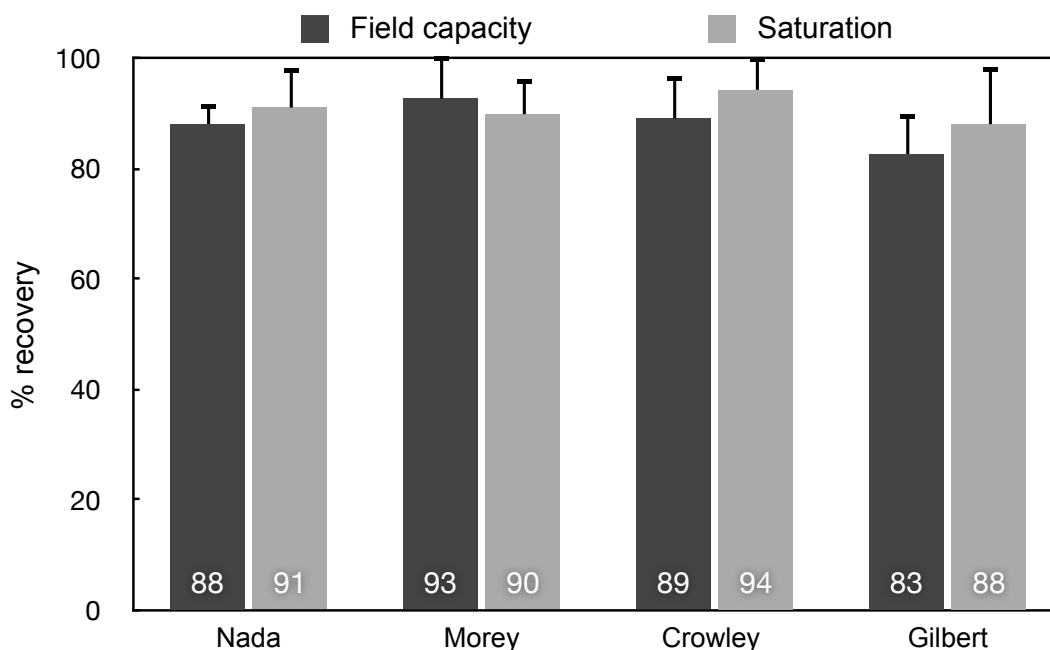

**Figure 16.** Saflufenacil recovery from soil samples used to control efficiency of accelerated solvent extraction (ASE) method (50 C, 10.3 MPa, acetonitrile, 3 static cycles). Bars represent positive side of 95% confidence intervals of 5 replications.

No differences among treatments were observed by overlapping 95% confidence intervals. Therefore, the ASE procedure demonstrated to be an effective method for extracting saflufenacil from a range of soil matrices with a relatively low volume of solvent. This procedure could be employed in future studies that required extraction of saflufenacil from soil samples of different moisture content.

### **Saflufenacil degradation**

Overall concentration of saflufenacil decreased more rapidly at field capacity than at saturation. Differences between moisture treatments were observed 7 days after treatment in Morey and Gilbert soils and 14 days after incubation in the Crowley soil (Figure 17). However, differences in saflufenacil concentration persisted only until 21 days after treatment in the Morey series. The only difference observed in the Nada soil was at 30 days after incubation. Therefore, no differences between moisture treatments within each soil were observed at 1 and 3 days after incubation. The maximum rate of microbial activity was observed from 4 to 6 days after incubation when soils were kept at field capacity. Therefore, differences in saflufenacil concentration between soil moisture treatments were perceived after observation of maximum carbon mineralization, indicating the importance of microbial activity on saflufenacil degradation.



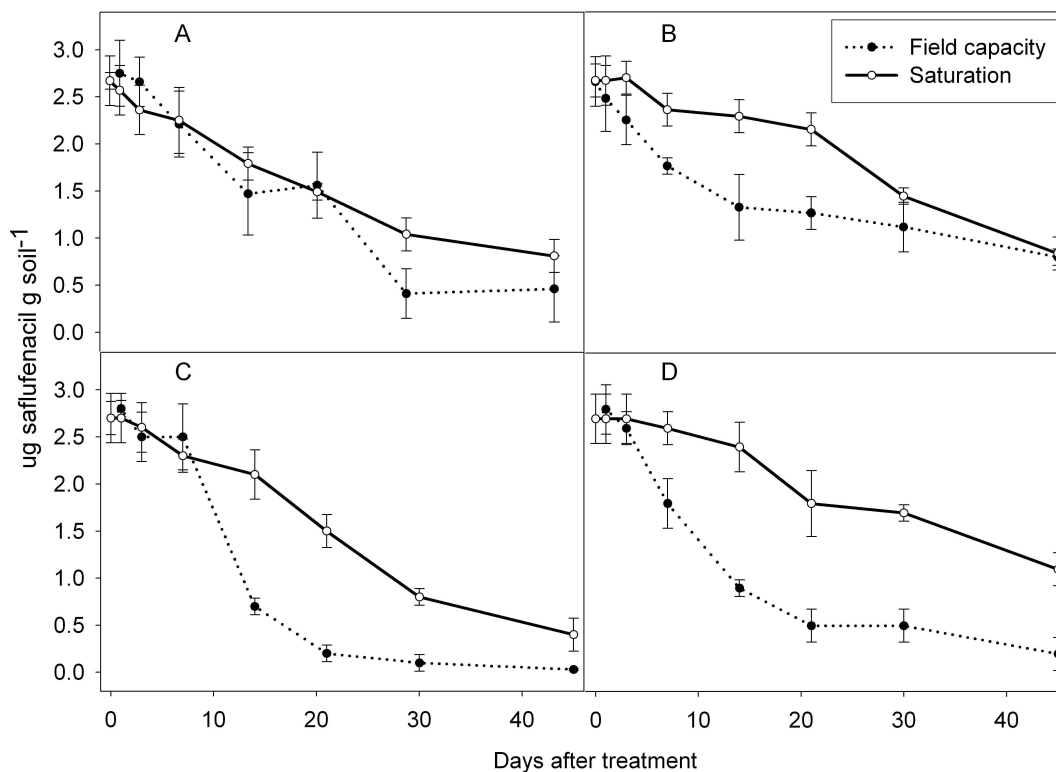

**Figure 17.** Patterns of saflufenacil degradation under saturation and field capacity moisture conditions for Nada (A), Morey (B), Crowley (C), and Gilbert (D) soil series. Saflufenacil was applied at  $2000 \text{ g ha}^{-1}$  ( $2.67 \mu\text{g g soil}^{-1}$ ). Bars represent 95% confidence intervals of five replications.

Saflufenacil dissipation patterns were subsequently linearized by logarithmic transformation to estimate degradation rates (Figure 18). Saflufenacil concentration 1 day after incubation was not different than the concentration at experimental initiation. However, significantly less saflufenacil was observed 3 days after incubation when compared with 0 days (data not shown). Thus, a 1-day period was defined as the lag phase. First-order regressions for all soils and moisture treatments were fit starting at 1 day after incubation and resulting parameters were listed in Table 13.

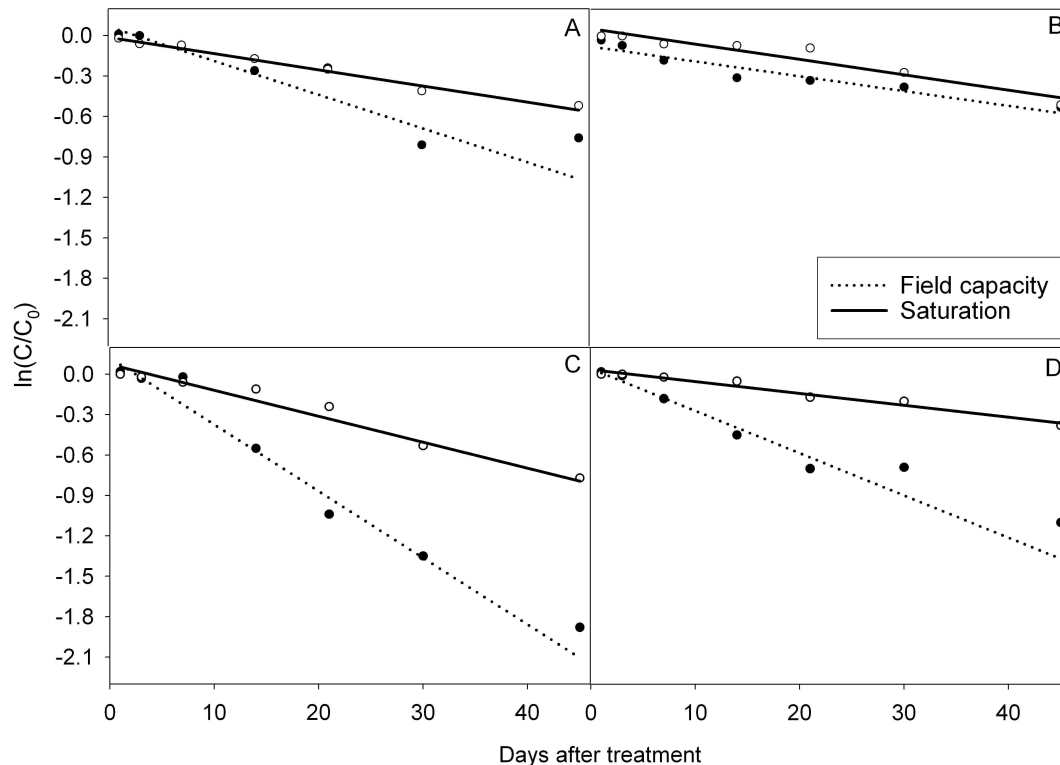

**Figure 18.** First-order degradation rate of saflufenacil under saturation and field capacity moisture conditions for Nada (A), Morey (B), Crowley (C), and Gilbert (D) soil series. Saflufenacil was applied at  $2000 \text{ g ha}^{-1}$  ( $2.67 \mu\text{g g soil}^{-1}$ ). Estimated parameters of polynomial equations are listed in the Table 13.

Saflufenacil degradation was faster at field capacity for all soils, except for Morey soil (Table 14). Herbicide half-life was 2.1, 2.5, and 3.4 times shorter under field capacity treatments for Nada, Crowley, and Gilbert soils, respectively. Saflufenacil half-life was similar for moisture treatments in the Morey soil. Half-life averaged among soils was 59 and 33 days for saturated and field capacity treatments, respectively.

**Table 13.** Parameters for first-order degradation rates of saflufenacil under saturation and field capacity soil conditions.<sup>a</sup>

Soil moisture	Soil	Intercept	Linear parameter
Saturation	Nada	[-0.0500, <b>-0.0121</b> , 0.0258] <sup>b</sup>	[-0.0136, <b>-0.0120</b> , -0.0103]
	Morey	[0.0188, <b>0.0551</b> , 0.0914]	[-0.0130, <b>-0.0114</b> , -0.0098]
	Crowley	[0.0104, <b>0.0745</b> , 0.1386]	[-0.0221, <b>-0.0193</b> , -0.0165]
	Gilbert	[0.0027, <b>0.0347</b> , 0.0668]	[-0.0103, <b>-0.0088</b> , -0.0074]
Field capacity	Nada	[-0.1094, <b>0.0664</b> , 0.2423]	[-0.0328, <b>-0.0251</b> , -0.0173]
	Morey	[-0.1292, <b>-0.0787</b> , -0.0283]	[-0.0132, <b>-0.0110</b> , -0.0087]
	Crowley	[-0.0154, <b>0.1208</b> , 0.2570]	[-0.0557, <b>-0.0495</b> , -0.0433]
	Gilbert	[-0.0918, <b>0.0427</b> , 0.1772]	[-0.0376, <b>-0.0314</b> , -0.0252]

<sup>a</sup>Parameters of polynomial equation:  $y = \beta_0 + \beta_1 x$ ;  $\beta_0$  = intercept,  $\beta_1$  = linear. Saflufenacil was applied at 2000 g ha<sup>-1</sup> (2.67  $\mu\text{g g soil}^{-1}$ ). <sup>b</sup>Estimated parameters (center, bold) with lower (left) and upper (right) 95% confidence limits.

Pesticides are degraded by biological, chemical and photochemical process (Villaverde et al., 2008). In these experiments, saflufenacil degradation resulted from chemical and biological degradation as samples were incubated in the dark. Microbiology activity depended on soil moisture as previously indicated by carbon mineralization results. Predominance of aerobic respiration resulted in faster dissipation of saflufenacil at field capacity in most of the soil series. Conversely, anaerobic metabolism resulted in slower degradation of saflufenacil under the saturated treatments. Currently, information regarding saflufenacil degradation and persistence has not been available in scientific journals. However, information available from the Environmental

**Table 14.** First-order rate constant ( $k$ ), half-life ( $t_{1/2}$ ), 95% confidence limits of saflufenacil and adjusted coefficient of determination ( $R^2$ ) under saturation and field capacity soil conditions.<sup>a</sup>

Soil moisture	Soil series	$k$ ( $ \beta_{11} $ )	$t_{1/2}$ (days) <sup>b</sup>	95% confidence limits (days) <sup>b</sup>	$R^2$
Saturation	Nada	0.0120	58.8	51.9 – 68.4	0.86
	Morey	0.0114	61.8	54.3 – 71.7	0.87
	Crowley	0.0193	36.9	32.3 – 43.0	0.85
	Gilbert	0.0088	79.7	68.3 – 94.6	0.83
Field capacity	Nada	0.0251	28.6	22.1 – 41.0	0.58
	Morey	0.0110	64.0	53.5 – 80.7	0.74
	Crowley	0.0495	15.0	13.4 – 17.0	0.89
	Gilbert	0.0314	23.1	19.4 – 28.5	0.76

<sup>a</sup>Saflufenacil was applied at 2000 g ha<sup>-1</sup> (2.67 µg l<sup>-1</sup>). <sup>b</sup>A 1-day lag phase was added in the estimated half-life and 95% confidence limits.

Protection Agency (EPA) website reported that saflufenacil should not persist in aerobic soils with a half-life ranging from 7 to 35 days (EPA, 2009). Results obtained in this study for the field capacity treatments corroborated this statement as saflufenacil half-life ranged from 15 to 64 days. Morey soil had the longer half-life (64 days), but all the other samples had half-lives lower than 30 days.

A saflufenacil report available at EPA also indicated that herbicide degradation is slower in acidic to neutral water bodies (EPA, 2009) as half-life ranged from 28 to 70

days. Microbial activity in water bodies would be distinct than aerobic soils, but perhaps more similar to a soil flooding condition due the limitation in oxygen availability. Chemical degradation in water bodies seemed to be pH dependent (EPA, 2009). In the soil, flooding irrigation resulted in gradual stabilization of pH around the neutral range (Savant and Kibe, 1971). Therefore, differences in soil pH among soils would be minimized in the saturation treatments. Degradation patterns of pesticides under simulated rice field conditions were available in the literature, but no alternative moisture treatment was included for comparison (Doran et al., 2009; Jabusch and Tjeerdema, 2006). In studies considering contrasting moisture conditions (aerobic and anaerobic) half-life results were pesticide dependent. Atrazine and etofenprox degradation followed similar trend of saflufenacil, as biotransformation was slower under anaerobic conditions (DeLaune et al., 1997; Vasquez et al., 2011). For etofenprox, differences between moisture conditions diminished with increasing incubation temperature (Vasquez et al., 2011). However, studies investigating degradation of parathion and clomazone demonstrated that these pesticides dissipated more rapidly under anaerobic conditions (Sethunat and Yoshida, 1973; Tomco et al., 2010).

Microbial degradation of saflufenacil appeared to be the primary degradation mechanism under the conditions of this study. Both aerobic and anaerobic microbial populations encountered in the soil series were able to dissipate saflufenacil relatively rapidly over time. Differences in saflufenacil degradation were observed among soil samples. Crowley series had the shorter half-life among soils in both moisture treatments (Table 14). Nada, Morey and Crowley series under saturation conditions had the longer

half-life that was similar to Morey series when moisture was kept at field capacity. Saflufenacil is currently recommended for pre-plant burndown and pre-emergence in row crops. Under these conditions, herbicide would be applied primary in aerobic conditions that would favor dissipation according to results from this study. In rice, this herbicide is currently recommended only for pre-plant burndown applications. A supplemental label indicated that saflufenacil must be applied at least 15 days before planting and 45 days prior to establishment of permanent flood (CDMS, 2011). Therefore, saflufenacil application would be mainly performed with soils under aerobic conditions. In dry-seeded rice production system, flooding is established when the crop reaches the 4 to 5-leaf stage (Way, 2010). As a result, alternative herbicide usage timings in rice could be considered when managing saflufenacil application before flooding if faster degradation is required to minimize environmental risks. Furthermore, it is important to consider that under field conditions, moisture content would not be constant after applications of herbicides as in the controlled experimental environment. Drying and wetting cycles that frequently occur under field conditions have demonstrated to impact microbial activity (Chowdhury et al., 2011). Hence, this fluctuation in microbial metabolism may translate in changes in pesticide dissipation.

## **CONCLUSIONS**

Results from this study indicated that carbon mineralization was affected by field capacity and saturated (flooded) moisture conditions. Higher carbon mineralization was observed at field capacity indicating predominance of aerobic activity. Conversely,

flooded treatments resulted in lower CO<sub>2</sub> evolution indicating a shift to anaerobic microbial metabolism. Saflufenacil persistence in the environment was 2 to 3 times longer under flooded conditions for most of the soil series. Despite that, half-life no longer than 80 days was observed for the combination of soils and moisture treatments. An effective method to extract saflufenacil from soils samples was developed to perform the experiments using accelerated solvent extraction.

## CHAPTER VI

### DEVELOPMENT OF AN ADSORPTION WINDOW FOR PESTICIDES: A POTENTIAL ALTERNATIVE TO COMPARING SOIL ADSORPTION VALUES

#### INTRODUCTION

Interaction of pesticides with soil matrices has been studied since the 1950s as demonstrated in a review published in 1964 (Bailey and White, 1964). Pesticide usage in agricultural production increased after the Second World War (Robinson and Sutherland, 2002) creating the need to understand pesticide behavior in soil systems. Bioavailability and leachability were frequently employed to indirectly study adsorption of pesticides by soil colloids (Bailey and White, 1964). In 1965, Talbert and Fletchall conducted influential work determining the distribution coefficient ( $K_d$ ) of several *s*-triazine herbicides in multiple soils (Talbert and Fletchall, 1965).  $K_d$  values, which are the ratio of the pesticide quantity adsorbed in the substrate to the concentration remaining in solution, were determined using  $^{14}\text{C}$ -label herbicides. Ultimately, this technique became the standard for studying pesticide adsorption. As a result, the article achieved the citation classic status in 1986 as it had been cited in over 110 publications (Talbert, 1986).

In the same publication, the Freundlich equation was used to determine the distribution coefficient when a series of pesticide concentrations were analyzed for atrazine and simazine. Adsorption values obtained using this mathematical approach are referred as  $K_f$ . Some studies have demonstrated that adsorption is not affected over a



limited range of pesticide concentrations (Strebe and Talbert, 2001; Talbert and Fletchall, 1965). This would indicate that adsorption coefficients estimated using a single concentration ( $K_d$ ) and/or the Freundlich isotherm parameter ( $K_f$ ) result in similar adsorption values. However,  $K_d$  gradually decreases with a wide increment in pesticide concentration, resulting in non-linear models (Wauchope et al., 2002). Despite this fact, non-linear models had been used to generate adsorption isotherms (Carbo et al., 2007; Roy et al., 2000; Seybold and Mersie, 1996; Yazgan et al., 2005). In this case,  $K_d$  (single or averaged) and  $K_f$  values would vary considerably (Roy et al., 2000; Yazgan et al., 2005).

Furthermore,  $K_d$  adjustments using the organic carbon fraction result in a third estimate,  $K_{oc}$ , the soil organic carbon sorption coefficient (Baker et al., 1997; Brown and Flagg, 1981; Karickhoff et al., 1979).  $K_{oc}$  is calculated by dividing a measured  $K_d$  by the soil organic carbon fraction. Theoretically, once  $K_{oc}$  is determined for a compound in one soil,  $K_d$  for that molecule could be estimated in any other sample with knowledge of the organic carbon fraction. However, literature reviews have emphasized that  $K_{oc}$  estimation can be misleading as organic fraction determination varies between methods (Weber et al., 2000), interaction of polar compounds is preferred with the inorganic soil constituents (Wauchope et al., 2002; Weber et al., 2000) and compounds with ionizing properties are affected by soil pH (Wauchope et al., 2002; Weber, 1993; Weber et al., 2000).

Besides the issues concerning estimation and calculation of adsorption values, the guidelines describing the experimental procedures are not entirely standardized

(OECD, 2000), making it difficult to compare adsorption data published in the literature (Kah and Brown, 2007; Yazgan et al., 2005). For instance, batch equilibrium studies can be conducted with soil to solution ratios varying from 1:1 to 1:100 and guidelines are given to select a ratio which results in 30 to 50% adsorption (OECD, 2000). This implies that different ratios should be used to conduct a study with a range of soils and pesticides, therefore limiting the comparison of adsorption results obtained within the study (Kah and Brown, 2007). Besides, experiments had demonstrated that soil to solution ratio would affect adsorption values (Delle Site, 2001; Farmer and Aochi, 1974; Koskinen and Cheng, 1983; Roy et al., 2000). But, values contradicted conventional wisdom depending on herbicides, soil samples and method of determination (Farmer and Aochi, 1974; Kah and Brown, 2007; Koskinen and Cheng, 1983; Roy et al., 2000; Walker and Jurado-Exposito, 1998; Yazgan et al., 2005). As experimental variables such as soil to solution ratio affect the magnitude of the adsorption parameters ( $K_d$ ,  $K_f$ , and  $K_{oc}$ ), comparison of adsorption values among studies is not feasible (Kah and Brown, 2007; Yazgan et al., 2005).

Additionally, among the experimental procedures defined by the latest OECD guidelines, a 0.01 M calcium chloride ( $\text{CaCl}_2$ ) aqueous solution needs to be utilized to dissolve compounds for a batch equilibrium study (OECD, 2000). Conventionally, adsorption equilibration experiments had been conducted with  $\text{CaCl}_2$  aqueous solution since Talbert and Fletchall's original methodology (Talbert and Fletchall, 1965). Some of the reasons listed in the literature for using  $\text{CaCl}_2$ , as a background electrolyte, are to reduce soil mineral balance disruption (OECD, 2000; Wauchope et al., 2002) and

improve the centrifugation procedure (OECD, 2000). Perhaps, the primary reason for using  $\text{CaCl}_2$  is to help with flocculation of soil colloids (Vaezi et al., 2011), which results in less quenching and better efficiency of radioactivity counting. However, this process introduces ions that are not originally present in the sample, therefore artificially changing the chemical nature of the solid-liquid phase. The greater the aqueous volume in the slurry, the greater the amount of ions in the sample. More importantly,  $\text{CaCl}_2$  affects soil pH when compared with pure water (Ahern et al., 1995), potentially impacting the adsorption of pH dependent compounds such as weakly acid and basic herbicides (Wauchope et al., 2002; Weber et al., 2000). Effects of increasing ionic strength with  $\text{CaCl}_2$  has been reported since the 1970's resulting in reduction of pH and greater adsorption of weak acid herbicides such as picloram (Farmer and Aochi, 1974), 2,4-D (Moreale and Vanbladel, 1980) and 2,4,5-T (Koskinen and Cheng, 1983). Despite these implications, guidelines for adsorption/desorption studies suggest the use of  $\text{CaCl}_2$  solutions for batch equilibrium protocols (OECD, 2000) which have been followed in recent publications (Alister et al., 2011; Baglieri et al., 2011; Bermudez-Couso et al., 2011).

As a result, more than forty years after of Talbert and Fletchall's publication (Talbert and Fletchall, 1965) followed by extensive reviews addressing the limitations and reliability of sorption parameters (Wauchope et al., 2002; Weber et al., 2000) and tentative standardization of published values (Weber et al., 2000), the accurate comparison of adsorption results published by the scientific community remains unattainable as adsorption values are potentially affected by the methodology used.

Adsorption values must be calculated prior to pesticide registration (EPA, 2007) and are extensively used to understand environmental processes such as leaching and surface runoff (Briggs, 1990; de Wilde et al., 2008; Ma et al., 1996; Van der Linden et al., 2009) and biological activity such as biodegradation and plant availability (Kah and Brown, 2007; Schnurer et al., 2006). Therefore, alternatives that allow for accurate estimation of adsorption values for different chemical classes while creating options for comparison between and among studies could improve their use and interpretation in regulation policies and environmental fate models.

In this paper, the authors tested methodology to study  $K_d$  values of specific molecules simultaneously with pesticides of relatively weak and strong adsorptivity in soil. Theoretically, by having a minimum ( $K_{d(\min)}$ ) and a maximum ( $K_{d(\max)}$ ) adsorption value, this approach generates an adsorption window ( $K_{d(\max)} - K_{d(\min)}$ ), which may expand and contract depending on the relative adsorptive interactions between the pesticide and soil (Figure 19). Also, the use of multiple compounds allows for relative comparisons across experimental conditions. For instance, specific  $K_d$  values may be altered by changing soil to solution ratios (Farmer and Aochi, 1974; Koskinen and Cheng, 1983) or method of determination (Kah and Brown, 2007; Yazgan et al., 2005). However if the relative magnitude of adsorption can be measured within an adsorption window, results could be normalized and compared in a more appropriate and useful manner. Besides the standard batch equilibrium method (Wauchope et al., 2002), the concept could be tested using accelerated solvent extraction (ASE) as a potential rapid and automated pesticide sorption determination.

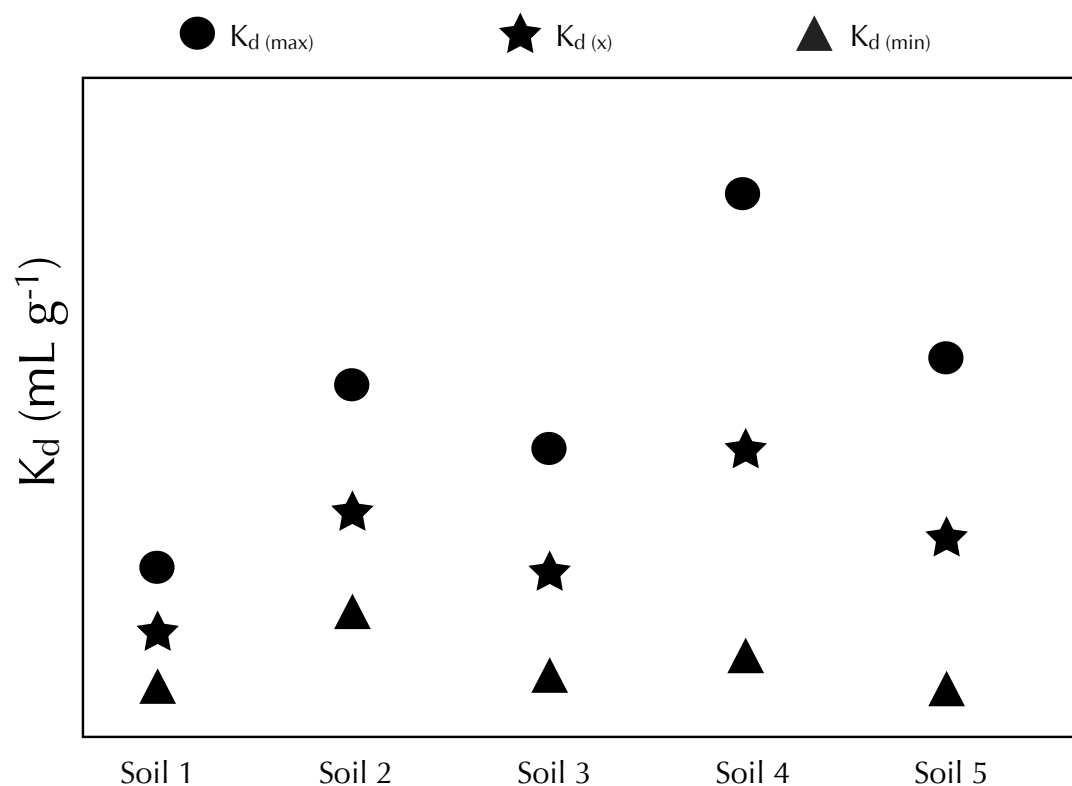

**Figure 19.** Conceptual results for studying adsorption a specific molecule ( $K_{d(x)}$ ) simultaneously with pesticides of relatively weak ( $K_{d(min)}$ ) and strong ( $K_{d(max)}$ ) adsorptivity in the soil. Approach generates potential for calculating an adsorption window ( $K_{d(max)} - K_{d(min)}$ ) which may expand and contract depending on soil sorption components. Also, the use of multiple compounds allows comparisons across different soil to solution ratios by accounting for the relative variation in pesticide adsorption.

The proposed idea can be developed with the use of ultra performance liquid chromatography (UPLC) coupled with mass spectrometry as an alternative to liquid scintillation counting. Quantification of parent molecules instead of the radioactivity from a label atom accounts for potential degradation during the equilibration period. Also, mass spectrometry detection provides an opportunity for quantification of multiple

compounds simultaneously as well as for testing effects of  $\text{CaCl}_2$  while avoiding quenching issues. Therefore, the objectives of this research were to investigate 1) the use of reference compounds (minimum and maximum  $K_d$  values) during the determination of pesticide adsorption with different soil to solution ratios, 2) the potential for using ASE as alternative for the standard sorption techniques, 3) the impact of  $\text{CaCl}_2$  on adsorption values measured using mass spectrometry, and 4) the potential for comparing adsorption of multiple compounds across methodologies.

## **MATERIALS AND METHODS**

### **Soils**

Ten soils were collected in a variety of environments and regions of the United States in an attempt to represent a wide range of soil characteristics. Samples were air-dried and then passed through a 2-mm sieve to remove non-decomposed plant residues. Subsequently, a representative sub-sample was submitted for analysis to the Texas AgriLife Research and Extension Soil Characterization Laboratory located in College Station, TX. Particle size distribution, total organic carbon, pH and cation exchange capacity results for each soil are presented in Table 15. Sand content, clay content, organic carbon and pH ranged from 6.4 to 91.0%, 4.9 to 49.2%, 0.47 to 10.46% and 4.5 to 8.2, respectively. Soil samples were stored at room temperature ( $25.5 \text{ C} \pm 1$ ) during the conduction of the studies.

**Table 15.** Physical-chemical characteristics of soil samples selected to conduct the studies.<sup>a</sup>

State	Soil series	Texture <sup>b</sup>	Sand	Silt	Clay	Organic carbon	pH	CEC
			-----%-----				Meq/100g	
TX	Nada	FSL	56.8	33.6	9.6	0.79	6.5	6.9
TX	Morey	L	29.4	46.5	24.1	1.21	7.8	26.3
LA	Crowley	SiL	8.3	77.3	14.4	1.18	5.7	12.2
LA	Gilbert	SiC	6.4	48.6	45	3.52	5.3	44.2
TX	Houston Black	SiC	9.6	41.2	49.2	1.65	7.8	49.6
OK	Lincoln	VFSL	59.5	29.7	10.8	0.50	7.3	8.1
NC	Arapahoe	FSL	64.7	25.2	10.1	10.46	4.9	45.2
NC	Candor I	LCoS	84.1	6.6	9.3	1.94	4.5	7.5
NC	Candor III	CoS	91	4.1	4.9	0.47	4.5	2.6
CO	Olney	FSL	71.1	11.6	17.3	0.49	8.2	12.2

<sup>a</sup>Samples were analyzed by Soil Characterization Laboratory located at Texas AgriLife Research and Extension, College Station, TX. <sup>b</sup>FSL, fine sandy loam; L, loam; SiL, silt loam; SiC, silty clay; VFSL, very fine sandy loam; LCoS, Loamy coarse sand and CoS, coarse sand.

**Table 16.** Chemical structures, recommended field rate, estimated sample rate and solubility in water of pesticides selected to conduct the studies.

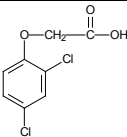
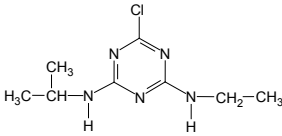
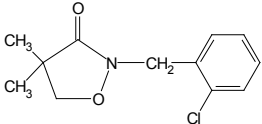
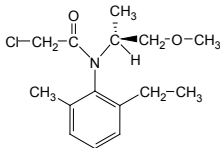
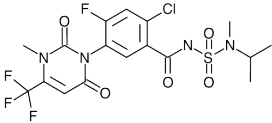
Herbicide name	Chemical structure	Application rate (g ha <sup>-1</sup> ) <sup>a</sup>	Sample application rate (µg g soil <sup>-1</sup> ) <sup>b</sup>	Solubility in water (µg mL <sup>-1</sup> ) <sup>c</sup>
2,4-D		560 (280-2240)	0.75	900
Atrazine		2200 (450-4500)	2.94	33
Clomazone		1400 (450-1400)	1.87	1100
<i>S</i> -metolachlor		2142 (1070-2677)	2.87	488
Saflufenacil		200 (25-150)	0.27	2100 at pH 7.0; 25 at pH 5.0; 14 at pH 4.0

<sup>a</sup>Application rate based on Senseman (2007), except for *S*-metolachlor and saflufenacil that was based on Dual II Magnum<sup>®</sup> and Sharpen<sup>®</sup> herbicide labels, respectively (rate selected to conduct the studies followed by rate range in parenthesis).

<sup>b</sup>Estimated using the selected application rate and a furrow slice of 5 cm (~2250 t of soil ha<sup>-1</sup> in a 15-cm furrow). <sup>c</sup>Extracted from Senseman (2007) except for saflufenacil that was extracted from Hixson (2008) and EPA (EPA, 2009).



### **Pesticides and other chemicals**

Five herbicides (2,4-D, atrazine, clomazone, *S*-metolachlor and saflufenacil) were selected to perform the adsorption studies. The compounds represented weak acid, weak base and non-polar chemistry to assess the impact of soil composition on adsorption of varying chemical characteristics. Estimated field application rates of the herbicides are listed in Table 16. Herbicide rate range was based on Senseman (2007), except for *S*-metolachlor and saflufenacil where the rate spectrum was based on Dual II Magnum<sup>®</sup> and Sharpen<sup>®</sup> registration labels. For 2,4-D, atrazine, clomazone, and *S*-metolachlor, herbicide rates applied primarily in row crops were selected to conduct the adsorption studies. The rate for saflufenacil herbicide was slightly higher than the maximum recommended amount to be applied in a cropping season to facilitate quantification.

The amount of each herbicide added to samples ( $\mu\text{g g soil}^{-1}$ ) was estimated using the assumption that a 15-cm furrow slice in a hectare would have approximately 2250 t of soil. Secondly, it was assumed that herbicides would be mainly concentrated in a 5-cm layer (750 t of soil). Therefore, a rate of  $560 \text{ g ha}^{-1}$  of 2,4-D for example would correspond to  $0.75 \mu\text{g of 2,4-D g soil}^{-1}$ . The same estimation procedure was used for all herbicides to generate the sample application rate that was used in all the performed studies. Herbicide analytical standards were acquired from Chem Service (West Chester, PA) except for saflufenacil that was provided by BASF Corporation (Research Triangle Park, NC). Purity of analytical standards was greater than 98.1%.

Stock solutions were prepared for each herbicide in methanol (UPLC grade) targeting concentrations from 200 to 300  $\mu\text{g mL}^{-1}$ . These concentrations allowed for preparation of aqueous solutions used in the batch equilibrium studies containing all the herbicides with less than 1% of methanol. Stock solutions were kept under refrigeration ( $\sim 3\text{ C}$ ) for storage.  $\text{CaCl}_2$ , formic acid, ultrapure water and acetonitrile (UPLC grade) were used during sample preparation and analysis.

### **Sample analysis**

Methodology was developed allowing the quantification and estimation of adsorption coefficients for all five herbicides in a single sample. The analyses were performed using a Waters ACQUITY<sup>®</sup> TQD integrating an UPLC with tandem quadrupole mass spectrometry detection (MS/MS). Tuning solutions for individual herbicides with concentration ranging from 1 to 5  $\mu\text{g mL}^{-1}$  were prepared from stock solutions. These solutions were used to optimize the detection and quantification of the herbicides by characterizing the ionization mode, the precursor and product masses, the cone voltage, and collision energy (Table 17). The autotune wizard of the IntelliStart<sup>™</sup> software (Waters Corporation, Milford, MA) was used to acquire the above listed parameters allowing for optimization and reliable detection of each herbicide during the analytical run. The ionization source temperature was 150 C and the desolvation temperature was 400 C. The desolvation gas ( $\text{N}_2$ ) and the cone gas flow rate were 800 and 50  $\text{L h}^{-1}$ , respectively.

**Table 17.** Herbicides molecular weight (MW), optimizing parameters for detection and quantification, and retention time during the UPLC/MS/MS analysis.

Parameters	Herbicides				
	2,4-D	Atrazine	Clomazone	<i>S</i> -metolachlor	Saflufenacil
MW (g mole <sup>-1</sup> )	221.04	215.69	239.70	283.80	500.86
Ionization mode <sup>a</sup>	ES-	ES+	ES+	ES+	ES+
Precursor ion (Da)	220.9	216.1	240.1	284.2	501.2
Product ion (Da)	162.8	174.0	124.9	252.0	197.9
Cone voltage (V)	20	30	30	30	45
Collision energy (V)	12	18	16	14	46
Retention time (min)	1.459	1.493	2.025	4.290	2.884

<sup>a</sup>ES, electrospray ionization.

Subsequently, a UPLC method was developed using the ACQUITY<sup>®</sup> UPLC HSS T3 (1.8  $\mu$ m, 2.1 mm x 75 mm) analytical column coupled with an ACQUITY<sup>®</sup> HSS T3 (1.8  $\mu$ m, 2.1 mm x 5 mm) VandGuard pre-column. An isocratic mobile-phase (50:50) was pumped from two solvent reservoirs (A, ultrapure water with 0.05% formic acid and B, acetonitrile). The sample run time was 5.5 minutes using a flow rate of 0.4 mL min<sup>-1</sup>. The sample injection volume was 5  $\mu$ L. Retention times of each herbicide are listed in Table 17. Calibration standards containing all herbicides were prepared in methanol at 1, 10, 50, 100, 250, 500 and 750 ng mL<sup>-1</sup>. These concentrations encompass the expected range of responses in the analyzed samples. The  $r^2$  for each calibration curve and for

each herbicide was above 0.998. Calibration standards were included in every analyzed sample set.

### **Batch equilibrium method**

Three soil to solution ratios (1:3, 1:5 and 1:10) were chosen to study adsorption of the 5 herbicides in the 10 selected soils using the batch equilibrium method. Samples of each soil were weighed (1 g) and were placed in a 50 mL round bottom centrifuge tube (Pyrex<sup>®</sup>, Lowell, MA). Herbicide stock solutions were removed from the refrigerator and set in the laboratory bench to reach equilibrium with room temperature before use. Subsequently, a solution containing all five herbicides was prepared using ultrapure water without CaCl<sub>2</sub>. Final concentration in aqueous solution was based on concentration of the individual herbicide stock solutions. The solution was prepared such that the herbicide rates in  $\mu\text{g g soil}^{-1}$  (Table 16) were added into the soil samples in the aqueous aliquot. Three, five and ten mL of aqueous solution were added in 1 g of soil to generate the three soil to solution ratios. Herbicide application rate in soil was identical for all three soil to solution ratios. Therefore, herbicide concentration in the aqueous solution was dependent on the soil to solution ratio treatments. For instance,  $0.75 \mu\text{g g soil}^{-1}$  was the targeting rate for 2,4-D. Therefore, a solution with 0.25, 0.15 and  $0.075 \mu\text{g mL}^{-1}$  of 2,4-D was prepared for the 1:3, 1:5 and 1:10 ratio, respectively. An identical calculation procedure was followed for all herbicides.

Additionally, herbicides were combined in an ultrapure water solution containing 0.01 M of CaCl<sub>2</sub>. CaCl<sub>2</sub> was only used to perform an additional comparison study for all

soils using the 1:5 soil to solution ratio. Concentration of the herbicides in water was significantly lower than solubility limits in all the prepared aqueous solutions. The amount of organic solvent (methanol) was maintained lower than 1% in the aqueous solution. A fresh aqueous solution was prepared every time a new set of samples was organized for an equilibration run. Herbicides in the aqueous solution were pipetted inside centrifuge tubes containing the soil samples. The volume added was dependent on soil to water ratio.

Subsequently, herbicides were equilibrated with soil samples for a period of 24 hours in a side-to-side shaker ( $125 \text{ cycles min}^{-1}$ ) at room temperature ( $24.5 \text{ C} \pm 0.5$ ). Equilibration time was based on work conducted previously with 2,4-D (Duwig et al., 2006) atrazine (Abate et al., 2004; Seybold and Mersie, 1996), clomazone (Li et al., 2004), *S*-metolachlor (Krutz et al., 2004; Seybold and Mersie, 1996) and saflufenacil (Hixson, 2008). After shaking for 24 hours, samples were centrifuged at  $2,500 \times g$  for 20 min. A uniform aliquot ( $\sim 1.5 \text{ mL}$ ) of the supernatant was removed from each sample tube using a glass pipette and placed inside a 3-mL syringe coupled with a disposable filter device (PVDF filter media, 13 mm,  $0.2 \mu\text{m}$  pore size, Whatman Inc., Piscataway, NJ). Aliquots were then filtrated to remove soil particles suspended in solution. From the filtrate, two- $600 \mu\text{L}$  aliquots were measured using a pipette and transferred into UPLC vials to run samples in duplicates.

In the final sample volume, a proportion of acetonitrile (25% of the total) was added to increase sample stability, reduce potential vial-herbicide interactions and facilitate herbicide solubility. A preliminary study was performed to evaluate the

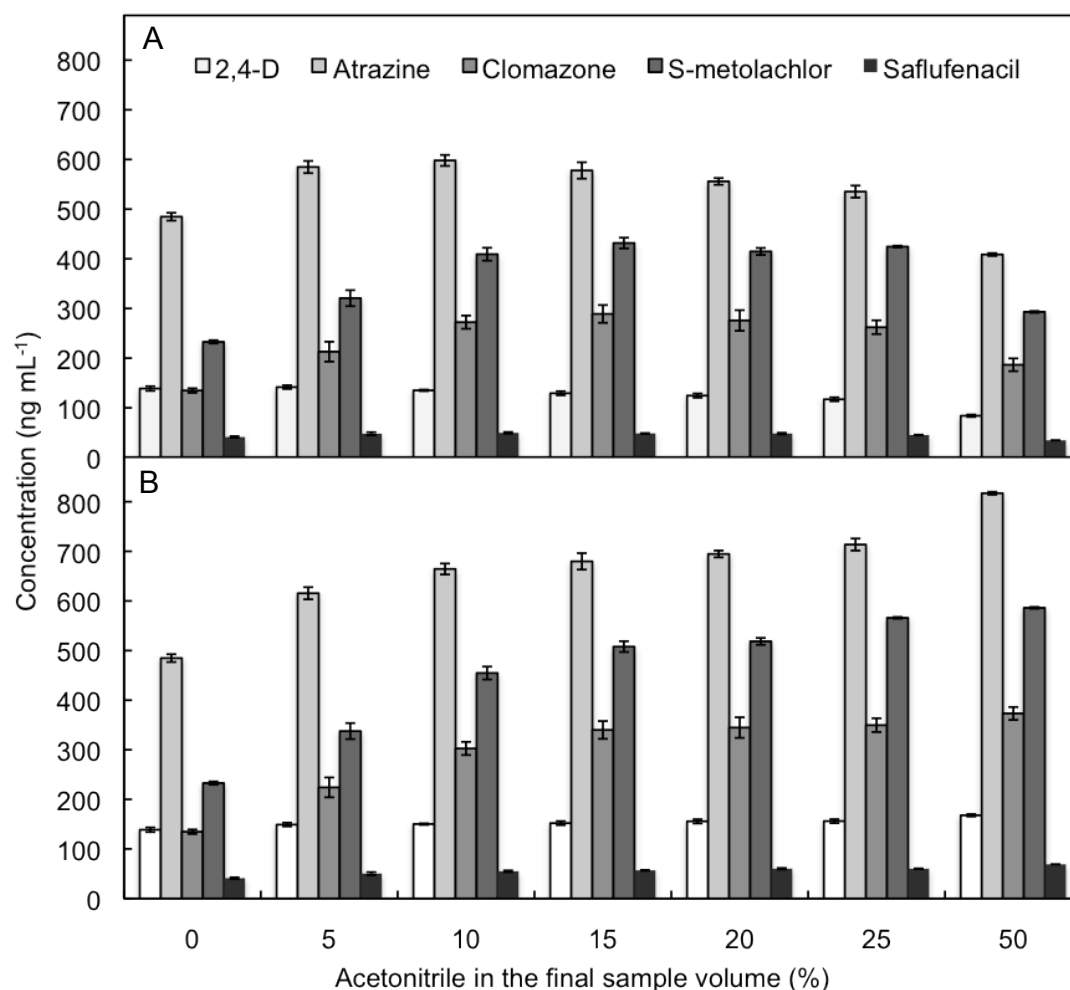

**Figure 20.** Herbicide concentrations (ng mL<sup>-1</sup>) obtained after interpolating with individual calibration curves (A) following dilution correction for adding six proportions of acetonitrile in the final sample volume (B). Bars represent 95% confidence intervals of 4 replications.

contribution of adding acetonitrile in the final sample volume. Results indicated that adding acetonitrile starting at 5% improved the intensity of response especially for atrazine, clomazone and *S*-metolachlor (Figure 20A). Increasing acetonitrile up to 25% in the final sample volume did not result in significant reduction in peak response by the impact of sample dilution. Conversely, sample dilution effects were observed when 50%

of the total sample volume was composed of acetonitrile. Also, correction to the original sample concentration considering the dilution factor of adding acetonitrile from 15 to 25% resulted in a stable response for all herbicides (Figure 20B). Therefore, 25% of acetonitrile (200  $\mu\text{L}$ ) was added in the final sample volume and swirled vigorously for 10 sec using a vortex mixer before performing the analytical analysis.

Preliminary quality assurance data included competitive interaction among herbicides for adsorption sites in the soils, adsorption in centrifuge tubes, and residual presence of each herbicide in the soil samples. For each fresh aqueous solution prepared, six aliquots with 600  $\mu\text{L}$  were removed and placed in UPLC vials. These samples were maintained for the entire equilibration period in the room where soil samples were agitated to expose them to the similar temperature environment ( $24.5\text{ C} \pm 0.5$ ). Also, two samples containing only the aqueous solution (without soil) were included in every analytical sample set to assess herbicide interaction with glassware and overall efficiency of the sample preparation procedure. Aqueous solution aliquots and quality control samples were used to quantify the amount of herbicide added in the soils (control samples). Therefore, these samples were fundamental for calculation of the single point adsorption coefficient  $K_d$  ( $\text{mL g}^{-1}$ ) (Cleveland, 1996), which was estimated as follows:

$$(2) \quad K_d = \frac{V(C_c - C_s)/m_s}{C_s}$$

where  $V$  (mL) is the volume of the aqueous solution added to create the different soil to solution ratios,  $C_c$  ( $\text{ng mL}^{-1}$ ) is the averaged concentration in the control samples,  $C_s$  ( $\text{ng mL}^{-1}$ ) is the concentration in the soil samples supernatant/extract, and  $m_s$  is the soil sample mass (1 g).

### **Adsorption using accelerated solvent extraction (ASE)**

A solution was prepared in 10 mL of methanol using individual herbicide stock solutions. Concentrations were estimated such that application of 250  $\mu\text{L}$  in 5 g of soil would correspond with the application rate of each herbicide (Table 16). Herbicide rates were identical to the batch equilibration experiment. Samples of each soil (5 g) were weighed in hexagonal weighing boats. Subsequently, herbicides dissolved in methanol were applied and thoroughly mixed in the soil. Weighing boats were placed inside a fume hood for 20 minutes to allow evaporation of solvent from soil samples. Boats were then removed from the hood and 0.5 g of Hydromatrix<sup>®</sup> (inert diatomaceous earth, Agilent Technologies Inc., Santa Clara, CA) was combined with each soil sample. Soil samples treated with herbicides and mixed with Hydromatrix<sup>®</sup> were added into 11-mL extraction cells. Empty spaces on the top of the cells were filled with washed sand (Ottawa sand, EMD Chemicals Inc., Gibbstown, NJ). To estimate the initial concentration of herbicides added in the soils (control samples), two collection vials with 18 mL of water were kept in the ASE collection vial tray during sample extraction after adding 250  $\mu\text{L}$  of the solution containing all herbicides. These samples followed identical post-extraction procedure as the soil samples.

Methodology was created to test the potential of using ASE for a more rapid and automated pesticide sorption determination. The ASE method (ASE 200, Dionex Corporation, Sunnyvale, CA) consisted of using water as solvent, one hour of equilibration time (static cycle), and 10.3 MPa of cell pressure. The extraction temperature of  $25.5\text{ C} \pm 1$  was obtained by keeping the instrument oven off. After



introducing water in the extraction cell, pressure and temperature were maintained at the desired specifications for 1 h to equilibrate. Approximately 10 mL of water was added in the extraction cell (11-mL) considering the previously described sample preparation procedures. As for comparison with the batch equilibration, a 1:2 soil to solution ratio was obtained with ASE. After the one-hour equilibration time, the extraction cell was flushed with fresh water equal to 60% of the cell volume. Solvent was purged from the cell by a stream of N<sub>2</sub> gas for 150 s and discharged into the collection vial. After sample extraction, the volume obtained in the collection vial was weighed and brought to 18 mL to standardize the variation in extraction volume among soil samples.

A uniform aliquot was removed from each sample and placed inside a 3-mL syringe coupled with a disposable filter device (Whatman, PVDF filter media, 13 mm, 0.2 µm pore size). Aliquots were then filtrated to remove soil particles suspended in solution. From the filtrate, two 600-µL were measured using a pipette and transferred into UPLC vials to run samples in duplicates. In the final sample volume, 25% of acetonitrile (200 µL) was added and swirled vigorously for 10 sec using a vortex mixer before performing the analytical analysis.  $K_d$  was estimated using the equation described in the previous sub-section employing  $V = 18$  mL and  $m_s = 5$  g.

### **Statistical analysis**

The studies were conducted as a randomized complete block design with factorial arrangement of soils, herbicides, and  $K_d$  equilibration methods. Treatments were repeated in time with five replications and samples were analyzed in duplicate.

Experiments with 1:5 soil to solution ratio (with and without CaCl<sub>2</sub>) were analyzed separately. All results were subjected to ANOVA using SAS (Statistical Analysis Systems, 9.2 Software, SAS Institute Inc., Cary, NC). Prior to analysis error assumptions (independence, homogeneity, and normality) were verified using Bartlett's, Kolmogorov-Smirnov's and Shapiro-Wilk's Test. *F*-values were obtained for individual sources of variation (soil, herbicide, and K<sub>d</sub> method) and for multiple combinations of the factors. Means for significant effects were separated using 95% confidence intervals. Linear regression analyses were conducted for the estimated adsorption window results.

## **RESULTS AND DISCUSSION**

### **Effect of CaCl<sub>2</sub> on K<sub>d</sub> coefficients**

A three-way interaction was indicated by ANOVA for the K<sub>d</sub> values obtained using herbicides dissolved in solutions with or without CaCl<sub>2</sub> at a 1:5 soil to solution ratio. Subsequently, results were analyzed by herbicides to verify the impact of CaCl<sub>2</sub> (0.01 M) and soil samples. Significant differences in 2,4-D adsorption were observed by overlapping 95% confidence intervals in 6 of the 10 soil samples selected in this study. K<sub>d</sub> values estimated with addition of CaCl<sub>2</sub> were 1.8 to 4.8-fold greater than values obtained using only water (Figure 21A). Greater adsorption of weak acid compounds including 2,4-D in the aqueous solution with CaCl<sub>2</sub> has been described previously in the literature (Farmer and Aochi, 1974; Koskinen and Cheng, 1983; Moreale and Vanbladel, 1980). The magnitude of change was particularly evident in the soil samples with higher organic carbon content (Candor I, Gilbert, and Arapahoe). For instance, in the Candor I

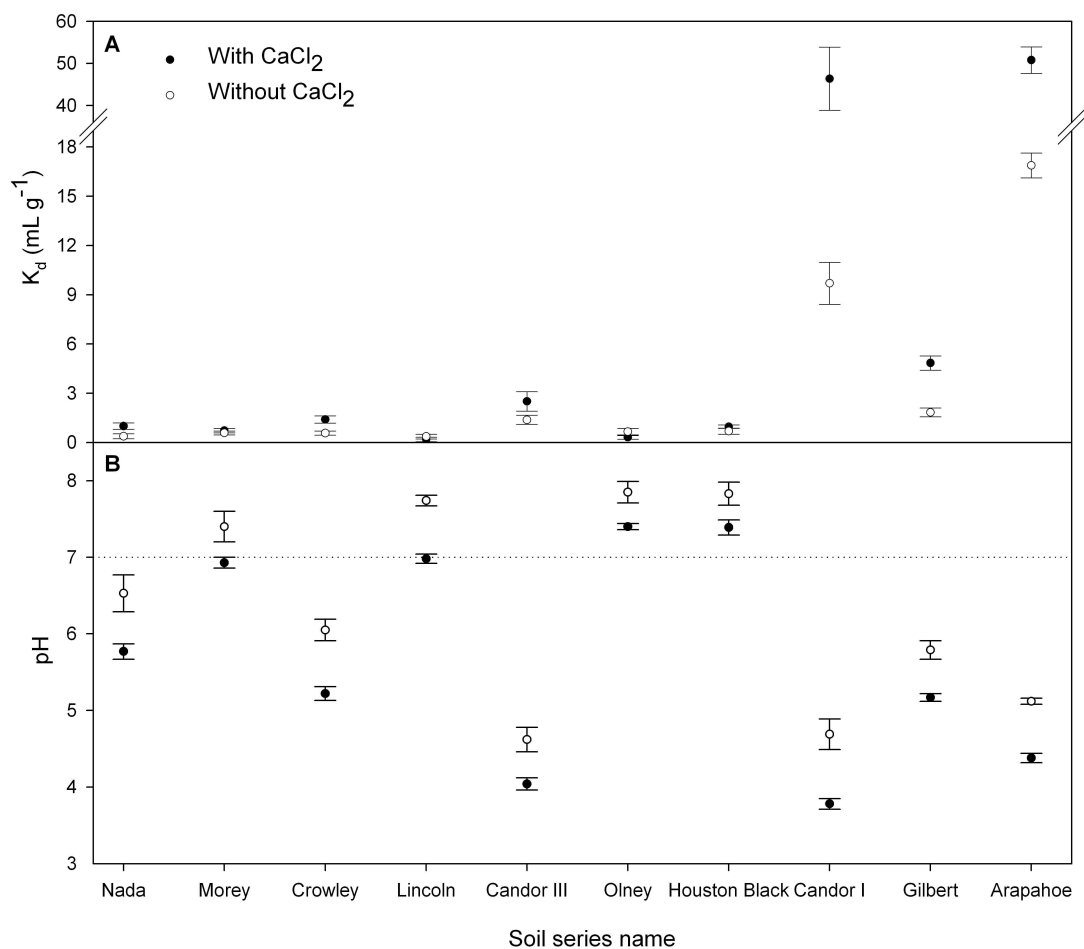

**Figure 21.** Adsorption coefficient for 2,4-D (A) and pH of soil samples (B) after equilibration for 24 hours in solution with (shaded dots) and without (opened dots) calcium chloride (0.01 M). Experiments were conducted using a 1:5 soil to solution ratio. Bars represent 95% confidence intervals of 5 replications. In the Figure 21A, vertical axis has a 3 and 10-unit scale interval before and after the break, respectively. Dotted line represents pH 7.0 in the Figure 21B.

soil series,  $K_d$  values increased from 9.7 to 46.4 mL g<sup>-1</sup> when 0.01 M of CaCl<sub>2</sub> was added. Some of the adsorption differences reported for 2,4-D could be explained by the reduction in sample pH with CaCl<sub>2</sub>. All soils samples displayed lower pH when adding

CaCl<sub>2</sub> compared with pure water (Figure 21B) following similar behavior described by Ahern and others (1995) when comparing pH measurement methods in soil. According to the Henderson–Hasselbalch equation ( $\text{pH} = \text{pK}_a + \log ([\text{A}^-]/[\text{HA}])$ ), the proportion of molecular species (HA) increases for a given pK<sub>a</sub> as pH decreases in solution. Therefore, a greater proportion of 2,4-D in the associated form due to a more acidic environment led to strong interaction with soil constituents, especially the organic fraction, thereby increasing K<sub>d</sub> values. Similar observations were reported for picloram as early as 1974 (Farmer and Aochi, 1974). However, use of CaCl<sub>2</sub> continues to be indicated on the adsorption/desorption guidelines (OECD, 2000) and it is regularly used in the latest published studies (Alister et al., 2011; Baglieri et al., 2011; Bermudez-Couso et al., 2011). Clearly the ionic strength modification with use of salts in the batch equilibration method potentially alters the adsorption results of pH-dependent molecules. Accordingly to Wauchope and others (2002), one-third of the modern pesticides fall into this category. Consequently, addition of CaCl<sub>2</sub> in adsorption/desorption determinations impact adsorption results of a large number of molecules. Besides the reduction in solution pH, use of CaCl<sub>2</sub> can induce changes in chemical solubility, cation composition at the soil particle surface, and surface character of the organic fraction (Farmer and Aochi, 1974) that may further explain the adsorption differences with pure water.

For the alkaline soil samples where pH remained near 7.0 even after adding CaCl<sub>2</sub> (Morey, Lincoln, Olney and Houston Black) adsorption values of 2,4-D were similar with and without CaCl<sub>2</sub>. In these four soil samples, the ionized form of 2,4-D would be the predominant species, resulting in low adsorption values despite the fact that pH was

reduced with  $\text{CaCl}_2$ . The effects of pH on adsorption of 2,4-D can be compared between Candor III (pH 4.5) and Olney (pH 8.2). These soil series have more than 70% sand and a similar amount of organic carbon ( $\sim 0.5\%$ ) with significant differences in pH (acid to alkaline). Adsorption of 2,4-D was 2-fold greater in Candor III series ( $1.4 \text{ mL g}^{-1}$ ) compared with Olney series ( $0.7 \text{ mL g}^{-1}$ ) when using pure water. However, an 8-fold difference was observed when  $\text{CaCl}_2$  was used for adsorption determination. According to these findings, comparison of adsorption in soils within a range of pH could be misleading for 2,4-D when determination is conducted using  $\text{CaCl}_2$  since ionic strength seems to impact primarily soils with pH lower than 7.0. Similarly to 2,4-D, addition of  $\text{CaCl}_2$  resulted in higher  $K_d$  values for saflufenacil, however differences were observed in only two soil samples.  $K_d$  values of  $4.8 (\pm 0.4)$  and  $3.5 (\pm 0.4) \text{ mL g}^{-1}$  were obtained with  $\text{CaCl}_2$  in comparison with  $3.0 (\pm 0.4)$  and  $1.9 (\pm 0.3) \text{ mL g}^{-1}$  in absence of  $\text{CaCl}_2$  for Arapahoe and Candor I soils, respectively. Saflufenacil is an herbicide with weak acid character based on the ionization constant in aqueous solution ( $\text{pK}_a$  of 4.4) (Grossmann et al., 2011). Therefore, pH reduction with  $\text{CaCl}_2$  would increase the proportion of associated molecules increasing non-polar interactions especially in the soil samples with high organic carbon content such as Arapahoe and Candor I. Effects of pH reducing herbicide solubility could be also affecting adsorption in low pH soils as saflufenacil solubility decrease from  $2100 \mu\text{g mL}^{-1}$  at pH 7.0 to  $14 \mu\text{g mL}^{-1}$  at pH 4.0 (EPA, 2009).

Presence or absence of  $\text{CaCl}_2$  also altered results obtained from clomazone and *S*-metolachlor in some soils. The presence of  $\text{CaCl}_2$  reduced  $K_d$  values of clomazone from  $7.4 (\pm 0.5)$  to  $5.1 (\pm 0.4) \text{ mL g}^{-1}$  in the Gilbert soil. Similarly, lower  $K_d$  values were

obtained for *S*-metolachlor in three soils. Addition of  $\text{CaCl}_2$  resulted in adsorption coefficients of  $7.5 (\pm 0.4)$ ,  $2.7 (\pm 0.3)$ , and  $1.6 (\pm 0.3)$   $\text{mL g}^{-1}$  compared with  $13.8 (\pm 0.8)$ ,  $4.3 (\pm 0.3)$ , and  $3.5 (\pm 0.4)$   $\text{mL g}^{-1}$  in samples equilibrated without  $\text{CaCl}_2$  for Gilbert, Crowley and Nada soils, respectively. Normally, these results would not be expected for clomazone and *S*-metolachlor that are non-ionic herbicides (Senseman, 2007; Wauchope et al., 2002) and reduction in pH by  $\text{CaCl}_2$  should not affect the adsorption values (Senseman, 2007). However, modification in the nature and surface of the organic matter fraction has been reported among the soil characteristics that can be altered by addition of salts such as  $\text{CaCl}_2$  (Farmer and Aochi, 1974). Perhaps, calcium could change the polarity and saturation of the organic fraction and therefore suppress the accessibility of the adsorption sites. Adsorption of *S*-metolachlor in the Nada soil series was the only situation with variation in  $K_d$  greater than 2-fold among the samples with significant differences in adsorption for clomazone, *S*-metolachlor and saflufenacil in solution with or without  $\text{CaCl}_2$ .

$K_d$  values for atrazine were not significantly affected by addition of  $\text{CaCl}_2$  in the aqueous solution in any of the analyzed soil samples (data not shown). Atrazine is a weakly basic herbicide with a  $\text{pK}_a$  of 1.7 (Senseman, 2007) in which adsorption generally increases as acidity increases (Weber, 1993). Despite that fact,  $\text{CaCl}_2$  reduction in pH in all samples did not reflect in significant changes in atrazine adsorption. The reasoning for using  $\text{CaCl}_2$  is not described in the Talbert and Fletchall's original article. However, pH of soils was determined in a 0.01 M  $\text{CaCl}_2$  solution (Talbert and Fletchall, 1965) and perhaps the authors were trying to simulate the soil testing procedure. Most

probably,  $\text{CaCl}_2$  was used to reduce quenching issues during radioactivity counting. However, results indicated unacceptable changes in  $K_d$  values, especially for weak acid herbicides such as 2,4-D. Therefore, use of aqueous solution without  $\text{CaCl}_2$  is proposed as part of a more accurate method of soil adsorption determination.

Mass spectrometry detection can generate an alternative to radiolabeled carbon molecules eliminating potential issues with quenching during quantification analysis. Therefore, the proposed methodology may facilitate the development of studies because analytical standards are cheaper and more easily obtainable compared with radioactive molecules. Besides, new generation of more sensitive instruments might allow for quantification of field-applied rates of several molecules simultaneously while standard adsorption techniques using radiolabeled materials are typically done one compound at a time.

### **Herbicides adsorption and equilibration methods**

A three-way interaction was observed for the sources of variation. This was expected considering the range of soil samples, herbicides and equilibration methods (soil to solution ratios using batch equilibrium and ASE). Results were then analyzed within each soil samples.  $K_d$  values ranged from approximately 0 up to  $80.6 \text{ mL g}^{-1}$  (Figure 22). Multiple patterns of response were observed for adsorption values as function of equilibration methods in the tested soils. This behavior agrees with results observed in previous studies where changes in  $K_d$  values were dependent on herbicides,

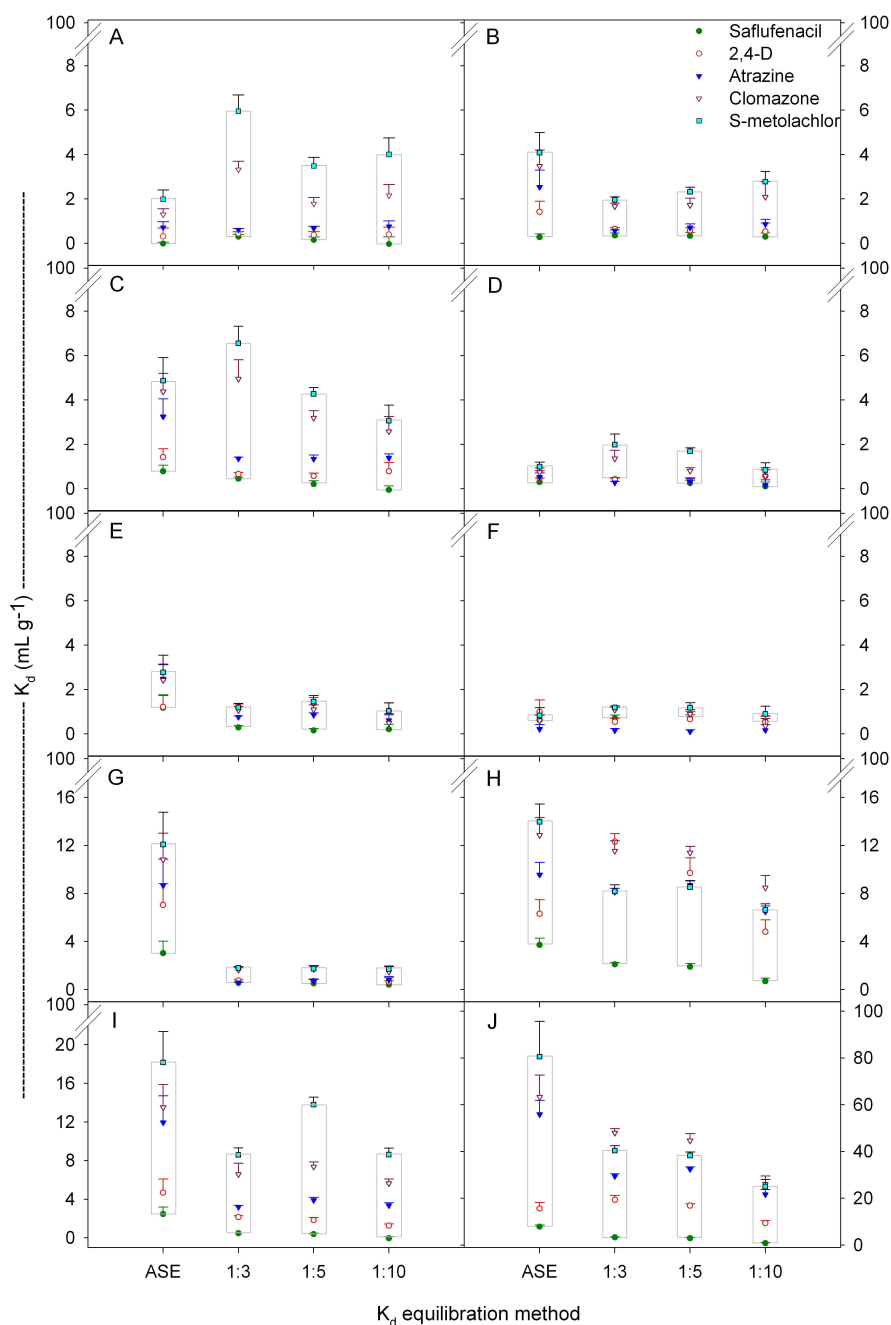

**Figure 22.** Adsorption coefficient ( $K_d$ ) of five herbicides for selected soil samples determined using three different soil to solution ratios and accelerated solvent extraction (ASE). A, Nada; B, Morey; C, Crowley, D, Lincoln, E, Candor III; F, Olney; G, Houston Black; H, Condor I; I, Gilbert; J, Arapahoe. Bars represent positive side of 95% confidence intervals. Vertical axes have a different scale interval before the break. Figure 22J does not have a scale break. Boxes represent the difference from the *S*-metolachlor ( $K_{d(S\text{-meto})}$ ) and saflufenacil ( $K_{d(\text{safl})}$ ) adsorption coefficients.



soil samples and method of determination (Farmer and Aochi, 1974; Kah and Brown, 2007; Koskinen and Cheng, 1983; Roy et al., 2000; Yazgan et al., 2005). In the Olney soil, all the equilibration procedures generated similar results within each herbicide tested with overall  $K_d$  values ranging from 0.1 to 1.2 mL g<sup>-1</sup> (Figure 22F). Similar trends were observed for most of the herbicides in the Lincoln soil (Figure 22D) and for all herbicides among the soil to solution ratios using the batch equilibrium in the Candor III and Houston Black series (Figure 22E and 4G, respectively). Olney, Lincoln and Candor III soil series have the lowest organic carbon content (approximately 0.5%) and low percentage of clay in the texture composition. Therefore, these soils are not strong sorbents as organic carbon and clay content are important in adsorbing organic chemicals among the soil constituents (Weber et al., 2004). In these samples, the methods of equilibration generated similar results, especially the three soil to solution ratios in the batch equilibrium technique. Consequently, these results indicated that for matrices with limited adsorptive capacity,  $K_d$  estimation could be obtained without discrepancy by using the 1:3, 1:5 or 1:10 soil to solution ratios. Moreover, in the Houston Black series the three soil to solution ratios provided similar results within each herbicide. Unexpectedly, this soil sample resulted in absorption values ranging from 0.4 to 1.8 mL g<sup>-1</sup> despite the relatively high percentage of organic carbon (1.65%). In general, *S*-metolachlor generated the highest  $K_d$  values for this soil. Average  $K_d$  values of 4.39 mL g<sup>-1</sup> for metolachlor were obtained in previous studies using the Houston Black series in samples with 2.5% of organic carbon (Krutz et al., 2004).

Adsorption among herbicides generally increased in the following order: saflufenacil < 2,4-D < atrazine < clomazone < *S*-metolachlor. Besides the soil samples previously described,  $K_d$  values for saflufenacil, 2,4-D and atrazine were similar among the batch equilibration ratios in the Nada, Morey and Crowley series. However, adsorption of clomazone and *S*-metolachlor were affected by the soil solution ratios in several samples, reinforcing that methodological differences are associated with the nature and strength of pesticide-soil interaction. For the two herbicides, a general tendency was observed of decreasing adsorption as water volume increased in the slurry (Figure 22A, C, D, H, and J). Differences were especially evident between the 1:3/1:5 samples compared with 1:10 soil to solution ratio.

Furthermore, similar trends were observed for all herbicides in the Condor I, Gilbert and Arapahoe series (Figure 22H, I, and J). In these samples, adsorption values were higher (see graph scale) partially due to the high content of organic carbon and low pH (which increases adsorption of pH dependent pesticides used in this study), resulting in more discernible contrasts among soil solution ratios. Therefore, the soil to solution ratio selected to conduct a batch equilibrium study would affect  $K_d$  values, especially in matrices with high adsorptive capacity and for compounds that enable higher attraction at the adsorbent surface. If the interaction of soil samples and herbicides resulted in  $K_d$  values  $\geq 2 \text{ mL g}^{-1}$  then increasing the solution to soil ratio with the bath equilibrium significantly altered the  $K_d$  values.

ASE is a technique that has been successfully used for extraction of organic molecules on a distinct array of matrices (Ding et al., 2011; Gentili et al., 2004; Hossain

et al., 2011; Lancaster et al., 2007). It has been used successfully as an extraction procedure, but there is no literature reporting its potential use as an alternative to estimate adsorption values. In at least six soil samples (Morey, Candor III, Houston Black, Candor I, Gilbert and Arapahoe)  $K_d$  values estimated with ASE were significant higher in all the tested herbicides than most of values obtained with the batch equilibrium. For clomazone and *S*-metolachlor,  $K_d$  values of similar magnitude were obtained when compared with the 1:3 soil to solution ratio in the Crowley series, however lower values were estimated with ASE for the same comparison on the Nada samples. As mentioned in the methodology, ASE procedure resulted in a soil to solution ratio of approximately 1:2 during the equilibration period. Therefore, results obtained with this technique follow similar trends of increasing adsorption with lower volumes of solution. Furthermore, an aging effect could be associated with the ASE equilibration as molecules may be forced into crevasses of the soil further increasing adsorption. Higher variability observed in the ASE results perhaps is due to the fact that lower volumes of aqueous solution were used and that soluble herbicides had to move through the soil column before reaching the collection cells.

### **Adsorption Window (AW)**

Determination of adsorption in multiple compounds allowed for calculation of an adsorption window (AW). Adsorption values obtained with *S*-metolachlor ( $K_{d(S\text{-meto})}$ ) and saflufenacil ( $K_{d(safl)}$ ) were used to estimate the AW because for the majority of the soils and equilibration methods these herbicides provided the maximum and minimum  $K_d$

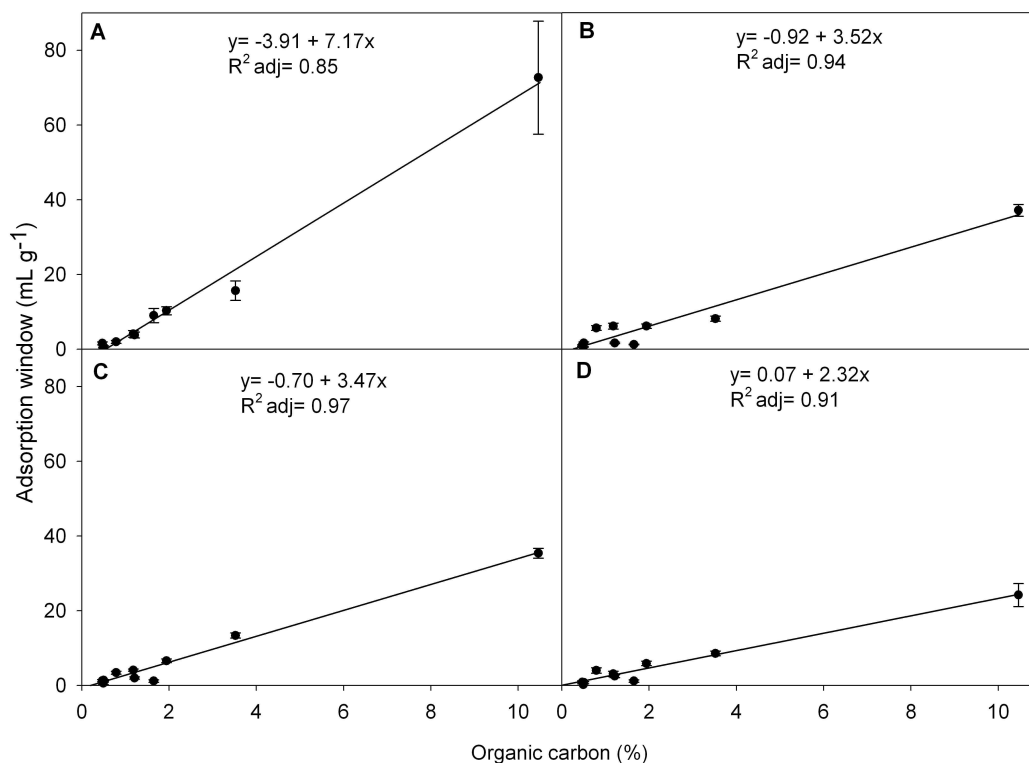

**Figure 23.** Adjusted linear regression for relative length of the adsorption window (AW, difference from the *S*-metolachlor ( $K_{d(S\text{-meto})}$ ) and saflufenacil ( $K_{d(safl)}$ ) adsorption values) as a function of organic carbon content in soil samples. A, ASE; B, 1:3; C, 1:5; D, 1:10. Bars represent 95% confidence intervals.

values. Therefore, AW was calculated by subtracting by the averaged adsorption value of *S*-metolachlor from the averaged adsorption value of saflufenacil in each individual sample ( $K_{d(S\text{-meto})} - K_{d(safl)}$ ). A gray box in every soil series and equilibration method combination visually illustrates the AW estimation (Figure 22).

The magnitude of adsorption window was mainly affected by the change in the  $K_{d(S\text{-meto})}$ . Linear regressions were estimated for the AW as a function of soil organic carbon for every equilibration method (Figure 23). Slope increased with reduction of

aqueous solution and all methods provided a highly significant response for AW as a function of organic carbon. This indicated that the AW could be used to compare soil matrices and might help scientists adjust and use modeling techniques more accurately. This methodology has potential for accounting the variation in adsorption response due to the amount of aqueous solution used in the equilibration step. Therefore, the novel approach for conducting adsorption studies while using reference compounds with the compound(s) of interest has potential to better compare pesticide adsorption as well as to more effectively compare results obtained using different soil:solution ratios.

#### **Adsorption Relativity Coefficient (ARC)**

Considering that the various equilibration methods provided contrasting results depending on the soil sample and herbicide,  $K_d$  results of 2,4-D, atrazine and clomazone were calculated according to their relative position along the AW scale in an attempt to normalize results. Adsorption relativity coefficient (ARC) was not estimated for Olney, Lincoln and Condor soil series as these samples had an  $AW \leq 2 \text{ mL g}^{-1}$  among all equilibration methods.  $K_d$  values in these soils were generally not affected by equilibration methods due to limited adsorption capability. Therefore,  $K_d$  adjustments among equilibration methods were not necessary for these soils. ARC was not calculated for *S*-metolachlor and saflufenacil as these herbicides were used as reference compounds during the calculation of the AW. ARC was calculated using the  $K_d$  value of the compound of interest ( $K_{d(x)}$ ) subtracted by the  $K_{d(\text{saf})}$ . The obtained result was divided by the AW ( $K_{d(S\text{-meto})} - K_{d(\text{saf})}$ ). The following equation describes the ARC calculation.

$$(3) \text{ ARC} = \frac{K_{d(x)} - K_{d(\text{saf})}}{K_{d(S\text{-meto})} - K_{d(\text{saf})}}, \text{ that can also be rewritten as } \text{ARC} = \frac{K_{d(x)} - K_{d(\text{saf})}}{AW}$$

The ARC index can be a negative value ( $K_{d(x)} < K_{d(\text{saf})}$ ), a value ranging from 0 to 1 ( $K_{d(x)}$  within the AW range) or a value  $> 1$  ( $K_{d(x)} > K_{d(S\text{-meto})}$ ). Therefore, a negative ARC or an ARC close to 0 indicates that the particular compound is less adsorptive or has similar adsorption behavior than saflufenacil. On the other extreme of the scale, an ARC near or  $> 1$  implies that compound has adsorption similar or greater than *S*-metolachlor. ANOVA indicated an interaction between soil and equilibration methods for ARC (data not shown). The ARC estimated for 2,4-D was in a similar range for most of the samples when soil to solution ratios were compared within each individual soil (Figure 24A). Significant differences were observed for ASE results in the Houston Black, Candor I and Arapahoe and for the batch equilibrium results in the Candor I soil series. The majority of the samples had ARC values  $\leq 0.3$  indicating similarity of 2,4-D adsorption with the  $K_{d(\text{saf})} = K_{d(\text{min})}$ . Higher ARC is an indicator that adsorption of 2,4-D is increasing in relation to the AW scale such as in the Candor I series. In this particular sample, low soil pH (4.5) probably increased 2,4-D adsorption. Similarly, the ARC calculated for atrazine resulted in a similar range of index among the batch equilibrium ratios, despite some differences by overlapping 95% confidence intervals (Figure 24B). ARC obtained with ASE equilibration was inconsistent with batch equilibrium results in the majority of samples. In the Candor I series, adsorption of atrazine was similar to *S*-metolachlor for the batch equilibrium results being the reason for the ARC close to one for this herbicide in this soil.

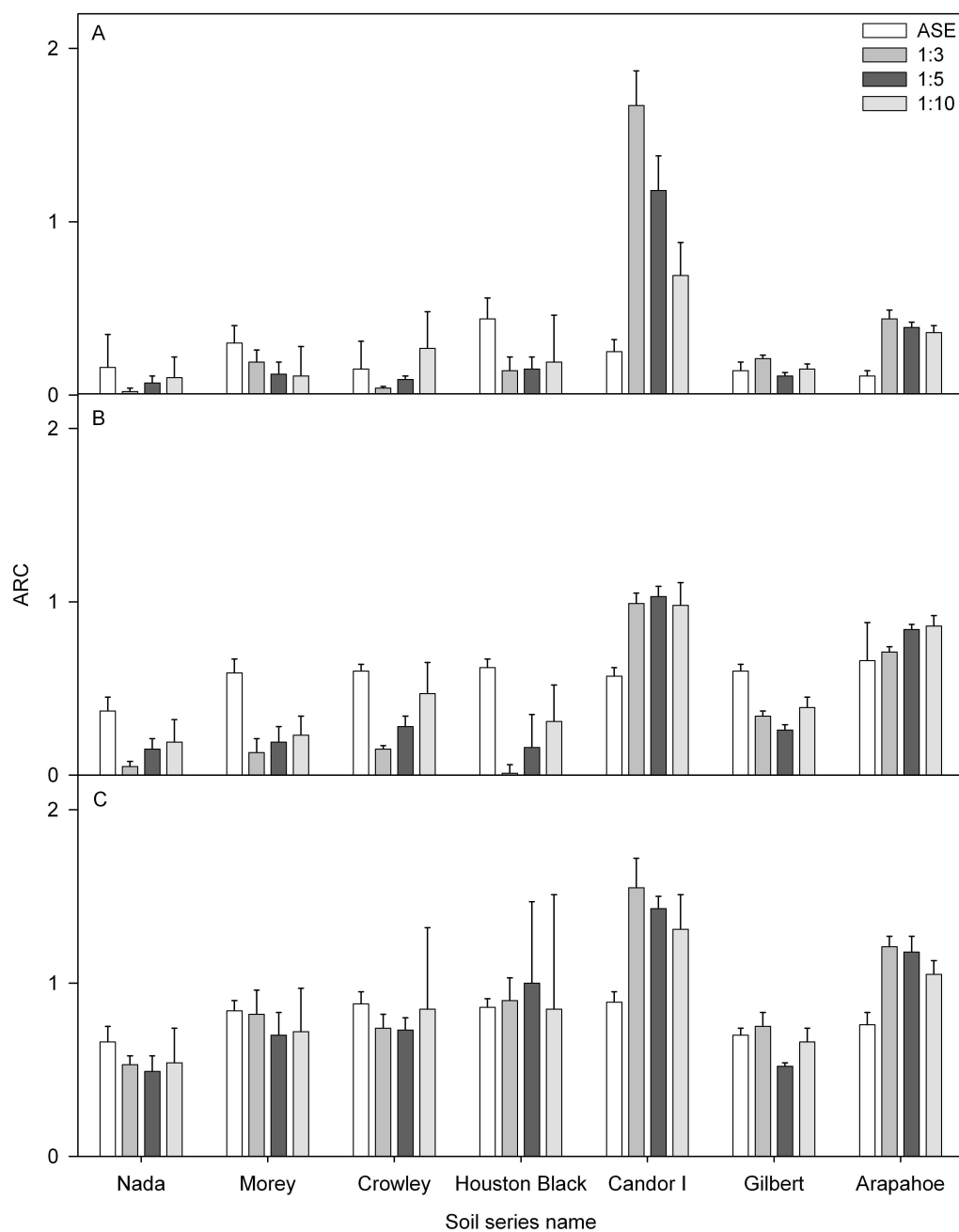

**Figure 24.** Adsorption relativity coefficient (ARC) for 2,4-D (A), atrazine (B) and clomazone (C) estimated for each soil series as a function of soil to solution ratio and ASE methodology. Index represents the relative position of each compound with relation of the adsorption windows. ARC was not calculated for *S*-metolachlor and saflufenacil as these two herbicides provided the maximum and minimum  $K_d$  values in most of the samples. Bars represent 95% confidence intervals.

Clomazone  $K_d$  values varied significantly among equilibration methods in Nada, Morey, Crowley, Houston Black, Candor I, Gilbert and Arapahoe (Figure 22). However, calculation of ARC demonstrated that  $K_d$  values for clomazone changed proportionally with expansion/contraction of the AW as relative coefficients were grouped together among soil to solution ratios for these soils (Figure 24C). Even results obtained with ASE demonstrated less discrepancy for clomazone, except for the Candor I and Arapahoe soils. For the majority of the soils, ARC values were greater than 0.5 indicating that clomazone had adsorption values approaching *S*-metolachlor.

## CONCLUSIONS

In summary, results from this study indicated that 0.01 M of  $\text{CaCl}_2$  affected adsorption results of saflufenacil, 2,4-D, clomazone and *S*-metolachlor. Atrazine adsorption was not altered in any of the soil samples by adding the  $\text{CaCl}_2$  salt. Adsorption values of 2,4-D increased in every soil sample with pH lower than 7.0 when batch equilibration solutions were prepared with  $\text{CaCl}_2$ . Guidelines indicating use of  $\text{CaCl}_2$  should be reviewed and pure water should be considered as part of a more accurate method of soil adsorption determination. Tandem quadrupole mass spectrometry detection demonstrated to be an alternative to liquid scintillation counting. Quantification using mass spectrometry allowed for removal of  $\text{CaCl}_2$  solutions, simultaneous use of multiple analytical standards and quantification of field-applied rates. There were multiple patterns for the adsorption values in the range of soil and pesticides tested as a function of equilibration methods. Individual  $K_d$  values were



affected by the soil to solution ratios, but responses were dependent of the soil-pesticide interaction. Generally, soil and pesticide interaction that resulted in  $K_d < 2 \text{ mL g}^{-1}$  were not affected by soil to solution ratios. The use of reference compounds during the estimation of  $K_d$  values allowed for calculation of an adsorption window (AW). The adsorption window reflected the interaction of the matrix with compounds representing several chemical families and allowed for true comparison of  $K_d$  values across soils. Furthermore, AW was used to calculate the adsorption relativity coefficient (ARC), which indicated the  $K_d$  relative position of a particular compound within the AW range. ARC corrected for the variation of individual  $K_d$  values encountered at the different soil to solution ratio used in the batch equilibrium, especially considering compounds that were frequently affected by equilibration methods such as clomazone. Therefore, the use of reference compounds and an adsorption window concept can be adopted for conduction of adsorption studies to correct for methodological variation and to make feasible comparisons within and among studies. Adsorption values obtained with ASE were generally higher than those found with the batch equilibrium, with higher variability and some discrepancy after correcting for ARC.

## CHAPTER VII

### SUMMARY AND CONCLUSIONS

The studies described in this document investigated agronomic and environmental aspects associated with the development of saflufenacil for the rice production environment.

During two years of research, none or minimal rice injury was observed from PRE application of saflufenacil alone, indicating that rice was consistently tolerant to this herbicide up to 200 g ha<sup>-1</sup>. Combination of saflufenacil up to 100 g ha<sup>-1</sup> with an intermediate rate of clomazone (392 g ha<sup>-1</sup>) can be a potential mixture for PRE application in rice regarding crop tolerance. Intense injury (68%) was noted with combinations of clomazone (505 g ha<sup>-1</sup>) applied PRE and saflufenacil (50 g ha<sup>-1</sup>) applied POST in early evaluations. However, saflufenacil rates up to 25 g ha<sup>-1</sup> applied POST following an intermediate rate of clomazone resulted in initial rice injury that rapidly diminished. Rice recovered over time for herbicide treatments applied PRE and POST in both years. Consequently, rice yield was not adversely affected by any of the saflufenacil rates applied either PRE or POST in a clomazone weed control program in light-textured soils.

In combination with imazethapyr, rice injury increased with doses of saflufenacil and injury up to 83% was observed at early evaluations when 50 g ha<sup>-1</sup> was applied EPOST. Subsequent evaluations indicated less injury over time demonstrating rice recovery from saflufenacil treatments. No injury was observed in the imazethapyr

treatment alone. Rice plants seemed to recover faster from LPOST application injury than EPOST. Hemp sesbania control was  $\geq 88\%$  in all saflufenacil treatments in evaluations conducted before harvest indicating effective control throughout the growing season ( $> 90\%$  on average). Burning injury from saflufenacil displayed a more rapid visual response and control of red rice when compared with imazethapyr alone, especially early in the season. However, in evaluations conducted before harvest, red rice control was 100% for all treated plots containing imazethapyr in both years. Therefore, imazethapyr control of red rice was not adversely affected by tank-mixing with saflufenacil. Although injury was significantly higher in the highest doses of saflufenacil, rice yield was not adversely altered by the herbicide treatments. Saflufenacil appears to be an effective herbicide candidate for broadleaf control in rice. As for future research, experiments should investigate the combination of saflufenacil with both the EPOST and LPOST applications of imazethapyr.

Subsequently, studies were designed to evaluate the absorption and translocation of imazethapyr in red rice and saflufenacil in hemp sesbania as a function of their POST interaction and light intensity. Imazethapyr plus saflufenacil provided greater uptake (30%) and translocation (35%) of  $^{14}\text{C}$ -imazethapyr than imazethapyr alone in the TX4 red rice, independently of the tested light intensity treatment. Similarly, acropetal movement of imazethapyr was higher 3 and 7 days after treatment in the red rice ecotype when applied with saflufenacil. These results support field observations of faster activity of imazethapyr applied with saflufenacil in red rice plants earlier in the season (Camargo et al., 2012). Under higher light intensities, imazethapyr translocated faster below the

treated leaf and root system indicating the effect of light intensity on basipetal movement of ALS inhibitors such as imazethapyr. In the hemp sesbania study, absorption of  $^{14}\text{C}$ -saflufenacil ranged from approximately 40 to 60%. Overall, imazethapyr improved absorption of saflufenacil in hemp sesbania, but uptake was dependent on light intensity treatments. Reducing light intensity resulted in greater translocation of saflufenacil in hemp sesbania. As a consequence, the two-lower light intensity treatments promoted greater acropetal and basipetal distribution of saflufenacil after 24 hours. Therefore, application of saflufenacil during cloudy days or late evenings could facilitate more thorough translocation through broadleaf weeds. Combination of saflufenacil and imazethapyr could provide a reciprocal benefit for the action of the two herbicides in TX4 red rice and hemp sesbania weeds.

Besides the agronomic aspects, saflufenacil behavior and fate in the soil needed to be investigated in the rice production ecosystem. An effective ASE method was developed to extract saflufenacil from soil. Results indicated that carbon mineralization was affected by field capacity and saturated (flooded) moisture conditions. Higher carbon mineralization was observed at field capacity indicating predominance of aerobic activity. Conversely, flooded treatments resulted in lower  $\text{CO}_2$  evolution indicating a shift to anaerobic microbial metabolism. Half-life averaged among soils was 33 and 59 days for field capacity and saturated conditions, respectively. Therefore, saflufenacil persistence in the environment was 2 to 3 times longer under flooded conditions for most of the studied series. Despite that, half-life no longer than 80 days was observed for the combination of soils and moisture treatments.

Finally, adsorption studies were developed including saflufenacil. Results indicated that 0.01 M of CaCl<sub>2</sub> affected adsorption of saflufenacil, 2,4-D, clomazone and *S*-metolachlor. Atrazine adsorption was not altered in any of the soil samples by adding the CaCl<sub>2</sub> salt. Adsorption values of 2,4-D increased in every soil sample with pH lower than 7.0 when batch equilibration solutions were prepared with CaCl<sub>2</sub>. Guidelines indicating use of CaCl<sub>2</sub> should be reviewed and pure water should be considered as part of a more accurate method of soil adsorption determination. Tandem quadrupole mass spectrometry detection demonstrated to be an alternative to liquid scintillation counting. Quantification using mass spectrometry allowed for removal of CaCl<sub>2</sub> solutions, simultaneous use of multiple analytical standards and quantification of field-applied rates.

There were multiple patterns for the adsorption values in the range of soil and pesticides tested as a function of equilibration methods. Adsorption values were affected by soil to solution ratios, particularly when the soil-pesticide interaction resulted in  $K_d$  values > than 2 mL g<sup>-1</sup>. The use of reference compounds during the estimation of  $K_d$  values allowed for calculation of an adsorption window (AW). The adsorption window reflected the interaction of the matrix with compounds representing several chemical families and allowed for true comparison of  $K_d$  values across soils. Furthermore, AW was used to calculate the adsorption relativity coefficient (ARC), which indicated the  $K_d$  relative position of a particular compound within the AW range. ARC corrected for the variation of individual  $K_d$  values encountered at the different soil to solution ratio used in the batch equilibrium, especially considering compounds that were frequently affected

by equilibration methods such as clomazone. Therefore, the use of reference compounds and an adsorption window concept can be adopted for conduction of adsorption studies to correct for methodological variation and to make feasible comparisons within and among studies. Adsorption values obtained with ASE were generally higher than those found with the batch equilibrium, with higher variability and some discrepancy after correcting for ARC.

## REFERENCES

- Abate, G., Penteado, J.C., Cuzzi, J.D., Vitti, G.C., Lichtig, J., Masini, J.C., 2004. Influence of humic acid on adsorption and desorption of atrazine, hydroxyatrazine, deethylatrazine, and deisopropylatrazine onto a clay-rich soil sample. *J. Agric. Food Chem.* 52, 6747-6754.
- Agostinetto, D., Galon, L., Silva, J.M.B.V., Tironi, S.P., Andres, A., 2010. Interference and economic weed threshold (Ewt) of barnyardgrass on rice as a function of crop plant arrangement. *Planta Daninha* 28, 993-1003.
- Ahern, C.R., Baker, D.E., Aitken, R.L., 1995. Models for relating pH measurements in water and calcium-chloride for a wide-range of pH, soil types and depths. *Plant Soil.* 171, 47-52.
- Alister, C.A., Araya, M.A., Kogan, M., 2011. Adsorption and desorption variability of four herbicides used in paddy rice production. *J. Environ. Sci. Heal. B* 46, 62-68.
- Ashigh, J., Hall, J.C., 2010. Bases for interactions between saflufenacil and glyphosate in plants. *J. Agric. Food Chem.* 58, 7335-7343.
- Aureus, M., Reyes, L., 2011. Rice for future generations. *Rice Today*, p. 12-15.
- Avila, L.A., Lee, D.J., Senseman, S.A., McCauley, G.N., Chandler, J.M., Cothren, J.T., 2005a. Assessment of acetolactate synthase (ALS) tolerance to imazethapyr in red rice ecotypes (*Oryza spp*) and imidazolinone tolerant/resistant rice (*Oryza sativa*) varieties. *Pest Manag. Sci.* 61, 171-178.

- Avila, L.A., Senseman, S.A., McCauley, G.N., Chandler, J.M., O'Barr, J.H., 2005b. Effect of flood timing on red rice (*Oryza spp.*) control with imazethapyr applied at different dry-seeded rice growth stages. *Weed Technol.* 19, 476-480.
- Baglieri, A., Gennari, M., Arena, M., Abbate, C., 2011. The adsorption and degradation of chlorpyrifos-methyl, pendimethalin and metalaxyl in solid urban waste compost. *J. Environ. Sci. Heal. B* 46, 454-460.
- Bailey, G.W., White, J.L., 1964. Review of adsorption and desorption of organic pesticides by soil colloids with implications concerning pesticide bioactivity. *J. Agric. Food Chem.* 12, 324-332.
- Baker, J.R., Mihelcic, J.R., Luehrs, D.C., Hickey, J.P., 1997. Evaluation of estimation methods for organic carbon normalized sorption coefficients. *Water Environ. Res.* 69, 136-145.
- Baltazar, A.M., Smith, R.J., 1994. Propanil-resistant barnyardgrass (*Echinochloa crus-galli*) control in rice (*Oryza sativa*). *Weed Technol.* 8, 576-581.
- Belyaeva, O.B., Litvin, F.F., 2009. Pathways of formation of pigment forms at the terminal photobiochemical stage of chlorophyll biosynthesis. *Biochemistry-Moscow* 74, 1535-1544.
- Bennett, C., 2008. Rice Demand Continues Strong Worldwide in 2008, vol. 25. Southwest Farm Press, p. 11-11.
- Bermudez-Couso, A., Fernandez-Calvino, D., Pateiro-Moure, M., Novoa-Munoz, J.C., Simal-Gandara, J., Arias-Estevez, M., 2011. Adsorption and desorption kinetics of carbofuran in acid soils. *J. Hazard. Mater.* 190, 159-167.



- Beyers, J.T., Smeda, R.J., Johnson, W.G., 2002. Weed management programs in glufosinate-resistant soybean (*Glycine max*). *Weed Technol.* 16, 267-273.
- Briggs, G.G., 1990. Predicting the behaviour of pesticides in soil from their physical and chemical properties. *Phil. Trans. R. Soc. Land. B* 329, 375-382.
- Brown, D.S., Flagg, E.W., 1981. Empirical prediction of organic pollutant sorption in natural sediments. *J. Environ. Qual.* 10, 382-386.
- Burgos, N.R., Norsworthy, J.K., Scott, R.C., Smith, K.L., 2008. Red rice (*Oryza sativa*) status after 5 years of imidazolinone-resistant rice technology in Arkansas. *Weed Technol.* 22, 200-208.
- Camargo, E.R., Senseman, S.A., McCauley, G.N., Guice, J.B., 2011. Rice tolerance to saflufenacil in a clomazone weed control program. *Int. J. Agron.*, doi:10.1155/2011/402461.
- Camargo, E.R., Senseman, S.A., McCauley, G.N., Guice, J.B., 2012. Rice (*Oryza sativa* L.) response and weed control from tank-mix applications of saflufenacil and imazethapyr. *Crop Prot.* 31, 94-98.
- Carbo, L., Martins, E.L., Dores, E.F.G.C., Spadotto, A.A., Weber, O.L.S., DeLamonica-Freire, E.M., 2007. Acetamiprid, carbendazim, diuron and thiamethoxam sorption in two Brazilian tropical soils. *J. Environ. Sci. Heal. B* 42, 499-507.
- CDMS, Crop Data Management Systems, 2011. Sharpen supplemental label for preplant use in rice. <http://www.cdms.net/LDat/ld99E010.pdf>. (accessed 15.12.2011)
- Chowdhury, N., Burns, R.G., Marschner, P., 2011. Recovery of soil respiration after drying. *Plant Soil* 348, 269-279.

- Cleveland, C.B., 1996. Mobility assessment of agrichemicals: current laboratory methodology and suggestions for future directions. *Weed Technol.* 10, 157-168.
- Counce, P.A., Keisling, T.C., Mitchell, A.J., 2000. A uniform, objective, and adaptive system for expressing rice development. *Crop Sci.* 40, 436-443.
- Croughan, T.P., Utomo, H.S., Sanders, D.E., Braverman, M.P., 1996. Herbicide-resistant rice offers potential solution to red rice problem. *La. Agric.* 39, 10-12.
- Das, A., Uchimiya, H., 2002. Oxygen stress and adaptation of a semi-aquatic plant: rice (*Oryza sativa*). *J. Plant Res.* 115, 315-320.
- Davis, V.M., Kruger, G.R., Young, B.G., Johnson, W.G., 2010. Fall and spring preplant herbicide applications influence spring emergence of glyphosate-resistant horseweed (*Conyza canadensis*). *Weed Technol.* 24, 11-19.
- de Wilde, T., Mertens, J., Spanoghe, P., Ryckeboer, J., Jaeken, P., Springael, D., 2008. Sorption kinetics and its effects on retention and leaching. *Chemosphere* 72, 509-516.
- DeLaune, R.D., Devai, I., Mulbah, C., Crozier, C., Lindau, C.W., 1997. The influence of soil redox conditions on atrazine degradation in wetlands. *Agr. Ecosyst. Environ.* 66, 41-46.
- Delle Site, A., 2001. Factors affecting sorption of organic compounds in natural sorbent/water systems and sorption coefficients for selected pollutants. A review. *J. Phys. Chem. Ref. Data* 30, 187-439.

- Detting, M.D., Yavitt, J.B., Zinder, S.H., 2006. Control of organic carbon mineralization by alternative electron acceptors in four peatlands, central New York State, USA. *Wetlands* 26, 917-927.
- Ding, Y.J., Zhang, W.H., Gu, C., Xagorarakis, I., Li, H., 2011. Determination of pharmaceuticals in biosolids using accelerated solvent extraction and liquid chromatography/tandem mass spectrometry. *J. Chromatogr. A* 1218, 10-16.
- Dodla, S.K., Wang, J.J., Delaune, R.D., Breitenbeck, G., 2009. Carbon gas production under different electron acceptors in a freshwater marsh soil. *Chemosphere* 76, 517-522.
- Doran, G., Eberbach, P., Helliwell, S., 2009. Sorption and degradation of fipronil in flooded anaerobic rice soils. *J. Agr. Food Chem.* 57, 10296-10301.
- Duke, S.O., Lydon, J., Becerril, J.M., Sherman, T.D., Lehnen, L.P., Jr., Matsumoto, H., 1991. Protoporphyrinogen oxidase-inhibiting herbicides. *Weed Sci.* 39, 465-473.
- Duwig, C., Muller, K., Vogeler, I., 2006. 2,4-D movement in allophanic soils from two contrasting climatic regions. *Commun. Soil Sci. Plant Anal.* 37, 2841-2855.
- EPA, Environmental Protection Agency, 2009. Pesticides fact sheet: saflufenacil. <http://www.epa.gov/opprd001/factsheets/saflufenacil.pdf> (accessed 12.03.2012)
- EPA. Environmental Protection Agency, 2007. Pesticides: Data requirements for conventional chemicals. <http://www.epa.gov/fedrgstr/EPA-PEST/2007/October/Day-26/p20826.htm> (accessed 15.11.2011)

Estorninos, L.E.Jr., Gealy, D.R., Gbur, E.E., Talbert, R.E., McClelland, M.R., 2005.

Rice and red rice interference. II. Rice response to population densities of three red rice (*Oryza sativa*) ecotypes. *Weed Sci.* 53, 683-689.

Eubank, T.W., Nandula, V.K., Reddy, K.N., Shaw, D.R., 2010. Influence of saflufenacil on the absorption and translocation of <sup>14</sup>C-glyphosate in glyphosate-resistant and -susceptible horseweed (*Conyza canadensis*). *Proc. South. Weed Sci. Soc.* 63, 70-70.

FAO, Food and Agriculture Organization of United Nations, 2011. Statistics, FAOSTAT-Agriculture. <http://faostat.fao.org/site/567/default.aspx> (accessed 20.07.11)

Farmer, W.J., Aochi, Y., 1974. Picloram sorption by soils. *Soil Sci. Soc. Am J.* 38, 418-423.

Frihauf, J.C., Stahlman, P.W., Al-Khatib, K., 2010a. Saflufenacil absorption and translocation in winter wheat (*Triticum aestivum* L.). *Pestic. Biochem. Physiol.* 98, 243-247.

Frihauf, J.C., Stahlman, P.W., Geier, P.W., 2010b. Winter wheat and weed response to postemergence saflufenacil alone and in mixtures. *Weed Technol.* 24, 262-268.

Frihauf, J.C., Stahlman, P.W., Geier, P.W., Peterson, D.E., 2010c. Winter annual broadleaf weeds and winter wheat response to postemergence application of two saflufenacil formulations. *Weed Technol.* 24, 416-424.

Gealy, D.R., Black, H.L., 1999. Effect of imazethapyr on several red rice (*Oryza sativa* L.) accessions and rice lines. *Proc. South. Weed Sci. Soc.* 52, 211-211.

- Geier, P.W., Stahlman, P.W., Charvat, L.D., 2009. Dose responses of five broadleaf weeds to saflufenacil. *Weed Technol.* 23, 313-316.
- Gentili, A., Perret, D., Marchese, S., Sergi, M., Olmi, C., Curini, R., 2004. Accelerated solvent extraction and confirmatory analysis of sulfonamide residues in raw meat and infant foods by liquid chromatography electrospray tandem mass spectrometry. *J. Agr. Food Chem.* 52, 4614-4624.
- Grossmann, K., Hutzler, J., Caspar, G., Kwiatkowski, J., Brommer, C.L., 2011. Saflufenacil (Kixor<sup>TM</sup>): biokinetic properties and mechanism of selectivity of a new protoporphyrinogen ix oxidase inhibiting herbicide. *Weed Sci.* 59, 290-298.
- Grossmann, K., Niggeweg, R., Christiansen, N., Looser, R., Ehrhardt, T., 2010. The herbicide saflufenacil (Kixor<sup>TM</sup>) is a new inhibitor of protoporphyrinogen IX oxidase activity. *Weed Sci.* 58, 1-9.
- Hart, S.E., Wax, L.M., 1996. Dicamba antagonizes grass weed control with imazethapyr by reducing foliar absorption. *Weed Technol.* 10, 828-834.
- Hess, F.D., 2000. Light-dependent herbicides: an overview. *Weed Sci.* 48, 160-170.
- Hixson, A.C., 2008. Soil properties affect simazine and saflufenacil fate, behavior, and performance, 226 pp.
- Hong, Y.G., Gu, J.D., 2009. Bacterial anaerobic respiration and electron transfer relevant to the biotransformation of pollutants. *Int. Biodeter. Biodegr.* 63, 973-980.
- Hossain, M.B., Barry-Ryan, C., Martin-Diana, A.B., Brunton, N.P., 2011. Optimisation of accelerated solvent extraction of antioxidant compounds from rosemary (*Rosmarinus officinalis* L.), marjoram (*Origanum majorana* L.) and oregano

- (*Origanum vulgare* L.) using response surface methodology. Food Chem. 126, 339-346.
- Jabusch, T.W., Tjeerdema, R.S., 2006. Microbial degradation of penoxsulam in flooded rice field soils. J. Agr. Food Chem. 54, 5962-5967.
- Jacobs, J.M., Jacobs, N.J., 1993. Porphyrin accumulation and export by isolated barley (*Hordeum vulgare*) plastids: effect of diphenyl ether herbicides. Plant Physiol. 101, 1181-1188.
- Jacobs, J.M., Jacobs, N.J., Sherman, T.D., Duke, S.O., 1991. Effect of diphenyl ether herbicides on oxidation of protoporphyrinogen to protoporphyrin in organellar and plasma membrane enriched fractions of barley. Plant Physiol. 97, 197-203.
- Kah, M., Brown, C.D., 2007. Changes in pesticide adsorption with time at high soil to solution ratios. Chemosphere 68, 1335-1343.
- Karickhoff, S.W., Brown, D.S., Scott, T.A., 1979. Sorption of hydrophobic pollutants on natural sediments. Water Res. 13, 241-248.
- Kennedy, D., 2002. The importance of rice. Science 296, 13-13.
- Knezevic, S.Z., Datta, A., Scott, J., Charvat, L.D., 2010. Tolerance of winter wheat (*Triticum aestivum* L.) to pre-emergence and post-emergence application of saflufenacil. Crop Prot. 29, 148-152.
- Köcher, H., 1983. Influence of the light on physiological effects of the herbicide Hoe 39866. Aspect Appl. Biol. 4, 227-234.
- Koskinen, W.C., Cheng, H.H., 1983. Effects of experimental variables on 2,4,5-T adsorption-desorption in soil. J. Environ. Qual. 12, 325-330.

- Krutz, L.J., Senseman, S.A., McInnes, K.J., Hoffman, D.W., Tierney, D.P., 2004. Adsorption and desorption of metolachlor and metolachlor metabolites in vegetated filter strip and cultivated soil. *J. Environ. Qual.* 33, 939-945.
- Lancaster, S.H., Haney, R.L., Senseman, S.A., Kenerley, C.M., Hons, F.M., 2008. Microbial degradation of fluometuron is influenced by Roundup WeatherMAX. *J. Agric. Food Chem.* 56, 8588-8593.
- Lancaster, S.H., Senseman, S.A., Carson, K.H., 2007. Accelerated solvent extraction of fluometuron from selected soils. *J. AOAC Int.* 90, 1142-1145.
- Lee, D.J., Senseman, S.A., O'Barr, J.H., Chandler, J.M., Krutz, L.J., McCauley, G.N., Kuk, Y.I., 2004. Soil characteristics and water potential effects on plant-available clomazone in rice. *Weed Sci.* 52, 310-318.
- Lee, H.J., Duke, M.V., Duke, S.O., 1993. Cellular localization of protoporphyrinogen-oxidizing activities of etiolated barley (*Hordeum vulgare* L.) leaves: relationship to mechanism of action of protoporphyrinogen oxidase-inhibiting herbicides. *Plant Physiol.* 102, 881-889.
- Lehnen, L.P., Sherman, T.D., Becerril, J.M., Duke, S.O., 1990. Tissue and cellular localization of acifluorfen-induced porphyrins in cucumber cotyledons. *Pestic. Biochem. Physiol.* 37, 239-248.
- Li, G.X., Li, L.F., Yang, R.B., Guo, Z.Y., Liao, X.Y., 2004. Clomazone dissipation, adsorption and translocation in four paddy topsoils. *J. Environ. Sci. (Beijing, China)* 16, 678-682.

- Liebl, R.A., Walter, H., Bowe, S.J., Holt, T.J., Westberg, D.E., 2008. BAS 800H: a new herbicide for preplant burndown and preemergence dicot weed control. *Weed Sci. Soc. Am.* 48, 120-120.
- Liesack, W., Schnell, S., Revsbech, N.P., 2000. Microbiology of flooded rice paddies. *FEMS Microbiol. Rev.* 24, 625-645.
- Lin, B., Tan, Z., Xiao, G., Wang, M., Cong, Z., Wang, S., Tang, S., Zhou, C., Sun, Z., Wang, W., 2009. Evaluation of compositional and nutritional equivalence of genetically modified rice to conventional rice using *in situ* and *in vitro* techniques. *J. Sci. Food Agr.* 89, 1490-1497.
- Lovley, D.R., Coates, J.D., 2000. Novel forms of anaerobic respiration of environmental relevance. *Curr. Opin. Microbiol.* 3, 252-256.
- Lyon, D.J., Kniss, A.R., 2010. Proso millet tolerance to saflufenacil. *Weed Technol.* 24, 349-355.
- Ma, Q.L., Ahuja, L.R., Wauchope, R.D., Benjamin, J.G., Burgoa, B., 1996. Comparison of instantaneous equilibrium and equilibrium-kinetic sorption models for simulating simultaneous leaching and runoff of pesticides. *Soil Sci.* 161, 646-655.
- Malik, M.S., Burgos, N.R., Talbert, R.E., 2010. Confirmation and control of propanil-resistant and quinclorac-resistant barnyardgrass (*Echinochloa crus-galli*) in rice. *Weed Technol.* 24, 226-233.
- Meier, J.R., Smith, K.L., Bullington, J.A., Doherty, R.C., 2010. Program approaches for hemp sesbania (*Sesbania exaltata*) control in drill-seeded rice. *Proc. Rice Tech. Work. Group.* 33, 149-149.



- Menezes, V.G., Silva, P.R.F., Carmona, R., Rezera, F., Mariot, C.H., 1997. Red rice interference on milling yield of irrigated rice cultivars. *Ciênc. Rural* 27, 27-30.
- Mitchell, H.R., Gage, E.V., 1999. Command 3 ME: weed control in southern rice. *Proc. South. Weed Sci. Soc.* 52, 186-186.
- Moran, M., Sikkema, P.H., Hall, J.C., Swanton, C.J., 2011. Sodium safens saflufenacil applied postemergence to corn (*Zea mays*). *Weed Sci.* 59, 4-13.
- Moreale, A., Vanbladel, R., 1980. Behavior of 2,4-D in Belgian soils. *J. Environ. Qual.* 9, 627-633.
- Nelson, K.A., Renner, K.A. Penner, D., 1998. Weed control in soybean (*Glycine max*) with imazamox and imazethapyr. *Weed Sci.* 46, 587-594.
- Noldin, J.A., Chandler, J.M., Ketchersid, M.L., McCauley, G.N., 1999a. Red rice (*Oryza sativa*) biology. II. Ecotype sensitivity to herbicides. *Weed Technol.* 13, 19-24.
- Noldin, J.A., Chandler, J.M., McCauley, G.N., 1999b. Red rice (*Oryza sativa*) biology. I. Characterization of red rice ecotypes. *Weed Technol.* 13, 12-18.
- Norsworthy, J.K., Burgos, N.R., Scott, R.C., Smith, K.L., 2007. Consultant perspectives on weed management needs in Arkansas rice. *Weed Technol.* 21, 832-839.
- OECD, Organisation for Economic Co-operation and Development, 2000. OECD Guideline for the testing of chemicals 106: Adsorption/desorption using a batch equilibrium method. [http://www.epa.gov/scipoly/sap/meetings/2008/october/106\\_adsorption\\_desorption\\_using.pdf](http://www.epa.gov/scipoly/sap/meetings/2008/october/106_adsorption_desorption_using.pdf) (accessed 22.10.11)

- Ottis, B.V., O'Barr, J.H., McCauley, G.N., Chandler, J.M., 2004. Imazethapyr is safe and effective for imidazolinone-tolerant rice grown on coarse-textured soils. *Weed Technol.* 18, 1096-1100.
- Owen, L.N., Mueller, T.C., Main, C.L., Bond, J., Steckel, L.E., 2011. Evaluating rates and application timings of saflufenacil for control of glyphosate-resistant horseweed (*Conyza canadensis*) prior to planting no-till cotton. *Weed Technol.* 25, 1-5.
- Robinson, R.A., Sutherland, W.J., 2002. Post-war changes in arable farming and biodiversity in Great Britain. *J. Appl. Ecol.* 39, 157-176.
- Roy, C., Gaillardon, P., Montfort, F., 2000. The effect of soil moisture content on the sorption of five sterol biosynthesis inhibiting fungicides as a function of their physicochemical properties. *Pest Manag. Sci.* 56, 795-803.
- Saito, K., 2010. Weed pressure level and the correlation between weed competitiveness and rice yield without weed competition: an analysis of empirical data. *Field Crop Res.* 117, 1-8.
- Savant, N.K., Kibe, M.M., 1971. Influence of continuous submergence on pH, exchange acidity and pH-dependent acidity in rice soils. *Plant Soil* 35, 205-208.
- Schenck, F.J., Callery, P., Gannett, P.M., Daft, J.R., Lehotay, S.J., 2002. Comparison of magnesium sulfate and sodium sulfate for removal of water from pesticide extracts of foods. *J. AOAC Int.* 85, 1177-1180.
- Scherder, E.F., Talbert, R.E., Clark, S.D., 2004. Rice (*Oryza sativa*) cultivar tolerance to clomazone. *Weed Technol.* 18, 140-144.

- Schnurer, Y., Persson, P., Nilsson, M., Nordgren, A., Giesler, R., 2006. Effects of surface sorption on microbial degradation of glyphosate. *Environ. Sci. Technol.* 40, 4145-4150.
- Scott, R.C., Meins, K.B., Smith, K.L., 2006. Tank-mix partners with Newpath herbicide for hemp sesbania control in a Clearfield rice-production system. *Ark. Agric. Exp. Stn. Res. Ser.* 540, 225-229.
- Senseman, S.A., 2007. *Herbicide Handbook*, ninth ed. Weed Science Society of America, Lawrence, KS, 458 pp.
- Sethunat, N., Yoshida, T., 1973. Parathion degradation in submerged rice soils in Phillipines. *J. Agr. Food Chem.* 21, 504-506.
- Seybold, C.A., Mersie, W., 1996. Adsorption and desorption of atrazine, deethylatrazine, deisopropylatrazine, hydroxyatrazine, and metolachlor in two soils from Virginia. *J. Environ. Qual.* 25, 1179-1185.
- Shaner, D.L., Singh, B.K., 1993. Phytotoxicity of acetohydroxyacid synthase inhibitors is not due to accumulation of 2-ketobutyrate and or 2-aminobutyrate. *Plant Physiol.* 103, 1221-1226.
- Sikkema, P.H., Shropshire, C., Soltani, N., 2008. Tolerance of spring barley (*Hordeum vulgare* L.), oats (*Avena sativa* L.) and wheat (*Triticum aestivum* L.) to saflufenacil. *Crop Prot.* 27, 1495-1497.
- Smith, R.J.Jr., 1988. Weed thresholds in southern U.S. rice, *Oryza sativa*. *Weed Technol.* 2, 232-241.

- Soltani, N., Shropshire, C., Sikkema, P.H., 2009. Response of corn to preemergence and postemergence applications of saflufenacil. *Weed Technol.* 23, 331-334.
- Soltani, N., Shropshire, C., Sikkema, P.H., 2010. Sensitivity of leguminous crops to saflufenacil. *Weed Technol.* 24, 143-146.
- Steele, G.L., Chandler, J.M., McCauley, G.N., 2002. Control of red rice (*Oryza sativa*) in imidazolinone-tolerant rice (*O. sativa*). *Weed Technol.* 16, 627-630.
- Strebe, T.A., Talbert, R.E., 2001. Sorption and mobility of flumetsulam in several soils. *Weed Sci.* 49, 806-813.
- Taiz, L., Zeiger, E., 2002. *Plant physiology*, third ed. Sinauer Associates, Inc., Sunderland, MA, 690 pp.
- Talbert, R.E., 1986. Citation-Classic - The adsorption of some s-triazines in soils. *CC/AGR Biol. Environ.*, 24-24.
- Talbert, R.E., Burgos, N.R., 2007. History and management of herbicide-resistant barnyardgrass (*Echinochloa crus-galli*) in Arkansas rice. *Weed Technol.* 21, 324-331.
- Talbert, R.E., Fletchall, O.H., 1965. The adsorption of some s-triazines in soils. *Weeds* 13, 46-52.
- Thompson, W.M., Nissen, S.J., 2002. Influence of shade and irrigation on the response of corn (*Zea mays*), soybean (*Glycine max*), and wheat (*Triticum aestivum*) to carfentrazone-ethyl. *Weed Technol.* 16, 314-318.

- Tomco, P.L., Holstege, D.M., Zou, W., Tjeerdema, R.S., 2010. Microbial degradation of clomazone under simulated California rice field conditions. *J. Agr. Food Chem.* 58, 3674-3680.
- Unland, R.D., Al-Khatib, K., Peterson, D.E., 1999. Interactions between imazamox and diphenylethers. *Weed Sci.* 47, 462-466.
- USDA, United States Department of Agriculture, 2011. Producers, Data and Statistics, Reports by Commodity. [http://www.nass.usda.gov/Statistics\\_by\\_Subject/index.php](http://www.nass.usda.gov/Statistics_by_Subject/index.php) (accessed 20.07.11)
- Vaezi, F., Sanders, R.S., Masliyah, J.H., 2011. Flocculation kinetics and aggregate structure of kaolinite mixtures in laminar tube flow. *J. Coll. Interf. Sci.* 355, 96-105.
- Van der Linden, A.M.A., Tiktak, A., Boesten, J.J.T.I., Leijnse, A., 2009. Influence of pH-dependent sorption and transformation on simulated pesticide leaching. *Sci. Total Environ.* 407, 3415-3420.
- Vasquez, M.E., Holstege, D.M., Tjeerdema, R.S., 2011. Aerobic versus anaerobic microbial degradation of etofenprox in a california rice field soil. *J. Agr. Food Chem.* 59, 2486-2492.
- Vaughan, L.K., Ottis, B.V., Prazak Havey, A.M., Bormans, C.A., Sneller, C., Chandler, J.M., Park, W.D., 2001. Is all red rice found in commercial rice really *Oryza sativa*? *Weed Sci.* 49, 468-476.
- Villaverde, J., Kahl, M., Brown, C.D., 2008. Adsorption and degradation of four acidic herbicides in soils from southern Spain. *Pest Manag. Sci.* 64, 703-710.

- Waggoner, B.S., Mueller, T.C., Bond, J.A., Steckel, L.E., 2011. Control of glyphosate-resistant horseweed (*Conyza canadensis*) with saflufenacil tank mixtures in no-till cotton. *Weed Technol.* 25, 310-315.
- Walker, A., Jurado-Exposito, M., 1998. Adsorption of isoproturon, diuron and metsulfuron-methyl in two soils at high soil:solution ratios. *Weed Res.* 38, 229-238.
- Walter, M., Marchezan, E., Avila, L.A., 2008. Rice: composition and nutritional characteristics. *Ciênc. Rural* 38, 1184-1192.
- Wauchope, R.D., Yeh, S., Linders, J.B.H.J., Kloskowski, R., Tanaka, K., Rubin, B., Katayama, A., Kordel, W., Gerstl, Z., Lane, M., Unsworth, J.B., 2002. Pesticide soil sorption parameters: theory, measurement, uses, limitations and reliability. *Pest Manag. Sci.* 58, 419-445.
- Way, M.O., 2010. Texas rice production guidelines. Texas AgriLife Research, Texas AgriLife Extension, and United States Department of Agriculture, Beaumont, TX, 76 pp.
- Weber, J.B., 1993. Ionization and sorption of fomesafen and atrazine by soils and soil constituents. *Pestic. Sci.* 39, 31-38.
- Weber, J.B., Wilkerson, G.G., Linker, H.M., Wilcut, J.W., Leidy, R.B., Senseman, S., Witt, W.W., Barrett, M., Vencill, W.K., Shaw, D.R., Mueller, T.C., Miller, D.K., Brecke, B.J., Talbert, R.E., Peeper, T.F., 2000. A proposal to standardize soil/solution herbicide distribution coefficients. *Weed Sci.* 48, 75-88.
- Weber, J.B., Wilkerson, G.G., Reinhardt, C.F., 2004. Calculating pesticide sorption coefficients ( $K_d$ ) using selected soil properties. *Chemosphere* 55, 157-166.

- Webster, E.P., Baldwin, F.L., Dillon, T.L., 1999. The potential for clomazone use in rice (*Oryza sativa*). *Weed Technol.* 13, 390-393.
- Webster, T., 2000. Weed survey - southern states - grass crops subsection. *Proc. South. Weed Sci. Soc.* 53, 247-274.
- WeedScience, 2012. International survey of herbicide resistant weeds.  
<http://www.weedscience.org>. (accessed 10.01.12)
- Wesley, M.T., Shaw, D.R. 1992. Interactions of diphenylether herbicides with chlorimuron and imazaquin. *Weed Technol.* 6, 345-351.
- Willingham, S.D., Falkenberg, N.R., McCauley, G.N., Chandler, J.M., 2008. Early postemergence clomazone tank mixes on coarse-textured soils in rice. *Weed Technol.* 22, 565-570.
- Xie, H.S., Hsiao, A.I., Quick, W.A., 1996. Influence of temperature and light intensity on absorption, translocation, and phytotoxicity of fenoxaprop-ethyl and imazamethabenz-methyl in *Avena fatua*. *J. Plant Growth Regul.* 15, 57-62.
- Yazgan, M.S., Wilkins, R.M., Sykas, C., Hoque, E., 2005. Comparison of two methods for estimation of soil sorption for imidacloprid and carbofuran. *Chemosphere* 60, 1325-1331.
- Zhou, Q., Liu, W., Zhang, Y., Liu, K.K., 2007. Action mechanisms of acetolactate synthase-inhibiting herbicides. *Pestic. Biochem. Physiol.* 89, 89-96.

**VITA**

Name: Edinaldo Rabaioli Camargo

Address: Department of Soil and Crop Sciences  
College of Agriculture and Life Sciences  
Texas A&M University  
2474 TAMU  
College Station, TX 77843-2474

Email Address: [edinaldo\\_camargo@yahoo.com.br](mailto:edinaldo_camargo@yahoo.com.br)

Education: B.S., Agronomy, Universidade Federal de Santa Maria, 2005  
M.S., Agronomy, Universidade Federal de Santa Maria, 2007  
Ph.D., Agronomy, Texas A&M University, 2012