

DEVELOPMENT OF REAL-TIME FUEL MANAGEMENT
CAPABILITY AT THE TEXAS A&M NUCLEAR SCIENCE CENTER

A Thesis

by

NEIL AUBREY PARHAM

Submitted to the Office of Graduate Studies of
Texas A&M University
in partial fulfillment of the requirements for the degree of

MASTER OF SCIENCE

May 2010

Major Subject: Nuclear Engineering

DEVELOPMENT OF REAL-TIME FUEL MANAGEMENT
CAPABILITY AT THE TEXAS A&M NUCLEAR SCIENCE CENTER

A Thesis

by

NEIL AUBREY PARHAM

Submitted to the Office of Graduate Studies of
Texas A&M University
in partial fulfillment of the requirements for the degree of

MASTER OF SCIENCE

Approved by:

| | |
|---------------------|---------------------|
| Chair of Committee, | William Charlton |
| Committee Members, | W. Dan Reece |
| | Guergana Petrova |
| Head of Department, | Raymond J. Juzaitis |

May 2010

Major Subject: Nuclear Engineering

ABSTRACT

Development of Real-Time Fuel Management Capability at the Texas A&M Nuclear
Science Center. (May 2010)

Neil Aubrey Parham, B.S., Texas A&M University;

M.S., Texas A&M University

Chair or Advisory Committee: Dr. William Charlton

For the Texas A&M University Nuclear Science Center reactor a fuel depletion code was created to develop real-time fuel management capability. This code package links MCNP⁸ and ORIGEN2⁶ and is interfaced through a Visual Basic code. Microsoft Visual Basic was used to create a user interface and for pre-and post-processing of MCNP and ORIGEN2 output. MCNP was used to determine the flux for all fuel and control rods within the core while ORIGEN2 used this flux along with the power history to calculate buildup and depletion for tracking the fuel isotopic evolution through time. A comparison of MCNP calculated fluxes and measured flux values were used to confirm the validity of the MCNP model. A comparison to MonteBurns was used to add confidence to the correctness of the calculated fuel isotopics. All material isotopics were stored in a Microsoft Access database for integration with the Visual Basic code to allow for isotopics report generation for the Nuclear Science Center staff.

This fuel management code performs its function with reasonable accuracy. It gathers minimal information from the user and burns the core over daily operation. After

execution it stores all material data to the database for further use within NSCRFM or for isotopic report generation.

TABLE OF CONTENTS

| | Page |
|---|------|
| I. INTRODUCTION | 1 |
| I.A. Motivation and Background | 1 |
| I.B. Theory | 2 |
| I.C. NSCR History | 5 |
| I.D. Objective..... | 7 |
| II. DESCRIPTION OF THE NSCR..... | 8 |
| II.A. Mechanical Design..... | 8 |
| II.B. Core Layout | 13 |
| II.C. Fuel Rod Characteristics..... | 14 |
| II.D. Control Rod Characteristics | 18 |
| III. CODE OVERVIEW | 25 |
| III.A. NSCRFM Information Flow | 25 |
| III.B. NSCRFM Details | 26 |
| III.B.1. Interfacing with MCNP..... | 28 |
| III.B.2. Interfacing with ORIGEN2 | 29 |
| IV. CODE DETAILS..... | 31 |
| IV.A. MCNP..... | 31 |
| IV.B. ORIGEN2..... | 38 |
| IV.C. Visual Basic | 46 |
| IV.D. Code Validation | 52 |
| V. CONCLUSION..... | 61 |
| REFERENCES | 63 |
| VITA..... | 66 |

LIST OF FIGURES

| | Page |
|---|------|
| Fig. 1. NSCR layout ³ | 9 |
| Fig. 2. Plan view of the NSCR including dimensions ³ | 10 |
| Fig. 3. Pool liner showing beam ports ³ | 11 |
| Fig. 4. NSCR grid plate ³ | 12 |
| Fig. 5. Cross sectional view of NSCR | 14 |
| Fig. 6. Radial cross section of NSCR fuel rod | 17 |
| Fig. 7. Axial cross section of NSCR fuel rod | 17 |
| Fig. 8. NSCR fuel rod with thermocouples ³ | 18 |
| Fig. 9. Radial cross section of NSCR Shim Safety control rod | 21 |
| Fig. 10. Axial cross section of NSCR Shim Safety control rod | 21 |
| Fig. 11. Axial cross section of NSCR Transient control rod | 22 |
| Fig. 12. Axial cross section of NSCR Transient rod | 22 |
| Fig. 13. Radial cross section of NSCR Regulating rod | 24 |
| Fig. 14. Axial cross section of NSCR Regulating rod | 24 |
| Fig. 15. Flow chart for NSCRFM | 26 |
| Fig. 16. Main form for NSCRFM | 27 |
| Fig. 17. Infinite lattice of NSCR fuel rod | 32 |
| Fig. 18. Normalized neutron flux for 8 region NSCR fuel rod | 34 |
| Fig. 19. Lattice structure for NSCR | 35 |
| Fig. 20. Comparison of MonteBurns generated ORIGEN2 cross sections sets for ²³⁵ U .. | 40 |
| Fig. 21. Comparison of MonteBurns generated ORIGEN2 cross sections sets for ²³⁸ U .. | 41 |

| | Page |
|--|------|
| Fig. 22. Comparison of Monteburns generated ORIGEN2 cross sections sets for ^{239}Pu | 41 |
| Fig. 23. Comparison of Monteburns generated ORIGEN2 cross sections sets for ^{240}Pu | 42 |
| Fig. 24. Comparison of Monteburns generated ORIGEN2 cross sections sets for ^{166}Er | 42 |
| Fig. 25. Comparison of Monteburns generated ORIGEN2 cross sections sets for ^{167}Er | 43 |
| Fig. 26. Comparison of Monteburns generated ORIGEN2 cross sections sets for ^{135}Xe | 43 |
| Fig. 27. Comparison of Monteburns generated ORIGEN2 cross sections sets for ^{149}Sm | 44 |
| Fig. 28. Comparison of Monteburns generated ORIGEN2 cross sections sets for ^{129}I ... | 44 |
| Fig. 29. Comparison of Monteburns generated ORIGEN2 cross sections sets for ^{148}Nd | 45 |
| Fig. 30. Comparison of Monteburns generated ORIGEN2 cross sections sets for ^{137}Cs | 45 |
| Fig. 31. Main form for NSCRFM | 47 |
| Fig. 32. Window for moving fuel | 47 |
| Fig. 33. Message box prompting the user to confirm fuel movement | 48 |
| Fig. 34. Button for burnup code execution | 48 |
| Fig. 35. DOS window running MCNP5..... | 49 |
| Fig. 36. DOS window running ORIGEN2..... | 51 |
| Fig. 37. Message box informing the user NSCRFM has completed..... | 52 |
| Fig. 38. Cadmium absorption cross section ¹³ | 53 |
| Fig. 39. Water column split into 10 sections for flux tallies..... | 54 |
| Fig. 40. Burnup of ^{235}U | 59 |
| Fig. 41. Burnup of ^{239}Pu | 59 |

LIST OF TABLES

| | Page |
|------------|---|
| TABLE I | FLIP and 20/30 Specifications 15 |
| TABLE II | Fuel Isotopics for Fresh FLIP and 20/30..... 16 |
| TABLE III | NSCR Shim Safety Control Rod Material Compositions 20 |
| TABLE IV | NSCR Transient Control Rod Material Compositions..... 20 |
| TABLE V | NSCR Regulating Rod Material Compositions 23 |
| TABLE VI | Normalized 1-Group Flux for 8 Region NSCR fuel rod..... 32 |
| TABLE VII | Grams of Select Isotopes in NSCR Fuel Rod after 1500 Days versus the Number of Radial Fuel Regions..... 33 |
| TABLE VIII | Reactivity of Thermal Column..... 36 |
| TABLE IX. | Nuclides Included in Reaction Rate MCNP Calculation 37 |
| TABLE X | Thermal and Epi-Thermal Flux Comparison for Foil Measurement to MCNP Code 57 |
| TABLE XI | Reactivity of Control Rods in the NSCR 57 |
| TABLE XII | Grams of Select Isotopes from ORIGEN2 Decks Generated by NSCRFM..... 60 |

I. INTRODUCTION

I.A. Motivation and Background

Growing concern over nuclear proliferation has brought about new US policy requiring that research reactors in the US have fuels with a ^{235}U enrichment no more than twenty percent with respect to weight¹. This policy has created the need to replace research reactor fuel around the country, including the fuel for the Nuclear Science Center Reactor (NSCR) at Texas A&M University (TAMU). The NSCR is a 1 MW TRIGA reactor and has operated on fuel with an initial enrichment of 70% (by weight) since 1979. With this new fuel, an opportunity is presented to improve the fuel management capability at the facility, including better tracking of the isotopic inventory of the fuel. Accurate knowledge of the fuel inventory will allow for better management of fuel loading as well as simplifying fuel shipment procedures. Also a better knowledge of the flux in a particular irradiation location on any given day is also valuable. This can help the operators to better plan irradiation experiments and optimize radioisotope production.

The NSCR used TRIGA-FLIP² fuel designed by General Atomic. FLIP fuel consists of 9 w/o uranium, 89.5 w/o Zr-H, and 1.5 w/o erbium. The uranium in FLIP fuel is enriched to 70 w/o ^{235}U . FLIP fuel was designed by General Atomic and was first installed in the NSCR in 1973³. The fuel that replaces this is 20/30⁴ fuel also designed by General Atomics. This new 20/30 fuel with 20% ^{235}U enrichment fits into the new US policy for reactor fuel. As of September 2006, the NSCR has operated on 20/30 fuel.

This thesis follows the style of *Nuclear Science and Engineering*.

I.B. Theory

A fuel management system could be used to calculate the isotopic inventory of the fuel at regular intervals for use by research reactor staff. This calculation is based on materials, geometry, and neutron flux. Geometry and core arrangement are known characteristics of the reactor system. Beginning-of-Life (BOL) fresh fuel composition are known within some tolerance based on the fuel specifications. The neutron flux must then be calculated based on these geometries, materials, and the reactor operating power[†]. This neutron flux can then be used to calculate the isotopic composition changes in the materials in the core.

The neutron scalar flux for a reactor system can be calculated using the neutron transport equation⁵:

$$\vec{\Omega} \cdot \vec{\nabla} \psi(\vec{r}, E, \vec{\Omega}) + \Sigma_t(\vec{r}, E) \psi(\vec{r}, E, \vec{\Omega}) = \int_0^\infty dE' \frac{\nu \Sigma_f(\vec{r}, E')}{4\pi k} \phi(\vec{r}, E') + \int_0^\infty dE' \int_{4\pi} d\vec{\Omega}' \Sigma_s(\vec{r}, E' \rightarrow E, \vec{\Omega}' \rightarrow \vec{\Omega}) \psi(\vec{r}, E', \vec{\Omega}') \quad (1)$$

where ϕ is the scalar flux given by:

$$\phi = \int_{4\pi} d\vec{\Omega} \psi \quad (2)$$

where ψ is the neutron angular flux, \vec{r} is a position vector, $\vec{\Omega}$ is the solid angle, k is the critical eigenvalue for the reactor system, Σ_t is the total macroscopic cross section, $\nu \Sigma_f$ is the macroscopic fission cross section times the average number of prompt neutrons from a fission event, and Σ_s is the double differential scattering cross section for neutrons

[†] This may also depend on temperature

scattering from energy E' to E and from angle $\vec{\Omega}'$ to $\vec{\Omega}$. The macroscopic cross section is defined as follows⁵:

$$\Sigma = \sum_i N_i \sigma_i, \quad (3)$$

where the σ_i is the microscopic cross section for isotope i and N_i is the atom density for isotope i .

Given $\nu\Sigma_f$, Σ_t , and Σ_s , Equation (1) can be solved for ψ . With ψ , we can use Equation (2) to calculate $\phi(\vec{r}, E)$. These solutions are accurate for a specific time t . However, as the reactor operates the isotopic compositions of the materials in the reactor will change with time. This leads to a change in macroscopic cross sections (Σ) and this leads to a change in the solution for ψ for Equation (1). Over time, the evolving isotopics of fuel loaded into a nuclear reactor can be tracked as these changing number densities and thus the changing Σ .

The density of any isotope at any position \vec{r} within the system is given by a change rate equation. These equations define the concentration of isotope i as the sum of the production of isotope i and the loss of isotope i . The production of isotope i is given by the summation of all isotopes j which by some reaction directly produce isotope i and the decay of all isotopes j that decay to isotope i . The loss term is defined as the sum of decays of isotope i and depletion from neutron absorption:

$$\frac{dN_i(t)}{dt} = P_i - L_i \quad (4)$$

$$P_i = \sum_j N_j(t) \bar{\sigma}_{j \rightarrow i} \bar{\phi}(t) + \lambda_{j \rightarrow i} N_j(t) \quad (5)$$

$$L_i = N_i(t) \bar{\sigma}_{a,i} \bar{\phi}(t) + \lambda_i N_i(t) \quad (6)$$

Here $\bar{\sigma}$ and $\bar{\phi}$ are energy averaged cross sections and scalar fluxes respectively, λ is the decay constant for decays of isotope j to i , and N_i is the concentration of isotope i . The isotope concentration and scalar flux are per time step to account for the power history of the particular reactor modeled. The microscopic cross section used in Equation (4) is found by taking the flux weighted average over energy. We used the following for the one-group average cross sections and scalar fluxes⁶:

$$\bar{\phi} = \int_0^{\infty} dE \phi \quad (7)$$

$$\bar{\sigma} = \frac{\int dE \sigma(E) \phi(E)}{\int dE \phi(E)} \quad (8)$$

The ϕ here is the solution to Equation (2) at time t and the σ is the microscopic cross section as a function of energy.

These equations are solved by assuming that the one-group scalar flux remains constant over the time step Δt , with sufficiently small time steps this is a good approximation. We then can solve Equation (1) for ψ throughout the system at $t = 0$. There are many methods for solving the transport equation such as time method of characteristics and collision probabilities⁹ for example; however, the method that will be used in this work is a Monte Carlo estimate of the flux⁸. With a solution to the neutron transport equation, we can then calculate $\phi(t=0)$ using Equation (2). With the scalar flux, $\bar{\phi}$ we can then solve for the isotopic concentration, N_i at a new time $t_1 = t + \Delta t$. In order to allow for a larger time step Δt we will typically use a predictor correction method to solve for the isotope concentrations at this new time t_1 . With this new N_i at

time t_1 we can solve another N_i at $t_2 = t_1 + \Delta t$. We solve these equations at each time step and for all isotopes that have non zero concentrations.

I.C. NSCR History

The Texas A&M University Nuclear Science Center Reactor operated from 1962 to 1967 with MTR-type curved aluminum plate elements³. During this time frame the reactor operated with a power level of 100 kW. In 1968, the reactor was converted to General Atomic TRIGA fuel and the power was upgraded to 1.0 MW. Excess reactivity was added to the core in the form of graphite reflectors on all sides of the core, additional fuel, and fuel followed control rods to counteract the effects of fuel burnup and samarium build up in the fuel. General Atomic FLIP (Fuel Life Improvement Program) fuel replaced the standard TRIGA fuel by 1979, FLIP fuel increases the core lifetime by increasing the initial fissile uranium load in the fuel. The Nuclear Science Center Reactor core operated on this fuel until September 2006 when it received 20/30 LEU fuel.

A report was written by Parish² in 1995 on replacing the TRIGA FLIP fuel with TRIGA LEU (Low Enriched Uranium) elements. TRIGA LEU fuel consists of 20 w/o uranium, 75 w/o Zr-H, and a small amount of erbium for a more negative moderator temperature coefficient of reactivity⁷. The uranium in TRIGA LEU fuel is enriched to 20 w/o ^{235}U . Parish performed the neutronic and safety analysis for the conversion to LEU fuel and revised the Nuclear Science Center's Safety Analysis Report in order to modify the current license from the Nuclear Regulatory Commission. This work focused on determining erbium concentration for the new TRIGA LEU fuel to maintain an adequate minimum control rod shutdown margin².

Bradley Rearden performed thermal, neutronic, and accident analysis for a power increase of the Texas A&M University Nuclear Science Center Reactor in 1993¹⁰. The proposed up rate was from 1.0 MW to 1.49 MW thermal. The limiting reactor parameters were calculated with several thermal hydraulics codes, and the standard reactor accident scenarios were analyzed. The results of his work demonstrated that the power upgrade could be achieved without creating any safety hazards or restricting operation of the reactor³.

Robert Candalino studied the thermal behavior as well as the expected lifetime of the 20/30 fuel received in September 2004¹¹. This neutronic and thermal analysis was to confirm that the new fuel would stay within the safety limits set for the facility and that the core lifetime of the 20/30 fuel would be consistent with the lifetime of FLIP fuel. Candalino also verified that the control rod worths and the temperature coefficient of reactivity provide an adequate amount of negative reactivity to control the reactor over its lifetime¹¹. He modeled the NSCR with a full load of 20/30 fuel and a full load of FLIP fuel. Each model was simulated using MonteBurns⁷ to determine the criticality as a function of time so the operational lifetime could be estimated for each fuel type. It was assumed during this calculation that no fuel movements were made, resulting in a conservative estimate for the core lifetime. Simulations were run against and away from a large graphite block on the west face of the reactor (the thermal column); in each case the depletion rate for both FLIP and 20/30 was very similar. The expected lifetime of the 20/30 fuel was shown to be longer than FLIP as well in this simulation. This result is expected given that the depletion rates are similar and the 20/30 fuel has a much larger uranium load than FLIP fuel. Given the lower enrichment and larger ²³⁵U load of the

20/30 fuel, one would expect the 20/30 to produce more plutonium during operation, thus extending its lifetime some. This was observed in the simulations run by Mr. Candalino.

I.D. Objective

It is useful for the NSC to be able to track fuel isotopics throughout the life cycle of fuel rods. During the fission process some fission poisons will be produced, including ^{135}Xe and ^{149}Sm . These isotopes have large absorption cross sections¹³ that make them important for reactor operation and even more important for reactor startup. Following the evolution of fuel composition through the fuel cycle will provide concentrations of Xe and Sm, allowing for better predictions on critical rod heights based off current conditions. Other fission products become more important during the life cycle of a fuel rod for heat load, dose rate while the rod is in storage, and proliferation risk.

The Monte Carlo based tool created to track isotopics needs to handle the unique day-to-day operation of a research reactor, while remaining simple to use. The creation of this tool is the objective of this thesis.

II. DESCRIPTION OF THE NSCR

The Texas A&M Nuclear Science Center (NSCR) is a rectangular reactor using TRIGA fuel. The reactor is suspended from a bridge in an open pool of water for cooling. The bridge provides the structural support for the reactor and the control rods. The NSCR has ninety-two fuel rods and six control rods, four of these control rods are fuel followed and one is a pneumatic control rod allowing for pulsing experiments. Fig. 1 shows a cross-section view of the reactor core.

II.A. Mechanical Design

The Nuclear Science Center Reactor (NSCR) fuel and control rods are connected to a grid plate that connects via an aluminum suspension frame to the reactor bridge. The reactor is contained in a pool ~30' deep, see Fig. 2. The reactor has beam ports around the pool visible in Fig. 2 and Fig. 3. The reactor bridge provides support for the reactor core, control rod drives, and instrumentation systems. This bridge is on wheels allowing it to move in the rails along the sides of the pool. The core can be moved into the area with the beam ports and to the opposite direction to allow for irradiation of large objects in the room at far end of the pool from the beam ports. When the reactor is located at this end of the pool a window is opened for irradiation, the window can be seen in Fig. 3.

A grid plate, seen in Fig. 4, welded to an aluminum suspension frame, supports the reactor. The west side of this frame is open to allow unrestricted flow of cooling water. An aluminum stabilizer is bolted to the bottom of the grid plate for vertical support. Stainless steel guides on the bottom of this stabilizer fit between tracks on the

pool floor. This ensures accurate horizontal positioning of the core to prevent the reactor from swaying.

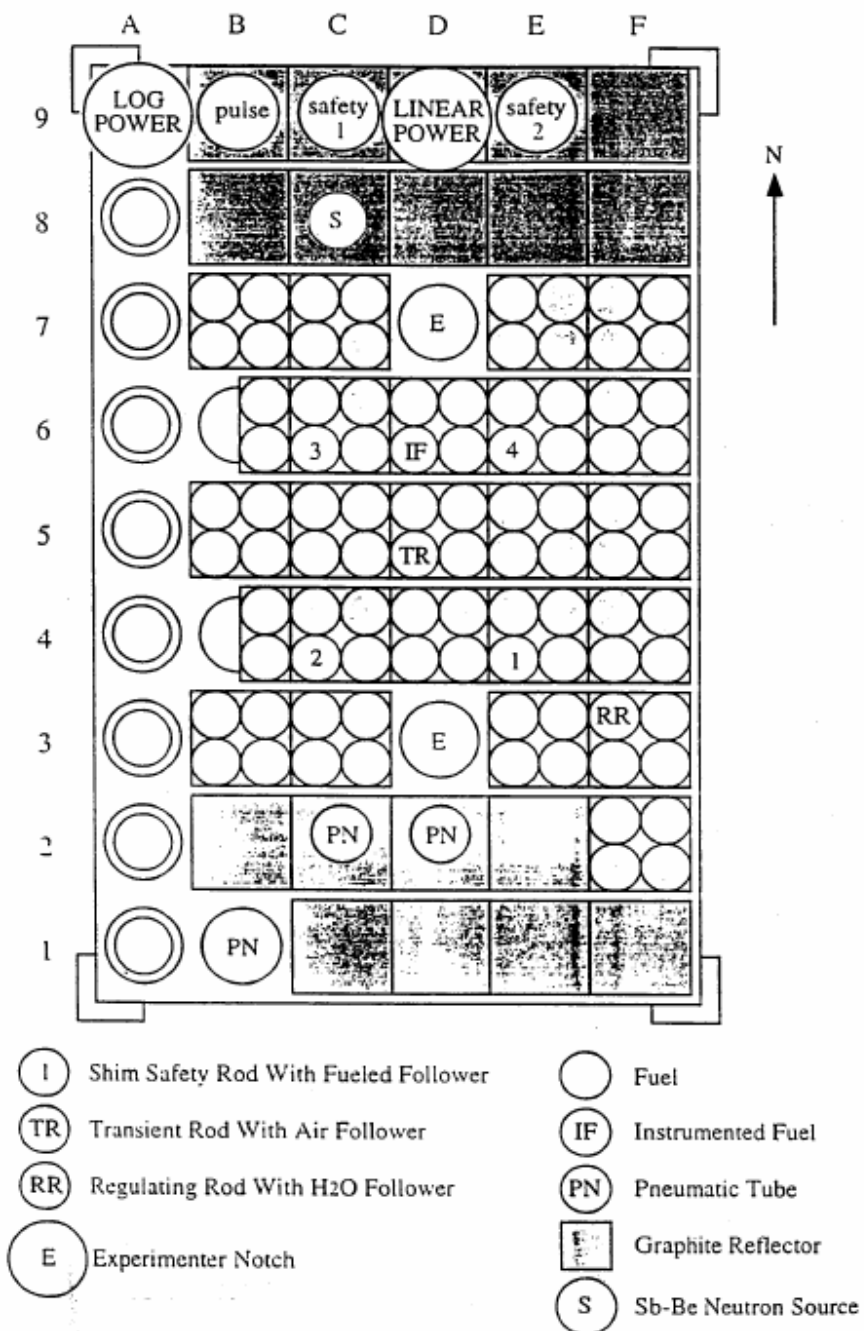

Fig. 1. NSCR layout³

The grid plate contains a 9 x 6 array of 54 holes for support of the bundled assemblies. Each hole supports one bundle containing four fuel elements or three fuel elements and one control rod.

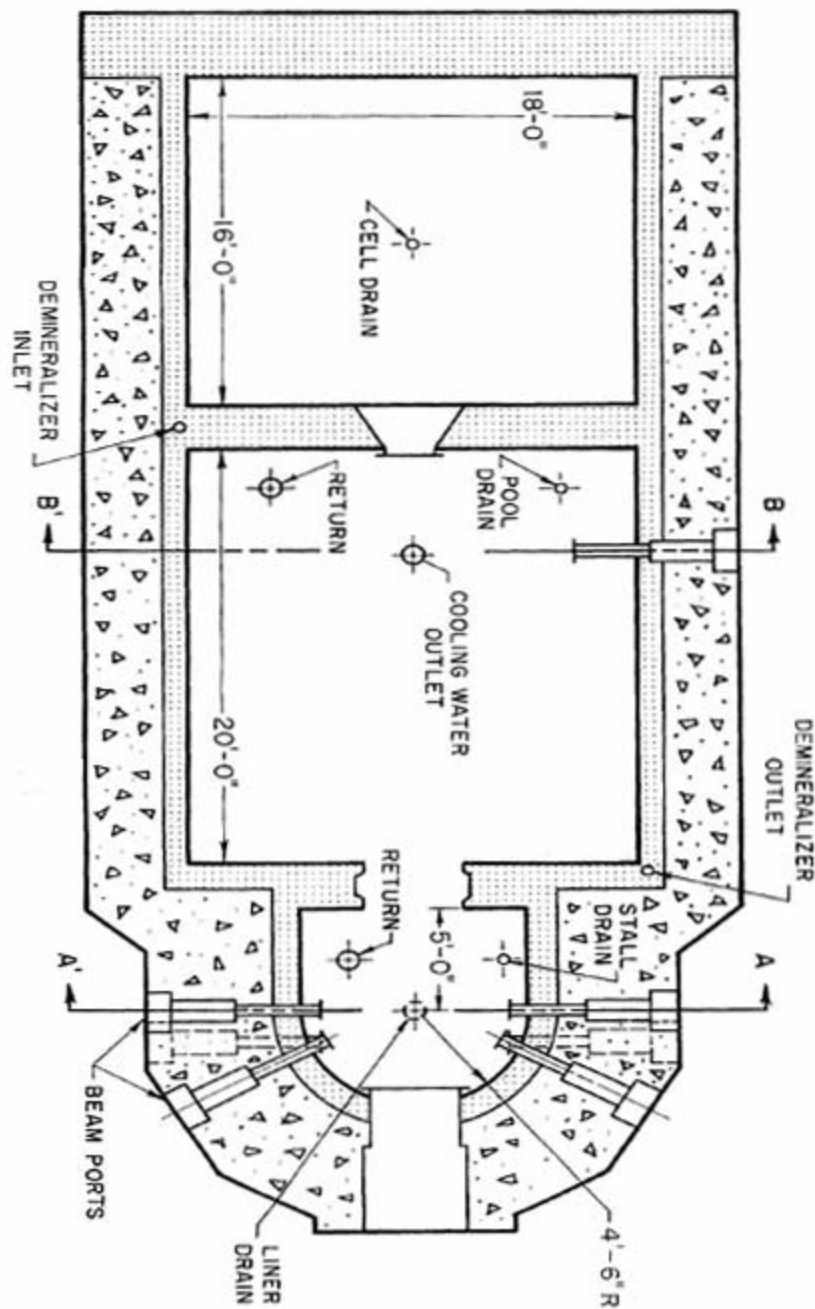

Fig. 2. Plan view of the NSCR including dimensions³

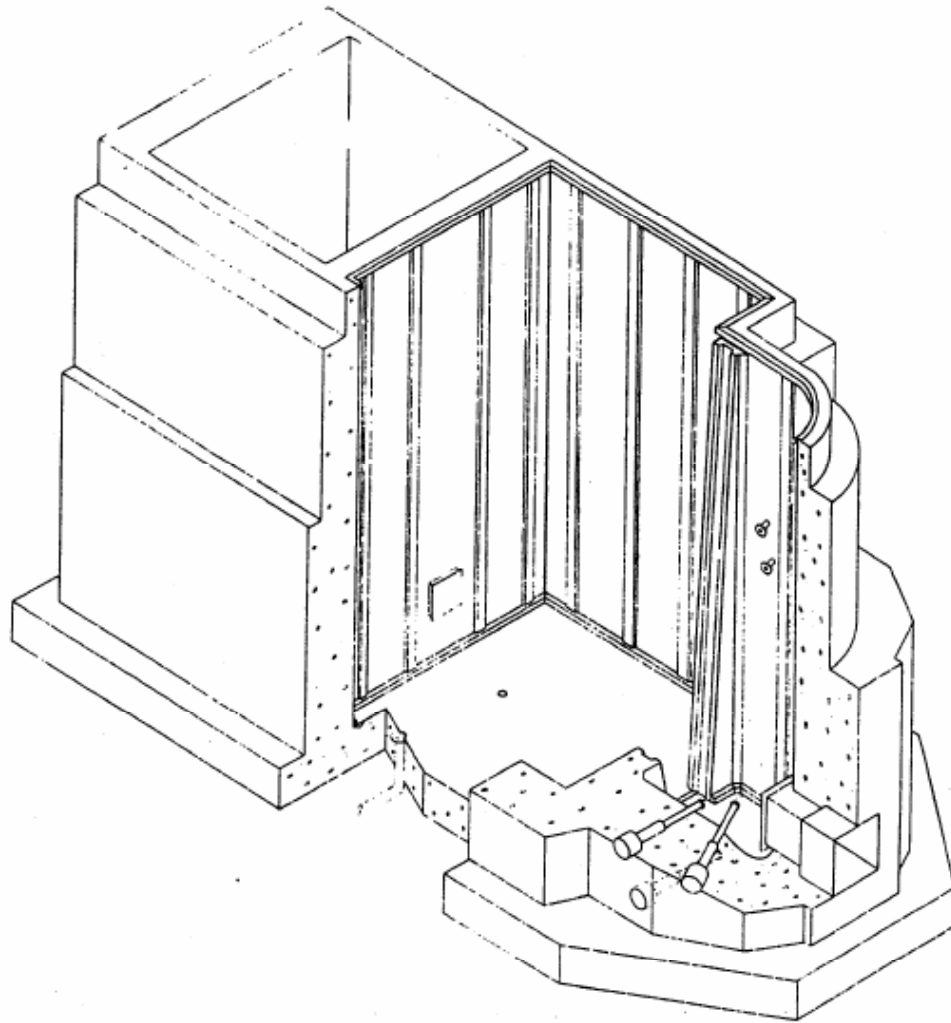

Fig. 3. Pool liner showing beam ports³

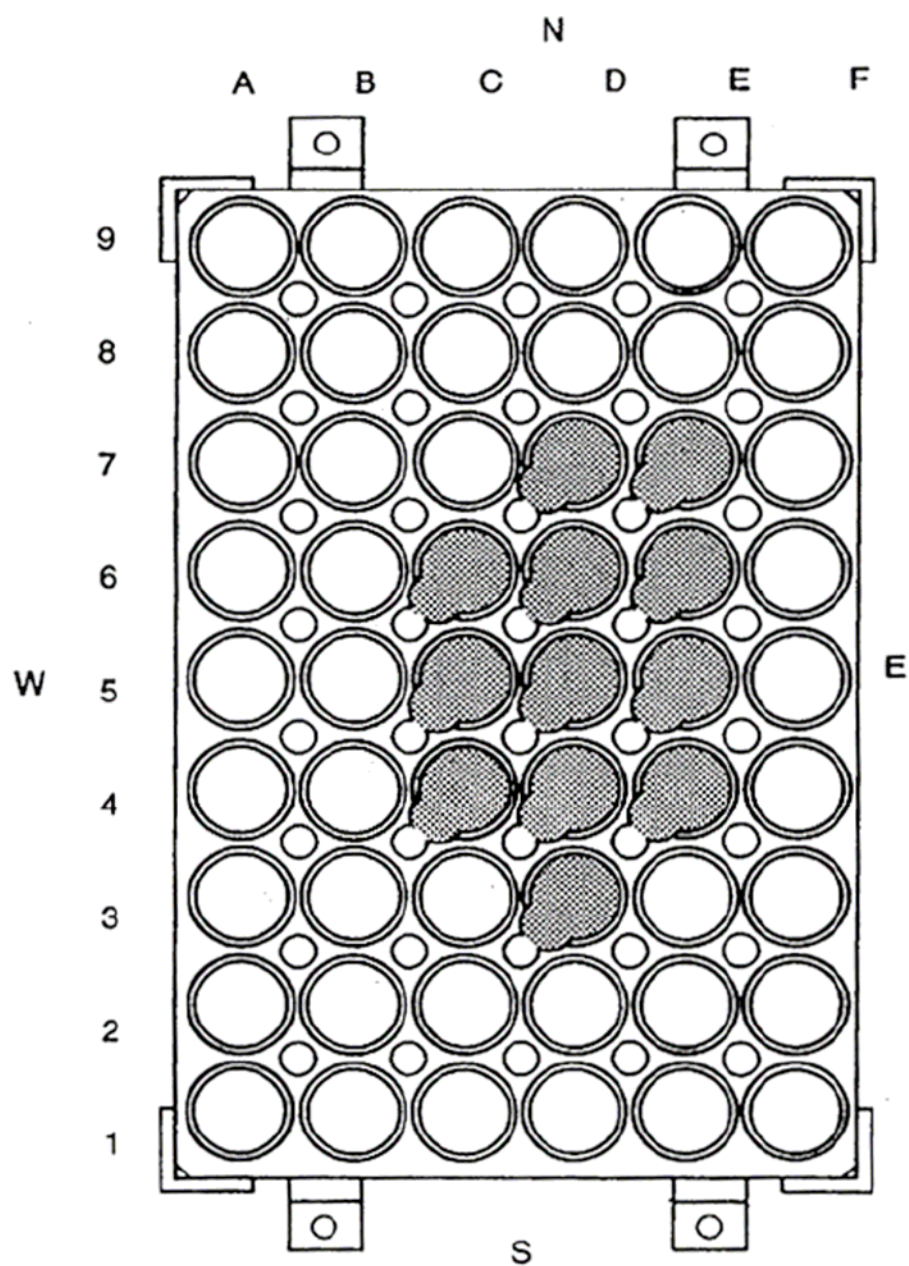

Fig. 4. NSCR grid plate³

II.B. Core Layout

Fig. 1 illustrates the core layout, where fuel rod locations, control rod locations, detector positions and internal irradiation locations are labeled. Along the column labeled 'A' are positions for irradiation located outside the core. Illustrated in Fig. 5 is the core layout used in the MCNP model, the core consists of ninety-two fuel rods, four fuel followed control rods, one control rod with an air gap for pulsing, and one smaller control rod for fine adjustments.

An electromagnetic drive mechanism moves the shim safety and regulating rods axially through the core. The shim safety rods may be operated in gang or individually. The maximum withdrawal speed² is 11.4 cm/min while the regulating rod can be moved manually or operated in automatic mode where its position is varied to maintain power. The regulating rod can move at a maximum speed of 24.4 cm/min². The transient rod is held in position by high-pressure air allowing it to be ejected from the core for pulsing experiments.

Water gaps exist on either side of the core (positions D3 and D7 in Fig. 5) for pneumatic insertion of irradiation experiments. Graphite blocks line either side of the core while a large graphite thermal column is located one inch from the west face of the core. The reactor can be moved away from this thermal column when needed.

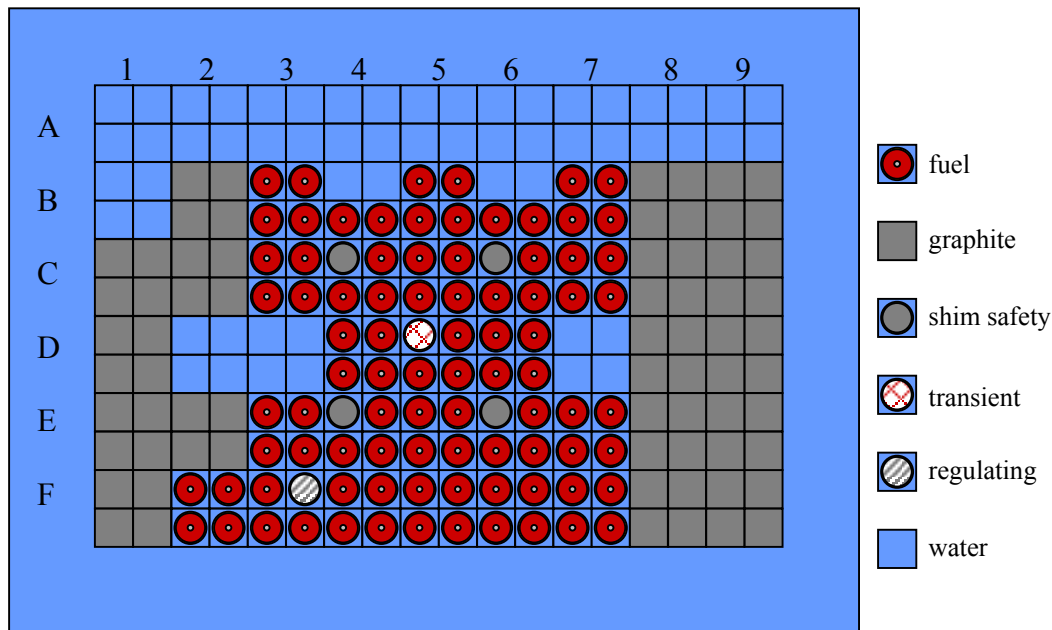

Fig. 5. Cross sectional view of NSCR

II.C. Fuel Rod Characteristics

This new TRIGA LEU fuel contains zirconium hydride as a solid moderator mixed into the fuel. A hole is drilled through the center of the fuel rod to facilitate hydriding of the zirconium uranium matrix. After this process zirconium rods are inserted into the holes and graphite slugs on the top and bottom are inserted to act as reflectors. The active fuel volume and these graphite slugs are contained within a stainless steel can and the ends are welded to top and bottom end fittings. This is illustrated in Fig. 5. Table I includes more detailed comparison of fuel specifications for FLIP and 20/30 fuel.

MCNP⁸ was used to model the NSCR. Fig. 6 illustrates, with dimensions, a planar view of the fuel rods. A stainless steel cladding surrounds the fuel with a zirconium rod in the center. Fig. 7 is an axial view of the fuel rod with dimensions, as

illustrated in Fig. 4 the graphite end plugs are modeled in MCNP. Table II gives fresh isotopics for a fuel rod as modeled in MCNP.

TABLE I
FLIP and 20/30 Specifications

| | FLIP ⁴ | 20/30 ¹⁵ |
|---------------------------|-------------------|---------------------|
| Fuel-moderator material | U-ZrH | U-ZrH |
| Uranium content | 8.5 wt% | 30 wt% |
| U-235 Content | 70% | 20% |
| U-235 Content per Element | 123g | 151g |
| Burnable Poison | Natural erbium | Natural erbium |
| Erbium content | 1.5 wt% | 0.9 wt% |
| Shape | Cylindrical | Cylindrical |
| Length of Fuel | 15 in | 15 in |
| Diameter of fuel | 1.371 in | 1.371 in |
| Cladding type | 304 SS | 304 SS |
| Cladding thickness | 0.020 in | 0.020 in |

Special instrumentation fuel elements containing three embedded thermocouples are used to measure fuel temperature during operation. The vertical locations of these thermocouples are shown in Fig. 8. One thermocouple is located at the axial center while the other two are one inch below and above the center. The sensors are placed in the radial center of the fuel. The lead out wires are contained in a stainless steel tube welded to the upper end fixture to insure a watertight seal.

TABLE II
Fuel Isotopics for Fresh FLIP and 20/30

| Material | Isotope | FLIP Fuel Atomic Density ¹⁰ (atoms/b-cm) | 20/30 Fuel Atomic Density ¹⁶ (atoms/b-cm) |
|----------------|---------|--|---|
| Zirconium Rod | Zr | 4.29090E-2 | 4.29757E-2 |
| U-ZrH | U-234 | N/A | 8.3200E-6 |
| | U-235 | 8.8384E-4 | 1.08197E-3 |
| | U-236 | N/A | 1.2100E-5 |
| | U-238 | 3.78780E-4 | 4.32127E-3 |
| | Zr | 3.39770E-2 | 3.22796E-2 |
| | H | 5.4364E-2 | 4.91576E-2 |
| | Er-166 | 1.05600E-4 | 7.7070E-5 |
| | Er-167 | 7.21320E-5 | 5.2990E-5 |
| | C | N/A | 1.78701E-3 |
| | Hf | N/A | 1.93677E-6 |
| SS304 Cladding | Cr | 1.7385E-2 | 1.7385E-2 |
| | Fe | 5.92090E-2 | 5.92060E-2 |
| | Ni | 7.6995E-3 | 7.6995E-3 |
| | Mn | 1.7320E-3 | 1.7320E-3 |
| Water Coolant | H | 6.6691E-2 | 6.6691E-2 |
| | O-16 | 3.3346E-2 | 3.3346E-2 |

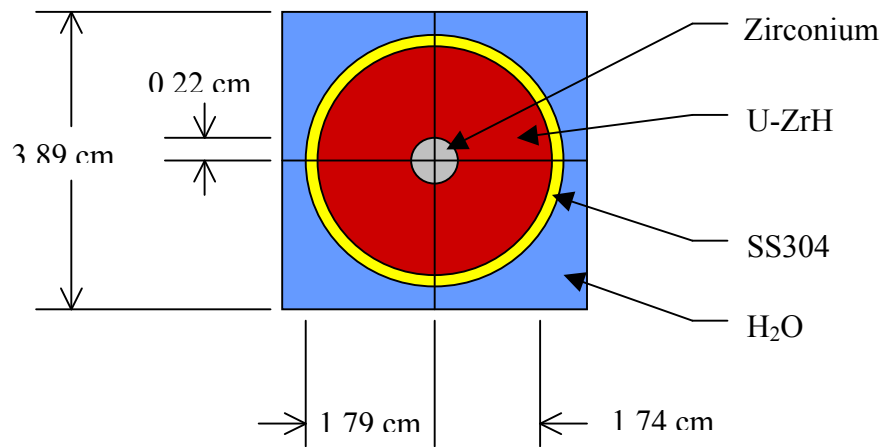

Fig. 6. Radial cross section of NSCR fuel rod

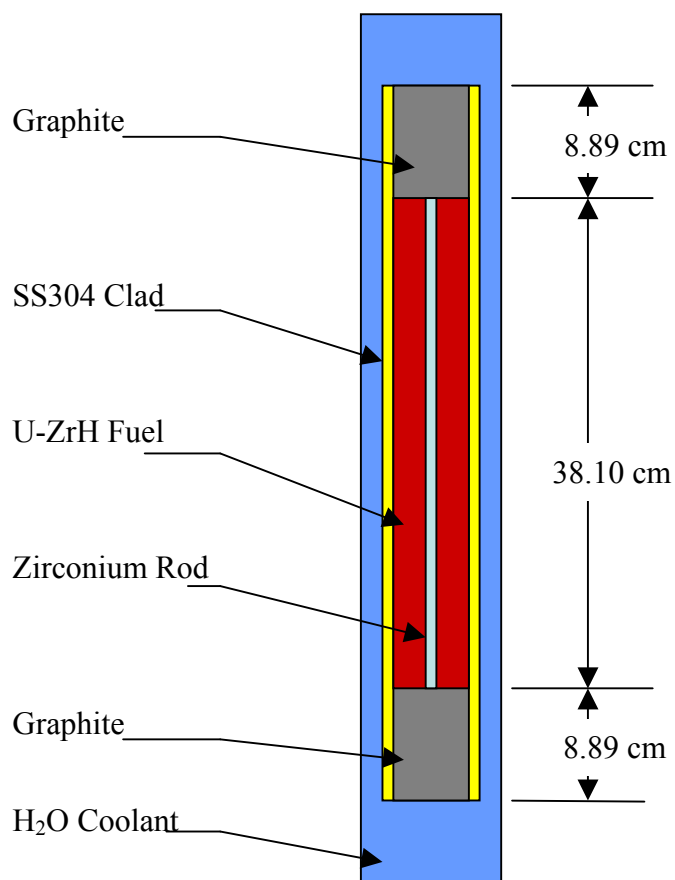

Fig. 7. Axial cross section of NSCR fuel rod

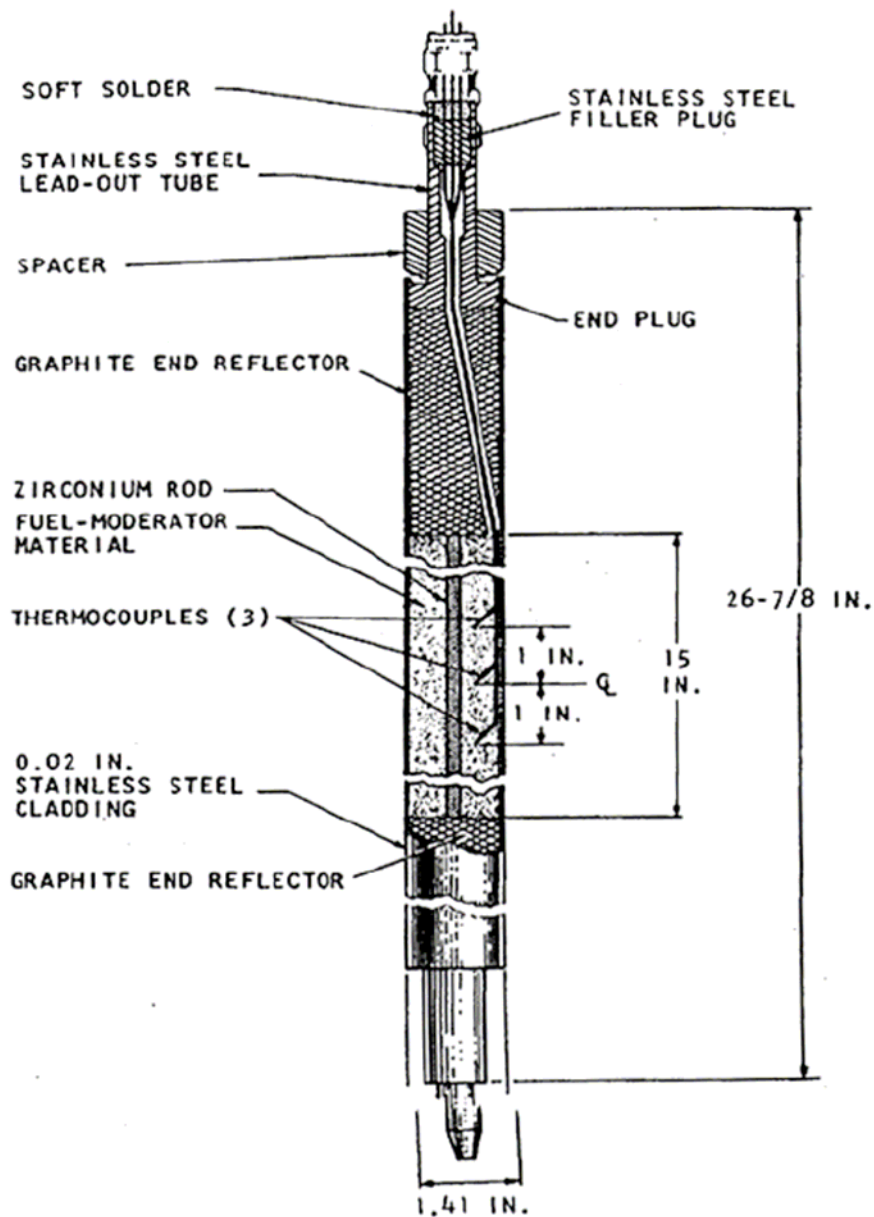

Fig. 8. NSCR fuel rod with thermocouples³

II.D. Control Rod Characteristics

Fuel followed control rods have fuel located below the borated graphite absorber used as the control rod. This control portion of the rod is fourteen inches in length, one

inch short of the full fuel rod length. The Shim Safety rods have an active diameter of 1.7 inches. When fully inserted the Shim Safety rod's borated graphite portion sits one inch from the bottom of the active portion of surrounding fuel rods. Fig. 9 illustrates the cross-sectional view while Fig. 10 illustrates the axial profile of a Shim Safety control rod modeled in MCNP. Table III contains the fresh isotopics of a Shim Safety control rod.

The Regulating and Transient rods are both fifteen inches in length. The Regulating rod has a smaller diameter than the other five control rods at 1.52 inches. The Transient rod sits on top of a twenty inch air gap for the purposes of pulsing; during normal operation the transient rod is fully withdrawn. Fig. 11 illustrates the cross-sectional view while Fig. 12 illustrates the axial profile of the Transient control rod as modeled in MCNP. Table IV contains the fresh isotopics of a Transient control rod. The Regulating rods cross-section is illustrated in Fig. 13 while Fig. 14 illustrates the axial profile of the Regulating control rod as modeled in MCNP. Table V contains the fresh isotopics of the Regulating control rod.

All the Shim Safety rods and the Transient rod have SCRAM capability while the Regulating rod does not.

TABLE III
NSCR Shim Safety Control Rod Material Compositions

| Material | Isotope | 20/30 Fuel Atomic Density (atoms/b- cm) |
|------------------|---------|---|
| Borated Graphite | C | 1.00824E-1 |
| | B-10 | 2.1824E-2 |
| | B-11 | 5.1500E-3 |
| SS304 Cladding | Cr | 1.7385E-2 |
| | Fe | 5.92060E-2 |
| | Ni | 7.6995E-3 |
| | Mn | 1.7320E-3 |
| Water Coolant | H | 6.6691E-2 |
| | O-16 | 3.3346E-2 |

TABLE IV
NSCR Transient Control Rod Material Compositions

| Material | Isotope | 20/30 Fuel Atomic Density (atoms/b- cm) |
|------------------|---------|---|
| Borated Graphite | C | 1.00824E-1 |
| | B-10 | 2.1824E-2 |
| | B-11 | 5.1500E-3 |
| SS304 Cladding | Cr | 1.7385E-2 |
| | Fe | 5.92060E-2 |
| | Ni | 7.6995E-3 |
| | Mn | 1.7320E-3 |
| Water Coolant | H | 6.6691E-2 |
| | O-16 | 3.3346E-2 |

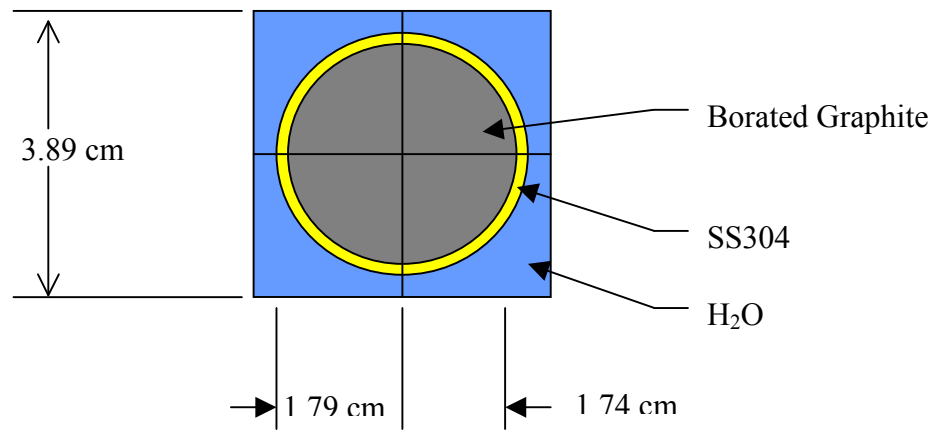

Fig. 9. Radial cross section of NSCR Shim Safety control rod

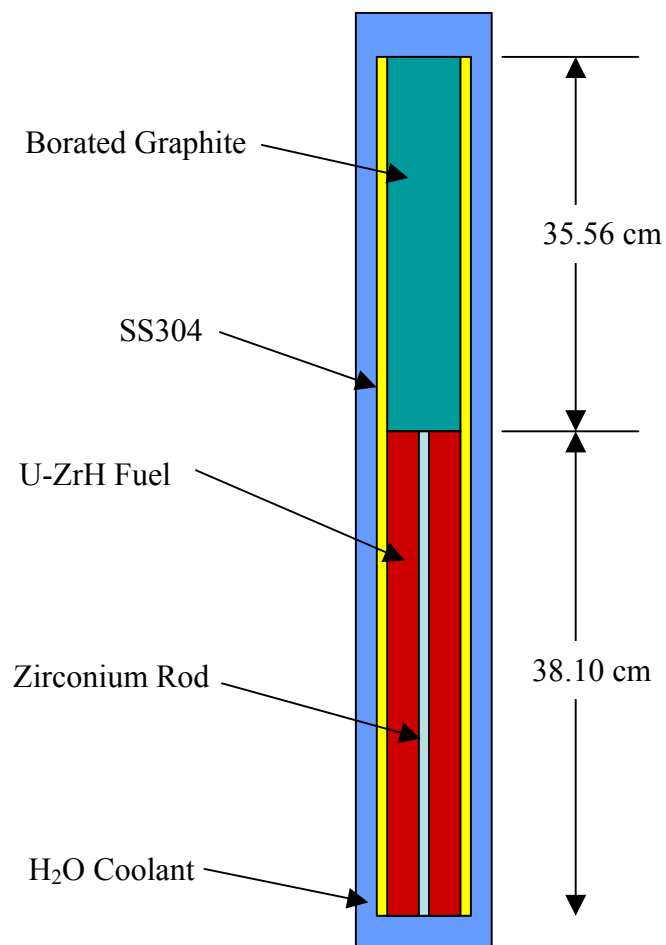

Fig. 10. Axial cross section of NSCR Shim Safety control rod

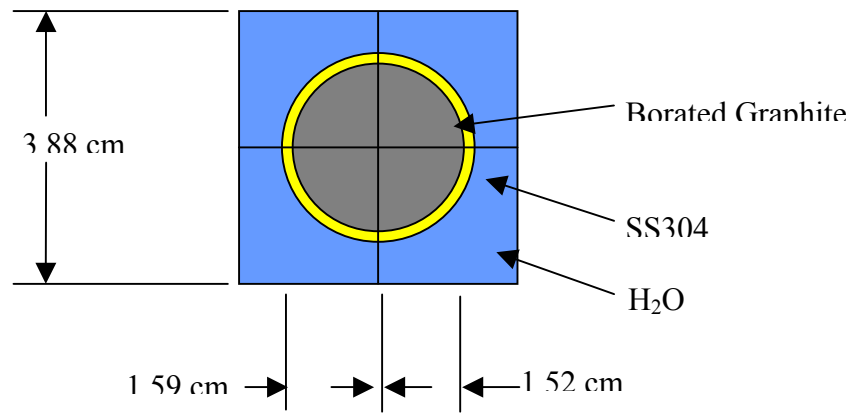

Fig. 11. Axial cross section of NSCR Transient control rod

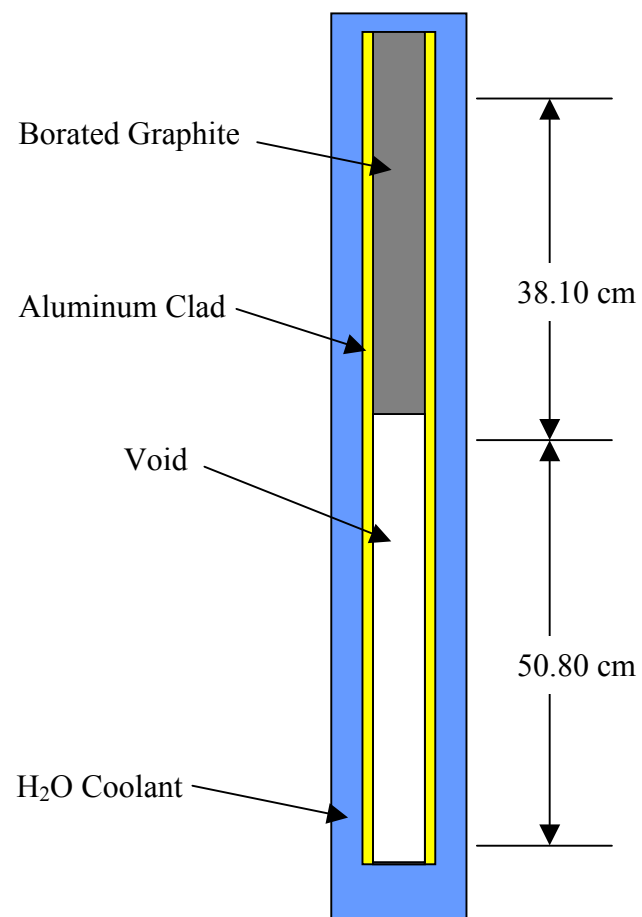

Fig. 12. Axial cross section of NSCR Transient rod

TABLE V
NSCR Regulating Rod Material Compositions

| Material | Isotope | 20/30 Fuel Atomic Density (atoms/b- cm) |
|-------------------------|---------|---|
| B ₄ C Powder | C | 2.7247E-2 |
| | B-10 | 2.0598E-2 |
| | B-11 | 8.7298E-2 |
| SS304 Cladding | Cr | 1.7385E-2 |
| | Fe | 5.92060E-2 |
| | Ni | 7.6995E-3 |
| | Mn | 1.7320E-3 |
| Water Coolant | H | 6.6691E-2 |
| | O-16 | 3.3346E-2 |

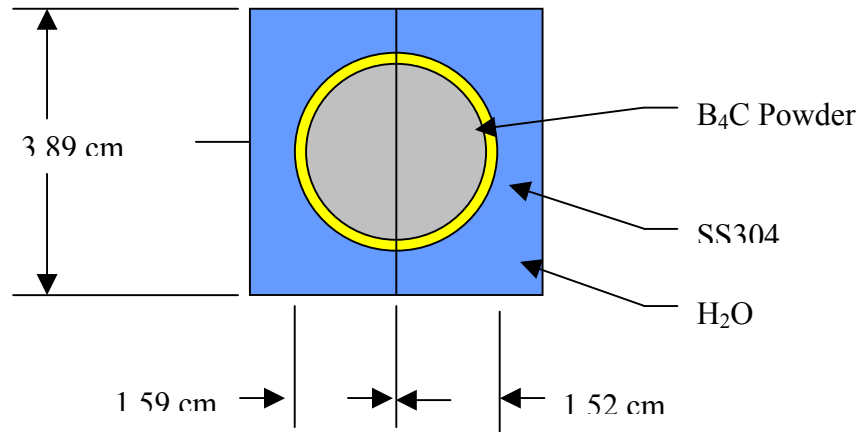

Fig. 13. Radial cross section of NSCR Regulating rod

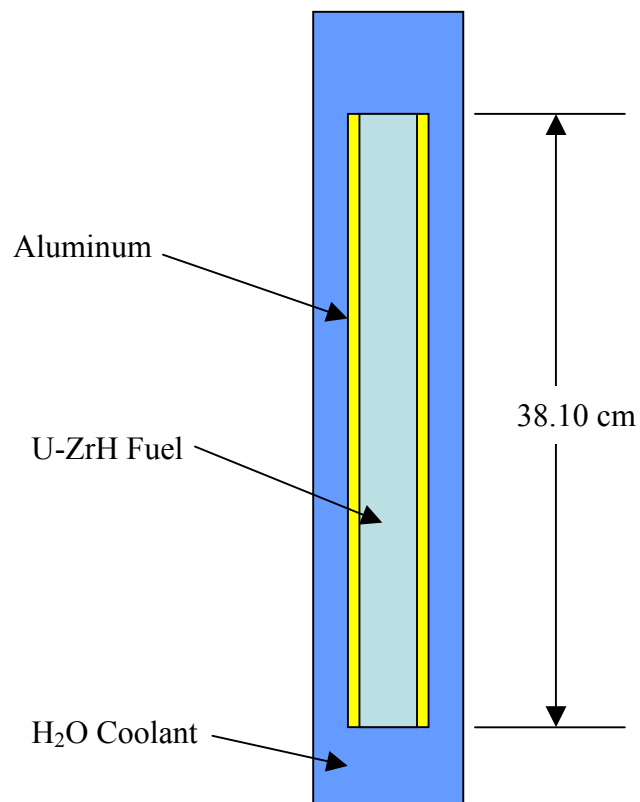

Fig. 14. Axial cross section of NSCR Regulating rod

III. CODE OVERVIEW

A Visual Basic code named NSCRFM (Nuclear Science Center Fuel Management) was written that would track the fuel inventory, calculate flux values in irradiation locations, and predict isotopic inventory of irradiated fuel elements for the NSCR. NSCRFM provides a simple interface for users. This interface allows links to MCNP⁸ to simulate neutron flux distributions in the core and to ORIGEN2⁶ to simulate fuel burnup. NSCRFM updates a fuel isotopics database to track irradiated fuel inventory. NSCRFM would create MCNP input files with minimal user interaction, run MCNP and post process fluxes from MCNP output to create input files for ORIGEN2, run ORIGEN2 to calculate burnup, and then post process the ORIGEN2 output to update the fuel isotopics database. MCNP was used to generate a cross section library for ORIGEN2 based on fresh fuel isotopics, the MCNP runtime to generate cross sections was deemed too long to be recalculated with each code execution.

III.A. NSCRFM Information Flow

Fig. 15 shows how information flows in NSCRFM. The user is presented with a GUI showing the core layout and allowing for fuel movement. The GUI also allows the user to see information from the database about any particular fuel rod including the fuel identification number, burnup, and average flux during the run. When NSCRFM is executed the Visual Basic program gets the current core layout that the database has along with the current fuel isotopics and builds an MCNP deck. This MCNP deck is then executed through shell commands by Visual Basic and returns the average flux for each fuel and control rod in the core. This rod wise flux information is used along with a power log from the operations computer to build an ORIGEN2 deck. A shell command

is then used to execute the ORIGEN2 code for each fuel and control rod. ORIGEN2 returns updated fuel isotopics information for each of these rods. The Visual Basic code then takes that isotopic information from each ORIGEN2 output file and updates the Microsoft Access database with each rod. At the completion of the last database update, the Visual Basic code informs the user it has completed its run and is ready for the next day's operation.

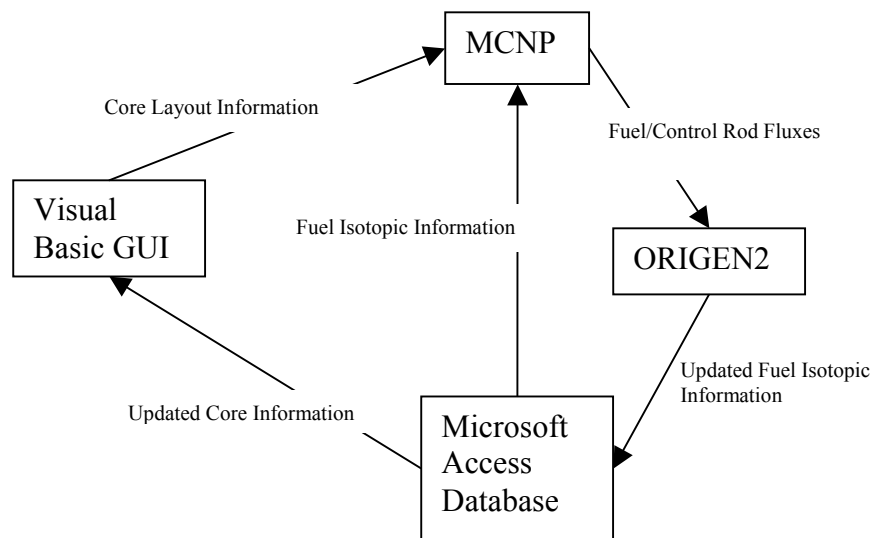

Fig. 15. Flow chart for NSCRFM

III.B. NSCRFM Details

This code employs a Visual Basic graphic user interface (GUI) that links MCNP, ORIGEN2 and Microsoft Access together. It presents a graphical layout of the core for the user to locate fuel rods and move rods if necessary. Much of the Visual Basic code involves dealing with the Microsoft Access database interface.

A Visual Basic form was created to provide the user with a graphical layout of the core and the storage area in the NSCR. This form is displayed in Fig. 16.

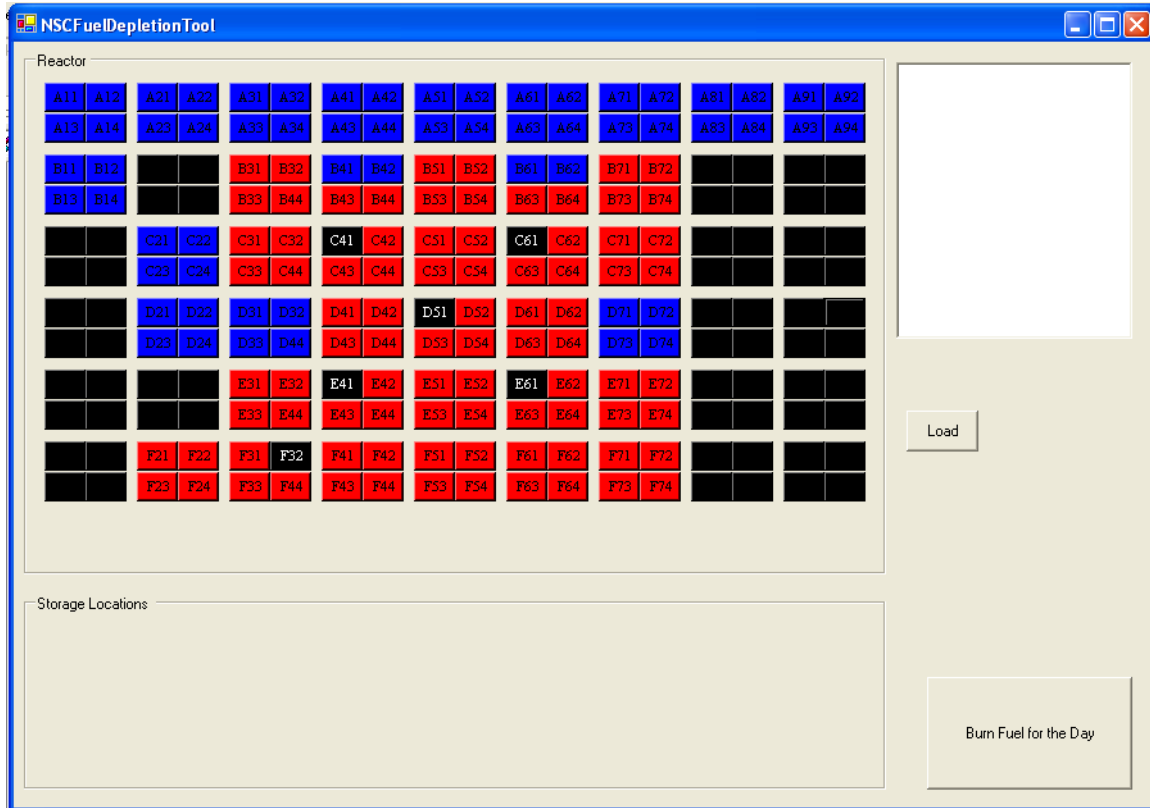

Fig. 16. Main form for NSCRFM

On this form are the core layout and a text box on the right hand side, which provides information on the particular core location that the user has selected. This text box contains information like the fuel identification number, the burnup, and current location in the core for any selected core location. The button in the lower right hand corner labeled “Burn Fuel for the Day” is used to execute the simulation when the user has completed any preliminary tasks.

The core locations in the layout in Fig. 16 are colored based on what material is located in that position. The Visual Basic code fills the core based on the current database. NSCRFM checks a field in the main table displaying what kind of material is

currently in that core location and associates with a particular color: red for fuel, blue for water, black without core location identifier for graphic blocks, and black with core location identifier for control rods. When the user is ready to execute the code, they press the “Burn Fuel for the Day” button in the lower right hand corner of the form. This begins the process laid out earlier in this section.

III.B.1. Interfacing with MCNP

A skeleton MCNP deck is stored on the machine that keeps information for the cell cards, and surface cards. A lattice card is created by NSCRFM from the current database information. It does this by searching the database for all core locations containing the letter A then B then C and so on until F which is the last core row. Within each row the code finds what is in each core location and places the corresponding MCNP identification number into a text file to be merged with the MCNP skeleton deck. After the lattice is complete, the code moves on to create the materials card for MCNP. It does so by going through the database and for every fuel and control rod in the core NSCRFM links to the corresponding fuel information table and copies it into a text file to be merged into the MCNP skeleton deck after all the materials for the core have been added to the deck.

After the MCNP deck has been created, the Visual Basic code runs MCNP with a shell command and monitors the job for completion. Upon completion of the MCNP deck execution, NSCRFM opens the output file and begins to extract the average flux for each fuel and control rod calculated by MCNP. It does this by starting at the top of the database and one by one searching the MCNP output file for that fuel or control rod,

when the search finds a match NSCRFM copies the average flux into a field on the Fuel Information table for that corresponding rod.

Flux tallies are taken by MCNP in the form of an f4 tally, which is a track length estimate within an MCNP cell, namely the fuel rod. The average flux over the cell is calculated by MCNP by summing the track lengths of all particles in the cell¹⁰.

III.B.2. Interfacing with ORIGEN2

Following data extraction from the MCNP output file, NSCRFM builds the ORIGEN2 deck. A skeleton deck was built that contains constants for every run including which cross section libraries to use and other information that does not change during every run. NSCRFM extracts the daily power log from the operations computer. The power log is a text file containing a minute-by-minute list of the percent power the reactor was operating at for that twenty four hour time period. The MCNP neutron flux tallies (f4 tallies) are output in units inverse cm² per source particle, NSCRFM converts this value to properly normalized units of flux. The MCNP value is multiplied by the number of neutrons per second being produced from fission when the reactor is operating at 1MW, or:

$$\frac{1MW}{1.602176E-13J} \cdot \frac{1MeV}{200MeV} \cdot \frac{1 \text{ Fission}}{1 \text{ Fission}} \cdot \frac{2.43neutrons}{1 \text{ Fission}} = 7.5834E16 \frac{\text{neutrons}}{\text{sec}}$$

The information from the power log is averaged into ten minute blocks, multiplied by this corrected flux value from MCNP, and then combined with the ORIGEN2 skeleton deck for each rod. From the database, the materials are extracted into the format required by ORIGEN2, this required that the materials be split into three categories: actinides, activation products, and fission products. All the materials stored to a particular rod are loaded into the ORIGEN2 input file by combining the materials identifier with the

amount stored in the database. Since MCNP and ORIGEN2 require unique numerical identifiers for all materials these numbers were stored as an array in NSCRFM.

ORIGEN2 can only burn one rod at a time so NSCRFM goes through the database and creates and runs an input file for each rod in the database. Upon completion of each ORIGEN2 run, the Visual Basic code extracts the burned materials from the output file and writes over the saved data in the database. After all the rods have been burned, NSCRFM is complete and reports back to the user that it has updated the database.

IV. CODE DETAILS

IV.A. MCNP

The MCNP deck needs to be very detailed to simulate the NSCR and achieve meaningful results. Because this is a research reactor many assumptions are valid that will not be in a production reactor. This occurs because the power in research reactors is typically lower, in this case 1MW; with the temperature of the coolant being only slightly above ambient. The use of a solid Zr-H moderator makes the mean free path of neutrons in the core longer than in production reactors. Neutrons lose less energy on average for collisions with a Zr-H molecule than a H₂O molecule making the mean free path longer.

A simulation was run to test whether or not the fuel rods could be treated as a single radial region. A single pin identical to a NSCR fuel rod was modeled in an infinite lattice of itself with a varying number of radial regions, as seen in Fig. 17.

This model was run with 1, 2, 4, 6, and 8 radial fuel regions. This model was used to obtain a neutron flux profile across the fuel regions. This MCNP model was also used in a MonteBurns⁷ model to track what effect the number of regions would have on the uranium content of the fuel, more specifically the depletion of uranium in the fuel. As can be seen from the data the number of fuel regions affects neither the flux across a fuel rod, Table VI and Fig. 18, or the depletion of uranium, Table VII, significantly. In Table VI the flux tally is normalized to its maximum value, as one can see the value varies little from unity. Fig. 18 is a plot of this table, helping to illustrate that the assumption of a single fuel region approximating the fuel rod was acceptable.

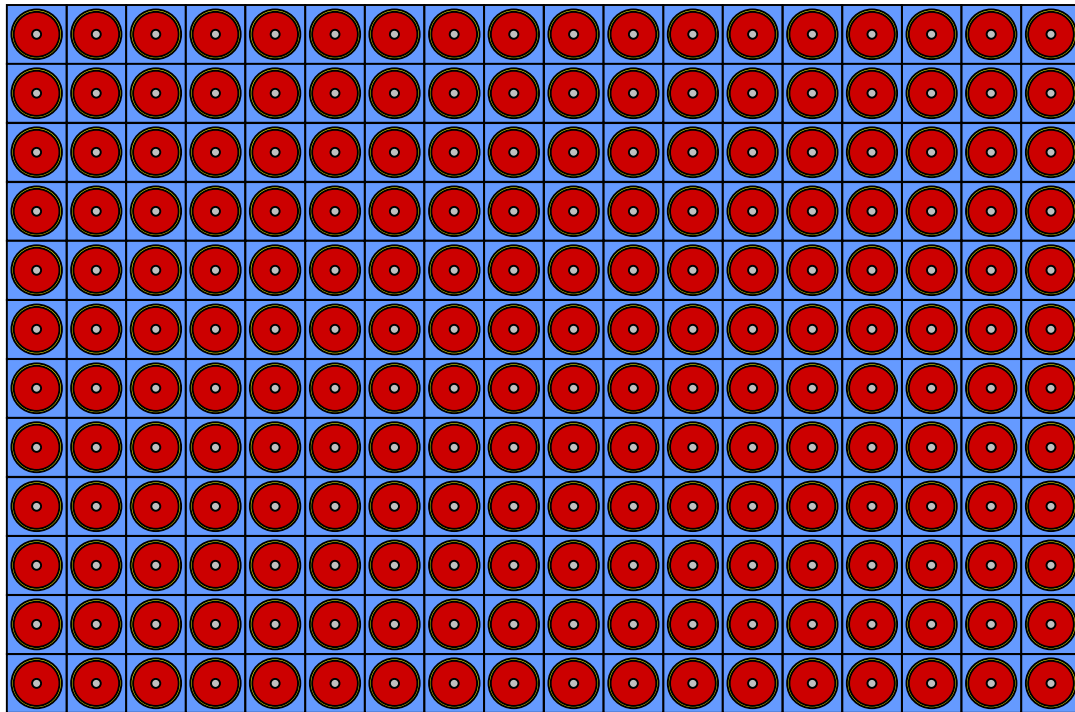

Fig. 17. Infinite lattice of NSCR fuel rod

TABLE VI
Normalized 1-Group Flux for 8 Region NSCR fuel rod

| Outside Radius | Normalized Neutron Flux |
|-------------------|----------------------------|
| 0.228 | 1.00E+00 |
| 0.4171375 | 9.82E-01 |
| 0.606275 | 9.80E-01 |
| 0.7954125 | 9.84E-01 |
| 0.98455 | 9.85E-01 |
| 1.17369 | 9.87E-01 |
| 1.55196 | 9.92E-01 |
| 1.7411 | 9.94E-01 |

Shown in Table VII are the grams of select isotopes pertinent to this project versus the number of radial fuel regions in the model. These data are from the Monteburns burnup code, the totals are based on a 1MT fuel load and are burned to 365 MWD/MT. As can be seen in these data as well, the number of fuel regions has little impact on the accuracy of the model.

TABLE VII
Grams of Select Isotopes in NSCR Fuel Rod after 1500 Days versus the Number of Radial Fuel Regions

| Number of Fuel Radial Regions | U-235 | U-238 | Pu-239 | Pu-240 |
|-------------------------------|----------|----------|----------|----------|
| 1 | 9.93E+01 | 5.23E+01 | 6.85E-01 | 5.06E-02 |
| 2 | 9.93E+01 | 5.23E+01 | 6.85E-01 | 5.06E-02 |
| 4 | 9.93E+01 | 5.23E+01 | 6.85E-01 | 5.06E-02 |
| 6 | 9.93E+01 | 5.23E+01 | 6.85E-01 | 5.06E-02 |
| 8 | 9.93E+01 | 5.23E+01 | 6.85E-01 | 5.06E-02 |

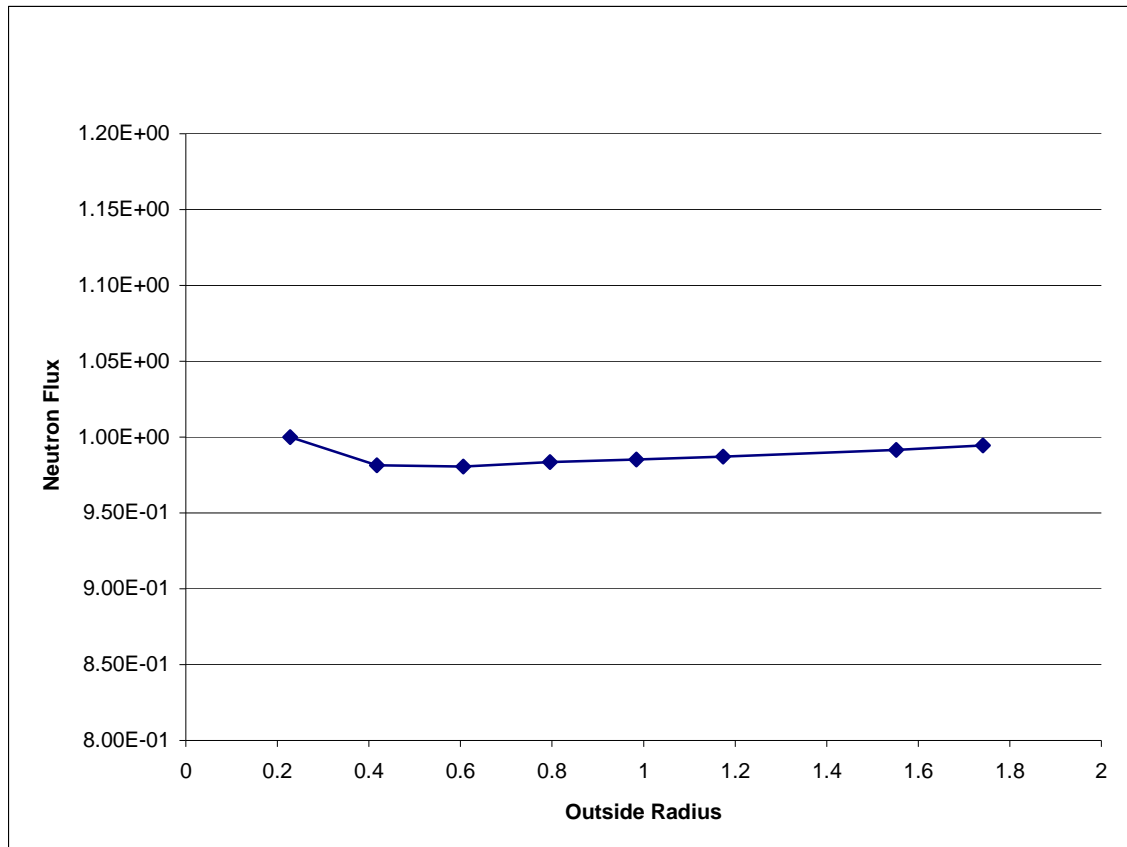

Fig. 18. Normalized neutron flux for 8 region NSCR fuel rod

To build a complex structure like the NSCR core, MCNP includes a lattice creation card. To define a lattice one needs the bounds of the structure and to define universes that will fill the structure. For this MCNP lattice the universes were defined for each fuel and control rod, while others define water channels or a graphite blocks. Now the lattice can be defined as a matrix of these universe numbers. Fig. 19 illustrates an example lattice card for this reactor. Here these numbers represent the universes defined in the deck; this lattice describes for MCNP the diagram of the NSCR given in Fig. 5. The first line of this lattice card tells MCNP which planes makeup the outer bounds of the elements within the lattice universe. While the “fill” command tells MCNP to place 17 elements from left to right and 11 elements from top to bottom. All of these definitions

are for only the x and y planes. The universes for the lattice elements define the vertical dimension of that universe. The last line defines the x and y outer bounds of the lattice universe itself.

```

c          -Reactor Lattice-
1700  0   -702 701 -704 703 lat=1 u=8 fill=0:17 0:11 0:0
6 6  6  6  6  6  6  6  6  6  6  6  6 6 6 6 6
6 6  6  6  6  6  6  6  6  6  6  6  6 6 6 6 6
6 6  5  5 113 114  6  6 124 120  6  6 125 126 5 5 5 5
6 6  5  5 115 116 117 118 121 122 123 119 127 128 5 5 5 5
5 5  6  6 132 133 201 136 139 140 202 143 146 147 5 5 5 5
5 5  6  6 108 130 137 138 141 142 144 145 148 149 5 5 5 5
5 5  6  6  6  6 150 151  3 154 157 158  6  6 5 5 5 5
5 5  6  6  6  6 152 153 155 156 159 160  6  6 5 5 5 5
5 5  5  5 161 162 203 165 169 170 204 173 176 178 5 5 5 5
5 5  5  5 163 164 167 168 171 172 174 175 179 180 5 5 5 5
5 5 134 181 184  4 135 111 103 104 107 110 129 131 5 5 5 5
5 5 182 183 185 186 101 102 105 106 112 109 166 177 5 5 5 5 imp:n=1 vol=1
1800  0    +800 -801 +802 -803 fill=8  imp:n=1 vol=1

```

Fig. 19. Lattice structure for NSCR

To be able to track all ninety-two fuel rods and six control rods, two being fuel followed, this MCNP deck has each fuel and control rod as its own universe and has its own material card. As described earlier this deck also contains the thermal column, a large graphite parallelepiped 1” from the west face of the core. For the NSCR the thermal column is defined as “against the core” when it is 1” from the west face. Table VII illustrates the effect the thermal column has on the reactor k-eigenvalue. An MCNP deck was made with critical control positions based on the thermal column being against the core. The thermal column was then moved incrementally away from the core recalculating the eigenvalue each time.

TABLE VIII
Reactivity of Thermal Column

| Distance from Reactor Face | k_{eff} | | $\Delta k/k$ | |
|----------------------------|------------------|---------|--------------|----------|
| 2cm | 1.00056 ± | 0.00022 | | |
| 4cm | 0.99324 ± | 0.00022 | -0.00737 ± | 0.000313 |
| 6cm | 0.98973 ± | 0.00022 | -0.01094 ± | 0.000314 |
| 8cm | 0.988 ± | 0.00022 | -0.01271 ± | 0.000315 |
| 10cm | 0.98759 ± | 0.00023 | -0.01313 ± | 0.000322 |

It was originally intended for the MCNP deck to provide not only updated fluxes for each fuel rod, but also cross sections. MCNP calculates the flux in an f4 tally⁸ as the summation of particle track lengths in a particular cell. MCNP tally multipliers are used to calculate any quantity of the following form:

$$C \int \varphi(E) R_m(E) dE \quad (9)$$

where $\varphi(E)$ is the energy-dependant fluence in units of particles/cm² and $R_m(E)$ is an operator of either additive or multiplicative response functions from the MCNP cross section library. In equation (9) C is an arbitrary scalar quantity. The response function is in relation to the material for which the multiplier card is applied. Using this multiplier card with the response function associated with the cross section to be calculated and the C constant set to unity a reaction rate density for a particular reaction of interest can be calculated. A reaction rate density is defined by:

$$\text{Reaction Rate} = \sum_m \varphi. \quad (10)$$

where the Σ_m is the macroscopic cross section for a particular reaction of material m , and φ is again the fluence. Since MCNP f4 tallies provide the flux, if one takes the reaction

rate calculated with the tally multiplier card and divide by the flux for the cell of interest, then one could attain the macroscopic cross section for any reaction MCNP tracks.

An MCNP deck was made containing all the f4 tallies and multiplier cards for all the isotopes in Table IX with fuel, cladding and solid moderator temperatures at normal operating temperatures (600K) and coolant at ambient temperature (300K). The following reaction rates were calculated for each isotope:

- (n, 2n),
- (n, 3n),
- total fission,
- (n, γ),
- (n, p),
- (n, α).

TABLE IX
Nuclides Included in Reaction Rate MCNP Calculation

| | |
|-------------------|-------------------|
| ^{235}U | ^{239}Pu |
| ^{238}U | ^{240}Pu |
| ^{149}Sm | ^{148}Nd |
| ^{166}Er | ^{135}Xe |
| ^{167}Er | ^{137}Cs |

A previous version of this MCNP deck had been used to calculate the fluxes in each core location, only the tally multiplier cards were added to this deck. The statistical error for these tally multipliers cards increased orders of magnitude above the flux statistical error. To achieve values for the reaction rates that would allow the calculation

of cross section values with less than ten percent statistical error required this simulation to run for approximately 48 hours. This was determined to be too long for the application of the final code package. A single deck was created and run until the statistical errors were well within ten percent. The values for the cross sections calculated from this simulation were used in the daily operation of the final code package. Thus the cross-section sets remain static in the final code package. However, since this MCNP deck exists, if needed the material cards for all fuel/control rods could be updated and the simulation could be run again to calculate updated cross section anytime the user chooses. But for the purposes of the daily operation of NSCRFM package, the cross section sets will remain static.

IV.B. ORIGEN2

A skeleton ORIGEN2 deck was built that contains cross section library information as well as other basic commands for ORIGEN2. A constant flux irradiation was used here. The flux value were inputted from the MCNP output but modified to the correct power level based on the power log for the previous day. This constant flux irradiation section of the ORIGEN2 input deck was built by a Visual Basic subroutine and stored in a text file. Another subroutine retrieves the material information from the database and puts it into an ORIGEN2 input file. A batch file then concatenates the skeleton deck and the irradiation information into an ORIGEN2 input file.

The standard ORIGEN2 cross section libraries model many reactor types such as PWR, BWR, and CANDU reactors but, TRIGA reactor libraries were not included. A code called Monteburns⁷ was used to generate a cross section set for the TRIGA reactor that ORIGEN2 could read.

Los Alamos National Laboratory produces and maintains Monteburns. It is a code package that links MCNP and ORIGEN2 to simulate reactor operation and predict fuel burnup⁷. Monteburns uses a user defined number of steps to complete the irradiation process, the user defines how many MCNP steps and then how many ORIGEN2 steps to run, generally two ORIGEN2 steps are required per MCNP set but more can be run. The Monteburns code uses a basic ORIGEN2 cross section library and modifies it as it executes, these cross section sets get updated after each MCNP step. Producing at the end of execution several cross section sets used by ORIGEN2 to simulate the irradiation of fuel.

A Monteburns deck was built containing an MCNP deck that models the NSCR system and an input file telling Monteburns information such as which MCNP material contains the material of interest, which isotopes to track during operation, how long to run the simulation, and a power history. The simulation tracked all the isotopes contained in Table VII.

After each outer iteration in Monteburns, the cross sections were updated based on flux and reaction rate tallies from MCNP. This Monteburns run used an outer iteration time step of 73 days. Monteburns generated cross section sets (labeled MONT1 – MONT5) along with other cross section sets internal to ORIGEN2 were then used to burn the fuel in ORIGEN2 for the same duration as the full Monteburns run. Figs. 20-30 illustrate how the cross section set performed. Included in each of these plots are the Monteburns generated cross section sets (labeled MONT1 – MONT5), the basic ORIGEN2 cross section set that best fits the Monteburns data (labeled PWR3D35), and the fifth Monteburns run (labeled MONTEBURNS). As a result Figs 20 - 30 show the

mass of each isotope at intervals of 73 days. As one can see all the Monteburns cross section sets trend well with the full Monteburns run. While the standard ORIGEN2 cross section set trends with some isotopes, such as both uranium isotopes, but performs poorly with others, such as ^{239}Pu .

The difference between the Monteburns generated cross sections sets was shown here to be minimal and thus the first set (MONT1) was taken and used with ORIGEN2 as the TRIGA cross section set for the purposes of the NSCRFM code.

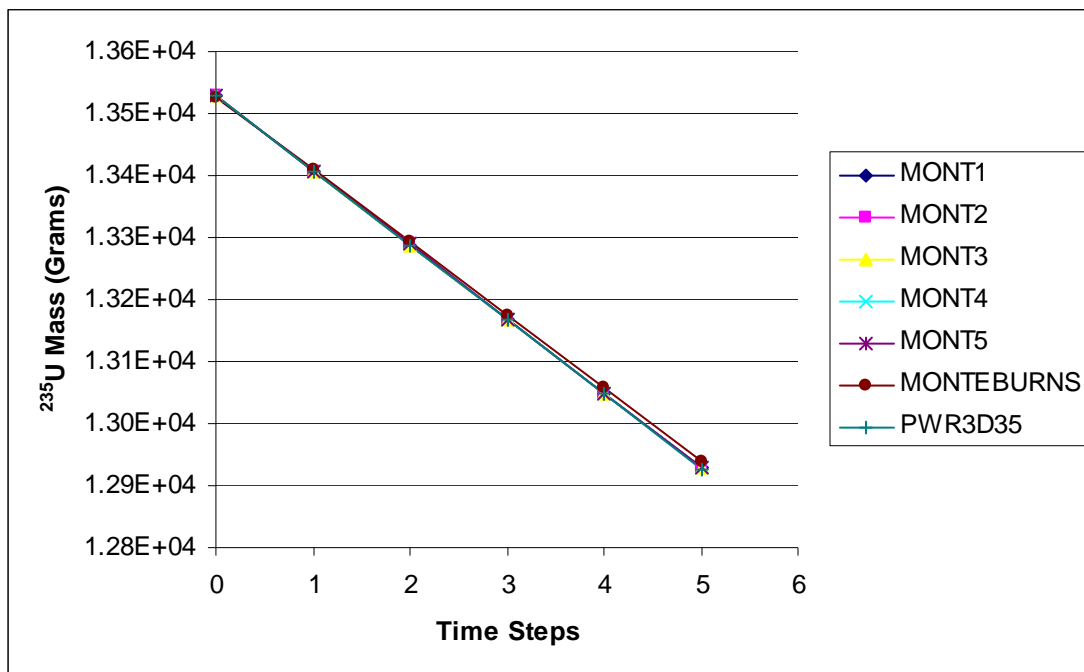

Fig. 20. Comparison of Monteburns generated ORIGEN2 cross sections sets for ^{235}U

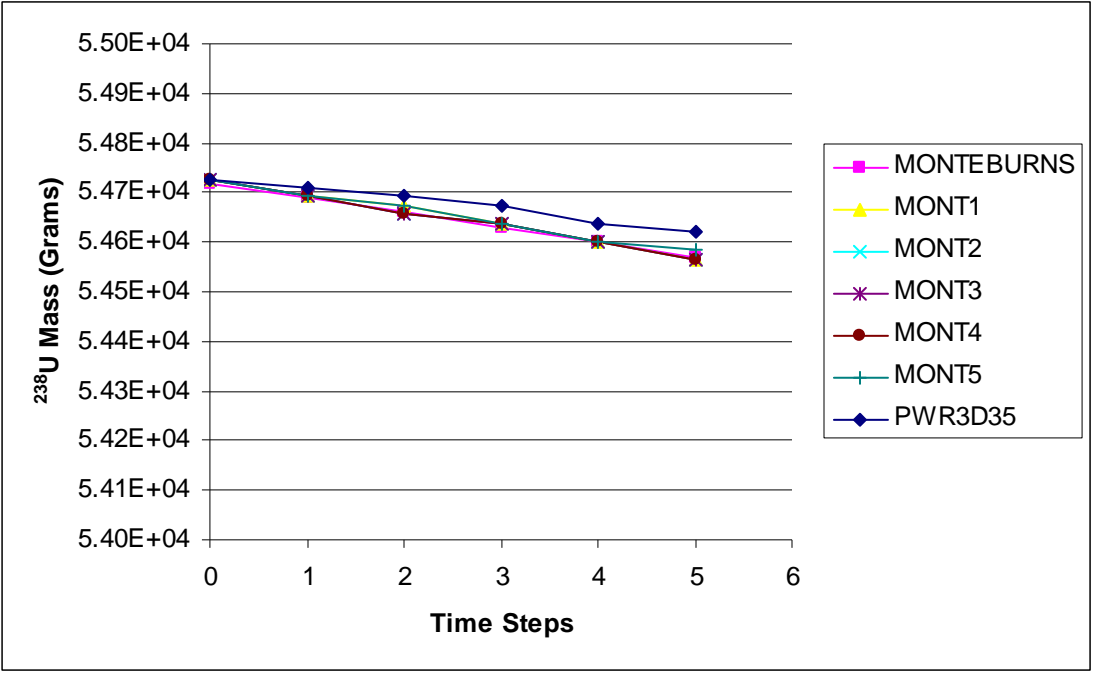

Fig. 21. Comparison of MonteBurns generated ORIGEN2 cross sections sets for ²³⁸U

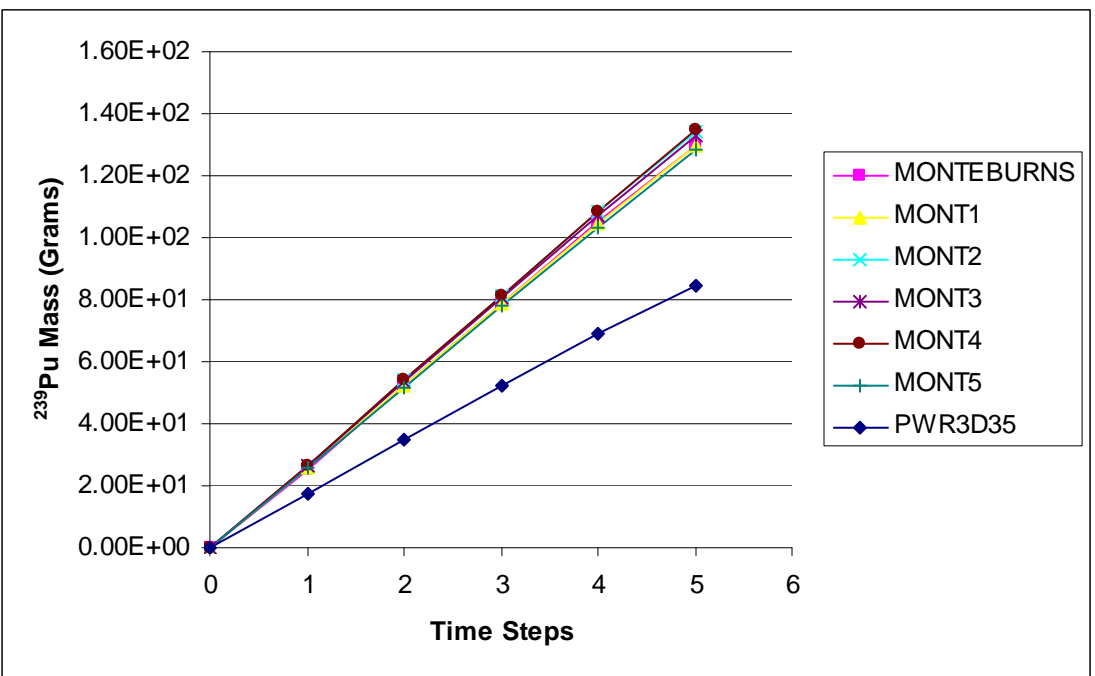

Fig. 22. Comparison of MonteBurns generated ORIGEN2 cross sections sets for ²³⁹Pu

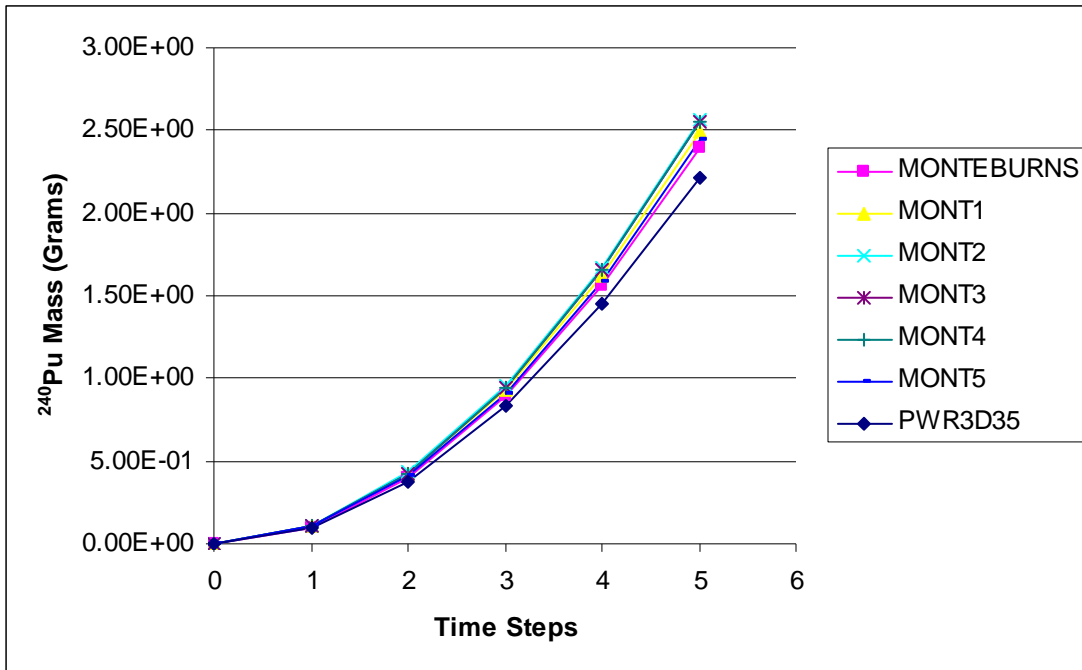

Fig. 23. Comparison of MonteBurns generated ORIGEN2 cross sections sets for ^{240}Pu

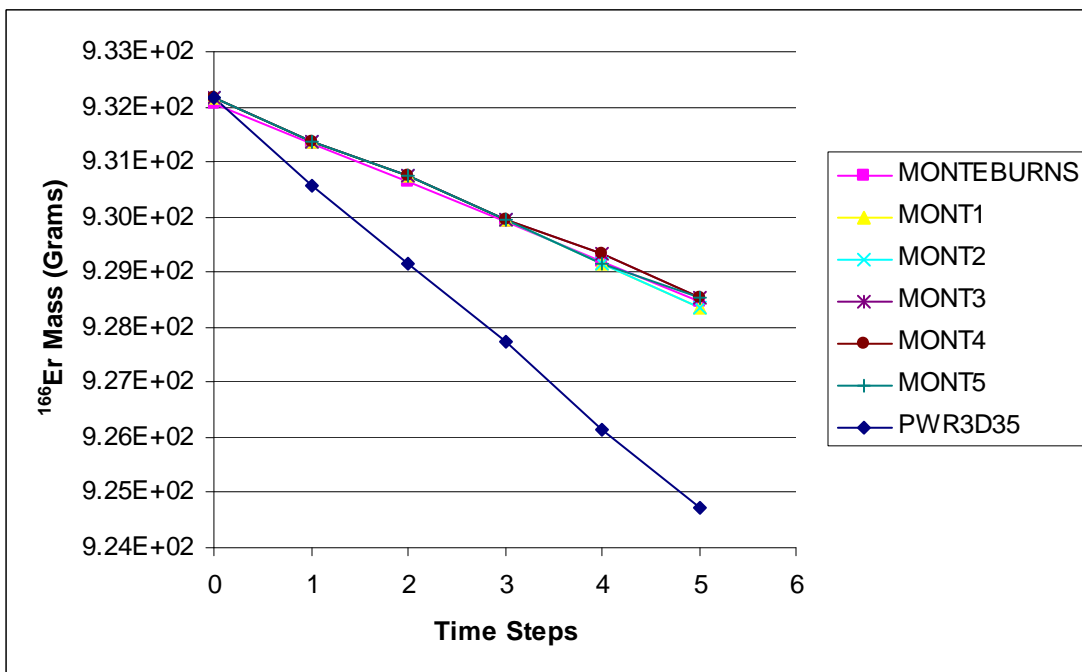

Fig. 24. Comparison of MonteBurns generated ORIGEN2 cross sections sets for ^{166}Er

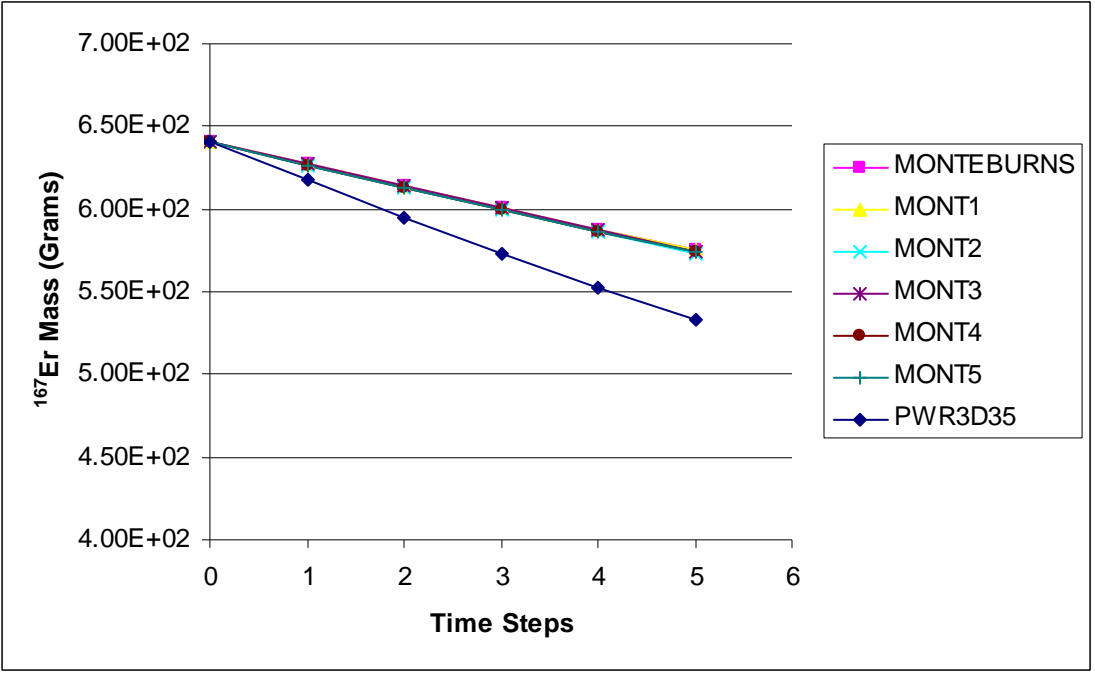

Fig. 25. Comparison of MonteBurns generated ORIGEN2 cross sections sets for ¹⁶⁷Er

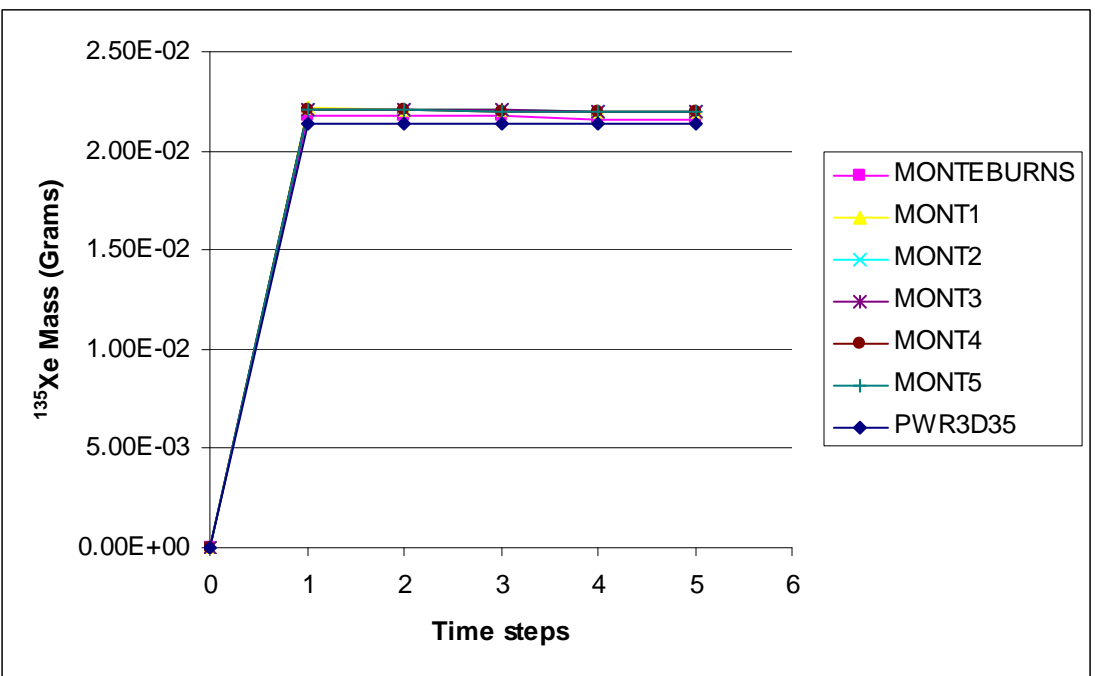

Fig. 26. Comparison of MonteBurns generated ORIGEN2 cross sections sets for ¹³⁵Xe

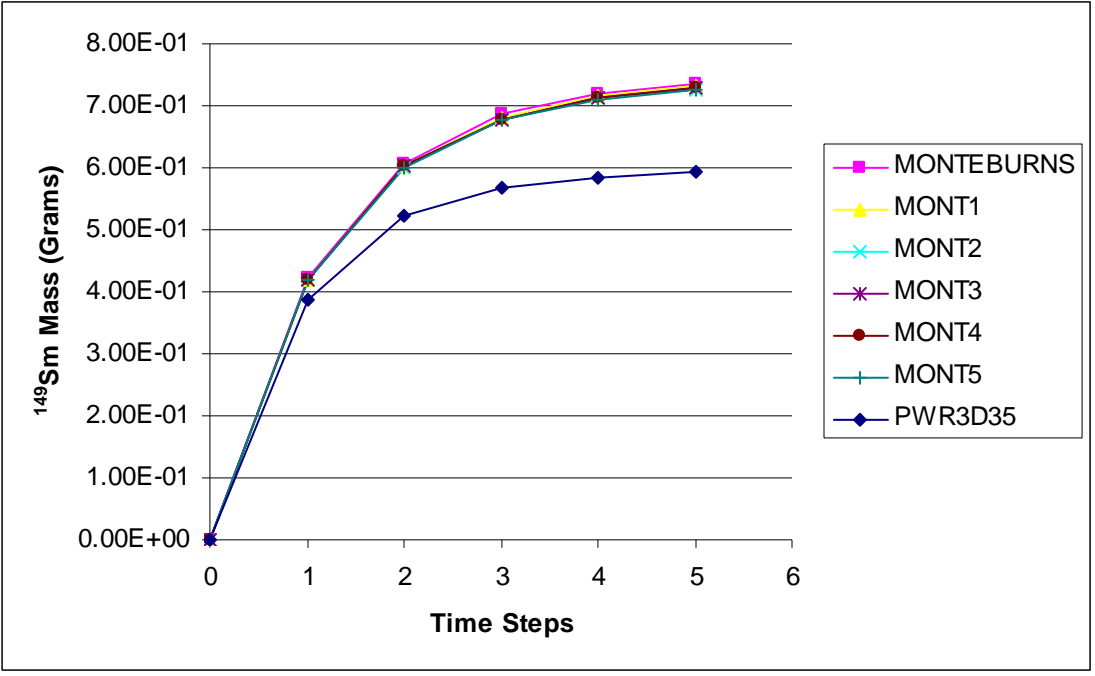

Fig. 27. Comparison of Monteburns generated ORIGEN2 cross sections sets for ¹⁴⁹Sm

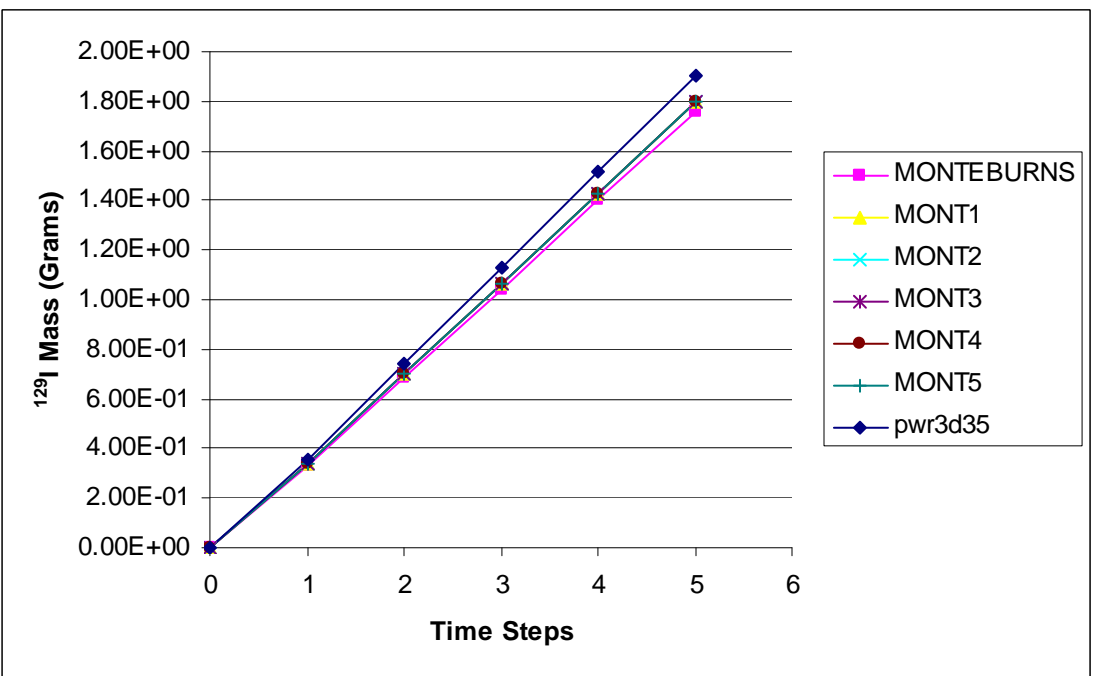

Fig. 28. Comparison of Monteburns generated ORIGEN2 cross sections sets for ¹²⁹I

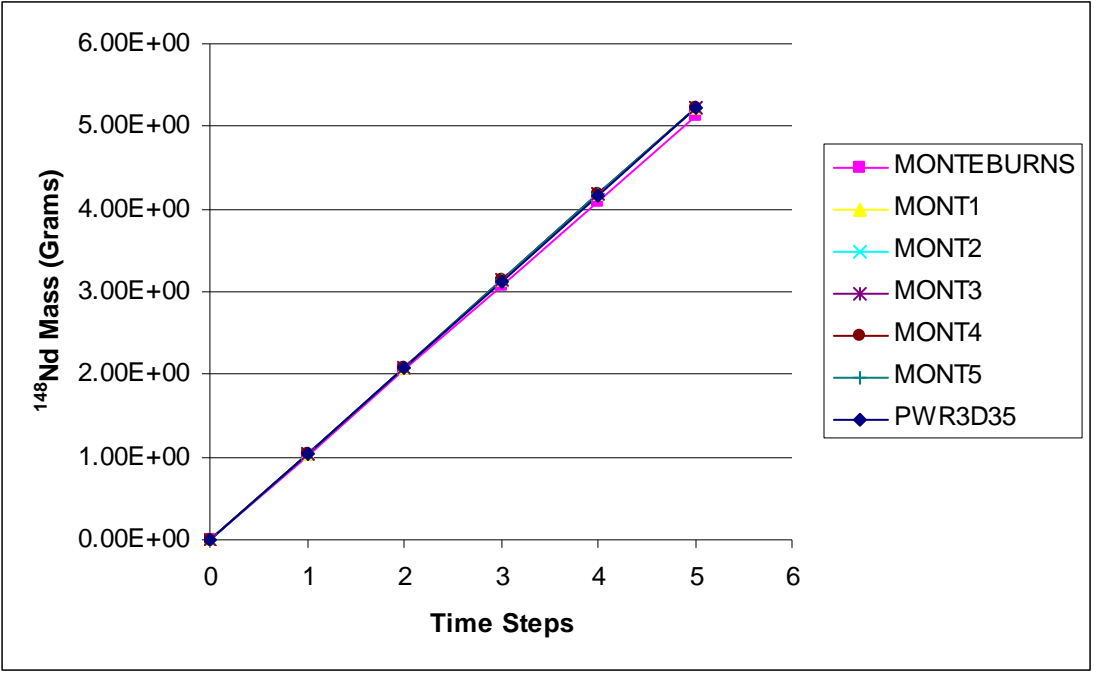

Fig. 29. Comparison of MonteBurns generated ORIGEN2 cross sections sets for ¹⁴⁸Nd

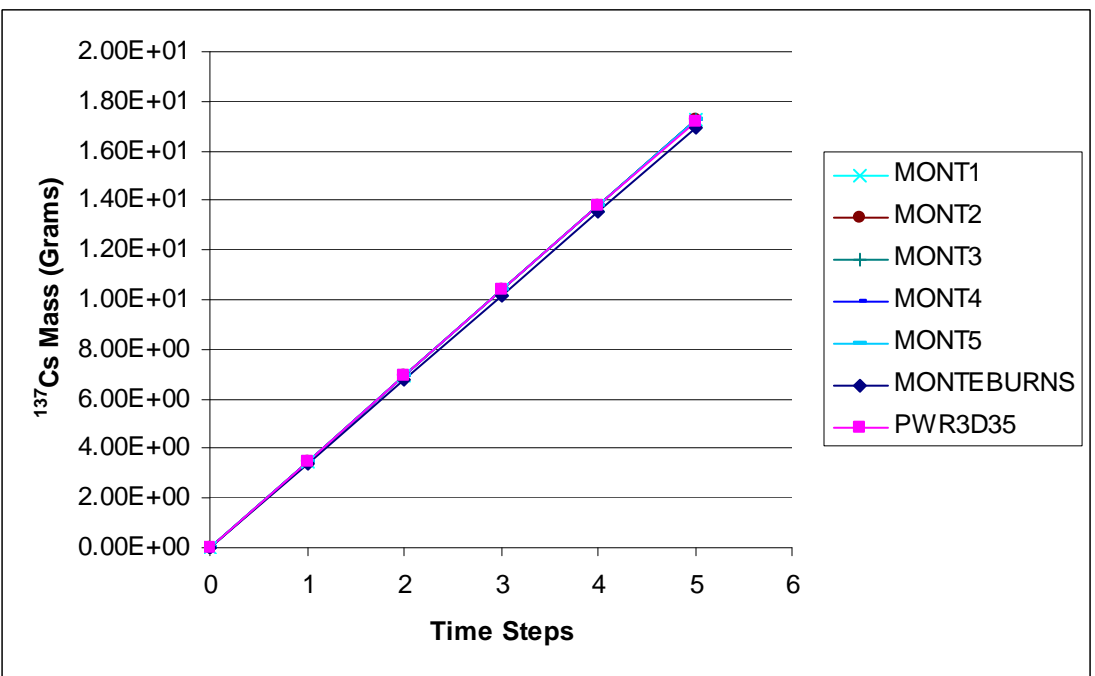

Fig. 30. Comparison of MonteBurns generated ORIGEN2 cross sections sets for ¹³⁷Cs

IV.C. Visual Basic

Visual Basic was used here to create a graphic interface and for processing the input and output files of MCNP and ORIGEN2. Both of these codes produce large output files. So text file pre-and post-processing subroutines were created using Visual Basic. These subroutines create the parts of the MCNP and ORIGEN2 decks that change during every run. The subroutines also process the output files to extract what NSCRFM needs to continue execution while condensing some information for a more manageable retrieval later if needed.

The main form that the user sees when NSCRFM is started up is in Fig. 31. From here the user could move fuel rods or begin the burn cycle for the day. When a core location is selected the window on the left of the main form receives data from the database telling the user what was in the selected core location and what could be placed in that location. This form is shown in Fig. 32.

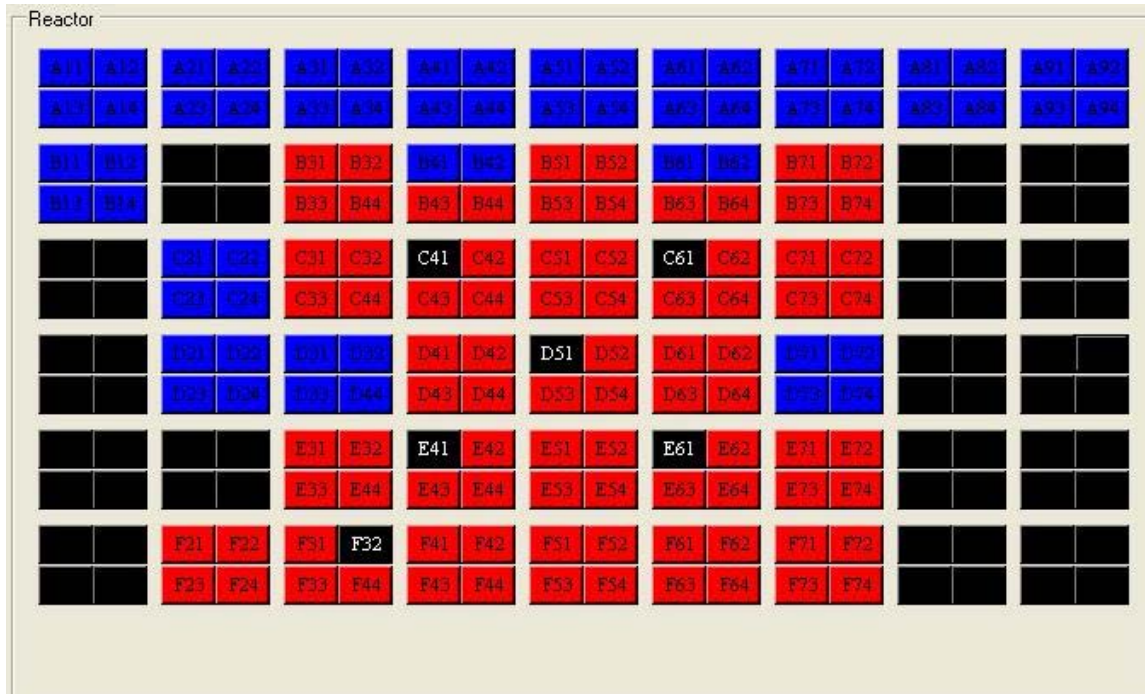

Fig. 31. Main form for NSCRFM

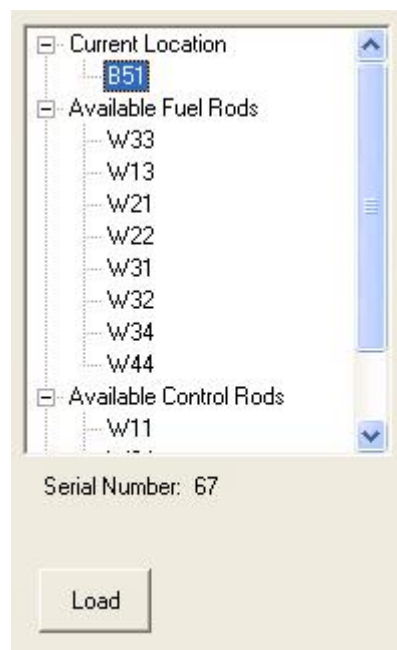

Fig. 32. Window for moving fuel

To prevent the user from accidentally moving rods around within the core, whenever the “Load” button is pressed a message box will pop up asking the user to confirm the move. This message box is shown in Fig. 33. Whenever the user has completed any preliminary operations to the layout of the core they may push the button, Fig. 34, in the lower right corner to begin code execution.

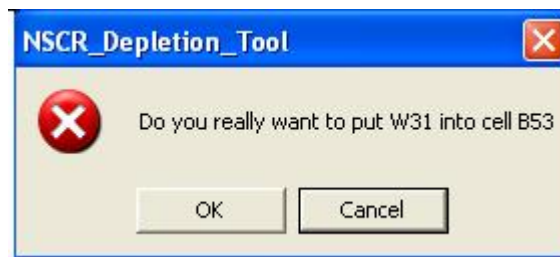

Fig. 33. Message box prompting the user to confirm fuel movement

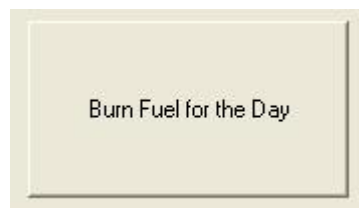

Fig. 34. Button for burnup code execution

The MCNP input file contains five sections: the cell cards, the lattice structure, surface definitions for the cells, material cards, and the tally card. The surface cards define the location of basic planes and 3-dimensional shapes that make up the cells defined in the cell cards. Neither of these sections changes in between code runs. In other words, all the fuel, control rods, graphite blocks, and water holes are the same shape in every run. However, the lattice structure can change to move rods around within the core or replace them with graphite or water. The material cards change every run to

keep track of the changing isotopic makeup of the fuel rods. The tally cards change to reflect any change in the lattice structure. When creation of these files is complete the visual basic code takes over and concatenates them together into the MCNP input file.

The execution of MCNP was done by a shell command. MCNP was run within a DOS command window opened by this shell command. Visual Basic contains events that can be executed when a particular event occurs within NSCRFM. For this system, the Visual Basic code watches this DOS command window, Fig. 35. Whenever MCNP has completed execution, this window was released and closed by windows, which raised an event within the Visual Basic code that MCNP had completed.

```

C:\Documents and Settings\nparham\My Documents\Visual Studio Projects\FunWithStu
ff\bin\Code\McNP>mcnp5 i=mcnp.inp o=mcnp.out
mcnp      ver=5      , ld=06212004  06/14/07 12:52:14
          Thread Name & Version = MCNP5_RSICC, 1.30
          Copyright LANL/UC/DOE - see output file

          MCNP5

warning. universe map (print table 128) disabled.

comment. lattice speed tally modifications will not be used.
comment.      8 surfaces were deleted for being the same as others.
comment. total fission nubar data are being used.
warning.  92 materials had unnormalized fractions. print table 40.
warning. vol/area for repeated structure tally  14 may be wrong.
warning. vol/area for repeated structure tally  24 may be wrong.
warning. vol/area for repeated structure tally  34 may be wrong.
warning. vol/area for repeated structure tally  44 may be wrong.
warning. vol/area for repeated structure tally  54 may be wrong.
warning. vol/area for repeated structure tally  64 may be wrong.
warning. vol/area for repeated structure tally  74 may be wrong.
warning. vol/area for repeated structure tally  84 may be wrong.

```

Fig. 35. DOS window running MCNP5

After this event, the Visual Basic code takes over again and begins the post-processing of the MCNP output file. This post-processing consists of extracting the flux information from the output file. This condensed flux information is stored in another text file for use later in the pre-processing of the ORIGEN2 input file.

With MCNP execution and post-processing complete NSCRFM moves on to pre-processing ORIGEN2. This ORIGEN2 input file contains three main sections, the first is the only section that does not change with every run. This contains information such as where to look for cross section data, comments about the input file, and information on how to read the input. The second section is the burn or decay section. The third is the materials information. Both of these sections are changed for every run and every rod.

The Visual Basic code steps through the database checking every core location for a fuel or control rod. When a fuel or control rod is found NSCRFM links to the serial number of the fuel or control rod that exists in that core location. With the serial number, NSCRFM uses the database relationship table to collect information like the MCNP cell number of that rod. The flux information stored from the post-processing of the MCNP deck links the cell number with the flux.

An ORIGEN2 constant flux irradiation command line consists of the length of the burn followed by the flux, and four identifiers for the vectors to read from, store information to, what units the time was in, and how to read the time. The Visual Basic code takes the condensed power log and the flux from MCNP and creates a list of these constant flux irradiation commands. The power log contains the power every minute for an entire day listed in units of watts. This information is condensed into ten minute sections with an average power listed. The flux from MCNP is multiplied by the condensed power log normalized to 1MW.

Because there are so many materials to list for each ORIGEN2 run the materials section was given its own input file. Within this file every isotope from the database linked to the serial number is put into ORIGEN2 format and into this file.

At this point ORIGEN2 pre-processing is complete, shell commands again take over concatenating these three text files into the ORIGEN2 input file and executing ORIGEN2. The shell command runs ORIGEN2 in a DOS window like MCNP, Fig. 36. This DOS window was watched by Visual Basic and its completion raised an event within Visual Basic to handle post-processing of ORIGEN2 output.

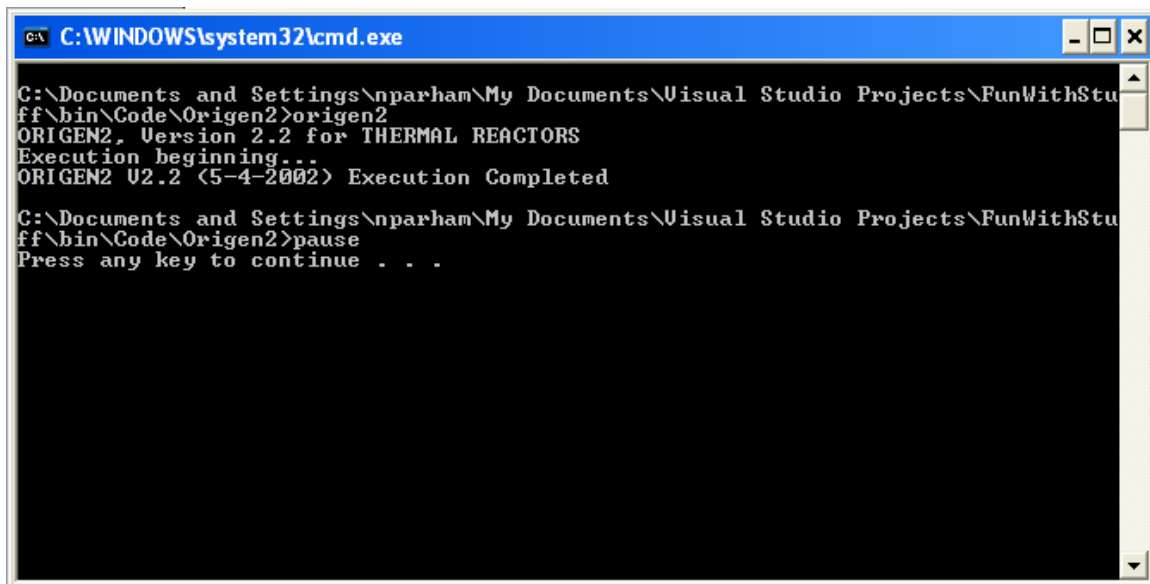
A screenshot of a DOS command window titled "C:\WINDOWS\system32\cmd.exe". The window shows the execution of the ORIGEN2 program. The prompt is "C:\Documents and Settings\nparham\My Documents\Visual Studio Projects\FunWithStuff\bin\Code\Origen2>origen2". The output is "ORIGEN2, Version 2.2 for THERMAL REACTORS", "Execution beginning...", and "ORIGEN2 U2.2 (5-4-2002) Execution Completed". The prompt then changes to "C:\Documents and Settings\nparham\My Documents\Visual Studio Projects\FunWithStuff\bin\Code\Origen2>pause", and the output is "Press any key to continue . . .".

```
C:\WINDOWS\system32\cmd.exe
C:\Documents and Settings\nparham\My Documents\Visual Studio Projects\FunWithStu
ff\bin\Code\Origen2>origen2
ORIGEN2, Version 2.2 for THERMAL REACTORS
Execution beginning...
ORIGEN2 U2.2 (5-4-2002) Execution Completed
C:\Documents and Settings\nparham\My Documents\Visual Studio Projects\FunWithStu
ff\bin\Code\Origen2>pause
Press any key to continue . . .
```

Fig. 36. DOS window running ORIGEN2

Post-processing of the ORIGEN2 output takes the updated isotopic information and inserts it into the database. This process consisted of searching the ORIGEN2 output for every material and updating each database entry with the new value from the ORIGEN2 output.

At this point Visual Basic has completed burning a single fuel or control rod, and updated the database to reflect those values. Visual Basic returns to the main table in the database and steps through the core locations to find the next fuel or control rod. Upon completion of all fuel and control rods with in the database, Visual Basic gives the user a

message informing them that NSCRFM has complete execution. Fig. 37 shows this message.



Fig. 37. Message box informing the user NSCRFM has completed

IV.D. Code Validation

This code was broken into pieces, such as subroutines, to handle pre-processing of MCNP input, post- processing of MCNP, pre-processing ORIGEN2 input, and post-processing ORIGEN2 output. These MCNP and ORIGEN2 decks needed to check to make sure their solutions were correct.

Since Texas A&M University had just received a new shipment of fuel, and this code models this new fuel, the MCNP deck created here was tasked with modeling this new core. This MCNP deck was used to calculate the flux and the reactivity worth's of the control rods; this calculated data was then compared to measured values. The NSCR was set up to irradiate samples in core locations D2, D3, D7, and all along the A row. For the interior core locations a pneumatic system places the samples at one-third the fuel height, which was where the flux reaches an axial maximum. Using cadmium covered gold foils the thermal flux can be measured since cadmium has a very large cross section for neutron absorption below 0.5 eV¹⁴. Two energy bins were created for tallies in MCNP, one from 0 to 0.5 eV, the thermal range, and the other from 0.5 eV to 20 MeV for

the fast flux. As one can see from Fig. 38 cadmium has a sharp cross section drop after ~ 0.2 eV. Tallies were made in the MCNP deck breaking each irradiation location into ten axial regions, as seen in Fig. 39. Gold foils were used to measure the flux in these locations.

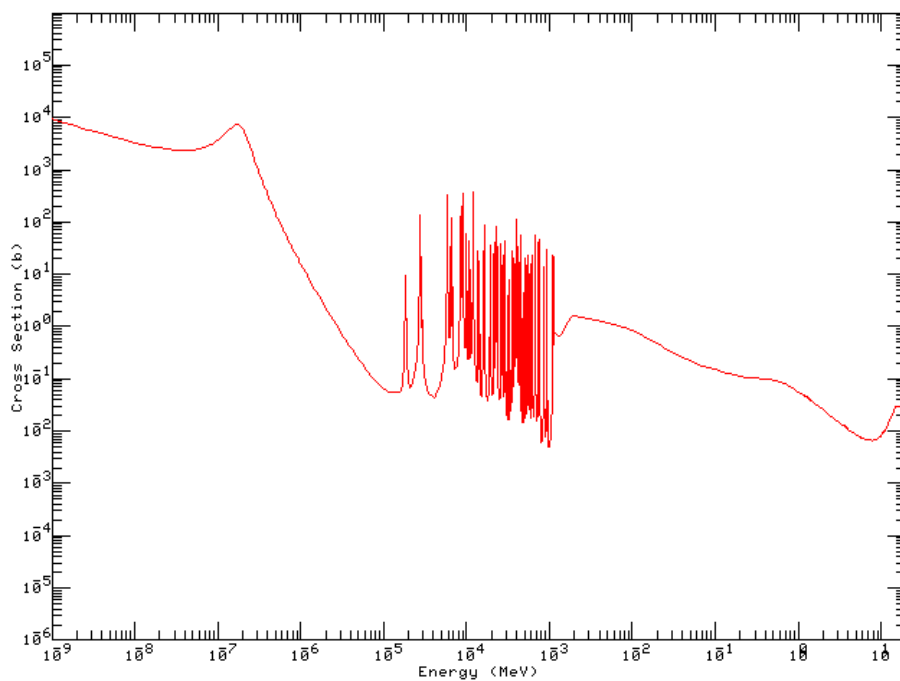

Fig. 38. Cadmium absorption cross section¹³

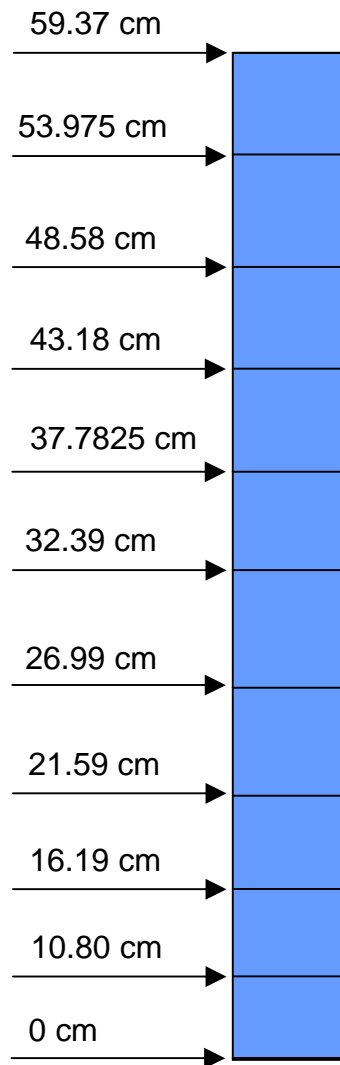

Fig. 39. Water column split into 10 sections for flux tallies

Again the flux calculated by MCNP was per source particle, multiplied by the 1MW conversion factor, this flux was compared to the measured data. The method for calculating the flux from measured data was neutron activation analysis. First, two gold foils were irradiated, one with a cadmium cover while the other is left bare. The activity of these gold foils was measured by high purity germanium detectors at the NSC, back calculations were done to get the activity when the sample was removed from the core,

this value was assumed to be the saturation activity of the gold foils. The saturation activity was defined as the maximum activity the material will ever reach, when absorption and burnup have reached equilibrium in the material. With these activities the fluxes could be calculated using two group cross sections from the Table of Nuclides⁹, the 2200 m/s and resonance cross sections.

$$\begin{aligned} A_o^{cd} &= N_a (I_\infty \phi_{epi}) \\ A_o^{bare} &= N_a (\sigma_{2200} \phi_{2200} + I_\infty \phi_{epi}) \end{aligned} \quad (11)$$

where here A_o was the saturation activity of the gold foils, N_a was the atom density of gold within the foil sample, ϕ_{epi} and ϕ_{2200} were two group fluxes epithermal for the fast group and 2200 m/s for the thermal group, while I_∞ and σ_{2200} were the two group cross sections for gold obtained from the Table of Nuclides. Within the Table of Nuclides the cross sections were listed as I_∞ or the resonance integral and the σ_{2200} which was the 2200 m/s cross section.

The 2200 m/s flux which was the thermal flux multiplied by the square root of Pi over two.

$$\phi_{Thermal} = \frac{2}{\sqrt{\pi}} \phi_{2200 \frac{m}{s}} \quad (12)$$

Equation (12) was derived from the fact that for $1/v_r$ absorbers in the thermal range the microscopic cross section could be written as the ratio of speeds to the ratio of the cross sections. Introducing this into a reaction rate equation yields

$$\text{Reaction Rate} = N \sigma_a (v_{r0}) n v_{r0} . \quad (13)$$

$$\frac{1}{2} m v_r^2 = kT \quad (14)$$

$$\phi_{2200\frac{m}{s}} = nv_{2200\frac{m}{s}} \quad (15)$$

Here N and n in equation (13) were the atomic and neutron densities respectively. The non relativistic equation for neutron speed as a function of temperature was given by equation (14). Substituting the ratio of neutron speeds at two temperatures T and $T_{2200m/s}$ into the definition of the flux given in equation (15) we obtain the relationship between the 2200 m/s flux and the flux at neutron energy¹⁰.

$$\phi_T = \frac{2}{\sqrt{\pi}} \left(\frac{T}{T_{2200\frac{m}{s}}} \right)^{\frac{1}{2}} \phi_{2200\frac{m}{s}} \quad (16)$$

Defining T here to be thermal energies or approximately room temperature equation (16) reduces to equation (12).

The theory here was that the cadmium covered foil would be irradiated by only the neutrons above 0.5eV and so its activity would depend only on the fast flux, while the bare foil's activity would depend on both the thermal and fast fluxes, this created a system of two linear independent equations (1).

Table X displays for comparison the measured flux values from the gold foil experiment versus the MCNP calculated values. As one can see these data agree well, helping to validate the NSCRFM code.

TABLE X
Thermal and Epi-Thermal Flux Comparison for Foil Measurement to MCNP Code

| | Thermal Flux from Foil Measurement | Thermal Flux from MCNP code | Epi-Thermal Flux from Foil Measurement | Epi-Thermal Flux from MCNP code |
|----|--|--------------------------------|--|------------------------------------|
| A2 | 1.840E+12 | 3.200E+12 | 6.890E+10 | 7.170E+10 |
| A4 | 5.000E+12 | 8.120E+12 | 1.706E+11 | 1.680E+11 |
| A6 | 5.410E+12 | 7.980E+12 | 2.184E+11 | 1.590E+11 |
| A8 | 2.240E+12 | 3.680E+12 | 7.125E+10 | 7.530E+10 |
| D2 | 7.500E+12 | 1.020E+13 | 2.400E+11 | 2.370E+11 |

This MCNP deck was also used to calculate the reactivity worth of each control rod in the core. Reactivity (ρ) was defined as the change in multiplication factor (k) over the multiplication factor. A simulation was done with all control rods completely removed from the core and the core next to the thermal column. Then the rod to be calculated was inserted into the core and the multiplication factor was calculated by MCNP. Here Table XI shows the control rod worth's calculated by this simulation.

$$\rho = \frac{\Delta k}{k} \quad (17)$$

TABLE XI
Reactivity of Control Rods in the NSCR

| | k_{eff} | | Reactivity ($\Delta k/k$) | | Reactivity (\$) | |
|-----------------------|------------------|---------|-----------------------------|------------|-----------------|-------|
| All Rods Out | 1.04209 ± | 0.00022 | | | | |
| SS 1 In | 1.02323 ± | 0.00022 | -0.01810 ± | 0.00030 | -2.585 ± | 0.043 |
| SS 2 In | 1.0318 ± | 0.00022 | -0.00987 ± | 0.00030 | -1.411 ± | 0.043 |
| SS 3 In | 1.02821 ± | 0.00022 | -0.01332 ± | 0.00030 | -1.903 ± | 0.043 |
| SS 4 In | 1.01394 ± | 0.00022 | -0.02701 ± | 0.00030 | -3.859 ± | 0.043 |
| Transient In | 1.01884 ± | 0.00022 | -0.02231 ± | 0.00030 | -3.187 ± | 0.043 |
| Regulating In | 1.0321 ± | 0.00023 | -0.00959 ± | 0.00031 | -1.370 ± | 0.044 |
| SS4 and RR out | 0.99338 | 0.00022 | -0.00662 | 4.2307E-05 | -0.946 | 0.006 |
| Total | | | -0.10020 ± | 0.00073 | -14.315 ± | 0.105 |

The fluxes calculated by MCNP and the fluxes measured from the NSCR agreed quite well. Control rod worths also agree well with the expected values³. These analyses show, by their agreement with data, that the MCNP deck created by NSCRFM was an accurate simulation of the NSCR.

To prove that the ORIGEN2 deck created by the Visual Basic code simulated the NSCR system accurately, an ORIGEN2 input deck was created by NSCRFM while another deck was created for comparison. NSCRFM created ORIGEN2 deck uses the constant flux irradiation while the ORIGEN2 deck created by hand used the constant power irradiation with varying power to match the same flux used in the other deck. Both decks simulate burning the reactor for one year. The results from this analysis were given in Table XII. As one can see the two ORIGEN2 decks predict very similar values for the tracked isotopes within the core. Here the amounts of isotopes were given in units of grams with an original load of 1MT of uranium metal similar to the ORIGEN2 decks made for the cross section library comparison. Also shown here in Fig. 40 and Fig. 41 are plots of ^{235}U and ^{239}Pu to show that the Visual Basic code generates ORIGEN2 decks that behave as expected, meaning the ^{235}U was being depleted and the ^{239}Pu was building up in the fuel material. Table XII provides a comparison of between the total burnup calculated by ORIGEN2 and NSCRFM.

Fig. 40. Burnup of ^{235}U Fig. 41. Burnup of ^{239}Pu

TABLE XII
Grams of Select Isotopes from ORIGEN2 Decks Generated by NSCRFM

| Isotope | ORIGEN2 (Grams/MTU) | NSCRFM (Grams/MTU) |
|-------------------|------------------------|-----------------------|
| ²³⁵ U | 1.97E+05 | 1.97E+05 |
| ²³⁸ U | 8.00E+05 | 8.00E+05 |
| ²³⁹ Pu | 4.27E+02 | 4.30E+02 |
| ²⁴⁰ Pu | 1.84E+00 | 1.85E+00 |
| ¹⁶⁶ Er | 9.96E+03 | 9.96E+03 |
| ¹⁶⁷ Er | 6.73E+03 | 6.73E+03 |

V. CONCLUSION

The purpose of this work was to create a program that could track the isotopes of the NSCR and that could be tracked with reasonable accuracy. This program needed to run with as little user input as possible and minimal impact on the daily operation of the reactor as little as possible. These criteria were met by creating a Visual Basic program that links MCNP and ORIGEN2 together to calculate depletion and buildup of isotopes within the fuel based on automatically read daily power logs for the NSCR.

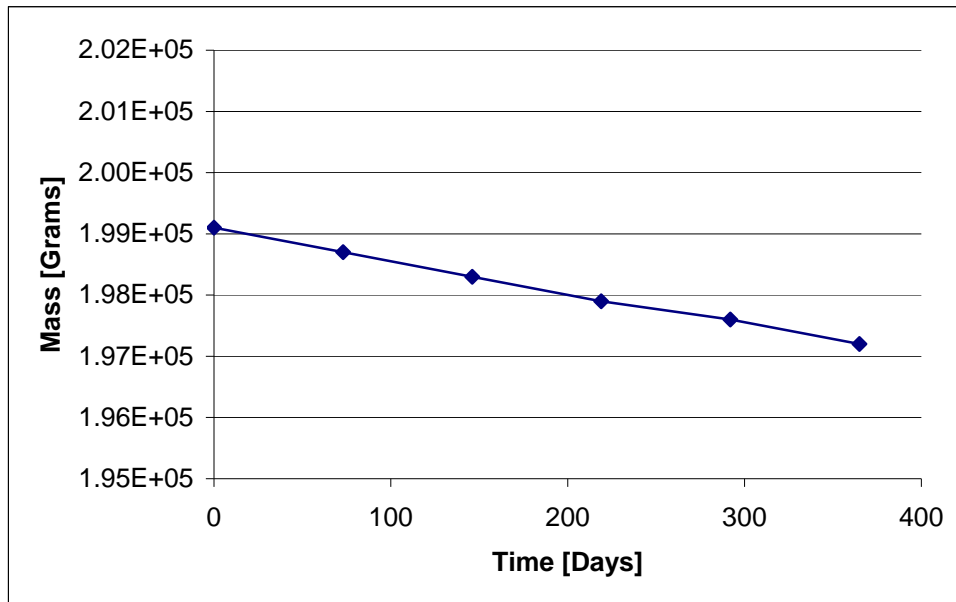
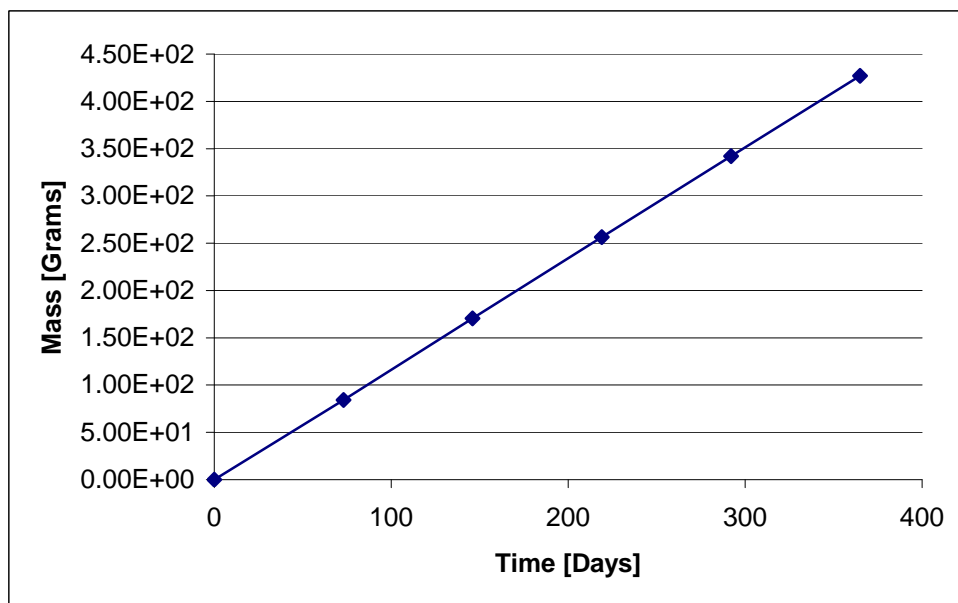
The capability to pre-process MCNP input files within NSCRFM was generated. This process required the creation of a user interface to allow for changes to the core layout before Visual Basic created the MCNP input deck. Many simulations were run with this MCNP deck to verify that it provides an accurate model of the NSCR. These simulations include flux comparison where the model agreed with measured data, rod worth calculations that agreed with the technical specifications for the NSCR and agreed with previous work and pin cell tests to determine that a single radial fuel region had sufficient accuracy for NSCRFM's purposes.

The capability to pre- and post-process ORIGEN2 files was created within the Visual Basic code to handle the execution of an ORIGEN2 run for every fuel and control rod in the core. This ORIGEN2 input deck required the creation of a cross section library for a TRIGA style reactor since within the basic ORIGEN2 libraries none existed. Monteburns was used with the MCNP deck to produce this cross section library.

With NSCRFM completed its results were compared to that of ORIGEN2 decks created by hand to validate that the code was operating as expected.

NSCRFM performs its function with reasonable accuracy. It gathers minimal information from the user and burns the core over daily operation. After execution it stores all material data to the database for further use within NSCRFM or for isotopic report generation. Additional work can be done in the area of creating a diffusion code to predict fuel movement for optimizing various core parameters such as the core lifetime or flux in the irradiation locations.

REFERENCES

1. Joint Statement by President Bush and President Putin on Nuclear Safety Cooperation, February 24, 2005.
<http://www.whitehouse.gov/news/release/2005/02/20050224-8.html>.
2. Safety Evaluation Report on High-Uranium Content, Low-Enriched Uranium Zirconium Hydride Fuels for TRIGA Reactors, NUREG-1282, U.S. Nuclear Regulatory Commission (1987).
3. Safety Analysis Report for the Nuclear Science Center Reactor Texas A&M University, Texas Engineering Experiment Station, R-83, U.S. Nuclear Regulatory Commission (2003).
4. Docket No. 50-128, “Issuance of Order Modifying License No. R-83 to Convert from High- to Low-Enriched Uranium Fuel (Amendment No. 17)” (September 2006).
5. J.R. LAMARSH, *Introduction to Nuclear Reactor Theory*, Addison-Wesley, Old Tappan NJ, (1966).

6. A G. CROFF, *A User's Manual for the Origen2 Computer Code*, ORNL/TM-7175, Oak Ridge National Laboratory, Oak Ridge, TN (1980).
7. D. L. POSTON and H. R. TRELLE, *Users Manual, Version 2.0 for MONTEBURNS Version 1.0*, LA-UR-99-4999, Los Alamos National Laboratory, Los Alamos, NM (1999).
8. *MCNP – A General Monte Carlo n-Particle Transport Code, Version 5*, LA-UR-03-1987, Los Alamos National Laboratory, Los Alamos, NM (April 2003, Revised November 2005)
9. M. BADEA et al., “Improved $S(\alpha, \beta)$ Tables for TRIGA Criticality and Reactivity Feedback Calculations,” Institute for Reactor Safety, Forschungszentrum Karlsruhe, Germany (2005).
10. B. REARDEN, *Engineering Analysis of a Power Upgrade for the Texas A&M Nuclear Science Center Reactor*, M.S. Thesis, Texas A&M University (August 1995).
11. R. CANDALINO, *Engineering Analysis of Low Enriched Uranium Fuel using Improved Zirconium Hydride Cross Sections*. M.S. Thesis, Texas A&M University (October 2006).

12. J.J. DUDERSTADT AND L.J. HAMILTON, *Nuclear Reactor Analysis*, Wiley Publishing, Hoboken NJ (1976).
13. Table of Nuclides; available on <http://atom.kaeri.re.kr/index.html> (2000).
14. E. BRAUM, H. KNOX, AND T. MILLER, *Nuclides and Isotopes*, Edition 16, KAPL, Inc. (2002).
15. Docket No 50-128, “Technical Specification for the Nuclear Science Center Reactor Facility License No. R-83” (March 1983).
16. W. WHITTEMORE, Personal Communication, General Atomic, (October 2005).

VITA

Neil Aubrey Parham was born in Houston, Texas on September 17, 1980. He is the son of Gene and Jan Parham who reside in Deer Park, Texas. After graduating from Deer Park High School in 1999, he attended Texas A&M University and received a B.S. in nuclear engineering in 2004. He continued his education at Texas A&M University for a M.S. in nuclear engineering and graduated in May of 2010.

His permanent address is the following:

Department of Nuclear Engineering

Texas A&M University

3133 TAMU

College Station TX 77843-3133