

NEWASH AND TECUMSETH: ANALYSIS OF TWO POST-WAR OF 1812 VESSELS
ON THE GREAT LAKES

A Thesis

by

LEEANNE ELIZABETH GORDON

Submitted to the Office of Graduate Studies of
Texas A&M University
in partial fulfillment of the requirements for the degree of

MASTER OF ARTS

May 2009

Major Subject: Anthropology

NEWASH AND TECUMSETH: ANALYSIS OF TWO POST-WAR OF 1812 VESSELS
ON THE GREAT LAKES

A Thesis

by

LEEANNE ELIZABETH GORDON

Submitted to the Office of Graduate Studies of
Texas A&M University
in partial fulfillment of the requirements for the degree of

MASTER OF ARTS

Approved by:

Chair of Committee,	Kevin J. Crisman
Committee Members,	Troy O. Bickham
	Donny L. Hamilton
Head of Department,	Donny L. Hamilton

May 2009

Major Subject: Anthropology

ABSTRACT

Newash and *Tecumseth*: Analysis of Two Post-War of 1812 Vessels on the Great Lakes.

(May 2009)

LeeAnne Elizabeth Gordon, B.A., Auburn University

Chair of Advisory Committee: Dr. Kevin J. Crisman

In 1953 the tangled, skeletal remains of a ship were pulled from the small harbor of Penetanguishene, Ontario. Local historians had hoped to raise the hull of a War of 1812 veteran, but the vessel pulled from the depths did not meet the criteria. Identified as H.M. Schooner *Tecumseth*, the vessel was built just after the War of 1812 had ended.

Historical research of *Tecumseth* and her sister ship *Newash*, which remained in Penetanguishene harbor, illuminated the ships' shadowy past. Conceived and built after the war, the vessels sailed for only two years before being rendered obsolete by the terms of the Rush-Bagot disarmament agreement. Nevertheless, the two vessels offer a unique perspective from which to view the post-war period on the Great Lakes.

The schooners' hulls were interpreted and analyzed using archaeological evidence. A theoretical rigging reconstruction was created, using contemporary texts and documentary evidence of the ships themselves. Architectural hull analysis was carried out to explore the nature of these vessels. From these varied approaches, a conception of

Newash and *Tecumseth* has emerged, revealing ways in which the hulls were designed to fulfill their specific duties. The hulls were sharp, yet had capacious cargo areas. The rigs combined square-rigged and fore-and-aft sails for maximum flexibility. The designs of the hulls and rigging also reflect predominant attitudes of the period, in which naval vessels on the lakes gave way to merchant craft.

Taken as a whole, *Tecumseth* and *Newash* illustrate how ships, while fluid in the nature of their work, are also singular entities that truly encapsulate a specific point in time and place.

“If you are flammable and have legs, you are never blocking a fire exit.”

-Mitch Hedberg

ACKNOWLEDGMENTS

The preparation of this thesis could not have been done without the tremendous assistance of many people who have contributed in various ways. I wish to thank, in no particular order: Marita and the staff of the Penetanguishene Public Library; Mike Seraphin and the staff of Discovery Harbour (Havre de la Découverte); Erich Heinold, Chris Sabick, Eric Emery, Brian Atchison and the other student archaeologists who took part in the surveys of *Tecumseth* and *Newash* in 1997 and 1998; Mr. John R. Stevens; Captain Walter Rybka, of the U.S. Brig *Niagara*; Captain Jamie Trost, of the topsail schooner *Pride of Baltimore II*; Captain Tiffany Krihwan, of the schooner *Denis Sullivan*; the irrepressible and unflappable Ms. Carrie Sowden, to whom I am forever in debt, financially and otherwise; Mrs. Elizabeth Hutchinson; the thesis committee, Drs. Kevin J. Crisman, Donny L. Hamilton and Troy O. Bickham; my underrated fellow students: Heather Brown, Carlos Cabrera, Claire Collins, Ben Ford, Heather Hatch, Brad Krueger, Ryan Lee, John Littlefield, Bridget McVae, Drew Roberts and Will Moser; my mom and dad, grandma and grandpa; and of course, the makers of Giant Eagle Bavarian ham, Lemonheads and, certainly, Dr. Pepper.

TABLE OF CONTENTS

	Page
ABSTRACT	iii
DEDICATION	v
ACKNOWLEDGMENTS.....	vi
TABLE OF CONTENTS	vii
LIST OF FIGURES.....	xi
LIST OF TABLES	xiv
NOMENCLATURE.....	xv
CHAPTER	
I INTRODUCTION: THE ROYAL NAVY IN CANADA AND THE TREATY OF GHENT	1
II TWO SHARP SCHOONERS	18
III MASTING AND DISMASTING	30
IV LIFE ABOARD THE SCHOONERS	42
V THE <i>NEWASH-MINK</i> INCIDENT AND BORDER RELATIONS	50
The Case of Lieutenant Alexander Vidal.....	53
Seizure of <i>Julia</i>	55
Customs House Boats on Lake Champlain.....	56
VI WINTER ON LAKE ERIE	58
Re-Rigging the Ships	62
Life at Grand River	64
Crossing the Bar	65
Later Seasons for the Vessels.....	69

CHAPTER	Page
VII	CAPTAIN WILLIAM BOURCHIER AND THE DISARMAMENT OF THE GREAT LAKES..... 71
	The Rush-Bagot Agreement..... 77
VIII	DECAY AT PENETANGUISHENE..... 81
IX	ARCHAEOLOGICAL AND HISTORICAL RESEARCH..... 87
	The 1953 Salvage of <i>Tecumseth</i> 88
	Early Publications 91
	1970s Examination and Conservation Efforts..... 92
	1997 – 1998 Archaeology 94
	2007 – 2008 Investigations 98
X	ARCHAEOLOGICAL EVIDENCE OF THE SCHOONERS’ CONSTRUCTION 99
	Keels and Posts..... 100
	Deadwood..... 108
	Frames 109
	Keelsons, Stemsons and Sternsons..... 111
	Mast Steps 112
	Mast Section..... 116
	Pump Wells and Limber Holes 117
	Clamps, Deck Beams, Waterways and Wales..... 118
	Chainplates 124
	Planking the Ships..... 126
	<i>Newash</i> and <i>Tecumseth</i> and War of 1812-Era Ship Construction 128
XI	HULL ANALYSIS 134
	Design Lines..... 135
	Coefficients and Ratios 144
	Waterplane Area and Immersion..... 149
	Deck-Edge Immersion and Downflooding..... 150
	Tender and Stiff Vessels 152
	Discussion: Hull Design and Purpose 153
	Penetanguishene’s Sailing Replica..... 155

CHAPTER	Page
XII RECONSTRUCTING THE SCHOONER RIG.....	158
Main Rigging.....	164
Fore Rigging.....	166
Bowsprit Rigging	168
Trestletrees, Crosstrees and Mast Caps.....	170
Topmast Rigging.....	170
Topgallant Rigging.....	173
Jibboom Rigging	174
Main Yards and Spars	176
Fore Yards and Spars	185
Running Rigging	188
Discussion: Rigging and Manpower	193
XIII SAILS AND SAILING	197
Sail Plan and Area.....	200
Mast Placement	205
XIV RECONSTRUCTION OF THE BRIGANTINE AND SCHOONER II RIGS.....	209
The Conversion Factor	213
Gaff Topsails and Main Topmast Staysails.....	214
XV CONCLUSIONS AND COMMENT.....	216
NOTES.....	221
REFERENCES.....	244
APPENDIX A TREATY OF GHENT	253
APPENDIX B SCHOONER SPARS AND SAILS	262
APPENDIX C RUSH-BAGOT AGREEMENT	265
APPENDIX D TABLE OF COEFFICIENTS FOR SELECT VESSELS, 1800 - 1832.....	268
APPENDIX E “AN ACCOUNT OF RIGGING AND SAILS BELONGING TO HIS MAJESTY’S SCHOONER <i>NEWASH</i> ”	271

	Page
APPENDIX F SPAR LENGTH PROPORTIONS FROM HOWARD I. CHAPELLE'S <i>THE BALTIMORE CLIPPER</i>	276
APPENDIX G E-MAIL COMMUNICATION FROM CAPTAIN WALTER RYBKA ON THE USE OF HEARTS AND DEADEYES	277
VITA	279

LIST OF FIGURES

FIGURE		Page
1	Map of the Great Lakes, showing locations of pertinent points.....	3
2	Draft of <i>Newash</i> and <i>Tecumseth</i>	15
3	Map of the Niagara Peninsula	17
4	Angle of deadrise	19
5	Deck layout, showing placement of pivot guns and carronades	21
6	A pivot gun.....	22
7	A carronade	22
8	A long gun	22
9	“The Dual Launching of the <i>Newash</i> and the <i>Tecumseth</i> .”	29
10	Stepping masts with sheers.	31
11	Single luff tackle	66
12	Double luff tackle.....	67
13	Penetanguishene Harbor with <i>Tecumseth</i> and <i>Newash</i> , “31” and “32,” in ordinary	82
14	<i>Tecumseth</i> on the beach in Penetanguishene, 1953.....	90
15	Wreck plan of <i>Newash</i> remains.....	96
16	Wreck plan of <i>Tecumseth</i> remains	97
17	Bow assembly of large contemporary vessels.....	101
18	Boxing scarf	102
19	Photo of <i>Tecumseth</i> ’s bow assembly, starboard face.....	103

FIGURE	Page
20 Drawing of <i>Tecumseth</i> 's bow assembly, port face.....	104
21 Drawing of <i>Tecumseth</i> 's port horseshoe plate.....	105
22 Maker's mark on <i>Tecumseth</i> 's port horseshoe plate.	106
23 Stern assembly of <i>Newash</i>	107
24 Hook scarf in <i>Tecumseth</i> 's keelson.....	112
25 Plan view of <i>Tecumseth</i> 's stemson, showing the convoluted grain of the wood.....	113
26 Drawing of <i>Tecumseth</i> 's main mast step.....	114
27 Detail of <i>Newash</i> 's main mast step, circled.....	116
28 Plan view of <i>Tecumseth</i> 's deck beam.....	119
29 Drawing of disarticulated timber from <i>Newash</i> , identified as a clamp/waterway but possibly an exterior plank with chainplates attached.....	121
30 Reconstructed midship section of H.M. Schooner <i>Tecumseth</i>	123
31 Historian Rowley Murphy holding chainplate on <i>Tecumseth</i> in 1953.....	125
32 Revised lines drawing, showing two additional waterlines and two additional buttock lines.	136
33 Angle of entrance in bow.....	139
34 Distance between midships section and center of load waterline.....	141
35 Angle of deck-edge immersion.....	152
36 John R. Stevens' reconstructed rigging plan.....	159
37 Reconstructed schooner rigging plan.	160
38 Larboard deadeye.....	163

FIGURE		Page
39	Rigging heart.....	163
40	A two-fold purchase.....	165
41	Lanyard and Matthew Walker knots.....	167
42	Mast cap.....	171
43	Swiftering in shrouds.....	173
44	Flying jib stay set-up with traveler ring.....	176
45	Throat and peak halyard assemblies.....	178
46	Boom lift assemblies.....	180
47	Lazy guy assemblies.....	181
48	Lower yard lift assemblies.....	183
49	Sister block.....	186
50	Topsail showing cluelines rigged.....	189
51	Topsail showing cringles.....	189
52	Bowline assembly.....	191
53	Hypothetical sail plan of original rig.....	201
54	Center of lateral body.....	204
55	Draft showing predicted fore and main mast placement, in gray.....	206
56	Studdingsails.....	212

LIST OF TABLES

TABLE		Page
1	Boats and Batteaux Belonging to Lake Erie Establishment, 31 December 1815	61
2	Hull Dimensions.....	144
3	Dimensions of Masts	162
4	Dimensions of Yards and Spars	177
5	Hypothetical Sails and Sail Area.....	202

NOMENCLATURE

LAC – Library and Archives of Canada

PRO – Public Record Office

CHAPTER I

INTRODUCTION: THE ROYAL NAVY IN CANADA AND THE TREATY OF GHENT

The Treaty of Ghent officially ended the War of 1812 when it was signed on Christmas Eve 1814.¹ Peace was initially slow to spread, however. When news of the treaty reached Commodore James Lucas Yeo, senior British officer on the lakes of Canada, he was little fazed. He did not immediately call for a removal of all troops in Canada, or for transport ships to convey men back to their homes in Great Britain. Peace between the United States and Great Britain had been under negotiation in Europe for some time, and Yeo knew that peace was easier to achieve in a document than on a gundeck. At the time of the treaty, Yeo was stationed at a location that could not be easily abandoned.

“The situation in 1815 still call[ed] for the maintenance of military and naval measures designed to prevent an easy conquest of Canada by the United States.”² The American desire to conquer Canada had manifested itself during the War of 1812, and led to several unsuccessful American incursions into territory north of the border. The British, often with the aid of native tribes, managed to repulse each invasion. Still, the British were not eager to leave the frontiers, particularly those along the Great Lakes, which offered a watery passage into Canadian lands, undefended.

¹This thesis follows the style of *International Journal of Naval History*.

Commodore Yeo was appointed the commander of His Majesty's Naval Forces on the Lakes of Canada in March 1813, just in time to oversee some of the most brutal hostilities on the lakes. Yeo was stationed at Kingston, at the northeastern end of Lake Ontario (fig. 1). Kingston was the key base for the Royal Navy and the headquarters of its operations in Upper Canada. From Kingston the Royal Navy could keep tabs on vessels approaching the Saint Lawrence River, as well as traffic on Lake Ontario. Overland routes linked Kingston to Montreal and Quebec to the east, and fortifications on the Niagara Escarpment and peninsular Upper Canada to the west. Importantly, the position at Kingston allowed the British to keep a close eye on Sackets Harbor, the home of American shipbuilding on Lake Ontario. These bases had been the scene of a shipbuilding race throughout most of the war, with each side racing to build more and larger ships than the other in order to achieve ascendancy on the lake.

Yeo was acutely aware of the strategic importance of the lakes of Canada both to the British and the Americans. On either side of the contested border, the Great Lakes and the Saint Lawrence River formed a vital highway for communication and commerce. In war, the water routes had been used to transport troops to distant outposts and keep them supplied. In peace, the same routes connected loyal settlers on the frontier, providing needed goods and facilitating trade. Control over, or at least a strong force upon, these waterways was critical to Great Britain's continued presence in Upper Canada, and important to future American expansion as well. In early 1815 Yeo was certain that naval strength would be maintained by both nations. Prior to receiving word of the

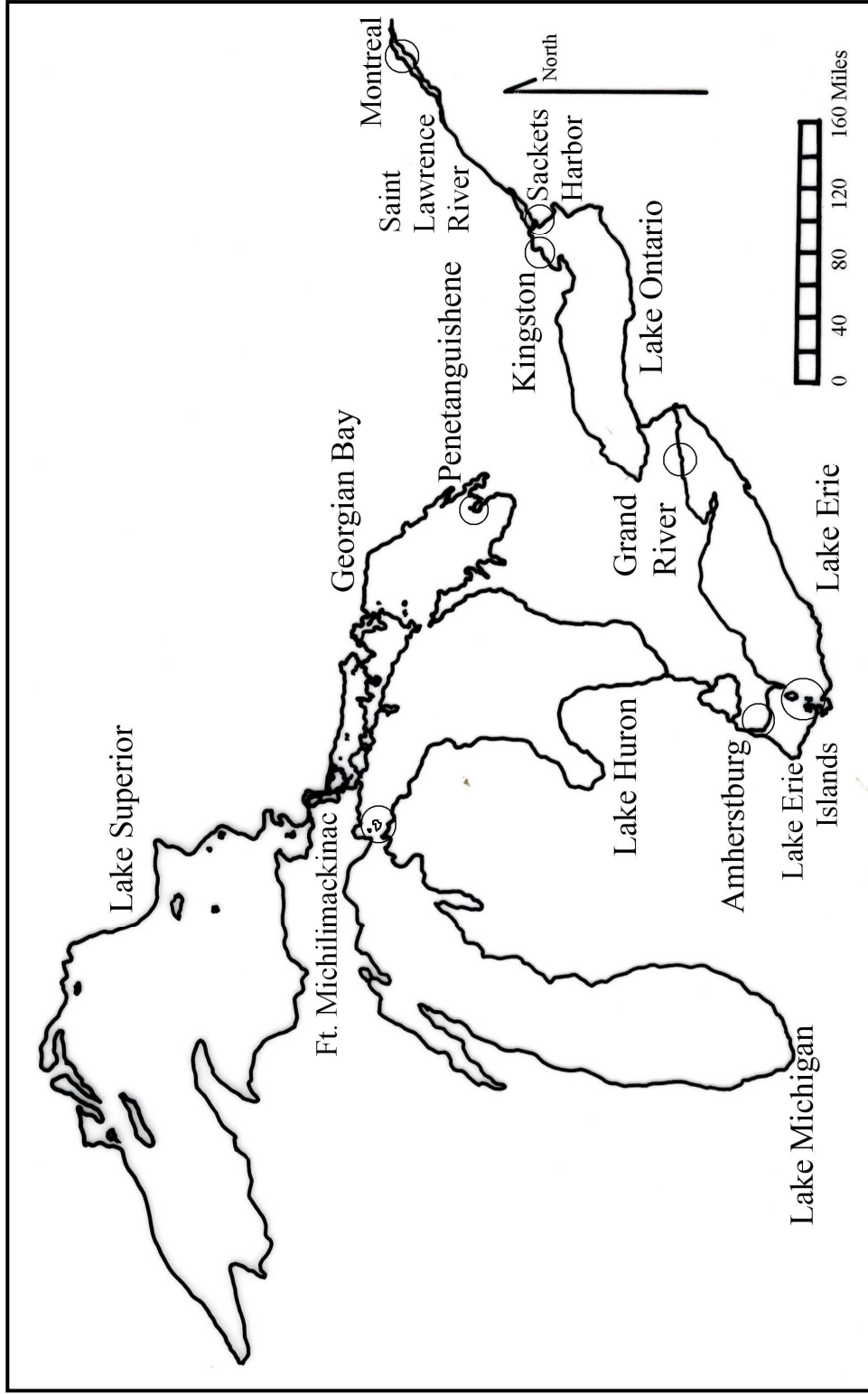

Figure 1: Map of the Great Lakes, showing locations of pertinent points.

treaty, and anticipating future hostilities, he had ordered a number of vessels to be constructed on Lakes Champlain, Ontario, Erie and Huron, as well as at Montreal on the Saint Lawrence River. While he awaited further orders from the Navy Board in London on whether to proceed with these new vessels, Yeo recommended that construction continue, “to keep pace with the Americans.”³

The end of the war brought a personnel change for the British. Commodore Yeo was relieved by Commodore Edward William Campbell Rich Owen, while George Prevost, who had overseen the British Army in Canada during the war, was succeeded by Sir Gordon Drummond. In spite of the change in commanding officers, the British mission remained unchanged. Lord Henry Bathurst, Secretary of State for War and the Colonies, addressed Drummond as he took command of His Majesty’s Forces in Canada. Bathurst instructed, “[Y]ou will direct Your chief attention to maintaining an ascendancy on the Lakes.”⁴ The new vessels ordered by Yeo and overseen by Commodore Owen were instrumental to this operation.

E.W.C.R. Owen⁵ was born in 1771, the son of Royal Navy Captain William Owen. From the time he was just four years old, he was listed in the logbooks of His Majesty’s vessels. He passed the lieutenant’s exam in 1793 and became a post captain in 1798. A career naval officer, E.W.C.R. Owen served off the coast of France during the Napoleonic wars and superintended an attack on Boulogne in 1806. He was awarded the

insignia of a Knight Commander of the Bath in 1815. During that same year, he became senior officer on the lakes of Canada.⁶

Upon succeeding Yeo, E.W.C.R. Owen set about assessing the state of the navy on the lakes. Commodore Owen received and analyzed dispatches from the distant bases in Upper Canada that fell under his jurisdiction. A party under the command of E.W.C.R. Owen's brother, Captain William Fitz William Owen, was sent to survey and report on uncharted portions of the lakes. Accounts from the outposts and the survey party enabled E.W.C.R. Owen to assemble a collection of observations relative to the natural resources available in Canada, as well as the requisite forces necessary for their protection.

British embarrassments on the lakes during the war – specifically the defeats on Lake Erie and Lake Champlain in 1813 and 1814 – had taken their toll on the Royal Navy, and it was determined not to repeat such events in any future war. E.W.C.R. Owen prepared an estimate of the desired naval force on the lakes, which was certainly influenced by Yeo's own appraisals. In spite of the Treaty of Ghent, the estimate was for a "war" complement of men and vessels; the peacetime establishments on the Great Lakes would ideally be ready for war at any time. The plan called for the construction of several massive warships, which would be manned by large crews.

The proposed war establishment included three 114-gun ships of the line on Lake Ontario, as well as three 60-gun frigates, two 28-gun corvettes and two 20-gun brigs. Lake Erie would have been home to a smaller force, consisting of five gunboats mounting 24-pounder long guns and large carronades, and three 44-gun frigates, to be built on a plan similar to H.M.S. *Princess Charlotte*. Another small flotilla was to serve on the River Thames, a river in peninsular Upper Canada that ran into Lake Saint Clair. Two more frigates were to be constructed on Lake Huron, as well as four schooner-rigged transports capable of carrying four guns each, and another smaller transport. The total number of men stationed on each lake was to be 6230 on Lake Ontario, 1280 on Lake Erie and 800 on Lake Huron.⁷

These new vessels were to be outfitted with the latest developments in naval ordnance: carronades and Congreve guns. Both developments were improvements on the traditional long gun. The carronade, introduced in the late 18th century, was a shorter, thinner-walled weapon capable of hurling heavy shot, but only over short distances. Some of the carronades planned for the Great Lakes would have been capable of throwing 68 pounds (30.84 kg) of iron with each blast. The Congreve gun was an adaptation of the long gun, the result of experimentation by William Congreve. Congreve hoped to increase effective ranges of guns without reducing the weight of shot. Initial tests of Congreve's new design showed that the projectiles had extraordinarily long ranges but low velocities.⁸ The vessels of E.W.C.R. Owen's plan

would have carried a combination of carronades, Congreve guns and long guns, making the British presence on each lake a truly frightening one.

Without an active war, E.W.C.R. Owen's proposed vessels, establishments and weapons were outlandish and expensive, and the Royal Navy never achieved such numbers – of ships, men or armament – on the lakes. Before the end of the War of 1812, however, some vessels had been ordered and, in a few places, construction had already begun. At Kingston, the 112-gun H.M.S. *St. Lawrence* had been launched in September 1814; a 56-gun ship, H.M.S. *Psyche*, was launched in December. The keels for two more large ships had been laid by early 1815. Construction of a frigate for use on Lakes Huron and Erie was planned at Penetanguishene, on Georgian Bay, and two brigs were underway at Montreal.⁹

E.W.C.R. Owen had inherited a precarious perch in Canada. He was to organize and maintain a peacetime complement of men and ships to be ready for future war at any moment. He was also tasked with uniting and supplying distant posts without incurring needless expenses. Logistical problems added to Owen's difficulties, since the rivers which connected the lakes to each other and to the sea were filled with rapids or waterfalls, making navigation impossible in some places.

Owen's jurisdiction included the Canadian shores of the Saint Lawrence River and Lakes Champlain, Ontario, Erie, and Huron. Not only was he responsible for

overseeing naval ships on those waterways, but he also had to coordinate with land-based troops in adjacent regions. The rough terrain of the Canadian interior necessitated a waterborne transport system for the conveyance of men and supplies. The Royal Navy was of primary importance in all discussion of Canadian defense. As new military posts were situated and constructed on the frontier, anchorages and docking facilities were given consideration. When British troops were removed from Fort Michilimackinac, for example, the fort was returned to the Americans and a new base was established in British territory, after the site was approved by a naval official.¹⁰

Each of the border waterways shared some portion of its shore with American territory, and the Treaty of Ghent had promised both nations free navigation of the waters. The close proximity of a former enemy was an unusual situation for the British Navy. Cut off as Britain was from the rest of Europe, the Royal Navy was more familiar with having expanses of open water separating its home ports from potential aggressors. The size of the Great Lakes, by comparison, gave the British opportunity to keep close watch on American activities, but also left them exposed to the prying eyes of American spies. Most of the action on the lakes during the War of 1812 took place only after each of the navies had exhausted its ability to build and launch more ships than the other. On Lake Ontario, focal point of the shipwrights' war, tensions never fully came to a head as each country waited to engage the other until it was assured of having supreme firepower. The north-south water highway of Lake Champlain lay mostly within American territory, but the British could not afford to relinquish control of the entire lake.

Maintaining at least one naval base on the water was considered necessary to keep Americans from encroaching into Canada. The same theory forced the British to retain outposts on Lake Ontario and the far reaches of Lakes Erie and Huron, despite the difficulties of transporting stores to support them.

The physical nature of these areas alone presented a logistical nightmare.

Geographically, nearly every body of water was rendered a separate entity by features that prevented navigation between them. The Saint Lawrence River was effectively two different rivers during the early 19th century. The Lachine rapids above Montreal bisected the river and prevented continuous navigation along its length, limiting vessels on the upper Saint Lawrence River and Lake Ontario to those built there. Lake Ontario functioned as its own entity, cut off from the upper lakes as well as any outlet to the Atlantic Ocean. The Niagara River, with its impassable falls, made transportation by land over the Niagara Escarpment the only option for traveling between Lakes Erie and Ontario. From Lake Erie, it was possible to reach Lakes Huron and Michigan and ships could be constructed on either lake for service on all.¹¹ The Great Lakes region was essentially a series of landlocked waterways.

Construction of canals would eventually link the waters of Upper Canada. A canal system to bypass the Lachine rapids had been proposed late in the 17th century, but was yet to be constructed by 1815. The British Government returned to the idea, and expanded upon it immediately following the close of the war.¹² Geographic difficulties

had prevented them from establishing and retaining an upper hand on the disparate waters of the Great Lakes. Canalization would facilitate the mobility of military and naval forces in Canada by avoiding geographical limitations. Construction of locks to bypass the Lachine rapids began in the years after the peace agreement, along with construction of the Rideau and Welland canals, which linked Ottawa to Lake Ontario and Lakes Erie and Ontario, respectively.¹³

At the end of the war, however, canals in Upper Canada were still unknown. A more immediate solution was to construct more ships. Because ships could not sail into Lake Ontario from other British outposts, Yeo had ordered two 74-gun ships to be built at Kingston, for service on Lake Ontario. An establishment was also created on Penetanguishene Bay, at the southern end of Georgian Bay, upon the recommendation of Sir Robert Hall, Commissioner of the Kingston dockyard. Hall wrote: "The necessity of having some naval force on Lake Huron capable of giving protection to the trade of the Northwest Company and preventing any incursions of the Enemy from Lake Erie through the River St. Clair has induced me to suggest...a naval establishment in Penetengushene [sic]."¹⁴ The new establishment was located at the southern end of Georgian Bay, where construction was to begin on several vessels. These vessels could serve on either Lake Huron or Lake Erie, since a navigable passage existed between them, via Lake Saint Clair and the Saint Clair and Detroit rivers.

Though small, Penetanguishene Bay offered an enviable place for ship construction. A shore battery easily defended the narrow, steep-sided inlet. The facilities at Penetanguishene were situated on the eastern side of a spit of land reaching into Georgian Bay, keeping any new vessels out of sight of casual shipping traffic. In addition, the surrounding area provided ample timber for shipbuilding and the bay was deep enough to launch even large vessels. Yeo had ordered two schooners and four gunboats to be ready by the opening of navigation in 1815.¹⁵ In early 1815 British naval presence on the upper lakes was particularly weak.

The Royal Navy in Upper Canada had been devastated by the Battle of Lake Erie on 10 September 1813. American forces had captured the entire British Lake Erie squadron. The defeat left the British forces in desperate want of naval ships on the upper lakes. The British were able to make good some of the losses with the capture of four small schooners in two separate expeditions in 1814. Lieutenant Miller Worsely, former commander of H.M. Schooner *Nancy*, seized the American schooners *Scorpion* and *Tigress* on Lake Huron. Renamed *Confiance* and *Surprize*, the schooners were purchased by the British Army for use by the Royal Navy in carrying supplies. Captain Alexander Dobbs also captured two American schooners, *Ohio* and *Somers*, on Lake Erie. The two hulls were sunk at the mouth of the Chippewa River to block the entrance from American traffic. By spring 1815, plans were made to raise the two hulls and return them to service as transports on Lake Erie.¹⁶

Transportation of men, supplies and even news, both on and off the lakes was a tremendous problem. The Battle of New Orleans has always been an ironic postscript to the War of 1812, fought after the treaty ending the war had been signed, but before news had spread. New Orleans was not, however, the last place to receive news of peace. The British commander at Fort Michilimackinac, at the upper end of Lake Huron, received word of the Treaty of Ghent on 11 May 1815, nearly five months after the treaty had been signed, and a full two months after a letter containing the news had been dispatched.¹⁷ News was not the only thing that traveled slowly on the lakes, and as the British were not willing to leave Canada undefended, the Royal Navy was presented with a new mission, acting as a peacetime shipping organization and border patrol rather than a navy at war.

The navy took on this new role in peace, but met with the same challenges it had faced during the war. In 1814 W.H. Robinson, the Commissary General at Montreal, wrote on the subject:

The difficulties experienced in the transport of Stores and Provisions during the last Season for the construction, armament, and equipment of His Majesty's Ships on Lake Ontario, and for the Supply of the Troops in Upper Canada imperiously demand that means be promptly devised for a more certain conveyance of the innumerable Articles necessary for maintaining in that Province the great, and increasing, Naval and Military Force requisite for its defence [sic].¹⁸

This dearth of men and supplies was blamed for the Lake Erie squadron's failure in 1813; the loss of the fleet only exacerbated these problems.

The problem of transportation of stores was arguably greatest in Upper Canada, particularly in reaching Fort Michilimackinac; E.W.C.R. Owen determined to build a small number of transport vessels for service on the upper lakes. Before construction could begin, however, he was informed that the naval work Yeo had authorized at Penetanguishene ceased, owing to Drummond's removal of the military and commissary departments from Penetanguishene upon receiving news of the Treaty of Ghent. A desperate need for provisions prevented the shipwrights from continuing any work at the establishment. The road that was envisioned between Penetanguishene and York was impassable, preventing any shipment of supplies. The shipwrights therefore headed back to Kingston to receive instructions on how to proceed.¹⁹

Shortly after the shipwrights left Penetanguishene, E.W.C.R. Owen formed a new plan. Construction on Lake Huron was suspended, and two transport schooners would instead be constructed on Lake Erie for service on the upper lakes. The lateness of the season concerned the commodore. In a letter of 6 April 1815, Owen wrote, "I intend no longer to delay it, and will take immediate measures with the Commissioner for building on some convenient situation, a couple of sharp vessels."²⁰

A plan for the schooners (fig. 2) was drawn by Robert Moore,²¹ Assistant Shipwright at the Kingston yard, and he and a party of shipwrights and artificers – including those who had recently left Penetanguishene – departed for Lake Erie. The total number of workers at the Lake Erie shipyard eventually reached 76 shipwrights, 5 blacksmiths, 4 joiners and 12 sawyers.²²

With no extant shipyard on the lake, a suitable place had to be located before work could begin. Sites such as the entrance to the Grand River, which would provide access to timber growing along the lengthy river's shores, and Turkey Point, near the Long Point peninsula, were considered but rejected. Both sites were considered too distant from established storehouses and too exposed to Lake Erie.

The shipwrights eventually selected a site along the Niagara River, near the mouth of the Chippewa River. The entrance of the Chippewa was still blocked by the hulls of the two schooners scuttled there in 1814, and a bar at the mouth of this river cut down its depth to only five feet (1.52 m), which was far too shallow for the ships E.W.C.R. Owen and Moore intended. A nearby farm provided suitable land for a temporary shipyard. The property was part of the farm of Mr. I. Street, Jr.,²³ at the junction of the eponymous Street's Creek and the Niagara River (fig. 3). Street's farm was only nine miles (14.48 km) from Queenstown on Lake Ontario, enabling supplies to be sent without a lengthy and arduous overland journey. In addition, the bank of the river was firm, and there was adequate water in which to launch the ships when they were completed.

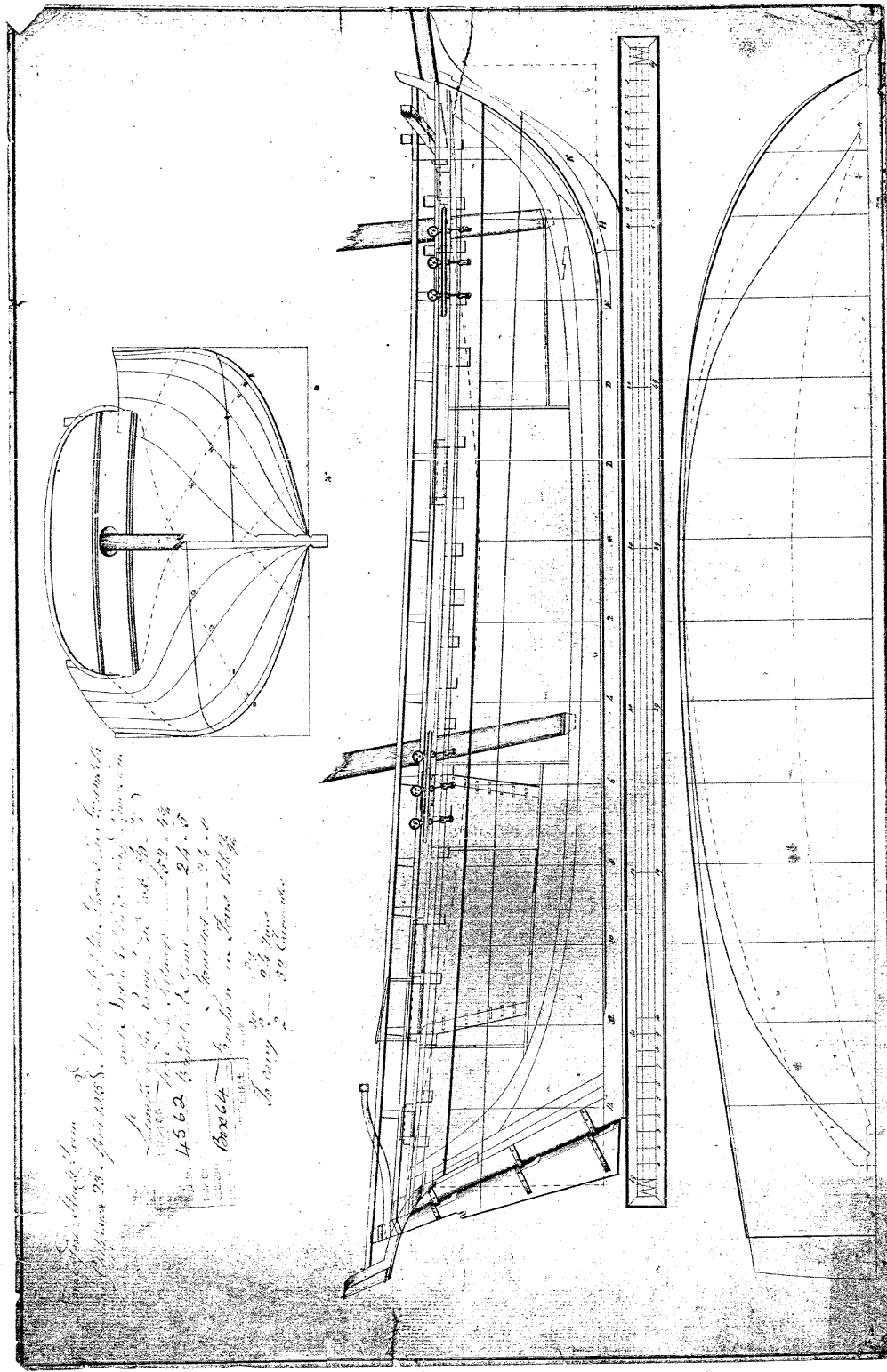

Figure 2: Draft of *Newash* and *Tecumseth*. (Public Record Office, Admiralty Fonds, ADM, Reg. No. 4562, Box 64.)

The proximity of the Street farm to the Chippewa River allowed shipwrights to work simultaneously on the schooners that were raised from the river and the two newschooners. Shipbuilding timber from the interior of the Niagara peninsula was floated down the Chippewa and transported to Street's Creek for construction.²⁴ A survey of the area noted that "good pines are found upon the River Chippewa"²⁵ while oak came from Navy Island²⁶ and forests near the heads of the Chippewa and Grand rivers. Naturally curved compass timber was preferable for ship construction, although straight-grained pieces were cut to shape as well. The Royal Navy had no stockpiles of shipbuilding timber on Lake Erie, and there was no time to allow the timber to season. The speed in which the schooners were constructed was dictated by the Royal Navy's immediate need for ships on the upper lakes.

The two small schooners were raised from the Chippewa River bottom, purchased for service in the Royal Navy, renamed *Huron* and *Sauk* and outfitted in the late spring and early summer.²⁷ They were put to immediate use transporting supplies on Lake Erie. For the new vessels, E.W.C.R. Owen specified "two stout vessels of about 130 tons each"²⁸ were to be built, though the ships would actually be slightly larger. He offered names for the ships: "I propose to name them *Tecumseth* and *Newash* from two friendly Indian Chiefs."²⁹ Tecumseth, also spelled Tecumseh, was a Shawnee warrior who resisted the encroachment of the United States into Indian lands. Later a British ally, he was killed in the Battle of Moraviantown in 1813. Newash was an Ojibway chief and a British ally as well.

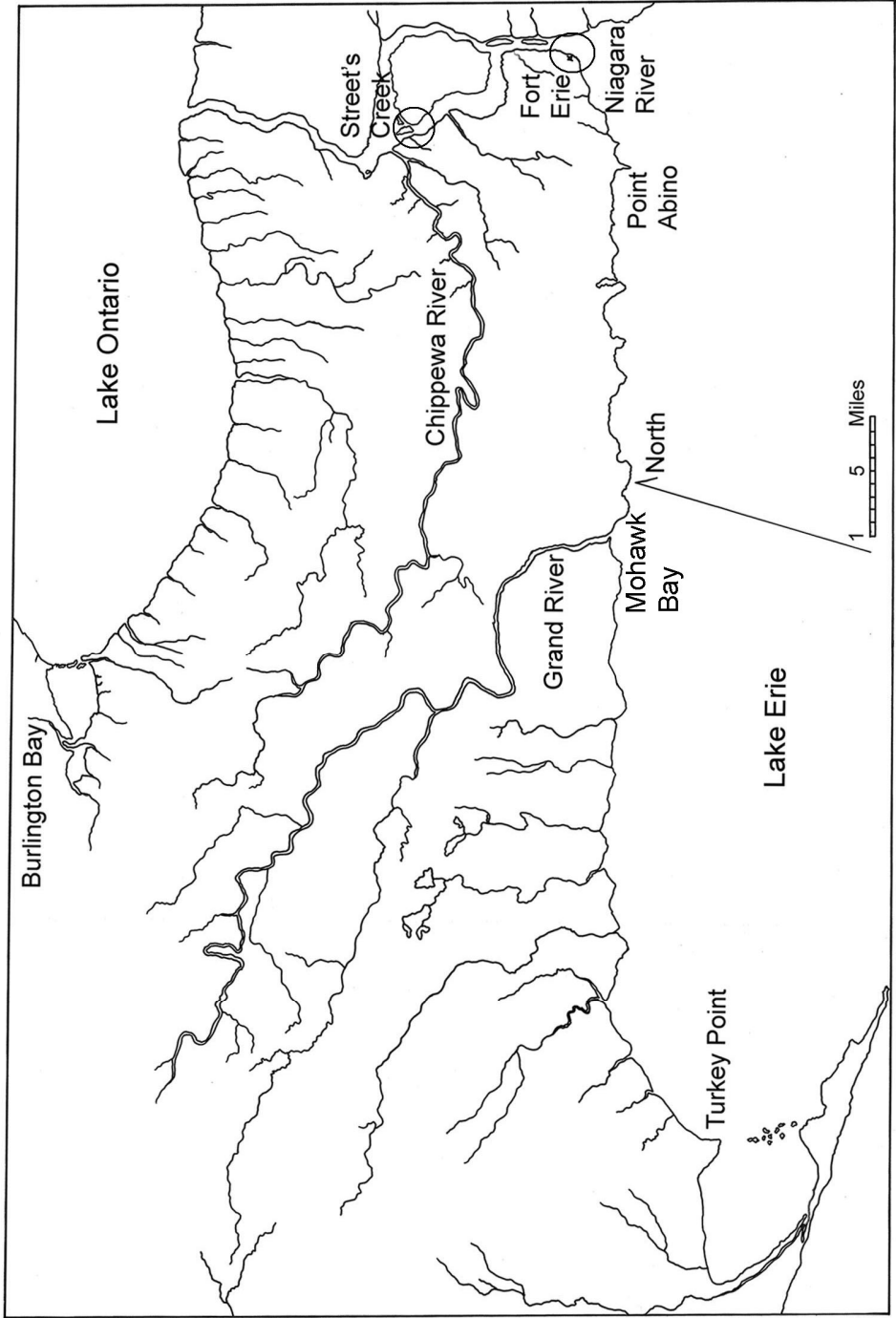

Figure 3: Map of the Niagara Peninsula. (Detail after William Wood, *Select British Documents of the Canadian War of 1812*, map #3.)

CHAPTER II

TWO SHARP SCHOONERS

Robert Moore's draft of the two schooners built at Street's Farm was made on 23 April 1815, as a plan for the ensuing construction. As drawn, the schooners were of 166 12/94 tons burthen, almost 25 percent larger than Commodore E.W.C.R. Owen's original order. The two schooners were envisioned "to be of considerable size and strength."³⁰ The draft shows they were 70 feet 6 inches (21.49 m) on deck, with an extreme breadth of 24 feet 5 inches (7.44 m).³¹ The ships drew 6 feet (1.83 m) of water forward and 9 feet (2.74 m) aft.³² The shallow draft was necessitated by the ships' employment on the inland lakes.

Commodore Owen specified that these be "a couple of sharp vessels."³³ Unlike most cargo ships of this period, which were designed to be capacious with round and full hulls, sharp vessels were designed to be nimble and sleek. The design of a sharp hull reduces drag caused by water by trimming the underwater portion. Wherever excess shape could be cut down, such as the bow, stern and bottom of the ship, the vessel's lines were reduced.³⁴

Moore's draft shows that the vessels were designed to have 12.5° of deadrise at the midships section, (fig. 4) with raked, or angled, stem and sternpost, and a low profile or sheer.³⁵ The vessels had the common codfish head/mackerel tail shape, with the widest points of the hulls forward of the midpoint of their lengths. This shape had been adopted

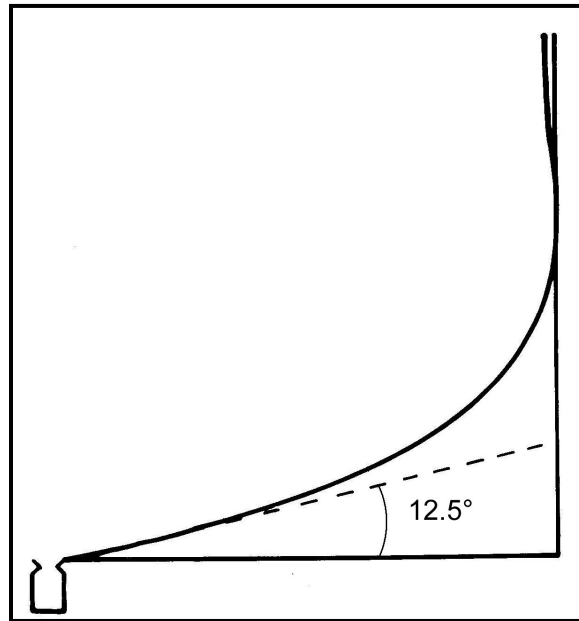

Figure 4: Angle of deadrise.

from the natural world, observed in fish with full heads and tapering bodies, which gave the hull form its name. The maximum breadth of the new schooners was located just 29 feet (8.84 m) aft of the stem, well forward of the midpoint of the overall length. In order to maintain ample cargo space in the midships hold, the middle of the ship remained full, while the hull was trimmed in the bow and stern. This reduction in the bow was helpful when sailing, as there was simply less boat to push through the water. Without the extra buoyancy provided by a capacious design, however, the bow would have plunged into oncoming waves as the ship pitched in a headsea, causing spindrift to spray over the decks.

The crew of the ship lived in the forward and aft ends of the ship. Two transverse bulkheads are shown in the draft, delineating the crew's quarters forward and a

wardroom or officers' quarters aft.³⁶ Traditionally, the bulk of the crew lived in an area in the bow of the ship once called the forecastle; this was subsequently shortened to fo'c's'le.³⁷ Sailors living in the fo'c's'le slept in canvas hammocks, while the officers living aft were treated to small bunks. The sole that served as the floor of the aft quarters was laid parallel to the waterline, while the sole of the fo'c's'le angled slightly upward at its forward end. Each of these compartments had 6 feet (1.83 m) of headroom.³⁸ Between them, the middle of the ship was left open, creating a space roughly 23 feet by 24 feet (7.01 m by 7.32 m), with a 9-foot (2.74 m) depth of hold.³⁹ In keeping with the purpose of the ships, the central hold of each was left open and uncluttered. At the waterline, the ship tapered significantly in the bow and stern, contributing to her sharpness but amidships, the vessels remained very full to maximize their capacity for carrying stores.

In addition to transporting stores, it was important that *Tecumseth* and *Newash* be capable of serving as warships in the event of future war with America. The schooners were designed to carry four guns apiece. The armament was to be two 24-pounder long guns and two 32-pounder carronades, all carried on the deck. Commissioner Hall recommended that the guns be placed in such a manner: "two long twenty-four [sic] pounders abaft the foremast to be used upon the bowers or as broadsides, as occasion may require, and two carronades abaft the mainmast for the broadsides or quarters."⁴⁰ (fig. 5) Two pivot guns (fig. 6) were placed on deck between the masts, and the carronades abaft the mainmast were placed on carriages. The original orders specified

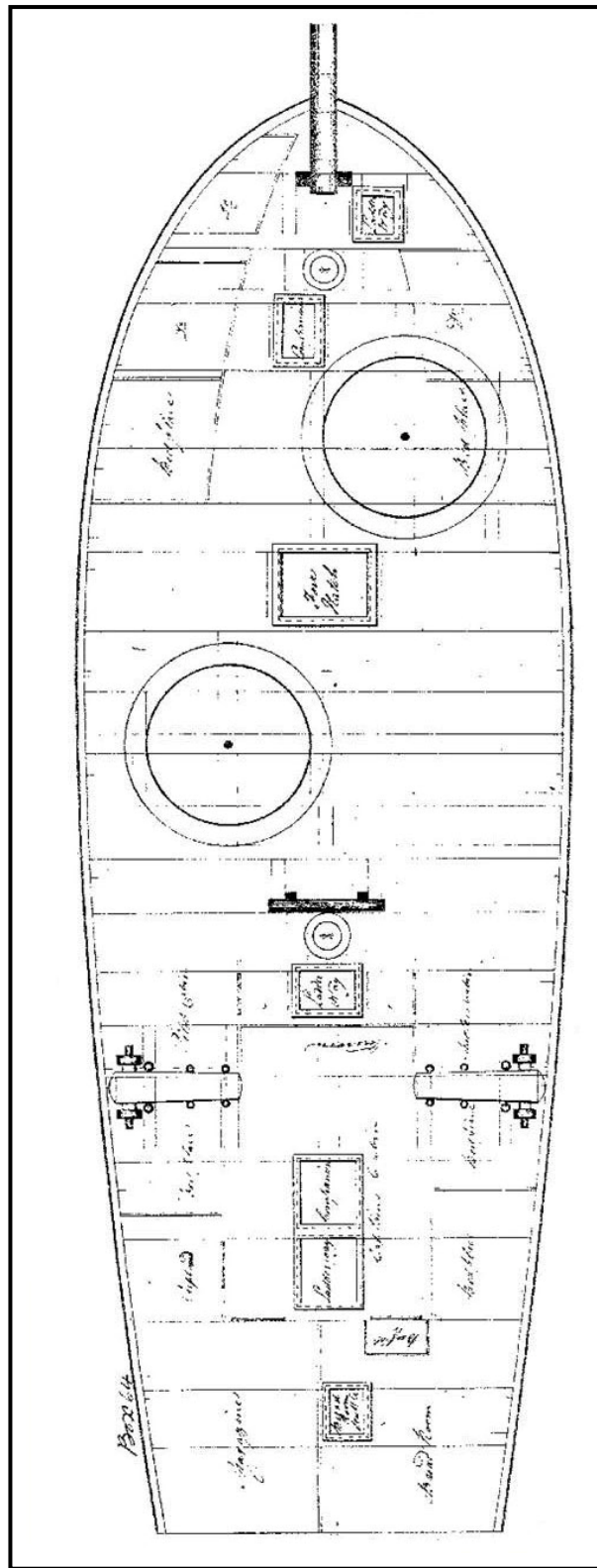

Figure 5: Deck layout, showing placement of pivot guns and carronades. (Public Record Office, Admiralty Fonds, ADM, Reg. No. 4562, Box 64.)

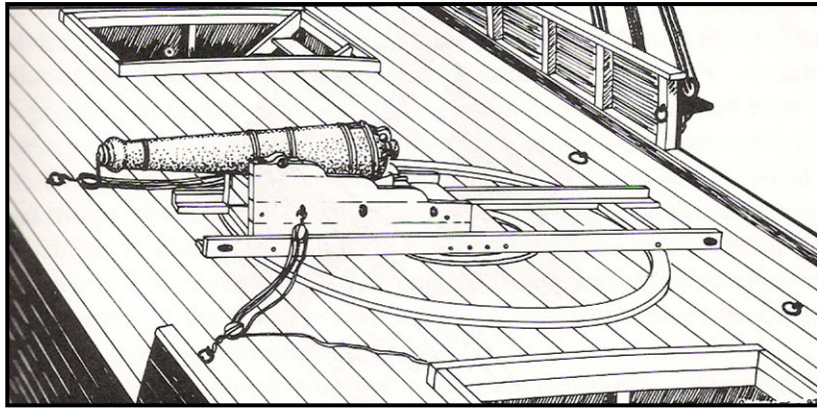

Figure 6: A pivot gun. (Reproduced with permission from Kevin J. Crisman, *The Eagle*, 7, fig. 3.)

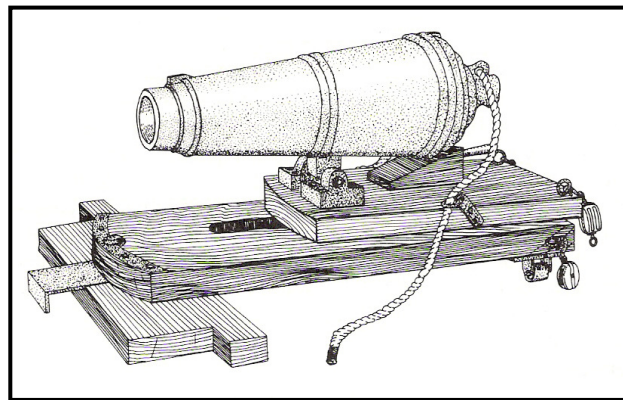

Figure 7: A carronade. (Reproduced with permission from Kevin J. Crisman, *The Eagle*, 22, fig. 10.)

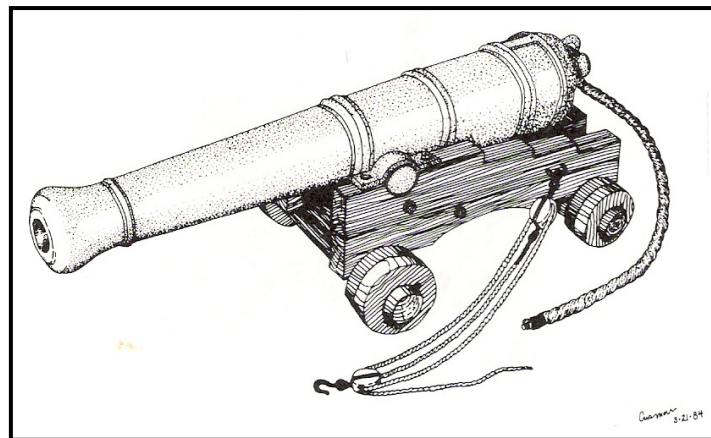

Figure 8: A long gun. (Reproduced with permission from Kevin J. Crisman, *The Eagle*, 22, fig. 11.)

that two 32-pounder carronades were to be installed, but the ships were laden with two 24-pounders apiece, in addition to the 24-pounder long guns.⁴¹ The change in armament meant that the ships carried only one size of shot, which may have eliminated confusion. First cast by the Carron Company of Scotland, carronades (fig. 7) were shorter and lighter than contemporary long guns (fig. 8), with shorter ranges. A 32-pounder carronade was 4 feet 0.25 inches long (1.23 m) while a 24-pounder carronade was 3 feet 7.50 inches long (1.11 m). In contrast, a 24-pounder long gun was 10 feet long (3.05 m). The thinner-walled barrels of the guns weighed far less than their long gun counterparts. A carronade weighed only 50 to 60 pounds (22.68 – 27.22 kg) per pound (0.45 kg) of shot it could throw, while the long gun had a proportion greater than 100-to-1. A 32-pounder carronade weighed 17cwt 0qtr 14lb (1918 lbs or 872 kg), a 24-pounder 13cwt (1456 lbs or 662 kg), and a 24-pounder long gun 52cwt (5824 lbs or 2647 kg).⁴²

The lighter weights of the carronades allowed them to be carried on ships with less strain on the hulls, and were less detrimental to stability than heavier guns. Reducing the carronades from 32-pounders to 24-pounders eliminated 462 pounds (210 kg) of deck weight per gun. Carronades also used less powder per shot. A 32-pounder carronade throwing a 32-pound (14.55 kg) shot used 4 pounds (1.82 kg) of powder; a 24-pounder used 3 pounds (1.36 kg), and a 24-pounder long gun used 8 pounds (3.64 kg) per shot. Carronades and long guns were often used in company with each other. Long guns allowed a vessel to stand off from an enemy, or engage them from a distance, while

carronades were employed at close range. At short ranges, the carronade could unleash a tremendous barrage of iron shot upon an enemy.

Unlike many of the larger ships of the War of 1812 period, the guns on the decks of *Tecumseth* and *Newash* fired over the rail, instead of protruding through gunports cut in the bulwarks of the ships. The rail remained low and was supported by stanchions. The decision to keep the rail low and open eliminated the task of assembling bulwarks for the vessels and reduced excess weight at the topsides of the hull. The stanchions and rail offered little protection to sailors working on deck, but the armament remained within sight, a visible reminder of the schooners' multiple purposes. Though they were intended as transports, *Tecumseth* and *Newash* were also envisioned and built to serve as warships. In a letter to Drummond, E.W.C.R. Owen stated that the schooners were to be "adapted to receiving guns and acting as Men of War at any time hereafter if it shall be necessary."⁴³ Hall echoed the sentiment, and demonstrated that this purpose was inherent in the design of the vessels. The schooners were "to be armed as gun vessels on emergency,"⁴⁴ but their primary duty was to transport stores. Captain William Bouchier, who was appointed to superintend the construction of the schooners,⁴⁵ was instructed that "such of the Guns as you think proper may be left on shore."⁴⁶

Newash and *Tecumseth* were to carry small arms as well. Owen instructed that "the Seamen are to be exercised and trained to the use of Small Arms, the same as the

Marines; one half of the Seamen of each Are to be armed with Muskets, and the rest with Cutlass, Pike and Pistol.”⁴⁷

Captain Bouchier was placed in charge of the Lake Erie establishment, which included the new schooners as well as *Huron* and *Sauk*. *Newash* and *Tecumseth* were placed under the commands of Lieutenants Thomas Bushby and Henry Kent, respectively.

Bushby joined the Royal Navy in May 1811, and passed the lieutenant’s exam on 16 August of that year. When the United States declared war on 18 June 1812, Bushby was sailing as a lieutenant in H.M.S. *Herald*, a 20-gun sixth rate. In 1814, he was transferred to H.M.S. *Prince Regent*, on Lake Ontario. Over the following year, Lieutenant Bushby served in His Majesty’s Ships *Prince Regent*, *St. Lawrence*, and *Montreal* on Lake Ontario before being transferred to Lake Erie.⁴⁸

Lieutenant Henry Kent, who would take command of H.M. Schooner *Tecumseth*, had already had a more colorful career. Kent joined the Royal Navy as a midshipman in 1807. After sailing in several vessels, he obtained the rank of lieutenant in March 1811, while sailing in H.M.S. *La Fantome* on the Atlantic.⁴⁹ In January 1814, 217 crew members from *La Fantome*, as well as H.M. Ships *Arab*, *Manly* and *Thistle* left the Atlantic squadron for Kingston, where the need for men had become dire. Lieutenant Kent was among those sent to the Great Lakes. After departing their ships in Saint John, New Brunswick, amidst cheers and celebration, the men were ferried in sleighs 80 miles

(128.72 km) to Fredericton. For the rest of the nearly 900-mile (1448.1 km) journey to Kingston, the men walked with snowshoes and trailed toboggans of provisions. One hundred ninety-one men arrived on 21 and 22 March 1814, and fourteen stragglers followed a few days later.⁵⁰ Upon arrival in Kingston, Kent was appointed first lieutenant in H.M.S. *Princess Charlotte*, and commanded her in an attack on the American fortification at Oswego in May 1814. Lieutenant Kent remained on Lake Ontario, commanding a flotilla of gunboats,⁵¹ until he was transferred to Lake Erie as construction began on the new schooners.

The keels of *Newash* and *Tecumseth* were laid in the middle of May 1815. A forward-curving stem and aft-raking sternpost were laid at either end of each keel, defining the vessels' lengths. Raising frames along the spine of the keel formed the skeletons of the ships; each frame was comprised of multiple pieces, called floors and futtocks (foot hooks). Individual planks were laid beside each other and attached to the frames along the length of the vessel to form the schooners' skins. Wherever the hulls' curves became complex, the planks had to be bent into place. Inside the hull, interior, or ceiling, planking provided protection for stores and presented a solid surface to stand on. Deck beams stretched between frames across the width of the ships, and the decks were planked above the holds.

Two rudders were made, one for each vessel, and hung on the sternposts with pintles and gudgeons. A tiller controlled each rudder, steering the ship. Tillers were basic steering

gear, which were easily constructed at the temporary shipyard, and could be readily replaced if they became damaged.

The timber for the schooners was supplied from the forests surrounding the Chippewa and Niagara rivers. The wilderness location of the temporary shipyard meant that some supplies had to be shipped from other shipyards. In July, Edward Laws, storekeeper at Kingston, wrote to James Walker, Deputy Storekeeper at Montreal, to request additional building materials for the new schooners. Montreal was capable of supplying much of the ironwork needed for the ships' fittings. Laws' request included boat nails, door hinges, metal hinges for the magazine, reaming irons and iron rings. He also mentioned that "Flat and Round Iron [stock] of each size are much wanted."⁵²

Much like the ironwork that was shipped to Street's Creek, sails for the schooners were also made elsewhere. Some of the larger shipyards in His Majesty's service employed sailmakers, riggers, rigging laborers, shipwrights, mastmakers, and top and capstan makers,⁵³ but the facilities at Street's Creek were never very elaborate, and did not include this variety of workers. The shipwrights and crew who arrived at Lake Erie may have filled multiple roles, and made do with what was available. Despite the distance from larger, better-equipped shipyards, there is no indication that construction was delayed for want of any supplies.

Before the ships could be launched, ways had to be constructed to allow the hulls to slide safely into the water. Once these were complete, the empty hulls were ready to leave the stocks. The interiors of the hulls were whitewashed, and the exteriors were painted black and yellow above the waterline. *Newash* and *Tecumseth* were launched into 12 feet (3.66 m) of water⁵⁴ on 13 August 1815⁵⁵ (fig. 9). The schooners were launched without any armament, and without their sailing rigs. *Tecumseth*'s lower masts were swayed the following day, and the bowsprit was in place on 15 August,⁵⁶ with *Newash* raising all three on 15 August as well.⁵⁷

As the schooners neared completion, Commodore E.W.C.R. Owen visited the shipyard at Street's Creek and observed their hulls. Presumably he was satisfied with the vessels and the skills of their shipwright. In September 1815 the Master Shipwright at Kingston, Thomas Strickland, was killed in a fall from his horse and Robert Moore was appointed to succeed him.⁵⁸

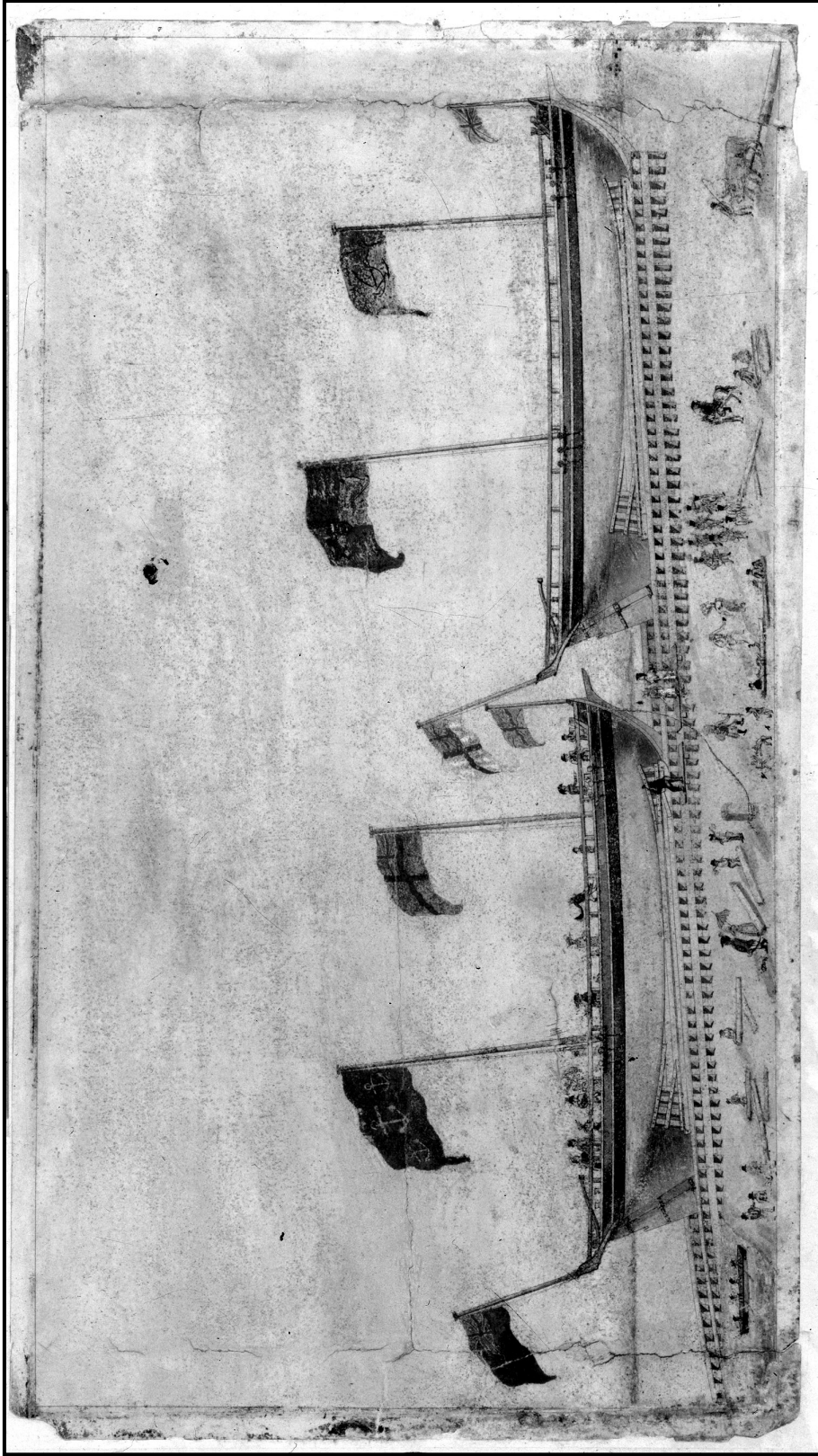

Figure 9: "The Dual Launching of the *Newwash* and the *Tecumseth*." (Reproduced with permission of the Royal Ontario Museum. ©ROM.)

CHAPTER III

MASTING AND DISMASTING

Tecumseth and *Newash* were rigged as schooners, a popular rig on the Great Lakes at the time. Schooners⁵⁹ are two-masted vessels with fore-and-aft sails on both masts, although square sails can also be carried. The combination of fore-and-aft and square sails provided a measure of flexibility in the schooners' sail plans. The versatility of the rig made it appropriate for a variety of wind conditions, which was essential when sailing on the Great Lakes. As launched, *Newash* and *Tecumseth* had identical rigs, with fore-and-aft fore and main sails, and square topsails and topgallants above on each mast. The masts were each a two-part assembly, with a lower mast and a topmast, which included a topgallant pole. A bowsprit and jibboom projected from the front of the each schooner.

The lower masts were put in place with the aid of sheers, which were used like a tripod to step the masts (fig. 10). The lower masts were secured and supported by standing rigging, consisting of stays, which led forward, and shrouds, which led to the sides of the ship. The schooners also carried runners, consisting of a pendant that ran from the shoulders of the mast, or hounds, to a block-and-tackle assembly that could be attached to the deck.⁶⁰ Maintaining proper rig tension was important in securing and stabilizing the masts, which in turn supported the sails and drew the whole fabric of the ship together to form a singular entity. Tension on the stays prevented the masts from toppling over backwards in heavy seas or storms. Lines called runners led aft,

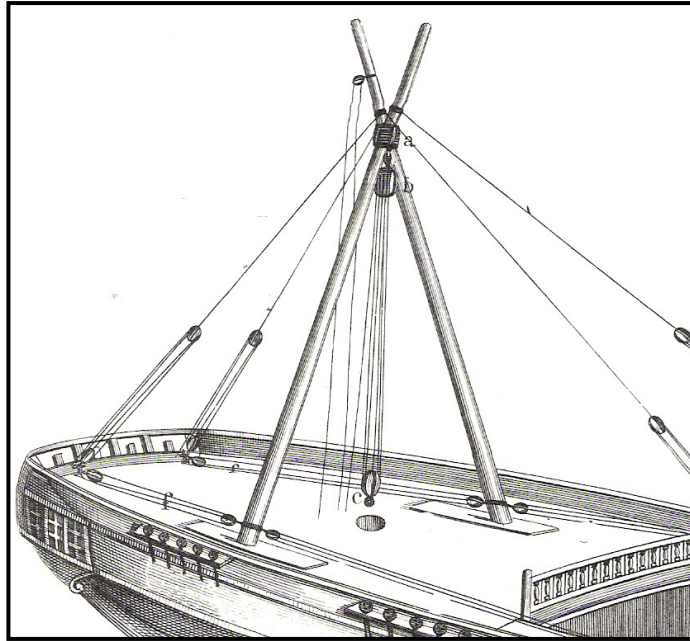

Figure 10: Stepping masts with sheers. (Detail after Darcy Lever, 17, fig. 144.)

supporting the masts against forward pressure from behind. There were three shrouds on each side of the lower masts, which acted to restrain the mast from falling to either side. The tautness of the shrouds transferred the load of the full sails to the hull of the ship. The deck stiffened the open end of the “U” or “V” shape of the ship’s hull, preventing the sides of the ship from caving in. Once the top hamper was raised into place, the top and topgallant masts and jibboom were also secured with standing rigging. Once again forward-leading stays⁶¹ were rigged. Shrouds were set up on either side of the masts, though for top and topgallant masts the shrouds were fixed to the rigging of the mast below, rather than running all the way to the sides of the hull. Additional strength was provided by backstays, which opposed forward-leading stays and did run all the way to the sides of the ship. In the front of the vessel, the bowsprit and jibboom were secured

in a very similar manner as the masts, although on a level closer to horizontal than vertical.

In addition to securing the masts individually, the standing rigging also acted to unite the various parts of the rig. The fore lower mast stays led to the bowsprit, and the bowsprit was connected to the stem with bobstays. The fore topmast stays ran to the bowsprit and jibboom, and the main topmast stays ran to the fore lower mast. The whole rig was drawn together with the standing rigging. The actual tensioning of the rig was an art that allowed all the individual pieces to function as one unit, without any piece bearing too much of the load. Too much strain on the shrouds could press the hull against the deck, squeezing the caulking out from between deck planks. Too little strain on the shrouds and stays and the masts would move unnecessarily, increasing pressure on the mast partners or maststeps. A loose rig that suddenly came under strain could shockload the lines, straining them beyond their breaking strengths and potentially causing damage to the ship and her crew.

Newash and *Tecumseth*'s rigging was made of fiber rope. The fore shrouds alone were made from 1.50-inch (3.81 cm) diameter rope. Higher in the rigging, smaller diameter cordage was used, since the top and topgallant masts were much smaller in size than the lower masts and the necessary tension was distributed over a longer run of rope. The thick ropes formed a supporting network for the masts, but they served another purpose as well. Whenever any work had to be done aloft, sailors used the stiff spiderweb

created by the standing rigging as a series of ladders. Horizontal “rungs” called ratlines were created by tying lines between the shrouds. By using ratlines and shrouds, a sailor could climb aloft to furl or unfurl sails. As a ship heeled over in a breeze, the shrouds to the weather side of the ship, closer to the wind, became slightly tighter than those on the leeward side – the side further away from the wind. These “weather shrouds” were the choice of any seaman who had to climb aloft into the rig while the ship was underway. Not only were the shrouds slightly tighter, but the wind blew the sailors towards the shrouds, rather than away from them, and as the ship heeled the weather shrouds provided a more comfortable angle for sailors to climb.

Newash and *Tecumseth* were each set up with hemp rigging. As the rig was tensioned, the hemp fibers stretched. If the rig stretched too much, it would need to be tensioned again. Shortly after *Newash* was launched, the lower rig was used in an attempt to heave her down. This was done to remove a cleat, probably used to attach a supporting structure before the launch, which remained on *Newash*'s bottom.⁶² Shipwrights were concerned that the cleat would hamper the vessel under sail. To heave the schooner down, purchase blocks were attached at the heads of the fore and main lower masts, and lines were run through the blocks and secured to an anchoring point, probably on shore. Hauling on these lines caused the vessel to careen over to one side, exposing her bottom. The new standing rig had stretched and was slack, however, and the load of the ship fell upon the masts themselves. The masts began to give way.⁶³ The vessel was quickly

righted, the blocks removed from the mastheads, and *Newash's* rigging was set up afresh. The cleat remained on the bottom of the hull.

By 25 August 1815, both schooners had swayed and crossed all the masts, yards, gaffs and booms and bent their sails on. The sails were attached to yards and gaffs or parts of the standing rigging. Other hemp lines led down to the deck, which set the sails, controlled their attitude, or hauled them down. These lines formed the running rigging, which allowed the sailors to do a majority of the work of sailing from the safety of the deck. The full complement of sails for each schooner consisted of a flying jib, standing jib, gaff foresail, square-rigged foresail, fore topsail, fore topgallant sail, boom mainsail, main topsail and main topgallant sail.⁶⁴ When they arrived at the temporary shipyard, Captain Bouchier discovered that the sails provided for *Newash* and *Tecumseth* were disproportionate to the sizes of their masts, so “as to be absolutely useless.”⁶⁵ With no sailmaker on Lake Erie, new sails would have to be made at Montreal and sent west.

Disproportionate sails can be problematic when sailing. A sail that was too large could not be tensioned by the existing masts and yards. Without proper tension at the head and edges of a sail, a proper shape cannot be achieved, and the sails will not attain their full driving force. An undersized sail provided less sail area than the spars permitted, but a small sail could still be stretched to the proper tension. It is not known whether the schooners' sails were too large or too small.

Even without proper sails, the vessels prepared to get underway. On their first passage, *Newash* and *Tecumseth* each carried shipwrights and officers, as well as dockyard stores and provisions. The voyage would take the ships both to Fort Erie, at the junction of the Niagara River and Lake Erie, and Grand River. The latter was to become the home of the new naval establishment on the lake. Before departing, the vessels received their first installment of provisions for shipboard life. Onboard *Newash*, the crew loaded 3097 pounds (1407.73 kg) of bread, 40 gallons (151.20 l) of rum, 572 pounds (260.00 kg) of beef, 318 pounds (144.55 kg) of pork, 28 pounds (12.73 kg) of raisins, 155 pounds (70.45 kg) of butter, 325 pounds (147.73 kg) of sugar, 313 pounds (145.27 kg) of cheese, and 37 pounds (16.82 kg) of fresh beef.⁶⁶ These basic provisions were occasionally augmented with others, such as chocolate, coffee, tobacco or juice.⁶⁷

On the morning of 26 August 1815, the two schooners made sail and left the Street's Creek yard together. The passage up Niagara River was difficult. The schooners could only sail against the current when winds were favorable. When the wind shifted they dropped their anchors and waited for an agreeable breeze. *Tecumseth* was the first to anchor off Fort Erie, after running through the rapids at Black Rock on 30 August 1815.⁶⁸ A logbook kept onboard *Tecumseth* notes that the current at Black Rock was running at 7 knots (8.06 mph).⁶⁹ *Newash* remained stuck below the rapids a while longer, running through the next day. At Fort Erie the schooners received more provisions, as well as iron shot for guns, to carry to Grand River.

The vessels stood off and onshore as they made their way from Fort Erie towards Grand River. In the early morning hours of 2 September, the skies were cloudy with fresh breezes from the south-southwest, veering to the southwest,⁷⁰ and the new ships were still making sea trials. The sails and rigging were new, and the run up the Niagara River had not given much opportunity for the lieutenants to experiment with different sail combinations and become familiar with the quirks of their particular schooners. The vessels stood off into the lake to have more sea room around them. At 6:30 a.m., Lieutenant Bushby observed that conditions had become “squally.”⁷¹ Captain Bouchier, sailing in *Newash*, made this observation: “*Tecumseth* some distance astern her rigging being perfectly new had stretched considerably.”⁷² James Childs, Second Master⁷³ sailing in *Tecumseth*, recorded these events:

A.M. Fresh Breezes and Cloudy weather at 1 Double Reefed the Topsail at 730 [a.m.] in stays with fore Sail Brailed up, on Coming head to Wind she Dipped the Bowsprit [sic] under and carried it away Close to the Gammoning lowered the Mainsail but before she Could pay off to get her before the wind Both Masts went by the Board Let go the Best Bower in 9 fathoms [54 feet or 16.46 m] A heavy swell setting all hands employed Clearing the wreck.⁷⁴

The physics of the dismasting are evident from Childs’ account. According to the Beaufort Scale of Wind Force, “Fresh Breezes,” also known as Beaufort Force 5 on a scale of 1 to 12, can range from 16 to 21 knots (18.41 to 24.17 mph) with a mean wind speed of 19 knots (21.87 mph). Under these wind conditions, seas are predicted to reach

up to 6.6 feet (2.01 m). Even with gusts⁷⁵ approaching 30 knots (34.52 mph), these were not particularly hazardous conditions. Childs' weather observations were made at or around midnight, however. The wind and seas presumably continued to build throughout the morning hours, reaching a "heavy swell" after daylight.

With winds blowing from the south-southwest, the schooner could not sail directly into the wind, but instead had to tack back and forth, alternately standing in towards shore and off into the lake, to make any headway up the lake. Though the sail configuration at the time of the dismasting was not recorded, it is evident that the mainsail was set, and the loose-footed foresail had been brailed up, or taken in, at some point previous. Childs did not record whether any headsails were carried at the time, but something must have been set in the forward part of the ship, to balance the mainsail. To sail properly, a vessel must balance sails along her length. The hull pivots about a balance point, usually found near the center of the ship. Sails that are set aft of this balance point will cause the ship to turn into the wind, like a weathervane. Sails forward of this point have the opposite effect, allowing a vessel's head to be blown away from the wind. Either of these motions can be compensated for, to a certain extent, by the angle of the rudder. The rudder has a limited effect, however, and it is always better to attempt a balanced sail plan. Any effective sail configuration would balance the sail area by having similar amounts forward and aft of the balance point.

The same principles are used to turn a ship. Manipulation of the center of effort of the sails can be used to thrust a ship into the eye of the wind. If enough momentum is carried, the ship can pass through the wind, and end up with the wind on the other side of the vessel. This is called tacking, and is often employed when a vessel is faced with an unfavorable breeze. A ship cannot sail directly into the wind, nor can it afford to sit at anchor until only the favorable breezes come along. When faced with an unfavorable breeze, a ship can sail as close to the wind, or as high, as possible with the wind on her port side, then turn and sail as high as possible with the wind on the starboard side. This is called “beating to weather.” When beating to weather, the ship covers a small amount of ground in the desired direction, though it sails a long, zigzag path. The turn at the end of each zigzag is made by either tacking or wearing. Unlike tacking, where the vessel is pointed into the wind, wearing is accomplished by turning away from the wind. Tacking is arguably the more difficult maneuver, since it requires precise manipulation of the sails. Wearing is a more forgiving maneuver, but ground is lost when the vessel turns away from the wind and crosses her own former path. Tacking may be more efficient, but it is also a more delicate maneuver, and cannot be performed in all circumstances.

Childs’ described the schooner as being “in stays” at the outset of the events. The schooner had begun to tack, and she was rounding up into the wind. A ship is particularly vulnerable as her bow begins to point into the wind. Here, the sails are no longer filled with wind and acting to drive the ship. The forward momentum of the ship

is lost, and she may end up going backwards, a dangerous position for the rudder. The position of the ship when caught head to wind is called being “in irons” or “in stays.”

Second Master Childs noted that “on Coming head to Wind she Dipped the Bowsprit [sic].” As the schooner turned into the wind, the swell, which had been building all morning, overcame the low-lying bowsprit and jibboom. The headrig essentially acted like the blade of a shovel, thrust under the surface of the water as the ship pitched. As the ship rose back up, the headrig was weighed down with water. If either of the headsails were not set at the time, the folds of the canvas might have filled with water, adding more weight which was harder to shake off. As Captain Bouchier had noted earlier, the hemp rigging had stretched after its initial tensioning, causing it to lie slack. Without the standing rigging to support it and transfer the load to the other parts of the ship, the bowsprit and jibboom carried all the weight of the water itself. Consequently, the bowsprit broke off close to the stem.

With the mainsail still set and acting like the tail of a weathervane, the vessel remained caught with her head to the wind. *Tecumseth's* crew hurried to get the mainsail down, to allow the vessel to fall off before the wind, to decrease the pressure of the wind on the spars and rigging. Childs indicated that the mainsail was lowered, but that the ship did not pay off quickly enough. With the vessel still pointed directly into the wind, the force pressed against the masts and yards. The foremast stays had carried away with the bowsprit, and there was little to prevent the masts from falling backwards. The speed in

which everything happened is evident from the scene recorded by Lieutenant Bushby onboard *Newash*; he seems to have watched a singular event: “at 7 [a.m.] observed The *Tecumseth*’s Masts and Bowsprit go over the side.”⁷⁶

The schooner had completely dismasted. Remarkably, no one was injured, and the schooner sat at anchor off Point Abino, recovering what gear could be dragged out of the water and hauled back onboard. *Newash* sailed down and anchored near her sister ship for a time, as the weather continued to deteriorate. “A heavy swell from the SW [southwest]” caused *Newash* “to pitch so violently as to render it Impossible to lay at anchor without Carrying away our Masts.”⁷⁷ *Newash* consequently weighed anchor and made sail, reaching back towards shore. Later that day, *Newash*’s crew found her fore lower mast sprung below the mast partners, just under the deck. The mast was woolded, or splinted, for security and the vessel continued towards Grand River. *Tecumseth* was a different story. The crew spent most of the afternoon wrestling sails and spars out of the water. “At 3 [pm] got all the Wreck in with the running Rigging excepting the Main Topsail.” Fortunately, she was carrying 36 shipwrights to Grand River, and the crew and shipwrights formed and rigged jury masts from the wreckage and made their way back to Street’s Creek.

New masts were cut at Black Rock, near the junction of the Niagara River and Lake Erie, and transported to Street’s Creek. The new main lower mast was stepped on 11 September 1815 and the bowsprit was raised the same day. The fore lower mast,

topmasts and jibboom followed, and *Tecumseth* set sail up the river again on 17 September 1815. A good portion of the salvaged rigging, both standing and running, must have been reused. Once again, the schooner worked her way out of the Niagara River, reaching Lake Erie a few days later.

While *Tecumseth* was being remasted at Street's Creek, *Newash* carried on to Grand River and attended to her own rigging. The fore lower mast was sprung just below the partners, near deck level. Though the damage had been woolded when it was discovered, the repair job did not hold. Upon reaching Grand River, the mast was removed, 6 feet 6 inches (1.98 m) was cut from the bottom,⁷⁸ and it was stepped again. Once the mast was repaired, the schooner continued on from Grand River to ferry provisions between military posts.

CHAPTER IV

LIFE ABOARD THE SCHOONERS

The complement of *Newash* and *Tecumseth* was 30 men for each schooner. Twenty of the men were seamen, including the lieutenants and warrant officers. E.W.C.R. Owen's instructions allotted the vessels the same number of officers and petty officers as a schooner of 40 men. There were seven Royal Marines, including a sergeant, and three ship's boys on each vessel.⁷⁹

Some of the men may have originally come from England, like Lieutenants Henry Kemp and Thomas Bushby. Often, those who had been serving before or during the war were eager to return to England. With the hope of retaining fresh men and proper morale in the fleet, Commodore Owen recruited volunteers "from among the Canadian Inhabitants themselves."⁸⁰

The hardships of life on a Royal Navy vessel were magnified on the upper lakes. Even the peacetime crew of 30 was large for *Newash* and *Tecumseth*. Most of the crew were housed in the fo'c's'le of the ship. There was little elbowroom in these cramped confines. The 6 feet (1.83 m) of headroom was only available when the area was not crowded with sleeping men in slung hammocks.⁸¹ Hammocks were provided by the Royal Navy, as was some clothing. Men took advantage of fresh water in the lakes to wash clothing and hammocks when necessary.⁸² Rainwater was also used for washing clothes or bathing.⁸³

Even with sporadic cleaning, the vessels and their crews were not always in the most attractive shape. To save money, the Navy Office ordered that ships were only to be caulked and painted once annually, unless absolutely necessary.⁸⁴ There were fewer requirements on the men's hygiene, and the fo'c's'le must have bordered on atrocious at times.

Only a small amount of light illuminated the below decks area, coming from open hatches, lanterns and small deck prisms, or "skylights."⁸⁵ In addition to being cramped and dark, the below decks area was often hot. A stove in the galley⁸⁶ provided hot meals and smothering conditions. In the cooler parts of the year, this might have been a welcome addition to the ships' equipment, but it was stifling in the summer. With at least part of the area below the waterline of the vessel, there was little ventilation to offset the heat.

A crewmember might attempt to escape the heat by spending his off hours on the deck of the ship. Depending on the hour, the decks might be solemn and peaceful or raucous and rowdy. The duality of life on a ship could be particularly maddening. The watch that one spent most of their time with could become as close as family, or could swiftly turn into one's worst enemy. The slow roll of a ship rocked by seas could be soothing, but it might also throw a sailor off balance or even over the side. The low rails of *Tecumseth* and *Newash* offered little to keep a man from sliding off the deck. The rig and sails dictated the schooners' potential courses and speeds. A squeaking gaff against

a mast might be a familiar, even welcome, sound, but it could also keep the crew awake at night. The view of the horizon from the yardarm could be stunning and spectacular, but a glance to the decks below might terrify. The very ships themselves may have been an escape for those who volunteered for various reasons, yet they might have quickly turned into virtual prisons for those men. Some sailors became career navy men, sailing all over the world and into old age, like Commodore E.W.C.R. Owen or Captain Bouchier. Others deserted, absconding with whatever they could and leaving the ships behind.

As a preventative measure, naval crews were often kept as many as six months in arrears. Pay for the months up to 30 September 1815 was not received until 23 December 1815.⁸⁷ Later, in 1816, Second Master Childs recorded that *Tecumseth's* crew was not paid through 31 December 1815 until 13 June 1816.⁸⁸ Artificers working in Upper Canada were paid slightly more because “the duties on the Upper Lakes are attended with more personal Inconvenience.”⁸⁹ To limit their exposure to these difficulties, E.W.C.R. Owen recommended that the men be rotated in September of each year, only serving on Lakes Erie and Huron for two years.⁹⁰ The army's soldiers in Upper Canada had been offered additional compensation, in the form of land grants. Shortly after the end of the war of 1812, sailors in the Royal Navy demanded similar compensation.⁹¹ In return for three years of service, Britain offered 100 acres of land in what would become the province of Ontario.

Until they could settle in the country, the navy provided for the men. Provisions were periodically loaded on the vessels; shipments might contain fresh and salt meats, flour, rice, raisins, chocolate, butter, cheese and wine.⁹² Rum was carried on board and rationed to the men, as well as tobacco, which was passed out to the crew on Sundays.⁹³ Strict accounting and rationing of provisions was necessary. While in charge of the establishment on Lake Ontario, Captain W.F.W. Owen gave specific orders for the men's meals. "[U]nder my orders...serve them a Hot meal every day during the Winter...on Sundays the usual allowance of Salt Pork with Pease [sic] – And on every weekday a [sic] Eleven-Twelfths of a pound of Fresh Beef for every Man of which to make their broth daily."⁹⁴

The provisions were not always the best quality. W.F.W. Owen recorded that the casks of salt meats were often without pickle and short on contents upon arrival in Upper Canada.⁹⁵ Fresh fruits and vegetables were often in short supply as well, in spite of the proximity of land. During the winter of 1815 – 1816, the Lake Huron fleet suffered from a lack of produce. No vegetables would grow in the sandy soil near the establishment, and the river water was said to be impregnated with petroleum.⁹⁶

Winters were particularly hard on the men. With transportation limited both on and offshore, the lake establishments were seasonally isolated. The men suffered from sicknesses such as fevers, pneumonic inflammation, ulcers, frost bite, dysentery and scurvy.⁹⁷

Even though the ships did not sail during the winters, there was still work to be done. With the holds empty, they could be thoroughly cleaned and whitewashed.⁹⁸ Repairs were made to the sails and rigging. During the winter of 1815 – 1816, several of *Newash* and *Tecumseth*'s sails were altered. Wood was cut and stockpiled for later use. Shipwrights and carpenters repaired and replaced the ships' equipment. *Tecumseth* added a belfry in the spring of 1816, to house a bell for signaling the change of watches for the crew.⁹⁹

Each watch usually worked a four-hour shift that was timed by an hourglass. *Newash*'s rigging warrant specified that the vessel carry 15-second, 30-second, and 30-minute glasses.¹⁰⁰ The half-hour glass was used to keep time during watch with the bell struck each time the glass was turned. At the end of the first half-hour, the bell rang once. At the end of the second half-hour, it was struck twice, and another stroke was added for each half-hour throughout the four-hour watch. When eight bells rang, the crew on deck knew it was time to be relieved, even if they had no means of telling time.

The 15- and 30-second glasses were used to gauge the vessel's speed. A long log line was prepared, of small diameter rope. A "chip" was placed at one end of the line, and the other was wound onto a spool. The chip was a triangular piece of wood, tied to the log line at two corners. At the third corner, a peg, which was also attached to the log line, could be inserted or removed. When the peg was inserted and the chip dropped into the water, it fell vertically and gave some resistance to the water. If the log line was

allowed to pay out, the chip remained relatively still in the water as the ship sailed away from it. The log line had knots tied every 25 feet (7.62 m) along its length.¹⁰¹ As the schooner sailed away from the chip, the log line paid out through a sailor's hand. By counting the knots for 15 or 30 seconds,¹⁰² he could determine the speed of the vessel through the water. After the sand in the glass had run out, a swift tug on the log line dislodged the peg in the chip, and it could be hauled back on board.

Like many things used on board a ship, particularly those used over the side, log lines had a tendency to disappear. Lieutenant Bushby's account of a six-month supply of stores includes one of each size hourglass, but eight log lines.¹⁰³ Bushby also listed four hand lead lines, which were used for measuring depths of water up to 20 fathoms (120 feet or 36.59 m), and one deepsea lead line. A lead weight was placed on the end of each of these lines, and marks were made along the line, corresponding to fathoms. The weight was tossed over the side and a man read the marks to determine the depth of water. A hollow at the base of the lead held a small amount of tallow; the stickiness of the tallow brought up a sample of the bottom. The weight on a deepsea line was heavier, and the rope much longer, than a hand lead.

Bushby also ordered other supplies that were used around the decks. The needs of the ships left little, if any, free time for the crew. Sails, for example, were regularly set and struck, and wear and tear took its toll on their fabric after time. The schooners stockpiled extra canvas for sail repair, as well as twine, needles and tallow. The standing and

running rigging, too, needed constant attention and maintenance. Extra tallow, oil, varnish, paint, turpentine, thimbles, tackle hooks and blocks were kept on hand for replacement of worn or damaged items and in case of emergency.¹⁰⁴

The ships' work also required the crews to load and unload provisions and cargo. Some of the unusual cargo required imaginative stowing arrangements. On at least one occasion, the schooners carried wheelbarrows,¹⁰⁵ two 8-inch (20.32 cm) iron mortars¹⁰⁶ and a large case containing "rope machinery."¹⁰⁷ In between loads, the holds were swept and occasionally whitewashed. Keeping the ships properly balanced with the differing weights of cargo meant shifting stone¹⁰⁸ and iron ballast¹⁰⁹ in the bilges. The passengers carried in the schooners were eclectic as well. Shipwrights, soldiers, a bishop,¹¹⁰ and even several children¹¹¹ were brought on board for short voyages.

Passages up and down the lakes brought their own workload. Hands were employed watching for other vessels and steering. Most or all of the crew was needed to hoist sails and weigh anchor. *Tecumseth* and *Newash* each carried a "best bower" and "small bower" anchor in the bows. The best bower was the heavier of the two, weighing 8 cwt 2 qrs 0 lbs (952 lbs or 432.73 kg); the small bower weighed 7 cwt 0 qrs 0 lbs (784 lbs or 356.36 kg).¹¹² The heavier anchors were secured with hemp cables, slightly less than 2 inches (5.08 cm) in diameter. With nearly thirty men available to haul on the cable, a majority of the work of weighing anchor could have been done by hand. A handy billy,

a tackle providing purchase, or a windlass was employed when necessary, to lighten the men's load.

A windlass is often considered a vital part of a vessel's equipment, but it is conspicuously absent from Robert Moore's draft of the hulls. This may have been a simple omission on Moore's part, since Second Master Childs' logbook verifies the presence of a windlass.¹¹³ The logbook only contains one reference to the windlass, however, which may indicate that the windlass was only rarely employed. It is possible that the 30-man crew, large by the vessel's standards, had enough strength among its ranks to perform most of the lifting required in regular circumstances,¹¹⁴ and that the windlass was only used in exceptional situations.

CHAPTER V

THE *NEWASH-MINK* INCIDENT AND BORDER RELATIONS

On 27 September 1815, the two sister schooners were once again in company with each other, lying at anchor off Fort Erie.¹¹⁵ *Newash* was loading stores for transport to Amherstburg, a British post on the eastern shore of the Detroit River (see fig. 1). Lieutenant George Surratt, commander of H.M. Schooner *Sauk*, was returning to his vessel, lying off Amherstburg. *Tecumseth* was bound for the naval establishment at Grand River. On 28 September the two schooners set sail up the lake.

Three days later, *Newash* was sailing amongst the islands at the western end of Lake Erie. Bushby observed a small schooner, sailing from the direction of the Detroit River. With Lieutenant Surratt eager for news of his schooner, Bushby attempted to hail the other vessel and inquire about the *Sauk*:

On my passage from Fort Erie to Amherstburg, on the first of October last, I met a Schooner on the N.W. Side of Middle Island at which I fired a musket, she hoisted American Colours, as she did not shorten sail nor attempt to pass within hail, I fired another, she then brought to and hoisted her boat out, I then tacked and hove to close to her and desired her to send her boat on board, and the Master came on board, after having inquired where she came from, where she was bound, and whether she had passed any Men of War at Amherstburg I told the Master he might proceed.¹¹⁶

The American schooner was named *Mink*, and was said to have been in the employ of the British Commissariat.¹¹⁷ The incident made a distinct impression on at least one passenger aboard *Mink* at the time. Shortly after the schooners' encounter, an editorial appeared in the *Niagara Journal*. The editorial was informed by the events witnessed by the passenger aboard *Mink*, although it contained a very different description of the incident than that recorded by Lieutenant Bushby.

British Outrage!

The American Schooner *Mink*, Captain Hammond, on her Passage from Detroit to Buffalo, when passing the British Armed Schooner *Nawash*, [sic] Lieut. Drury, [sic] on the 1st Instant, near Ballast Island, about two Miles [3.22 km] from Put-in Bay, was fired upon by the Schooner without being hailed, or receiving the least other previous intimation.

–The shot passed just over the Bowsprit of the *Mink*.– Captain Hammond immediately hoisted American Colors supposing that to be the object of the British.– Another shot was then fired from the Schooner, which passed through the foresail of the *Mink*, not four feet from where the Passengers were standing on the Deck.–

Captain Hammond then brought his Vessel to, although there was great danger in doing it, of falling on the Breakers.

–The British Commander ordered him to send his Boat on board the *Nawash* [sic]– the Boat was accordingly got out, and Captain Hammond went aboard.–

After making a number of trifling inquiries relative to the News at Detroit, and the Passengers he had aboard, the British Officer ordered him to return to his Vessel, without assigning any reason for his outrageous Conduct!¹¹⁸

The unnamed editorialist presumed that the *Mink* had been brought to so that Lieutenant Bushby could search for and potentially reclaim British deserters. Seen from that light, the *Newash-Mink* incident touched on the tender subject of British impressment of American citizens.

The matter of impressment had been one of the key aggravations that led the American government to declare war against the British in 1812. Americans perceived the issue as a threat to their national sovereignty, and the issue was particularly sensitive to the Americans. Thomas Jefferson, writing just as he received word of the peace, noted, “I am glad of it, although no provision being made against the impressment of our seamen, it is in fact but an armistice, to be terminated by the first act of impressment committed on an American citizen.”¹¹⁹ Some British officers, however, felt it was within their rights to reclaim deserters from their forces and in the Great Lakes region desertion was a problem among the British naval and military ranks.

With the refuge of the American border so close, desertion was an easy solution for disgruntled sailors, and additional temptations of absconding with money or equipment often enticed men to leave their posts. Lieutenant James Jackson, commanding H.M.

Schooner *Huron*, reported that three men deserted the vessel with one box containing 500 pounds (£) and upwards of another 100 pounds (£) as well as one of the ship's boats.¹²⁰ The next year a similar event occurred on the same vessel. In May 1816, Edmund Burton, Naval Storekeeper, received 2000 pounds (£) to cover expenses of the Lake Erie establishment. Burton joined the crew of the schooner *Huron*, where word soon spread of the small fortune on the ship. Three men stole the money and quickly deserted the schooner.¹²¹

The Case of Lieutenant Alexander Vidal

When they could be located, deserters might be pursued by crewmembers from their old ship, even into American lands. On one such occasion, Lieutenant Alexander Vidal was imprisoned in Michigan after pursuing a group of deserters from H.M. Schooner *Confiance*. The deserters had absconded with two of the schooner's boats and some clothes from the vessel's stores while she was near the head of the Saint Clair River, in September 1815.¹²² Lieutenant Vidal pursued the deserters on shore and found one of the men. The man claimed he had not meant to desert the schooner, and did not object when he was returned to her. Vidal also learned that the pilfered items were in a public house, and set out to find them. While on his way, Vidal was accosted by a Michigan militiaman and arrested. The lieutenant was charged with "forcibly seizing and transporting a person, name unknown,"¹²³ a charge amounting to impressment.

The sailor who had been returned to *Confiance* later denied that he had sought American protection, and stated that no force had been used to bring him back to the schooner, but this was little help to Lieutenant Vidal. After his trial was delayed on several occasions, Vidal was finally in court Detroit in mid-October.¹²⁴

The verdict was mixed:

[G]uilty of having riotously and routensly [sic] assembled an armed party to seek Deserters, with having searched the house of one of the Citizens, and with having disturbed the peace of the Inhabitants but acquitted...of taking the Man forcibly from the Land.¹²⁵

Though the impressment charges did not stand, Michigan Governor Lewis Cass made a strong statement on the issue. Because of American sentiment on the issue, government representatives from both sides were consulted on the case. E.W.C.R. Owen brought the matter to the attention of British secretary Anthony Baker,¹²⁶ and Cass sought advice from authorities as well. Vidal was imprisoned for over a month before being brought to trial. He was forced to pay an “enormous sum”¹²⁷ of money, including court and attorney fees, but eventually returned to his ship.

Lieutenant Vidal’s case is probably the most noteworthy concerning a particular individual, for the controversies that erupted between British and American neighbors usually concerned vessels. In fact, it was far more common that vessels would be

detained in an incident, rather than individuals who might have been involved. Two incidents, one on Lake Ontario and the other on Lake Champlain, reflect this tendency and suggest that tensions were high all along the border, not only on the western frontier.

Seizure of Julia

On Lake Ontario the British and American shipbuilding centers were in close proximity, both located at the eastern end of the Lake. In mid-October 1815, the schooner *Julia* was sent to the American shore to procure a load of hay that had been purchased for the dockyard cattle.¹²⁸ *Julia* was a merchant vessel, captained by John Robson, but was in the employment of the Royal Navy dockyard at Kingston. On 15 October 1815, a boat with eight men from the American post at Sackets Harbor intercepted the schooner. *Julia* was taken on orders from the Customs Collector, and detained for “Violating their Laws in not entering at the Custom House, and for taking away the produce of the country, without giving any account of it.”¹²⁹

The Americans struggled to get the schooner underway. Robson had tucked the schooner into a temporary anchorage, with a shoal nearby. The diligent captain was in a curious situation, and concerned for the safety of his vessel. “[F]earing loss through their Ignorance they might run her aground; [Robson] offered to take charge and get her underweigh [sic].”¹³⁰ *Julia* and her crew arrived safely in Sackets Harbor.

The Judge at Sackets Harbor, perhaps realizing the sensitive nature of the circumstances, determined to write to the American government regarding the schooner. In the

meantime, the schooner was detained and the crew returned to Kingston. Captain Robson was not eager to leave his vessel unattended, regardless of the circumstances. He remained onboard until ordered to leave on 28 October 1815.¹³¹

Customs House Boats on Lake Champlain

The British base on Lake Champlain was actually located ten miles (16.09 km) inside the Canadian border, on the Richelieu River at Isle Aux Noix. In the fall of 1815, a United States Customs House boat pursued a vessel into the river. When approached by Captain William Baumgardt, in charge of the naval establishment at Isle Aux Noix, the commander of the customs boat claimed the vessel was stolen, then claimed she had been smuggling. Baumgardt admonished the customs ship's captain, ordering that the ship return to her port. He detained the suspect vessel but not her crew, and wrote to authorities for instructions as to how to proceed.¹³²

Captain W.F.W. Owen, who succeeded his brother, E.W.C.R. Owen, as senior officer on the Lakes in late 1815, was infuriated by the incursion of the customs boat. He wrote to Sir Gordon Drummond, then Governor of Upper Canada, to inform him of the “unnecessarily aggravating and vexatious tenacity” of the American vessel.¹³³

The matter of British and American relations on the Great Lakes weighed heavily on the minds of both Owen brothers. In late 1815, E.W.C.R. Owen wrote of his concerns regarding “how much the authority of Government and Justice is weakened by its

distance from the seat of the Government, by the irregularity and difficulty of communication and the want of a Superintending power immediately at hand.”¹³⁴ He wanted to strengthen the British presence in Canada, and maintain a military superiority over the Americans:

To this we may impute in some degree the growth of American feeling and Connexion [sic] which will require a firm and steady hand to wean them from, and prove to them (as is the fact) that the Interest of that portion of the United States which borders on the Lakes is much more in our hands, than that of the British Colonists can be in theirs.¹³⁵

W.F.W. Owen was understandably concerned over the state of affairs between the two countries. He pointed out that “the recent occurrences [sic] on the more distant parts of the Frontier [have] so much the character of Enmity and so little of a Pacific disposition.”¹³⁶ The governments in London and Washington may have been ready for peace, but in the immediate aftermath of the War of 1812, the atmosphere of amity was not yet present on the Great Lakes frontier.

CHAPTER VI

WINTER ON LAKE ERIE

As the schooners were being built and outfitted at the Chippewa River, work was also underway at the new naval establishment. The creation of a naval depot on Lake Erie became necessary, as overland transportation to Lake Huron proved difficult and unpredictable.¹³⁷ In early April 1815, E.W.C.R. Owen recommended that an appropriate area for construction of a *Newash/Tecumseth*-type schooner be surveyed. John Harris and John Aldersly were sent to examine several areas along the length of Lake Erie, and returned a recommendation that the naval establishment be founded on the banks of the Grand River:

But the most eligible spot that I can find is on the West Bank of the River near the Mouth of the Grand [where the land] is sufficiently hard to lay ways for building upon and a sufficient depth of water to launch ships of considerable burden, capable of being well defended in times of War, when the banks being high on both sides of the River on the back of which there is almost impassable Swamps extending up a considerable distance.¹³⁸

The region also contained gypsum and pigment, and Captain Bouchier learned of “a considerable vein of lead [which] exists upon a creek which falls into the River.”¹³⁹

Overland transportation to the establishment at Grand River was far easier than the routes to Lake Huron, and could be aided by the construction of a canal to Burlington Bay, on the western shore of Lake Ontario.¹⁴⁰ Captain W.F.W. Owen, who had also surveyed the area, indicated that “The importance of Grand River as a Naval Station

must depend very much on its being adopted as a line of communication between the two lakes.”¹⁴¹

Captain W.F.W. Owen had some concerns over the physical situation at Grand River, however. The mouth of the river was obstructed by a sand bar, which restricted its depth. Aldersly described the mouth of the river, the bar, and how the depth was affected by the weather:¹⁴²

The mouth of the river is capable of being easily defended, but the bar at the mouth is so shallow as not to admit vessels of any burthen. The river preserves a uniform breadth to the mouth, which is narrow, only 132 yards [120.73 m]. I had an opportunity of seeing the effects of a gale of wind on the bar. The day before there was 9 feet [2.74 m], the day after only 6 [1.83 m]. The channel over the bar is very narrow. The river at this period is 4 feet [1.22 m] higher than it has ever been known. Inside of the mouth here is 30 feet [9.15 m] above this 24 feet [7.32 m] 3 miles [4.83 km] up.¹⁴³

W.F.W. Owen pointed out that “without measure the bar will only permit vessels which draw less than 6 feet [1.83 m].” He was of the opinion that “Turkey Point is the best place for a Naval Force – deep water, good Harbour, room for an arsenal.”

Nevertheless, Grand River was selected for its defensible land and adequate natural resources, and artificers and stores were sent to create a naval establishment at this locale. E.W.C.R. Owen wrote, “the first object at the place...will be erecting Barracks

and preparing Ground for the future construction or repair of Ships.”¹⁴⁴ Aldersly had noticed an abundance of several types of timber that could be used for ship construction:

Round and upon the banks of the Grand River there is Timber of every description in abundance applicable to the purposes of Ship Building particularly oak and Pine. The oak is of the best quality (what we term the Blue Swampoak)...Pine sufficient for masts of any size...There is also Beech, Ash, Hickory and Butternut.¹⁴⁵

The crews of *Tecumseth*, *Newash*, and *Huron*, which all wintered at Grand River, plundered the nearby forests of timber for firewood.¹⁴⁶ The crews augmented the regular establishment, which consisted of one quartermaster of shipwrights¹⁴⁷, six shipwrights, two sawyers, two smiths and a horse.¹⁴⁸ These men were directed to obey Captain Bouchier’s orders, but “not to be subjected to naval discipline.”¹⁴⁹ The lake establishment also included four schooners: *Newash*, *Tecumseth*, *Huron* and *Sauk*. The two larger schooners each had a crew of 30 men, and the smaller schooners carried 18 apiece.¹⁵⁰ Other clerks and artificers, including a sailmaker, a ropemaker and a gunner, brought the total number of men to 137.¹⁵¹

Getting the larger schooners into the Grand River was a challenge, and a good portion of the establishment was required to assist when they entered. Captain Bouchier was certain he could lighten the ships to get them over the bar, but the depth of water was continually variable. At one point in early fall 1815, E.W.C.R. Owen considered the

possibility of constructing a “mole”¹⁵² in Mohawk Bay (just off the entrance to Grand River) to lay the ships up for the winter.¹⁵³

No mole was constructed, though, and when the schooners arrived in mid-November 1815, they were downrigged and unloaded.¹⁵⁴ The unloading of each schooner was assisted by her own jolly boat, which was hoisted onboard for passages. In addition, the naval establishment’s ten small vessels (Table 1) were available to give assistance.

Table 1: Boats and Batteaux Belonging to Lake Erie Establishment, 31 December 1815¹⁵⁵

Vessel	Length	Beam	Oars	How Rowed
Black Gig	25 feet (7.62 m)	4 feet 4 inches (1.32 m)	5	Single-banked
Green Gig	22 feet (7.62 m)	5 feet 0 inches (1.52 m)	5	Single-banked
Yellow Gig	25 feet (7.62 m)	5 feet 5 inches (1.65 m)	6	Single-banked
White Cutter	25 feet (7.62 m)	7 feet 1 inch (2.16 m)	10	Double-banked
Black Cutter	25 feet (7.62 m)	6 feet 8 inches (2.03 m)	10	Double-banked
Jolly Boat	16 feet (4.88 m)	6 feet 0 inches (1.83 m)	8	Double-banked
Jolly Boat	16 feet (4.88 m)	6 feet 0 inches (1.83 m)	8	Double-banked
Jolly Boat	15 feet (4.57 m)	5 feet 10 inches (1.78 m)	4	Single-banked
Batteaux	36 feet (10.98 m)	7 feet 8 inches (2.34 m)	10	Double-banked
Batteaux	35 feet (10.67 m)	7 feet 0 inches (2.13 m)	10	Double-banked

*All clinker-built, all steered by rudder except batteaux, which were steered by oar.

The plan to carry the larger schooners over the bar involved deploying an anchor some distance ahead and hauling the vessels, by hand, to the anchors. Second Master Childs logged the heaving on 12 November 1815: “[G]ot Purchase on the Cable and heaved without Difficulty.”¹⁵⁶ The next morning, the crew was still at work: “[G]ot all the

Marines onboard got a purchase on the Cables all hands heaving...at 2 [pm] hove her off the Bar and Anchored in the Grand River. [F]ound lying here the *Newash*.¹⁵⁷ H.M. Schooner *Huron* joined the small fleet in the river on 18 November 1815,¹⁵⁸ though she ventured once more into the lake and anchored again in the Grand River on 21 December.¹⁵⁹

The schooners lined up on the east bank of the river. The situation of the establishment had been named Lynnowen,¹⁶⁰ perhaps to distinguish it from the rest of the Grand River. To secure the vessels, they were moored with hawsers led onshore to trees.¹⁶¹ Working parties from each schooner were sent onshore to assist in gathering firewood and provisions for the coming winter, as well as to make preparations for the considerable work which was to take place at Grand River.

E.W.C.R. Owen had directed that *Newash* and *Tecumseth* both undergo rigging changes. He had seen the vessels in person both under construction and later the same month, after *Tecumseth* had been remasted.¹⁶² Perhaps his recommendations that the rigs be altered were based on observations made at those times.

Re-Rigging the Ships

It seems evident from Captain Bouchier's comments and Second Master Childs' description that *Tecumseth*'s dismasting in September 1815 was an unfortunate result of high seas and a loose rig. E.W.C.R. Owen, however, may have suspected a flaw in the

sail plan of the schooners. In his instructions for the establishment on Lake Erie, dated 12 October 1815, E.W.C.R. Owen ordered that both schooners' rigs were to be altered during the winter of 1815 – 1816.

Newash was to be rigged as a brigantine, with a slightly different sail plan. The mainmast remained somewhat similar, but the yards that had supported the square sails were removed. The mainsail was the same, but above it a gaff topsail, a fore-and-aft sail, was hoisted. The new foremast assembly consisted of a fore lower mast, fore topmast, and fore topgallantmast;¹⁶³ each carried a square sail. Between the masts, a fore-and-aft main topmast staysail was rigged on the main topmast stay. There were two headsails, called the fore topmast staysail and the jib, and the headrig was supported by the addition of a sprityard. The sprityard hung horizontally, just below the bowsprit. In addition to her regular sail plan, *Newash* could also carry a topmast studdingsail, which was set outboard of the fore topsail, usually on the weather side. To accommodate this new rig, the foremast was moved aft, and a new mast step was constructed. John Jewell, quartermaster of shipwrights, recorded “cutting new mast hole” and “shifting three streaks [strakes] of deck in wake of mast hole” in late December.¹⁶⁴ A blacksmith was employed “making bolts for bolting steps of fore mast and tressle [sic] trees.”¹⁶⁵

Tecumseth's rig was also altered that winter. Like *Newash*, she was fitted with a gaff topsail on the mainmast, and a main topmast staysail between the main and fore masts.¹⁶⁶ E.W.C.R. Owen also noted, “To enable the *Tecumseth* to set her fore topsail

lower on the mast by settling the fore yard in bad weather till the topsail yard is close upon the cap, her schooner foresail is to be fitted with a trysail mast.”¹⁶⁷ The trysail mast was a smaller-diameter mast, stepped on deck immediately abaft the fore lower mast. The foresail gaff was attached to the trysail mast, while the foreyard, which stretched the foot of the fore topsail and the head of the square foresail, was attached to the fore lower mast. This allowed the gaff and yard to be raised and lowered independently of each other. The two new rigs would remain unchanged until the end of the vessels’ sailing careers.

Life at Grand River

The shipwrights at Grand River did most of the work to alter the ships’ rigs. That left the crews to other tasks around the establishment. After the barracks, a blacksmith’s shop was constructed.¹⁶⁸ A working party cut a road from the establishment to Sugar Loaf, about ten miles (16.09 km) west of Point Abino. On 18 January 1816 the guns were thoroughly cleaned and a 21-gun salute was fired in honor of His Majesty’s birthday.¹⁶⁹ When a sailmaker onboard *Tecumseth* added several reef bands to her sails, the crew made points for the new reefs and also mended the signaling flags.¹⁷⁰ The spars were painted or blacked and the rigging was repaired.¹⁷¹

The schooners were intermittently frozen in the icy river, with snow and rain falling throughout the winter. Finally, in late March, the ice began to break up around the hulls. After soundings were taken of the bar at the river’s mouth,¹⁷² the vessels began setting

up their rigging and bending sails. It would be difficult to transport the large spars of the rig out to the vessels at anchor, so the rigs were left in place when the ships attempted to cross the bar. This also allowed the ships to use their sails if necessary. Provisions and stores were landed onshore by the establishment's boats to lighten the hulls.

Crossing the Bar

Being the shallowest of the three ships at Grand River, H.M. Schooner *Huron* was the first to attempt to cross over the bar, on 18 April 1815.¹⁷³ A boat's crew from *Tecumseth* was sent to assist in towing her when she struck, to no avail. Eventually, *Huron* returned to the river, unable to cross. *Tecumseth* sent a boat to sound the bar on several occasions, and a 5- to 5.50-foot (1.52 to 1.68 m) deep channel was found and marked with buoys. The lightened hull of *Tecumseth* still drew 7 feet 2 inches (2.18 m) aft and 5 feet (1.52 m) forward. To help raise the schooner higher, casks or puncheons were lashed under the hull.¹⁷⁴

Early on the morning of 22 April 1816 *Tecumseth* set out, but at 7:45 a.m. struck the bottom in 6 feet 6 inches (1.98 m) of water. To kedge her off, two anchors were led ahead of the schooner and for extra purchase in hauling on the cables, a "Luff upon Luff" purchase was rove. A single luff tackle (fig. 11) provided three times more hauling power than no tackle at all, and two single luffs together yielded nine times that

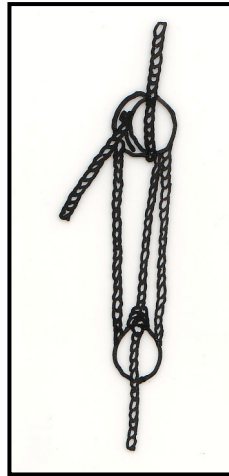

Figure 11: Single luff tackle.

applied. If double luff tackles (fig. 12) were used, the factor would have been twenty-five. Childs observed the vessel “Grinding much;”¹⁷⁵ with the hull hard aground and grating across the bar, the crew “Launched the Main Boom and other Spars overboard.”¹⁷⁶

The next morning the operation began anew:

At Daylight a Breeze from the Northward set the [fore] Top Sail Top gallant sail and Square Sail all hands heaving at Windlass sent powder on shore Galleys and everything to lighten layed [sic] the...Anchor Out [a]head Sallied the people from side to side to Clear her Bed Cables Coming in much chafed water Shorting to five feet four inches [1.63 m] all three Anchors coming home stoppered the Cables and handed sails.¹⁷⁷

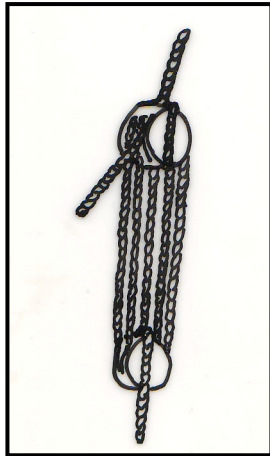

Figure 12: Double luff tackle.

The crew was directed to run across the deck of the ship, rocking it from side to side. This, it was hoped, would clear the keel from the sandy bottom. With men heaving at the windlass, the hull continued to scrape across the bar. The fiber rope attached to the anchor rubbed against the hawsehole, where it came into the hull, causing the fibers to chafe and break. With a northerly breeze, the square sails should have driven the ship southward, but as Aldersly had noticed the previous summer, certain winds blew the water out of the river, causing the depth to decrease over the bar. The crew watched the depth drop more than a foot while their vessel sat stationary. With the vessel so stubbornly stuck, the anchors had no effect and were dragged over the bottom by men hauling on the cables.

The next day brought no change in the depth, but *Huron* was able to cross the bar and get ahead of *Tecumseth* and a cable was run between the schooners. All excess weight, including the crew's hammocks, was sent onshore to lighten the ship. Sundown brought

no change in *Tecumseth*'s position, and the hammocks were brought back onboard so the crew could sleep.¹⁷⁸

At daylight on 25 April 1816, the crew was roused and their hammocks again sent onshore. Later that morning, a breeze filled in from the south and the depth of water began to increase. Crews from the other ships were brought onboard to haul at the cables. The efforts of the crews finally paid off on 27 April 1816, six days after the operation had begun. The depth over the bar had been just over 5 feet (1.52 m), but rose slowly to "6 and 7 feet [1.83 m and 2.13 m]"¹⁷⁹ and the schooner cleared. In spite of all the efforts to lighten the hull, Childs recorded a draft of 7 feet 7 inches (2.31 m) aft just after *Tecumseth* crossed the bar.¹⁸⁰ In celebration and acknowledgment of their efforts, the crew "spliced the Main Brace [were given an extra ration of rum]"¹⁸¹ and went to Dinner,"¹⁸² and then set about clearing the decks and preparing to assist *Newash* over the bar.

Onboard *Newash*, the shot and powder were sent onshore, as well as the coppers (used in the galley for cooking), and fore yard. Casks were bowsed under the hull to raise it.¹⁸³ With southwesterly breezes on 29 April 1816, *Newash* hauled off from her anchorage and stood into the river. She quickly ran aground and sent anchors out to kedge the vessel off.¹⁸⁴ After the amount of time *Tecumseth* had spent on the bar, a new tactic was attempted with *Newash*. The heaving was done from the decks of *Huron* and *Tecumseth*, which were already over the bar. Men from *Newash* and the naval

establishment were sent to the other schooners, to keep *Newash*'s hull as light as possible. The empty hull was towed over the bar by the two schooners in the lake.¹⁸⁵ Falling water levels plagued *Newash* as well, and when she finally scraped over the last of the bar on 1 May, her rudder was unshipped.¹⁸⁶ The rudder was re-hung, the rigging rove, and both ships were ready to sail the lake again in early May.

The whole squadron loaded provisions at Fort Erie and transported them to Nottawasaga and Drummond Island, on Lake Huron, where British troops had constructed a depot after leaving their former base at Fort Michilimackinac.¹⁸⁷ Perhaps because of the difficulties and amount of time it took *Tecumseth* and *Newash* to cross the Grand River bar,¹⁸⁸ the two vessels were officially transferred to the Lake Huron fleet in 1816, though they continued operating on both lakes. The depots on Lake Huron – Nottawasaga, Drummond Island and Penetanguishene – each provided a potentially better situation for larger vessels. In spite of these better situations, both schooners spent the winter of 1816 – 1817 at Mohawk Bay, just off the mouth of the Grand River.

Later Seasons for the Vessels

Tecumseth and *Newash* continued to sail the waters of Lakes Erie and Huron, usually in company with each other. Occasionally, the close proximity of the two ships caused problems such as two episodes in late 1816 when the ships ran into each other. On 17 November *Newash* fell onboard *Tecumseth* and carried away the brigantine's boat davit.¹⁸⁹ Less than a month later, on 13 December, *Newash* again fell onboard

Tecumseth and carried away her spritsail yard.¹⁹⁰ That year, both vessels wintered in deeper water at Mohawk Bay. The crews kept busy by cutting firewood in nearby forests, and working on their vessels, and the guns were exercised regularly,¹⁹¹ certainly a notable event as the noise must have echoed across the icy water.

On 20 April 1817, *Newash* hoisted the “blue peter,” a signal flag used by an outward-bound vessel, at the start of what would prove to be her last sailing season. Lieutenant Henry Kent was in command of *Newash*, having been transferred the previous fall when *Tecumseth* was registered as a Sloop of War and *Newash* as a Schooner.¹⁹² Lieutenant Thomas Bushby, formerly commanding *Newash*, was transferred to the schooner *Sauk*¹⁹³ and Lieutenant Abraham Whitehead came aboard *Tecumseth* from *Sauk*.¹⁹⁴

CHAPTER VII
CAPTAIN WILLIAM BOURCHIER AND THE DISARMAMENT OF THE
GREAT LAKES

The British officers who commanded squadrons on the lakes of Canada, and some of the men who worked under them, were used to warfare. These men had come of age steeped in the Napoleonic wars in Europe, and were offered their own commands during the War of 1812. Part of the reason for some of their potentially volatile acts on the frontier may be that they simply did not know how to be officers at peace. W.F.W. Owen described the task of transporting stores as “a Service so essentially different from our usual employment.”¹⁹⁵

Additionally, the Great Lakes put these officers into a very unique position. The Treaty of Ghent secured the rights of both nations to navigate the waters of the lakes freely. While meant as a gesture of reconciliation, this article essentially encouraged smuggling and asked that whatever authoritarian vessels might observe it to turn a blind eye. On Lake Erie, Captain Bouchier encountered this situation directly.

Bouchier was a zealous officer who was wary of his assigned post. Lake Erie, like other frontier posts, was painfully distant from Kingston and familiar British influences. While at Grand River, Bouchier felt exposed not to Americans but to natives and Canadian settlers in the region. After the first winter at the establishment, Bouchier wrote, “If a permanent Establishment is to be formed on the Grand River, I should hope

the Government would hold possession of all the Land for Four Miles (6.44 km) up the River.” He pointed out that “the Timber on the Land would be of use to the Government and a Mill seat might be found.” It seems that Bouchier did not trust anyone outside of the Royal Navy. “[T]he less communication with our present neighbours [sic] the better. Settlers such as we have can be of no use to any Establishment, the Grand River having been a Rendezvous for Vagabonds.”¹⁹⁶ During the winter at Grand River, Bouchier acted as magistrate both for the men at the naval establishment and settlers on nearby lands. He felt the duty within his realm, the establishment being so far removed from any other seat of authority.¹⁹⁷

In much the same vein, Bouchier felt obliged to take on the task of enforcing revenue laws on Lake Erie. At both ends of the lake, American territory was in extremely close proximity, and the unguarded expanses of Lake Erie allowed plentiful opportunities for illegal trade and smuggling. Bouchier was certainly aware of the lake’s legacy and popular sentiments on the late war. Bouchier wrote of his assignment, “I am well aware we are placed on Lake Erie, on a very ticklish footing.”¹⁹⁸

Finding the four vessels – *Huron*, *Newash*, *Sauk* and *Tecumseth* – under his command the only royal authority on Lake Erie, Bouchier determined to use them to support the government of Upper Canada. Bouchier instructed the lieutenants commanding the vessels to keep a close watch on suspected smugglers. W.F.W. Owen seemed to support

Bourchier's determination, and wrote to Lieutenant Governor Francis Gore in the spring of 1816 for verification:

[Captain Bourchier] has directed His Majesty's Naval Officers to aid and support the Government of this Province in the execution of the Revenue laws, it being notorious that smuggling is carried on to very great extent on the whole of our Coast – far as the Thames [River], to the very great detriment of the Country... The prevention of smuggling would be a direct object of pursuit to engage the attention of the Naval Service on the Lakes and would operate more than any other regulation to bring it to perfection, by insuring to its Officers the best local knowledge and most fitting experience I would ask for you to allow Officers, Boats and Crew to carry out these duties... and also that we be furnished with... the revenue laws and Coast regulations.¹⁹⁹

W.F.W. Owen acknowledged that he was “not aware how far the Laws of Great Britain apply in such a case to this Province,”²⁰⁰ but was surprised by the response he received from Gore. Gore felt that the current civil authority was sufficient for the enforcement of its own laws, and refused to grant such authority to the Royal Navy. Darcy Boulton, Attorney General, elaborated:

The British Statutes are confined to the Sea... but in this part of the Globe, I am of the opinion that the Navy can have no Authority in times of Peace, unless Authorized by an Act of Parliament... Vessels of the United States... may pass unmolested, unless directed by the [Customs] Collector.²⁰¹

Lake Erie is connected to Lake Huron by two rivers, the Detroit and Saint Clair, and a small lake, Lake Saint Clair. Ownership of several islands in the two rivers was still disputed after the end of the war. Among these was Bois Blanc Island, near the British depots at Amherstburg and Fort Malden. A small channel separated Bois Blanc Island from the mainland of Canada. Though it was not official, the British viewed the island as their territory. Another channel on the western side of Bois Blanc Island also offered adequate passage.²⁰² Bouchier felt that if the mainland and offshore island were British, then the channel between them was under royal jurisdiction. Bouchier may not have received W.F.W. Owen's communication on the role of the Royal Navy when he issued a verbal order on 31 May 1816 to board and search all vessels transiting the channel off Amherstburg. Bouchier delicately clarified his position in a written order issued nearly two months later:

Herewith you will receive a chart of the river Detroit which has not been finished. You will ascertain the soundings between the Island of Bois Blanc and the U.S. Should there be eleven feet [3.35 m] water you will board all vessels passing through the Port of Amherstburg.²⁰³

Both Lieutenants Kent and Bushby began bringing to vessels for boarding and searching, which quickly aroused American interest and anger. The activities and whereabouts of some American vessels, such as the schooner *Ghent*, were recorded in logbooks and transmitted between vessels. *Ghent* was suspected of housing British deserters, and had

been boarded off Buffalo, New York.²⁰⁴ When she was spotted again in Lake Erie, Second Master Childs noted her actions, even recording the time she tacked.²⁰⁵

Another boarding incident involved the American brig *Union*. While transiting the Detroit River, the *Union* sailed into the passage east of Bois Blanc Island. H.M. Schooner *Tecumseth* brought the brig to, boarded and searched her. Though the incident did not appear to disturb the master of the *Union*, an irate passenger brought the matter to the attention of Lewis Cass, Governor of Michigan. The passenger's story claimed that the British naval officer was "supported by the Officer at [Fort] Malden, who drew out some pieces of cannon, and placed them in a situation to bear upon the American Vessel."²⁰⁶ Major Berwick, commanding officer at Fort Malden, formally denied the accusation. Lieutenant Kent did not feel that any indignity had been offered *Union's* officers, as "they have always been treated as the subjects of a Nation at Amity with His Majesty."²⁰⁷

Apparently, the Americans did not consider the channels to the east and west of Bois Blanc Island as British waterways, and saw no reason to avoid either one. Governor Cass viewed the eastern channel as "the usual Channel"²⁰⁸ of communication between Lakes Erie [and] Huron."²⁰⁹ Cass believed the situation warranted the federal government's attention:

In an aggression like this the Government of the United States can alone determine what course the honour [and] interest of the Nation require should be taken.

But until their decision shall be made upon the subject, it becomes my duty to remonstrate against a practice for which the Laws of Nations afford no pretence, which is inconsistent with the relations existing between our respective Governments, [and] the continuance of which must be attended with serious [and] important consequences.²¹⁰

The boarding of the *Union* and the other actions on Lake Erie were brought to the attention of British Minister Plenipotentiary Charles Bagot, in Washington D.C. Bagot was already involved in negotiations over the finer post-war details, such as the number and size of the naval force on the Great Lakes. At the same time, Captain William Baumgardt, who had succeeded Captain W.F.W. Owen as senior officer on the lakes of Canada in, heard of the orders issued by Captain Bouchier.

Baumgardt felt that Bouchier had overstepped the bounds of his authority, and was concerned about the effect that Bouchier's actions would have on Anglo-American relations. "It is to be regretted that you should ever decree it necessary without reference to your commanding officer to adopt such measures as may in their operation, compromise the good understanding of the two Nations."²¹¹

The Rush-Bagot Agreement

Negotiations had been underway since the signing of the Treaty of Ghent to ensure long-term stability in the affairs between the naval powers. Charles Bagot communicated regularly with Secretary of State James Monroe throughout much of 1815 and 1816. Monroe and the rest of the American government felt that naval power should be severely limited on the Great Lakes, as “[maintaining] on the Lakes a large Naval Force, it would expose both [nations] to considerable and useless expence [sic] while it would multiply the risks of collision between them.”²¹²

Along those lines, John Quincy Adams, one of the American negotiators at Ghent, had proposed a drastic reduction of force on both sides. Adams’ proposal called for “one vessel on each of the lakes [less than or equal to] 100 tons burthen with one 18-pdr gun, [and] none on Lake Champlain.”²¹³ Though this proposal was made shortly after the peace, British authorities avoided consenting to any agreement for several months. The British, particularly Captain W.F.W. Owen, felt that conceding to the United States’ request to limit both countries to the same number and size of vessel would place the British at a disadvantage in North America and leave Canada particularly vulnerable to American encroachment:

[To] reduce our armed forces to a level with what they may without endangering their safety reduce theirs to, would be to reduce ourselves as much below their actual force as their Physical strength and attainable resources exceed ours.²¹⁴

American invasions of Canada during the War of 1812 left the British wary of reducing their naval force in areas where Canada was weak. W.F.W. Owen wrote of his fears regarding the potential result of such a scenario. Without a navy, he felt, it would cost exorbitant rates to transport men and stores. This would force the British to employ Americans, rather than their own subjects:

[W]hich would not only operate to cramp the industry [and] exertions of this infant colony, but would foster [and] nourish a race of people, who in our own employment, would acquire the most accurate knowledge to be applied against us in the event of a future war; whilst on the other hand we should be left in emergency to be defended by the resources [and] Men of the mother country at a hundred fold rate of expense as was the case during the late War.²¹⁵

Instead of a reduction of naval force that would place each country on par with the other, the British government proposed a gentlemen's agreement. Optimistically trusting the new spirit of amity between the two countries, Britain suggested that each nation reduce its naval force to the minimum required to perform the requisite duties. This would allow both nations "to act in a spirit of mutual confidence without shackling either by any precise stipulations."²¹⁶

The American position that without drastically reducing and limiting the number of naval ships on the lakes there would be more opportunity for conflicts between the two nations was ultimately the view that prevailed. American negotiators used the actions of

Captain Bouchier on Lake Erie as an example of aggressive use of warships, and the British had little to answer this charge. Even his fellow British officers had judged Bouchier's actions overly zealous and unnecessary. In spite of W.F.W. Owen's approval of some of Bouchier's policies and the fact that enforcement of revenue laws was eventually granted to the naval force, the manner in which Captain Bouchier had pursued his course left the British no point from which to argue. One zealous officer could shatter the brittle façade of peace with the right opportunity.

On 2 August 1816, James Monroe had proposed a new arrangement of reduced naval force. Each nation could retain one vessel on Lake Ontario of no more than 100 tons burthen, with one 18-pdr gun; two like vessels with like armament on the upper lakes; and one like vessel with like armament on Lake Champlain, but no more. Monroe's proposal further stated that:

[A]ll other armed vessels on those Lakes shall be forthwith dismantled, and likewise that neither shall build or arm any other Vessel on the shores of those Lakes...That the Naval Force thus retained by each party on the Lakes, shall be restricted in its duty to the protection of its Revenue laws, the transportation of troops and goods, and to such other services as will in no respect interfere with the armed vessel of the other parts.²¹⁷

Charles Bagot took this proposal to his superiors in London for their assessment, but a reply was not quickly formulated. In early 1817, Richard Rush was placed in charge of

the State Department in Washington, and entered into the negotiations. Finally, on 28 April 1817, Bagot received word that His Royal Highness was “willing to accede to the proposition made to [Mr. Bagot] by the Secretary of the Department of State in his note of the 2d of August last.”²¹⁸ Since Rush was signatory to the agreement, he shares eponymous credit for the Rush-Bagot Agreement, signed on 28 and 29 April 1816 in Washington, D.C.²¹⁹

CHAPTER VIII

DECAY AT PENETANGUISENE

The Rush-Bagot Agreement disarmed the Great Lakes and rendered *Newash* and *Tecumseth* obsolete. Even without their 24-pounder guns, the hulls were larger than 100 tons. Each vessel was to be laid up, stripped of guns and most other equipment, and left at anchor. Penetanguishene Bay, on Lake Huron, was chosen as the retirement home for the two hulls, and they arrived there on 18 June 1817.²²⁰ *Tecumseth* kedged to an anchorage near Dobson's (Magazine) Island²²¹ and *Newash* came alongside her sister and anchored "in 2 ½ fathoms [15 feet or 4.57 m] water soft bottom."²²²

After the sails were loosed one last time to dry,²²³ they were unbent from the yards, booms, gaffs and stays. Each of the masts was brought down and the smaller spars were laid on the decks. The rigging was unrove and stored, and the guns and carriages were placed in the holds.²²⁴ The ships were moored with iron cables,²²⁵ and the pennants were hauled down at sunset on 30 June 1817²²⁶ (fig. 13).

Many of the crew were dismissed from the vessels now in ordinary. Those who had earned them were given plots of no more than 100 acres in Canada. Even without land, some sailors chose to remain in Canada. Others were sent back to England on transports leaving from Quebec.

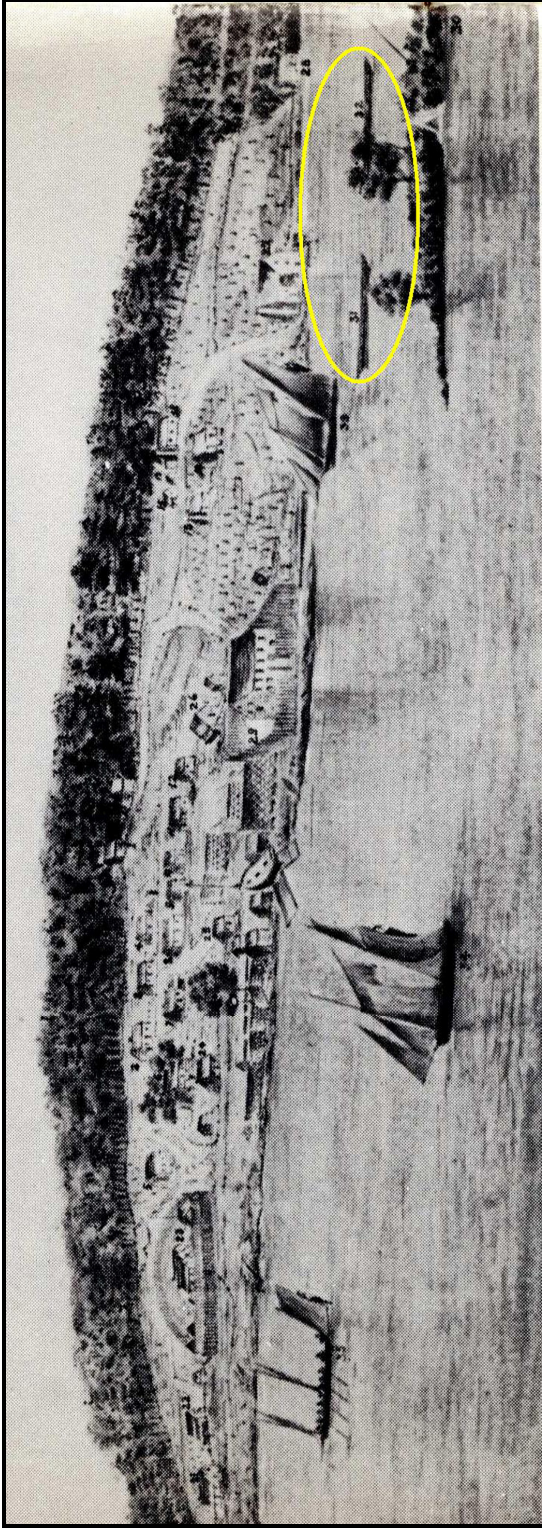

Figure 13: Penetanguishene Harbor with *Tecumseth* and *Newwash*, “31” and “32,” in ordinary. (Detail after H.F. Pullen, *March of the Seamen*, 18.)

Lieutenants Bushby and Kent both stayed at Penetanguishene after the vessels were laid up. Kent was appointed Superintendent of the naval yard at Penetanguishene, and set about constructing barracks and other buildings. Under Kent's direction, which lasted two years, the establishment would eventually include 18 buildings, saw pits, a steam kiln, a blacksmith's shop and two wharves.²²⁷ In spite of the new construction, the base began to fall into disrepair. The harsh Canadian climate contributed to the deterioration of the buildings.

Newash and *Tecumseth*, sitting in the harbor, also began to show signs of age in the years after the disarmament of the Great Lakes. In 1819 Commodore Robert Barrie, senior officer on the lakes, visited Penetanguishene and recorded the appearance of the naval depot:

This is one of our Naval Establishments. It is in a sad state. We have here two lieutenants, half a dozen seamen and as many shipwrights to look after two rotten schooners and some boats. The expense of conveying salt provisions and stores to this little out of the way place is nearly equal to a small dockyard.²²⁸

Barrie was made Commissioner of the Kingston dockyard in 1819, and was concerned with activities of the Americans. American expansion led to the improvement of transportation methods, including canals and railways. Barrie saw this type of construction as potentially threatening, as it increased American mobility. Improved mobility could prove dangerous to the British in times of future war. Though the British

planned similar construction in Canada, they had yet to keep pace with the Americans.

Barrie wrote on the contrast in construction on either side of the border in 1819:

[T]hough I do not believe they contemplate an early rupture with us, they are preparing for it – we too have Plans of Forts, Canals, and Roads drawn out on our maps, but not a spade is employed on the Canals so long talked of – and little done either to the Forts or Roads – in fact we seem to be laying on our Oars.”²²⁹

For a brief period from 1819 to 1822, the Royal Navy seemed once again interested in maintaining a war-ready fleet. In 1819 the two hulls sitting in Penetanguishene harbor were surveyed, and the expense of repairing them calculated. A vessel was needed to transport troops from Penetanguishene to Drummond Island. *Newash* and *Tecumseth* both bore the effects of dry rot in many of their timbers, including key structural members.²³⁰ The mast steps, deck beams, keelson, wales, bottom planking and parts of the frames were rotten.²³¹ *Tecumseth* underwent repairs and was outfitted to sail once more, albeit only briefly. *Newash* was to be repaired as well, after work was completed on *Tecumseth*,²³² but it is unlikely that this work transpired.

The costs and time involved in maintaining and repairing the aging vessels were too much for the small establishment. In 1821, *Newash* was used as the site of a reception for Lieutenant Governor Gore,²³³ but this was likely her last official duty. The following year, the Admiralty once again ordered that the lake establishments be reduced and

officers returned from foreign posts, which Canada was considered.²³⁴ Lieutenant Henry Kent returned to England in 1822, ten years after he had left in H.M.S. *Fantome*.²³⁵

By the mid-1820s, *Newash* and *Tecumseth* were rotten and sinking. Green, unseasoned wood had been used in their construction, allowing Robert Moore and his shipwrights to quickly deliver seaworthy vessels, but this sort of timber also shortened the life spans of the ships. The same fate befell the other ships that had been built at the end of the war. A survey conducted in 1827 noted that both vessels at Penetanguishene were “completely rotten...sunk,” and that *Newash* was “on the beach.”²³⁶

In 1831, the two hulls were among a list of naval stores to be auctioned off at Hollands Landing and Penetanguishene. Also listed were the smaller vessels *Bee*, *Mosquitoe* and *Wasp* as well as several of the establishment’s boats and batteaux.²³⁷ The auctions were held in March 1832, but neither *Newash* nor *Tecumseth* found a buyer, and instead remained at their watery berths. *Confiance* and *Surprize* had also sunk in the harbor by this time.

As the second quarter of the 19th century wore on, the British began to give up their strongholds in Canada and reduced their armed forces across the country. Like the establishment at Penetanguishene, the other depots on Lakes Erie and Huron became unnecessary, and fell into disrepair as well. A flood in 1827 washed away the wharf and

four buildings at Grand River, effectively destroying the depot.²³⁸ After the sale of stores and ships, the establishment at Penetanguishene was formally closed in 1834.²³⁹

Kingston remained a naval dockyard and depot in the post-war years, though its role diminished until the establishment closed in 1834.²⁴⁰ Barrie was Commissioner of the dockyard for the last 15 years of its existence, and kept many of the buildings in good repair. Today, Kingston is home to the Royal Military College of Canada, on the ground of the former Royal Navy establishments, and the city is considered the birthplace of the Canadian Navy.

The Rush-Bagot Agreement has been altered somewhat since its original conception. Both the United States and Canada use sites on the lakes, like the Royal Military College of Canada, as training centers for naval personnel. Coast Guard stations have also been set up on both sides of the border, but serve as bases for security and law enforcement, rather than military posts. Until 2001, the majority of Coast Guard vessels were unarmed, in compliance with the treaty. After September 2001, the United States Coast Guard sought to equip several vessels on the lakes with large caliber weapons, as a measure of national security. Since this was for policing and peacekeeping purposes, Canada conceded to the armament in 2003.²⁴¹ There are no standing navies on the Great Lakes.

CHAPTER IX

ARCHAEOLOGICAL AND HISTORICAL RESEARCH

The sunken relics of the War of 1812 were not lost to local memory; fascination with the War of 1812 preserved oral histories of the conflict into the 20th century. Anniversaries of particular battles and a rebirth of interest in the 1920s and 1930s led to the relocation and recovery of some vessels.²⁴² In 1927, the wreck of H.M. Schooner *Nancy* was recovered and put on display in Wasaga Beach, Ontario. Four vessels were rumored to be located in Penetanguishene harbor; locals claimed that the hulls of *Confiance* and *Surprize* were sunk at the west side of the harbor while another two wrecks, thought to be *Newash* and *Tecumseth*, could be found near Magazine Island.

In 1933 the town of Penetanguishene sponsored a recovery in which salvers “floated the wreck which we had seen in Colborne Basin [part of Penetanguishene harbor] across the harbor to the town dock and placed its picked bones in the town park.”²⁴³ Local historians suspected that the wreck was the American-built schooner *Scorpion*, a participant in the Battle of Lake Erie that was captured by the British in 1814 and renamed *Confiance*. The wooden remains attracted visitors and vandals alike, and over time, the hull was pillaged: “much of it...disappeared, being transformed into chairs, desks, gavels, walking canes, candlesticks, picture frames and other ‘souvenirs of the *Scorpion*’.”²⁴⁴ In fact, the wreck pillaged by souvenir hunters was too small to be *Scorpion*. Historian C.H.J. Snider later identified it as *Scorpion*’s smaller counterpart,

the American-built *Tigress*,²⁴⁵ also captured by the British in 1814 and re-named *Surprize*.

The 1953 Salvage of Tecumseth

The allure of the War of 1812 continued in the decades following the recoveries of *Nancy* and *Tigress*. In 1953, Professor Wilfrid W. Jury and students from the University of Western Ontario began an archaeological project on the grounds of the former naval establishment at Penetanguishene. Their survey was a success, mapping 30 buildings and entertaining 17000 tourists.²⁴⁶

Jury and his students included the vessels from Penetanguishene harbor in their plans as well. The scant remains of *Surprize*, *ex-Tigress*, were hauled onto the grounds of the old establishment. That spring, it was announced that the hull of *Scorpion* would be recovered, and Jury made preparations for a salvage attempt. He secured the services of a dredge and crew for one day in late August, and the town prepared for the re-emergence of the old schooner. An obvious hindrance to the efforts appeared almost immediately: no one had told Jury exactly where the wreck was located. Many of the individuals who had been involved in the recovery of *Tigress* twenty years earlier had passed away since those efforts. Nevertheless, Jury proceeded, determined to raise one of the two wrecks near Magazine Island. At 7:30 a.m. on 29 August 1953, the last day the dredge was available, “Operation *Scorpion*”²⁴⁷ began:

Surrounded by an armada of small craft armed with cameras, flashlights, microphones and equipment for speech-making and broadcasting, the dredge plunged its steel-toothed clamshell bucket into a buoyed area a hundred yards [91.46 m] from the bank, where the water was 15 feet [4.57 m] deep. A pause while the steel teeth crunched like fangs on a bone, and up rose the bucket, spewing jets of water, with a tapered black timber in its jaws. Motor horns among the growing gallery of automobiles and spectators lining the foreshore ‘sounded a peal of warlike glee’ as the derrick arm swung and the opening bucket dropped the timber on the dredge’s deck. Next was brought up a shorter mass of blackened oak, with a stout chain attached. This the ‘experts,’ pale augurs muttering low, pronounced a shank-painter, and none gainsaid their word – not even when murmuring, ‘*Newash* or *Tecumseth*,’ they diagnosed the next lot of oak and ironwork as the port forechains, waterways and channel. The pile of dripping wood and rusted iron grew on the dredge deck until both bows of the wreck had been demolished piecemeal, and the water was opaque with disturbed silt. Still the ship had not been budged.²⁴⁸

Jury and his crew worked late into the evening, until the remains were wrenched from their grave and hauled onshore (fig. 14). Several timbers had been dislodged from their original places on the hull. Twelve round shot were found, cleaned, and emblazoned with the name “*Scorpion*.”²⁴⁹ The wreck was examined by a number of experts²⁵⁰ who all reached the same conclusion. The wreck was certainly not *Scorpion*; it was too large.

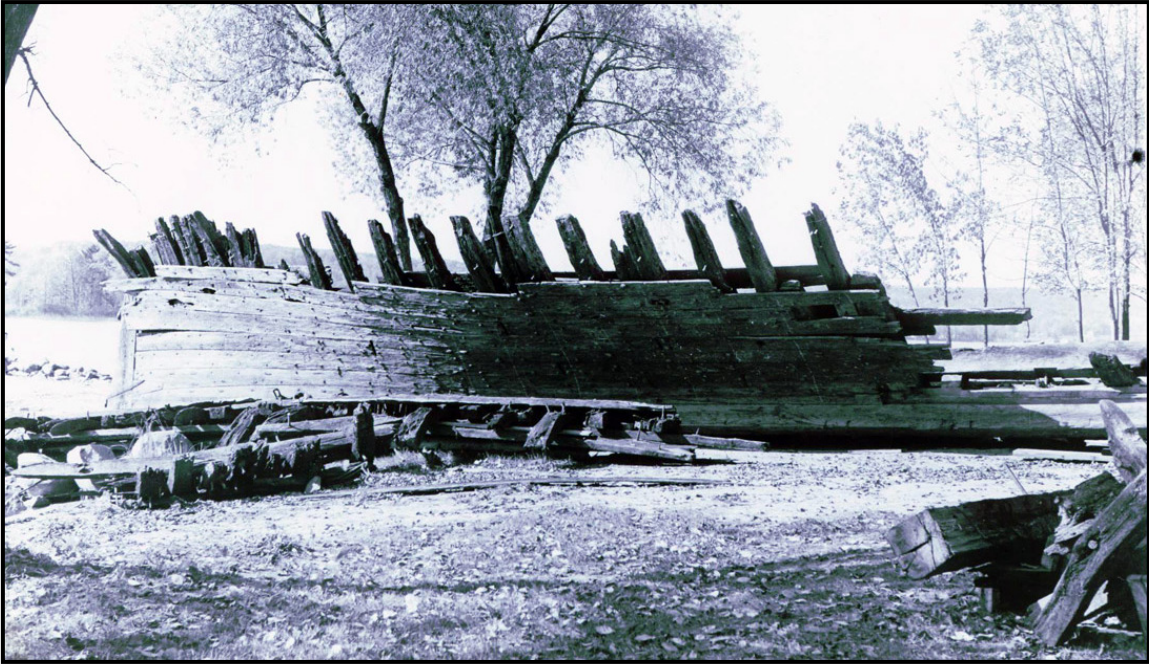

Figure 14: *Tecumseth* on the beach in Penetanguishene, 1953.
(Photo: John R. Stevens.)

Dimensions of the hull corresponded nearly exactly with a draft of two schooners constructed in 1815: *Tecumseth* and *Newash*.

The wreck was specifically identified as H.M. Schooner *Tecumseth*, by evidence of the rig. Three chainplates were recovered, indicating that the mast had three shrouds, precisely as shown in the drawing. In addition, though the foremast step had disappeared, bolts remained as testament to its location, which was far forward in the bow.²⁵¹ As *Newash* had been re-rigged as a brigantine and her foremast moved, the foremast step would not have been in the same location as that in the draft.

Thus identified, the skeletal vessel was labeled and displayed. Archaeological work and reconstruction continued at the former naval depot at Penetanguishene, and a museum called Discovery Harbor (Havre de la Découverte) was established on the grounds. The museum is home to two replica schooners, *Tecumseth* and *Bee*, which were reconstructed on the basis of archaeological and historical evidence and sail the waters of Penetanguishene Bay and beyond.

Early Publications

A photographer from *Life* magazine recorded the salvage in Penetanguishene, and an article appeared in the publication shortly afterwards. Soon afterwards, experts on Great Lakes vessels and other relevant topics, including historians C.H.J. Snider, Rowley Murphy and John R. Stevens, visited the hull, helped identify the wreck and published

scholarly works on the vessel. Snider featured the vessel in his “Schooner Days” column, published in the *Toronto Evening Telegram*.²⁵² Murphy published “Resurrection at Penetanguishene” in *Inland Seas* in 1954. He described the salvage and illustrated the evidence that allowed the remains to be identified as *Tecumseth*. Stevens prepared “The History of H.M. Armed Schooner *Tecumseth*.” In 1961, Stevens’ work was printed along with Rear Admiral H.F. Pullen’s “The March of the Seamen.”

Together, Stevens’ and Pullen’s work presents a detailed view of the vessels. Pullen concentrated his historical investigations on a naval uniform button found “between the planking and the ceiling” of the ship.²⁵³ Based on the particular design on the face of this button, Pullen traced it to the seamen who had traveled overland from New Brunswick to Kingston in 1814, possibly even Lieutenant Henry Kent himself. Stevens discussed the naval architecture of the schooner in his publication and drafted a number of views of the hull, including a body plan, midship section, inboard profile, planking expansion, a redrafting of Moore’s original construction design and a rigging plan.²⁵⁴

1970s Examination and Conservation Efforts

With the hull removed from Penetanguishene harbor, the archaeological remains of *Tecumseth* were available for study. The shelter of Discovery Harbour (Havre de la Découverte) protected the hull from the vandalism that had nearly destroyed *Tigress*, but the remains were still subjected to the elements. In October 1976 Charles Hett, a conservator, visited the wrecks in Penetanguishene. Hett examined the wooden remains

for signs of deterioration and sent five samples from *Tecumseth*'s hull to the Canadian Conservation Institute for analysis. As one might expect, Hett's report on the condition of the hulls was not particularly uplifting.

Both wrecks show the deterioration which is to be expected when wood from underwater burial is raised and allowed to dry without treatment. The deterioration is caused by the collapse of weakened cell walls when the water evaporates, and manifests itself in surface checking, warping, splitting; dimensional changes which will vary according to the cut of the wood as well as the type of wood. The damage describe above, and noticeable in varying degrees in the two shipwrecks can be considered irreversible.

In addition to the damages noted above there is continuing deterioration due largely to exposure to the elements. Both wrecks appear to be suffering from extensive deterioration due to micro organisms [sic]. Areas which retain moisture are most severely affected by this attack, notable the ribs. Considerable detritus has accumulated in the areas between the ribs and the planking, this detritus will retain moisture and will provide a continuing source of nutrition for micro organisms [sic].²⁵⁵

In addition to damage from microorganisms, Hett noticed that mechanical erosion had occurred while the hull was underwater, leaving the exterior surfaces weakened and the planking thin.²⁵⁶ The already-fragile hull was subject to additional damage from

environmental effects, and Hett recommended that some type of structure be built over both hulls, to protect them from further damage.

Hett found traces of preliminary conservation efforts:

Application of a commercial synthetic resin...[has] been made to the wood and metal parts...This material is visible as a glossy varnish in the iron, but is not visible on the surface of the wood. It is impossible to see whether this has achieved any useful purpose, unknown materials should not be employed for consolidation; in general they cause more problems than they solve.²⁵⁷

As a result of Hett's recommendations, both hulls were moved to a permanent display area on the grounds of the museum. The remains of *Tecumseth*, being more substantial and in better condition than that of *Tigress*, are more prominently displayed.

1997 – 1998 Archaeology

Although Jury's efforts in 1953 have made the remains of H.M. Schooner *Tecumseth* readily accessible for study by nautical archaeologists and the non-diving public alike, modern archaeological techniques are far superior to those used in the salvage. The hull certainly suffered tremendously in the dredge's jaws and evidence of the vessel's design and construction was obliterated. As nautical archaeologists can attest, much more information can be gathered about a shipwreck from studying it in situ, or by careful excavation and recording, than by simply removing the wreckage off the bottom. The

timbers have also suffered from a minimal amount of preservation treatment and continual exposure to environmental effects.

While studies undertaken shortly after Jury's salvage analyzed the remains and documented the overall history of the vessel, *Tecumseth* was not subject to modern archaeological study. As part of a comprehensive Texas A&M University program to investigate War of 1812-era shipwrecks in the Great Lakes, *Tecumseth* was visited by a team of student archaeologists, led by graduate student Erich Heinold, over two weeks in June 1997. The following summer *Newash* was surveyed in situ at the bottom of Penetanguishene harbor. Dimensions were taken of all accessible timbers, using measuring tapes and goniometers. Significant details of the hulls were drawn, to gain a better understanding of the precise methods used in constructing the two ships and wreck plans were made of the existing timbers of both hulls.

In addition to the archaeological study, Heinold searched for documentary evidence of the two vessels. Because the ships had served in the Royal Navy, many Admiralty records survive of their sailing careers and the events of the time; a number are currently held in the Library and Archives of Canada in Ottawa.

Although Heinold compiled a large amount of archival and field documentation and made detailed wreck plans (figs. 15 and 16), no final project or publication was created. Many of the field notes and copies of Admiralty documents made during the

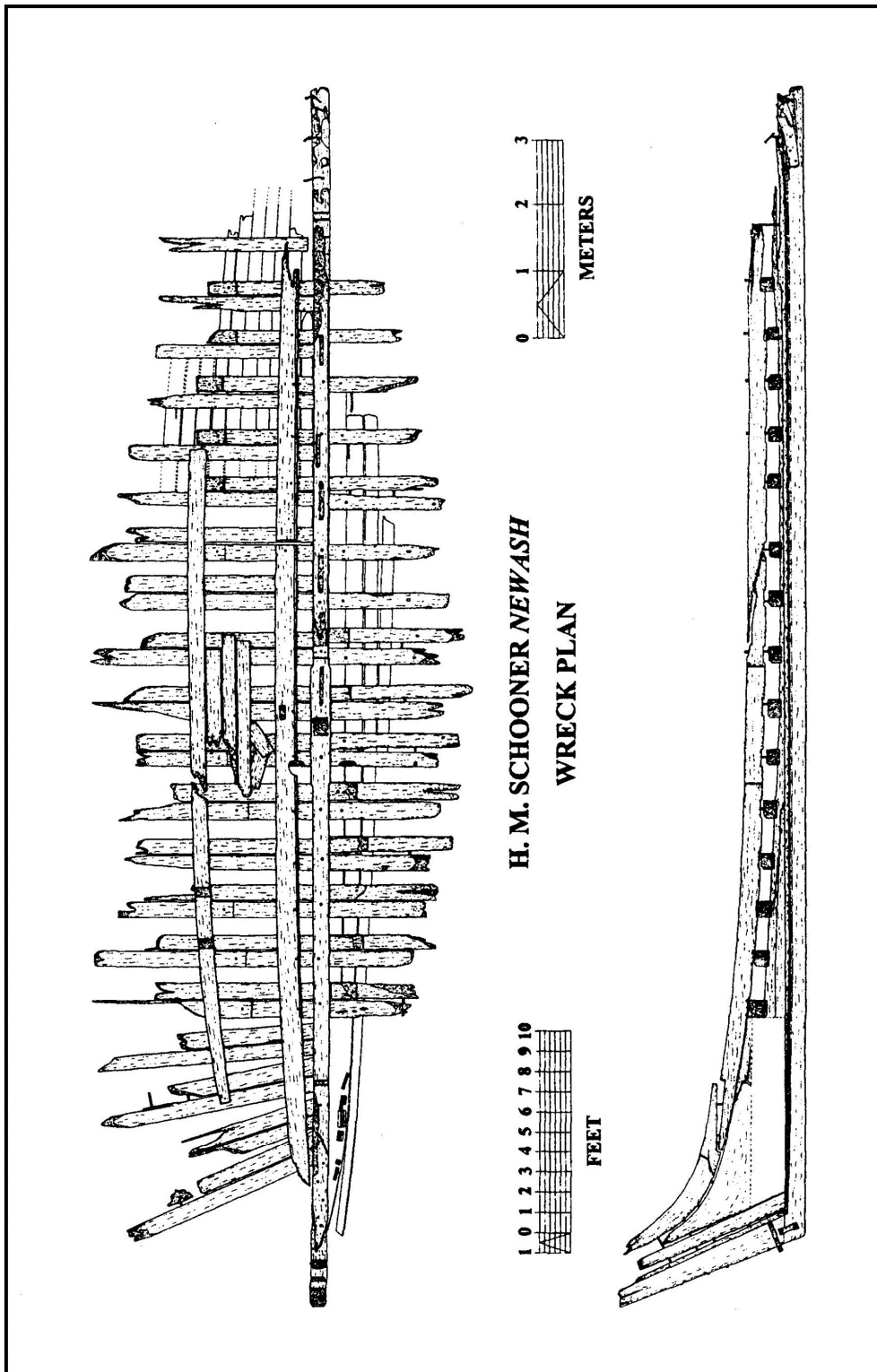

Figure 15: Wreck plan of *Newwash* remains. (Drawing: Erich Heinold, "H.M. Schooner *Newwash* Wreck Plan," Private Collection of Kevin J. Crisman.)

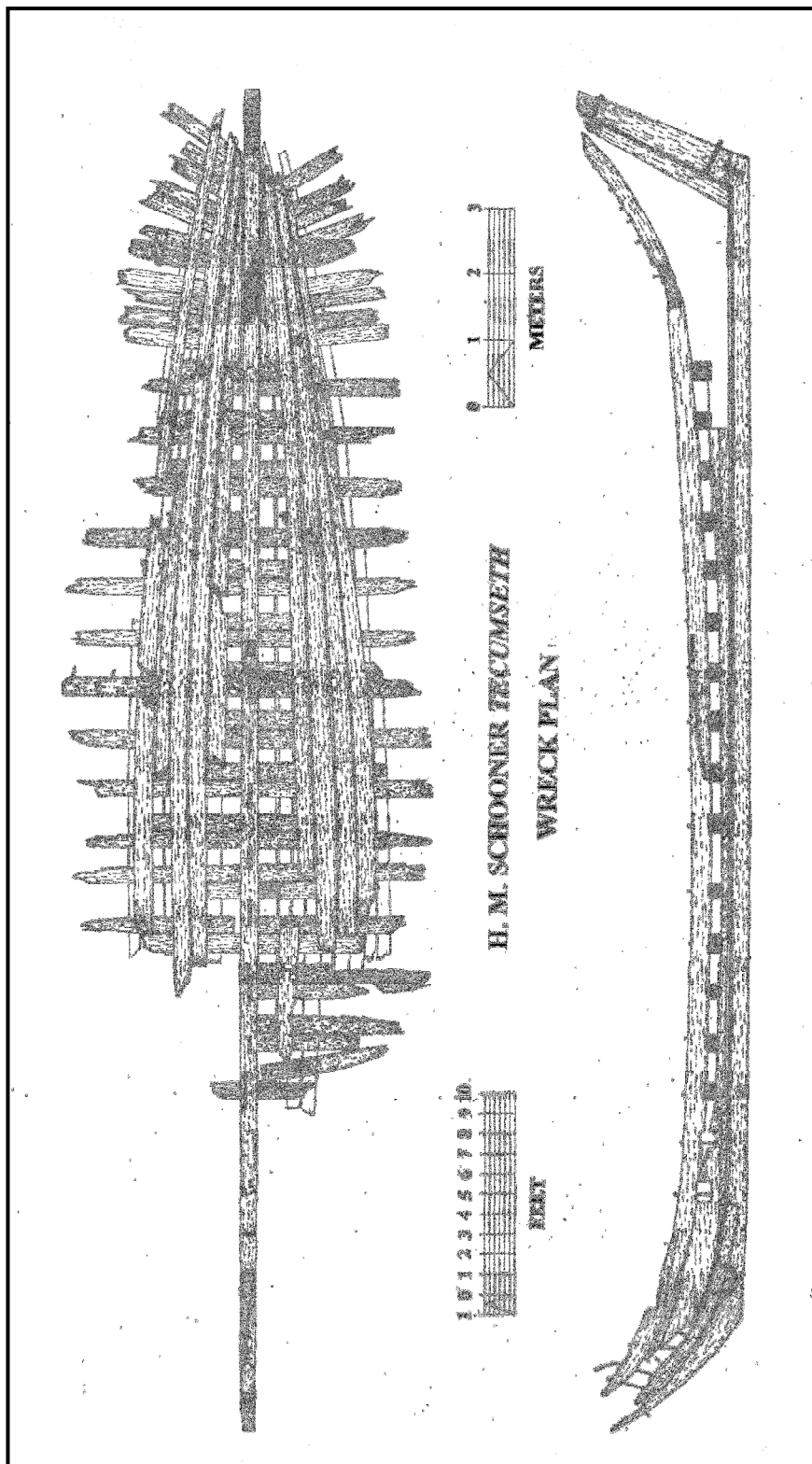

Figure 16. Wreck plan of *Tecumseth* remains. (Drawing: Erich Heinold, "H.M. Schooner *Tecumseth* Wreck Plan," Private Collection of Kevin J. Crisman.)

archaeological investigations are held in the collections of Dr. Kevin Crisman, professor of Nautical Archaeology at Texas A&M University.

2007 – 2008 Investigations

Because a final publication had yet to be created, additional research was conducted in preparation for the current project during the summers of 2007 and 2008. The author made two trips to Penetanguishene, documenting specific details of *Tecumseth* each time. Historical records in the Bayfield Room at the Penetanguishene Public Library were consulted, and microfilm and transcribed documents at the Library and Archives of Canada were analyzed for pertinent information.

While preparing this hull and rigging analysis, the author had the opportunity to discuss matters of history, shipbuilding and seamanship with captains of modern re-interpretations of contemporary vessels including the U.S. Brig *Niagara* and the topsail schooner *Pride of Baltimore II*. Both vessels are reconstructions of War of 1812-era ships, and the captains contributed insights into potential sailing characteristics of contemporary sailing vessels.

CHAPTER X

ARCHAEOLOGICAL EVIDENCE OF THE SCHOONERS' CONSTRUCTION

The remains of *Tecumseth* have been examined and recorded on several occasions since her removal from Penetanguishene Bay. In spite of the dry rot which has affected the hull since Jury's salvage, the remains kept their form remarkably well. The remaining portions comprised the lowest elements of the hull, including parts of the keel, keelson, frames, outer planking, interior or ceiling planking, sternpost and stem. Because the ceiling planking was still in place during archaeological investigations in 1997-98 and 2007-08, some of the details of the hull construction were inaccessible. Some other features of the remains were obscured due to their location within the structure housing hull. The two schooners were built using feet and inches, these units have been used to describe the hull features. Metric equivalents are also provided.

Newash was examined and documented in 1998; the remains were submerged in approximately 6 to 12 feet (1.83 m to 3.66 m) of water, listing to the port side.

Archaeological permits granted to Heinold and his team did not allow disturbance of any sediments on or around the remains of *Newash*, limiting the survey to those timbers that remained exposed above the harbor bottom. Zebra mussels covered some wreck features, particularly iron fasteners, obscuring details as well. The wreck site was surveyed and timbers were documented over approximately two weeks in July 1998.

The following discussion of the archaeology of both ships utilized information, both published and unpublished, observed by other archaeologists, as well as that gathered in the course of this project. The projects undertaken in the late 1990s and 2000s were somewhat hampered by overlying hull timbers and sediments, which obscured some hull features. Nevertheless, the details of both wrecks allow a glimpse into the construction features of the vessels.

Keels and Posts

Cutting and shaping the keel is the first step in assembling a ship. A keel was made of one or more lengths of strong, usually straight-grained timber. British shipwrights typically chose oak for the keels of their vessels. For larger ships, it could be difficult, if not impossible, to find a single oak large enough to yield an entire keel, so smaller pieces were often scarfed, or joined, together to form the keel. In British ships it was typical to build a keel from several pieces of wood, each no more than 25 feet (7.62 m) long.²⁵⁸

A notch or rabbet was carved in the outboard sides of the keel, near the top. The lowest strake of planking, called the garboard, fit into the rabbet to ensure a tight joint between the keel and the strakes on either side. The keel's forward end was joined to the stem assembly that, in British ships of the 19th century, was comprised of several pieces of wood (fig. 17). The stem abutted the keel and the elaborate joint between them was called the "boxing." The stem was angled, or raked, forward and upward. Attached to

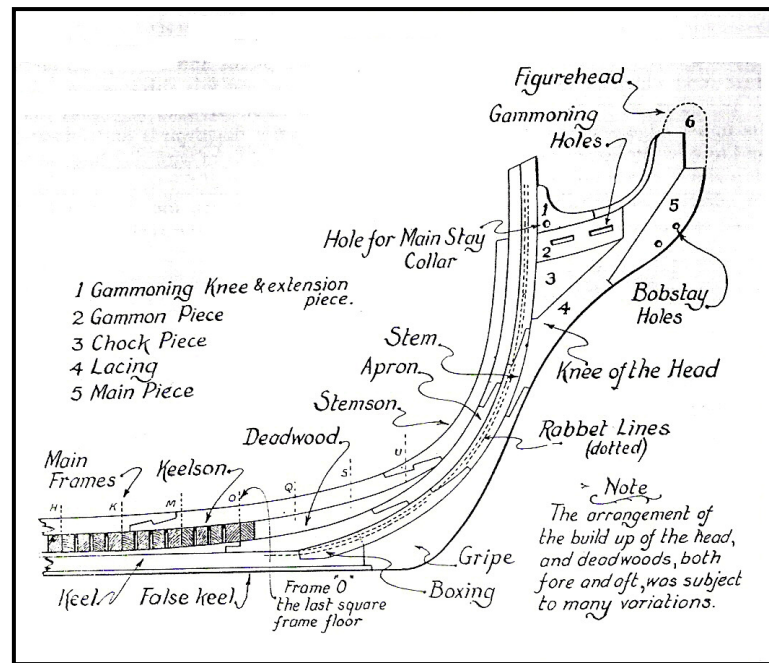

Figure 17: Bow assembly of large contemporary vessels.
(Detail from C. Nepean Longridge, *Anatomy of Nelson's Ships*, 14.)

the stem and also to the keel was a timber called the “gripe.” The gripe projected downward from the stem, a feature thought to increase a ship’s windward ability.²⁵⁹ The sternpost was attached at the after end of the keel, often at an angle. A mortise cut into the top of the keel accommodated a corresponding tenon in the bottom of the sternpost. The rakes of the sternpost and stem extended the vessel’s overall length.

Tecumseth’s keel was made of one piece of white oak²⁶⁰ and measured 55 feet 9.75 inches (17.02 m) long.²⁶¹ It was 10 inches (25.41 cm) sided, with a molded depth of 13 inches (33.03 cm). Eleven inches (27.95 cm) of the keel projected below the rabbet. *Newash*’s keel was only exposed enough to obtain adequate measurements near the bow. Here, the sided dimensions ranged from 8 inches (20.32 cm) to 10 inches (25.41 cm),

with a molded dimension ranging from 13.75 inches (34.93 cm) to 16.5 inches (41.91 cm). Many gaps and grooves in this timber were filled in with sediment.

A false keel may have been attached underneath the keel, both to add lateral resistance and to serve as a sacrificial piece of wood, which would have protected the keel should the vessel run aground.²⁶² No false keel survives, but archaeologists observed two grooves or channels along the bottom of *Newash*'s keel, which may testify to its existence. Field notes from the 1998 season indicated that several of the iron bolts found in *Newash*'s keel extended beyond the range of the keel, and may have been used to attach a false keel, which had broken or eroded away.

Tecumseth's stem was attached to the keel with a boxing scarf,²⁶³ a complex joint that indicates the significance of the union between the keel and stem (fig. 18). Without a strong connection at this place, the hull's structural integrity might have been compromised. With the overlying timbers still in place, it was difficult to identify *Tecumseth*'s boxing scarf. Viewed from the side, a boxing scarf looks like a simple

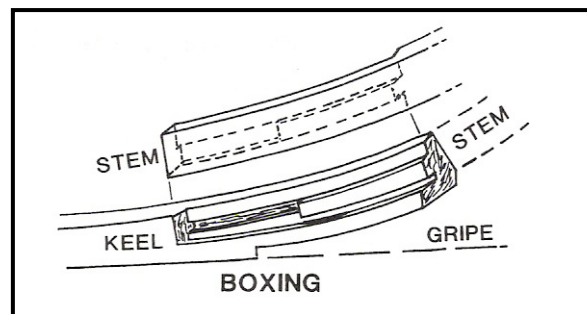

Figure 18: Boxing scarf. (Detail from J. Richard Steffy, *Wooden Ship Building*, 292, fig. G-11b.)

timber butt joint. By comparing measurements taken from both faces of the keel, along with a photo taken by John R. Stevens, (fig. 19) it became apparent that the port and starboard “timber butts” were in different places.²⁶⁴ Stevens also noted that “[t]he boxing scarph uniting the stem to the keel was, relative to the [original construction] plan, shifted forward 6 inches [15.24 cm].”²⁶⁵ This may have been done to make the best use of available timber. Similar measurements taken of *Newash*’s keel and stem indicate that a boxing scarf was utilized in construction of that vessel as well.

Tecumseth’s stem only partially survived (fig. 20). It measured 13 feet 4 inches (4.07 m)²⁶⁶ along its length and was cut from naturally curved compass timber. The gripe was attached to the keel forward of and below the stem. Field notes from the 1998 season

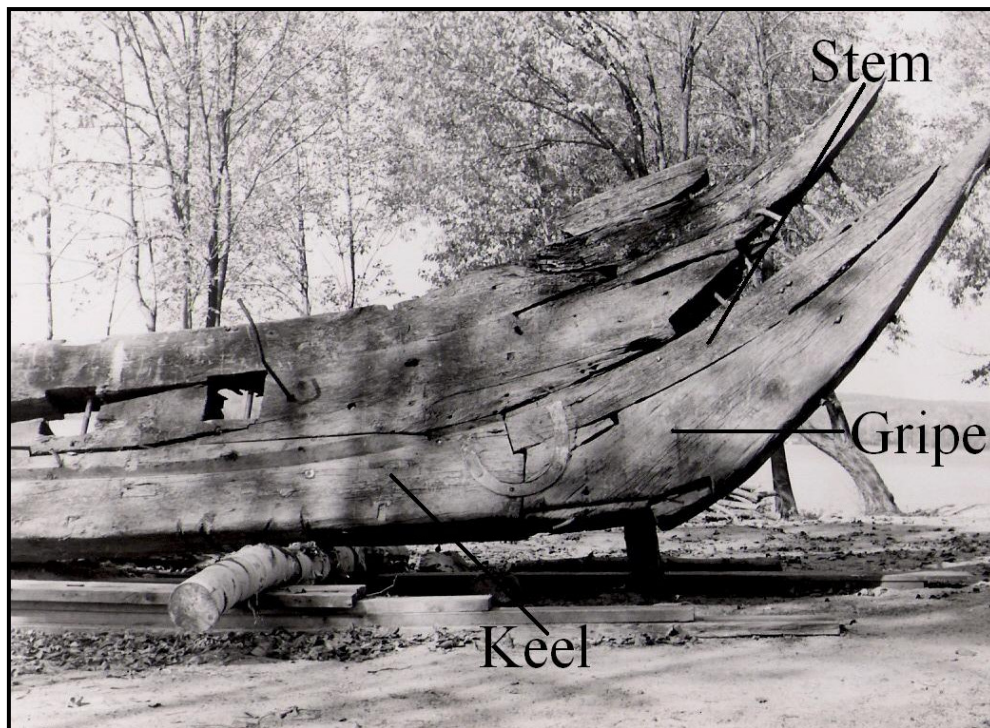

Figure 19: Photo of *Tecumseth*’s bow assembly, starboard face.
(Photo: John R. Stevens.)

indicate that a groove was cut into the forward end of the keel, giving it a “U” shape.²⁶⁷ This groove may have accommodated a tenon in the after end of the gripe. Unlike the stem, *Tecumseth*’s gripe was not cut from compass timber but instead shaped from straight-grained timber, with the grain running at an angle of approximately 135° to the keel. Only the lower 8 feet 9 inches (2.67 m)²⁶⁸ of *Tecumseth*’s gripe remained, and it was 10.00 inches (27.94 cm) sided and 18.25 inches (46.37 cm) molded at its greatest depth. The total projection of the stem and gripe below and forward of the rabbet is 25.00 inches (63.52 cm). The gripe was somewhat fuller than the construction draft indicated, possibly as a result of the shift in the boxing scarf.²⁶⁹ As previously discussed, the projection of the gripe increased the ship’s lateral resistance and her ability to sail close to the wind.

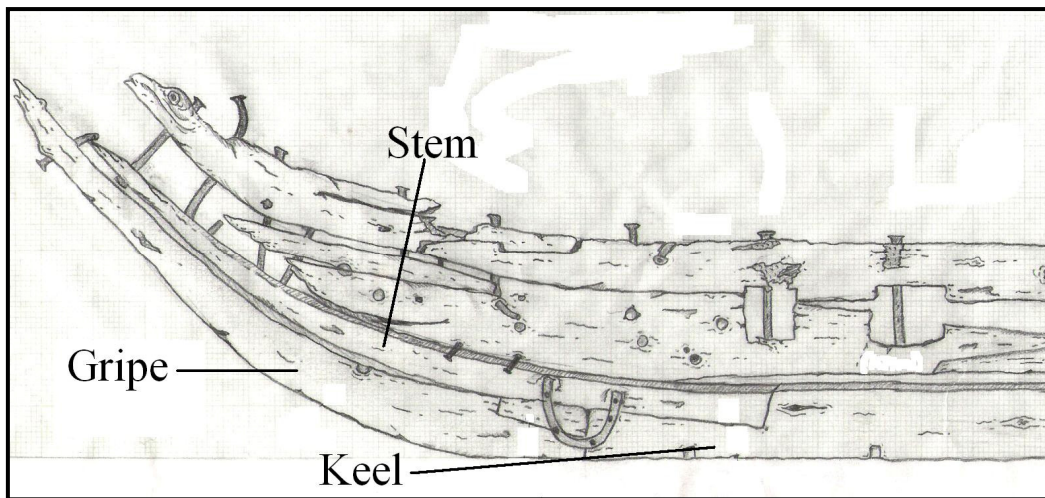

Figure 20: Drawing of *Tecumseth*’s bow assembly, port face. Not to scale. (Drawing: Bryan Atchison, “Stem Assembly (Port),” 19 June 1997. Private Collection of Kevin J. Crisman.)

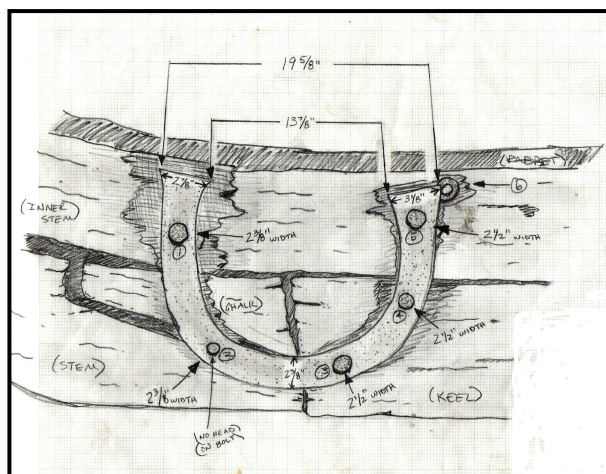

Figure 21: Drawing of *Tecumseth's* port horseshoe plate. Not to scale. (Drawing: Bryan Atchison, "Horseshoe Plate (Port)," 23 June 1997. Private Collection of Kevin J. Crisman.)

The joint connecting the keel and gripe was reinforced with two 0.50-inch thick (1.27 cm) iron horseshoe plates, placed on either side of the keel (fig. 21). The upward arms of the plates were bolted to the stem, while the lower "U" of the plate connected the gripe and keel, and a chock fitted between the two. Five round bolts, of varying diameters²⁷⁰ were driven through the timbers, from both sides, to secure the plates to the keel-stem-gripe assembly. The portside plate also featured chisel marks in the shape of an "M" with a "k" (fig. 22). The blacksmith who forged the plate may have made this mark, identifying his work. The starboard plate was difficult to reach in 2007 and 2008, due to surrounding disarticulated timbers, and it was not possible to tell if a similar marking existed on this plate.

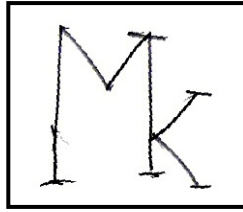

Figure 22:
Maker's mark on
Tecumseth's port
horseshoe plate.

The joints of the stem and keel and gripe and keel are offset from each other, so that no joint lay directly over another. For example, the boxing scarf that joins *Tecumseth's* keel and stem was 47.25 inches (1.20 m) aft of the mortise and tenon that joined the keel and gripe. The distance between scarfs is called “shift,” and the practice of offsetting scarfs is called “giving shift.”²⁷¹ Giving shift allows adjacent pieces to bolster the weaker point of a scarf.

At the after end of the vessel, the sternpost and keel met at an angle of 117°. Two iron fish plates that reinforced the mortise and tenon joint were attached on either side of the sternpost and keel by six round bolts. The plates were approximately 12.63 inches (32.08 cm) long and 5.00 inches (12.70 cm) at their widest point.²⁷² The starboard plate was 0.38 inches (0.95 cm) thick in the middle, but tapered to 0.25 inch (0.64 cm) thick at the ends. The bolts were 0.88 inch (2.23 cm) in diameter, with 1.50 inch (3.81 cm) heads. Once again, the bolts were driven from both sides, in an alternating pattern. The rabbet of the keel continued up the forward corners of the sternpost. Here, the keel

projected 9.50 inches (24.14 cm) below the rabbet, and the sternpost projected 15.75 inches (40.02 cm) aft of the rabbet.

Like the keel-stem-gripe assembly, the stern assembly was an important feature on the schooners and involved detailed construction and a number of timbers. The original construction draft of the vessels shows that the assembly was reinforced by an inner sternpost and stern knee. Ceiling planking obscured these features on *Tecumseth*, making it impossible to obtain measurements and thoroughly record these details. Field notes from the 1998 investigations did not yield insights into the features on *Newash*, possibly because the features were covered with sediments or otherwise obscured (fig. 23).

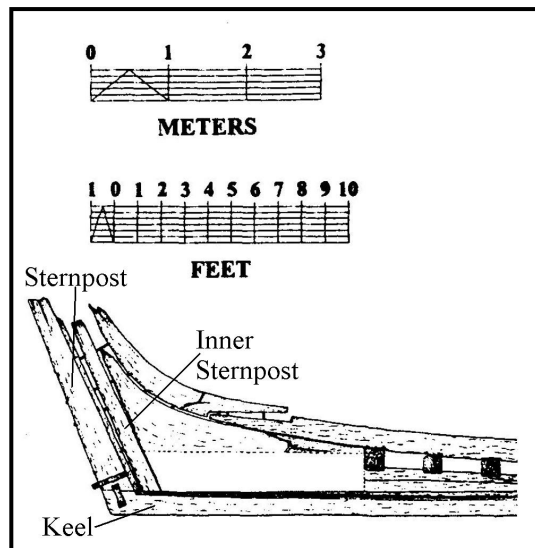

Figure 23: Stern assembly of *Newash*.
 (Drawing: Erich Heinold, "H.M. Schooner *Newash* Wreck Plan," Private Collection of Kevin J. Crisman.)

The after face of the sternpost was beveled on each side to allow the rudder, which was hung by pintles and gudgeons, to swing freely. Two of *Tecumseth's* gudgeons survived, bolted to the sternpost and adjacent planking. Both gudgeons were placed at a 90° angle to the sternpost's after face. The lower gudgeon embraced the sternpost with arms that were 24.75 inches (62.88 cm) in length, and secured with four round bolts driven from alternating sides. The gudgeon arms were 0.25 inches (0.64 cm) thick at their forward ends and 0.50 inches (1.27 cm) thick at the aft face of the sternpost. The upper gudgeon was much shorter than the lower one, with arms measuring 11 inches (27.95 cm) long. The arms were attached to the sternpost with three round bolts, of 0.88-inch (2.22 cm) diameter. The upper gudgeon was slightly thicker, measuring 0.38 inches (0.95 cm) at its forward end and 0.50 inch (1.27 cm) at the aft face of the sternpost. The gudgeons were shaped to accommodate a 2-inch (5.08 cm) diameter pintle, which was attached to the rudder. To support the weight of the rudder, both gudgeons were thicker around the hole, measuring nearly 1 inch (2.54 cm) in thickness. *Tecumseth's* gudgeons were placed 6 feet 2 inches (1.88 m) apart. The site plan of *Newash* shows only one gudgeon, since the extant remains of the sternpost are much shorter than *Tecumseth's* surviving sternpost.

Deadwood

After the keel and posts were raised, frames could be shaped, assembled and attached. For increased strength, frames were sandwiched between two strong pieces of wood. One such piece, called the rising deadwood, was placed on top of the keel, and notches

were cut into its upper surface to receive frames. The rising deadwood was not very thick, only measuring 3 inches (7.62 cm) molded near the bow, where it was accessible. Deadwood pieces were also placed in the bow and stern, both to strengthen the stem and sternpost assemblies, and to offer better points of attachment for the narrow frames that appear there.

The deadwood was shaped very precisely, so that it would lie in contact with the adjacent pieces. When a timber was shaped in this way, it is called “faying.”²⁷³ In Royal Navy ships of the Napoleonic era, an inner stem was fayed to fit directly atop the stem. *Tecumseth*’s stem assembly was also reinforced with an apron, at the forward end of the rising deadwood. The apron, stem, and other deadwood pieces were cut and trimmed to fit closely to each other, and bolted securely together. Likewise, the reinforcing pieces of the stern assembly, the inner sternpost and stern knee, were fayed to fit tightly with one another. This created a solid mass of timber that strengthened these critical areas of the hulls.

Frames

After the keels and posts were raised, frames were cut, shaped and assembled from several short pieces of wood. Each square frame was made with a single timber that crossed over the keel, called a floor, and a series of futtocks extending up the sides of the hull. On *Tecumseth* and *Newash*, the floors were set into notches cut in the rising deadwoods atop the keels with the lowest, or first, futtocks placed on the forward or after

side of the floors. On the two hulls the first futtocks were placed aft of the floors forward of the midship frame, the widest in the hull, while in the after part the first futtocks were placed forward of the floors. The rising deadwood was not notched for the first futtocks; rather, the heels of the first futtocks were shaped to fit over one side of the deadwood. The port and starboard first futtocks met at the vessels' centerlines, but did not cross them.

Because the interior and exterior planking remained intact, examining *Tecumseth's* frames and futtocks proved difficult. In some areas, the planking had been eroded or torn away and it was possible to measure either the frames themselves or the notches cut to receive them. From these, it was possible to obtain averages for the dimensions of the frames and futtocks. They averaged 9.10 inches (23.12 cm) molded and 10.00 inches (25.41 cm) sided.²⁷⁴ Early observations of *Tecumseth* noted that the frames were placed on 30-inch (79.22 cm) centers.²⁷⁵ Field notes of Heinold's observations indicate that there were 16 full, or square, frames along the length of the vessel, with an indeterminate number of cant frames in the bow and half-frames in the stern.²⁷⁶ A sample taken from one "rib" in 1976 was identified as white oak.²⁷⁷ John R. Stevens, who examined the ship in the 1950s, noted that some of the frames were made of pine.²⁷⁸ It is possible that these pine frame timbers were replacements added when the schooner was refitted in 1819.

Second, third and fourth futtocks were placed at the ends of the floors and first futtocks to complete the rest of the frames. From the site plan of *Newash*, it is evident that the floors were roughly the same length. To avoid a situation where the bottom part of the vessel was not attached to the top, scarfs between floors and futtocks gave shift to each other. The floors and futtocks were attached to each other with iron spikes and treenails.

Keelsons, Stemsons and Sternsons

The floors were secured in place by the addition of a keelson, a longitudinal member lying on top of the keel and frames. Notches were cut into the underside of the keelson to fit over the floors. The forward end of the keelson was scarfed to another longitudinal member called a stemson while a sternson was scarfed to its after end.

The sternson, like most of the stern assembly, was not visible on *Tecumseth* because of surviving ceiling planking. The keelson was evident, and was recorded during Heinold's 1997 field season, and again in 2008. It measured 9.25 inches (23.50 cm) sided, had an average molded depth of 11.00 inches (27.95 cm) and was fastened to the floors with 1.13-inch (2.86 cm) diameter iron bolts. *Newash's* keelson was made of two separate timbers; hook scarfs were used to join the pieces of the keelsons on both vessels (fig. 24). A sample taken from *Tecumseth's* keelson was determined to be white oak.²⁷⁹

Tecumseth's stemson was made of compass timber, with the grain running in a similar direction to the stem. A plan view of the stemson shows that the timber used did not have a smooth longitudinal grain (fig. 25); the use of this timber may demonstrate the

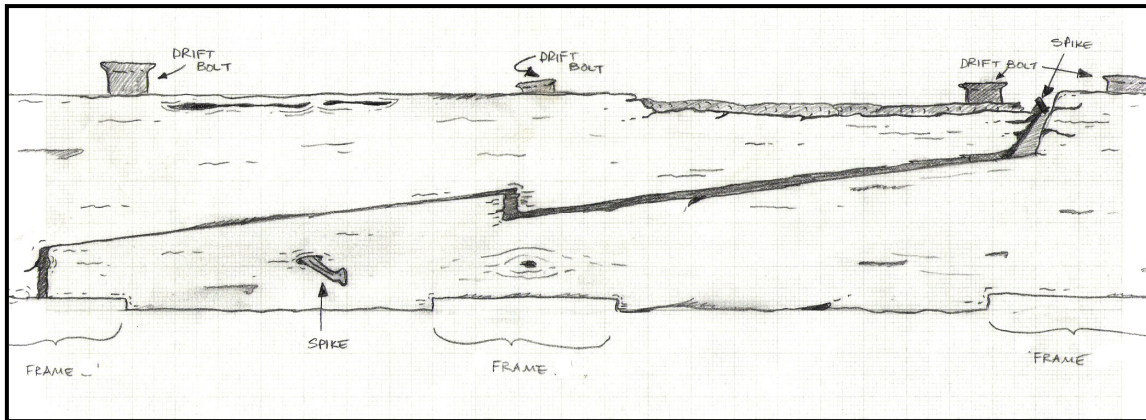

Figure 24: Hook scarf in *Tecumseth*'s keelson. Not to scale. (Drawing: Erich Heinold and Bryan Atchison, "Keelson Scarf (Port Side View)," 24 June 1997. Private Collection of Kevin J. Crisman.)

brief time in which the vessels were built, or the quality of locally-grown compass timber available to the shipwrights in 1815.

Mast Steps

The stemson-keelson-sternson assembly supported the mast steps, which in turn supported the masts. No evidence survives on either wreck of the foremast steps. The mainmast steps on both *Newash* and *Tecumseth* do survive, however, in the form of mortises cut into the top of the keelson. On the latter vessel, the mortise was found just 8.63 inches (21.91 cm) aft of a hook scarf that joins two pieces of *Tecumseth*'s keelson.

The mortise in *Tecumseth*'s keelson (fig. 26) measured 6.69 inches (16.99 cm) wide and 9.50 inches (24.14 cm) long. At the forward edge of the mortise, the keelson itself measured 9.63 inches (24.45 cm) sided. The after surface of the mortise was cut at an angle, which was necessary to provide support for the raked mast. Extensive dry rot

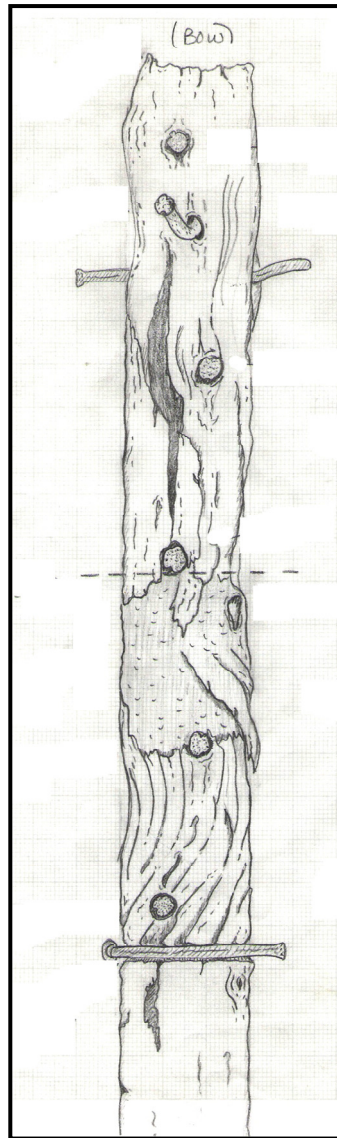

Figure 25: Plan view of *Tecumseth's* stemson, showing the convoluted grain of the wood. Not to scale. (Drawing: Bryan Atchison, "HMS *Tecumseth*, Keelson Top View (Stem)," 17 June 1997. Private Collection of Kevin J. Crisman.)

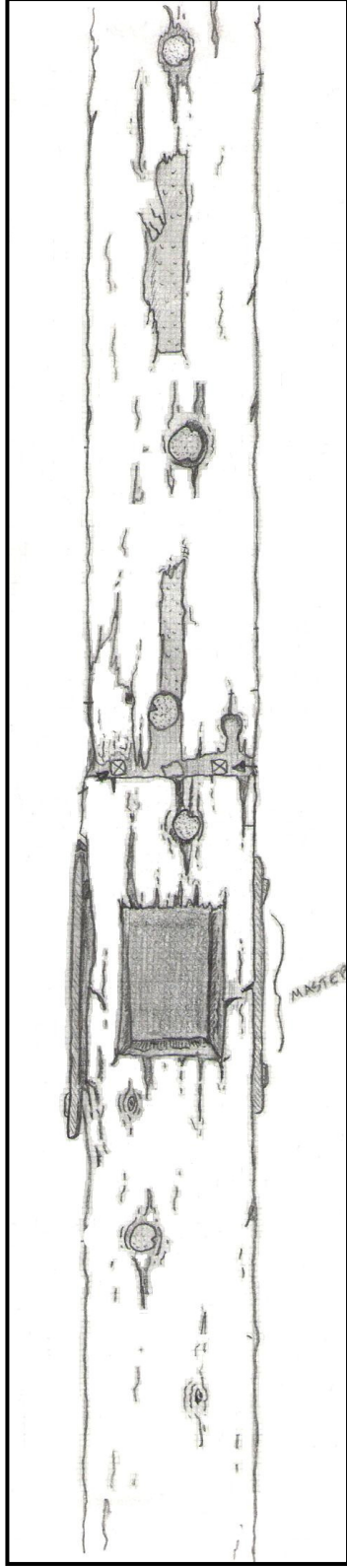

Figure 26: Drawing of *Tecumseth*'s main mast step. Not to scale. (Drawing: Bryan Atchison, "HMS *Tecumseth*, Keelson Top View, 1 of 2," 17 June 1997. Private Collection of Kevin J. Crisman.)

throughout the keelson gave its upper surface a soft, spongy texture and prevented the depth of the mast step from being measured during 2008 investigations.

Movement of the mast placed strain on its step and on *Tecumseth* the mast step was strengthened with the addition of an iron plate on either side of the mast step. The port plate measured 18 inches (45.73 cm) long, 2 inches (5.08 cm) wide and lay nearly flush with the side of the keelson, rendering it impossible to measure its thickness. The starboard plate was of the same dimensions. Two bolts were driven through the keelson to secure the iron plates in place. One bolt was placed forward of the step while the other was aft, and the bolts were driven from alternating sides.

Field notes and photographs taken during the 1998 season show that *Newash*'s mast step was slightly different from *Tecumseth*'s. *Tecumseth*'s keelson remained a consistent width along its entire length while *Newash*'s keelson is slightly enlarged at the point where the mortise was cut for the mainmast step (fig. 27). The enlarged section of keelson measured 5 feet 8.25 inches (1.73 m) long and 11.50 inches (29.22 cm) sided. The mortise for the heel of the mast measured 8.50 inches (21.60 cm) wide and 10.25 inches (26.04 cm) long. At its forward end, the mortise was 4.75 inches (12.07 cm) deep, increasing to 5.00 inches (12.70 cm) deep at its after end. There was no evidence of iron plates reinforcing the sides of the mortise on the underwater wreck, suggesting that none were fitted. The difference in mast step details may indicate a shortage of ironwork during construction, or may be evidence of *Tecumseth*'s refit in 1819.

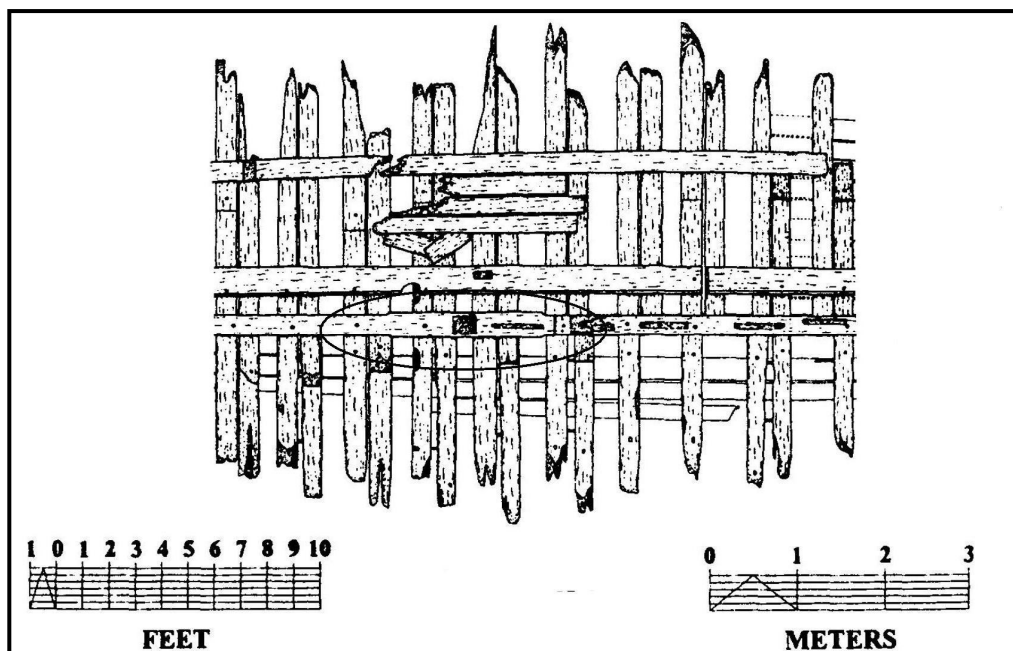

Figure 27: Detail of *Newwash*'s main mast step, circled. (Detail from Erich Heinold, "H.M. Schooner *Newwash* Wreck Plan," Private Collection of Kevin J. Crisman.)

Mast Section

A single fragment of a mast was found in the display with the hull of *Tecumseth*. The piece of mast was 10 feet 11 inches (3.33 m) long, with a maximum diameter of 11.11 inches (28.23 cm). The mast was roughly hewn, with visible hatchet marks²⁸⁰, and a crude tenon at its heel. The tenon measured 8.56 inches (21.75 cm) at its maximum length and 6.00 inches (15.24 cm) wide. What was presumed to be the after edge was chamfered at an angle of 10°, evidence of a slight rake.

The difference between the tenon at the heel of this mast fragment and the size of the mortise in the keelson could be explained by wear and deterioration over the course of the vessel's life. It is also possible that the tenon was deliberately made smaller than the

mortise and was wedged into place with small pieces of wood. The small diameter of the mast piece, however, raises some questions. If it belonged to *Newash* or *Tecumseth*, it was far smaller than either of the masts shown in Robert Moore's construction draft. Moore shows a 19-inch (48.27 cm) diameter mast. It is true that masts often taper below the mast partners, which support a mast at the deck level. The length of the surviving mast piece, at nearly 11 feet (3.35 m), would reach beyond the mast partners of either fore or main masts on *Newash* and *Tecumseth*. It is far more likely that this section of mast is a part of the disarticulated remains of the schooner *Surprize* (ex-*Tigress*), which share the small display structure with the hull of *Tecumseth*.

Pump Wells and Limber Holes

Inevitably, wooden ships leak. Though wood expands when it is saturated, tightening planking seams, water still seeps into the hull. This water typically remains in the lowest parts of the hull, and is called bilge water. Excess bilge water is expelled by the ship's pumps. Traditionally, such pumps were located near the main mast step. Two pump wells were found on both *Tecumseth* and *Newash*, just aft and slightly outboard of the main mast steps. The wells were for the placement of pump tubes, used to expel excess bilge water from within the hull. The pump wells, as measured on the remains of *Newash*, were 11 and 11.25 inches (27.95 cm and 28.58 cm) in diameter, and were partially cut from the forward edge of one of the floors.

To facilitate pumping, limber holes were cut into the bottoms of all floors and first futtocks, with one limber hole on either side of the keel. These holes allowed bilge water to travel freely throughout the vessel, allowing the pumps to drain water from the entire ship. On *Newash* and *Tecumseth*, the limber holes were roughly-cut, triangular notches located just outboard of the rising deadwood. Limber holes were cut before a floor or futtock was placed on the keel; at the very latest, before the hull is planked. Without limber holes, bilge water would have been trapped between floors and futtocks and become a stagnant breeding ground for organisms and rot.

Clamps, Deck Beams, Waterways and Wales

After the frames were assembled, a clamp was placed just below the level of the deck. The clamp served two functions. It secured and bound the frames together along their interior sides, strengthening the hull above the waterline,²⁸¹ and supported deck beams. Typically, the deck and sides of the hull were united and stiffened by the addition of internal knees, which formed an elbow-joint below the deck. No knees were found in the remains of the vessels.²⁸²

The deck beams were also supported by a number of stanchions, which were seated atop the keelson. *Tecumseth's* extant keelson showed impressions or shallow mortises for these stanchions, though the timbers themselves did not survive. The site plan of *Newash's* remains shows mortises for six stanchions atop the keelson, forward of the main mast step; there are no traces of stanchions aft of the main mast step. John R.

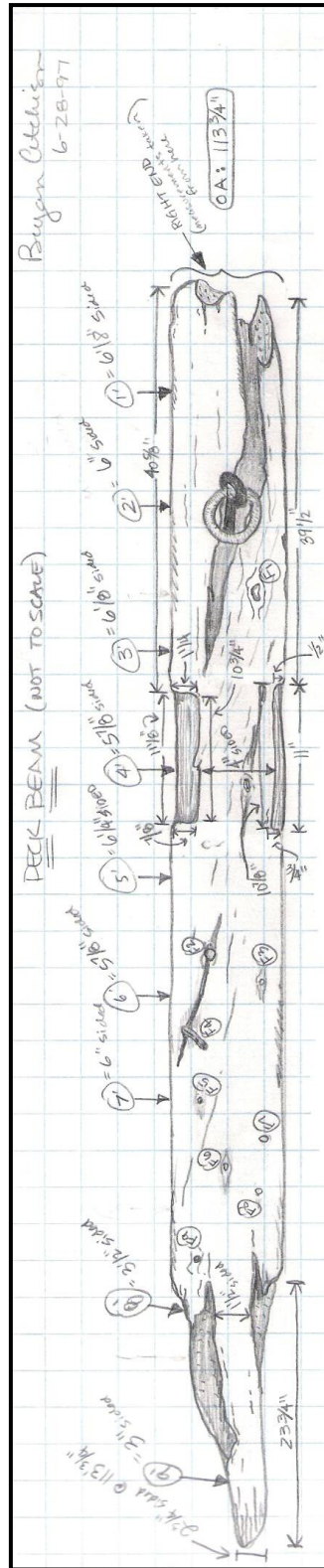

Figure 28: Plan view of *Tecumseth's* deck beam. Not to scale. (Drawing: Bryan Atchison, "Deck Beam (Not to Scale)," 28 June 1997. Private Collection of Kevin J. Crisman.)

Stevens observed that all of the deck beams between the masts were supported by stanchions, except three. He proposed that the stanchions were evenly spaced except for a gap where a hatch leading into the main cargo hold was placed. The beams adjacent to this hatch may have required extra reinforcing, particularly since the two long guns were placed on this area of the deck. Stevens also noted that the stanchions were “inclined so that they would be perpendicular with the line of flotation.”²⁸³ To place the stanchions, Stevens observed that “after their heads had been fitted in mortises in the [deck] beams, [the stanchions] were driven into their steps through scores entering from abaft. The scores were plugged to prevent the pillars from working out. One of the fillers was still in position when I [Stevens] examined the wreck.”²⁸⁴

Several timbers on both wrecks have become dissociated from the rest of the hull. It is often difficult to identify these detached timbers, as many factors can mask their original purpose. One disarticulated timber was also found with the remains of *Tecumseth* during the 1997 season. Roughly 6.25 inches (15.88 cm) square and nearly 9 feet 6 inches (2.90 m) long, the timber was identified as a deck beam (fig. 28). The timber had two notches, both 11.00 inches (27.95 cm) wide; one measured 1.25 inches (3.18 cm) deep and the other 0.75 inches (1.91 cm) deep. These notches may have been cut for carlings, which ran longitudinally between deck beams and added strength and support to the deck planking. The timber contained six spike holes and partial remains of five spikes. A ring bolt and ring, was also found, attached to the beam.²⁸⁵

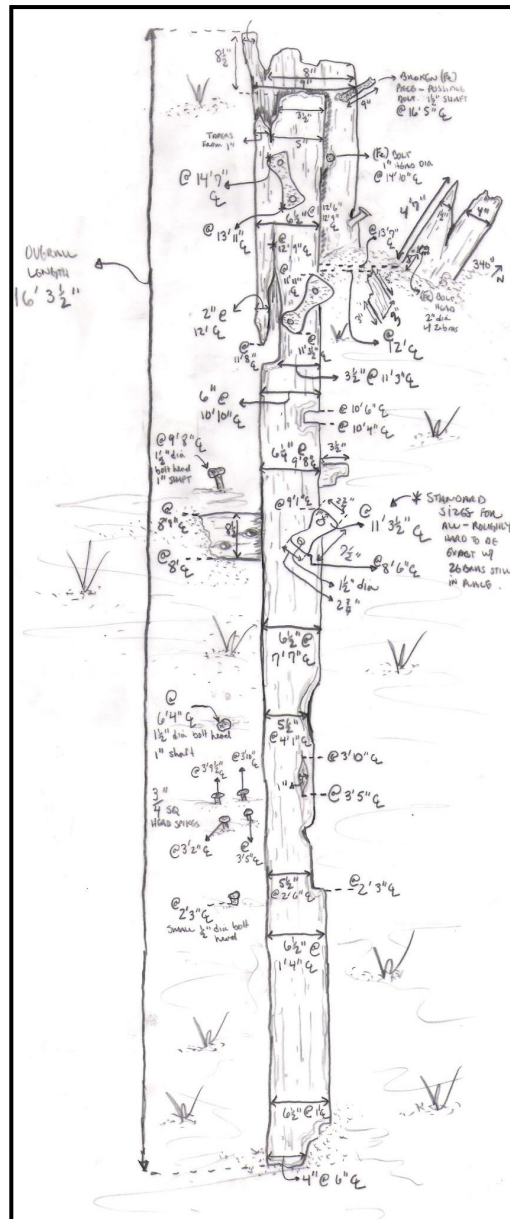

Figure 29: Drawing of disarticulated timber from *Newash*, identified as a clamp/waterway but possibly an exterior plank with chainplates attached. Not to scale. (Drawing: Eric B. Emery, “*Newash* Project, Clamp/Waterway Top View,” 15 – 16 July 1998. Private Collection of Kevin J. Crisman.)

Another dissociated timber was found underwater near *Newash* in 1998 and identified as part of a clamp/waterway assembly. This identification may not be correct. As mentioned, the clamp joined the upper ends of the frames and supported deck beams; atop the deck beams, deck planking was placed and a waterway ran along the edges of the hull. The timber was partially buried in sediments, and consisted of fragments of two separate timbers that remained connected by several bolts. The lower piece was difficult to record due to the overlying sediments, but a top view of the upper timber was produced (fig. 29). The timber measured 16 feet 3.50 inches (4.97 m) long, 6.50 inches (16.51 cm) wide and 2.00 inches (5.08 cm) thick at its widest point.²⁸⁶ Several iron bolts survive in conjunction with this piece; at least three have shaft diameters of 1 inch (2.54 cm). The disarticulated timbers may not be a clamp and waterway.

Observations made in 1953 noted that the interior of the vessel featured no knees, which would have served as internal bracing pieces. Without knees, it is likely that the shipwrights would have stiffened the shell of the hull with an enlarged clamp and waterway assembly, probably with timbers larger than 2 inches (5.08 cm) thick. In a reconstruction drawing of the midship section of *Tecumseth*, John R. Stevens illustrated such an assembly, with an enlarged clamp and waterway but no internal knees (fig. 30).

In addition, three figure-of-eight shaped pieces are shown in the top view of the disarticulated timber. The pieces appear to have one hole in either side. Unfortunately, no mention of the material of these pieces was made in the field notes. The

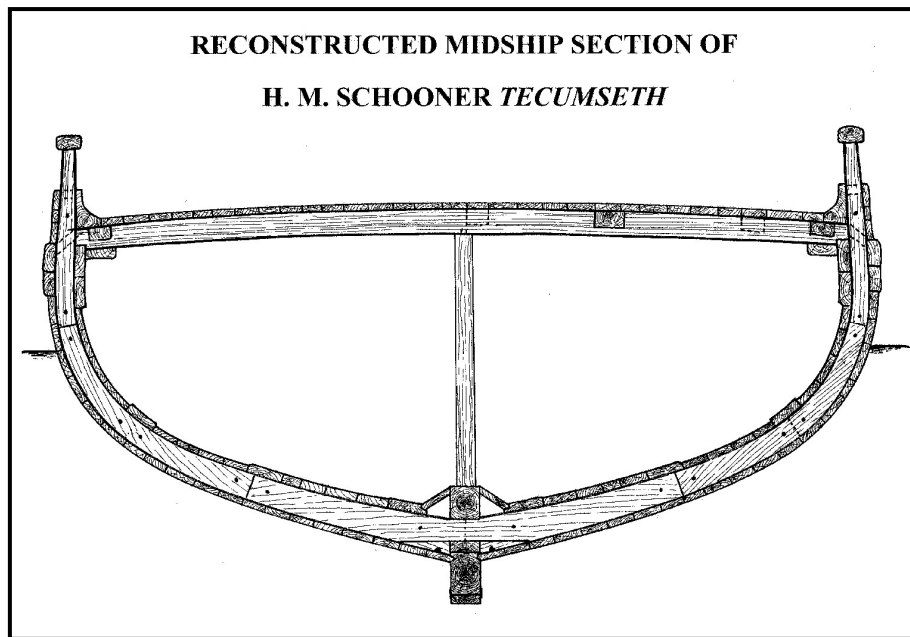

Figure 30: Reconstructed midship section of H.M. Schooner *Tecumseth*. Not to scale. (Detail from John R. Stevens, “The Story of H.M. Schooner *Tecumseth*,” 28. Drawing: Erich Heinold, Private Collection of Kevin J. Crisman.)

measurements are known, however. One of the three pieces measured approximately 8.00 inches (20.33 cm) long, and the other two were each 7.50 inches (19.05 cm). Two of the 1-inch (2.54 cm) diameter iron bolts appear to attach one end of the figure-of-eight pieces to the timber remains. It is also evident from the field notes that the plates were secured at an angle to the surviving timber. These pieces bear a striking resemblance to other iron pieces of *Tecumseth*'s chain and chainplate assemblies. The timber attached to the pieces, then, would be a plank or wale, which was once located along the vessel's side. On the outsides of each hull, enlarged strakes of planking, called wales, ran along the ship at or near the deck level. The wales offered longitudinal stiffening and support, and were used as a base of attachment for the standing rigging.

Chainplates

The vessels' standing rigging was attached to the outside of the hull through iron links called chains and chainplates. The lower deadeyes of the standing rigging had figure-of-eight-shaped iron straps. A similarly-shaped, but smaller, iron piece was attached to the outside of the hull, and another iron chain link appeared in between. Together, this system helped transfer and distribute the strain and load of the rig to the hull.

Several chains and chainplates were found when *Tecumseth* was salvaged (fig. 31). At their lowest ends, the links were attached to the hull with round-headed bolts. Near their 2-inch (5.08 cm) diameter heads, the bolts were octagonal in section.²⁸⁷ The majority of the body of the bolts was 0.88 inches (2.22 cm) in diameter, tapering to 0.63 inches (1.59 cm) at their terminal ends. The ends of the bolts inside the hull were slotted to receive retaining keys that kept them in place.

The lowest chainplate links were figure-of-eight shaped. Two examples measured 8.00 inches (20.33 cm) and 9.25 inches (23.50 cm) long. These links were made of square iron stock, 0.88 inches (2.22 cm) and 1.00 inch (2.54 cm) in section. A second, oval, link was attached to the lowest links. The oval link was made of round iron stock, 0.75 inches (1.91 cm) in diameter. The two surviving examples of these links measured 15.88 inches (40.33 cm) and 20.50 inches (52.08 cm) long. The last link in this chain, the lower deadeye strap, was another figure-of-eight-shaped iron piece made from round stock, which held the lower deadeye. The larger eyes of these links were 10.50 inches

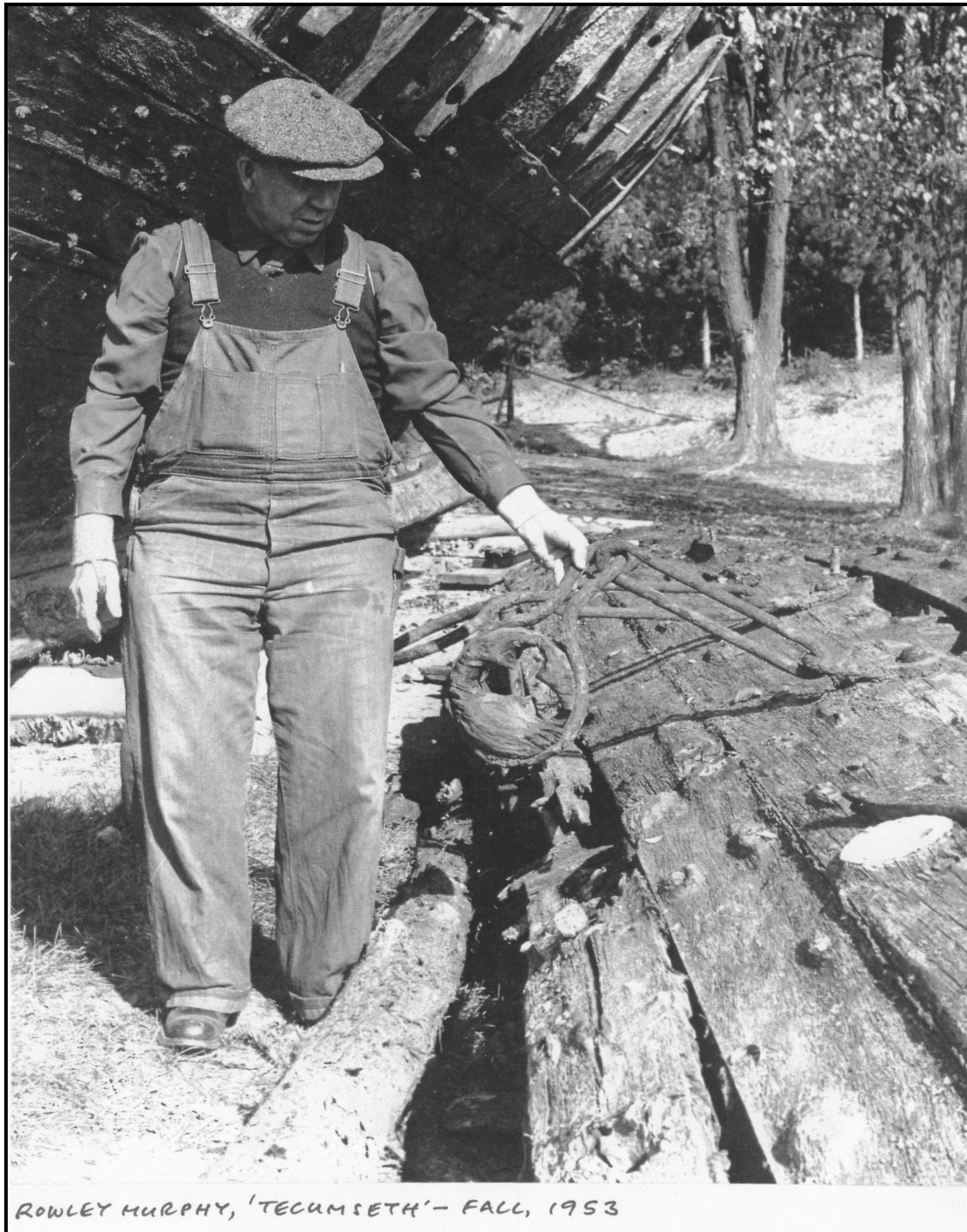

Figure 31. Historian Rowley Murphy holding chainplate on *Tecumseth* in 1953.
(Photograph: John R. Stevens.)

(26.68 cm) across, to accommodate an 8.00-inch (20.33 cm) deadeye. The smaller eyes were 6.00 inches (15.24 cm) and 6.50 inches (16.51 cm) long.

The iron straps that held the deadeyes and the lowest figure-of-eight shaped links appear to have been made to similar patterns. As each shroud was placed at a slightly different angle, the chains themselves had to be made to different lengths. This appears to have been accomplished by customizing the central oval link to the necessary size.

Planking the Ships

With the longitudinal and transverse timbers of the interior structure in place, the vessel could be planked. The ash²⁸⁸ garboard strakes on either side of the keel were 12 inches (30.49 cm) wide and 2 inches (5.08 cm) thick.²⁸⁹ These strakes may have warped and shrunk since the vessel was built; the construction draft indicated that the outer planking was originally 2.50 inches (6.35 cm) thick. While the garboard strake was made of ash, oak and pine were also used for planking.²⁹⁰ Other planks were laid beside the garboard and spiked to the interior frames with square-shanked spikes, 0.50 inches (1.27 cm) in section.

The exterior planking was made as watertight as possible by driving pieces of cotton and old rope, called oakum, in the gaps between the planks; the seams were then payed with pitch. After caulking, the hull was painted. As a cost saving measure, Royal Navy vessels were only to be caulked and painted once a year after the War of 1812.²⁹¹ Unlike

seagoing vessels, which were subjected to wood-devouring organisms that live in saltwater, the hulls of lake vessels did not need to be sheathed with copper.²⁹²

To allow water to run off of the decks, holes were cut into the exterior planking at deck level. These holes, called scuppers, were lined with lead to prevent rot from developing. The exterior planking was also used by sailors and those coming aboard. Short steps or cleats were nailed to the sides. When a portion of topside planking was raised in 1953, one such step and two lead-lined scuppers were evident.²⁹³

The interior planking, called ceiling planking, was laid over the inboard surfaces of the frames. Historian Rowley Murphy noted in 1954 that the ceiling planking was made of white pine.²⁹⁴ Besides contributing to the longitudinal stiffening of the hull, ceiling planking protected the cargo from the water that inevitably leaked into the hull. Because it played less of a role in keeping the vessel watertight, ceiling planking was not as thick as the exterior planking, and was not caulked. The ceiling planking was whitewashed to discourage rot.²⁹⁵

Several other artifacts were recovered during the 1953 salvage. These items reportedly included “part of a cat-head, a corner of a hatch-coaming, ring bolts, shank painter, main sheet traveller [sic] (probably)...round shot with broad arrow cast in them, a coin or medal, and Royal Naval uniform buttons.”²⁹⁶ In addition, a glass deck prism or skylight

was recorded during Heindol's investigations. Unfortunately, these artifacts could not be located or inspected during the most recent research seasons.

Newwash and Tecumseth and War of 1812-Era Ship Construction

Chronologically, *Newwash* and *Tecumseth* are not War of 1812 vessels. The war was over before their construction was ordered. Nevertheless, the conditions under which many War of 1812 ships were constructed were still prevalent when *Tecumseth* and *Newwash* were built. Arguably, the greatest restraint that the War of 1812 placed on ship construction came in terms of time. Ships were needed immediately, forcing shipwrights to cut corners and eliminate time-intensive methods in order to deliver a vessel quickly. Even though they were not traditional warships, *Newwash* and *Tecumseth* were wanted in short order. In spite of this, their actual construction time – from mid-May to mid-August 1815 – while quick, does not indicate a situation of particular duress.

The truncated construction time is manifested in the ways a shipwright utilized available timber. Some hull features are best made with naturally curved timber. Such timber was not always locally available and straight-grained timber was employed instead. Other features are made by the careful measuring, cutting and shaping of large pieces of wood. Seasoned timber, which was left to dry over time, is far superior to green timber, which was recently cut. Green timber was left to dry after being put in place on a vessel, potentially warping and twisting within the hull.

As previously mentioned, no knees were found in the hull remains of the two vessels. This fact draws immediate comparison with the hull remains of the U.S. Navy Brig *Eagle*, which was involved in the Battle of Plattsburgh Bay in September 1814. When he built *Eagle*, shipwright Adam Brown recognized the amount of time that could be lost in procuring proper timbers for knees. Brown chose instead to enlarge the clamp and waterway, which performed a similar ship-stiffening function, and eliminated knees from the hull entirely.

It should be remembered, however, that *Eagle* was a much larger vessel than *Newash* or *Tecumseth*, with a length of 117 feet 3 inches (35.75 m) between perpendiculars and an extreme breadth of 35 feet 5 inches (10.80 m).²⁹⁷ The longer hull was subjected to greater stresses that could distort her shape or destroy it entirely. In addition, *Eagle* had a much heavier deck load of 20 guns. The hulls of *Newash* and *Tecumseth* were obviously not under the same strains as the larger ship. As smaller vessels, *Tecumseth* and *Newash* may not have needed as much internal reinforcement.

The lack of knees within the hulls of *Newash* and *Tecumseth* may or may not be indicative of the hurried construction time typical of some other War of 1812 warships. After all, several lake warships of the period did have knees or some other form of internal support that served the same function. One such method involved the installation of long, straight-grained timbers that sat atop the ceiling planking within a hull and ran from the keelson to the clamp. These riders were placed at a diagonal angle,

which helped distribute deck loads to several frames. Diagonal riders were found in archaeological remains of the American War of 1812 brig *Jefferson* as well as in Royal Navy shipwright Robert Seppings' published writings on ship construction.²⁹⁸

Internal hull reinforcement was obviously of great concern to shipwrights. Those who were tasked with building ships for only short-term purposes could afford to take some shortcuts in construction. While it is not necessarily surprising that small, War of 1812-era lake vessels like *Newash* and *Tecumseth* had no knees, it is surprising that little regard for any other form of internal reinforcement was paid. No dimensions were taken of the "wide shelf [clamp]" observed after the salvage, making it difficult to determine if the hulls were reinforced with strong timbers in place of knees. John R. Stevens recorded that "[t]he closest approximation to knees were heavy chocks placed under the shelf at the ends of the...beams."²⁹⁹ Unfortunately, Stevens did not record the dimensions of these chocks. His drawing of the midship section of the vessel seems to indicate that the clamp and heavy chocks were about the same size as the thickest strakes of ceiling planking.

The lack of internal reinforcement could be indicative of a hurried construction time, which may also be evident from some other features. *Tecumseth's* gripe was made from a large piece of straight-grained timber, and simply cut to the desired shape. The stemson was made from unseasoned wood, which has since warped and distorted. *Tecumseth's* outer hull planking was fastened to the frames and end posts with a

combination of iron fasteners and treenails. Treenails are dowel-like rods of wood inserted into a drilled hole. Often the ends were pegged or wedged to expand the wood and ensure a tight fit. Treenails were driven through planking and frames, making a secure joint. They were time-consuming to make and install, however. In a situation where speed is vital and iron is available, iron fasteners may be employed to economize the building time; for this reason, treenails were rarely used in wartime lake vessels.

When speed of delivery is critical, however, many other hull features may show signs of hurried fabrication. Adam Brown increased the speed in which he could deliver *Eagle* by only very roughly shaping many of the timbers. The keelson, for example, was not notched to fit over the brig's frames but was attached with iron drift bolts.³⁰⁰ The brig was also built with very simple stem and stern assembly; the latter had no stern knee but only a stack of horizontal timbers.

Tecumseth and *Newash* do not fit a particular pattern laid out by earlier warships. The schooners had plain bow arrangements, made from a simple, functional design. This utilitarian bow was typical of war-time vessels, unlike the elaborate bow seen on the schooners *Hamilton* and *Scourge*, which sailed as merchant craft on Lake Ontario before the war. The keelson on *Tecumseth* was notched to fit over each floor, a time-consuming but ultimately advantageous method. Whereas warships built to withstand heavy fighting were constructed from heavy, stout timbers, *Tecumseth* and *Newash* were built with frames of modest dimensions on relatively widely-spaced centers. One feature

that seems to be common among most War of 1812-era ships is the use of green timber. Even a few years earlier, the employment of green timber in construction may have seemed foolish. The limitations of existing reserves of timber for shipbuilding were met and exceeded during the war, and those vessels built immediately afterwards suffered from the same lack of resources. Simple, quick construction seems to have influenced, but not constrained Robert Moore's design and creation of the two schooners.

Newash and *Tecumseth* had very shallow drafts, even for lake vessels. There was a drastic difference between the depths of seagoing ships and lake vessels of the time. With an abundance of freshwater and nearby shores, the hulls of lake vessels did not need to be as large as seagoing ships. As was the case with internal hull reinforcement, certain features were necessary on larger vessels but not on smaller ones. A smaller vessel could, of course, be shallower, and smaller vessels often were. It should be noted, though, that while *Newash* and *Tecumseth* were considerably smaller than other contemporary British vessels on the lakes, they were the largest Royal Navy vessels on Lakes Erie and Huron at the time. Enlarging the hulls by a few inches would have given the ships greater carrying capacity. Even a few more inches of keel would have given them more lateral resistance, and potentially better sailing characteristics.³⁰¹ The groundings of the two vessels on the bar at the mouth of Grand River should not indicate that the hulls were too deep as they were designed but rather that the British establishment was built at a poorly-chosen location.

By the time of their construction, both British and American shipwrights had been building vessels in wilderness shipyards, under conditions of duress, for a few years. The Owen brothers and their predecessors must have had some knowledge of the constraints that local timber and quick construction placed on ship longevity. They must have been aware that larger vessels, like the three frigates planned for Lake Erie, would have been more vulnerable to the strains of heavy deck loads and long sailing careers than smaller vessels constructed of the same timbers. *Newash* and *Tecumseth* may be seen, then, as a compromise between the limits of local timber, time and maximum capacity. The forests of the Great Lakes produced far more straight-grained timber than compass timber. Perhaps E.W.C.R. Owen's specification that the schooners be built to 130 tons was made with these resources in mind. Robert Moore then, having more first-hand knowledge of the needs of the vessels, may have increased the vessels slightly – to 166 tons – on the thought that he could eke a bit more strength out of the available resources.

CHAPTER XI

HULL ANALYSIS

A study of the hull³⁰² was undertaken, based on the lines drawing made by Robert Moore in April 1815 (see fig. 2). The draft shows three views of the ship: the body plan, which shows several sections of the ship as if viewed longitudinally; the sheer plan, which shows the ship as viewed from the side; and the half-breadth plan, which shows half of the ship as viewed from above.

Based on the features shown in the drawing, it may be assumed that Moore's draft was made in preparation for construction. Moore's drawing shows only sections, a single waterline, and diagonals. Sections are shown in the body plan, which represent the external faces of selected frames spaced every five feet (1.52 m); waterlines and diagonals appear as curves in the half-breadth plan (diagonals are dashed lines). Aft of midships, sections appear only for sections 4, 8, 12 and 14, at intervals of ten feet (3.05 m) though the profile and half-breadth plans show a section every five feet (1.52 m). Details of the bow and stern are shown, illustrating the specific timbers needed to assemble the stem, apron, keelson, deadwood and sternposts. These details would be critical in constructing the spine of the ship. Section lines are necessary in creating the frames that form the body of the hull and diagonals are useful in assuring that the finished skeleton can be planked without problem. Other lines, which give a better idea of the full hull form, may have been employed in the design phase, but omitted from the construction drawing.

Design Lines

A more detailed draft than Moore's extant plan may have been made to initially design the hull. Together, section lines, waterlines, buttock lines and diagonals are indicators of a hull's particular design. As previously mentioned, though, some of these lines would have been extraneous and unnecessary for construction, and so they may have been eliminated from the draft. To get a better idea of what the entire submerged hull of *Tecumseth* and *Newash* would look like, the additional lines were redrawn, including two additional waterlines and two buttock lines (fig. 32).

Waterlines, buttock lines and diagonals may give an indication of how a shipwright imagined a hull moving through the water. The submerged portion gives a hull her particular characteristics. The flow of water around a hull was of great consideration to naval architects in the 18th and 19th centuries. The sections and waterlines were significant to those who believed that the flow of water was around a submerged hull. Another school of thought posited that the bulk of water flowed under a hull, making buttock lines of primary importance. Still another theory was that water flowed around a hull following diagonals.³⁰³

In fact, the idea of a unidirectional flow is an oversimplification. As illustrated by noted naval historian Howard I. Chapelle:

The flow is in currents and eddies, of varying magnitudes and velocities, with ill-defined boundaries...Generally, the water near the keel and out to the bilge, in

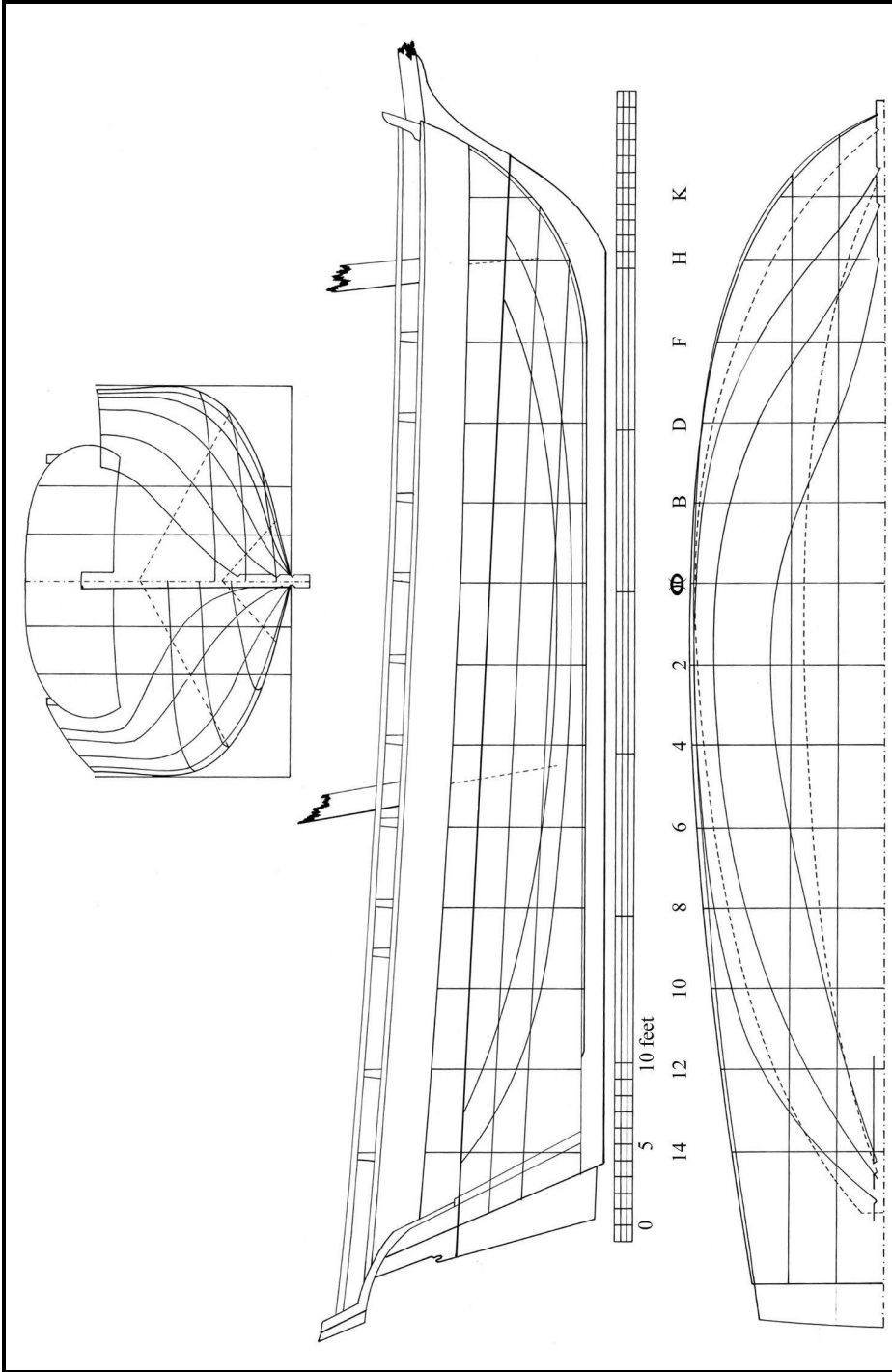

Figure 32: Revised lines drawing, showing two additional waterlines and two additional buttock lines.

the forebody, appears to move under the hull, while that at the bilges follows a fairly normal diagonal, and that above the bilge moves around the sides of the hull.³⁰⁴

However water was believed to flow around the hull, it presented resistance to motion. Resistance occurs in two ways: “frictional resistance due to the sliding of particles of water over the immersed surface,” and “wave resistance due to the formation of waves by the boat.”³⁰⁵ Reduction of this resistance was of primary importance in designing a swift hull. It is not expressly clear that Robert Moore set out to design a particularly fast ship. In the nature of their duties, though, it would be advantageous to have swift sailing characteristics, and it is known that *Tecumseth* and *Newash* were intended to be “sharp” vessels.

Designing a sharp vessel involves minimizing any unnecessary bulk in the hull and reducing resistance. Earlier vessels, built to maximize cargo capacity, had nearly vertical stems and sternposts and flat-bottomed sections. Sharp vessels, in contrast, had angular, V-shaped sections and angled, or raked, stems and sternposts. Raking the stem forward and the sternpost aft gave the vessel a longer overall length without a longer keel.

Raked stems and sternposts allowed both *Newash* and *Tecumseth* a length over the deck of 70 feet 6 inches (21.49 m). This number is slightly misleading, though, because the

portion of the hull actually in contact with the water was much less. Obviously, lower portions of the hull are shorter in length. As the amount of hull immersed could vary at any time due to loading considerations and dynamic conditions of heeling, it is very difficult to analyze a hull except in theory. For the purposes of this discussion, the predicted load waterline that appears on Robert Moore's draft was used as the upper extreme of the submerged hull. *Tecumseth* and *Newash* had a length along the load waterline, as predicted by Moore's draft, of 66 feet 6 inches (20.27 m).

In his study of fast sailing hulls, *The Search for Speed Under Sail: 1750 - 1855*, Howard I. Chappelle noted three main areas where speed advantages could be had. "[A] sharp entrance was advantageous for speed as was length of hull, and also that hollow in the vicinity of the forefoot...could be expected to produce a fast sailing vessel."³⁰⁶ While true understanding of hydrodynamics would not come until much later, empirical observations and experimentation led to some early conclusions about fast hull forms. Many of the characteristics had been discovered as early as 1670, and documented in the Pepysian Library.³⁰⁷

The entrance of a vessel, or the forward surface she presents to water, is of primary importance in speed. As a ship moves forward, she first encounters still water in front of her as resistance. That water must be pushed aside for the vessel to move. A plane placed perpendicularly to a surface of water will present the most resistance to forward motion. As that plane is angled away from the perpendicular, resistance is reduced.

Essentially, this is the same as sticking a hand out a moving car's window. The most pressure is felt when the hand is perpendicular to the road, with less and less pressure as the hand is angled in either direction. Resistance decreases in approximate proportion to the sine of a plane's angle to the water. A plane perpendicular to a water surface will present a resistance factor of 1. A plane at 80° to the same water surface has a resistance factor of .98. A plane at 70° presents a factor of .94, and so on.³⁰⁸ *Newash* and *Tecumseth's* stems had an angle of 62° to their load waterlines (fig. 33). Though the resistance factor at that angle, .88, is only a theoretical expression, it is apparent that reducing the hull's resistance at the entrance was a concern of the designer. The entrance of the submerged body is also significant, just like the entrance of the stem. The angles of the two additional buttock lines were 34° and 28° , indicating the sharpness of the hull form.

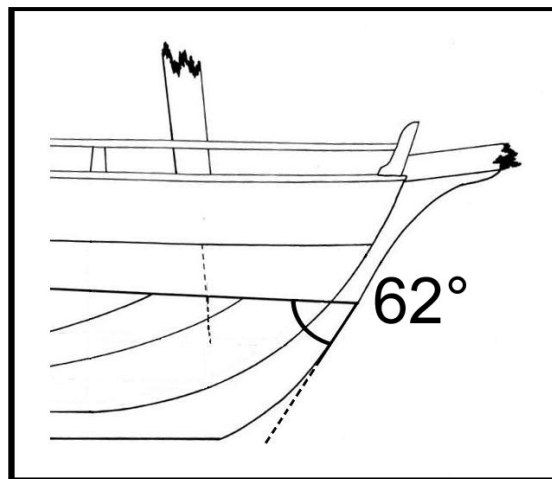

Figure 33: Angle of entrance in bow.

After the sharp entrance, the hull gradually widens. This wider portion of the hull actually encounters less resistance than the entrance. The stem is always encountering water that is not moving, while the after parts of the ship encounter water that is already in motion in the same direction as the ship, making it less resistant than still water.³⁰⁹ Logically, then, the widest point in a ship should occur in the middle of her length, so that the hull forms a nice oval shape for water to flow around. Naval architects in the 16th century noticed, however, that fish are not found with that nice, ovular shape; a painting by Matthew Baker shows a fish form superimposed on the submerged portion of a ship's hull. The widest part of a fish is found further towards its head than the middle of its body length. When this characteristic was adopted in ship design, it was called a "codfish head." A codfish head-type hull has the widest point, or midships section, well forward of the midpoint of the waterline length. On *Tecumseth* and *Newash*, the midships section is located 6 feet 7 inches (2.01 m) forward of the midpoint of the load waterline (fig. 34).

One worry of a codfish head-style hull is the potential for wave-making, the second part of resistance. As a vessel travels through the water, she creates her own waves. It is easy to imagine the wake of a modern power vessel, but even sailing ships create waves as they travel. These waves present additional resistance from the water. Form and proportion almost exclusively govern a hull's wave-making resistance.³¹⁰ A codfish head bow can present problems in wave-making resistance. With the midships section forward in the ship, it has the potential to create waves early in the ship's movement,

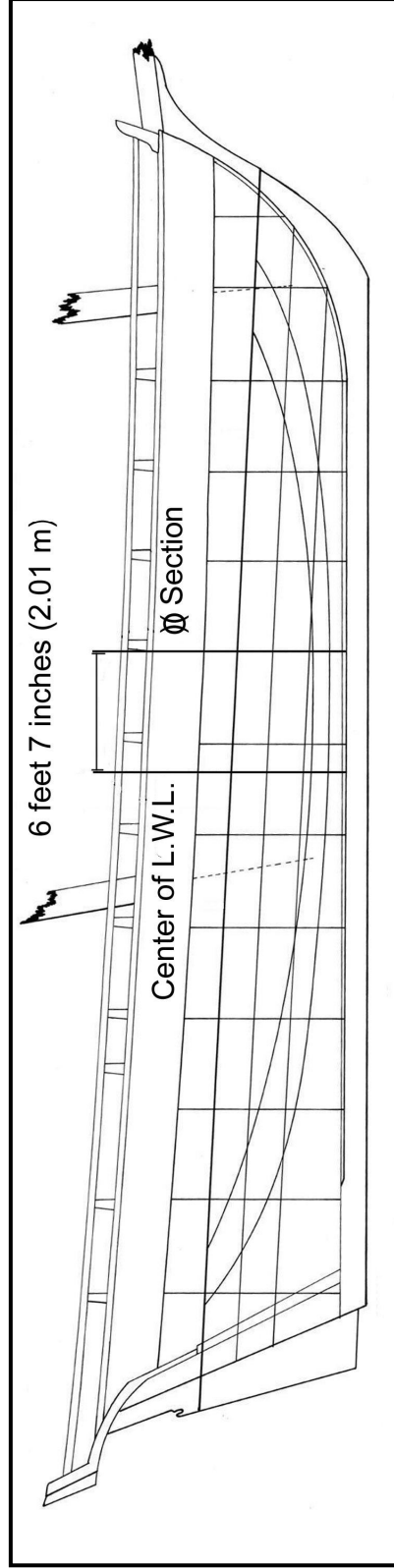

Figure 34: Distance between midships section and center of load waterline.

reducing her speed. One way to reduce this potential is to have a “raking midsection;”³¹¹ the widest point of the vessel is moved further aft in the lower portions of the ship.

Tecumseth and *Newash* have only a slight rake to their midsections. The widest point in the load waterline is at the midships section, but in the lower two waterlines, it does appear very slightly further aft.

Length of a vessel, along the load waterline, is also significant to speed. Physically, a hull is limited in terms of achievable speed by wave-making resistance. This limitation, called hull speed, comes when a vessel is restricted by the waves she makes. A vessel traveling through the water creates a bow wave and a stern wave. At the upper limits of her potential speeds, the bow and stern of the ship are at the same point in the bow and stern waves, and a long trough forms between them. At this point, the hull is essentially trapped in a hole. Sailing at speeds higher than hull-speed is difficult, but not impossible. The longer a hull is, however, the longer the time before hull-speed is achieved. Simply put, the longer a ship is, the faster she can go.

In addition to the codfish head, the draft of *Newash* and *Tecumseth* shows a hollow, or concavity, in the load waterline seen in the half-breadth plan. Such a hollow has a tendency to create a “shoulder” abaft the hollow, which produced greater wave-making resistance. Variables such as vessel speed or hardness of shoulder affected the impact of these shoulders in wave-making resistance. To lessen their impact, shoulders were raked. This meant shaping the hull so that “the shoulders in each level line (or

waterline), from load line down, were shifted aft in the forebody and forward in the afterbody.”³¹²

With the two additional waterlines, it can be seen that the hollow indeed shifts aft further down the hull. The rake in the hollow is far more pronounced than the rake in the midsection. It is interesting to note that there does not appear to be any hollow near the sternpost, as might be expected. Chapelle’s study had noted that hollow in the after portions of the ship could also be expected to give a ship swift sailing qualities. In the case of *Tecumseth* and *Newash*, such hollow might have been a little too extreme, given the ships’ shallow drafts.

The draft of a ship is usually significant in determining her characteristics, particularly in the cases of *Newash* and *Tecumseth* . Interestingly, depth is not as great a concern in hull design as one might think. “Resistance is nearly constant for all depths at any named speed. In other words, depth of immersion does not seem to change resistance.”³¹³ This allowed ocean-going ships, which did not face the draft constraints that ships in shallower waters did, to balance a lofty rig with a deep hull. In shallow waters, however, deep hulls were impractical. Arguably the most striking feature of *Newash* and *Tecumseth* were their remarkably shallow hulls. In the draft, the ships were predicted to draw 6 feet (1.83 m) forward and 9 feet (2.74 m) aft.

When the keel is removed as a factor in examining the hull, the ships draw even less. The mean draft, averaged from the depths in the bow and stern, is only 6.25 feet, or 6 feet 3 inches (1.91 m). The shallowness of the hulls must be kept in mind when examining the next calculations. It is one thing to have a sharp-hulled vessel, but another thing to have a sharp hull that is exceptionally shallow.

It may seem difficult to compare vessels of different sizes, or even the same sizes. Two vessels built with the same overall length may appear very different below the water line. To compare ships, it is helpful to look at a number of different ratios.

Coefficients and Ratios

Most hull coefficients and ratios involve the same basic hull dimensions, which are given in Table 2. Many of the calculations do not take the keel, stem and sternpost into account, as they are measures of the hull alone.

Table 2: Hull Dimensions

Length over deck	70 feet 6 inches (21.49 m)
Maximum Beam	24 feet 5 inches (7.44 m)
Load Waterline, extreme	66 feet 6 inches (20.27 m)
Load Waterline without posts	63 feet 11 inches (19.49 m)
Load Beam, moulded	23 feet 4 inches (7.11 m)
Load Beam, extreme	23 feet 10 inches (7.27 m)
Mean Draft	6 feet 3 inches (1.91 m)
Volume of Hull, excluding keel and posts	3989.10 cubic feet (113.05 m ³)
Volume of Hull, inclusive of posts	4068.97 cubic feet (115.31 m ³)
Volume of Hull, long tons in salt water ³¹⁴	116.26 long tons
Volume of Hull, long tons in fresh water	119.05 long tons
Waterplane Area	1118.67 square feet (103.97 m ²)

Two ratios that are easily calculated are the length-to-beam ratios. Length-to-beam ratios can be calculated from overall maximum dimensions, or from load waterline dimensions. Using the overall dimensions of length over the deck and maximum beam, a ratio of 2.88:1 is found. Using dimensions of load waterline length and beam yields a ratio of 2.70:1. These ratios show that the vessels were more than twice, but not quite three times, as long as they were wide. Typically, ratios between 2.5:1 and 3:1 are indicative of good sailing ships. Later ships would have even higher length-to-beam ratios, but the ratio is not necessarily indicative of any quality on its own.

Like the length-to-beam ratio, there are several hull coefficients that can be calculated, but which are fairly arbitrary on their own. The coefficients are useful in comparing dissimilar and similar ships. In his work *The Search for Speed Under Sail: 1750 – 1855*, Chappelle calculated hull coefficients for 100 vessels from the period mentioned. For comparison purposes, coefficients for the vessels from 20 years previous to *Newash* and *Tecumseth*'s construction to 20 years later are provided in Appendix D.

A block coefficient is a ratio of the volume of a ship's submerged hull (exclusive of keel, stem and sternpost) to the volume of a block of the same overall dimensions (load waterline x load beam x mean draft). For *Tecumseth* and *Newash*, this is the ratio of 3989.10 cubic feet (113.05 m³) to 9905.73 cubic feet (280.73 m³), or .40.

A midship coefficient is a ratio of the area of the midship section to a plane of the same overall dimensions. The area of the midship section for the two hulls is 95.22 square feet (8.85 m²). The area of a plane of the same overall dimensions (load beam x depth at midship section) is 141.02 square feet (13.11 m²), yielding a ratio of .68.

The area of the midship section also factors into the prismatic coefficient. This is a ratio of the volume of the submerged hull to a prism having the same area as the midship section and the length of the load waterline. The ratio of 3989.10 cubic feet (113.05 m³) to 6086.18 cubic feet (172.47 m³) is .66.

Another ratio that can be useful in comparing hulls is the camber-length ratio. The information for this ratio is derived from a quarter-beam buttock line. As previously discussed, the buttocks are lines which describe the shape of the hull as if sliced longitudinally and viewed from the side. For this ratio, a buttock line is drawn at “one quarter of the load waterline beam (out from the longitudinal and vertical centerlines of the hull)”³¹⁵ (see fig. 32). Using only the portion of that line which is below the load waterline, the length and maximum depth, or camber, are measured. The ratio of the camber to the length provides further insight into two hulls having the same prismatic coefficient. “If two vessels have the same or nearly the same prismatic, the one with the larger quarterbeam buttock camber-length ratio can usually be presumed to be the faster.”³¹⁶ A buttock line placed 5 feet 10 inches (1.78 m) from the centerline is 52 feet

10 inches (16.11 m) long with a 4 feet 6 inch (1.37 m) camber. This yields a buttock camber-length ratio of 11.74.

Buttock lines can also be used to examine how the forward part of the hull would have encountered the water. After all, a sharp stem is wasted if the rest of the hull is not built upon similar principles. The angle formed by the intersection of a buttock line placed 2 feet 11 inches (0.89 m) from the centerline is 34°. The angle at the quarterbeam buttock is 28°.

Chapelle calculates a displacement-length ratio for his list of hulls as well. This ratio is calculated by the following formula.

$$DL = \frac{\text{Displacement}}{(0.010 \times \text{Length})^3}$$

Since this number is most useful in a comparison with the coefficients from Chapelle's work and those vessels were ocean-going hulls, the saltwater displacement for *Tecumseth* and *Newash* was used. A saltwater displacement of 116.26 long tons and a length of 63 feet 11 inches (19.49 m) yields a displacement-length ratio of 445.23.

A final ratio used to compare vessels, particularly those with noted speed qualities, is a speed-length ratio. Swift vessels can be built to any size or length, but those with longer load waterlines are faster, at least theoretically.³¹⁷ Nevertheless, a smaller vessel might achieve great speed for her length, placing her on par with a much larger vessel even

though the larger vessel may have a higher overall speed. To compare these two vessels, a speed-length ratio is used. Calculating this is simply a factor of dividing a known speed of the vessel by the square root of her load waterline length to arrive at a factor. Chapelle gave the following illustration of this concept:

For example, an extreme case may be used to show the use of this quotient: a vessel 121 feet [36.89 m] on the load waterline has recorded a run of 16 knots, while another vessel 240 feet [73.17 m] on the load waterline ran 21 knots. Which of the two vessels had the faster design on the basis of speed-length? Calculating the speed-length ratio of each it is found that the 121-foot [36.89 m] vessel has a ratio of 1.455 while the ratio of the 240-foot [73.17 m] vessel is 1.355. This indicates that the 121-foot [36.89 m] vessel is of the basically faster design.³¹⁸

None of the surviving logbooks of *Newash* or *Tecumseth* record any known speeds. Speed-length ratios may still be calculated, however, on the basis of known examples from fast ships. Chapelle noted that speed-length ratios of 1.25 – 1.35 were not uncommon in seagoing sailing ships. With a load waterline of 66 feet 6 inches (20.27 m), a speed of 10.19 knots would have to be achieved to reach a speed-length ratio of 1.25. For a ratio of 1.35, 11.01 knots would have to be reached.

It is important to note, as Chapelle did, that the observed maximum speed “is the highest speed recorded in one hour of sailing on any point.”³¹⁹ Over the course of a passage,

particularly one of long duration, the average speed fell significantly, and a speed-length ratio calculated for an average speed would be much less than those just discussed.

Unfortunately, there are no decisive boundaries in terms of these ratios. There is no definition of a sharp vessel, even in terms of these various coefficients. These terms are used only for comparison of different hulls. Of course, it must also be considered that all calculations here were done from a construction drawing, which may or may not have truly reflected the completed vessels.

Waterplane Area and Immersion

A waterplane coefficient can be calculated by comparing the known waterplane area with a plane having the dimensions of the extreme load beam and the load waterline length. The waterplane area was calculated at 1118.67 square feet (103.97 m²), while the larger plane had an area of 1584.89 square feet (147.29 m²), giving a coefficient of .71.

The waterplane area is also used in another calculation which has a little more practical, albeit theoretical, value. The waterplane area, when divided by a factor of 420, gives the number of tons necessary for one inch of hull immersion.³²⁰ This number, called TPI (for Tons Per Inch), is 2.66 long tons for *Tecumseth* and *Newash*. This means that, at this particular draft, 5958.4 pounds (2708.36 kg) loaded onto the vessels would cause their drafts to increase by one inch.

To put this number into perspective, let us look at the example of lightening the hulls to cross the Grand River bar at the end of the winter of 1815 – 1816. Second Master Childs' logbook records a draft of 7 feet 2 inches aft (2.18 m). The prescribed draft from Moore's draft was 9 feet (2.74 m) aft. In order to achieve this difference of 22 inches (55.89 cm), it may be estimated that at least 50 tons³²¹ (112,000 pounds or 50909.10 kg) had to be removed from the hull.

The TPI can also be used to look at the effect of the guns on deck. Using the average weight of two 24-pounder carronades and two 24-pounder long guns, it was determined that the guns alone added 14,560 pounds (6618.18 kg) to the hull. The guns alone were responsible for approximately 2 inches (5.08 cm)³²² of the vessels' drafts.

Deck-Edge Immersion and Downflooding

One final calculation that can be found from analyzing the construction draft is the angle of deck-edge immersion. This angle may be of little use in examining a hull on paper, but it was of incredible importance to those sailing in the ship. The angle of deck-edge immersion is the limit of how far a ship can be heeled without running the risk of downflooding.

Forces of both gravity and buoyancy are always at work in a hull afloat:

Water exerts an upward pressure on the underwater surfaces of the vessel that tends to push it up and out of the water. The upward forces of buoyancy are

opposed by the downward forces of gravity which tend to make the vessel sink. The buoyant forces, which act vertically upward, are exactly equal to the weight of the water which the vessel displaces.³²³

A static equilibrium between these forces keeps a vessel upright when still, and the tendency towards equilibrium returns a vessel to her upright position when temporarily heeled. Every hull tends toward a static position, and the tendency to do so is called a righting arm. The righting arm is greatest when the vessel is heeled to approximately the same angle as the deck-edge.³²⁴ Beyond the angle of deck-edge immersion, the righting arm still exists, so a vessel can return to an upright state after heeling beyond deck-edge immersion. At greater angles, the righting arm decreases, and the stability of a ship may be compromised further by downflooding or loose water on the deck. The angle of deck-edge immersion may be considered the limit of comfortable sailing, but not a point of no return.

In a vessel such as *Newash* and *Tecumseth*, with their low open rails, deck-edge immersion is exceptionally low. The angle of deck-edge immersion from Robert Moore's draft was taken as the angle between the midships load waterline and the height of the deck at the midships section. (fig. 35). It is a frightening 18°.³²⁵ There is a slight difference between the height of the deck and the maximum height of the outer planking at the same section. The planking extends 1 foot 2 inches (0.36 m) higher than the deck. This gives a slight buffer, allowing the ship to heel to 21° before water actually began

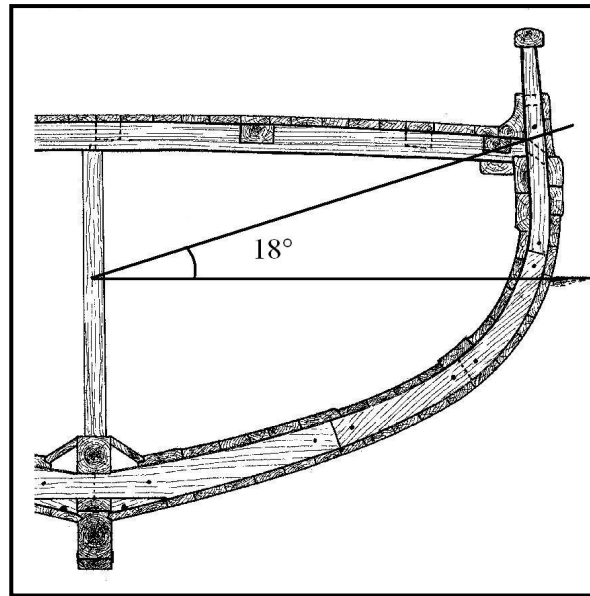

Figure 35: Angle of deck-edge immersion.
 (Detail from John R. Stevens, “The Story of
 H.M. Armed Schooner *Tecumseth*, 28.)

washing onto the deck. In comparison, Chapelle noted a range of heeling angles for many War of 1812-era ships of 45° to 50° , with other ships reaching ranges of 55° to 60° .³²⁶

Tender and Stiff Vessels

The state of equilibrium between forces of buoyancy and gravity, as mentioned, keeps a vessel upright. The stability of a ship is concerned with the vessel’s ability to right herself after a roll. How a vessel is loaded affects the way a vessel rolls and rights herself, and how long she may take.

If a vessel is laden in such a manner as to be top-heavy, she will be considered “tender.” This means that the vessel has a weak ability to right herself, and will have a long, sluggish roll. If an opposing measure is taken, and a vessel is loaded with too much weight concentrated low in the hull, she will become “stiff.” A stiff vessel has a strong tendency to return to an upright position, but may do so with quick, harsh motions that can damage the vessel.

Both tender and stiff conditions can become problematic. A stiff vessel may be uncomfortable for those onboard, “and can also lead to synchronous rolling where the period of the ocean waves and the apparent rolling period of the vessel are exactly the same – resulting in very heavy rolling or, if sustained, capsizing.”³²⁷ A tender vessel has poor stability and a smaller margin of safety if flooding occurs or her cargo or ballast shifts. Tenderness can also cause a vessel to “capsize without warning as a result of a series of unexpectedly high waves, heavy weather or relatively slight damage...There will also be a greater tendency for seas to break over her weather decks.”³²⁸

Discussion: Hull Design and Purpose

In the end, hull analysis is difficult. It should be remembered that all of these coefficients and ratios and numbers have been calculated from a paper drawing. The draft may not truly represent the ships as they were launched. Furthermore, after the numbers are calculated, they must be examined.

Think of the hundreds of models of cars on the road today. There are miniscule sub-compact cars, monstrous trucks and everything in between. Ships are no different. Even today, there are dinghies, daysailers, cruise ships and freighters. Finding any sort of pattern among the multitudes of vehicles is difficult, even painful. Perhaps the pattern is not in the cars but in the people who drive them. After all, the owner of the sub-compact expects a certain level of performance and selected that vehicle for specific reasons, just as the owner of the enormous truck chose it.

Hulls, too, were built for specific functions. *Newash* and *Tecumseth* were built to transport goods. They also had to carry guns and a large crew who were to be instantly ready for action. They were built as sharp vessels, with fine entrances, hollows in the bow and three feet (0.91 m) drag to their keels. These were probably incorporated into the design to make the ships swift. The distant parts of the Canadian frontier needed vessels that could move supplies and men quickly. Yet, the coefficients do not reveal that the hulls were built to any extremes. They were by no means the sharpest vessels of their day, nor is there evidence that they were lauded for exceptional speed.

It should be noted and stressed, however, that these hulls were extremely shallow, a condition which is not adequately reflected in the hull coefficients. Work on the lakes necessitated a shallow draft, and the Great Lakes offered more protection than would be seen in the middle of the ocean. Still, the lakes were not subjected to continuous calm

conditions, and there must have been times when *Tecumseth* and *Newash* became truly frightening ships.

In addition to the shallowness of the hulls, stability was a concern, and the dynamic nature of their work did little to alleviate this. Each time that *Newash* and *Tecumseth* were loaded, a new stability condition was created within their hulls. As transport vessels, the officers and crew would have had opportunities to observe their vessels in various states and conditions, thus gathering a feeling for how proper loading could be accomplished. The fact that their cargoes regularly included men, women and children, who could not be counted on to remain in one place, must have been a particular difficulty in ensuring the safety of the ship and those aboard.

It is almost a shame that the careers of these vessels were so affected by the political atmosphere of the time. It would be very interesting, to say the least, to see how these ships might have been regarded by their officers and crew had the vessels had longer lives.

Penetanguishene's Sailing Replica

Sailing replicas and reconstructions can often be useful in experimental archaeology, offering a different perspective of a sailing vessel than what can be gathered from historical documents and hull remains. Replicas and reconstructions can also be beneficial in raising awareness of an area's maritime past by providing an active,

tangible exhibit for the public to experience. In order to carry members of the public, however, modern vessels must comply with a rigid set of safety standards. Often, these standards involve compromising some of the historical integrity of a vessel, in order to fulfill a certain mission.

In 1991, a sailing replica of H.M. Schooner *Tecumseth* was built for Discovery Harbour (Havre de la Découverte). To meet with modern safety standards, some concessions were made in the design and construction of the schooner. The most notable of these was the choice of hull material; H.M.S. *Tecumseth*, as she is known, is a steel-hulled vessel. Undoubtedly, steel was chosen as the building material because of the increased longevity and ease of maintenance, as compared to a wooden hull. Wooden vessels require continual inspection and upkeep, which can become very costly.

The choice of steel as a hull material has limited the number of comparisons that can be drawn between the replica vessel and the original hull design and remains. Steel construction methods are completely different than wooden shipbuilding, and steel vessels display a distinct set of characteristics on the water. In the summers of 2007 and 2008, H.M.S. *Tecumseth* was on display at the museum's waterfront, though in previous years she had sailed to other Great Lakes ports. Because recent sailing schedules had not allowed many of the museum staff to gain first-hand experience on the schooner, it was difficult to gather anecdotal information on the vessel's sailing characteristics. To avoid any confusion and focus the current discussion to the information that can be

gathered from the documentary and archaeological remains of *Tecumseth* and *Newash*, this discussion will not include references to the sailing replica.

CHAPTER XII

RECONSTRUCTING THE SCHOONER RIG

A number of historical documents are stored in the Bayfield Room at the Penetanguishene Public Library in Penetanguishene, Ontario, and are accessible for viewing upon request. These documents focus on Penetanguishene's naval and military history, as well as the town's early development. A number of documents from the War of 1812 and early 19th century can be found as well, having been copied from archival materials now held at the Library and Archives of Canada. One particular item, a rigging warrant written by Lieutenant Thomas Bushby in 1815, contained a wealth of information on *Newash*'s sailing rig. A majority of the documents were compiled and consulted during the research that allowed the reconstruction of the Penetanguishene Navy Yard, now open to the public as Discovery Harbour (Havre de la Découverte). Some material dealt specifically with research conducted in preparation for the construction of Discovery Harbour's replica sailing vessel, H.M.S. *Tecumseth*. Previous to the construction of this vessel, John R. Stevens published a rigging plan based on research and hull elements observed in 1954 (fig. 36). Stevens portrayed *Tecumseth* in her early sailing configuration, with square main and fore topsails, while the modern replica sails with a gaff topsail on the mainmast.

In favor of a fresh approach, these previous rigging interpretations were disregarded in the preparation of the current reconstruction (fig. 37). The major sources for this reconstruction were the masting and rigging treatises of David R. Steel, originally

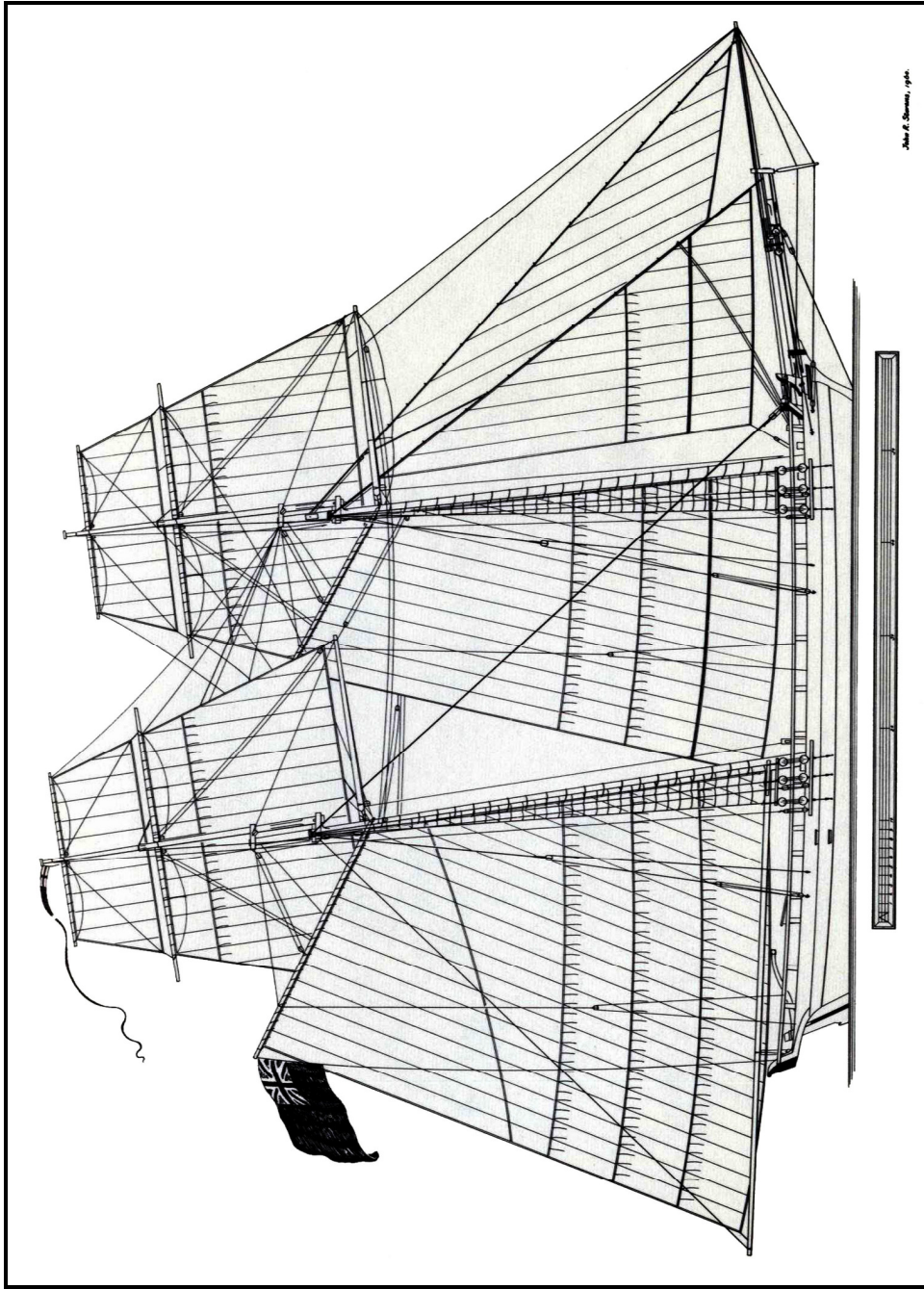

Figure 36: John R. Stevens' reconstructed rigging plan. (Detail from John R. Stevens, "The Story of H.M. Armed Schooner *Tecumseth*," 29.)

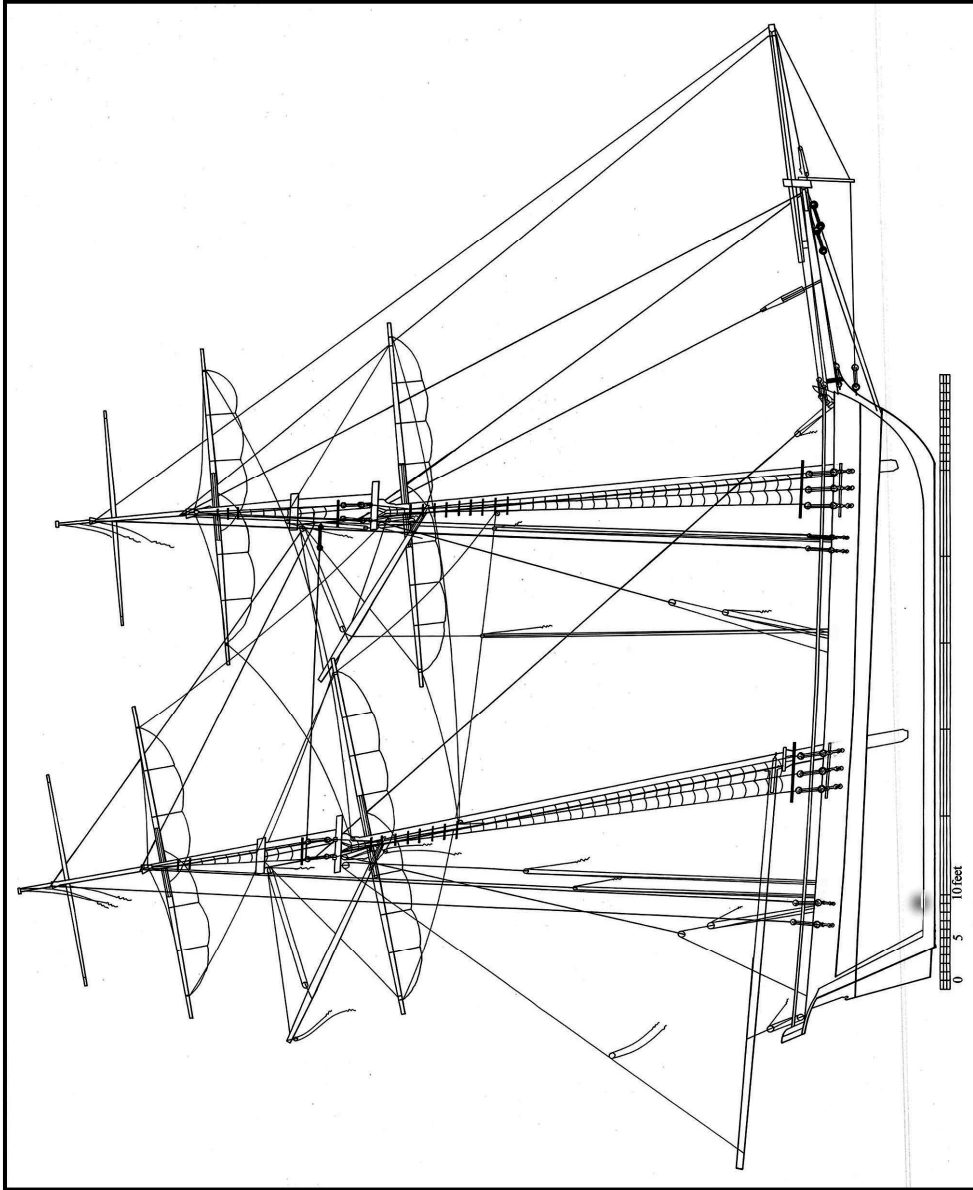

Figure 37: Reconstructed schooner rigging plan.

published in 1794³²⁹ and John Fincham, originally published in 1829.³³⁰ Specifications for many elements were taken from Darcy Lever's *The Young Sea Officer's Sheet Anchor*, originally published in 1819. The reconstruction was also heavily informed by Thomas Bushby's rigging warrant,³³¹ taken aboard *Newash* in September 1815. It should be noted that this warrant lists the sails onboard in the schooner's first configuration, including a square-rigged main topsail and topgallant. The warrant omits the gear for those sails, however, and includes the running rigging and blocks needed for a gaff topsail to be rigged on the main topmast.

Bushby's rigging warrant contains the sizes and lengths of the standing and running rigging, and the number and sizes of the associated blocks. From this, it is known that the schooners carried nine sails in their original configuration: flying jib, standing jib, gaff foresail, square sail (foresail), fore topsail, fore topgallant, boom mainsail, main topsail, and main topgallant.

To support these sails, the fore and main masts were each made of a two-part assembly, the lower mast and topmast. The topgallant pole extended from the topmast, but was not a separate piece. In front of the ship, a similar two-part assembly of bowsprit and jibboom made up the basis of the headrig. Chapter III has already discussed how stays, runners, backstays, and shrouds form a network of rigging to support these spars, distribute any strain or load on them, and keep them in place. Shortly after launching in 1815, *Newash's* spars were raised in the following order: main lower mast, fore lower

mast, bowsprit, fore topmast, main topmast, fore yard, main yard, fore and main topsail yards and jibboom.³³²

For this reconstruction, the lengths of the individual sticks were adapted from a series of proportions, based on the treatise of John Fincham, from Howard I. Chapelle's *The Baltimore Clipper*.³³³ Fincham's treatise offered several options for rigging a schooner, and Chapelle created a system of calculations³³⁴ based on similarities between Fincham's various dimensions. Chapelle's ratios were based largely on the extreme breadth of a vessel and her load waterline length. The diameters of the lower masts were taken from Robert Moore's draft of the schooners, and the other spars were extrapolated from these measurements. The taper of the masts was taken from David R. Steel's treatise. The dimensions of the masts and spars can be found in Table 3. The standing rigging was set up with deadeyes and hearts³³⁵ (figs. 38 and 39).

Table 3: Dimensions of Masts

Mast	Length	Maximum Diameter
Foremast	59 feet 8 inches (18.19 m) hounded	17 inches (43.19 cm)
	8 feet (2.44 m) headed	
Fore Topmast	21 feet (6.40 m)	12 inches (30.49 cm)
Fore Topgallant	11 feet (3.35 m)	8 inches (20.33 cm)
Main mast	66 feet (20.12 m) hounded	19 inches (48.27 cm)
	8 feet (2.44 m) headed	
Main Topmast	22 feet 8 inches (6.91 m)	12 inches (30.49 cm)
Main Topgallant	10 feet 6 inches (3.20 m)	8 inches (20.33 cm)
Bowsprit	27 feet (8.23 m)	14 inches (35.57 cm)
Jibboom	27 feet 8 inches (8.43 m)	9.5 inches (24.13 cm)

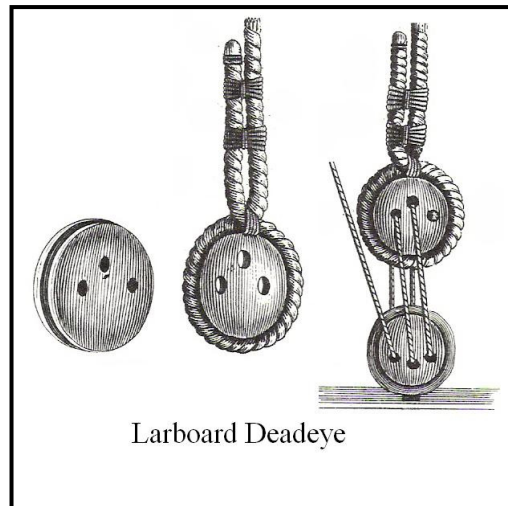

Figure 38: Larboard deadeye.
 (Detail from Darcy Lever, *The Young Sea Officer's Sheet Anchor*, 14, 22, 24, figs. 113, 167, 176.)

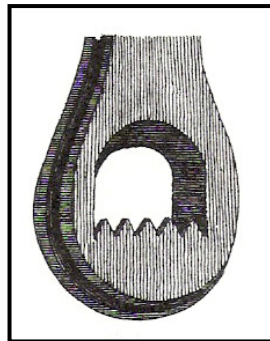

Figure 39: Rigging heart. (Detail from Darcy Lever, *The Young Sea Officer's Sheet Anchor*, 14, fig. 114.)

Main Rigging

The main lower mast itself was raised with the aid of sheers, and placed into the main mast step. The lowest part of the mast is called the heel. In the case of *Newash* and *Tecumseth*, the heels of the masts were roughly shaped to fit into the mortise in the mast steps. Moving upwards from the heel of the mast, the mast passed through a hole in the deck, where it was supported and secured by mast partners and wedges.

The schooner rig presented an interesting challenge in interpreting the main rigging. On a fully square-rigged vessel, the main stay led directly to the deck without interfering with any other sails. Such a stay would have interfered with the proper operation of the fore-and-aft rigged foresail. A stay leading between the heads of the main and fore lower masts would not have the proper downward angle, and would have to be carefully placed to avoid interfering with the operation of the main topsail.

The rigging arrangement proposed here combines these two types of stays. *Newash's* rigging warrant lists a "Main Mast Head Stay"³³⁶ and two "Main Mast Deck Stays," of different size rope. From this, it may be assumed that two stays were rigged from the main lower mast hounds to the deck, one on either side of the ship. The ideal arrangement would have these stays leading as far forward as possible within the confines of the hull. Two 9-inch (22.87 cm)³³⁷ double sheave blocks were rigged to each of the pendants of the deck stays, which allowed the stays to be hove taut or slacked off.³³⁸ These blocks were set up as a two-fold purchase; (fig. 40) four times the

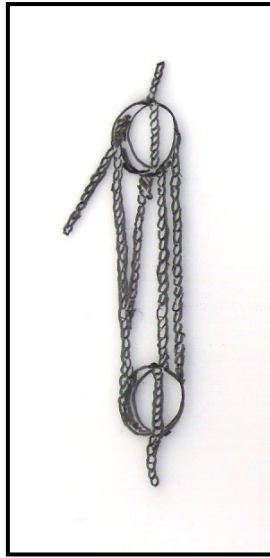

Figure 40: A two-fold purchase.

advantage was gained. When sailing, the leeward deck stay was slackened and moved or nipped out of the way, to avoid cutting into the shape of the foresail. The weather deck stay remained taut, supporting the mast. During tacking or wearing operations, or in cases when both stays were slack, the mast was supported by the mast head stay, which ran between the main and fore lower masts.

The main runners, or breast backstays, opposed the main stays, and were given as much of an aft lead as possible, while remaining within the confines of the hull. These were made of two pieces: a pendant, which led down from the lower mast hounds, and a block and tackle system, which allowed the runner to be tensioned. The end of the pendant was seized around a 9-inch (22.87 cm) single sheave block. A runner line was rove through the sheave of this block, and a 9-inch (22.87 cm) double sheave block was

seized into the end.³³⁹ A single luff purchase was set up with the double sheave and another 9-inch (22.87 cm) single sheave block (see fig. 11). The luff tackle provided triple the power than without purchase.

Moore's drawing of the ships indicates that the mainmast carried three shrouds on each side of the ship.³⁴⁰ The forward two legs on each side were made from the same line, which was middled and seized to form an eye. The after legs were made as single legs, having an eye spliced into the end. Each shroud had a deadeye made into its lower end, which was connected, by a lanyard, to another deadeye attached to the hull of the ship. The shrouds were tensioned with purchase blocks and secured with a lanyard. Each lanyard had a stopper knot, usually a lanyard knot or Matthew Walker knot (fig. 41) tied in one end, and was rove through the holes of the deadeye.³⁴¹ A series of smaller lines tied between each shroud leg provided ratlines for sailors to climb on when working aloft.

Fore Rigging

Rigging the fore lower mast presented less of a challenge than the main, but was not straightforward. Bushby's rigging warrant does not list a fore stay at all. There must have been one, however, for the vessel to sail. James Childs' logbook contains an entry on setting up a "preventer fore stay,"³⁴² indicating that the original fore stay was insufficient, but not that it was absent completely.

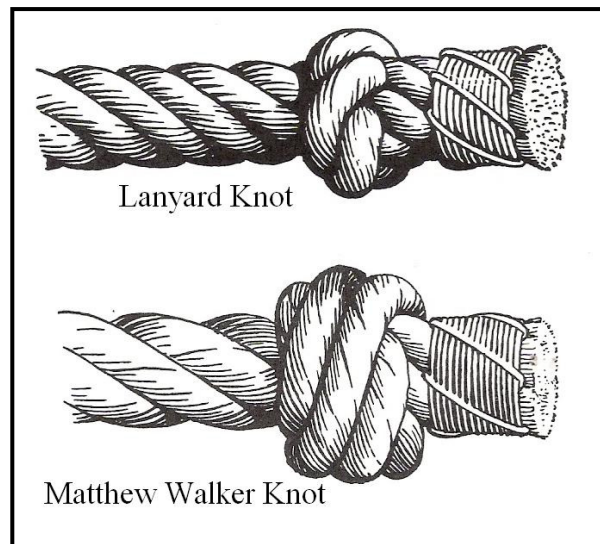

Figure 41: Lanyard and Matthew Walker knots. (Detail from Hervey Garrett Smith, *The Marlinpike Sailor*, 37, 40.)

The primary fore stay was rigged to the end of the bowsprit, ran through bee blocks on the starboard side, just abaft the bowsprit cap, and was secured with hearts to the stem. Since the jibboom was hove out over the bowsprit, the stay was offset to starboard. When *Tecumseth's* preventer fore stay was rigged after the dismasting, it was rigged with a horse collar. The port bee block already accommodated the fore topmast stay, and two stays running through a bee block would have been too much load for the timber. A horse collar set-up used less cordage, material that may have been at a premium during the re-rigging. A horse collar acted in the same manner as a pair of hearts or deadeyes, but allowed space for the jibboom to pass underneath it.

Runners and shrouds were set up like the main lower mast. Runners opposed the stays, and were given an aft orientation, leading to points near the base of the main shrouds.

The fore runners were set up with a runner line and luff tackle. Three pairs of shrouds, as evident from Moore's draft, steadied the fore lower mast laterally.

Bowsprit Rigging

The bowsprit itself can be imagined as a mast that has been leaned forward. Like the main and fore masts, it had stays and shrouds. In this case, the stays were called bobstays, and led to the ship's stem. Unlike the main and fore lower mast stays, which had hearts seized into their lower ends for obvious reasons, bobstays had hearts or deadeyes seized into their upper ends. This prevented the vulnerable lanyard from excess rot caused by immersion in water, and gave the bobstay hearts a clearer lead back onto the deck when they were tensioned.

The rigging warrant lists only one length of cordage for a bobstay, but James Childs' logbook records the plural "bobstays" on several occasions, even before the dismasting.³⁴³ It is probable, then, that two bobstays were set up. Since the bobstays supported the bowsprit by pulling it downward, the lowest lead possible was preferred. Because of the low angle of the bowsprit, this meant placing the bobstay bridles near the waterline. Shortly after she was rerigged, *Tecumseth's* crew shifted her bobstays "a foot [0.30 m] further down."³⁴⁴ This may have meant that the bobstays were submerged – perhaps continually or only periodically.

The hemp standing rigging required some form of covering to keep water and sunlight from destroying the fibers. Rope that was exposed to excess chafe or other elements was coated with tar, then wormed, parcelled and served. A thorough application of tar³⁴⁵ was necessary to keep all standing rigging in shape; tar protected rope from rot due to dampness, but also reduced the rope's flexibility and strength.³⁴⁶ Worming meant winding smaller-diameter line in the crevices of the twisted rope. This gave the rope a nice, solid cylindrical shape. The rope was wrapped with parcelling or pieces of old canvas. Finally, the rope was served: a small-diameter line was wrapped tightly around the rope. In between each step, the material was thoroughly tarred. Parcelling and service added two layers of protection for the rope, and the tar prevented water from penetrating to the rope core.

The lone pair of bowsprit shrouds was set up just like the shrouds on the main and fore masts. With only one shroud on each side and the near-horizontal angle of the bowsprit, it would be impossible and impractical to rig ratlines. On some larger vessels, horses might have been rigged under the bowsprit for men to stand on, but they were not listed in Bushby's rigging warrant. Men needing to work on the bowsprit or further in the headrig probably climbed out on the bowsprit itself. The upper side of the bowsprit might have been planed down to a horizontal surface, to provide better footing for those sailors.

Trestletrees, Crosstrees and Mast Caps

To be properly stayed by the standing rigging, the mast was shaped with an enlarged “shoulder” for the eyes of the rigging to be placed over and tightened against. In addition, since the lower masts supported another mast above, a sufficient place for the standing rig of the topmasts to be secured was made. A pair of timbers, called trestletrees, was placed at the shoulder of the masts, supported underneath by cheeks, which enlarge the fore and aft dimension of the masts. On top of the longitudinal trestletrees, crosstrees were placed, which ran perpendicular to the trestletrees. The tic-tac-toe framework of the trestletrees and crosstrees provided a base to seat the heels of the main and fore topmasts and to secure the deadeyes of the topmast shrouds, as well as other rigging elements.

At the upper ends of the lower masts and outer end of the bowsprit, the topmasts and jibboom were secured with caps. Roughly rectangular in shape, these mastcaps contained a mortise in the after or lower half, for a tenon cut in the lower mast or bowsprit. A circular hole was cut in the other half of the cap, through which the topmast or jibboom was pushed. (fig. 42) This secured the lower mast and topmast, or bowsprit and jibboom, to one another. The overlap of the two masts was called the “doubling.”

Topmast Rigging

With the lower rig in place, the topmasts were swayed. To avoid overburdening the ship with a heavy rig aloft, the topmasts were smaller in dimensions than the lower masts, the

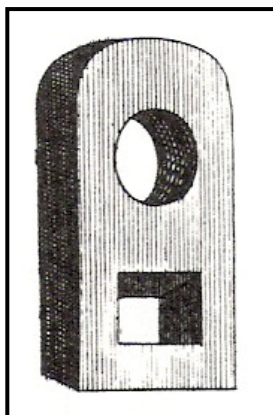

Figure 42: Mast cap.
 (Detail from Darcy
 Lever, *The Young Sea
 Officer's Sheet
 Anchor*, 26, fig. 185.)

standing rigging was smaller and there were fewer pieces. The fore and main topmasts had only two shrouds on each side, one stay leading forward and a pair of backstays. The fore topmast also had a flying jib stay, which will be considered a bit later.

The main topmast stay led to the hounds of the fore lower mast. The topmasts were not secured to each other; either could be swayed up or taken down independent of the other. The main topmast backstays fell at a plumb line, perpendicular to the load waterline from Moore's draft, and are secured at the outside of the hull. As with the lower shrouds, the lower ends of the topmast shrouds were seized around a deadeye, and a corresponding deadeye was secured at the crosstrees. To keep the full strain of the topmast shrouds from falling on the crosstrees alone, futtock shrouds were rigged. These were short lengths of rope that ran from the underside of the lower topmast deadeyes to a wooden beam or batten, called the futtock stave, which was secured to the

lower shrouds below. Tension on the topmast shrouds transferred through the deadeyes and lanyards to the futtock and lower shrouds.

The strain of the topmast rigging on the futtock stave had a tendency to cause the lower shrouds to bulge outward. To prevent this from distorting the shape of the lower rig, catharpins were rigged. These were horizontal lines, which ran abaft the fore and main lower masts, between the port and starboard shroud legs. Onboard *Tecumseth* and *Newash*, the lower shrouds were swiftered in tightly before the catharpins were seized in place.³⁴⁷ To do this, a line called a swifter was rove between the shroud legs, and hove taut to pull the legs inboard³⁴⁸ (fig. 43). Catharpin legs could be cut and spliced to a specified size, and seized in place between the lower shroud legs. When the swifter was released, the catharpins remained under strain. The tension of the catharpins resisted the outward pull of the topmast and futtock shrouds.

The fore topmast was rigged in the same manner as the main topmast. The fore topmast backstays fell at a plumb line to the hull. The shrouds were secured with deadeyes, futtock shrouds, futtock staves and catharpins. Since the jibboom was not yet run out, the fore topmast stay was led to the end of the bowsprit, running through the starboard beeblock, opposite the fore stay. It was secured to the hull of the ship near the stem.

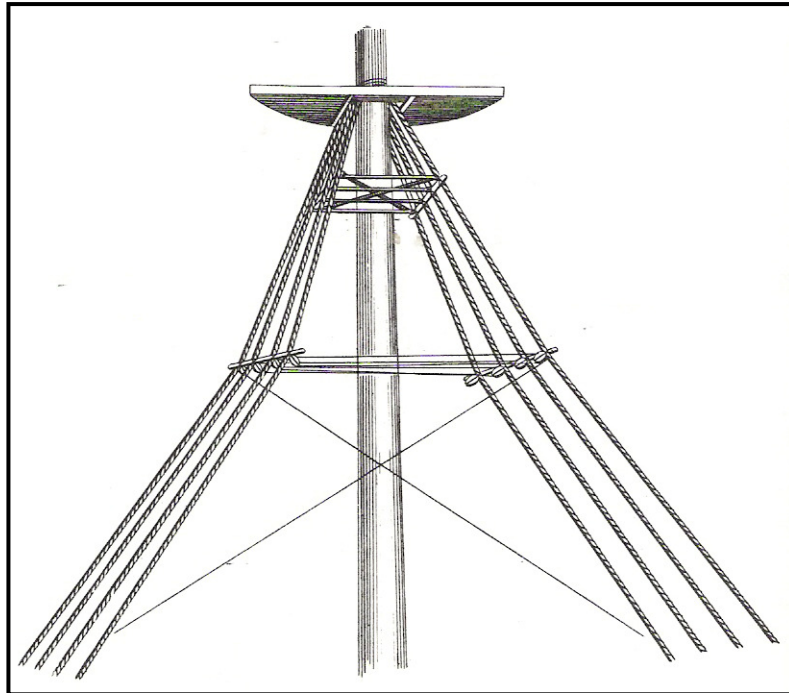

Figure 43: Swifftering in shrouds. (Detail from Darcy Lever, *The Young Sea Officer's Sheet Anchor*, 25, fig. 182.)

Topgallant Rigging

Since the topmasts and topgallantmasts were made from the same pieces of wood, the topgallant standing rigging was placed before the topmasts were completely in place. The rigging was not tensioned, however, until after the topmast rigging had been secured. Again, being higher in the rig, the topgallantmasts were a smaller diameter than the top and lower masts below them, and had less rigging. In the case of *Tecumseth* and *Newash*, the main and fore topgallantmasts had one stay and two backstays, but no shrouds. The topgallant sails were not permanently rigged but were set from the decks. Without the weight of a topgallant yard and sail aloft, the support of additional standing rigging was not needed.

The main topgallant stay led to the fore lower mast cap, and was secured at the fore trestletrees. The main topgallant backstays fell at a plumb line to the hull, where they were secured with deadeyes. The fore topgallant stay led to the end of the jibboom, and could only be tensioned once the jibboom was securely in place. The fore topgallant backstays also fell at a plumb line to the hull and were secured there.

A short pole stuck out above each topgallant mast. No sails were set on this pole, but a flag halyard was placed at the truck of the mast and used to hoist signal flags. These flags were used to communicate between vessels.

Jibboom Rigging

After the topmasts were swayed, the jibboom was rigged. Before it could be secured, a martingale had to be made and placed. This was a short spar which projected downward from the forward side of the bowsprit cap, and was raised just before the jibboom was run out. Because of the low angle and long length of the bowsprit and jibboom, it would be very difficult to get a downward pull on jibboom stays. By adding the martingale, and running rigging through holes in its lower end, a better angle could be achieved. Perhaps counterintuitively, the line that runs from the end of the jibboom, through the martingale and back to the hull was not called a jibboom stay but a martingale stay.

The jibboom had two shrouds – one on each side of the ship – secured to the hull. The jibboom also supported the fore topgallantmast. The fore topgallant stay ran through a

notch, or dumb sheave, in the end of the jibboom,³⁴⁹ through the martingale, and was secured to the hull. The inboard end of the jibboom had to be secured as well, to prevent the boom from sliding down the bowsprit. A heel rope and heel lashing were used for this purpose.

The flying jib stay occupies a curious point in this discussion of the rigging. Having a separate stay for the setting of the flying jib prevented the strain of the sail from falling on any other piece of the rig. An iron ring, or traveler, was placed over the jibboom before it was hove out. The traveler was circular in shape, with a thimble or shackle attached at its upper side (fig. 44).³⁵⁰ The flying jib stay ran through this upper ring and through a sheave in the jibboom. Aloft, the stay ran through a 6-inch (15.24 cm) single sheave block at the fore topmast hounds. At either end of the stay, two more 6-inch (15.24 cm) single sheave blocks were secured. A separate line ran through those blocks and another to create a gun tackle purchase at both ends.³⁵¹ The tackles meant that the flying jib stay could be tensioned from its upper or lower end, and the traveler allowed the stay to be moved along the length of the jibboom. This also meant that the entire jibboom could be moved inboard, toward the bow of the ship. Two occasions recorded in Lieutenant Kent's logbook, kept aboard *Newash* in 1816 and 1817, mention that the crew "eased the jib half boom in," and "eased the jib in."³⁵² Bringing in the jibboom might have also been done when the fore topmast was struck, to avoid having a large, unsecured spar projecting from the hull.

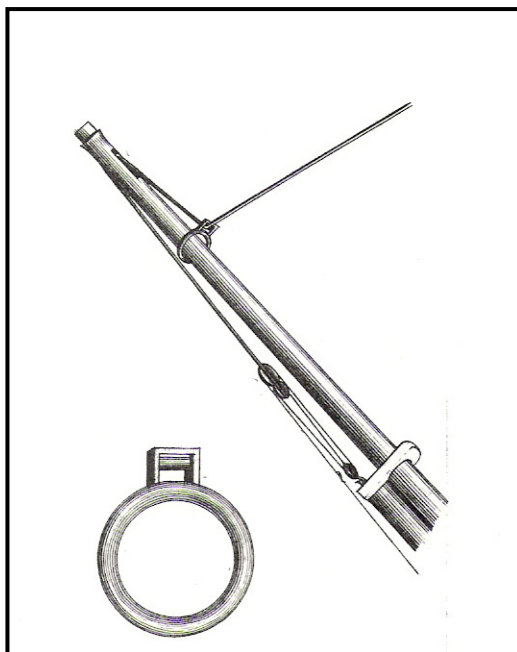

Figure 44: Flying jib stay set-up with traveler ring. (Detail from Darcy Lever, *The Young Sea Officer's Sheet Anchor*, 60, figs. 333, 334.)

It is important to note that the spars have been drawn in an optimal configuration, which is not necessarily true to life. In actuality, the upward pull of the flying jib had a tendency to raise the outer end of the jibboom. To counteract this, the jibboom would have been rigged with a downward steeve, which has not been shown.

Main Yards and Spars

The dimensions of the yards were taken from John Fincham's treatise. The lengths of the yards on the fore and main masts are identical, although the difference in mast heights yields larger sails on the main mast. The yards, gaffs and booms all share some

similar characteristics, both to each other and to other ships of the period, but each is rigged slightly different. To best illustrate the differences between the spars and the peculiarities of the rig, the yards and spars will be considered by mast (Table 4).

Table 4: Dimensions of Yards and Spars

What	Maximum Diameter	Length
Main/Fore Yards ³⁵³	10 inches (25.41 cm)	38.50 ft, 1.67 ft arm
Main/Fore topsail yards	8 inches (20.33 cm)	31.17 ft, 2.83 ft arm
Main/Fore topgallant yards	6 inches (15.24 cm)	22.75 ft, .92 ft arm
Main Gaff	10 inches (25.41 cm)	24.75 ft
Main Boom	12 inches (30.49 cm)	46.33 ft
Fore Gaff	10 inches (25.41 cm)	22.45 ft

The mainsail was a hoisting sail. The sail stretched between a gaff at the head, or top, of the sail, and a boom at the foot, or bottom. The gaff was raised with two halyards, a throat halyard and a peak halyard (fig. 45). The throat halyard assembly included one 9-inch (22.87 cm) double sheave block and one 9-inch (22.87 cm) single sheave block.³⁵⁴ The double sheave block was lashed to the underside of the main trestletrees and the single block was lashed to the main gaff. This arrangement could provide three times the hauling power. The peak halyard was hauled at the same time as the throat halyard to raise the sail. The peak halyard was rigged with an 8-inch (20.33 cm) double sheave block and an 8-inch (20.33 cm) single sheave block.³⁵⁵ To allow the peak of the gaff to be raised higher than the throat, the double sheave block was secured to the after side of the main mast. The single sheave block was attached to the gaff, approximately three-quarters of the way to the end. The end of the halyard itself was made off to the end of

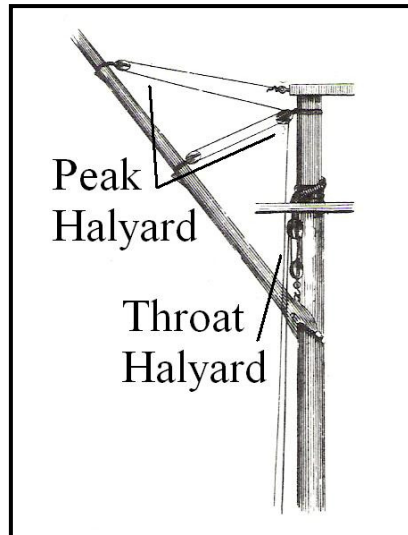

Figure 45: Throat and peak halyard assemblies. (Detail from Darcy Lever, *The Young Sea Officer's Sheet Anchor*, 43, fig. 266.)

the gaff. This arrangement of blocks was similar to the double whip type of purchase, where twice the power is gained.

To keep the gaff under control when lowering the sail, both the throat and the peak had a downhaul. Each downhaul utilized a 6-inch (15.24 cm) block and line of approximately 0.50-inch (1.27 cm) diameter.³⁵⁶ The throat downhaul block was a single sheave block while the peak downhaul block had two sheaves. The extra sheave was probably not for purchase but for a separate flag halyard to be rove. It was not common practice to fly the Royal Ensign at all times when underway, but the schooners could display it when they needed to identify themselves as Royal Navy vessels. When the mainsail was set,

the end of the gaff was the highest, furthest aft point from which the ensign could be flown.

Because the main gaff was hoisted to a fairly regular position, a spot of chafe appeared on the mast from the transverse motion of the gaff. To prevent this chafe from creating a weak spot in the mast, one or more pieces of copper were placed around the mast at that point.³⁵⁷ The copper generally had to be greased, which also kept the gaff from squealing. The jaws of the gaff were sheathed in leather for this same purpose.³⁵⁸ The rest of the main lower mast was greased as well, to ensure easy motion of the main gaff when setting and taking in the mainsail.³⁵⁹

The main boom stretched the bottom, or foot, of the mainsail. When the sail was not set, the boom remained stationary, about 6 feet (1.83 m) off the deck. When the sail was set, the end of the boom was raised with topping lifts. The topping lifts (fig. 46) also allowed the main boom to be used for lifting cargo, if desired.

The boom topping lift was made in three parts. A thicker rope, approximately 1.25 inches (3.18 cm) in diameter, was hitched around the end of the boom and rove through two single sheave blocks lashed to the underside of the mainmast trestletrees, one on each side. Each end of the lifts was seized around an 8-inch (20.33 cm) double sheave block. Both topping lift falls were rove, with smaller rope, as a single luff tackle

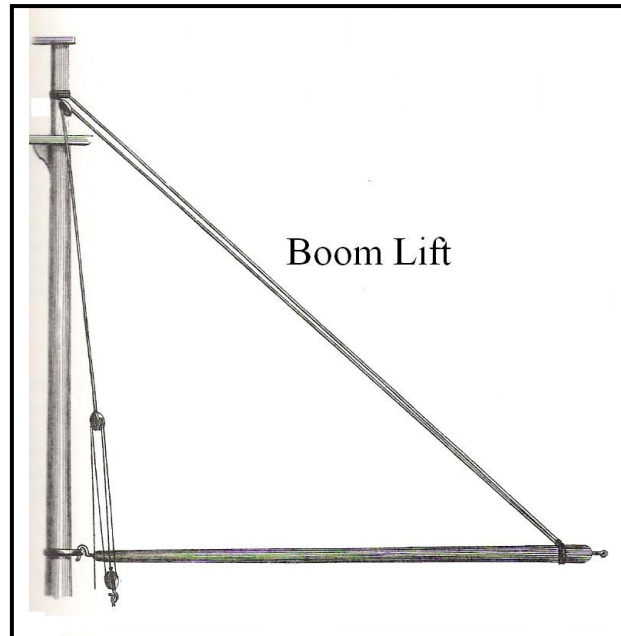

Figure 46: Boom lift assemblies. (Detail from Darcy Lever, *The Young Sea Officer's Sheet Anchor*, 44, fig. 269.)

between the double sheave block and an 8-inch (20.33 cm) single sheave block lashed on deck.

When the mainsail was set, the leeward lift was slackened, to allow the sail to fill naturally. The weather lift remained taut to prevent the boom from falling if the wind suddenly shifted or died. To make slacking the leeward lift easier, a lazy guy was rigged. This was a line that ran through a block made along the run of the topping lift³⁶⁰ (fig. 47). When this line was hauled on, the topping lift would become slack faster and easier than if the line were simply left hanging loose. The lazy guys ran through 8-inch (20.33 cm) blocks.³⁶¹ Like the peak downhaul, one of the blocks had a single sheave

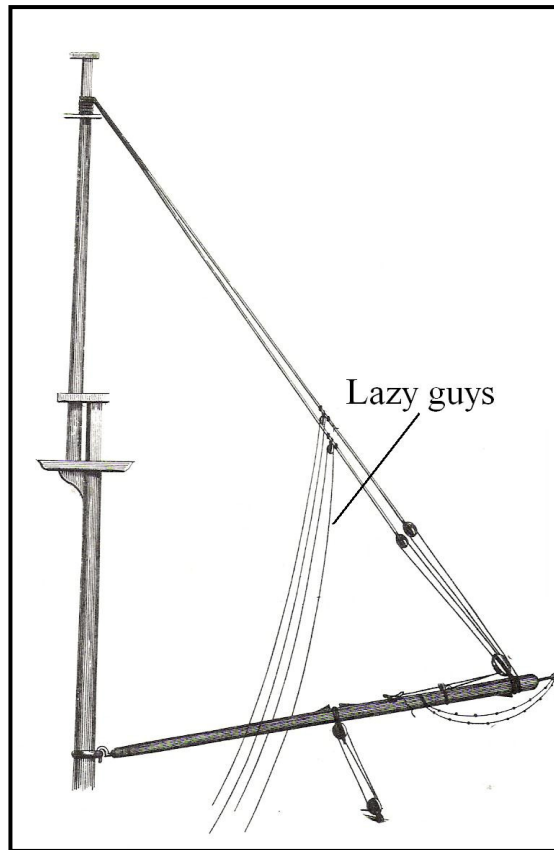

Figure 47: Lazy guy assemblies.
(Detail from Darcy Lever, *The Young
Sea Officer's Sheet Anchor*, 44,
fig. 268.)

while the other was a double sheave block. The double sheave block carried a separate halyard for a Royal Navy ensign to be raised, in times when the main sail was not set.

Above the main gaff, the main yard was hoisted, and remained relatively fixed. The center of the yard was lashed to a line running around the hounds of the main mast, called a sling.³⁶² Lines called trusses helped pull the yard in toward the mast. In some situations, this was desirable while in others, the trusses were eased off. The ends of the yard were supported with lifts. The lifts were hitched around the ends of the yards, then led upward, over the mast cap and down through the trestle and cross trees on the opposite side.³⁶³ Two 6-inch (15.24 cm) single sheave blocks and two 8-inch (20.33 cm) double sheave blocks were also used in the fore lift assemblies,³⁶⁴ which would allow them to be rigged with a fall having the now familiar single luff purchase.

The lifts (fig. 48) supported the ends of the yardarms, and allowed the yards to be kept level to the horizon or cockbilled if necessary. This way, the yards could be used to bring heavy cargo onboard, with the yard acting like a crane. The yard lifts could also be used to help achieve proper sail shape. Hauling on the leeward lift lowered the weather yardarm. When a stack of square sails was set, this helped stretch the weather edges of the canvas. As previously mentioned, maintaining tension along the edges of a sail was paramount to its proper operation.

Also attached to the ends of the yardarms were braces. Braces were placed on both yardarms, and were usually set up in opposition to one another. By hauling on one brace and easing the other, the yard was essentially rotated around the mast. Changing the angle at which the yards encountered the wind gave the schooners a wider arc of favorable winds than if the yards were left in their original orientation. The amount that the yards can be braced up is limited, however, by the stays and shrouds of their respective masts. As a yard rotates around the mast, it will encounter, and lay heavily upon, the forward leg of the shrouds and the stay.

Only two 6-inch (15.24 cm) single sheave blocks were used in the brace assemblies, and were placed in the foremast rigging to act as turning blocks. The main braces were

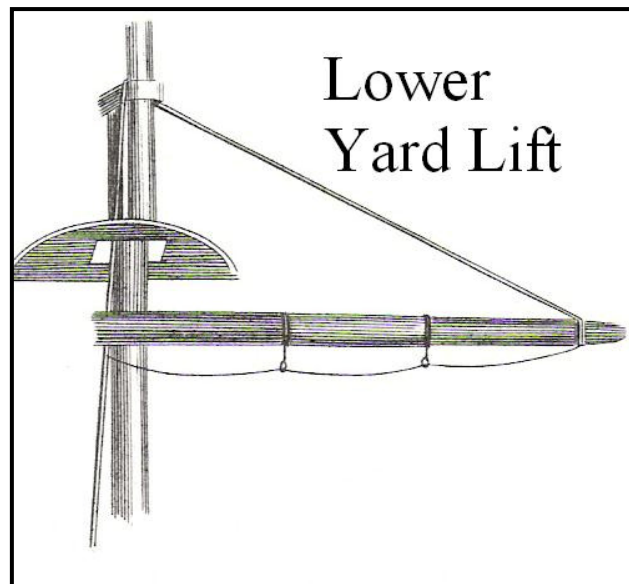

Figure 48: Lower yard lift assemblies.
(Detail from Darcy Lever, *The Young Sea Officer's Sheet Anchor*, 34, fig. 221.)

hitched around the main yard, led forward to the fore rigging, ran through the single sheave turning blocks and down to the deck.

To allow sailors to work along them, footropes or horses were run under the yards.

These gave the men a secure footing when working aloft. The footropes were suspended from stirrups placed at each quarter of the yard on either side, and were laced between them. There was no square sail set on the main yard, but if the yards were used for raising cargo, a footrope would be needed to reach the yardarm.

The topsail yard was crossed on the main topmast. Unlike the main yard, the main topsail yard had to be raised in order to stretch the main topsail. It was rigged with a halyard, which hoisted the yard, and lifts, which supported the yardarms. Unlike the lifts on the main yard, the main topsail yard lifts were not rigged with tackles leading to the deck. It is likely that these lifts were hitched around the yardarms, ran through a single block and were secured to the trestle or crosstrees or lower mast cap. The rigging warrant gives the dimensions for the cordage³⁶⁵ of the topsail lifts, but does not list any blocks for these. The cordage used, of approximately 0.75-inch (1.91 cm) diameter, seems large for a simple thimble,³⁶⁶ and so sister blocks (fig. 49) have been shown here, seized between the legs of the two topmast shrouds.³⁶⁷

Footropes or horses were rigged on the main topsail yard like the main yard below. The stirrups were fixed at approximate thirds across each side of the yard, however, since the topsail yard was shorter than the main yard.

Both fore and main topgallants were set flying, or from the deck, which meant that there was no standing rigging for these yards. The halyards that hoisted the yards ran through a sheave in the topgallant mast and both ends ran to the deck. To set the sail, the halyard was tied to the center of the yard. A downhaul was also attached, usually at one yardarm. When it was necessary to brace up or in, the topgallant yards simply followed the topsail yards around, since they had no braces of their own.

Fore Yards and Spars

The foresail, like the mainsail, was a fore-and-aft rigged sail, though it was not rigged to hoist like the main. Instead, the fore gaff was raised and the sail brailed in to the gaff and the fore mast. The fore was loose-footed and did not have a boom. Without a boom, there was no need for topping lifts or lazy jacks. The gaff still required a throat and peak halyard to hoist it into proper position. These were set up similarly to those on the main, with the same arrangement of blocks, though the sizes were slightly different. The fore throat and peak halyards ran through 9-inch (22.87 cm) blocks, where the main had used 8-inch (20.33 cm) blocks.³⁶⁸ This may have been a matter of available materials, since each halyard was made of 0.75-inch (1.91 cm) diameter line.³⁶⁹ Unlike the main gaff, the fore gaff did not have peak and throat downhauls, since it was now lowered each time the sail was taken in.

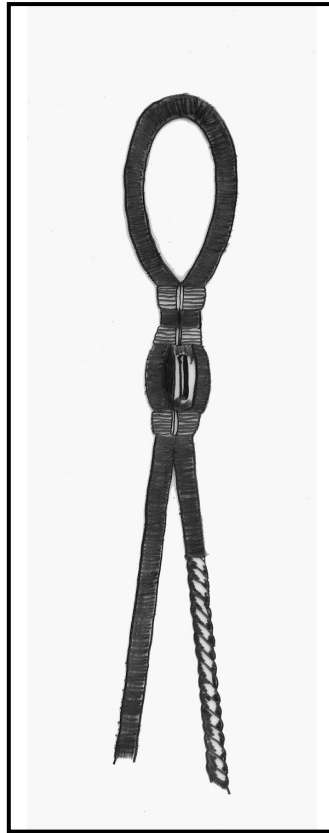

Figure 49: Sister
block. (Detail
from Darcy Lever,
*The Young Sea
Officer's Sheet
Anchor*, 27,
fig. 191.)

The foreyard was rigged in a manner similar to the main yard. The yard was secured with slings at the center, leveled with lifts at the yardarms, and squared or angled to the mast with braces, which led to the mainmast. The foreyard was also hauled in towards the mast with trusses, and footropes ran underneath to support sailors.

The fore lower mast did carry a square sail, unlike the main lower mast, and Bushby's rigging warrant lists both slings for the yard and a halyard for the sail. This would seem redundant, since the slings would already support the bulk of the yard and sail. The halyard may have been rigged for ease in lowering the yard, rather than hoisting it. The rigging warrant lists only a 6-inch (15.24 cm) single sheave block. This is a rather small block for the size of the yard, and the line used was only approximately 0.625 inch (1.59 cm) in diameter. Ninety fathoms (540 feet or 164.63 m) of line were available, though.³⁷⁰ It is possible that the halyard was secured around the mast at the hounds, then led through a block on the foreyard, through a sheave in the mast, and to the deck.³⁷¹

The fore topsail yard was rigged in a similar manner to the main topsail yard, with a halyard, lifts, and braces. The topgallant yard was again set from deck, with a halyard and downhaul. As on the main, the topgallant yard followed the topsail yard when bracing up or in.

Running Rigging

Some of the running rigging has already been discussed, such as halyards for the gaff sails, and lifts and braces for the square sails. These were not the only lines which were used for the setting and adjusting of these sails, though. Most lines used as running rigging occur in pairs that oppose one another. We have already seen how halyards and downhauls can be attached to the same point on a spar but work in opposite ways. Most running rigging has this sort of opponent.

Halyards are used for raising a sail, regardless of whether this involves a yard, gaff, or neither. On some sails, as we have seen, the halyard is opposed by a downhaul. On fore-and-aft sails, sheets control the attitude. The attitude may be seen as the way in which a sail encounters the wind. There is, of course, an optimal way in which a sail encounters and uses the wind, for maximum effect. This can be achieved by proper trimming of the sail using the sheet. On fore-and-aft sails, the sheets perform much the same function as the braces on a square sail. A square sail still has sheets, however. On a square sail, sheets are used to pull the bottom corners of the sail down towards the deck, often to the ends of the yardarm below.

Square sails also had several other types of running rigging. One line, called a clueline, opposed both the halyard and sheet. A clueline ran to the bottom corner, or clue³⁷² of the sail (fig. 50). When the sheet was in operation, drawing the clue down, the clueline was

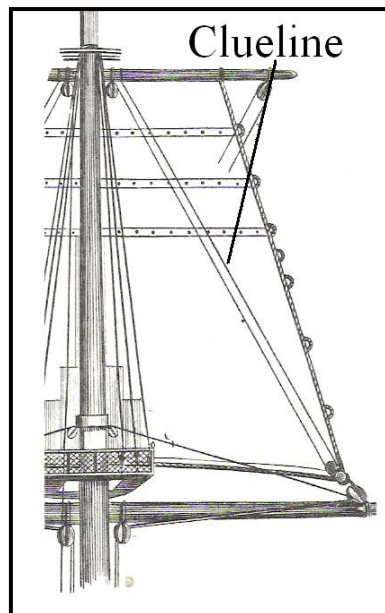

Figure 50: Topsail showing cluelines rigged. (Detail from Darcy Lever, *The Young Sea Officer's Sheet Anchor*, 56, fig. 317.)

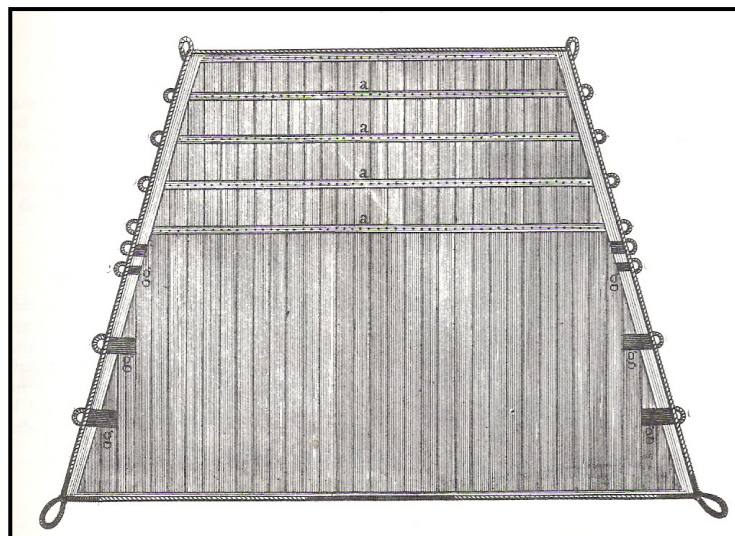

Figure 51: Topsail showing cringles. (Detail from Darcy Lever, *The Young Sea Officer's Sheet Anchor*, 54, fig. 308.)

left slack. To bring a sail back in, the opposite was done: the sheet was left slack and the clueline was hauled on, which brought the clues back up to the yardarm. The clueline was usually rove through a block near the center of a yard, or a short distance outboard on both sides. Because the line ran through a block attached to the yard, it could also be used to oppose the halyard. If the sheets were left taut, hauling on the clueline actually pulled the yard down. *Newash* and *Tecumseth*'s original rigging configuration included cluelines on the topsails but not topgallants. Since the topgallants were set from deck, it was not necessary to have multiple lines that could bring the sail in.

Just as lifts and braces could be used to keep the weather edge of a square sail tight, lines called bowlines could also be used for this same purpose. Bowlines were comprised of several short lines called bridles, which are rove through cringles at the vertical edges of a square sail (fig. 51). Cringles were semi-circles of rope which are attached to the boltrope, a rope sewn along the edges of a sail. Near the head of the sail, cringles corresponded with reef bands. On the lower parts of the sail, cringles were used for bowline bridles. There was always one more cringle than there were bridles. The first bridle was rove through an eye in the second bridle, and the ends of the first were attached to the highest two bowline cringles. The second bridle, one end being a splice to accommodate the first bridle, was rove through an eye in the third bridle and attached to the third cringle. Any additional bridges were rove in the same manner. Finally, the last bridle was not attached to the sail at all; an eye at one end accommodated the previous bridle, and the line ran parallel to the fore topmast stay, through a block at the

bowsprit cap, and was hauled on and made fast on deck³⁷³ (fig. 52). When sailing, the weather bowline was tensioned, stretching the weather edge of the sail, while the other bowline was left slack.

One type of running rigging which was curiously absent from Bushby's rigging warrant were buntlines. These were lines that took in square sails. There were an equal number of buntlines on the port and starboard sides of the sail. Some large square sails may have had two or more buntlines, but smaller sails did not need as many. A buntline was tied to the bottom edge of a square sail, which was also called the "bunt." From the bunt, the line ran through one or more thimbles, which were small doughnut-shaped pieces of wood sewn into the forward side of a sail. The buntline then ran through a

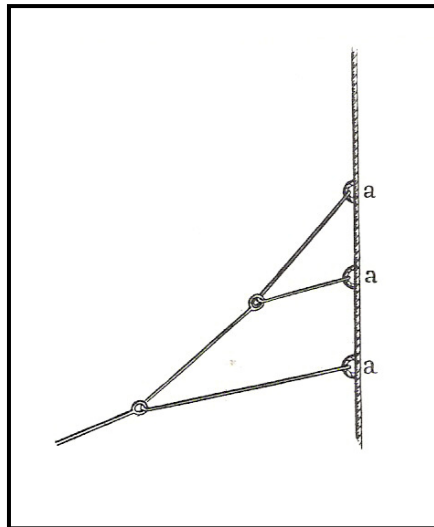

Figure 52: Bowline assembly.
(Detail from Darcy Lever, *The Young Sea Officer's Sheet Anchor*, 57, fig. 321.)

turning block placed high in the rigging, and down to the deck. When the sail was being set, buntlines were left slack, but they were used to take the sail in. Once a square sail's halyard had been eased, hauling on the buntlines brought the bulk of the canvas up to the yard. This would have made it easier for sailors to furl the sails, as there was less canvas left to billow and blow about. Buntlines do not appear on Bushby's rigging warrant. The small size of the square sails on *Tecumseth* and *Newash* may have made buntlines unnecessary.

The original rigging configuration of *Tecumseth* and *Newash* included topgallant sails which were set flying. The yards were not fixed to the masts, but were hauled from the deck each time the sail was set. To accomplish this, the sail had a halyard and sheets as well as a downhaul. The downhaul was likely attached at one of the yardarms. The halyard was bent to the center of the yard, and nipped about halfway out the opposite yard arm from where the downhaul was tied. Nipping the halyard off in this manner allowed the yard to be hauled aloft in a vertical orientation. As the yard neared its hoisted location, the nipper was untied and the yard crossed to a horizontal position. The sails' sheets were probably bent onto the sail when it was aloft, which allowed the topgallants to set properly. To take the sail in, the sheets were untied, the halyard eased and the downhaul hauled on until the sail and yard were once again on the deck.

Another interesting configuration in the original sail plan of the schooners can be found when comparing the gaff-rigged main and foresails. Both were fore-and-aft sails

suspended from gaffs, which were hoisted with throat and peak halyards. The bottom edge, or foot, of the foresail was not attached to any other spar, while the foot of the mainsail was attached to the main boom. This meant that the entirety of the mainsail and gaff had to be hoisted each time the sail was set. The sheet was attached to the boom, which controlled the attitude of the sail. The foresail, however, in its loose-footed configuration, was set and taken in with several lines called brails. These were small lines tied off at various points of the after edge, or leech, of the sail. The lines led back toward the foremast and ran through turning blocks to the deck. When the brails were hauled on, the foresail could be drawn up and into the foremast, much like a stage curtain can be drawn back. Because the gaff generally remained in a hoisted location, two lines called vang were used to control its movement. The vangs were tied to the gaff and led to a tackle at deck level. Tension or slack of these vangs allowed the gaff to pass from one side of the vessel to the other, or kept it secured parallel to the ship's centerline.

Discussion: Rigging and Manpower

Much of this rigging reconstruction is speculative. No records of the actual dimensions of the vessels' masts and spars could be found, though it is known that such documents once existed.³⁷⁴ Thomas Bushby's rigging warrant, however, provides an excellent base for such speculation. One thing that can be interpreted with a measure of certainty from the rigging warrant is the way that purchase blocks were used on board.

Single sheave blocks were used much more frequently than double sheave blocks, which limit, to some degree, the possible setup of the rigging. With 30 men on board the schooners, there was little shortage of muscle power, and purchase blocks were not frequently needed. The opposite may have been true for a similarly-sized merchant ship. Unlike a naval vessel, which had a large crew of contracted men, a merchant venture preferred a small crew. Fewer men consumed less water and provisions, occupied less precious space within the hull and cost the vessel's owners less in wages.

Rigs, just like hulls, were designed for specific functions. Within the vehicles that a car-buyer can choose from are dozens of different types of engines. The same is true for ships. Some engines seem to be a better fit with certain types of vehicles, while others are fairly universal. In the same manner, some features of ship rigs match some hull features better than others. It would not make much sense to put a small engine in a large truck, just as it would not make sense to put a small, short rig on a large vessel, or an enormous pile of canvas on a tiny, shallow hull.

For the sake of argument, an ideal sail plan might have consisted of one extremely large sail.³⁷⁵ The sail must, of course, be massive to utilize the maximum amount of available wind. One obvious problem of this utopian sail plan was that such a sail would be so heavy that it would require an enormous crew to set or handle it. The vessel might well be full of men alone, without any room for cargo, guns or anything else, just to deal with this sail. One obvious way to alleviate this problem was to split the sail into several

smaller sails, on more than one mast. Each sail uses less canvas, less wood, and required less manpower.

Of course, this could be taken to the opposite extreme. A ship could be rigged with dozens, even hundreds, of sails small enough to be set by one man alone. Since this one man could only set one sail at a time, quick maneuvers would be out of the question. This might have been acceptable in merchant sailing, where tacking and wearing did not usually happen at a moment's notice. Naval craft, however, needed to be nimble to engage and evade an enemy.

Some of the small sails could be combined into a few larger ones, and purchase blocks added to their rigging, which would multiply an individual's power. This would permit a sailor to set fewer, larger sails on his own, which quickened his ability to maneuver. The trick in designing a rig, then, was to find a balance between sail area, the number of sails, and the available manpower.

Tecumseth and *Newash* were Royal Navy vessels with large crews of 30 men. They could set large sails, and handle them efficiently without the need for extra purchase blocks. The number of men on board meant that quick maneuvers could be accomplished, if needed. The rigging configurations were designed for their specific hulls, hull characteristics and vessel purposes. To this end as well, the sails themselves

were made – and later altered – for optimal performance under the specific conditions of the hulls, rigging and environment.

CHAPTER XIII

SAILS AND SAILING

From the rigging plan, it is apparent that these vessels were capable of carrying a tremendous amount of canvas, especially considering the sharpness and shallowness of the hull beneath it. The total sail area may be somewhat misleading, however, as there were few occasions when all canvas was piled on and many more occasions when sails were taken in or reefed.

When sailing on the Great Lakes, flexibility in terms of sail area was arguably more important than simple sail area alone. Unlike some other parts of the world with predominant patterns, the Great Lakes are prone to all types of weather. The months of October and November bring squalls, strong winds and high seas. The spring carries the same dangers. The summer can bring months of near-calm conditions. Sailing ships operating on these waters for an extended period of time needed a certain amount of flexibility, in terms of sail area, windage and weight aloft, in their rigs. When sailing in the autumn months, a lofty rig was undesirable. Sail area was kept to a minimum, and the most universal sails were those that set low and close to the center of the ship. In the summer, when facing calm seas and light breezes, sailors set nearly every stitch of canvas they could. Occasionally, the sails highest in the rig could catch a breeze that could not even be felt at the water's level. In these cases, the highest sails and those furthest from the center of the ship were necessary.

A good working sail plan might have included the mainsail, foresail, standing jib and fore and main topsails. In lighter winds or to increase speed topgallants and flying jib were added. The square sail was used when running before the wind. As winds increased sail area was reduced, from the outer edges and working inward. Topgallants and flying jib were taken in. The topsails were reefed or taken in entirely. Reefs could be taken in the lower sails as well.

In the original sails, there were two reef bands in the topsails, two in the foresail, and at least one in the mainsail. During the winter of 1815 – 1816, sailors on *Tecumseth* were busy making points for several new reef bands. Points are small pieces of line used to secure the unused part of the sail. A sailmaker added “a balanced Reef in the Mainsail,”³⁷⁶ third and fourth reef bands in the foresail, two reefs in the standing jib, a third reef in the fore topsail, and a reef in the square sail.³⁷⁷ An abundance of reefs allowed the lieutenants commanding the schooners even more control over the amount of canvas that was set.

Reefing reduces the size of a single sail by essentially folding or rolling one edge and securing it. The secured edge becomes the new top or bottom of the sail. On the main and foresails and the standing jib, the bottom edge is rolled up and tied off, creating a new foot of the sail. On the fore and main topsails, the top of the sail is rolled up and tied off. A line is run through the upper cringles along the edge of the sail, which draw

those cringles up and out to the yard above, creating a new head of the sail. A fold of sail is created by the excess canvas, which is rolled or folded and secured to the yard. Short lengths of small-diameter line, called reef points, are sewn into the sail. One end of the line is apparent on the front of the sail while the other appears at the back of the sail. These reef points are used to secure the excess canvas and keep the head of the reefed sail taut. In these cases, reefing means that a smaller sail will be set closer to the center of the hull. The square sail could also be reefed by rolling up and tying off the upper edge of the sail, but the sail was set at the same height, unless the yard was lowered.

On the fore-and-aft sails, the bottom edge, or foot, of the sails was reduced. To do this on the foresail, the gaff had to be lowered so that the foot could be secured. Unlike the topsails, which had a yard to secure the new head of the sail, the new foot was secured to itself, by rolling the excess canvas and tying reef points around it. Cringles at the leech of the sail were lashed to each other to ensure that the sheet could still function. The mainsail was reefed in a similar manner to the foresail, except that the excess canvas was tied to the boom and the clue of the sail was secured with a reef tackle.

The addition of so many reef bands was probably the result of observations made during the first sailing season. Not only had *Tecumseth* dismasted in a squall in September, but just two months later the schooner was caught in another. Second Master Childs observed the schooner in “Heavy Gales...riding heavy Bowsprite [sic] and Main Boom

under every Dip Sea making a Complete Breach over us.”³⁷⁸ Increasing weather conditions, particularly towards the end of the sailing season, warranted additional compensating changes in the rig.

In addition to reef points, which aided in reducing sail area, both vessels were fitted with a topmast studdingsail, or stuns'l, after the 1815 season.³⁷⁹ This sail was a tall and narrow sail that set beside the fore topsail, usually to the weather side. Adding a studdingsail to the sail plan gave the vessel more sail area to work with, when winds were very light or speed was essential. It does not appear that these sails were used very often.

Sail Plan and Area

For analysis, a hypothetical sail plan was drawn,³⁸⁰ including all nine sails (fig. 53). The sail area of each of the sails was calculated, as well as the total (Table 5). The total sail area of the plan was calculated to be 7284.50 square feet (677.00 m²). This is not necessarily an accurate representation of the sail area that would be used, since it includes both the foresail and square sail, which were not commonly used together, although there were occasions when all possible sail was set. Without the square sail, the sail area is 5904.50 square feet (548.75 m²). Without the foresail, the sail area was 6023.50 square feet (559.80 m²).

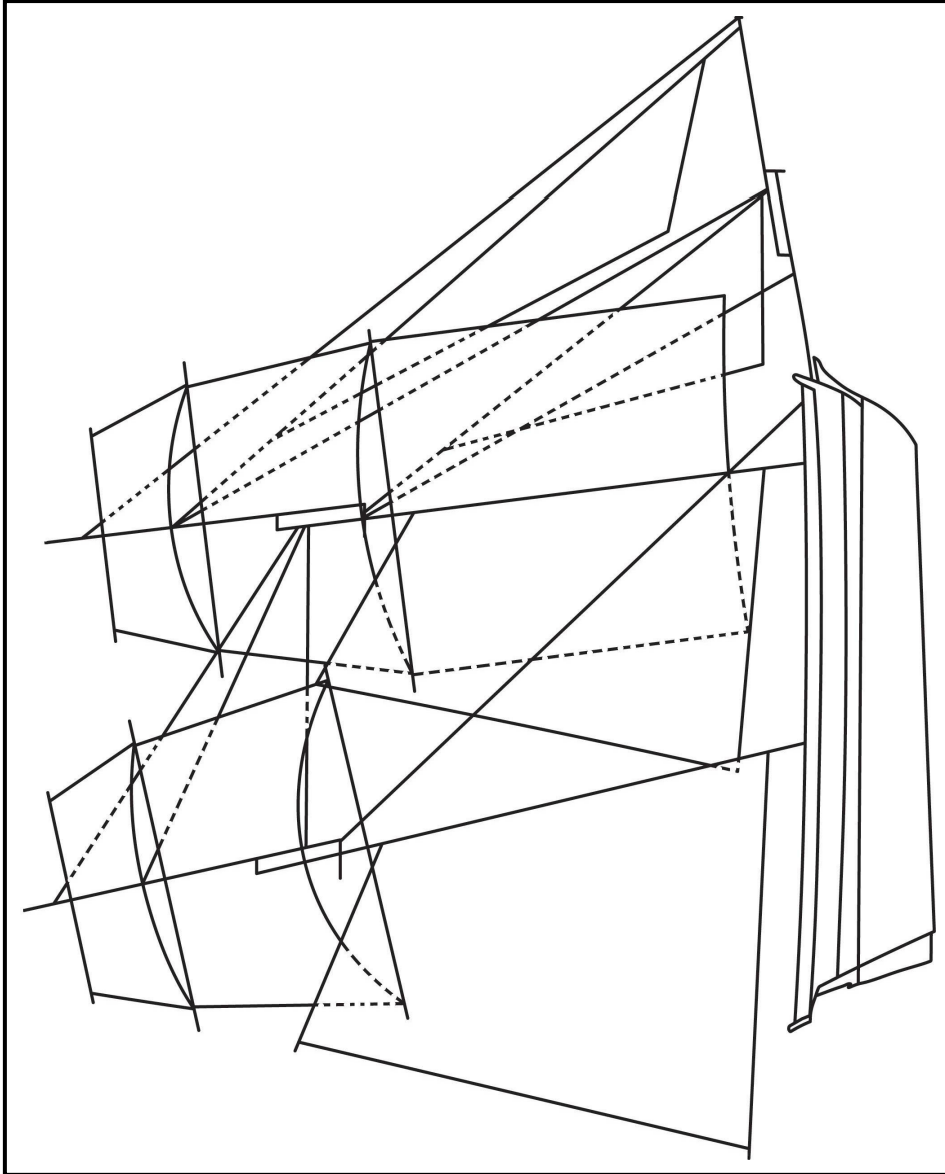

Figure 53: Hypothetical sail plan of original rig.

Table 5: Hypothetical Sails and Sail Area

Sail	Area
Mainsail	1918.75 square feet (178.32 m ²)
Main Topsail	677 square feet (62.92 m ²)
Main Topgallant	275 square feet (25.56 m ²)
Gaff Foresail	1225 square feet (113.85 m ²)
Fore Topsail	715 square feet (66.45 m ²)
Fore Topgallant	300 square feet (27.88 m ²)
Square Sail	1344 square feet (124.91 m ²)
Standing Jib	379.75 square feet (35.29 m ²)
Flying Jib	414 square feet (38.48 m ²)
Total	7248.5 square feet (677.00 m ²)

This amount of sail area is larger than what might be expected. Howard I. Chapelle calculated a predicted amount of sail area as 3.6 times that of the “load waterline section.”³⁸¹ Assuming that this means the waterplane area, rather than the area of the midships section below the waterline, this calculation yielded a predicted sail area of 4027.21 square feet (374.28 m²). The sail area, as calculated from the hypothetical sail plan, is more than 1.5 times that predicted.

From the hypothetical sail plan, several numbers were calculated. The first was the base of sail, which was measured from the tack of the flying jib to the clue of the mainsail. Chapelle noticed an overall relationship between the base of sail and the load waterline; the base of sail was between 1.6 and 1.7 times as long as the load waterline or line of flotation. Using this formula, a base of sail of was expected between 106.4 feet (32.44 m) and 113.05 feet (34.47 m). Measured from the prepared sail plan, however, the actual base of sail was 125.5 feet (38.26 m).

The midpoint of the base of sail is the same as the fore-and-aft position of the center of effort for the sail plan. To arrive at the height of the center of effort, Chapelle multiplied the extreme breadth of a vessel by a factor of 1.12. With this formula, the center of effort of the given sail plan was calculated as 27.44 feet (8.37 m) above the base of sail. This placed the center of effort in the middle of the foresail.

The center of effort was 42 feet (12.80 m) above the load waterline, and 13 feet (3.96 m) forward of the center of the lateral area of the underbody. The latter point was found by cutting the submerged hull from the sheer profile in the lines drawing and balancing it on the edge of a knife blade. The point about which such a profile balances was found just forward of the mainmast step (fig. 54). Chapelle pointed out that the middle of the base of sail (and, correspondingly, the center of effort of the sails) is often forward of the center of the lateral area of the underbody. In brigs and schooners, the distance between the two points is usually between .05 and .063 of the base of sail. These two factors yielded an expected distance of 6.28 feet (1.91 m) to 7.91 feet (2.41 m).

The distance between the center of the lateral area of the underbody and the midpoint of the base of sail can also be called the “leading.” High leading gave ships a certain amount of lee-helm, meaning that the ships had a greater tendency to fall off from the wind than to round up into it.

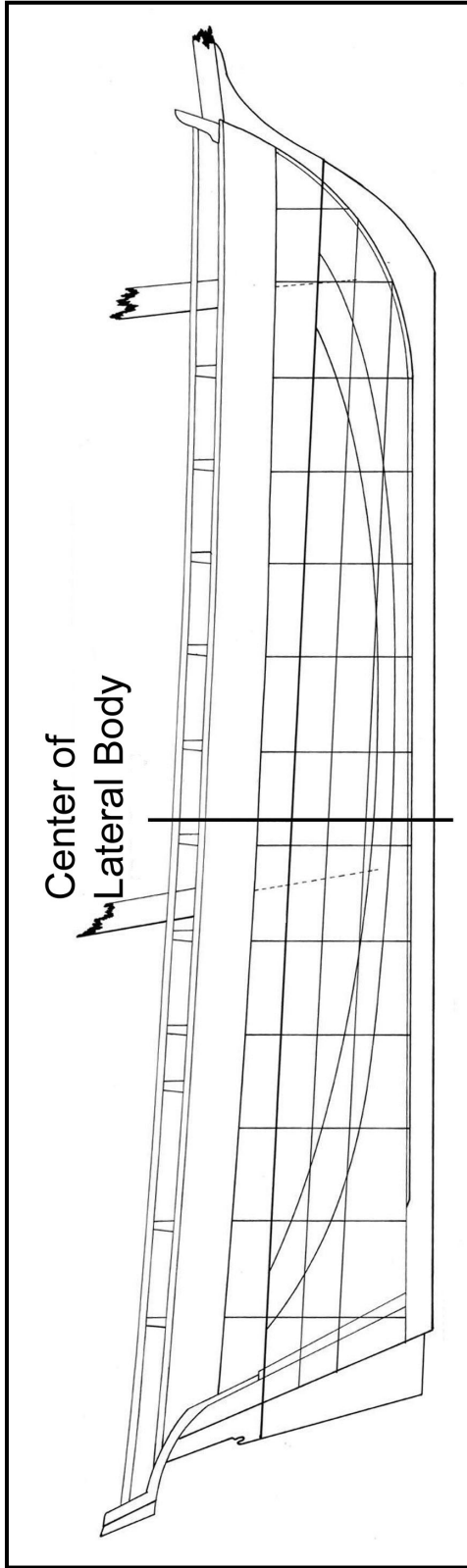

Figure 54: Center of lateral body.

Mast Placement

It should be remembered that the sail plan discussed here, while plausible, is hypothetical. Nevertheless, it is evident from the calculations and numbers that *Newash* and *Tecumseth* were two very unique vessels. For those with experience examining sailing craft, this should be evident upon first glancing at Robert Moore's draft of the ships. The foremast placement alone was unusual.

John Fincham gave specific proportions for the placement and rake of masts in schooners and brigantines. They are all based on the midpoint of the load waterline. Based on these examples, Chapelle devised a range of values for mast placement. The mainmast was placed abaft the midpoint by 0.05 – 0.11 of the load waterline length, and the foremast placed forward by 0.28 – 0.34.³⁸² These ranges were plotted on a copy of the vessels' draft (fig. 55). The mainmast falls almost directly in the center of the prescribed range, but the foremast is completely out of the predicted range. The foremast step is very far forward, placed atop the stem. The mast placement, particularly the far-forward foremast, gave the vessels their unique appearance, at least on paper.

There are no records to indicate why Robert Moore chose to place the foremasts so far forward in these vessels. It is possible that the mast placement was a result of the chosen rigging plan. When a vessel has two or more square-rigged masts, it is necessary to space them a good distance apart.

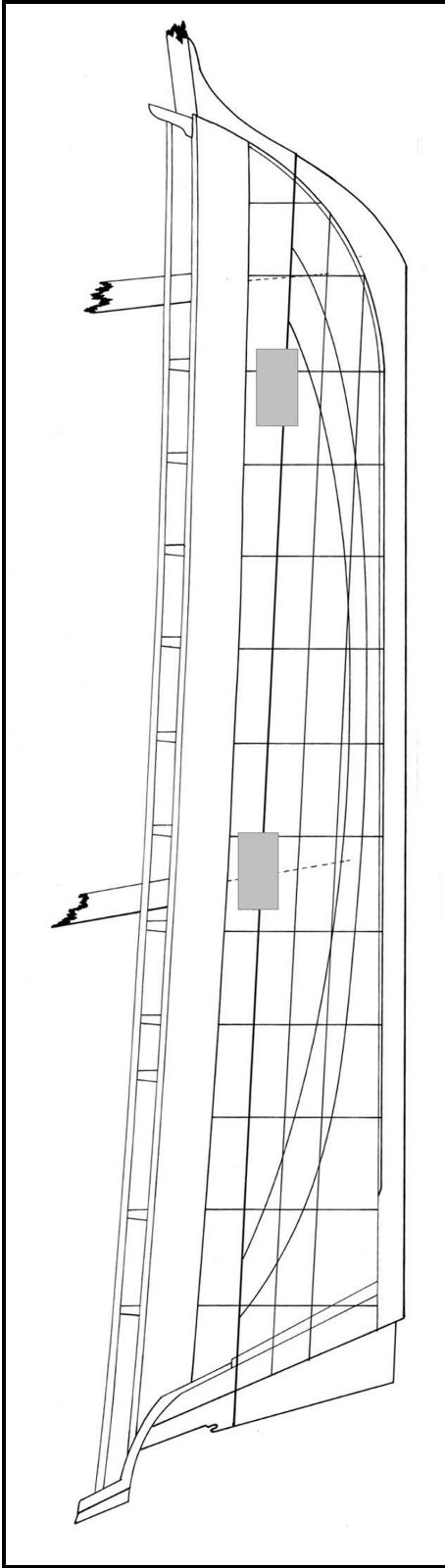

Figure 55: Draft showing predicted fore and main mast placement, in gray.

On most points of sail, square sails are braced into the wind, at least to some degree. When braced into the wind, air flows on both sides of a square sail and the sail itself forms an airfoil shape. The airfoil shape provides lift and drive that propels a ship. When two square-rigged masts are placed close together, the air flowing off the leeward side of a sail – the side furthest from the wind – on the forward mast can distort sails on the after mast. The after mast actually receives a breeze, on the wrong side of the sails, from the mast in front of it. This causes a distortion on the leeward side of the after sails, reducing their effectiveness.

Another issue that occurred with multiple masts and sails was blanketing. This was the effect of two sails whose areas overlapped, causing one sail to essentially steal wind from the other. Perhaps the best example of this effect was of a square-rigged vessel with the wind dead astern. No matter how the fore sails were braced, those on the main mast almost always blanketed them.

An ideal sail plan would have consisted of a solid “wall” of canvas, which used all the wind within its limits. Such a sail plan would have required a single, massive sail supported by tremendous timbers, which is unrealistic. Instead, shipwrights and naval architects created ways to use multiple smaller sails to achieve the same effect, while remaining manageable for those operating them. What is effective on one point of sail, however, is not always optimal for others. Thus, blanketing can occur, causing some sails to be distorted or even aback, with the wind entirely on the wrong side, while others

are drawing well. These concerns may have caused Moore to ensure that the masts were placed a good distance apart, which led to the placement shown in his draft.

It should be noted that the location of the foremast did yield a fairly balanced sail plan. The center of effort is a mathematical calculation based on the waterline and beam of a vessel, rather than the actual areas of the sails. Using that point as a midpoint, the sail areas forward and aft were calculated. The resultant areas were 3615.5 square feet (336.01 m^2) aft and 3633 square feet (337.64 m^2) forward. Had the foremast been placed any further aft, that much more sail area of the foresail would have been aft of the center of effort, potentially affecting how the vessels handled.

CHAPTER XIV

RECONSTRUCTION OF THE BRIGANTINE AND SCHOONER II RIGS

Mast placement was also an issue in reconstructing *Newash*'s second rigging arrangement, as a brigantine. The rigging change occurred at the end of the 1815 sailing season, while the vessels were laid up for the winter at Grand River. An account of work taking place at Grand River during December 1815 includes mention of "cutting new mast hole" and "shifting three streaks [strakes] of deck [planking] in wake of mast hole."³⁸³

Since only minimal changes were made to *Tecumseth*'s rig, it has been assumed that the new mast hole was cut in the deck of *Newash*, as part of the shift to a brigantine rig. The new foremast placement would have changed the geometry of the standing rigging. New headsails were cut to fit the new arrangement and the old standing and flying jibs were given to *Tecumseth*.³⁸⁴ The fore-and-aft rigged foresail could be of little use in the new rig, and was probably turned over to the other vessel as well.

When the raised hull was identified as *Tecumseth*, one of the points of evidence was the lack of a second foremast step. Surviving bolts and wedges indicated a mast step, the placement of which corresponded closely to the schooners' draft. Historian C.H.J. Snider proposed that the foremast was "probably moved aft 10 feet [3.05 m] and extended"³⁸⁵ when *Newash* was rigged as a brigantine.

A shift of 10 feet (3.05 m) seems a bit excessive. John Fincham's treatise on rigging noted that for brigantines, the foremast was placed before the middle of the waterline by 0.300 for one example and 0.294 for a second example.³⁸⁶ Both examples fall within Chapelle's prescribed range for a schooner's foremast placement, but require a shift of only 5 feet 9 inches (1.75 m) or 6 feet (1.83 m) aft.

Extending either of the masts also seems excessive. True, brigantine rigs were typically taller than schooner rigs. Fincham's overall mast heights for a schooner of 24-foot (7.32 m) beam are 92.60 feet (28.23 m) on the mainmast and 87.6 feet (26.71 m) on the fore. In comparison, using the same beam, a brigantine might be 112.30 feet (34.24 m) tall at the mainmast and 112 feet (34.15 m) tall at the fore.³⁸⁷ It is important to note that in both examples the mainmast is taller than the foremast; this is essential in rigging either a schooner or a brigantine.

It is unlikely that the existing sails, spars and rigging were all scrapped in favor of completely overhauling the rig. The account of work also mentioned "felling trees for foremast[,] fore topmast[,] fore topgallant mast[,] fore yard [and] fore topsail yard."³⁸⁸ It does not appear that the mainmast was altered, except to rig a gaff topsail instead of a square topsail and topgallant. Without extending the mainmast assembly, a longer foremast assembly is unlikely. It seems more befitting the Royal Navy to conserve resources where possible, reusing sails and spars and changing only what was absolutely

necessary. This was probably especially true on Lakes Erie and Huron, with their distances from resources and supplies, and secondary importance in the post-war years.

As might be expected, Fincham's schooners typically had longer gaffs and booms than Fincham's brigantines, but shorter yards. It is likely that the new yards cut and shaped for *Newash's* brigantine rig were slightly longer than those she had used as a schooner. The fore yard for a 70 foot-6 inch (21.49 m) common schooner, according to Fincham's treatise, was 40.30 feet (12.29 m); the fore topsail yard was 28.80 feet (8.78 m); the fore topgallant was 18.50 feet (5.64 m).³⁸⁹ In comparison, for a brigantine of the same length, the fore yard was 40.54 feet (12.36 m); the fore topsail yard was 29.83 feet (9.09 m); the fore topgallant yard was 17.11 feet (5.22 m).³⁹⁰

In addition to longer spars, which would have provided for larger sails, a fore topmast studdingsail could be set (fig. 56). The foot of the studdingsail was stretched by a small boom, which was stored atop the foreyard and could be pushed outboard for use. The bottom corners of the sail were tensioned and secured with a tack and a sheet, which led to the deck. The head of the sail was attached to a short yard that was hoisted from the deck by a studdingsail halyard.³⁹¹

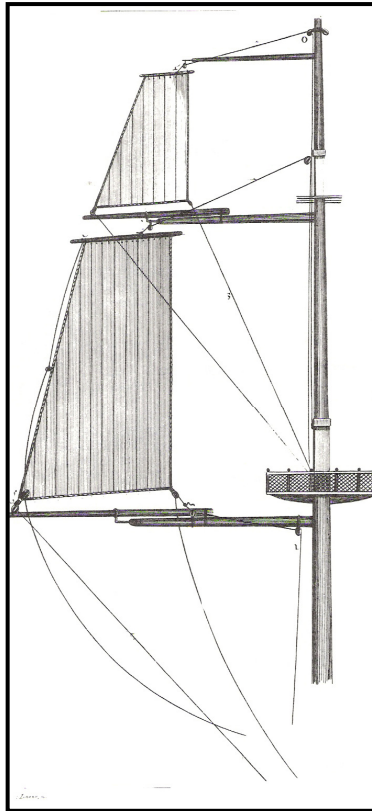

Figure 56: Studdingsails.
(Detail from Darcy Lever,
*The Young Sea Officer's
Sheet Anchor*, 65,
fig. 351.)

The Conversion Factor

Historian and artist Rowley Murphy, writing on the recovery of *Tecumseth* in 1954, proposed that the conversion of *Newash* from a schooner to a brigantine rig would have been accompanied by a change in standing rigging. Murphy noted that “[t]he usual practice in rigging vessels of brigantine or barkentine rig was, and is, to stay their foremasts with more shrouds than were used on the mainmast.”³⁹² Murphy theorized that “at least four and possibly five shrouds” were needed to stabilize a brigantine’s foremast.³⁹³ Murphy may be correct, and there was a blacksmith employed at the Grand River establishment who could have made the necessary ironwork for an additional chainplate or two. Bushby also requested 30 fathoms (180 feet or 54.88 m) of 4.50-inch (11.43 cm) rope, only slightly smaller than the 5-inch (12.70 cm) rope used for the fore shrouds.³⁹⁴ The account of work at the establishment, however, lists the smith “repairing stoves and stove pipes...making bolts for bolting steps of fore mast and tressle [sic] trees...[and] making hoops[,] staples and hooks to yard.”³⁹⁵ No mention was made of chainplates, chains, or deadeyes. The remains of what appear to be chainplates were found during Erich Heinold’s 1998 investigations on the wreck of *Newash*. Only three such pieces were found, though the associated timber remains are fragmentary.

It should be remembered that *Newash* was converted to a brigantine, rather than constructed as one. Some changes were certainly made, but probably not as many as if the hull had been completely stripped down and an entirely new rig designed. It is difficult, if not impossible, to determine exactly which items were retained and which

were altered. As schooners, *Newash* and *Tecumseth* were capable of carrying three square-rigged sails on their foremasts. On 11 October 1815, *Newash*'s logbook recorded sailing with "all sail," including square sail, fore topsail and fore topgallant.³⁹⁶ The foresail was set as well, giving the schooner a significant amount of canvas on her foremast. Even with longer yards and larger sails, it seems doubtful that the brigantine fore stack had more sail area than the schooner fore stack. Without an increase in sail area, it is questionable whether the vessel would have required additional standing rigging.

Gaff Topsails and Main Topmast Staysails

The extant mainmast assembly could be altered to accommodate a gaff topsail quite easily. British ships at this time commonly used lug-rigged gaff topsails, the sail being suspended between the main gaff at the foot, and a short spar called a lug at the head.³⁹⁷ Bushby's rigging warrant lists a gaff topsail halyard, sheet and downhaul. One 8-inch (20.33 cm) single sheave block was used for the halyard, with two 8-inch (20.33 cm) single sheave blocks for the sheet and a 6-inch (15.24 cm) single sheave block for the downhaul. This arrangement indicates that the sail was set flying. The halyard ran through the halyard block, which was affixed near the truck of the topgallant pole. The lug of the sail was bent on to the halyard before the sail could be set. One of the sheet blocks was placed at the peak of the main gaff, with the other acting as a turning block near the throat. The downhaul was probably tied to the clue of the sail, like the sheet, and ran through a block along the lug. When the sail was taken in, the sheet was cast off

and the downhaul hauled upon, which acted to brail the sail in, similar to the schooner foresail. The downhaul continued to be hauled on as the halyard was eased, bringing the sail and lug down to the deck. This assembly was probably used for both vessels, as gaff topsails were added to both the brigantine and revamped schooner rigs.

Tecumseth's second schooner rig varied only slightly from the original arrangement. A trysail mast was stepped on deck immediately abaft the foremast. The jaws of the fore gaff and boom fit around the trysail mast, while the squaresail yard was attached to the foremast itself. This allowed the sails to be operated more independently of each other. The square-rigged main topsail and main topgallant were removed, as with *Newash*, in favor of a main gaff topsail and a main topmast staysail.

E.W.C.R. Owen seems to have been enamored with the gaff topsail and main topmast staysail configuration. The arrangement was specifically chosen for *Sauk* and *Huron* when those schooners were refitted for the Royal Navy.³⁹⁸ In October 1815, E.W.C.R. Owen wrote of his “desire that in all the future equipments of these and other schooners on the Lakes, square main topsails shall not be issued, but that gaff main topsails and main topmast staysails shall be given them in lieu.”³⁹⁹

CHAPTER XV

CONCLUSIONS AND COMMENT

An individual vessel offers a unique insight into not only her specific purpose but potentially even to the political climate at the time of her inception. *Newash* and *Tecumseth* are particularly interesting, because of the light they shed on a very particular and little-known period of time. The Napoleonic Wars and the War of 1812 demanded certain ships, and the resultant vessels are fairly well documented. In almost every case, the possibility or certainty of war is evident. These were gun ships and row galleys, ships that were off the stocks in mere weeks, and were often fragile platforms laden with enormous artillery. War was the principle of the time. When war was removed, however, the paradigms that dictated thinking and building had to shift. Perhaps the most interesting aspect of the two schooners discussed here is their presentation of how that shift occurred.

Unlike the prevalent attitude of the shipbuilders' war on the Great Lakes, the size of *Tecumseth* and *Newash* indicates that bigger was no longer thought to be better. E.W.C.R. Owen specified two schooners of 130 tons were to be built. Robert Moore designed them to be a little larger, a little sleeker, and a little faster. Even while designed as sharp hulls, their primary purpose of transporting troops and stores was evident. *Newash* and *Tecumseth* were beamier than their War of 1812 counterparts. Their shallow, wide hulls would have made the vessels dangerous and unsafe on ocean passages, but Lakes Erie and Huron offered a different scenario entirely.

The original configuration of the ships had them equipped with four guns apiece and lofty rigs. Square sails were placed on both masts. Large crews allowed the schooners to set heavy sails with manpower alone. Yet even in their short sailing careers, both vessels' rigs were altered. The new rigs were originally implemented as experiments. With the war over, concepts of sails and sailing that had been germinating could be put to a test. The most prominent change in these two new rigs was the abandonment of square sails on the mainmast in favor of fore-and-aft rigged gaff topsail and main topmast staysail.

The shift in sails is striking. Why bother to change half of the rig after only half of a sailing season? One reason may be the changing political atmosphere on the Great Lakes. The hard-fought War of 1812 was over. Little territory had changed hands, and that had changed right back. Hard feelings remained, but neither side was eager to reenter the bloody stages of battle again. Except for occasional spikes of enmity, tensions cooled after the Treaty of Ghent.

When *Newash* and *Tecumseth* were first envisioned, peace was a novelty. Though officially transports, the schooners were to be heavily armed and ready to fight at a moments' notice. In case fighting erupted, the schooners were rigged with square sails on the fore and main masts.

Square sails were a feature of vessels sailing downwind, such as trade-wind sailing vessels, and ships at war. The balance of square sails, particularly when placed on more than one mast, allows a ship to slow down, stop herself, drift sideways or go backwards. When engaging an enemy, they can maneuver quickly and in tight quarters. Fore-and-aft sails are useful on more points of sail, but vessels carrying them are slower to react, and slower to turn. Fore-and-aft vessels are best used in evading an enemy, running a blockade, outpointing another ship or sailing fast.

Had post-war strain and stress flared anywhere on Lake Huron or Lake Erie, *Newash* and *Tecumseth* could have sailed there quickly, and acted as battleships when needed.

During their first season, however, it became increasingly apparent that while tensions still existed, diplomacy rather than deadly force would be used. *Newash* and *Tecumseth*'s square sails became antiquated. The vessels were re-rigged with a more "peaceful" sail plan.

Elsewhere on the lakes, the shifting politics became evident as well. British military outposts were reduced in size and number. A number of men were given acreage in Canada, populating the frontier with loyal settlers and offering a base from which to draft recruits should the need arise. Fewer men were required on the establishments, and on the ships as well.

With fewer men working the same rig, each man would need to do a little more work. Adapting *Tecumseth* and *Newash*'s rigs for a smaller crew would have been a matter of simply exchanging a few single sheave blocks for double sheave blocks and increasing the purchase power of the tackles. Without a square-rigged main topsail, there was no yard aloft to be raised, or brought down in case of poor weather. The gaff topsail was set from the deck, as was the fore topgallant. The sails had a number of reef bands, allowing them to be shortened in case of inclement weather. The regular company was often augmented by men being transported, who could be counted on to haul on a line if needed.

The Rush-Bagot agreement rendered *Newash* and *Tecumseth* obsolete after very short sailing careers. Ironically, interactions with American ships occurring onboard the ships themselves affected the way the agreement was framed. The vessels had acted as architects of their own demises. William Bouchier had thought his post on Lake Erie a distant and obscure corner of Canada; the harbor where the schooners were retired truly was. Disarmed and neglected as peace prevailed, the ships simply rotted away.

The rebirth of interest in Great Lakes naval history that led to the relocation and removal of *Tecumseth* in 1953 ignored the shadowy story of post-war people and politics. The people of Penetanguishene wanted to recover a warship, preferably a relic from the Battle of Lake Erie. The skeletal remains failed to live up to pre-salvage enthusiasm.

In recent years, however, with the introduction of nautical archaeology and the incorporation of various disciplines that it demands, the story of *Tecumseth* and *Newash* has come to light. The two vessels are really fascinating and their history, while short, is intriguing; analysis of the architecture and rigging shows that they were remarkable vessels in many ways. The two hulls have offered a truly unique point from which to gather information on the variety of areas that influence different aspects of a singular vessel design.

NOTES

- 1 For full text of the treaty, see Appendix A.
- 2 L. Farrington, "The Decline of Naval Bases on the Lakes of Canada," 3.
- 3 James Lucas Yeo to Prevost, 25 February 1815. LAC, Admiralty Fonds, ADM 1/2262.
- 4 Bathurst to Drummond, 10 January 1815, in William Wood, *Select British Documents of the Canadian War of 1812*, vol. III, part I, 507.
- 5 There are two Owen brothers – Commodore Edward William Campbell Rich Owen and Captain William Fitz William Owen – who factor significantly into this story. To avoid confusion, their initials and last name – E.W.C.R. Owen and W.F.W. Owen – will be used throughout the text to distinguish between them.
- 6 The title "Senior Officer on the Lakes of Canada" was used in most correspondence addressed to E.W.C.R. Owen, though he signed his letters "Commodore in Command." See LAC, Admiralty Fonds, ADM 1/2262-2266.
- 7 E.W.C.R. Owen, "Estimate of the Force Required for the War Establishment on the Lakes of Canada," 5 November 1815. LAC, Admiralty Fonds, ADM 1/2264. Since the Royal Navy apparently had no intention of carrying out these plans, Owen's estimate can only be considered hypothetical.
- 8 *A Naval Encyclopaedia*, 1881, s.v. "Ordnance."
- 9 E.W.C.R. Owen to Dobbs, 17 July 1815. LAC, Record Group 8, Series III, Vol. 3.
- 10 Lieutenant Colonel Robert McDouall was to recommend a site for the new military post, but the site had to be approved by a naval officer before construction could begin. J. Harvey to E.W.C.R. Owen, 27 March 1815. LAC, Admiralty Fonds, ADM 1/2262.
- 11 While Lakes Erie, Huron and Michigan are all geographically connected, the Royal Navy had little interest or need to venture into Lake Michigan, and most of its efforts were confined to the other bodies of water.
- 12 E.W.C.R. Owen to Croker, 28 November 1816. LAC, Admiralty Fonds, ADM 1/2264.
- 13 The Lachine locks opened in 1825, the Welland Canal (between Lakes Erie and Ontario) in 1829 and the Rideau Canal in 1832.
- 14 Robert Hall to Navy Board, 29 November 1814. LAC, Admiralty Fonds, ADM 106/1997.
- 15 James Lucas Yeo to Prevost, 25 February 1815. LAC, Admiralty Fonds, ADM 1/2262.
- 16 E.W.C.R. Owen to Croker, 25 March 1815. LAC, Admiralty Fonds, ADM 1/2262.
- 17 Robert McDouall to Forster, 15 March 1815, in William Wood, *Select British Documents of the Canadian War of 1812*, vol. III, part I, 532.
- 18 Robinson to Prevost, 14 November 1814, in William Wood, *Select British Documents of the Canadian War of 1812*, vol. III, part I, 503.

- 19 Edward Collier to Yeo, 11 March 1815. LAC, Admiralty Fonds, ADM 1/2262.
- 20 E.W.C.R. Owen to Drummond, 6 April 1815, PRO, Record Group 8, Series IC, vol. 734.
- 21 Draft of Schooners. PRO, Admiralty Fonds, ADM, Reg. No. 4562, Box 64.
- 22 Henry Kent to E.W.C.R. Owen, 11 June 1815. LAC, Admiralty Fonds, ADM 1/2262.
- 23 Robert Hall to Navy Board, 18 May 1815. LAC, Admiralty Fonds, ADM 106/1997.
- 24 Henry Kent to E.W.C.R. Owen, 11 June 1815. LAC, Admiralty Fonds, ADM 1/2262. A work party of 24 Royal Marines at Street's Creek was employed rafting timber from the Chippewa to the shipyard.
- 25 E.W.C.R. Owen, "Observations relative to the defence [sic] of the Lake Frontier continued from enclosures to Letters 36, 37 and 48," 5 November 1815. LAC, Admiralty Fonds, ADM 1/2264.
- 26 E.W.C.R. Owen, "Observations relative to the defence [sic] of the Lake Frontier continued from enclosures to Letters 36, 37 and 48," 5 November 1815. LAC, Admiralty Fonds, ADM 1/2264.
- 27 In spite of the fact that only *Huron* and *Sauk* were actually outfitted on the banks of the Chippewa River, Chippewa (also spelled "Chippawa" and "Chippeway") is given as the site of the construction of *Newash* and *Tecumseth* in several Admiralty documents. Robert Hall to Navy Board, 18 May 1815. LAC, Admiralty Fonds, ADM 106/1997.
- 28 E.W.C.R. Owen to Croker, 19 April 1815. LAC, Admiralty Fonds, ADM 1/2262.
- 29 E.W.C.R. Owen to Croker, 19 April 1815. LAC, Admiralty Fonds, ADM 1/2262.
- 30 Robert Hall to Navy Board, 18 May 1815. LAC, Admiralty Fonds, ADM 106/1997.
- 31 Draft of Schooners. PRO, Admiralty Fonds, ADM, Reg. No. 4562, Box 64.
- 32 "Statement of Force on Lake Erie and Huron [sic]," 1 June 1815. LAC, Admiralty Fonds, ADM 1/2262.
- 33 E.W.C.R. Owen to Drummond, 6 April 1815. PRO, Record Group 8, Series IC, vol. 734.
- 34 For a discussion of what it means to be a "sharp" vessel and the hull characteristics of these ships, see Chapter 11.
- 35 Draft of Schooners. PRO, Admiralty Fonds, ADM, Reg. No. 4562, Box 64.
- 36 Draft of Schooners. PRO, Admiralty Fonds, ADM, Reg. No. 4562, Box 64.
- 37 The spelling "fo'c'sle" is also commonly used.
- 38 "Statement of Force on Lake Erie and Huron [sic]," 1 June 1815. LAC, Admiralty Fonds, ADM 1/2262.
- 39 "Statement of Force on Lake Erie and Huron [sic]," 1 June 1815. LAC, Admiralty Fonds, ADM 1/2262.

40 Robert Hall to Navy Board, 18 May 1815. LAC, Admiralty Fonds, ADM 106/1997.

41 This change may have been made because it allowed the ships to carry one size shot, which could be used in any of the guns. There was one gunner at the Lake Erie establishment, but he could not be present on each of the vessels in the fleet. Had any of the schooners actually seen combat action, it would have been easier to carry one size shot that could be used universally.

42 For an excellent history of the carronade, see Spencer C. Tucker, "The Carronade," 65 – 70.

43 E.W.C.R. Owen to Drummond, 4 April 1815. PRO, Record Group 8, Series IC, vol. 734.

44 Robert Hall to Navy Board, 18 May 1815. LAC, Admiralty Fonds, ADM 106/1997.

45 E.W.C.R. Owen, "General Instructions for the Commander of the Naval Establishment upon Lake Erie," 12 October 1815. LAC, Admiralty Fonds, ADM 1/2264.

46 E.W.C.R. Owen, "General Instructions for the Commander of the Naval Establishment upon Lake Erie," 12 October 1815. LAC, Admiralty Fonds, ADM 1/2264.

47 E.W.C.R. Owen to the Captain Commanding the Naval Establishment at Isle Aux Noix, 15 June 1815. LAC, Admiralty Fonds, ADM 106/1997.

48 Officer's Service Record, Captain Thomas Bushby. PRO, Admiralty Fonds, ADM 196/3.

49 Officer's Service Record, Captain Henry Kent. PRO, Admiralty Fonds, ADM 196/5, part 1.

50 H.F. Pullen, *March of the Seamen*, 16.

51 H.F. Pullen, *March of the Seamen*, 17.

52 Edwards Laws to Walker, 4 July 1815. LAC, Record Group 8, Series III, vol. 5.

53 "A General Table of Day Pay, for the Workmen in His Majesty's Dock and Rope Yards, Established by Admiralty Order," 19 March 1815. LAC, Record Group 8, Series III, vol. 1.

54 E.W.C.R. Owen, "Observations relative to the defence [sic] of the Lake Frontier continued from enclosures to Letters 36, 37 and 48," 5 November 1815. LAC, Admiralty Fonds, ADM 1/2264.

55 "Log of the Proceedings on Board HM Schooner/Brigantine *Newash* on Lake Erie, 13 August 1815 – 30 June 1817," 13 August 1815. PRO, Admiralty Fonds, ADM 51/2607.

56 "Log of the Proceedings on Board HM Schooner/Brigantine *Newash* on Lake Erie, 13 August 1815 – 30 June 1817," 14 August 1815. PRO, Admiralty Fonds, ADM 51/2607.

57 "Log of the Proceedings on Board HM Schooner/Brigantine *Newash* on Lake Erie, 13 August 1815 – 30 June 1817," 15 August 1815. PRO, Admiralty Fonds, ADM 51/2607.

58 Edward Laws to Navy Board, 13 September 1815. LAC, Admiralty Fonds, ADM 106/1997; Edward Laws to Payne, 12 September 1815. LAC, Admiralty Fonds, ADM 106/1997; Robert Hall to Navy Board, 26 November 1815. LAC, Admiralty Fonds, ADM 106/1997.

59 For a description of a schooner's rigging elements and sails, see Appendix B.

60 Thomas Bushby, "An Account of Rigging and Sails Belonging to His Majesty's Schooner *Newash*," 19 September 1815. LAC, Record Group 8, Series III, vol. 5.

61 In reality, it is redundant to say "forward-leading stays" since the nature of a stay is that it leads forward. To avoid any confusion between "stays" and "backstays" in this discussion, however, the terminology has been used.

62 A similar situation occurred on H.M.S. *Princess Charlotte* in 1814, which was heaved down over the course of three days to remove cleats which remained on her bottom after launching. Henry Kent, "The Extraordinary March of Lieutenant Henry Kent," 9.

63 "Log of the Proceedings on Board HM Schooner/Brigantine *Newash* on Lake Erie, 13 August 1815 – 30 June 1817," 21 August 1815. PRO, Admiralty Fonds, ADM 51/2607.

64 Thomas Bushby, "An Account of the Rigging and Sails Belonging to His Majesty's Schooner *Newash*," 19 September 1815. LAC, Record Group 8, Series III, vol. 5.

65 Charles Payne to Laws, 25 August 1815. LAC, Admiralty Fonds, Record Group 8, Series III, vol. 4, Number 2.

66 "Log of the Proceedings on Board HM Schooner/Brigantine *Newash* on Lake Erie, 13 August 1815 – 30 June 1817" 26 August 1815. PRO, Admiralty Fonds, ADM 51/2607.

67 Henry Kent, "Log of H.M. Brigantine *Newash* on the Lakes Erie and Huron Between the 14th of November 1816 and 30th June 1817," 14 November 1816. LAC, Admiralty Fonds, ADM 52/4548.

68 See James Childs, "Log of the Proceedings onboard H.M. Schooner *Tecumseth* on Lake Erie Between the 13th of August 1815 and 13th of November 1816," 30 August 1815, 31 August 1815, 1 September 1815. LAC, Admiralty Fonds, ADM 52/3933; "Log of the Proceedings on Board HM Schooner/Brigantine *Newash* on Lake Erie, 13 August 1815 – 30 June 1817," 30 August 1815, 31 August 1815. PRO, Admiralty Fonds, ADM 51/2607.

69 James Childs, "Log of the Proceedings onboard H.M. Schooner *Tecumseth* on Lake Erie Between the 13th of August 1815 and 13th of November 1816," 30 August 1815. LAC, Admiralty Fonds, ADM 52/3933.

70 Three logbooks record the events of the morning of 2 September 1815, but do not agree on the exact wind direction. Captain Bouchier recorded a northerly wind, Second Master Childs a north-northeasterly wind, and Lieutenant Bushby a south-southwesterly breeze. Bushby is the only one to record a sea direction, observing a southwesterly swell. This makes the south-southwesterly breeze which Bushby records seem more likely. It also seems more appropriate to the situation described, since a northerly or north-northeasterly wind would not have had the fetch, or long stretch of sea room, necessary to kick up the swell that occurred.

71 "Log of the Proceedings on Board HM Schooner/Brigantine *Newash* on Lake Erie, 13 August 1815 – 30 June 1817," 2 September 1815. PRO, Admiralty Fonds, ADM 51/2607.

72 William Bouchier, "Journal of the Proceedings of His Majesty's Ships Viz: *Tecumseth* From 12th August 1815 to 30th June 1817, *Laurel* from 21st February 1811 to 21st December 1814," 2 September 1815. LAC, Admiralty Fonds, ADM 51/2502.

73 The rank of “Second Master” seems to be much less common than “Master’s Mate,” though both titles refer to an individual subordinate to the vessel’s master, who carried out the more menial of the master’s tasks. In most cases, the “Second Master” or “Master’s Mate” was apprenticed to the Master, a useful step for those who would eventually pursue higher naval ranks. John Masefield, *Sea Life in Nelson’s Time*, 68.

74 James Childs, “Log of the Proceedings onboard H.M. Schooner *Tecumseth* on Lake Erie Between the 13th of August 1815 and 13th November 1816,” 2 September 1815. LAC, Admiralty Fonds, ADM 52/3933.

75 Gusts are here assumed to be one and half times greater than the sustained winds of these conditions. Using a mean wind speed at Force 5 of 19 knots (21.87 mph), gusts for the same conditions would reach 28.5 knots (32.79 mph).

76 “Log of the Proceedings on Board HM Schooner/Brigantine *Newash* on Lake Erie, 13 August 1815 – 30 June 1817,” 2 September 1815. PRO, Admiralty Fonds, ADM 51/2607.

77 “Log of the Proceedings on Board HM Schooner/Brigantine *Newash* on Lake Erie, 13 August 1815 – 30 June 1817,” 2 September 1815. PRO, Admiralty Fonds, ADM 51/2607.

78 “Log of the Proceedings on Board HM Schooner/Brigantine *Newash* on Lake Erie, 13 August 1815 – 30 June 1817,” 5 September 1815. PRO, Admiralty Fonds, ADM 51/2607.

79 E.W.C.R. Owen, “General Instructions for the Commander of the Naval Establishment upon Lake Erie,” 12 October 1815. LAC, Admiralty Fonds, ADM 1/2264.

80 E.W.C.R. Owen to Drummond, 10 July 1815. PRO, Record Group 8, Series IC, vol. 735.

81 James Childs, “Log of the Proceedings onboard H.M. Schooner *Tecumseth* on Lake Erie Between the 13th of August 1815 and 13th of November 1816,” 29 June 1816. LAC, Admiralty Fonds, ADM 52/3933.

82 James Childs, “Log of the Proceedings onboard H.M. Schooner *Tecumseth* on Lake Erie Between the 13th of August 1815 and 13th of November 1816,” 18 June 1816. LAC, Admiralty Fonds, ADM 52/3933.

83 James Childs, “Log of the Proceedings onboard H.M. Schooner *Tecumseth* on Lake Erie Between the 13th of August 1815 and 13th of November 1816,” 16 August 1816. LAC, Admiralty Fonds, ADM 52/3933.

84 Navy Office to the Respective Officers of His Majesty’s Yard at Quebec, 12 June 1815. LAC, Record Group 8, Series III, vol. 1.

85 James Childs, “Log of the Proceedings onboard H.M. Schooner *Tecumseth* on Lake Erie Between the 13th of August 1815 and 13th of November 1816,” 9 April 1816. LAC, Admiralty Fonds, ADM 52/3933.

86 James Childs, “Log of the Proceedings onboard H.M. Schooner *Tecumseth* on Lake Erie Between the 13th of August 1815 and 13th of November 1816,” 15 June 1816. LAC, Admiralty Fonds, ADM 52/3933.

87 James Childs, “Log of the Proceedings onboard H.M. Schooner *Tecumseth* on Lake Erie Between the 13th of August 1815 and 13th November 1816,” 23 December 1815. LAC, Admiralty Fonds, ADM 52/3933.

88 James Childs, “Log of the Proceedings onboard H.M. Schooner *Tecumseth* on Lake Erie Between the 13th of August 1815 and 13th of November 1816,” 13 June 1816. LAC, Admiralty Fonds, ADM 52/3933.

- 89 E.W.C.R. Owen to Laws, 5 October 1815. LAC, Record Group 8, Series III, vol. 5.
- 90 E.W.C.R. Owen to W.F.W. Owen, 18 November 1815. LAC, Admiralty Fonds, ADM 1/2264.
- 91 E.W.C.R. Owen to Croker, 2 December 1815. LAC, Admiralty Fonds, ADM 1/2264.
- 92 For examples of these specific provisions, see James Childs, "Log of the Proceedings onboard H.M. Schooner *Tecumseth* on Lake Erie Between the 13th of August 1815 and 13th of November 1816," 17 July 1816, 27 July 1816, 28 July 1816 and 26 October 1816. LAC, Admiralty Fonds, ADM 52/3933.
- 93 James Childs, "Log of the Proceedings onboard H.M. Schooner *Tecumseth* on Lake Erie Between the 13th of August 1815 and 13th of November 1816," 9 June 1816. LAC, Admiralty Fonds, ADM 52/3933.
- 94 W.F.W. Owen to Respective Captains and Commanders of His Majesty's Ships and Vessels on the Lake Ontario, no date. LAC, Admiralty Fonds, ADM 1/2265.
- 95 W.F.W. Owen to Baumgardt, no date. LAC, Admiralty Fonds, ADM 1/2265.
- 96 "Weekly Returns, 1st – 31st January 1816, Lake Huron." LAC, Admiralty Fonds, ADM 1/2265.
- 97 "Weekly Returns, 2nd October to 30 November 1815 on Lake Huron." LAC, Admiralty Fonds, ADM 1/2265; "Weekly Returns, 1st – 31st January 1816, Lake Huron." LAC, Admiralty Fonds, ADM 1/2265.
- 98 James Childs, "Log of the Proceedings onboard H.M. Schooner *Tecumseth* on Lake Erie Between the 13th of August 1815 and 13th of November 1816," 26 July 1816. LAC, Admiralty Fonds, ADM 52/3933.
- 99 James Childs, "Log of the Proceedings onboard H.M. Schooner *Tecumseth* on Lake Erie Between the 13th of August 1815 and 13th of November 1816," 3 April 1816. LAC, Admiralty Fonds, ADM 52/3933.
- 100 Thomas Bushby, "An Account of Rigging and Sails Belonging to His Majesty's Schooner *Newash*," 19 September 1815. LAC, Record Group 8, Series III, vol. 5.
- 101 Twenty-five feet (7.62 m) is 1/240 of a nautical mile (6000 ft or 1829.27 m). Correspondingly, 15 seconds is 1/240 of an hour (60 minutes or 3600 seconds).
- 102 If using a 15-second glass, the number of knots counted equals the ships speed in nautical miles per hour, or knots. If using a 30-second glass, the number of knots must be divided by two, or an additional log line must be prepared with knots 50 feet (15.24 m) apart. William Brady, writing on American naval practices in 1847, used a 28-second glass and a log line with marks every 47.60 feet (14.51 m). Brady seemed concerned with measuring the fractions of each knot (in eighths) but his method seems unnecessarily complex. William Brady, *The Kedge-Anchor or Young Sailor's Assistant*, 148.
- 103 Thomas Bushby, "An Account of Rigging and Sails Belonging to His Majesty's Schooner *Newash*," 19 September 1815. LAC, Record Group 8, Series III, vol. 5.
- 104 Thomas Bushby, "An Account of Rigging and Sails Belonging to His Majesty's Schooner *Newash*," 19 September 1815. LAC, Record Group 8, Series III, vol. 5.
- 105 James Childs, "Log of the Proceedings onboard H.M. Schooner *Tecumseth* on Lake Erie Between the 13th of August 1815 and 13th of November 1816," 8 October 1816. LAC, Admiralty Fonds, ADM 52/3933.

106 James Childs, "Log of the Proceedings onboard H.M. Schooner *Tecumseth* on Lake Erie Between the 13th of August 1815 and 13th of November 1816," 17 May 1816. LAC, Admiralty Fonds, ADM 52/3933.

107 James Childs, "Log of the Proceedings onboard H.M. Schooner *Tecumseth* on Lake Erie Between the 13th of August 1815 and 13th of November 1816," 29 October 1816. LAC, Admiralty Fonds, ADM 52/3933.

108 James Childs, "Log of the Proceedings onboard H.M. Schooner *Tecumseth* on Lake Erie Between the 13th of August 1815 and 13th of November 1816," 12 June 1816. LAC, Admiralty Fonds, ADM 52/3933.

109 James Childs, "Log of the Proceedings onboard H.M. Schooner *Tecumseth* on Lake Erie Between the 13th of August 1815 and 13th of November 1816," 28 April 1816. LAC, Admiralty Fonds, ADM 52/3933.

110 W.F.W. Owen to Bouchier, 20 May 1816. LAC, Admiralty Fonds, ADM 1/2266.

111 James Childs, "Log of the Proceedings onboard H.M. Schooner *Tecumseth* on Lake Erie Between the 13th of August 1815 and 13th of November 1816," 1 September 1816. LAC, Admiralty Fonds, ADM 52/3933.

112 Thomas Bushby, "An Account of Rigging and Sails Belonging to His Majesty's Schooner *Newash*," 19 September 1815. LAC, Record Group 8, Series III, vol. 5.

113 James Childs, "Log of the Proceedings onboard H.M. Schooner *Tecumseth* on Lake Erie Between the 13th of August 1815 and 13th of November 1816," 23 April 1816. LAC, Admiralty Fonds, ADM 52/3933.

114 It is regular practice on the U.S. Brig *Niagara*, a modern re-interpretation of a war of 1812 vessel, to haul the ship to short stay by hand, and employ the brig's capstan only when breaking the anchor out of the lake bottom. Captain Walter Rybka, master of *Niagara*, has stated that the momentum gathered by the hull as the anchor rode is hauled on often causes the ship to sail over her anchor, breaking it out in the process. In this case, the capstan is used only as a safety precaution. Walter Rybka, pers. comm.

115 "Log of the Proceedings on Board HM Schooner/Brigantine *Newash* on Lake Erie, 13 August 1815 – 30 June 1817," 27 September 1815. PRO, Admiralty Fonds, ADM 51/2607.

116 Thomas Bushby to Bouchier, 9 November 1815. PRO, Record Group 8, Series IC, vol. 736.

117 E.W.C.R. Owen to Baker, 23 October 1815. LAC, Admiralty Fonds, ADM 1/2264.

118 Enclosed in E.W.C.R. Owen to Baker, 23 October 1815. LAC, Admiralty Fonds, ADM 1/2264.

119 Thomas Jefferson to Crawford, 14 February 1815, with Postscript dated 26 February. "American Memory, The Thomas Jefferson Papers."

120 James Jackson to Bouchier, 16 November 1815. LAC, Admiralty Fonds, ADM 1/2265.

121 Laws to Navy Board, 18 May 1816. LAC, Admiralty Fonds, ADM 106/1997.

122 E.W.C.R. Owen to Baker, 9 September 1815. LAC, Admiralty Fonds, ADM 1/2263.

123 E.W.C.R. Owen to Baker, 9 September 1815. LAC, Admiralty Fonds, ADM 1/2263.

124 Alexander Vidal to E.W.C.R. Owen, 8 November 1815. LAC, Admiralty Fonds, ADM 1/2265.

125 Alexander Vidal to E.W.C.R. Owen, 16 October 1815, Enclosed in E.W.C.R. Owen to Baker, 6 November 1815. LAC, Admiralty Fonds, ADM 1/2265.

126 Sir Anthony Baker had been one of the commissioners to ratify the Treaty of Ghent.

127 Alexander Vidal to E.W.C.R. Owen, 16 October 1815, Enclosed in E.W.C.R. Owen to Baker, 6 November 1815. LAC, Admiralty Fonds, ADM 1/2265. Including the attorney's fee, Vidal was required to pay \$778.85.

128 E.W.C.R. Owen to Baker, 6 November 1815. LAC, Admiralty Fonds, ADM 1/2265.

129 E.W.C.R. Owen to Baker, 6 November 1815. LAC, Admiralty Fonds, ADM 1/2265.

130 E.W.C.R. Owen to Baker, 6 November 1815. LAC, Admiralty Fonds, ADM 1/2265.

131 Richard Rush to Bagot, 4 April 1817. LAC, Bagot Papers, Military Group 24, Series A13, vol. 14. The situation was still unsettled in April 1817.

132 See W.F.W. Owen to Hambly, 16 December 1815; Sir Gordon Drummond to W.F.W. Owen, 6 January 1816; W.F.W. Owen to Sir Gordon Drummond, 17 January 1816a and 17 January 1816b. LAC, Admiralty Fonds, ADM 1/2265.

133 W.F.W. Owen to Drummond, 17 January 1816a. LAC, Admiralty Fonds, ADM 1/2265.

134 E.W.C.R. Owen, "Observations relative to the defence [sic] of the Lake Frontier continued from enclosures to Letters 36, 37 and 48," 5 November 1815. LAC, Admiralty Fonds, ADM 1/2264.

135 E.W.C.R. Owen, "Observations relative to the defence [sic] of the Lake Frontier continued from enclosures to Letters 36, 37 and 48," 5 November 1815. LAC, Admiralty Fonds, ADM 1/2264.

136 W.F.W. Owen to Drummond, 17 January 1816b. LAC, Admiralty Fonds, ADM 1/2265.

137 Robert Hall to Navy Board, 12 March 1815. LAC, Admiralty Fonds, ADM 106/1997.

138 John Aldersly to W.F.W. Owen, Enclosed in Thomas Payne to Croker, no date. LAC, Admiralty Fonds, ADM 1/2263.

139 E.W.C.R. Owen to Croker, 8 October 1815. LAC, Admiralty Fonds, ADM 1/2263.

140 Burlington Bay is on the western shore of Lake Ontario, near the modern city of Hamilton, Ontario. W.F.W. Owen to E.W.C.R. Owen, 20 July 1815. LAC, Admiralty Fonds, ADM 1/2263.

141 W.F.W. Owen to E.W.C.R. Owen, 20 July 1815. LAC, Admiralty Fonds, ADM 1/2263.

142 United States Army Corps of Engineers, "Detroit District – Detroit River." This phenomena is not limited to the Grand River entrance. The whole of Lake Erie is affected by certain winds. In modern times, the U.S. Army Corps of Engineers has recorded a surface difference of 14.50 feet (4.42 m) from one end of the lake to the other. Several of the smaller adjacent waterways are likewise affected, such as Sandusky Bay and the Detroit River.

143 John Harris and John Aldersly to E.W.C.R. Owen, 10 June 1815. PRO, Record Group 8, Series IC, vol. 370.

144 E.W.C.R. Owen to Laws, 5 August 1815. LAC, Record Group 8, Series III, vol. 5. These barracks were apparently not complete when the vessels arrived, as a working party from *Tecumseth*'s crew was sent "building Barracks" after the vessel arrived at Grand River. James Childs, "Log of the Proceedings onboard H.M. Schooner *Tecumseth* on Lake Erie Between the 13th of August 1815 and the 13th November 1816," 15 November 1815. LAC, Admiralty Fonds, ADM 52/3933.

145 John Aldersly to W.F.W. Owen, Enclosed in Thomas Payne to Croker, no date. LAC, Admiralty Fonds, ADM 1/2263.

146 W.F.W. Owen to Croker, 21 February 1816. LAC, Admiralty Fonds, ADM 1/2265. *Sauk* and *Confiance* wintered at Drummond Island, while *Surprize* was at Nottawasaga.

147 A "quarterman of shipwrights" is a supervisory role, similar to a foreman.

148 E.W.C.R. Owen, "Revised Naval Civil Establishments," 6 October 1815. LAC, Record Group 8, Series III, vol. 5.

149 E.W.C.R. Owen, "General Instructions for the Commander of the Naval Establishment upon Lake Erie," 12 October 1815. LAC, Admiralty Fonds, ADM 1/2264.

150 E.W.C.R. Owen, "General Instructions for the Commander of the Naval Establishment upon Lake Erie," 12 October 1815. LAC, Admiralty Fonds, ADM 1/2264.

151 E.W.C.R. Owen, "General Instructions for the Commander of the Naval Establishment upon Lake Erie," 12 October 1815. LAC, Admiralty Fonds, ADM 1/2264.

152 Since the "mole" would have been used to lay the ships up for the winter, it was presumably similar to a dock or pier.

153 E.W.C.R. Owen to W.F.W. Owen, 5 November 1815. LAC, Admiralty Fonds, ADM 1/2264.

154 James Childs, "Log of the Proceedings onboard H.M. Schooner *Tecumseth* on Lake Erie Between the 13th of August 1815 and the 13th November 1816," 10 November 1815, 11 November 1815, 12 November 1815, 13 November 1815. LAC, Admiralty Fonds, ADM 52/3933.

155 John Jewell, "A Return of all the Boats and Batteaux Belonging to His Majesty's Naval Establishment Lake Erie and Not Attached to Vessels," 31 December 1815. LAC, Admiralty Fonds, ADM 1/2265.

156 James Childs, "Log of the Proceedings onboard H.M. Schooner *Tecumseth* on Lake Erie Between the 13th of August 1815 and 13th November 1816," 12 November 1815. LAC, Admiralty Fonds, ADM 52/3933.

157 James Childs, "Log of the Proceedings onboard H.M. Schooner *Tecumseth* on Lake Erie Between the 13th of August 1815 and 13th November 1816," 13 November 1815. LAC, Admiralty Fonds, ADM 52/3933.

158 James Childs, "Log of the Proceedings onboard H.M. Schooner *Tecumseth* on Lake Erie Between the 13th of August 1815 and 13th November 1816," 18 November 1815. LAC, Admiralty Fonds, ADM 52/3933.

159 James Childs, "Log of the Proceedings onboard H.M. Schooner *Tecumseth* on Lake Erie Between the 13th of August 1815 and 13th November 1816," 20 December 1815, 21 December 1815. LAC, Admiralty Fonds, ADM 52/3933.

160 W.F.W. Owen to the Respective Captains and Commanders of His Majesty's Ships and Vessels on the Lakes of Canada," 8 April 1816. LAC, Admiralty Fonds, ADM 1/2266.

161 James Childs, "Log of the Proceedings onboard H.M. Schooner *Tecumseth* on Lake Erie Between the 13th of August 1815 and 13th November 1816," 29 November 1815. LAC, Admiralty Fonds, ADM 52/3933.

162 James Childs, "Log of the Proceedings onboard H.M. Schooner *Tecumseth* on Lake Erie Between the 13th of August 1815 and 13th November 1816," 22 September 1815. LAC, Admiralty Fonds, ADM 52/3933.

163 John Jewell, "Return of Work at Grand River," 31 December 1815. LAC, Admiralty Fonds, ADM 1/2265.

164 John Jewell, "Return of Work at Grand River," 31 December 1815. LAC, Admiralty Fonds, ADM 1/2265.

165 John Jewell, "Return of Work at Grand River," 31 December 1815. LAC, Admiralty Fonds, ADM 1/2265.

166 James Childs, "Log of the Proceedings onboard H.M. Schooner *Tecumseth* on Lake Erie Between the 13th of August 1815 and 13th November 1816," 7 May 1816. LAC, Admiralty Fonds, ADM 52/3933.

167 E.W.C.R. Owen, "General Instructions No. 2 for the Commander of the Naval Establishment upon Lake Erie," 12 October 1815. LAC, Admiralty Fonds, ADM 1/2264.

168 James Childs, "Log of the Proceedings onboard H.M. Schooner *Tecumseth* on Lake Erie Between the 13th of August 1815 and 13th November 1816," 7 December 1815. LAC, Admiralty Fonds, ADM 52/3933.

169 James Childs, "Log of the Proceedings onboard H.M. Schooner *Tecumseth* on Lake Erie Between the 13th of August 1815 and 13th November 1816," 18 January 1816. LAC, Admiralty Fonds, ADM 52/3933.

170 James Childs, "Log of the Proceedings onboard H.M. Schooner *Tecumseth* on Lake Erie Between the 13th of August 1815 and 13th November 1816," 10 March 1816, 12 March 1816, 23 March 1816. LAC, Admiralty Fonds, ADM 52/3933.

171 James Childs, "Log of the Proceedings onboard H.M. Schooner *Tecumseth* on Lake Erie Between the 13th of August 1815 and 13th November 1816," 23 March 1816, 30 March 1816, 2 April 1816, 3 April 1816. LAC, Admiralty Fonds, ADM 52/3933.

172 James Childs, "Log of the Proceedings onboard H.M. Schooner *Tecumseth* on Lake Erie Between the 13th of August 1815 and 13th November 1816," 4 April 1816. LAC, Admiralty Fonds, ADM 52/3933.

173 James Childs, "Log of the Proceedings onboard H.M. Schooner *Tecumseth* on Lake Erie Between the 13th of August 1815 and 13th November 1816," 18 April 1816. LAC, Admiralty Fonds, ADM 52/3933.

174 James Childs, "Log of the Proceedings onboard H. M. Schooner *Tecumseth* on Lake Erie Between the 13th of August 1815 and 13th November 1816," 20 April 1816, 21 April 1816, 22 April 1816. LAC, Admiralty Fonds, ADM 52/3933.

175 James Childs, "Log of the Proceedings onboard H.M. Schooner *Tecumseth* on Lake Erie Between the 13th of August 1815 and 13th November 1816," 22 April 1816. LAC, Admiralty Fonds, ADM 52/3933.

176 James Childs, "Log of the Proceedings onboard H.M. Schooner *Tecumseth* on Lake Erie Between the 13th of August 1815 and 13th November 1816," 22 April 1816. LAC, Admiralty Fonds, ADM 52/3933.

177 James Childs, "Log of the Proceedings onboard H.M. Schooner *Tecumseth* on Lake Erie Between the 13th of August 1815 and 13th November 1816," 23 April 1816. LAC, Admiralty Fonds, ADM 52/3933.

178 James Childs, "Log of the Proceedings onboard H.M. Schooner *Tecumseth* on Lake Erie Between the 13th of August 1815 and 13th November 1816," 24 April 1816. LAC, Admiralty Fonds, ADM 52/3933.

179 James Childs, "Log of the Proceedings onboard H.M. Schooner *Tecumseth* on Lake Erie Between the 13th of August 1815 and 13th November 1816," 27 April 1816. LAC, Admiralty Fonds, ADM 52/3933.

180 James Childs, "Log of the Proceedings onboard H.M. Schooner *Tecumseth* on Lake Erie Between the 13th of August 1815 and 13th November 1816," 27 April 1816. LAC, Admiralty Fonds, ADM 52/3933.

181 The Royal Navy's daily rum ration continued until 1970.

182 James Childs, "Log of the Proceedings onboard H.M. Schooner *Tecumseth* on Lake Erie Between the 13th of August 1815 and 13th November 1816," 27 April 1816. LAC, Admiralty Fonds, ADM 52/3933.

183 "Log of the Proceedings on Board HM Schooner/Brigantine *Newash* on Lake Erie, 13 August 1815 – 30 June 1817," 28 April 1816, 29 April 1816. PRO, Admiralty Fonds, ADM 51/2607.

184 "Log of the Proceedings on Board HM Schooner/Brigantine *Newash* on Lake Erie, 13 August 1815 – 30 June 1817," 29 April 1816. PRO, Admiralty Fonds, ADM 51/2607.

185 "Log of the Proceedings on Board HM Schooner/Brigantine *Newash* on Lake Erie, 13 August 1815 – 30 June 1817," 30 April 1816. PRO, Admiralty Fonds, ADM 51/2607.

186 "Log of the Proceedings on Board HM Schooner/Brigantine *Newash* on Lake Erie, 13 August 1815 – 30 June 1817," 1 May 1816. PRO, Admiralty Fonds, ADM 51/2607.

187 W.F.W. Owen to Bouchier, 31 March 1816. LAC, Admiralty Fonds, ADM 1/2266.

188 L. Farrington, *The Decline of Naval Bases on the Lakes of Canada, 1815 – 1834*, 10.

189 Henry Kent, "Log of H.M. Brigantine *Newash* on the Lakes Erie and Huron Between the 14th of November 1816 and 30th June 1817," 17 November 1816. LAC, Admiralty Fonds, ADM 52/4548.

190 Henry Kent, "Log of H.M. Brigantine *Newash* on the Lakes Erie and Huron Between the 14th of November 1816 and 30th June 1817," 13 December 1816. LAC, Admiralty Fonds, ADM 52/4548.

191 See Henry Kent, "Log of H.M. Brigantine *Newash* on the Lakes Erie and Huron Between the 14th of November 1816 and 30th June 1817," 25 December 1816, 16 January 1817, 20 January 1817, 28 January 1817, 31 January 1817, 10 February 1817. LAC, Admiralty Fonds, ADM 52/4548.

- 192 Robert Hall to Navy Board, 26 September 1816. LAC, Admiralty Fonds, ADM 106/1997.
- 193 Officer's Service Record, Captain Thomas Bushby. PRO, Admiralty Fonds, ADM 196/13.
- 194 Officer's Service Record, Lieutenant Abraham Whitehead. PRO, Admiralty Fonds, ADM 196/6.
- 195 W.F.W. Owen to Drummond, 21 April 1816. LAC, Admiralty Fonds, ADM 1/2266.
- 196 William Bouchier, "Extract of a letter from Captain W. Bouchier Commanding His Majesty's Naval Establishment on Lake Erie to Captain W.F.W. Owen, Senior Officer on the Lakes of Canada, dated Grand River 2 March 1816." LAC, Admiralty Fonds, ADM 1/2266.
- 197 William Bouchier, "Extract of a letter from Captain W. Bouchier Commanding His Majesty's Naval Establishment on Lake Erie to Captain W.F.W. Owen, Senior Officer on the Lakes of Canada, dated Grand River 2 March 1816." LAC, Admiralty Fonds, ADM 1/2266.
- 198 William Bouchier to Baumgardt, enclosed in William Baumgardt to Bagot, 5 September 1816. LAC, Bagot Papers, Military Group 24, Series A13, vol. 1.
- 199 W.F.W. Owen, "Extract of a letter from Captain [W.F.W.] Owen to Lieutenant Governor Gore, dated Kingston Naval Yard 21 March 1816." LAC, Admiralty Fonds, ADM 1/2266.
- 200 W.F.W. Owen, "Extract of a letter from Captain [W.F.W.] Owen to Lieutenant Governor Gore, dated Kingston Naval Yard 21 March 1816." LAC, Admiralty Fonds, ADM 1/2266.
- 201 Darcy Boulton, "Case for the Opinion of the Attourney [sic] General respecting Seizures or Searches on the Lakes in Canada by the Navy." LAC, Admiralty Fonds, ADM 1/2266.
- 202 William Bouchier to the Commanding Officers of H.M. Vessels on Lake Erie, 23 July 1816. LAC, Bagot Papers, Military Group 24, Series A13, vol. 1.
- 203 William Bouchier to the Commanding Officers of H.M. Vessels on Lake Erie, 23 July 1816, enclosed in William Baumgardt to Bagot, 5 September 1816. LAC, Bagot Papers, Military Group 24, Series A13, vol. 1.
- 204 Henry Kent to Bouchier, 28 July 1816, enclosed in William Baumgardt to Bagot, 5 September 1816. LAC, Bagot Papers, Military Group 24, Series A13, vol. 1.
- 205 See James Childs, "Log of the Proceedings onboard H.M. Schooner *Tecumseth* on Lake Erie Between the 13th of August 1815 and 13th November 1816," 6 July 1816, 7 July 1816. LAC, Admiralty Fonds, ADM 52/3933; Henry Kent to Bouchier, 28 July 1816, enclosed in William Baumgardt to Bagot, 5 September 1816. LAC, Bagot Papers, Military Group 24, Series A13, vol. 1.
- 206 Charles Bagot to Sherbrooke and Commodore E.W.C.R. Owen, 14 August 1816. LAC, Bagot Papers, Military Group 24, Series A13, vol. 1.
- 207 Henry Kent to Bouchier, 28 July 1816, enclosed in William Baumgardt to Bagot, 5 September 1816. LAC, Bagot Papers, Military Group 24, Series A13, vol. 1.

208 This wording is significant, as the border between the United States and Canada was to follow the middle of the border lakes, and split the main channel of passage between them. Interestingly, today the channel between Bois Blanc Island and the Canadian mainland is used for north-bound traffic. The channel to the west of Bois Blanc Island is used for south-bound traffic. Bois Blanc Island (now called Boblo Island) itself is Canadian.

209 Lewis Cass to the Officer Commanding His Britannic Majesty's Schooner *Tecumseth*, n.d., enclosed in William Baumgardt to Bagot, 5 September 1816. LAC, Bagot Papers, Military Group 24, Series A13, vol. 1.

210 Lewis Cass to the Officer Commanding His Britannic Majesty's Schooner *Tecumseth*, n.d., enclosed in William Baumgardt to Bagot, 5 September 1816. LAC, Bagot Papers, Military Group 24, Series A13, vol. 1.

211 William Baumgardt to Bouchier, 5 September 1816, enclosed in William Baumgardt to Bagot, 5 September 1816. LAC, Bagot Papers, Military Group 24, Series A13, vol. 1.

212 James Monroe to Bagot, 2 August 1816. LAC, Bagot Papers, Military Group 24, Series A13, vol. 14.

213 James Monroe to Bagot, 2 August 1816. LAC, Bagot Papers, Military Group 24, Series A13, vol. 14.

214 W.F.W. Owen to Baumgardt, 3 September 1816, enclosed in William Baumgardt to Bagot, 5 September 1816. LAC, Bagot Papers, Military Group 24, Series A13, vol. 1.

215 W.F.W. Owen to Baumgardt, 3 September 1816, enclosed in William Baumgardt to Bagot, 5 September 1816. LAC, Bagot Papers, Military Group 24, Series A13, vol. 1.

216 W.F.W. Owen to Baumgardt, 3 September 1816, enclosed in William Baumgardt to Bagot, 5 September 1816. LAC, Bagot Papers, Military Group 24, Series A13, vol. 1.

217 James Monroe to Bagot, 2 August 1816. LAC, Bagot Papers, Military Group 24, Series A13, vol. 14.

218 Charles Bagot, "Bagot Agreement," 28 April 1816. LAC, Bagot Papers, Military Group 24, Series A13, vol. 14.

219 For full text of the agreement, see Appendix C.

220 Henry Kent, "Log of H.M. Brigantine *Newash* on the Lakes Erie and Huron Between the 14th of November 1816 and 30th June 1817," 18 June 1817. LAC, Admiralty Fonds, ADM 52/4548.

221 Abraham Whitehead, "Log of the Proceedings of H.M. Schooner *Tecumseth* Commencing November 14th 1816 and ending June 30th 1817," 19 June 1817. LAC, Admiralty Fonds, ADM 51/2072.

222 Henry Kent, "Log of H.M. Brigantine *Newash* on the Lakes Erie and Huron Between the 14th of November 1816 and 30th June 1817," 21 June 1817. LAC, Admiralty Fonds, ADM 52/4548.

223 Abraham Whitehead, "Log of the Proceedings of H.M. Schooner *Tecumseth* Commencing November 14th 1816 and ending June 30th 1817," 21 June 1817. LAC, Admiralty Fonds, ADM 51/2072.

224 Henry Kent, "Log of H.M. Brigantine *Newash* on the Lakes Erie and Huron Between the 14th of November 1816 and 30th June 1817," 23 June 1817, 24 June 1817. LAC, Admiralty Fonds, ADM 52/4548.

- 225 Henry Kent, "Log of H.M. Brigantine *Newash* on the Lakes Erie and Huron Between the 14th of November 1816 and 30th June 1817," 24 June 1817. LAC, Admiralty Fonds, ADM 52/4548.
- 226 Henry Kent, "Log of H.M. Brigantine *Newash* on the Lakes Erie and Huron Between the 14th of November 1816 and 30th June 1817," 30 June 1817. LAC, Admiralty Fonds, ADM 52/4548; Abraham Whitehead, "Log of the Proceedings of H.M. Schooner *Tecumseth* Commencing November 14th 1816 and ending June 30th 1817," 30 June 1817. LAC, Admiralty Fonds, ADM 51/2072.
- 227 "Survey of His Majesty's Buildings and Wharves at Penetanguishene, on Lake Huron," 22 September 1820. LAC, Admiralty Fonds, ADM 106/1997.
- 228 Robert Barrie to his mother, 14 September 1819. Royal Military College, Robert Barrie Correspondence 1819 – 1828.
- 229 Robert Barrie to Commissioners, 25 August 1819, quoted in L. Farrington, "The Decline of Naval Bases on the Lakes of Canada, 1815 – 1834," 6.
- 230 Robert Adams, William Wilson, and C. Thomas, "A Survey of His Majesty's Brigantine *Newash* Pursuant to an Order from Commissioner Barrie C.B. to Mr. Robert Adams Quartermaster of Shipwrights," 15 September 1819. LAC, Admiralty Fonds, ADM 106/1998.
- 231 T.F. Hawkes and William Morgan, "Survey of H.M. Schooner *Tecumseth*, Taken Afloat," n.d. LAC, Admiralty Fonds, ADM 106/1998; T.F. Hawkes and William Morgan, "Survey of H.M. Schooner *Newash*, Taken Afloat," n.d. LAC, Admiralty Fonds, ADM 106/1998.
- 232 Robert Adams, William Wilson, C. Thomas, "A Survey of His Majesty's Brigantine *Newash* Pursuant to an Order from Commissioner Barrie C.B. to Mr. Robert Adams Quartermaster of Shipwrights," 15 September 1819. LAC, Admiralty Fonds, ADM 106/1998.
- 233 John Croker to Bushby, 10 February 1821. PRO, Admiralty Fonds, ADM 2/1585.
- 234 L. Farrington, "The Decline of Naval Bases on the Lakes of Canada, 1815 – 1834," 6, 35.
- 235 Henry Kent to Croker, 29 April 1830. LAC, Admiralty Fonds, ADM 1/2031; Officer's Service Record, Captain Henry Kent. PRO, Admiralty Fonds, ADM 196/5 Part 1.
- 236 H.D.C. Douglas, William Woodin, J. McNicoll, Samuel Richardson and William Wilson, "Survey on His Majesty's Vessels and Boats at Penetanguishene," 31 December 1827. LAC, Admiralty Fonds, ADM 106/2000.
- 237 Samuel Richardson, "A List of Naval Stores which Commodore Barrie C.B. intends recommending to be disposed of by Public Sale at Hollands Landing and Penetanguishene," 23 August 1831. LAC, Admiralty Fonds, ADM 106/2002.
- 238 L. Farrington, "The Decline of Naval Bases on the Lakes of Canada, 1815 – 1834," 10.
- 239 L. Farrington, "The Decline of Naval Bases on the Lakes of Canada, 1815 – 1834," 11.
- 240 Terry McDonald, "It is Impossible for His Majesty's Government to Withdraw from these Dominions' Britain and the Defence of Canada, 1813 to 1834," 53.

241 U.S. Department of State, Pro memoria note recording consultations between the United States and Canada on same (April 22, 2003).

242 On the American side of the border, the remains of the brig *Lawrence*, from the Battle of Lake Erie, was recovered in 1875; her sister ship *Niagara* was salvaged in 1913, for the centennial of the battle.

243 C.H.J. Snider, "Recovery of H.M.S. *Tecumseth*," 98.

244 C.H.J. Snider, "Recovery of H.M.S. *Tecumseth*," 98.

245 Howard I. Chapelle, *The History of the American Sailing Navy*, 270 – 272; W.W. Dobbins, *The History of the Battle of Lake Erie and Reminiscences of Flagships "Lawrence" and "Niagara"*, 33. There has been some confusion as to *Tigress*'s identity. Historian Howard I. Chapelle proposed that the schooner *Amelia*, which had been purchased for the American Lake Erie fleet, was renamed *Tigress*. Both Captain W.W. Dobbins, son of American sailor Daniel Dobbins, and shipwright Noah Brown have stated that Brown built *Tigress*, and that *Amelia* was sunk in Erie harbor after being condemned during survey.

246 C.H.J. Snider, "Recovery of H.M.S. *Tecumseth*," 99.

247 C.H.J. Snider, "Recovery of H.M.S. *Tecumseth*," 100.

248 C.H.J. Snider, "Recovery of H.M.S. *Tecumseth*," 100.

249 C.H.J. Snider, "Recovery of H.M.S. *Tecumseth*," 101.

250 C.H.J. Snider, "Recovery of H.M.S. *Tecumseth*," 101. These experts included C.H.J. Snider, W.M. Prentice, Lieutenant Rowley W. Murphy, John R. Stevens, and a Lieutenant Russell from the Naval Museum at Halifax.

251 C.H.J. Snider, "Recovery of H.M.S. *Tecumseth*," 103.

252 C.H.J. Snider, "Schooner Days," MXXIX, MCXXI, MCXXVIII, MCXXXI. Great Lakes Historical Society, Dana Thomas Bowen Collection.

253 H.F. Pullen, *The March of the Seamen*, 5.

254 John R. Stevens, "The Story of H.M. Armed Schooner *Tecumseth*," 28 – 29.

255 Charles Hett, "Report on Visit to Penetanguishene – October 6th, 1976." Private Collection of Kevin J. Crisman, College Station, TX.

256 Charles Hett, "Report on Visit to Penetanguishene – October 6th, 1976." Private Collection of Kevin J. Crisman, College Station, TX.

257 Charles Hett, "Report on Visit to Penetanguishene – October 6th, 1976." Private Collection of Kevin J. Crisman, College Station, TX.

258 C. Nepean Longridge, *The Anatomy of Nelson's Ships*, 7.

259 C. Nepean Longridge, *The Anatomy of Nelson's Ships*, 13 – 14.

- 260 Mary-Lou Florian to Hett, 5 November 1976. "Memorandum on Wood Samples from HMS *Tecumseh* [sic]," #2. Private Collection of Kevin J. Crisman, College Station, TX.
- 261 Erich Heinold, "*Tecumseth* Scantling List." Private Collection of Kevin J. Crisman, College Station, TX.
- 262 Considering the length of time that *Tecumseth* spent aground in Spring 1816, a false keel may have been necessary. Without it, the proper keel of the vessel may have been scraped down to nothing.
- 263 J. Richard Steffy, *Wooden Ship Building*, 292, fig. G-11b.
- 264 Comparison of figs. 18 and 19 shows that the port and starboard views of the keel/stem joint are distinctly different; the keel projects further on the starboard face than it does on the port face. Without disassembling these timbers, this is the only evidence that confirms the type of scarf used in this joint.
- 265 John R. Stevens, "The Story of H.M. Armed Schooner *Tecumseth*," 23.
- 266 Erich Heinold, "*Tecumseth* Scantling List." Private Collection of Kevin J. Crisman, College Station, TX.
- 267 Eric Emery, "*Newash* Project: Stem – Stbd Profile & Plan View," July 8 – 10, 13 – 14, 1998. Private Collection of Kevin J. Crisman, College Station, TX.
- 268 Erich Heinold, "*Tecumseth* Scantling List." Private Collection of Kevin J. Crisman, College Station, TX.
- 269 John R. Stevens, "The Story of H.M. Armed Schooner *Tecumseth*," 23.
- 270 Bryan Atchison, "Horseshoe Plate (Port)," 23 June 1997. Private Collection of Kevin Crisman, College Station, TX. Field notes give the following diameters: two bolts measure 1.25 inches (3.18 cm), while the other three are 0.75 inches (1.91 cm), 1.38 inches (3.49 cm) and 0.83 inches (2.22 cm).
- 271 C. Nepean Longridge, *The Anatomy of Nelson's Ships*, 13.
- 272 These measurements were taken from the more-accessible starboard plate.
- 273 C. Nepean Longridge, *The Anatomy of Nelson's Ships*, 11.
- 274 Erich Heinold, "*Tecumseth* Scantling List." Private Collection of Kevin J. Crisman, College Station, TX.
- 275 John R. Stevens, "The Story of H.M. Armed Schooner *Tecumseth*," 23; Rowley Murphy, "Resurrection at Penetanguishene," 5.
- 276 Erich Heinold, "H.M. Schooner *Newash* Wreck Plan." Private Collection of Kevin J. Crisman, College Station, TX.
- 277 Mary-Lou Florian to Hett, 5 November 1976. "Memorandum on Wood Samples from HMS *Tecumseh* [sic]," #4. Private Collection of Kevin J. Crisman, College Station, TX.
- 278 John R. Stevens, "The Story of H.M. Armed Schooner *Tecumseth*," 23.

- 279 Mary-Lou Florian to Hett, 5 November 1976. "Memorandum on Wood Samples from HMS *Tecumseh* [sic]," #3. Private Collection of Kevin J. Crisman, College Station, TX.
- 280 Chris P. "Mast Piece," 30 June 1997. Private Collection of Kevin J. Crisman, College Station, TX. The identification of these marks as hatchet marks is from Heinold's field notes from the 1997 season.
- 281 Some publications refer to this assembly as a "shelf" or "shelf-clamp."
- 282 John R. Stevens, "The Story of H.M. Armed Schooner *Tecumseth*," 24.
- 283 John R. Stevens, "The Story of H.M. Armed Schooner *Tecumseth*," 24, 29.
- 284 John R. Stevens, "The Story of H.M. Armed Schooner *Tecumseth*," 24.
- 285 Bryan Atchison, "Deck Beam," 28 June 1997. Private Collection of Kevin J. Crisman, College Station, TX.
- 286 E.B. Emery, "Clamp/Waterway," 15 – 16 July 1998. Private Collection of Kevin J. Crisman, College Station, TX.
- 287 Chris P. "Deadeye on CA-1-U," 30 June 1997. Private Collection of Kevin J. Crisman, College Station, TX.
- 288 Mary-Lou Florian to Hett, 5 November 1976. "Memorandum on Wood Samples from HMS *Tecumseh* [sic]," #1. Private Collection of Kevin J. Crisman, College Station, TX.
- 289 These measurements were taken from field notes recorded during Erich Heinold's 1997 field season, now among Kevin Crisman's personal files regarding War of 1812 shipwrecks, as well as measurements taken during the author's 2007 and 2008 investigations.
- 290 Mary-Lou Florian to Hett, 5 November 1976. "Memorandum on Wood Samples from HMS *Tecumseh* [sic]," #5. Private Collection of Kevin J. Crisman, College Station, TX; John R. Stevens, "The Story of H.M. Armed Schooner *Tecumseth*," 23.
- 291 Navy Office to the Respective Officers of His Majesty's Yard at Quebec, 12 June 1815. LAC, Record Group 8, Series III, vol. 1.
- 292 James Walker to Laws, 22 August 1815. LAC, Record Group 8, Series III, vol. 8. Naval depots at Quebec and Montreal had an abundance of sheet copper after the war, which was not needed for lake service.
- 293 Rowley Murphy, "Resurrection at Penetanguishene," 6.
- 294 Rowley Murphy, "Resurrection at Penetanguishene," 6.
- 295 James Childs, "Log of the Proceedings onboard H.M. Schooner *Tecumseth* on Lake Erie Between the 13th of August 1815 and 13th of November 1816," 23 July 1816. LAC, Admiralty Fonds, ADM 52/3933.
- 296 Rowley Murphy, "Resurrection at Penetanguishene," 7.
- 297 Kevin J. Crisman, *The Eagle*, 255.

298 Kevin J. Crisman, *The Eagle*, 204 – 205; Robert Seppings, “On a New Principle of Constructing His Majesty’s Ships of War,” 285 – 302; Robert Seppings, “On a New Principle of Constructing Ships in the Mercantile Navy,” 133 – 143.

299 John R. Stevens, “The Story of H.M. Armed Schooner *Tecumseth*,” 24.

300 Kevin J. Crisman, *The Eagle*, 147.

301 Of course, the vessels may have had false keels, which could have offered those few inches of lateral resistance. Archaeological evidence of such is scanty, and no false keel appears on the construction draft, but that would not necessarily rule such a feature out.

302 For the purposes of this hull analysis, the *Newash/Tecumseth* hull will be considered as a singular entity.

303 Howard I. Chapelle, *The Search for Speed under Sail*, 46.

304 Howard I. Chapelle, *The Search for Speed under Sail*, 48.

305 Charles Desmond, *Naval Architecture Simplified*, 32.

306 Howard I. Chapelle, *The Search for Speed under Sail*, 398 – 399.

307 Howard I. Chapelle, *The Search for Speed under Sail*, 398 – 399.

308 Charles Desmond, *Naval Architecture Simplified*, 32. For obvious reasons, there is a practical limitation on how far the raking of a stem could be carried out on a vessel, though there is no expressed limit.

309 Charles Desmond, *Naval Architecture Simplified*, 32. This same theory is used in all types of racing where “drafting” can be seen.

310 Charles Desmond, *Naval Architecture Simplified*, 33.

311 Howard I. Chapelle, *Boatbuilding*, 193.

312 Howard I. Chapelle, *The Search for Speed under Sail*, 399.

313 Charles Desmond, *Naval Architecture Simplified*, 31.

314 The salt water displacement is given only for comparison purposes with the hulls analyzed in Howard I. Chapelle’s *The Search for Speed under Sail: 1750 – 1855*, some of which are reprinted in Appendix D. Since *Newash* and *Tecumseth* only saw duty on the fresh water of the Great Lakes, the fresh water displacement is the only one that would have truly affected the hulls.

315 Howard I. Chapelle, *The Search for Speed under Sail*. 45.

316 Howard I. Chapelle, *The Search for Speed under Sail*. 408.

317 The theory that correlates waterline lengths and potential speeds is also responsible for methods of handicapping sailing races.

318 Howard I. Chapelle, *The Search for Speed under Sail*, 29.

319 Howard I. Chapelle, *The Search for Speed under Sail*, 30.

320 Richard A. Block, *Limited Master, Mate, & Operator License Study Course*, STAB-46.

321 The calculation for the actual weight necessary for lightening the hull 22 inches (55.89 cm) is not as simple as multiplying 2.66 tons by 22, which yields a weight of 58.52 tons (59,584 kg). The TPI changes at different drafts, as the waterplane area at these drafts would be different. Rather than calculating the waterplane area for each inch the hull was lightened, the weight has been estimated as at least 50 tons.

322 Again, since the waterplane area differs at different depths, 2 inches (5.08 cm) is estimated.

323 Richard A. Block, *Limited Master, Mate, & Operator License Study Course*, STAB-5.

324 Richard A. Block, *Limited Master, Mate, & Operator License Study Course*, STAB-52.

325 This is not exactly correct, since the geometry of the submerged hull changes as it is heeled to either side, changing the position of the center of buoyancy. As the center of buoyancy shifts, it also changes in intensity. The hull would actually have to heel slightly beyond 18° for deck-edge immersion to occur. For the purposes of this discussion, however, the calculation of 18° will suffice.

326 Howard I. Chapelle, *The Search for Speed under Sail*, 213.

327 Richard A. Block, *Limited Master, Mate, & Operator License Study Course*, STAB-37.

328 Richard A. Block, *Limited Master, Mate, & Operator License Study Course*, STAB-37.

329 David R. Steel, *Steel's Elements of Mastmaking, Sailmaking, and Rigging*.

330 John Fincham, *A Treatise on Masting Ships and Mast Making*.

331 Thomas Bushby, "An Account of Rigging and Sails Belonging to His Majesty's Schooner *Newash*," 19 September 1815. LAC, Record Group 8, Series III, vol. 5. The rigging warrant is reproduced in Appendix E.

332 "Log of the Proceedings on Board HM Schooner/Brigantine *Newash* on Lake Erie, 13 August 1815 – 30 June 1817," 15 August 1815, 18 August 1815, 23 August 1815, 24 August 1815. PRO, Admiralty Fonds, ADM 51/2607.

333 Howard I. Chapelle, *The Baltimore Clipper*, 161, 179-185. All of the dimensions of the spars correspond to the ratios provided by Chapelle except the bowsprit and jibboom. Chapelle's ratios, which were based on Fincham's various examples, are far shorter than the actual numbers reported in Fincham's treatise. For this reconstruction, both bowsprit and jibboom were lengthened, to a dimension closer to those given by Fincham directly.

334 For these calculations, see Appendix F.

335 Walter Rybka, Captain of the U.S. Brig *Niagara*, has offered an explanation for why hearts and deadeyes are used where they are. It is included in Appendix G.

336 Later schooners referred to this as a "triotic stay."

337 The measurement on a block refers to the length of its cheeks. A 9-inch (22.87 cm) single sheave block and a 9-inch (22.87 cm) double sheave block had the same size outer cheeks.

338 The rigging warrant includes entries for these blocks, but does not specifically mention the tackles or falls of the deck stays in the cordage section. The warrant does list “Main Tackles” which may refer to falls for the runners as well as the deck stays. No number is given for any of the entries, though it may be assumed that several refer to at least two of the items listed.

339 This set up is called a “runner tackle” in Darcy Lever, *The Young Sea Officer’s Sea Anchor*, 16. The full set up of a breast backstay is shown on page 29.

340 In Bushby’s logbook, the two sides of a ship were referred to as “starboard” and “larboard,” rather than the later “starboard” and “port.”

341 Hervey Garrett Smith, *The Marlinspike Sailor*, 37, 40.

342 James Childs, “Log of the Proceedings onboard H.M. Schooner *Tecumseth* on Lake Erie Between the 13th of August 1815 and 13th November 1816,” 7 September 1815. LAC, Admiralty Fonds, ADM 52/3933.

343 James Childs, “Log of the Proceedings onboard H.M. Schooner *Tecumseth* on Lake Erie Between the 13th of August 1815 and 13th November 1816,” 28 August 1815. LAC, Admiralty Fonds, ADM 52/3933.

344 James Childs, “Log of the Proceedings onboard H.M. Schooner *Tecumseth* on Lake Erie Between the 13th of August 1815 and 13th November 1816,” 20 September 1815. LAC, Admiralty Fonds, ADM 52/3933.

345 James Childs, “Log of the Proceedings onboard H.M. Schooner *Tecumseth* on Lake Erie Between the 13th of August 1815 and 13th November 1816,” 27 November 1815, 30 September 1816. LAC, Admiralty Fonds, ADM 52/3933.

346 Austin M. Knight et al, *Modern Seamanship*, 534. In the case of standing rigging, the loss of flexibility was preferable.

347 James Childs, “Log of the Proceedings onboard H.M. Schooner *Tecumseth* on Lake Erie Between the 13th of August 1815 and 13th November 1816,” 18 August 1815, 14 September 1815, 28 March 1816. LAC, Admiralty Fonds, ADM 52/3933.

348 An example of swiftering shrouds can be seen in Darcy Lever, *The Young Sea Officer’s Sheet Anchor*, 25, Fig. 182.

349 The dumb sheave here is simply a notch cut into the end of the jibboom. Tension on the fore topgallant stay kept the line in place. By cutting only a notch, shipwrights were able to save on materials. Though the notch would have added more friction than a sheave, it was much simpler and quicker to rig than a regular sheave would have been.

350 Darcy Lever, *The Young Sea Officer’s Sheet Anchor*, 60, figs. 333 – 336.

351 Darcy Lever, *The Young Sea Officer’s Sheet Anchor*, 60, fig. 337.

352 Henry Kent, "Log of the Proceedings of H.M. Brigantine *Newash* on Lakes Erie and Huron Between the 14th of November 1816 and 30th June 1817," 19 May 1817; 5 June 1817. LAC, Admiralty Fonds, ADM 52/4548.

353 Fincham's dimensions for masts and spars of a common schooner also include a "square boom" which was used to extend the foot of the square-rigged foresail. Bushby's rigging warrant contains no references to such a spar, and so it has been omitted from this reconstruction.

354 Thomas Bushby, "An Account of Rigging and Sails Belonging to His Majesty's Schooner *Newash*," 19 September 1815. LAC, Record Group 8, Series III, vol. 5.

355 Thomas Bushby, "An Account of Rigging and Sails Belonging to His Majesty's Schooner *Newash*," 19 September 1815. LAC, Record Group 8, Series III, vol. 5.

356 Thomas Bushby, "An Account of Rigging and Sails Belonging to His Majesty's Schooner *Newash*," 19 September 1815. LAC, Record Group 8, Series III, vol. 5.

357 James Childs, "Log of the Proceedings onboard H.M. Schooner *Tecumseth* on Lake Erie Between the 13th of August 1815 and 13th November 1816," 7 June 1816. LAC, Admiralty Fonds, ADM 52/3933.

358 James Childs, "Log of the Proceedings onboard H.M. Schooner *Tecumseth* on Lake Erie Between the 13th of August 1815 and 13th November 1816," 28 August 1816. LAC, Admiralty Fonds, ADM 52/3933.

359 James Childs, "Log of the Proceedings onboard H.M. Schooner *Tecumseth* on Lake Erie Between the 13th of August 1815 and 13th November 1816," 12 June 1816, 12 July 1816. LAC, Admiralty Fonds, ADM 52/3933.

360 Darcy Lever, *The Young Sea Officer's Sheet Anchor*, 44.

361 Thomas Bushby, "An Account of Rigging and Sails Belonging to His Majesty's Schooner *Newash*," 19 September 1815. LAC, Record Group 8, Series III, vol. 5.

362 Darcy Lever, *The Young Sea Officer's Sheet Anchor*, 35.

363 Darcy Lever, *The Young Sea Officer's Sheet Anchor*, 34, fig. 221.

364 These are the blocks listed in Bushby's rigging warrant for the fore yard. The warrant does not mention any of the gear necessary for the main yards, since they were going to be replaced with a gaff topsail. The rigging for the main yards here has been taken from the rigging for the fore yards, assuming that the blocks and lines used were identical or similar.

365 Curiously, the rigging warrant lists 28 fathoms (168 feet or 51.22 m) of 2 ½-inch (6.35 cm) cordage for the fore topsail lifts, an extraordinarily long length of rope for lines which were apparently rigged without falls.

366 Darcy Lever, *The Young Sea Officer's Sheet Anchor*, 47. Such a setup, where the lifts ran through thimbles that were seized to the forward legs of their respective shrouds is given by Darcy Lever.

367 It has been supposed that the sister blocks were considered differently than the other blocks listed in the rigging warrant, perhaps due to the permanency of their placement.

368 Different size blocks might have also been used for the main topsail and topgallant rigging, which is not recorded in the warrant. Bushby's request for stores for six months includes two 5-inch (12.70 cm) double sheave blocks, six 7-inch (17.78 cm) double sheave blocks and twelve 7-inch (17.78 cm) single sheave blocks, though none of the lines specified call for such sizes. These may otherwise have been used for rigging handy billies or other tackles for various uses around the deck.

369 Thomas Bushby, "An Account of Rigging and Sails Belonging to His Majesty's Schooner *Newash*," 19 September 1815. LAC, Record Group 8, Series III, vol. 5.

370 Thomas Bushby, "An Account of Rigging and Sails Belonging to His Majesty's Schooner *Newash*," 19 September 1815. LAC, Record Group 8, Series III, vol. 5.

371 Darcy Lever, *The Young Sea Officer's Sheet Anchor*, 39, fig. 248.

372 Also spelled "clew."

373 Darcy Lever, *The Young Sea Officer's Sheet Anchor*, 57, figs. 321 – 322, 324.

374 Several historical documents mention enclosures of rigging dimensions, which could not be located.

375 Of course, if this sail was square-rigged, its versatility would be limited by the rigging that supported it. A fore-and-aft sail also has restrictions on its use, since it is not the preferred sail for certain conditions.

376 James Childs, "Log of the Proceedings onboard H.M. Schooner *Tecumseth* on Lake Erie Between the 13th of August 1815 and 13th November 1816," 22 February 1816. LAC, Admiralty Fonds, ADM 52/3933.

377 James Childs, "Log of the Proceedings onboard H.M. Schooner *Tecumseth* on Lake Erie Between the 13th of August 1815 and 13th November 1816," 23 February 1816, 23 February 1816, 24 February 1816, 26 February 1816 and 27 February 1816. LAC, Admiralty Fonds, ADM 52/3933.

378 James Childs, "Log of the Proceedings onboard H.M. Schooner *Tecumseth* on Lake Erie Between the 13th of August 1815 and 13th November 1816," 9 November 1815. LAC, Admiralty Fonds, ADM 52/3933.

379 James Childs, "Log of the Proceedings onboard H.M. Schooner *Tecumseth* on Lake Erie Between the 13th of August 1815 and 13th November 1816," 3 September 1815. LAC, Admiralty Fonds, ADM 52/3933; Henry Kent, "Log of H.M. Brigantine *Newash* on the Lakes Erie and Huron Between the 14th of November 1816 and 30th June 1817," 22 November 1816. LAC, Admiralty Fonds, ADM 52/4548.

380 Howard I. Chapelle, *The Baltimore Clipper*, 162 – 163. Individual sails were drawn using a number of proportions from Howard I. Chapelle's *The Baltimore Clipper*. These provided ratios of leeches, luffs, heads and feet of sails.

381 Howard I. Chapelle, *The Baltimore Clipper*, 160.

382 Howard I. Chapelle, *The Baltimore Clipper*, 160.

383 John Jewell, "Return of Work at Grand River," 31 December 1815. LAC, Admiralty Fonds, ADM 1/2265.

384 E.W.C.R. Owen, "General Instructions No. 2 for the Commander of the Naval Establishment upon Lake Erie," 12 October 1815. LAC, Admiralty Fonds, ADM 1/2264.

385 C.H.J. Snider, "Recovery of H.M.S. *Tecumseth*," 103.

386 Howard I. Chapelle, *The Baltimore Clipper*, 179.

387 Howard I. Chapelle, *The Baltimore Clipper*, 179-185. These numbers were reached by adding the hounded heights of the main and fore mast assemblies from Fincham's figures reprinted by Chapelle.

388 John Jewell, "Return of Work at Grand River," 31 December 1815. LAC, Admiralty Fonds, ADM 1/2265.

389 Howard I. Chapelle, *The Baltimore Clipper*, 182. These were calculated by averaging the 70-foot (21.34 m) and 71-foot (21.65 m) dimensions for a common schooner.

390 Howard I. Chapelle, *The Baltimore Clipper*, 184. These were calculated by averaging the 70-foot (21.34 m) and 71-foot (21.65 m) dimensions for brigantines.

391 Darcy Lever, *The Young Sea Officer's Sheet Anchor*, 65.

392 Rowley Murphy, "Resurrection at Penetanguishene," 4.

393 Rowley Murphy, "Resurrection at Penetanguishene," 4.

394 Thomas Bushby, "An Account of Rigging and Sails Belonging to His Majesty's Schooner *Newash*," 19 September 1815. LAC, Record Group 8, Series III, vol. 5.

395 John Jewell, "Return of Work at Grand River," 31 December 1815. LAC, Admiralty Fonds, ADM 1/2265.

396 "Log of the Proceedings on Board HM Schooner/Brigantine *Newash* on Lake Erie, 13 August 1815 – 30 June 1817," 11 October 1815. PRO, Admiralty Fonds, ADM 51/2607.

397 Howard I. Chapelle, *The Baltimore Clipper*, 174.

398 E.W.C.R. Owen to Laws, 5 August 1815. LAC, Admiralty Fonds, ADM Record Group 8, Series III, vol. 5.

399 E.W.C.R. Owen to Laws, 4 October 1815. Reprinted in John R. Stevens, "The Story of H.M. Armed Schooner *Tecumseth*," 26.

REFERENCES

Primary Sources

Brady, William. *The Kedge-Anchor: or Young Sailors' Assistant*. 1847. Reprinted. Mineola, NY: Dover Publications, Inc., 2002.

Canada. Library and Archives of Canada. Admiralty Fonds. Canada, 1814 – 1816. ADM 106/1997.

———. Canada, 1817 – 1819. ADM 106/1998.

———. Canada, 1822 – 1823. ADM 106/2000.

———. Canada, 1828 – 1832. ADM 106/2002.

———. Captains' Logs: TECUMSETH, 14 November 1816 – 30 June 1817. ADM 51/2072.

———. Captains' Logs: TECUMSETH, 29 Oct 1816 – 13 November 1816. ADM 51/2502.

———. Letters from Captains, Surnames K: 1828 – 1831. ADM 1/2031.

- . Letters from Captains, Surnames O: 1815, nos. 1 – 70. ADM 1/2262.
- . Letters from Captains, Surnames O: 1815, nos. 71 – 114. ADM 1/2263.
- . Letters from Captains, Surnames O: 1816: nos. 1 – 50. ADM 1/2264.
- . Letters from Captains, Surnames O: 1816: nos. 51 – 80. ADM 1/2265.
- . Letters from Captains, Surnames O: 1816: nos. 81 – 112. ADM 1/2266.
- . Masters' Logs, TECUMSETH, 13 August 1815 – 13 November 1816. ADM 52/3933.
- . Masters' Logs, NEWARK [sic], 14 November 1816 – 30 June 1817. ADM 52/4548.
- Canada. Library and Archives of Canada. Bagot Papers. Military Group 24, Series A13, vol. 1.
- , vol. 14.
- Canada. Library and Archives of Canada. Record Group 8, Series III, vol. 1.

———, vol. 3.

———, vol. 4.

———, vol. 5.

———, vol. 8.

Canada. Royal Military College. Robert Barrie Correspondence, 1819 – 1828.

Fincham, John. *A Treatise on Mastng Ships and Mast Making*. 1829. Reprinted.

London: Conway Maritime Press Ltd., 1982.

Great Lakes Historical Society. Dana Thomas Bowen Collection.

Jefferson, Thomas. “American Memory, The Thomas Jefferson Collection.” Library of Congress, 2008. <http://www.memory.loc.gov> (accessed 28 April 2008).

Kent, Henry. “Extraordinary March of Lieutenant Henry Kent, from St. John’s, New Brunswick, to Kingston, in Upper Canada, being a distance of 900 Miles, in the depth of Winter.” *The Naval Chronicle for 1815 XXXIII* (1815): 1-9.

Lever, Darcy. *The Young Sea Officer's Sea Anchor: Or a Key to the Leading of Rigging and to Practical Seamanship*. 1819. Reprinted. Mineola, NY: Dover Publications, 1998.

Malloy, William, comp. *Treaties, Conventions, International Acts, Protocols and Agreements between the United States of America and Other Powers, 1776 – 1909*. Washington, D.C.: Government Printing Office, 1910.

A Naval Encyclopaedia: Comprising A Dictionary of Nautical Words and Phrases; Biographical Notices, and Records of Naval Officers; Special Articles on Naval Art and Science, Written Expressly for this Work by Officers and Others of Recognized Authority in the Branches Treated by Them. Together with Descriptions of the Principal Naval Stations and Seaports of the World. Philadelphia: L.R. Hammersly & Co., 1881.

Seppings, Robert. “On a New Principle of Constructing His Majesty’s Ships of War.” *Philosophical Transactions of the Royal Society of London* 104 (1814): 285 – 302.

———. “On a New Principle of Constructing Ships in the Mercantile Navy.” *Philosophical Transactions of the Royal Society of London* 110 (1820): 133 – 143.

Steel, David R. *Steel’s Elements of Mastmaking, Sailmaking, and Rigging*. 1794. Reissue by Claude S. Gill. Largo, FL: Edward W. Sweetman Co., 1982.

United Kingdom. Public Record Office. Admiralty Fonds. ADM 2/1585.

———. ADM, Reg. No. 4562, Box 64.

———. Captains' Logs: NEWASH, 13 August 1815 – 30 June 1817. ADM 51/2607.

———. Officers' Service Records: Officers [sic] Time of Service, Dates of Entry: 1777 – 1848, Latest Date of Discharge: 1866. ADM 196/6.

———. Officers' Service Records: Officers [sic] Time of Service, Date of Entry: 1780 – 1851, Latest Date of Discharge: 1857. ADM 196/3.

———. Officers' Service Records: Officers [sic] Time of Service, Date of Entry: 1782 – 1851, Latest Date of Discharge: 1875. ADM 196/5.

———. Officers' Service Records: Naval Cadets to Admirals, Dates of Entry: 1818 – 1857, Latest Date of Discharge: 1897. ADM 196/13.

United Kingdom. Public Record Office. Record Group 8, Series IC, vol. 370.

———, vol. 734.

———, vol. 735.

———, vol. 736.

Wood, William. *Select Documents of the Canadian War of 1812*, vol. III, part I.

Toronto: Champlain Society, 1926.

Secondary Sources

Block, Richard A., ed. *Limited Master, Mate, & Operator License Study Course*, Vol. 3.

Houma, LA: Marine Education Textbooks, Inc., 2001.

Chapelle, Howard I. *The Baltimore Clipper*. Salem, MA: The Marine Research Society, 1930.

———. *Boatbuilding*. New York: W.W. Norton & Co., Inc, 1941.

———. *History of the American Sailing Navy*. New York: Bonanza Books, 1949.

———. *The Search for Speed under Sail: 1750 – 1855*. New York: Bonanza Books, 1967.

Crisman, Kevin J. *The Eagle: An American Brig on Lake Champlain during the War of 1812*. Annapolis, MD: The Naval Institute Press, 1987.

Desmond, Charles. *Naval Architecture Simplified: Explained in Non-Technical Terms*, 2nd ed. New York: The Rudder Publishing Co., 1918.

Dobbins, W.W. *History of the Battle of Lake Erie (September 10, 1813) and Reminiscences of the Flagships "Lawrence" and "Niagara,"* 2nd ed. Erie, PA: Ashby Printing Company, 1913.

Farrington, L. "The Barry German Naval History Prize 1955: Subject; The Decline of Naval Bases on the Lakes of Canada, 1815 – 1834". N.p., n.d. Private Collection of Kevin J. Crisman.

Knight, Austin M., Ralph S. Wentworth, John V. Noel, Jr., Officers of the U.S. Naval Academy, Officers of the U.S. Coast Guard Academy, Officers and Civilian Specialists in the Bureau of Ships and in the Bureau of Naval Personnel, Navy Department and Frederick L. Caudle. *Modern Seamanship*, 12th ed. Princeton, NJ: D. Van Nostrand Company, Inc., 1959.

Longridge, C. Nepean. *The Anatomy of Nelson's Ships*. London: Percival Marshall & Co., 1955.

Masefield, John. *Sea Life in Nelson's Time*. 1907. Reissue by Kessinger Publishing, Whitefish, MT: Kessinger Publishing, 2007.

McDonald, Terry. "It is Impossible for His Majesty's Government to Withdraw from these Dominions' Britain and the Defence [sic] of Canada, 1813 to 1834." *Journal of Canadian Studies* 39.3 (2005): 40 – 59.

Murphy, Rowley. "Resurrection at Penetanguishene." *Inland Seas* X (1954): 3 – 8.

Pullen, H.F. *March of the Seamen*. Halifax: Maritime Museum of Canada, 1961.

Smith, Hervey Garrett. *The Marlinspike Sailor*. Clinton Corners, NY: John de Graff, Inc., 1986.

Snider, C.H.J. "Recovery of H.M.S. *Tecumseth* of the Upper Canada Naval Department, Succeeding His Majesty's Provincial Marine, at Penetanguishene, August 29, 1953." *Ontario History* xlvi, no. 2 (1954): 97 – 105.

Steffy, J. Richard. *Wooden Ship Building and the Interpretation of Shipwrecks*. College Station, TX: Texas A&M University Press, 1994.

Stevens, John R. “The Story of H.M. Armed Schooner *Tecumseth*.” In *March of the Seamen*, by H.F. Pullen, 23 – 29. Halifax, Nova Scotia: Maritime Museum of Canada, 1961.

Tucker, Spencer C. “The Carronade.” *U.S. Naval Institute Proceedings* August 1973: 65 – 70.

United States Army Corps of Engineers, “Detroit District – Detroit River.” U.S. Army Corps of Engineers, 2006. http://www.lre.usace.army.mil/greatlakes/hh/outflows/discharge_measurements/detroit_river/ (accessed 1 September 2008).

United States Department of State. “Pro memoria note recording consultations between the United States and Canada on same (April 22, 2003).” *Digest of United States Practice in International Law* (2003): 18. <http://www.state.gov/s/l/2003/44389.htm> (accessed 10 October 2008).

APPENDIX A

TREATY OF GHENT

(“Treaty of Peace and Amity,” William Malloy, comp. *Treaties, Conventions, International Acts, Protocols and Agreements between the United States of America and Other Powers, 1776 – 1909*, 612 - 619.)

His Britannic Majesty and the United States of America desirous of terminating the war which has unhappily subsisted between the two Countries, and of restoring upon principles of perfect reciprocity, Peace, Friendship, and good Understanding between them, have for that purpose appointed their respective Plenipotentiaries, that is to say, His Britannic Majesty on His part has appointed the Right Honourable James Lord Gambier, late Admiral of the White now Admiral of the Red Squadron of His Majesty's Fleet; Henry Goulburn Esquire, a Member of the Imperial Parliament and Under Secretary of State; and William Adams Esquire, Doctor of Civil Laws: And the President of the United States, by and with the advice and consent of the Senate thereof, has appointed John Quincy Adams, James A. Bayard, Henry Clay, Jonathan Russell, and Albert Gallatin, Citizens of the United States; who, after a reciprocal communication of their respective Full Powers, have agreed upon the following Articles.

ARTICLE THE FIRST.

There shall be a firm and universal Peace between His Britannic Majesty and the United States, and between their respective Countries, Territories, Cities, Towns, and People of every degree without exception of places or persons. All hostilities both by sea and land shall cease as soon as this Treaty shall have been ratified by both parties as hereinafter mentioned. All territory, places, and possessions whatsoever taken by either party from the other during the war, or which may be taken after the signing of this Treaty, excepting only the Islands hereinafter mentioned, shall be restored without delay and without causing any destruction or carrying away any of the Artillery or other public property originally captured in the said forts or places, and which shall remain therein

upon the Exchange of the Ratifications of this Treaty, or any Slaves or other private property; And all Archives, Records, Deeds, and Papers, either of a public nature or belonging to private persons, which in the course of the war may have fallen into the hands of the Officers of either party, shall be, as far as may be practicable, forthwith restored and delivered to the proper authorities and persons to whom they respectively belong. Such of the Islands in the Bay of Passamaquoddy as are claimed by both parties shall remain in the possession of the party in whose occupation they may be at the time of the Exchange of the Ratifications of this Treaty until the decision respecting the title to the said Islands shall have been made in conformity with the fourth Article of this Treaty. No disposition made by this Treaty as to such possession of the Islands and territories claimed by both parties shall in any manner whatever be construed to affect the right of either.

ARTICLE THE SECOND.

Immediately after the ratifications of this Treaty by both parties as hereinafter mentioned, orders shall be sent to the Armies, Squadrons, Officers, Subjects, and Citizens of the two Powers to cease from all hostilities: and to prevent all causes of complaint which might arise on account of the prizes which may be taken at sea after the said Ratifications of this Treaty, it is reciprocally agreed that all vessels and effects which may be taken after the space of twelve days from the said Ratifications upon all parts of the Coast of North America from the Latitude of twenty three degrees North to the Latitude of fifty degrees North, and as far Eastward in the Atlantic Ocean as the thirty sixth degree of West Longitude from the Meridian of Greenwich, shall be restored on each side:-that the time shall be thirty days in all other parts of the Atlantic Ocean North of the Equinoctial Line or Equator:-and the same time for the British and Irish Channels, for the Gulf of Mexico, and all parts of the West Indies:-forty days for the North Seas for the Baltic, and for all parts of the Mediterranean-sixty days for the Atlantic Ocean South of the Equator as far as the Latitude of the Cape of Good Hope.-ninety days for every other part of the world South of the Equator, and one hundred and twenty days for all other parts of the world without exception.

ARTICLE THE THIRD.

All Prisoners of war taken on either side as well by land as by sea shall be restored as soon as practicable after the Ratifications of this Treaty as hereinafter mentioned on their paying the debts which they may have contracted during their captivity. The two Contracting Parties respectively engage to discharge in specie the advances which may have been made by the other for the sustenance and maintenance of such prisoners.

ARTICLE THE FOURTH.

Whereas it was stipulated by the second Article in the Treaty of Peace of one thousand seven hundred and eighty three between His Britannic Majesty and the United States of America that the boundary of the United States should comprehend "all Islands within twenty leagues of any part of the shores of the United States and lying between lines to be drawn due East from the points where the aforesaid boundaries between Nova Scotia on the one part and East Florida on the other shall respectively touch the Bay of Fundy and the Atlantic Ocean, excepting such Islands as now are or heretofore have been within the limits of Nova Scotia, and whereas the several Islands in the Bay of Passamaquoddy, which is part of the Bay of Fundy, and the Island of Grand Menan in the said Bay of Fundy, are claimed by the United States as being comprehended within their aforesaid boundaries, which said Islands are claimed as belonging to His Britannic Majesty as having been at the time of and previous to the aforesaid Treaty of one thousand seven hundred and eighty three within the limits of the Province of Nova Scotia: In order therefore finally to decide upon these claims it is agreed that they shall be referred to two Commissioners to be appointed in the following manner: viz: One Commissioner shall be appointed by His Britannic Majesty and one by the President of the United States, by and with the advice and consent of the Senate thereof, and the said two Commissioners so appointed shall be sworn impartially to examine and decide upon the said claims according to such evidence as shall be laid before them on the part of His Britannic Majesty and of the United States respectively. The said Commissioners shall

meet at St Andrews in the Province of New Brunswick, and shall have power to adjourn to such other place or places as they shall think fit. The said Commissioners shall by a declaration or report under their hands and seals decide to which of the two Contracting parties the several Islands aforesaid do respectely [sic] belong in conformity with the true intent of the said Treaty of Peace of one thousand seven hundred and eighty three. And if the said Commissioners shall agree in their decision both parties shall consider such decision as final and conclusive. It is further agreed that in the event of the two Commissioners differing upon all or any of the matters so referred to them, or in the event of both or either of the said Commissioners refusing or declining or wilfully [sic] omitting to act as such, they shall make jointly or separately a report or reports as well to the Government of His Britannic Majesty as to that of the United States, stating in detail the points on which they differ, and the grounds upon which their respective opinions have been formed, or the grounds upon which they or either of them have so refused declined or omitted to act. And His Britannic Majesty and the Government of the United States hereby agree to refer the report or reports of the said Commissioners to some friendly Sovereign or State to be then named for that purpose, and who shall be requested to decide on the differences which may be stated in the said report or reports, or upon the report of one Commissioner together with the grounds upon which the other Commissioner shall have refused, declined or omitted to act as the case may be. And if the Commissioner so refusing, declining, or omitting to act, shall also wilfully [sic] omit to state the grounds upon which he has so done in such manner that the said statement may be referred to such friendly Sovereign or State together with the report of such other Commissioner, then such Sovereign or State shall decide ex parse upon the said report alone. And His Britannic Majesty and the Government of the United States engage to consider the decision of such friendly Sovereign or State to be final and conclusive on all the matters so referred.

ARTICLE THE FIFTH.

Whereas neither that point of the Highlands lying due North from the source of the River St Croix, and designated in the former Treaty of Peace between the two Powers as

the North West Angle of Nova Scotia, nor the North Westernmost head of Connecticut River has yet been ascertained; and whereas that part of the boundary line between the Dominions of the two Powers which extends from the source of the River St Croix directly North to the above mentioned North West Angle of Nova Scotia, thence along the said Highlands which divide those Rivers that empty themselves into the River St Lawrence from those which fall into the Atlantic Ocean to the North Westernmost head of Connecticut River, thence down along the middle of that River to the forty fifth degree of North Latitude, thence by a line due West on said latitude until it strikes the River Iroquois or Cataraguay, has not yet been surveyed: it is agreed that for these several purposes two Commissioners shall be appointed, sworn, and authorized to act exactly in the manner directed with respect to those mentioned in the next preceding Article unless otherwise specified in the present Article. The said Commissioners shall meet at se Andrews in the Province of New Brunswick, and shall have power to adjourn to such other place or places as they shall think fit. The said Commissioners shall have power to ascertain and determine the points above mentioned in conformity with the provisions of the said Treaty of Peace of one thousand seven hundred and eighty three, and shall cause the boundary aforesaid from the source of the River St Croix to the River Iroquois or Cataraguay to be surveyed and marked according to the said provisions. The said Commissioners shall make a map of the said boundary, and annex to it a declaration under their hands and seals certifying it to be the true Map of the said boundary, and particularizing the latitude and longitude of the North West Angle of Nova Scotia, of the North Westernmost head of Connecticut River, and of such other points of the said boundary as they may deem proper. And both parties agree to consider such map and declaration as finally and conclusively fixing the said boundary. And in the event of the said two Commissioners differing, or both, or either of them refusing, declining, or wilfully [sic] omitting to act, such reports, declarations, or statements shall be made by them or either of them, and such reference to a friendly Sovereign or State shall be made in all respects as in the latter part of the fourth Article is contained, and in as full a manner as if the same was herein repeated.

ARTICLE THE SIXTH.

Whereas by the former Treaty of Peace that portion of the boundary of the United States from the point where the fortyfifth [sic] degree of North Latitude strikes the River Iroquois or Cataraquy to the Lake Superior was declared to be "along the middle of said River into Lake Ontario, through the middle of said Lake until it strikes the communication by water between that Lake and Lake Erie, thence along the middle of said communication into Lake Erie, through the middle of said Lake until it arrives at the water communication into the Lake Huron; thence through the middle of said Lake to the water communication between that Lake and Lake Superior:" and whereas doubts have arisen what was the middle of the said River, Lakes, and water communications, and whether certain Islands lying in the same were within the Dominions of His Britannic Majesty or of the United States: In order therefore finally to decide these doubts, they shall be referred to two Commissioners to be appointed, sworn, and authorized to act exactly in the manner directed with respect to those mentioned in the next preceding Article unless otherwise specified in this present Article. The said Commissioners shall meet in the first instance at Albany in the State of New York, and shall have power to adjourn to such other place or places as they shall think fit. The said Commissioners shall by a Report or Declaration under their hands and seals, designate the boundary through the said River, Lakes, and water communications, and decide to which of the two Contracting parties the several Islands lying within the said Rivers, Lakes, and water communications, do respectively belong in conformity with the true intent of the said Treaty of one thousand seven hundred and eighty three. And both parties agree to consider such designation and decision as final and conclusive. And in the event of the said two Commissioners differing or both or either of them refusing, declining, or wilfully [sic] omitting to act, such reports, declarations, or statements shall be made by them or either of them, and such reference to a friendly Sovereign or State shall be made in all respects as in the latter part of the fourth Article is contained, and in as full a manner as if the same was herein repeated.

ARTICLE THE SEVENTH.

It is further agreed that the said two last mentioned Commissioners after they shall have executed the duties assigned to them in the preceding Article, shall be, and they are hereby, authorized upon their oaths impartially to fix and determine according to the true intent of the said Treaty of Peace of one thousand seven hundred and eighty three, that part of the boundary between the dominions of the two Powers, which extends from the water communication between Lake Huron and Lake Superior to the most North Western point of the Lake of the Woods;-to decide to which of the two Parties the several Islands lying in the Lakes, water communications, and Rivers forming the said boundary do respectively belong in conformity with the true intent of the said Treaty of Peace of one thousand seven hundred and eighty three, and to cause such parts of the said boundary as require it to be surveyed and marked. The said Commissioners shall by a Report or declaration under their hands and seals, designate the boundary aforesaid, state their decision on the points thus referred to them, and particularize the Latitude and Longitude of the most North Western point of the Lake of the Woods, and of such other parts of the said boundary as they may deem proper. And both parties agree to consider such designation and decision as final and conclusive. And in the event of the said two Commissioners differing, or both or either of them refusing, declining, or wilfully [sic] omitting to act, such reports, declarations or statements shall be made by them or either of them, and such reference to a friendly Sovereign or State shall be made in all respects as in the latter part of the fourth Article is contained, and in as full a manner as if the same was herein revealed.

ARTICLE THE EIGHTH.

The several Boards of two Commissioners mentioned in the four preceding Articles shall respectively have power to appoint a Secretary, and to employ such Surveyors or other persons as they shall judge necessary. Duplicates of all their respective reports, declarations, statements, and decisions, and of their accounts, and of the Journal of their proceedings shall be delivered by them to the Agents of His Britannic Majesty and to the Agents of the United States, who may be respectively appointed and authorized to

manage the business on behalf of their respective Governments. The said Commissioners shall be respectively paid in such manner as shall be agreed between the two contracting parties, such agreement being to be settled at the time of the Exchange of the Ratifications of this Treaty. And all other expenses attending the said Commissions shall be defrayed equally by the two parties. And in the case of death, sickness, resignation, or necessary absence, the place of every such Commissioner respectively shall be supplied in the same manner as such Commissioner was first appointed; and the new Commissioner shall take the same oath or affirmation and do the same duties. It is further agreed between the two contracting parties that in case any of the Islands mentioned in any of the preceding Articles, which were in the possession of one of the parties prior to the commencement of the present war between the two Countries, should by the decision of any of the Boards of Commissioners aforesaid, or of the Sovereign or State so referred to, as in the four next preceding Articles contained, fall within the dominions of the other party, all grants of land made previous to the commencement of the war by the party having had such possession, shall be as valid as if such Island or Islands had by such decision or decisions been adjudged to be within the dominions of the party having had such possession.

ARTICLE THE NINTH.

The United States of America engage to put an end immediately after the Ratification of the present Treaty to hostilities with all the Tribes or Nations of Indians with whom they may be at war at the time of such Ratification, and forthwith to restore to such Tribes or Nations respectively all the possessions, rights, and privileges which they may have enjoyed or been entitled to in one thousand eight hundred and eleven previous to such hostilities. Provided always that such Tribes or Nations shall agree to desist from all hostilities against the United States of America, their Citizens, and Subjects upon the Ratification of the present Treaty being notified to such Tribes or Nations, and shall so desist accordingly. And His Britannic Majesty engages on his part to put an end immediately after the Ratification of the present Treaty to hostilities with all the Tribes or Nations of Indians with whom He may be at war at the time of such Ratification, and

forthwith to restore to such Tribes or Nations respectively all the possessions, rights, and privileges, which they may have enjoyed or been entitled to in one thousand eight hundred and eleven previous to such hostilities. Provided always that such Tribes or Nations shall agree to desist from all hostilities against His Britannic Majesty and His Subjects upon the Ratification of the present Treaty being notified to such Tribes or Nations, and shall so desist accordingly.

ARTICLE THE TENTH.

Whereas the Traffic in Slaves is irreconcilable with the principles of humanity and Justice, and whereas both His Majesty and the United States are desirous of continuing their efforts to promote its entire abolition, it is hereby agreed that both the contracting parties shall use their best endeavours to accomplish so desirable an object.

ARTICLE THE ELEVENTH.

This Treaty when the same shall have been ratified on both sides without alteration by either of the contracting parties, and the Ratifications mutually exchanged, shall be binding on both parties, and the Ratifications shall be exchanged at Washington in the space of four months from this day or sooner if practicable. In faith whereof, We the respective Plenipotentiaries have signed this Treaty, and have hereunto affixed our Seals.

Done in triplicate at Ghent the twenty fourth day of December one thousand eight hundred and fourteen.

GAMBIER. [Seal]

HENRY GOULBURN [Seal]

WILLIAM ADAMS [Seal]

JOHN QUINCY ADAMS [Seal]

J. A. BAYARD [Seal]

H. CLAY. [Seal]

JON. RUSSELL [Seal]

ALBERT GALLATIN [Seal]

APPENDIX B

SCHOONER SPARS AND SAILS

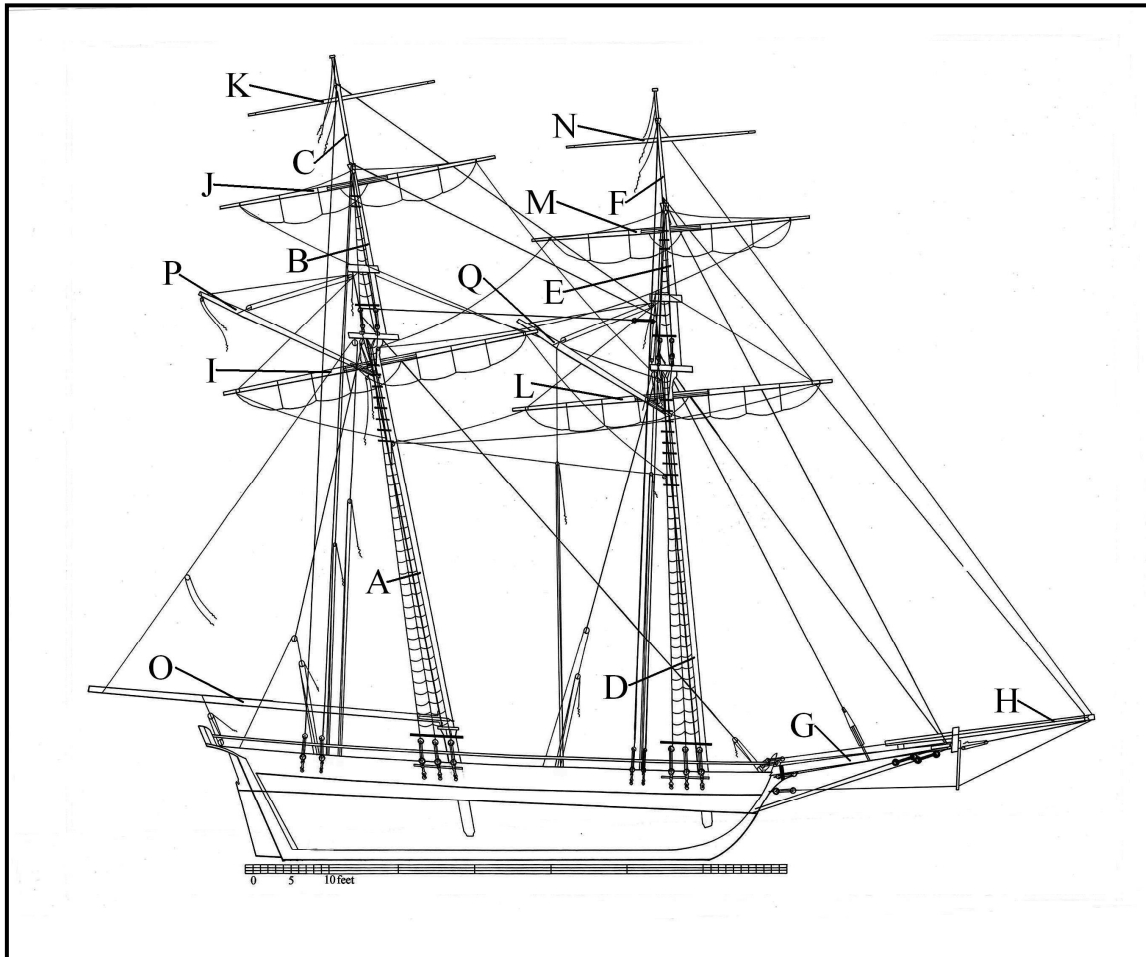

Newash and Tecumseth's Original Schooner Spars

- | | |
|--------------------------|--------------------------|
| A – Main Lower Mast | I – Main Lower Yard |
| B – Main Topmast | J – Main Topsail Yard |
| C – Main Topgallant Pole | K – Main Topgallant Yard |
| D – Fore Lower Mast | L – Fore Lower Yard |
| E – Fore Topmast | M – Fore Topsail Yard |
| F – Fore Topgallant Pole | N – Fore Topgallant Yard |
| G – Bowsprit | O – Mainsail Boom |
| H – Jibboom | P – Mainsail Gaff |
| | Q – Foresail Gaff |

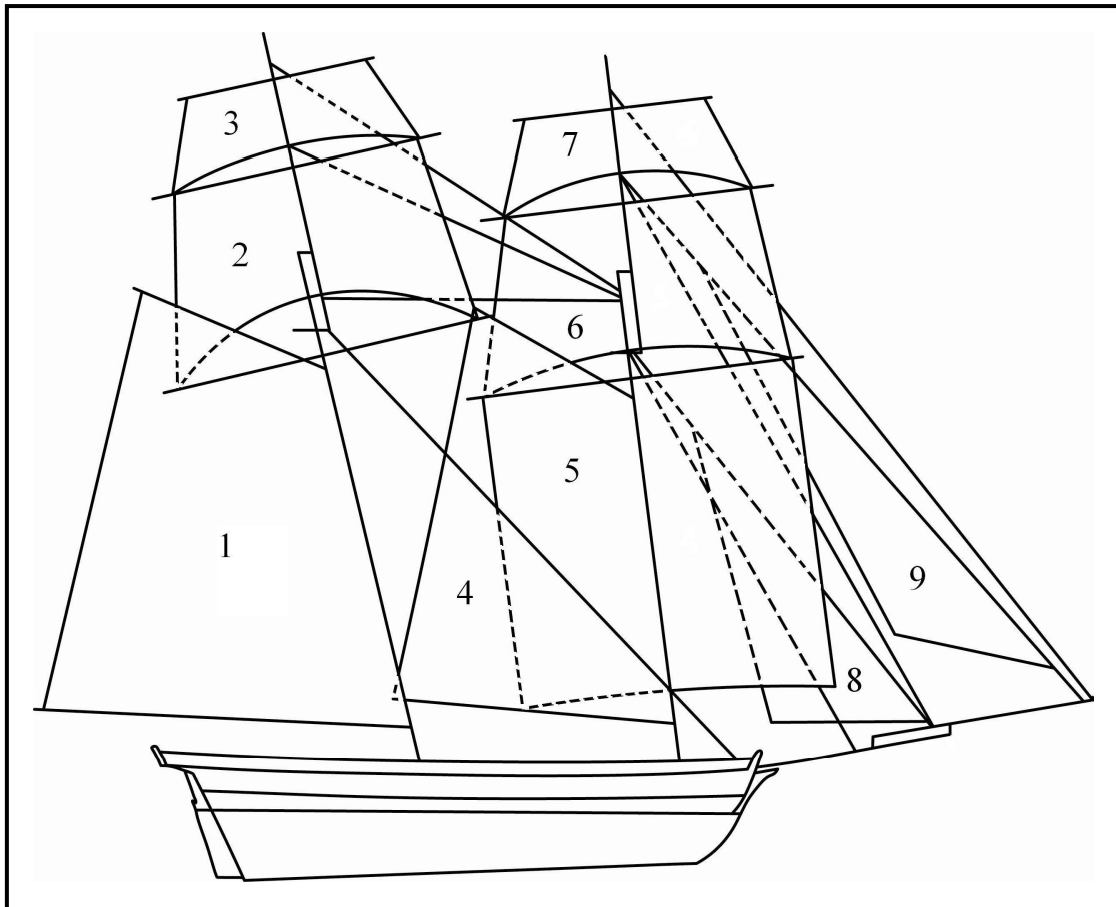

Newash and Tecumseth's Original Schooner Sails

- 1 – Boom Mainsail
- 2 – Main Topsail
- 3 – Main Topgallantsail
- 4 – Gaff Foresail
- 5 – Square Sail
- 6 – Fore Topsail
- 7 – Fore Topgallantsail
- 8 – Standing Jib
- 9 – Flying Jib

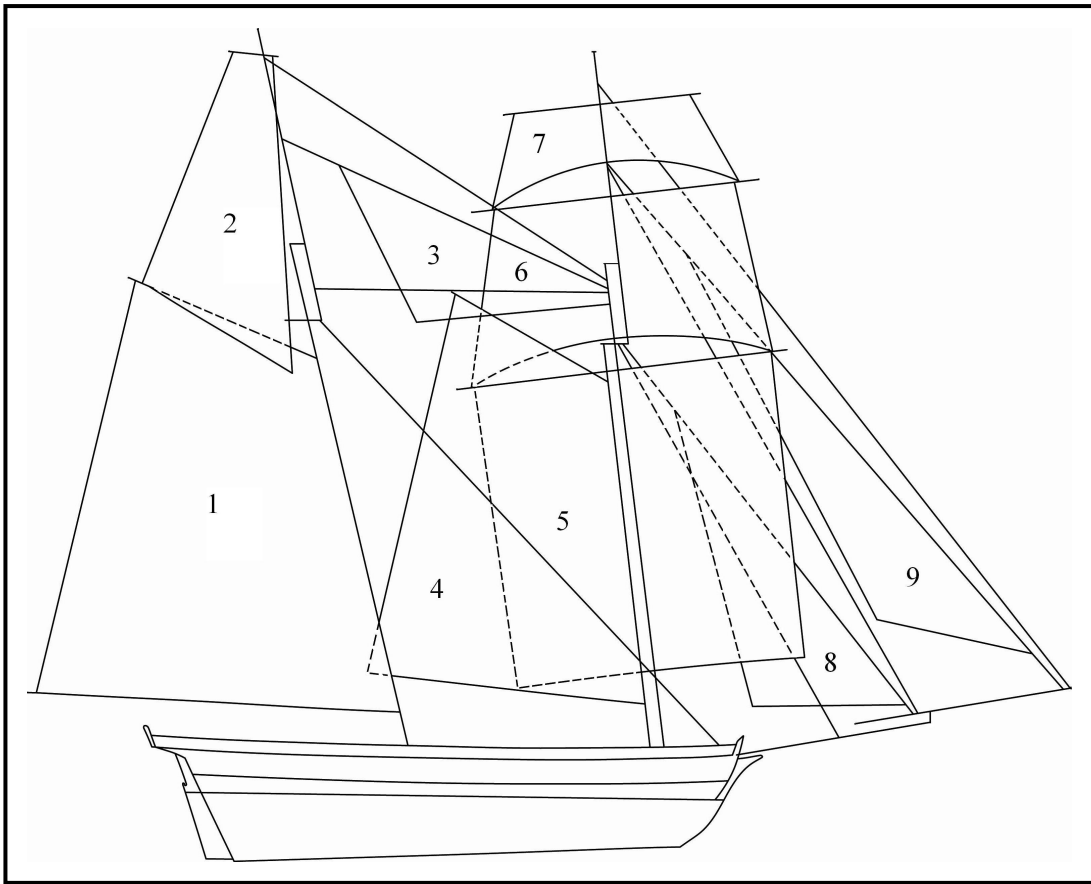

Tecumseth's Schooner II Sails

- 1 – Boom Mainsail
- 2 – Main Gaff Topsail
- 3 – Main Topmast Staysail
- 4 – Gaff Foresail
- 5 – Square Sail
- 6 – Fore Topsail
- 7 – Fore Topgallantsail
- 8 – Standing Jib
- 9 – Flying Jib

APPENDIX C

RUSH-BAGOT AGREEMENT

(“Agreement Effected by Exchange of Notes Concerning Naval Force on the Great Lakes,” Willaim Malloy, comp. *Treaties, Conventions, International Acts, Protocols and Agreements between the United States of America and Other Powers, 1776 – 1909*, 628-630.)

Exchange of Notes Relative to Naval Forces on the American Lakes, signed at Washington April 28 and 29, 1817. Originals in English. Submitted to the Senate April 6, 1818. Resolution of approval and consent April 16, 1818. Proclaimed April 28, 1818. WASHINGTON April 16, 1817

The Undersigned, His Britannick Majesty's Envoy Extraordinary and Minister Plenipotentiary, has the honour to acquaint Mr. Rush, that having laid before His Majesty's Government the correspondence which passed last year between the Secretary of the Department of State and the Undersigned upon the subject of a proposal to reduce the Naval Force of the respective Countries upon the American Lakes, he has received the Commands of His Royal Highness The Prince Regent to acquaint the Government of the United States, that His Royal Highness is willing to accede to the proposition made to the Undersigned by the Secretary of the Department of State in his note of the second of August last.

His Royal Highness, acting in the name and on the behalf of His Majesty, agrees, that the Naval Force to be maintained upon the American Lakes by His Majesty and the Government of the United States shall henceforth be confined to the following Vessels on each side-that is:

On Lake Ontario to one Vessel not exceeding one hundred Tons burthen and armed with one eighteen pound cannon.

On the Upper Lakes to two Vessels not exceeding like burthen each and armed with like force.

On the Waters of Lake Champlain to one Vessel not exceeding like burthen and armed with like force.

And His Royal Highness agrees, that all other armed Vessels on these Lakes shall be forthwith dismantled, and that no other Vessels of War shall be there built or armed.

His Royal Highness further agrees, that if either Party should hereafter be desirous of annulling this Stipulation, and should give notice to that effect to the other Party, it shall cease to be binding after the expiration of six months from the date of such notice.

The Undersigned has it in command from His Royal Highness the Prince Regent to acquaint the American Government, that His Royal Highness has issued Orders to His Majestys Officers on the Lakes directing, that the Naval Force so to be limited shall be restricted to such Services as will in no respect interfere with the proper duties of the armed Vessels of the other Party.

The Undersigned has the honour to renew to Mr. Rush the assurances of his highest consideration.

CHARLES BAGOT

DEPARTMENT OF STATE,

April 29. 1817.

The Undersigned, Acting Secretary of State, has the honor to acknowledge the receipt of Mr. Bagot's note of the 28th of this month, informing him that, having laid before the Government of His Britannick Majesty, the correspondence which passed last year between the Secretary of State and himself upon the subject of a proposal to reduce the naval force of the two countries upon the American Lakes, he had received the commands of His Royal Highness The Prince Regent to inform this Government that His Royal Highness was willing to accede to the proposition made by the Secretary of State in his note of the second of August last.

The Undersigned has the honor to express to Mr. Bagot the satisfaction which The President feels at His Royal Highness The Prince Regent's having acceded to the proposition of this government as contained in the note alluded to. And in further answer to Mr. Bagot's note, the Undersigned, by direction of The President, has the honor to state, that this Government, cherishing the same sentiments expressed in the note of the second of August, agrees, that the naval force to be maintained upon the Lakes by the United-States and Great Britain shall, henceforth, be confined to the following vessels on each side,-that is:

On Lake Ontario to one vessel not exceeding One Hundred Tons burden, and armed with one eighteen-pound cannon. On the Upper Lakes to two vessels not exceeding the like burden each, and armed with like force, and on the waters of Lake Champlain to one vessel not exceeding like burden and armed with like force.

And it agrees, that all other armed vessels on these Lakes shall be forthwith dismantled, and that no other vessels of war shall be there built or armed. And it further agrees, that if either party should hereafter be desirous of annulling this stipulation and should give notice to that effect to the other party, it shall cease to be binding after the expiration of six months from the date of such notice.

The Undersigned is also directed by The President to state, that proper orders will be forthwith issued by this Government to restrict the naval force thus limited to such services as will in no respect interfere with the proper duties of the armed vessels of the other party.

The Undersigned eagerly avails himself of this opportunity to tender to Mr. Bagot the assurances of his distinguished consideration and respect.

RICHARD RUSH

APPENDIX D

TABLE OF COEFFICIENTS FOR SELECT VESSELS, 1800 – 1832, FROM HOWARD I. CHAPELLE'S *THE SEARCH FOR SPEED UNDER SAIL*, PAGES 404 – 406.

Name	Rig	L.W.L.	Displ't, in Long Tons	Block Coeff't	Midship Coeff't	Prismatic Coeff't	Camber- Length Ratio	Displ't-Length Ratio	Date
<i>La Vengeance</i>	Ship	105 feet 0 inches [32.31 m]	330.40	.34	.61	.56	10.80	259.00	1800
<i>La Superieure</i>	Schooner	80 feet 0 inches [24.62 m]	160.60	.39	.62	.63	12.90	308.00	1801
<i>Numa</i>	Brig	89 feet 6 inches [27.54 m]	189.00	.42	.64	.64	14.20	290.00	1801
Bermuda Water Tanks	3-masted Schooner	68 feet 4 inches [19.79 m]	136.40	.48	.72	.67	10.80	434.00	1804
Bergh's Ship	Ship	75 feet 10.5 inches [23.35 m]	330.20	.59	.86	.64	6.80	752.00	1804
<i>Revenge</i>	3-masted Schooner	74 feet 0 inches [22.77 m]	109.20	.39	.60	.65	13.20	269.00	1805
Steer's Design	Schooner	82 feet 3 inches [25.31 m]	176.30	.36	.60	.59	10.70	319.00	1805
Canton Yacht	Schooner	46 feet 2 inches [14.21 m]	22.80	.32	.62	.68	15.00	234.00	1805 – 8
<i>Nimble</i>	Schooner	53 feet 0 inches [16.31 m]	34.60	.37	.59	.63	17.30	232.00	1806
<i>Nonpareil</i>	Schooner	82 feet 6 inches [25.38 m]	177.70	.32	.59	.59	10.70	311.00	1807
<i>Dominica</i>	Schooner	84 feet 6 inches [26.00 m]	141.80	.38	.59	.64	14.70	231.00	1809
<i>Experiment</i>	Schooner	71 feet 4 inches [21.95 m]	96.20	.31	.51	.62	14.70	213.00	1810

Name	Rig	L.W.L.	Displ't in Long Tons	Block Coeff't	Midship Coeff't	Prismatic Coeff't	Camber-Length Ratio	Displ't-Length Ratio	Date
<i>Fly</i>	Schooner	76 feet 8 inches [23.59 m]	142.40	.31	.60	.65	12.60	312.00	1811
<i>Hannibal</i>	Ship	129 feet 10 inches [39.95 m]	934.60	.48	.68	.70	11.10	425.00	1811
<i>Lynx</i>	Schooner	88 feet 0 inches [27.08 m]	191.30	.37	.63	.59	11.70	288.00	1812
<i>William Bayard</i>	Schooner	91 feet 8 inches [28.21 m]	205.90	.39	.61	.64	14.10	265.00	1812
<i>Grecian</i>	Schooner	89 feet 0 inches [27.38 m]	216.40	.35	.54	.65	13.20	307.00	1812
<i>Zebra</i>	Schooner	98 feet 5 inches [30.28 m]	247.50	.40	.59	.67	15.60	261.00	1812
<i>Transfer</i>	Schooner	90 feet 0 inches [27.69 m]	176.00	.36	.60	.61	14.90	241.00	1812
<i>Neufchatel</i>	Hermaphrodite Schooner	107 feet 5 inches [33.05 m]	253.00	.39	.64	.62	17.00	204.00	1812
<i>Achilles</i>	Schooner	62 feet 0 inches [19.08 m]	64.40	.38	.63	.64	14.50	273.00	1812
<i>Snap Dragon</i>	Schooner	84 feet 10 inches [25.86 m]	157.70	.34	.56	.62	15.90	257.00	1812
116-foot [35.69 m] Schooner	Schooner	109 feet 10 inches [33.79 m]	411.50	.43	.67	.62	10.20	309.00	1812 – 14
<i>Dash</i>	Schooner-Brigantine	99 feet 7 inches [30.64 m]	220.50	.38	.60	.63	15.10	224.00	1813
<i>Spark</i>	U.S.N. Brig	96 feet 11 inches [29.59 m]	293.60	.42	.63	.66	13.00	321.00	1813
<i>Reindeer</i>	Hermaphrodite Schooner	116 feet 5 inches [35.82 m]	580.00	.48	.72	.68	10.90	366.00	1814

Name	Rig	L.W.L.	Displ't in Long Tons	Block Coeff't	Midship Coeff't	Prismatic Coeff't	Camber-Length Ratio	Displ't-Length Ratio	Date
105-foot [32.31 m] Schooner	Schooner	99 feet 2 inches [30.51 m]	267.80	.38	.61	.63	12.80	276.00	1814
<i>James Monroe</i>	Brigantine	63 feet 7 inches [19.56 m]	172.00	.62	.72	.85	10.20	672.00	1815
<i>Slaver</i>	Brig	85 feet 6 inches [26.31 m]	261.80	.39	.62	.65	9.80	417.00	1820 – 30
<i>Bolivar</i>	Ship	119 feet 3 inches [36.69 m]	363.00	.32	.55	.63	15.30	210.00	1822
<i>Lafayette</i>	Schooner	57 feet 10 inches [17.79 m]	54.00	.35	.56	.63	13.90	529.00	1824
Flannigan's Design	Brigantine	84 feet 10.5 inches [26.12 m]	211.00	.53	.79	.68	12.00	345.00	1825 – 30
<i>Brothers</i>	Schooner	66 feet 0 inches [20.31 m]	53.60	.30	.53	.56	15.50	186.00	1826
<i>Kensington</i>	Ship	165 feet 2 inches [50.36 m]	1612.70	.76	.70	.67	11.50	357.00	1828
Keel Packet Sloop	Sloop	61 feet 3 inches [18.85 m]	87.50	.32	.53	.61	13.40	379.00	1830 – 40
<i>Isabella</i>	Schooner	75 feet 4 inches [23.18 m]	109.00	.47	.70	.67	13.90	254.00	1830
Merchant Schooner	Schooner	74 feet 5 inches [22.90 m]	112.80	.45	.64	.65	11.20	273.00	1830
<i>Theresa Secunda</i>	Schooner	84 feet 6 inches [25.76 m]	144.10	.38	.61	.62	11.40	238.00	1831
<i>Ann McKim</i>	Ship	138 feet 6 inches [42.62 m]	648.60	.40	.63	.65	15.60	438.00	1832
<i>Tecumseth – Newash</i>	Schooner-Brigantine	66 feet 6 inches [20.46 m]	116.26	.40	.68	.66	11.74	445.23	1815

APPENDIX E

“AN ACCOUNT OF RIGGING AND SAILS BELONGING TO HIS MAJESTY’S
SCHOONER *NEWASH*”

(Thomas Bushby, “An Account of Rigging and Sails Belonging to His Majesty’s Schooner *Newash*,” LAC, Record Group 8, Series III, Volume 5.)

For What Use	Species	Quantity
Anchors Best Bower	8 cwt. 2 qrs. 0 lbs. [952 lbs or 432 kg]	One
Anchors Small Bower	7 cwt. 0 qrs. 0 lbs. [784 lbs or 356 kg]	One
[Cordage]		
[For What Use]	[Size]	[Length]
Cablets	7 ½ inch [19.05 cm]	Two
Cablets	4 inch [10.16 cm]	One
Cablets	3 inch [7.62 cm]	One
Bowsprit Shrouds	4 ½ inch [11.43 cm]	Six fathoms
Bobstay	5 ½ inch [13.97 cm]	Six fathoms
Jibboom Guys	2 ½ inch [6.35 cm]	Twenty-four fathoms
Martingale Stays	2 ½ inch [6.35 cm]	Thirty fathoms
Flying Jib Stay	3 inch [7.62 cm]	Twenty-four fathoms
Jib Hallyards	2 inch [5.08 cm]	Sixty-two fathoms
Jib Sheets	2 inch [5.08 cm]	Eighteen fathoms
Jib Downhauller	1 ½ inch [3.81 cm]	Twenty-two fathoms
Flying Jib Hallyards	2 inch [5.08 cm]	Fifty fathoms
Flying Jib Sheets	2 inch [5.08 cm]	Twenty-five fathoms
Flying Jib Downhauller	1 inch [2.54 cm]	Forty fathoms
Horses for Jibboom	2 ½ inch [6.35 cm]	Twelve fathoms
Fore Shrouds	5 inch [12.70 cm]	Sixty fathoms
Fore Mast Head Pendants	5 inch [12.70 cm]	Eight fathoms
Fore Runners	4 inch [10.16 cm]	Twenty fathoms
Fore Tackles	2 inch [5.08 cm]	Fifty fathoms
Fore Yard Lifts	2 inch [5.08 cm]	Twenty-four fathoms
Fore Yard Trusses	1 ½ inch [3.81 cm]	Eighteen fathoms
Fore Yard Horses	2 inch [5.08 cm]	Nine fathoms
Fore Yard Slings	6 inch [15.24 cm]	Three fathoms
Fore [Gaff] Throat Hallyards	2 ½ inch [6.35 cm]	Forty fathoms
Fore [Gaff] Peak Hallyards	2 ½ inch [6.35 cm]	Thirty-six fathoms
Fore [Gaff] Vangs	2 ½ inch [6.35 cm]	Ten fathoms
Fore [Gaff] Vang Falls	1 ½ inch [3.81 cm]	Twenty fathoms
Fore Peak Brails	1 inch [2.54 cm]	Thirty-six fathoms
Fore Throat Brails	1 ½ inch [3.81 cm]	Thirty-eight fathoms
Fore Foot Brails	1 ½ inch [3.81 cm]	Thirty-four fathoms

[For What Use]	[Size]	[Length]
Fore Sheets	2 ½ inch [6.35 cm]	Thirty fathoms
Fore Topmast Shrouds	3 inch [7.62 cm]	Twenty-two fathoms
Fore Topmast Stay	3 ½ inch [8.89 cm]	Nineteen fathoms
Fore Topmast Backstays	3 inch [7.62 cm]	Thirty-two fathoms
Fore Topsail Hallyards	2 inch [5.08 cm]	Forty-two fathoms
Fore Topsail Sheets	2 ½ inch [6.35 cm]	Forty-four fathoms
Fore Topsail Cluelines	1 ½ inch [3.81 cm]	Forty fathoms
Fore Topsail Bowlines	1 ½ inch [3.81 cm]	Fifty-four fathoms
Fore Topsail Horses	2 inch [5.08 cm]	Six fathoms
Fore Topsail Lifts	2 ½ inch [6.35 cm]	Twenty-eight fathoms
Fore Topsail Braces	2 ½ inch [6.35 cm]	Ninety fathoms
Fore Topgallant Stay	2 inch [5.08 cm]	Thirty-four fathoms
Fore Topgallant Hallyards	2 inch [5.08 cm]	Thirty-six fathoms
Fore Topgallant Sheets	1 inch [2.54 cm]	Twenty-five fathoms
Fore Topgallant Downhauller	1 inch [2.54 cm]	Twenty fathoms
To Signal Hallyards	¾ inch [1.91 cm]	Thirty-six fathoms
Square Sail Hallyards	2 inch [5.08 cm]	Ninety fathoms
Square Sail Sheets	2 inch [5.08 cm]	Twenty fathoms
Main Shrouds	5 inch [12.70 cm]	Sixty fathoms
Main Mast Head Pendants	5 inch [12.70 cm]	Sixty fathoms
Main Mast Head Stay	4 ½ inch [11.43 cm]	Seven fathoms
Main Deck Stay	6 ½ inch [16.51 cm]	Eleven fathoms
Main Deck Stay	5 inch [12.70 cm]	Eleven fathoms
Main Runners	4 inch [10.16 cm]	Twenty fathoms
Main Tackles	2 inch [5.08 cm]	Fifty fathoms
Main Gaff Throat Hallyard	2 ½ inch [6.35 cm]	Forty fathoms
Main Gaff Peak Hallyard	2 ½ inch [6.35 cm]	Forty-two fathoms
Main Gaff Throat Downhaul	1 ½ inch [3.81 cm]	Fourteen fathoms
Main Gaff Peak Downhaul	1 ½ inch [3.81 cm]	Forty fathoms
Main Boom Sheet	2 ½ inch [6.35 cm]	Twenty fathoms
Main Boom Topping Lift	4 inch [10.16 cm]	Twenty-eight fathoms
Main Boom Topping Lift Falls	2 inch [5.08 cm]	Sixty-four fathoms
Lazy Guy	4 inch [10.16 cm]	Five fathoms
Tackle for Lazy Guy	2 inch [5.08 cm]	Twelve fathoms
Main Reef Tackle	1 ½ inch [3.81 cm]	Twenty-five fathoms
Main Reef Pendants	2 ½ inch [6.35 cm]	Ten fathoms
Main Topmast Shrouds	3 inch [7.62 cm]	Twenty fathoms
Main Topmast Stay	3 inch [7.62 cm]	Ten fathoms
Main Topmast Backstays	3 inch [7.62 cm]	Thirty-two fathoms
Signal Hallyards	¾ inch [1.91 cm]	Forty fathoms
Gaff Topsail Hallyards	2 ½ inch [6.35 cm]	Forty fathoms
Gaff Topsail Sheets	2 ½ inch [6.35 cm]	Forty fathoms
Gaff Topsail Tacks	2 ½ inch [6.35 cm]	Twenty-five fathoms
Gaff Topsail Downhauller	2 inch [5.08 cm]	Thirty fathoms
Cat Falls	2 ½ inch [6.35 cm]	Ten fathoms
Blocks		
[For What Use]	Quality	Number
Cat Block	Double 12 inch [30.48 cm]	Two

[For What Use]	[Quality]	[Number]
Fore Top[sail] Bowline	Single 6 inch [15.24 cm]	Two
Flying Jib Downhauller and Hallyard	Single 6 inch [15.24 cm]	Two
Standing Jib Downhauller and Hallyard	Single 6 inch [15.24 cm]	Three
Standing Jib Sheets	Single 8 inch [20.36 cm]	Two
Flying Jib Stay	Single 6 inch [15.24 cm]	Five
Fore Brace	Single 6 inch [15.24 cm]	Two
Fore Lift	Single 6 inch [15.24 cm]	Two
Fore Topsail Sheet	Single 9 inch [22.86 cm]	Two
Fore Topsail Hallyard	Single 6 inch [15.24 cm]	Three
Fore Lift	Double 8 inch [20.36 cm]	Two
Peak Hallyards	Double 9 inch [22.86 cm]	One
Peak Hallyards	Single 9 inch [22.86 cm]	One
Throat Hallyards	Double 9 inch [22.86 cm]	One
Throat Hallyards	Single 9 inch [22.86 cm]	One
Topsail Hallyard and Clueline	Double 6 inch [15.24 cm]	Three
Square Sail Hallyard	Single 6 inch [15.24 cm]	One
Fore Runner and Tackle	Single 9 inch [22.86 cm]	Four
Fore Runner and Tackle	Double 9 inch [22.86 cm]	Two
Brail Blocks	Single 6 inch [15.24 cm]	Eight
Brail Blocks	Double 6 inch [15.24 cm]	One
Fore Sheet	Single 9 inch [22.86 cm]	Two
Fore Vangs	Single 6 inch [15.24 cm]	Four
Main Stay	Double 9 inch [22.86 cm]	Four
Main Runners and Tackles	Single 9 inch [22.86 cm]	Four
Main Runners and Tackles	Double 9 inch [22.86 cm]	Two
Boom Topping Lift	Single 10 inch [25.40 cm]	Two
Boom Topping Lift Falls	Double 8 inch [20.36 cm]	Two
Boom Topping Lift Falls	Single 8 inch [20.36 cm]	Two
Throat Hallyard	Double 8 inch [20.36 cm]	One
Throat Hallyard	Single 8 inch [20.36 cm]	One
Peak Hallyard	Double 8 inch [20.36 cm]	One
Peak Hallyard	Single 8 inch [20.36 cm]	One
Throat Downhaul	Single 6 inch [15.24 cm]	One
Peak Downhaul	Double 6 inch [15.24 cm]	One
Boom Sheets	Double 9 inch [22.86 cm]	Two
Lazy Guy	Double 8 inch [20.36 cm]	One
Lazy Guy	Single 8 inch [20.36 cm]	One
Reef Tackle Fall	Double 6 inch [15.24 cm]	One
Reef Tackle Fall	Single 6 inch [15.24 cm]	One
Gaff Topsail Hallyard	Single 8 inch [20.36 cm]	One
Gaff Topsail Sheet	Single 8 inch [20.36 cm]	Two
Gaff Topsail Downhauller	Single 6 inch [15.24 cm]	One
Sails		
Flying Jib		One
Standing Jib		One
Gaff Foresail		One

[Sails]		
Square Sail		One
Fore Topsail		One
Fore Topgallantsail		One
Boom Mainsail		One
Main Topsail		One – To be converted into a
Main Topgallantsail		One – Gaff Topsail
Wanting to Complete for Six Months		
Quality	Species	Quantity
Rope	4 ½ inch [11.43 cm]	Thirty fathoms
Rope	3 ½ inch [8.89 cm]	One Coil
Rope	3 inch [7.62 cm]	One Coil
Rope	2 ½ inch [6.35 cm]	Three Coils
Rope	2 inch [5.08 cm]	Two Coils
Rope	1 ½ inch [3.81 cm]	Two Coils
Rope	1 inch [2.54 cm]	Two Coils
Rope	¾ inch [1.91 cm]	One Coil
Tallow		Fifty-six lbs.
Junk		Five cwt.
Lead Lines	Deepsea	One
Hand Lines		Four
Log Lines		Eight
Canvas	No. 5	One Bolt
Canvas	No. 6	One Bolt
Canvas	No. 7	One Bolt
Canvas	No. 8	One Bolt
Twine and Needles in Proportion		
Glass	½ hour	One
Glass	½ minute	One
Glass	¼ minute	One
Hooks Boat		Five
Paint	White	Thirty lbs.
Paint	Black	Thirty lbs.
Paint	Yellow	Ten lbs.
Oil Lynseed		Twelve Gallons
Oil Dryar		Two lbs.
Spirits	Turpentine	Four Gallons
Varnish	Black	Ten Gallons
Thimbles of Sizes		Fifty
Tackle Hooks		Thirty
Blocks	Double 5 inch [12.70 cm]	Two
Blocks	Double 6 inch [15.24 cm]	Twelve
Blocks	Double 7 inch [17.78 cm]	Six
Blocks	Double 8 inch [20.36 cm]	Ten
Blocks	Double 9 inch [22.86 cm]	Six
Blocks	Double 10 inch [25.40 cm]	Two
Blocks Cat	Double 12 inch [30.48 cm]	Two
Blocks	Single 6 inch [15.24 cm]	Twenty

[Quality]	[Species]	[Quantity]
Blocks	Single 7 inch [17.78 cm]	Twelve
Blocks	Single 8 inch [20.36 cm]	Ten
Blocks	Single 9 inch [22.86 cm]	Six
Blocks	Single 10 inch [25.40 cm]	Four
Blocks	Single 11 inch [27.94 cm]	Six
Old Canvas		Fifty yards
Hammocks		Twenty-five

APPENDIX F

SPAR LENGTH PROPORTIONS FROM HOWARD I. CHAPELLE'S *THE
BALTIMORE CLIPPER*, PAGE 160.

Main mast, hounded	Extreme Breadth x 2.60 – 2.80
Fore Mast, hounded	Main Mast x 0.90 – 0.97
Topmasts, hounded	Extreme Breadth x 0.83 – 1.00
Heads of Lower Masts	Topmasts x 0.30 – 0.40
Pole heads of Topmasts	Hounded length x 0.50
Bowsprit	LWL x ~0.33
Jibboom	LWL x ~0.40
Main Boom	LWL x 0.66 – 0.75
Main Gaff	Main Boom x 0.48 – 0.53
Fore Gaff	Main Gaff x 0.73 – 1.00
Fore Yard	LWL x 0.48 – 0.57
Fore Topsail Yard	Fore Yard x 0.70 – 0.75
Fore Topgallant Yard	Fore Yard x 0.42 – 0.48
Main Yards nearly equal to fore stack	
Square Sail Boom	LWL x 0.37 – 0.44

APPENDIX G

E-MAIL COMMUNICATION FROM CAPTAIN WALTER RYBKA ON THE USE OF
HEARTS AND DEADEYES

Hello to both LeeAnne and Kevin,

I have never found a definitive answer as to why hearts are used on stays and deadeyes on shrouds. However, based on operational experience I can offer a supposition:

In tuning the rig it is more of a challenge to get the stays tight enough, and to keep them that way. You only have one or two stays leading forward per mast section, but four to seven shrouds. Furthermore, the greatest strain on the rig probably came when staying (tacking) into a head sea. Slack stays would not only allow the headsails to sag off to leeward (destroying windward ability) but would also permit the masts to whip fore and aft from the pounding of a sea on the bow, as well as from the sudden shift of square sails full to aback during maneuvers. So keeping the stays taut was more important than the shrouds.

Deadeyes to my knowledge never had more than three holes, and rove off from one side to the other. This limited them to six parts of line, which was the most practical due to cumulative friction when hauling on only one end of the lanyard. In fact the hard part of setting up deadeyes is not having one of them rotate due to the asymmetrical [sic] strain. The deadeye needs to be tightly seized into the shroud, and the lanyard needs to be well lubricated and attention payed [sic] to all parts moving as the lanyard is rove taut. A deadeye is inherently stronger than a heart, offering so much more wood to rope ratio, but the cost is in the friction of that much bearing surface.

Hearts were typically scored for four to even five parts. Smaller ones had one end of the lanyard spliced and hauled on the other, and were really no better than a deadeye. But it was also possible to middle the lanyard, pass it over a center score in one heart, and then

reeve each end in opposite directions. The result would be two hauling parts on the one lanyard which could be hove taut either together or separately. By dividing the pull this way you could have more parts rove, but less cumulative friction than would occur with one bitter end secured.

So to sum up, I think hearts were used where there was room for a bulkier arrangement combined with the need for more tension than could be achieved with a deadeye.

What I have never figured out is why the idea of a double ended lanyard wasn't applied to deadeyes. If you used a three hole deadeye for the upper, and a four hole for the lower, and began reeving from the center hole of the upper, each end going in opposite directions through the center holes of the lower, you would end up with eight parts of line instead of six, but no one part had to move through more than three holes. There has to be a catch, the idea must have been tried and discarded. Or perhaps several centuries too late I have stumbled onto an improved version of a stone ax.

Best wishes, Walter

VITA

LeeAnne Elizabeth Gordon received a Bachelor of Arts degree in English from Auburn University in 2001. After graduation, Miss Gordon spent several years sailing in traditionally-rigged tall ships. In her travels, she has sailed on all five Great Lakes as well as the east and west coasts of the United States and Canada and the Caribbean. She entered the Nautical Archaeology Program in the Anthropology Department at Texas A&M University in August 2006 and received her Master of Arts degree in May 2009. Miss Gordon's research interests include the Great Lakes, the War of 1812 and sail training.

Miss Gordon can be reached at 1665 Davison Road, Harborcreek, PA 16421. Her e-mail address is L7Annie@hotmail.com.