

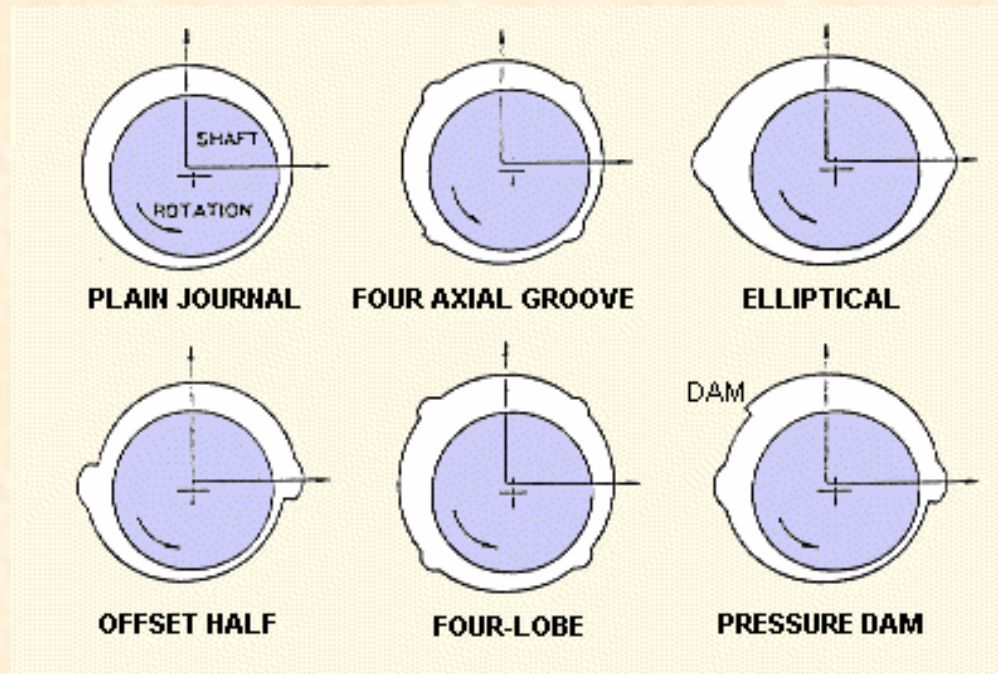

Thermal analysis of finite length journal bearings including fluid inertia



Luis San Andres
Mast-Childs Professor
Sept 2009

NOTES 7

THERMAL ANALYSIS OF FINITE LENGTH JOURNAL BEARINGS INCLUDING FLUID INERTIA EFFECTS

Notes 4 and 5 presented the derivation of the pressure field, load capacity and dynamic force coefficients in a short length cylindrical journal bearing. Notes 7 present an analysis for the prediction, using numerical methods, of the static load capacity and dynamic force coefficients in finite-length journal bearings. Practical bearing geometries include lubricant feeding arrangements (grooves and holes), multiple pads with mechanical preloads to enhance their load capacity and stability. The analysis includes the evaluation of the film mean temperature field from an energy transport equation. The film temperature affects the viscosity of the lubricant within the fluid flow region. In addition, the analysis includes temporal fluid inertia effects modifying the classical Reynolds equation; and hence, the model predicts not only stiffness and damping force coefficients but also added mass coefficients. As recent test data shows, fluid inertia effects cannot longer be ignored in journal bearing forced performance, static or dynamic.

Introduction

Analysis of the dynamic performance of rotors supported on fluid film bearings relies not just on the rotor structural (mass and elastic) properties but also on the accurate evaluation of the static and dynamic forced performance characteristics of the bearing supports. A rotordynamic analysis delivers synchronous response to imbalance and stability results in accordance with API requirements, to demonstrate certain performance characteristics ; and on occasion, to reproduce peculiar field phenomena and to troubleshoot malfunctions or limitations of the operating system.

Mineral-oil lubricated bearings support most commercial machinery that operate at low to moderately high rotational shaft speeds. The bearings carry heavy static loads, mainly a fraction of the rotor weight. The lubricant, supplied from an external reservoir, fills the small clearance separating the shaft (journal) from the bearing. Shaft rotation drags the lubricant through the bearing film lands to form the hydrodynamic wedge that generates the hydrodynamic fluid film pressure that, acting on the journal, is able to support or carry the applied static load. The mineral oil lubricant, generally of large viscosity, increases its temperature as it carries away the

mechanical energy dissipated into heat. Hence, the material viscosity of the lubricant, a strong function of temperature, does not remain constant within the film flow region in the bearing.

Importantly enough, the conditions of low speed (Ω), small clearance (c), and large viscosity (μ/ρ) determine a laminar flow condition in the bearing, i.e. operation with small Reynolds numbers $Re < 1,000$ ($Re = \rho\Omega Rc/\mu$). Hence, Reynolds equation of Classical Lubrication is valid for prediction of the equilibrium hydrodynamic film pressure in the bearing. The prediction of the thermal energy transport in a thin film bearing is more difficult since there is a significant temperature along and across the film, i.e. a three-dimensional phenomenon. Most importantly, the thermal energy exchange does not just involve the mechanical energy generated by shear and its advection by the lubricant flow but also must account for the heat conduction into or from the shaft and bearing cartridge.

A comprehensive 3-D thermohydrodynamic analysis for prediction of performance in finite length journal bearings is out of the scope of these lecture notes. The interested reader should refer to relevant work in the archival literature [1,2] for further details. However, note that most fluid film bearing designers and bearing manufacturers rarely rely on cumbersome and computationally expensive analysis tools; in particular when these require of boundary conditions that are operating system dependent (not general). More than often, engineers prefer to obtain model results that are in agreement with published test data and go along with their vast practical experience.

Analysis

Figures 1 and 2 depict the geometry of typical cylindrical journal bearings comprised of a journal rotating with angular speed (Ω) and a bearing with one or more arcuate pads. A film of lubricant fills the gap between the bearing and its journal. Journal center displacements (e_x, e_y) refer to the (X, Y) inertial coordinate system. The angle Θ , whose origin is at the $-X$ axis, aids to describe the film geometry. The graphs show the relevant nomenclature for analysis.

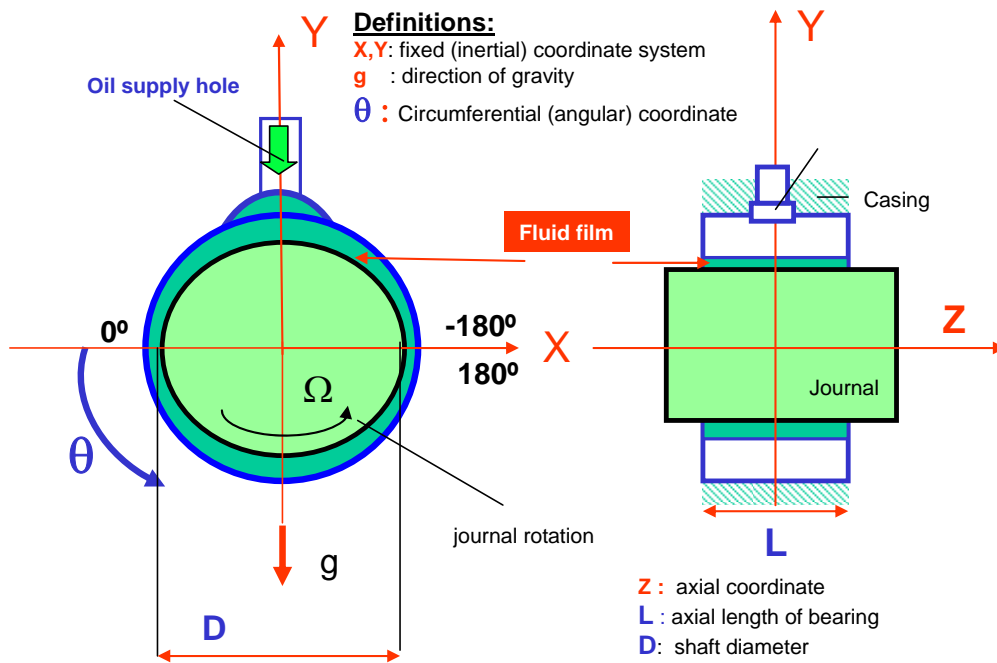

Figure 1. Geometry of a cylindrical bearing pad with feed hole (not to scale)

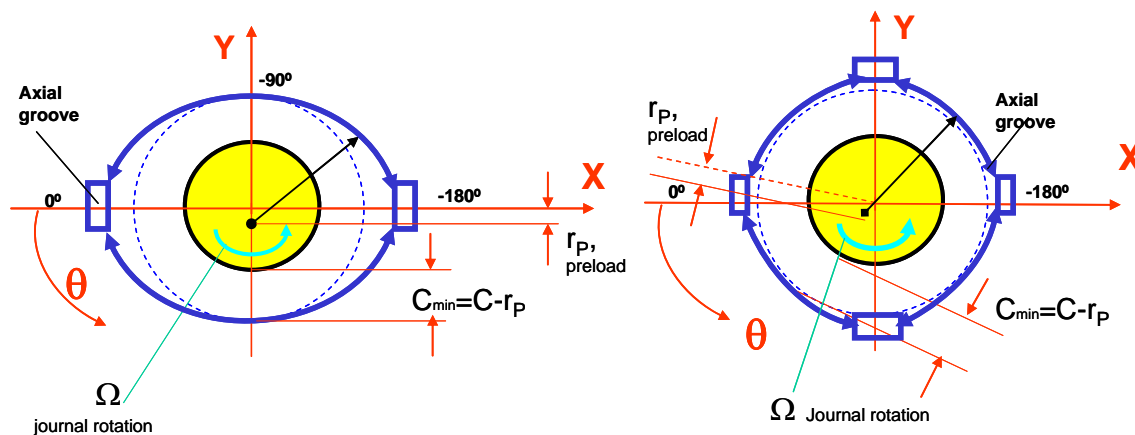

Figure 2. Geometry of elliptical (two groove) and four-pad cylindrical bearings (not to scale)

Figure 3 shows a typical bearing pad with radial clearance (c) and preload (r_p) at angle Θ_p . Θ_l and Θ_t denote the leading edge and trailing edges of the pad, respectively. Within the flow region $\{ \Theta_l \leq \Theta \leq \Theta_t, 0 < z < L \}$, the film thickness (h) is

$$h = c - r_p \cos(\Theta - \Theta_p) + e_{X(t)} \cos \Theta + e_{Y(t)} \sin \Theta \quad (1)$$

where $(e_X, e_Y)_{(t)}$ are the journal center eccentricity components along the (X, Y) directions.

Nomenclature

- C**: pad clearance
- C_m**: assembled clearance
- e**: journal eccentricity
- r_p = C - C_m**: preload,
- r_p = 0**, cylindrical pad
- r_p = c**, journal and pad contact

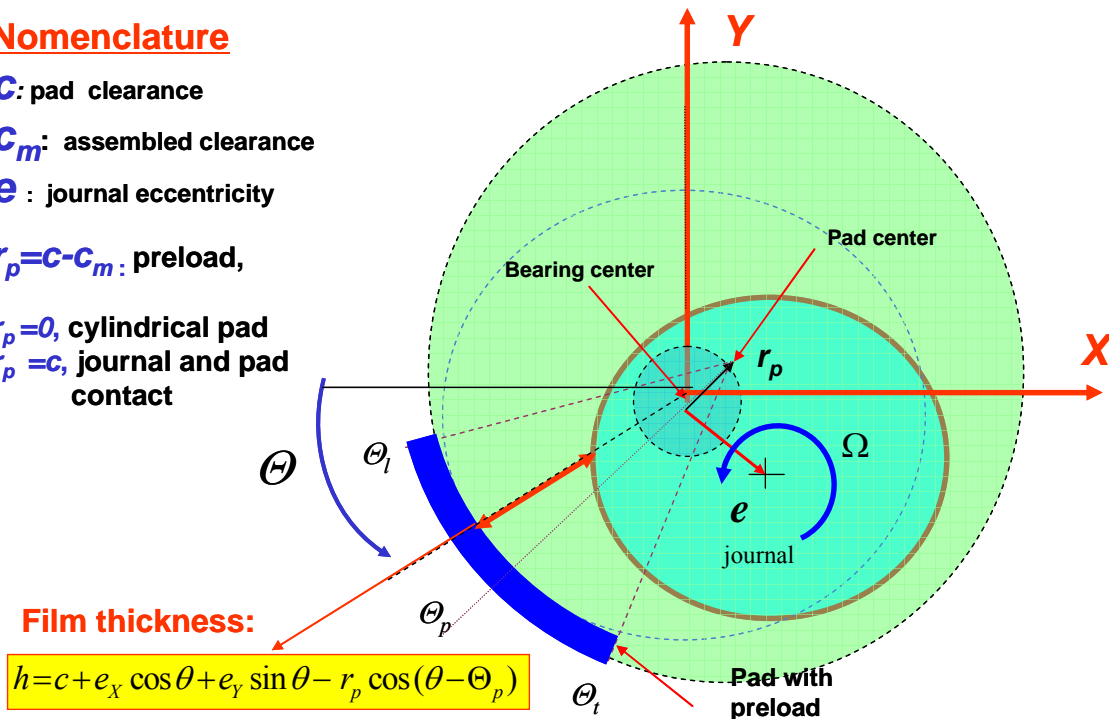

Figure 3. Geometry of a bearing pad with preload and description of film thickness (not to scale)

Governing equations for pressure generation and temperature transport

The modified [3,4,5] laminar flow Reynolds equation describing the generation of hydrodynamic pressure (P) in the thin film region $\{ \Theta_l \leq \Theta \leq \Theta_t, 0 < z < L \}$ of a bearing pad is

$$\frac{1}{R^2} \frac{\partial}{\partial \Theta} \left(\frac{h^3}{12 \mu_{(T)}} \frac{\partial P}{\partial \Theta} \right) + \frac{\partial}{\partial z} \left(\frac{h^3}{12 \mu_{(T)}} \frac{\partial P}{\partial z} \right) = \frac{\partial h}{\partial t} + \frac{\Omega}{2} \frac{\partial h}{\partial \Theta} + \left(\frac{\rho h^2}{12 \mu_{(T)}} \right) \frac{\partial^2 h}{\partial t^2} \quad (2)$$

where (ρ, μ) denote the lubricant density and viscosity, both temperature (T) dependent material properties. For example, $\mu = \mu_S e^{-\alpha_s(T-T_s)}$, with subindex S denoting supply conditions. The modified Reynolds equation includes temporal fluid inertia effects; hence, the flow model is strictly applicable to lubricant thin film flows induced by small amplitude journal motions about an equilibrium position.

For the laminar flow of an incompressible fluid and regarding the temperature as uniform along the axial direction, the energy transport equation under steady-state conditions is [6]

$$C_v \left[\frac{\partial}{R \partial \Theta} (\rho h U T) + \frac{\partial}{\partial z} (\rho h W T) \right] + Q_s = S = \frac{12 \mu}{h} \left(W^2 + \frac{\Omega^2 R^2}{12} + \left[U - \frac{\Omega R}{2} \right]^2 \right) \quad (3)$$

where T is the lubricant bulk-temperature¹ and $Q_s = \bar{h}_B (T - T_B) + \bar{h}_J (T - T_J)$ is the heat flow into the bearing and journal surfaces. Above, C_v is the lubricant specific heat, and (W, U) represent the axial and circumferential mean flow velocities given by

$$W = -\frac{h^2}{12 \mu} \frac{\partial P}{\partial z}; \quad U = -\frac{h^2}{12 \mu R} \frac{\partial P}{\partial \Theta} + \frac{\Omega R}{2} \quad (4)$$

Eq. (3) is representative of a bulk-flow model that balances the mechanical shear dissipation energy (S) to the thermal energy transport due to advection by the fluid flow and convection (Q_s) into the bearing surfaces. The heat convection coefficients (\bar{h}_B, \bar{h}_J) depend on the Prandtl number ($P_r = C_v \mu / \kappa$) and the flow condition defined by the local Reynolds number $\left(R_e = \frac{\rho U h}{\mu} \right)$ relative to the bearing and journal surfaces[7]. For laminar flow, $R_e \frac{c}{R} \leq 1$, Colburn's analogy renders the convection coefficients $\bar{h} = 3 P_r^{1/3} \frac{\kappa}{h}$. See Ref. [8] for details².

¹ The bulk temperature represents an average across the film thickness, i.e. $T = \frac{1}{h} \int_0^h T_{(\Theta, z, y)} dy$

² The THD model implements a number of heat transfer models, including those for fixed or developing wall temperatures and heat flows.

Boundary conditions for film pressure and temperature³

The pressure at a pad leading edge equals a supply condition, i.e.

$$0 \leq z \leq L : P(\Theta_l, z) = P_S \quad (5a)$$

The pressure is ambient at the bearing axial ends,

$$\Theta_l \leq \Theta \leq \Theta_r : P(\Theta, 0) = P_a ; P(\Theta, L) = P_a ; \quad (5b)$$

and also at the pad trailing edge,

$$0 \leq z \leq L : P(\Theta_r, z) = P_a \quad (5c)$$

Furthermore, within the whole flow domain, $P > P_{cav}$, i.e., the film pressure must be higher than the lubricant cavitation pressure. For a thorough discussion on lubricant cavitation and physical sound boundary conditions refer to **Notes 6** [9].

Lubricant is supplied into the bearing at a known supply temperature (T_S). The fluid temperature (T) gradually increases as it flows through the film thickness in a bearing pad since the lubricant removes shear induced mechanical energy. At the leading edge of a pad (Θ_l), there is mixing of the supplied cold lubricant flow rate (F_S) and a fraction of the hot lubricant flow (F_{up}) leaving the upstream with temperature T_{up} . The flow and thermal energy mixing conditions, as shown in schematic form in Figure 4, are specified as

$$\begin{aligned} F_{in} &= F_S + \lambda F_{up} \\ C_v (F_{in} T_{in} &= F_S T_S + \lambda F_{up} T_{up}) \end{aligned} \quad (6)$$

where $F_{in} = \int_0^L (\rho W h) \Big|_{\Theta_l} dz$ is the volumetric flow rate entering the pad at temperature T_{in} , and $F_{up} = \int_0^L (\rho W h) \Big|_{\Theta_r} dz$. The mixing parameter $\lambda (\in [0,1])$ is an empirical variable. Current or modern oil feed flow configurations incorporate direct impingement of the lubricant into a bearing pad, thus λ is low, to render cool lubricant temperature operation, i.e. $T_{in} \sim T_S$. In general, $\lambda \sim 0.6-0.9$ [10] for conventional feed arrangements with deep grooves and wide holes. In addition, note that the mixing thermal coefficient tends to increase ($\lambda \rightarrow 1$) with journal speed.

³ In a symmetric and aligned bearing, the pressure field is symmetric about the bearing mid axial plane. Thus, only the pressure field for one-half bearing length needs be calculated, say from $z = \frac{1}{2} L$ to $z=L$. In this case, $(\partial P / \partial z) = 0$ at $z = \frac{1}{2} L$.

That is, as the operating speed increases it becomes increasingly difficult to suminster fresh or cold lubricant into the fluid film bearing.

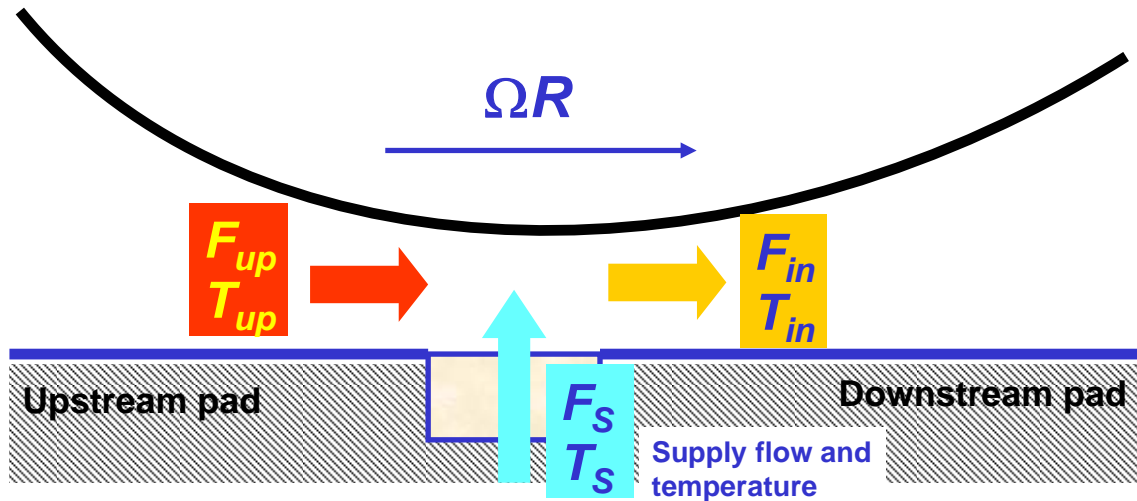

Figure 4. Schematic view of thermal mixing at the leading edge of a bearing pad (F : flow, T : temperature)

Since the thermal energy transport Eq. (3) is parabolic, there is no need to specify any other temperature along the other pad boundaries. Solution of Eq. (3) determines the lubricant temperature exiting a bearing pad through its axial sides ($z=0, L$) and at the pad trailing edge (Θ_t). Importantly enough, in the region where the lubricant cavitates ($P=P_{cav}$), the (current) analysis assumes there is no further generation of mechanical energy; and consequently, the fluid temperature in this region is constant. This is not an oversimplification, as verified by predictive analysis [11] and various published measurements, see [12,13].

Perturbation analysis⁴

Consider journal center motions of small amplitude ($\Delta X, \Delta Y \ll c$) about a static equilibrium position (e_{X_0}, e_{Y_0}) , as shown in Figure 5.

$$e_X = e_{X_0} + \Delta X_{(t)}, \quad e_Y = e_{Y_0} + \Delta Y_{(t)} \quad (7)$$

⁴ Follows the classical analysis of J.W. Lund in Refs. [14,15]

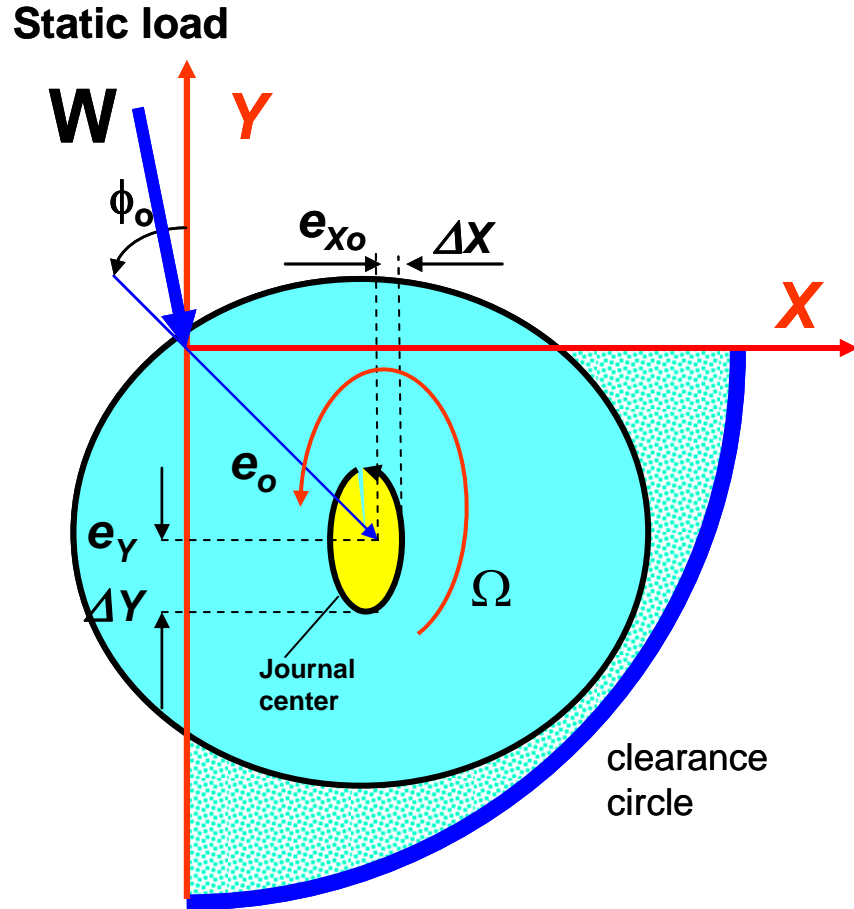

Figure 5. Depiction of small amplitude journal motions about an equilibrium position (Not to scale).

The film thickness is expressed as the superposition of an equilibrium (*zeroth-order*) thickness (h_0) and a *first-order* thickness (Δh_1), i.e.

$$\begin{aligned}
 h &= h_0 + \Delta h_{1(t)}, \\
 h_0 &= c - r_p \cos(\Theta - \Theta_p) + e_{x_0} \cos \Theta + e_{y_0} \sin \Theta, \\
 \Delta h_1 &= \Delta X_{(t)} \cos \Theta + \Delta Y_{(t)} \sin \Theta,
 \end{aligned} \tag{8}$$

with

$$\begin{aligned}
 \frac{\partial h_0}{\partial \Theta} &= +r_p \sin(\Theta - \Theta_p) - e_{x_0} \sin \Theta + e_{y_0} \cos \Theta; & \frac{\partial \Delta h_1}{\partial \Theta} &= -\Delta X_{(t)} \sin \Theta + \Delta Y_{(t)} \cos \Theta \\
 \frac{\partial h}{\partial t} &= \Delta \dot{X} \cos \Theta + \Delta \dot{Y} \sin \Theta, & \frac{\partial^2 h}{\partial t^2} &= \Delta \ddot{X} \cos \Theta + \Delta \ddot{Y} \sin \Theta
 \end{aligned} \tag{9}$$

The perturbation in film thickness leads naturally to a perturbation in film pressure, i.e.

$$P(\Theta, z, t) = P_0(\Theta, z) + \Delta P_1(\Theta, z, t), \quad (10)$$

$$\Delta P_1 = P_X \Delta X + P_Y \Delta Y + P_{\dot{X}} \Delta \dot{X} + P_{\dot{Y}} \Delta \dot{Y} + P_{\ddot{X}} \Delta \ddot{X} + P_{\ddot{Y}} \Delta \ddot{Y}$$

where P_0 is the *zeroth-order* or equilibrium pressure field defined by (e_{X_0}, e_{Y_0}) at steady operating conditions, and ΔP_1 is the perturbed dynamic pressure field⁵.

Define the linear operator

$$L[O] = \frac{1}{R} \frac{\partial}{\partial \Theta} \left(\frac{h_0^3}{12\mu} \frac{\partial [O]}{R \partial \Theta} \right) + \frac{\partial}{\partial z} \left(\frac{h_0^3}{12\mu} \frac{\partial [O]}{\partial z} \right) \quad (11)$$

Substitution of the pressure (P) and film thickness (h) into the modified Reynolds Eq. (2) gives the following equations for determination of the equilibrium and first order pressure fields

$$L(P_0) = \frac{1}{R^2} \frac{\partial}{\partial \Theta} \left(\frac{h_0^3}{12\mu} \frac{\partial P_0}{\partial \Theta} \right) + \frac{\partial}{\partial z} \left(\frac{h_0^3}{12\mu} \frac{\partial P_0}{\partial z} \right) = \frac{\Omega R}{2} \frac{\partial h_0}{R \partial \Theta} \quad (12a)$$

$$L(P_X) = \frac{\partial}{R \partial \Theta} \left\{ \cos \Theta \left[\frac{\Omega R}{2} - \frac{3h_0^2}{12\mu} \frac{\partial P_0}{R \partial \Theta} \right] \right\} - \frac{\partial}{\partial z} \left\{ \frac{3h_0^2}{12\mu} \cos \Theta \frac{\partial P_0}{\partial z} \right\} \quad (12b)$$

$$L(P_Y) = \frac{\partial}{R \partial \Theta} \left\{ \sin \Theta \left[\frac{\Omega R}{2} - \frac{3h_0^2}{12\mu} \frac{\partial P_0}{R \partial \Theta} \right] \right\} - \frac{\partial}{\partial z} \left\{ \frac{3h_0^2}{12\mu} \sin \Theta \frac{\partial P_0}{\partial z} \right\}$$

$$L(P_{\dot{X}}) = \cos \Theta; \quad L(P_{\dot{Y}}) = \sin \Theta \quad (12c)$$

$$L(P_{\ddot{X}}) = \left(\frac{\rho h_0^2}{12\mu} \right) \cos \Theta; \quad L(P_{\ddot{Y}}) = \left(\frac{\rho h_0^2}{12\mu} \right) \sin \Theta \quad (12d)$$

where $h_0 = c - r_p \cos(\Theta - \Theta_p) + e_{X_0} \cos \Theta + e_{Y_0} \sin \Theta$.

The **boundary conditions** for the solution of the zeroth- and first-order pressure fields follow. Note that in those boundaries where the pressure is fixed, say at ambient condition, the perturbed pressures must vanish, i.e. a homogeneous boundary condition. Hence,

$$P_0(\Theta_l, 0 < z < L) = P_S; \quad P_0(\Theta_t, 0 < z < L) = P_a$$

$$\Theta_l \leq \Theta \leq \Theta_t : P_0(\Theta, 0) = P_a; \quad P_0(\Theta, L) = P_a; \quad (13a)$$

$$\left[P_X = P_Y = P_{\dot{X}} = P_{\dot{Y}} = P_{\ddot{X}} = P_{\ddot{Y}} \right]_{(\Theta_l, z), (\Theta_t, z), (\Theta, 0), (\Theta, L)} = 0 \quad (13b)$$

⁵ The physical units of each perturbed pressure differ. For example,

$$(P_X, P_Y) \leftarrow \left[\frac{Pa}{m} \right], (P_{\dot{X}}, P_{\dot{Y}}) \leftarrow \left[\frac{Pa}{m/s} \right], (P_{\ddot{X}}, P_{\ddot{Y}}) \leftarrow \left[\frac{Pa}{m/s^2} \right]$$

At the inception of the film rupture or cavitation zone (Θ_c), $P_0=P_{cav}$, and $(\partial P_0/\partial \Theta)=0$. At this location, the first-order pressure fields also vanish, i.e. $P_X = P_Y = P_{\dot{X}} = P_{\dot{Y}} = P_{\ddot{X}} = P_{\ddot{Y}} = 0$. Other physical conditions may also apply⁶.

The current analysis does not consider a perturbation in the temperature field or the lubricant material properties (density and viscosity). Recall the journal motions are small in amplitude affecting little the steady-state temperature field. However, in bearings and seals operating in the turbulent flow regime, the journal motion does affect the flow condition and hence, there is the need to account for temporal variations in the fluid material viscosity and density, see **Notes 10** [6]

Bearing reaction forces and force coefficients

The hydrodynamic pressure field generated in each pad acts on the journal to generate a fluid film reaction force with components (F_X, F_Y) . Integration of the pressure fields gives

$$\begin{bmatrix} F_X \\ F_Y \end{bmatrix} = \sum_{k=1}^{N_{pads}} \begin{bmatrix} F_{X_k} \\ F_{Y_k} \end{bmatrix} = \sum_{k=1}^{N_{pad}} \left\{ \int_0^L \int_{\Theta_i}^{\Theta_f} P_{(\Theta,z,t)_k} \begin{bmatrix} \cos \Theta \\ \sin \Theta \end{bmatrix}_k R d\Theta_k dz \right\} \quad (14)$$

Substitution of Eq. (10) gives for the k_{th} pad

$$\begin{bmatrix} F_X \\ F_Y \end{bmatrix}_k = \int_0^L \int_{\Theta_i}^{\Theta_f} \left\{ P_0 + P_X \Delta X + P_Y \Delta Y + P_{\dot{X}} \Delta \dot{X} + P_{\dot{Y}} \Delta \dot{Y} + P_{\ddot{X}} \Delta \ddot{X} + P_{\ddot{Y}} \Delta \ddot{Y} \right\}_k \begin{bmatrix} \cos \Theta \\ \sin \Theta \end{bmatrix}_k R d\Theta dz \quad (15)$$

The components of a pad reaction force are expressed in terms of stiffness, damping and inertia force coefficients $(K, C, M)_{\alpha\beta=X,Y}$

$$\begin{bmatrix} F_{X(t)} \\ F_{Y(t)} \end{bmatrix}_k = \begin{bmatrix} F_{X_0} \\ F_{Y_0} \end{bmatrix}_k - \begin{bmatrix} K_{XX} & K_{XY} \\ K_{YX} & K_{YY} \end{bmatrix}_k \begin{bmatrix} \Delta X \\ \Delta Y \end{bmatrix} - \begin{bmatrix} C_{XX} & C_{XY} \\ C_{YX} & C_{YY} \end{bmatrix}_k \begin{bmatrix} \Delta \dot{X} \\ \Delta \dot{Y} \end{bmatrix} - \begin{bmatrix} M_{XX} & M_{XY} \\ M_{YX} & M_{YY} \end{bmatrix}_k \begin{bmatrix} \Delta \ddot{X} \\ \Delta \ddot{Y} \end{bmatrix} \quad (16)$$

The bearing pad force coefficients follow from

⁶ See for example, Zhang, Y., 1990, "Starting Pressure Boundary Conditions for Perturbed Reynolds Equation," *ASME Journal of Lubrication Technology*, Vol. 112, pp. 551-556.

$$\begin{aligned}
\begin{bmatrix} K_{XX} & K_{XY} \\ K_{YX} & K_{YY} \end{bmatrix}_k &= - \int_0^L \int_{\Theta_1}^{\Theta_2} \begin{bmatrix} \cos \Theta \\ \sin \Theta \end{bmatrix} [P_X \quad P_Y]_k R d\Theta dz; \\
\begin{bmatrix} C_{XX} & C_{XY} \\ C_{YX} & C_{YY} \end{bmatrix}_k &= - \int_0^L \int_{\Theta_1}^{\Theta_2} \begin{bmatrix} \cos \Theta \\ \sin \Theta \end{bmatrix} [P_{\dot{X}} \quad P_{\dot{Y}}]_k R d\Theta dz; \\
\begin{bmatrix} M_{XX} & M_{XY} \\ M_{YX} & M_{YY} \end{bmatrix}_k &= - \int_0^L \int_{\Theta_1}^{\Theta_2} \begin{bmatrix} \cos \Theta \\ \sin \Theta \end{bmatrix} [P_{\ddot{X}} \quad P_{\ddot{Y}}]_k R d\Theta dz;
\end{aligned} \tag{17}$$

The individual pad forces and force coefficients add to render the components of reaction force and the force coefficients for the whole bearing, i.e.,

$$F_\alpha = \sum_{k=1}^{N_{pads}} (F_\alpha)_k; \quad K_{\alpha\beta} = \sum_{k=1}^{N_{pads}} (K_{\alpha\beta})_k; \quad C_{\alpha\beta} = \sum_{k=1}^{N_{pads}} (C_{\alpha\beta})_k; \quad M_{\alpha\beta} = \sum_{k=1}^{N_{pads}} (M_{\alpha\beta})_k \quad \alpha, \beta = X, Y \tag{18}$$

Calculation of the bearing static equilibrium position

A fluid film bearing supports an applied load \mathbf{W} . This load has components (W_X, W_Y) along the (X, Y) fixed axes. At the rated operating condition \mathbf{W} produces a static displacement of the journal center, better known as the equilibrium journal eccentricity \mathbf{e} , with components (e_{X_0}, e_{Y_0}) .

The static balance of forces is

$$W_X + F_X = 0, \quad W_Y + F_Y = 0 \tag{19}$$

Most fluid film bearing analyses predict the bearing reaction forces due to specified journal center static displacements. Thus, in practice, an iterative procedure is implemented to predict the journal equilibrium position given the applied load.

Let the journal operate with eccentricity $(e_X, e_Y)_j$ at the j^{th} iteration and giving the bearing reaction force components $(F_X, F_Y)_j$. Then, corrections $(\delta e_X, \delta e_Y)_j$ to the journal eccentricity that will render reaction forces converging towards the applied external load are given by the Newton-Raphson procedure

$$\begin{bmatrix} \delta e_{X_j} \\ \delta e_{Y_j} \end{bmatrix} = \begin{bmatrix} K_{XX} & K_{XY} \\ K_{YX} & K_{YY} \end{bmatrix}_j^{-1} \begin{bmatrix} W_X + F_{X_j} \\ W_Y + F_{Y_j} \end{bmatrix} \quad (20a)$$

and

$$\begin{bmatrix} e_{X_{j+1}} \\ e_{Y_{j+1}} \end{bmatrix} = \begin{bmatrix} e_{X_j} \\ e_{Y_j} \end{bmatrix} + \begin{bmatrix} \delta e_{X_j} \\ \delta e_{Y_j} \end{bmatrix} \quad (20b)$$

Above, the bearing *pseudo or temporal stiffness* coefficients ($K_{\alpha\beta=X,Y}$) are evaluated at $(e_X, e_Y)_j$.

Upon convergence, the differences in forces in Eq. (19) become negligible, i.e. $(W+F)_{X,Y} \rightarrow 0$; and the stiffness coefficients are those of the bearing at its equilibrium position.

Note that the bearing reaction forces are highly nonlinear functions of the journal position or eccentricity function; thus, convergence of the Newton-Raphson algorithm relies heavily on the closeness of the initial journal eccentricity components to the actual equilibrium eccentricity. Of course, the fact noted is common in the solution of any nonlinear system of equations.

Generalization of the perturbation method

Consider small amplitude harmonic journal motions $(\Delta e_X, \Delta e_Y)$ with whirl frequency ω about the equilibrium position (e_{X_0}, e_{Y_0}) . The film thickness (h) is the real part of the following expression

$$h = h_0 + [\Delta e_X \cos \Theta + \Delta e_Y \sin \Theta] e^{i\omega t} = h_0 + \Delta e_\sigma h_\sigma e^{i\omega t} ; \sigma=X,Y ; i = \sqrt{-1} \quad (21)$$

with h_0 as the equilibrium film thickness at (e_{X_0}, e_{Y_0}) , and $h_X = \cos \Theta$, $h_Y = \sin \Theta$. Note that,

$$\frac{\partial h}{\partial t} = \frac{\partial (h_0 + \Delta e_\sigma h_\sigma e^{i\omega t})}{\partial t} = i\omega \Delta e_\sigma h_\sigma e^{i\omega t}, \quad \frac{\partial^2 h}{\partial t^2} = -\omega^2 \Delta e_\sigma h_\sigma e^{i\omega t} \quad (22)$$

The pressure field is written as the superposition of zeroth and first order fields,

$$P = P_0 + \Delta e_\sigma P_\sigma e^{i\omega t} ; \sigma=X,Y. \quad (23)$$

The zeroth-order (P_0) is the equilibrium pressure field satisfying

$$L(P_0) = \frac{1}{R^2} \frac{\partial}{\partial \Theta} \left(\frac{h_0^3}{12\mu} \frac{\partial P_0}{\partial \Theta} \right) + \frac{\partial}{\partial z} \left(\frac{h_0^3}{12\mu} \frac{\partial P_0}{\partial z} \right) = \frac{\Omega R}{2} \frac{\partial h_0}{R \partial \Theta} \quad (24=12a)$$

and the first-order complex pressure fields $P_{\sigma=X,Y}$ due to the journal center motions satisfy

$$L(P_\sigma) = \frac{\Omega}{2} \frac{\partial h_\sigma}{\partial \Theta} + \left\{ i - \left(\frac{\rho h_0^2 \omega}{12 \mu} \right) \right\} \omega h_\sigma - \frac{\partial}{R \partial \Theta} \left(\frac{3 h_0^2 h_\sigma}{12 \mu} \frac{\partial P_0}{R \partial \Theta} \right) - \frac{\partial}{\partial z} \left(\frac{3 h_0^2 h_\sigma}{12 \mu} \frac{\partial P_0}{\partial z} \right); \quad \sigma=X,Y$$

or (25)

$$L(P_\sigma) = \left\{ i - \left(\frac{\rho h_0^2 \omega}{12 \mu_{(T)}} \right) \right\} \omega h_\sigma + \frac{\partial}{R \partial \Theta} \left(\frac{\Omega R}{2} h_\sigma - \frac{3 h_0^2}{12 \mu_{(T)}} h_\sigma \frac{\partial P_0}{R \partial \Theta} \right) - \frac{\partial}{\partial z} \left(\frac{3 h_0^2 h_\sigma}{12 \mu_{(T)}} \frac{\partial P_0}{\partial z} \right)$$

Above $\left(\frac{\rho h_0^2 \omega}{12 \mu} \right) = \text{Re}_s$ represents a **local squeeze film Reynolds number**.

The F_X and F_Y components of the fluid film bearing reaction force are

$$F_\sigma = \int_0^L \int_0^\Theta P h_\sigma R d\Theta dz = \int_0^L \int_0^\Theta \left\{ P_0 + \Delta e_\sigma P_\sigma e^{i\omega t} \right\} h_\sigma R d\Theta dz = F_{\sigma_0} - Z_{\sigma\beta} \Delta e_\sigma e^{i\omega t}; \quad \sigma, \beta=X,Y \quad (26)$$

where the components of the static (equilibrium) bearing reaction force at journal position (e_{X_0}, e_{Y_0}) are

$$F_{\sigma_0} = \int_0^L \int_0^\Theta P_0 h_\sigma R d\Theta dz = -W_\sigma; \quad \sigma=X,Y \quad (27)$$

and the bearing impedances ($Z_{\beta\sigma}$) rendering the stiffness, damping and inertia force coefficients, $(K, C, M)_{\alpha\beta=X,Y}$, are evaluated from the real and imaginary parts of

$$Z_{\beta\sigma} = \left(K_{\beta\sigma} - \omega^2 M_{\beta\sigma} \right) + i \omega C_{\beta\sigma} = - \int_0^L \int_0^\Theta P_\sigma h_\beta R d\Theta dz; \quad \beta, \sigma=X,Y \quad (28)$$

Numerical solution of film pressure equations: equilibrium and first-order

The finite element method (FEM) is well suited for the numerical solution of elliptic type differential equations such as Reynolds Equation. Complicated geometrical domains are well represented by finite elements, hence its major advantage over other methods such as finite differences. Another advantage becomes apparent later as the systems of equations for solution of the zeroth and first order pressure fields have the same (global) fluidity matrix. This feature allows the most rapid evaluation of the bearing dynamic force coefficients.

Figure 6 depicts a flow region divided into a collection of N_{em} four-noded isoparametric finite elements. The pressure over an element (Ω^e) is given by a linear combination of nodal values

$\{\bar{P}_i\}_{i=1}^{n_{pe}}$ and bilinear shape functions $\{\Psi_i^e\}_{i=1}^{n_{pe}}$, i.e.

$$P_0^e = \sum_{i=1}^{n_{pe}} \Psi_i^e \bar{P}_{0_i}^e, \quad P_\sigma^e = \sum_{i=1}^{n_{pe}} \Psi_i^e \bar{P}_{\sigma_i}^e; \quad \sigma=X,Y \quad (29)$$

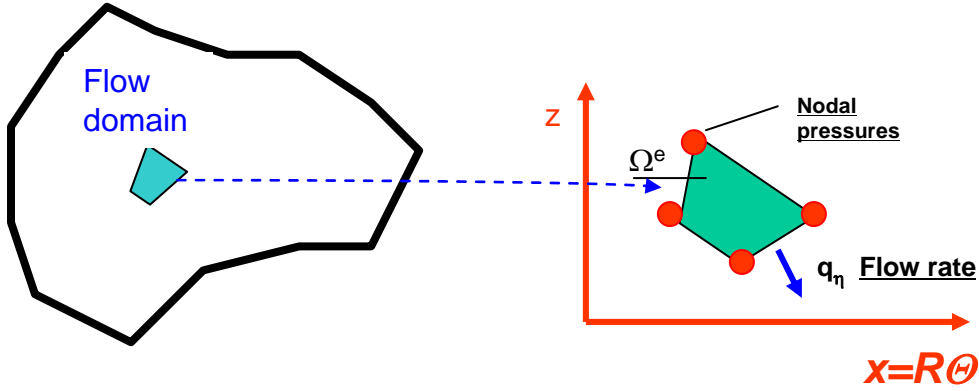

Figure 6. Depiction of general domain of flow field and finite element representation

The Galerkin formulation [15] reduces the PDE (12a) for the equilibrium pressure field P_0 within a finite element (Ω^e) into the algebraic system of linear equations

$$[\mathbf{k}]^e \{\bar{\mathbf{P}}_0\}_G = -\{\mathbf{q}_0\}^e + \{\mathbf{f}_0\}^e; \quad \sum_{j=1}^{n_{pe}} k_{ij}^e \bar{P}_{0_j}^e = -(q_0)_i^e + (f_0)_i^e; \quad i,j=1, N_{pe} \quad (30)$$

where the coefficients of the element fluidity matrix $[\mathbf{k}]^e$ are

$$k_{ij}^e = k_{ji}^e = \iint_{\Omega^e} \left[\left(\frac{h_0^3}{12\mu(T)} \right)^e \left\{ \frac{\partial \Psi_i}{\partial x} \frac{\partial \Psi_j}{\partial x} + \frac{\partial \Psi_i}{\partial z} \frac{\partial \Psi_j}{\partial z} \right\}^e \right] dx dz \quad i,j=1, \dots, N_{pe} \quad (31)$$

and the right hand side vectors denote the shear flow effect and nodal flow rates,

$$f_{0_i}^e = \frac{\Omega R}{2} \iint_{\Omega^e} \left(h_0 \frac{\partial \Psi_i}{\partial x} \right)^e dx dz; \quad q_{0_i}^e = \oint_{\Gamma^e} \Psi_i^e q_{\eta_0} d\Gamma^e \quad i=1, \dots, N_{pe} \quad (32)$$

with

$$q_{\eta_0} = -\frac{h_0^3}{12\mu(T)} \frac{\partial P_0}{\partial \eta} + \frac{h_0 \Omega R}{2} \eta_x \quad (33)$$

as the flow through the element boundary (Γ^e). Note above that the fluid viscosity is a function of the temperature, $\mu = \mu_S e^{-\alpha_v(T-T_s)}$; thys, varying over the flow domain.

The integrals in Eqns. (31, 32) are evaluated numerically over a master isoparametric element ($\hat{\Omega}$) with normalized coordinates. Reddy and Gartling [16] explain the coordinate transformation and numerical integration procedure using Gauss-Legendre quadrature formulas.

Eqns. (30) are assembled over the whole flow domain and then condensed by enforcing the corresponding boundary conditions. The resultant global set of equations is

$$[\mathbf{k}]_G \{\bar{\mathbf{P}}_0\}_G = -\{\mathbf{Q}\}_G + \{\mathbf{F}\}_G \quad (34)$$

where $[\mathbf{k}]_G = \bigcup_{e=1}^{Nem} [\mathbf{k}]^e$, $\{\mathbf{Q}\}_G = \bigcup_{e=1}^{Nem} \{\mathbf{q}\}^e$, $\{\mathbf{F}\}_G = \bigcup_{e=1}^{Nem} \{\mathbf{f}\}^e$. The global fluidity matrix $[\mathbf{k}]_G$ is symmetric, easily decomposed into its upper and lower triangular form (Cholesky algorithm), i.e.

$$[\mathbf{k}]_G = [\mathbf{L}]_G [\mathbf{U}]_G = [\mathbf{L}]_G [\mathbf{L}]_G^T \quad (35)$$

A process of back- and forward-substitutions then renders the discrete zeroth order pressure field $\{\bar{\mathbf{P}}_0\}_G$:

$$[\mathbf{L}]_G \left([\mathbf{L}]_G^T \{\bar{\mathbf{P}}_0\}_G \right) = -\{\mathbf{Q}\}_G + \{\mathbf{F}\}_G \quad (36)$$

Note that $\{\mathbf{Q}\}_G = \mathbf{0}$ denotes the addition of flow rates at a node. Hence the components of this vector are nil at each internal node of the finite element domain.

A similar procedure follows for solution of the perturbed (dynamic) pressure fields, P_X and P_Y , due to journal harmonic displacements ($\Delta e_X, \Delta e_Y$) with whirl frequency ω . PDEs (25)

become

$$\sum_{j=1}^{n_{pe}} k_{ij}^e \bar{P}_{\sigma_j}^e = (f_{\sigma})_i^e - \sum_{j=1}^{n_{pe}} (S_{\sigma})_{ij}^e \bar{P}_{0_j}^e - (q_{\sigma})_i^e \quad ; \quad \sigma = X, Y \quad i, j = 1, \dots, N_{pe} \quad (37)$$

with $h_X = \cos \Theta$, $h_Y = \sin \Theta$, $\mathbf{i} = \sqrt{-1}$. Defining $\Psi_{i,x} = \frac{\partial \Psi_i}{\partial x}$ and $\Psi_{i,z} = \frac{\partial \Psi_i}{\partial z}$. Above, for perturbations along the X -direction,

$$[\mathbf{k}]^e \{\bar{\mathbf{P}}_X\}_G = \{\mathbf{f}_X\}^e - [\mathbf{S}_X]^e \{\bar{\mathbf{P}}_0\}_G - \{\mathbf{q}_X\}^e \quad (37a)$$

for example.

In Equations (37)

$$\begin{aligned}
 (f_\sigma)_i^e &= \frac{\Omega R}{2} \iint_{\Omega^e} (h_\sigma \Psi_{i,x}^e) dx dz + \iint_{\Omega^e} h_\sigma \left[\frac{\rho \omega^2 h_0^2}{12 \mu_{(T)}} \right] \Psi_i^e dx dz - \mathbf{i} \omega \iint_{\Omega^e} h_\sigma [\Psi_i^e] dx dz \\
 (S_\sigma)_{ij}^e &= \iint_{\Omega^e} \left(\frac{3 h_0^2 h_\sigma}{12 \mu_{(T)}} \right)^e \{ \Psi_{i,x} \Psi_{j,x} + \Psi_{i,z} \Psi_{j,z} \}^e dx dz, \quad i,j=1,\dots,N_{pe} \\
 (q_\sigma)_i^e &= \oint_{\Gamma^e} \Psi_i^e (q_\sigma)_\eta d\Gamma^e; \quad (q_\sigma)_\eta = -\frac{h_0^3}{12 \mu_{(T)}} \frac{\partial P_\sigma}{\partial \eta} - \frac{3 h_0^2 h_\sigma}{12 \mu_{(T)}} \frac{\partial P_0}{\partial \eta} + \frac{\Omega R}{2} h_\sigma \eta_x
 \end{aligned} \tag{38}$$

The assembly process of the first order *FE* equations renders a fluidity matrix identical to that for the equilibrium pressure field. Thus, the perturbed pressure fields can be calculated rapidly since the global fluidity matrix $[\mathbf{k}]_G$ is originally obtained and decomposed in the procedure to find the equilibrium pressure field $\{\bar{\mathbf{P}}_0\}_G$, see Eq. (36).

In practice, the process does not require specification of a whirl frequency (ω) nor conducting several calculations to discern the stiffnesses from the mass coefficients.

For (P_X, P_Y) from Eqs. (12b):

$$\sum_{j=1}^{n_{pe}} k_{ij}^e \bar{P}_{\sigma_j}^e = (f_\sigma)_i^e - \sum_{j=1}^{n_{pe}} (S_\sigma)_{ij}^e \bar{P}_{0_j}^e - (q_\sigma)_i^e; \quad \sigma=X, Y \quad i=1,\dots,N_{pe} \tag{39a}$$

$$(f_\sigma)_i^e = \frac{\Omega R}{2} \iint_{\Omega^e} (h_\sigma \Psi_{i,x}^e) dx dz; \quad (S_\sigma)_{ij}^e = \iint_{\Omega^e} \left(\frac{3 h_0^2 h_\sigma}{12 \mu_{(T)}} \right)^e \{ \Psi_{i,x} \Psi_{j,x} + \Psi_{i,z} \Psi_{j,z} \}^e dx dz \tag{39b}$$

To make the global system of equations

$$[\mathbf{L}]_G \left([\mathbf{L}]_G^T \{ \bar{\mathbf{P}}_\sigma \}_G \right) = -\{ \mathbf{Q} \}_G + \{ \mathbf{F}_\sigma \}_G - [\mathbf{S}_\sigma]_G \{ \mathbf{P}_0 \}_G \tag{39c}$$

For $(P_{\dot{X}}, P_{\dot{Y}})$ from Eqs. (12c):

$$\sum_{j=1}^{n_{pe}} k_{ij}^e \bar{P}_{\dot{\sigma}_j}^e = (f_{\dot{\sigma}})_i^e - (q_{\dot{\sigma}})_i^e; \quad \dot{\sigma}=\dot{X}, \dot{Y} \quad i=1,\dots,N_{pe} \tag{40a}$$

$$(f_{\dot{\sigma}})_i^e = - \iint_{\Omega^e} h_\sigma [\Psi_i^e] dx dz \quad i=1,\dots,N_{pe} \tag{40b}$$

Giving the global system of equations

$$[\mathbf{L}]_{\mathbf{G}} \left([\mathbf{L}]_{\mathbf{G}}^{\mathbf{T}} \{ \bar{\mathbf{P}}_{\ddot{\sigma}} \}_{\mathbf{G}} \right) = - \{ \mathbf{Q} \}_{\mathbf{G}} + \{ \mathbf{F}_{\ddot{\sigma}} \}_{\mathbf{G}} \quad (40c)$$

For $(P_{\ddot{X}}, P_{\ddot{Y}})$ from Eqs. (12c):

$$\sum_{j=1}^{n_{pe}} k_{ij}^e \bar{P}_{\ddot{\sigma}_j}^e = (f_{\ddot{\sigma}})_i^e - (q_{\ddot{\sigma}})_i^e \quad ; \quad \ddot{\sigma} = \ddot{X}, \ddot{Y} \quad i=1, \dots, N_{pe} \quad (41a)$$

$$(f_{\ddot{\sigma}})_i^e = - \iint_{\Omega^e} h_{\sigma} \left[\frac{\rho h_0^2}{12 \mu_{(T)}} \right]^e \Psi_i^e dx dz \quad i=1, \dots, N_{pe} \quad (41b)$$

Giving the system of equations

$$[\mathbf{L}]_{\mathbf{G}} \left([\mathbf{L}]_{\mathbf{G}}^{\mathbf{T}} \{ \bar{\mathbf{P}}_{\ddot{\sigma}} \}_{\mathbf{G}} \right) = - \{ \mathbf{Q} \}_{\mathbf{G}} + \{ \mathbf{F}_{\ddot{\sigma}} \}_{\mathbf{G}} \quad (41c)$$

Solution of the system of equations for the first order fields is performed quickly with the procedure

$$\begin{aligned} [\mathbf{L}]_{\mathbf{G}} \left([\mathbf{L}]_{\mathbf{G}}^{\mathbf{T}} \{ \mathbf{X} \}_{\mathbf{G}} \right) &= \{ \mathbf{Y} \}_{\mathbf{G}} \\ [\mathbf{L}]_{\mathbf{G}} \{ \mathbf{Z} \}_{\mathbf{G}} &= \{ \mathbf{Y} \}_{\mathbf{G}} \rightarrow \text{find } \{ \mathbf{Z} \}_{\mathbf{G}} \\ [\mathbf{L}]_{\mathbf{G}}^{\mathbf{T}} \{ \mathbf{X} \}_{\mathbf{G}} &= \{ \mathbf{Z} \}_{\mathbf{G}} \rightarrow \text{find } \{ \mathbf{X} \}_{\mathbf{G}} \end{aligned} \quad (42)$$

which does not require inversion of matrices but only 2- N forward and backward substitutions.

Numerical solution of the transport equation for fluid film mean temperature

The transport of energy equation (3) is of parabolic type. Hence, a control volume method with upwinding [17] is chosen to solve for the temperature field. Figure 7 depicts the control volume for integration of the thermal energy transport Eq. (3). Note that, in accordance with practice and measurements, the fluid bulk-temperature (T) does not vary along the bearing axial length. In the figure, $\{T^e, T^w \text{ and } T^n\}$ are temperatures at the east, west and north faces of the P -control volume; while $\{T_E, T_W, T_P\}$ are nodal temperatures at the center of the control-volumes.

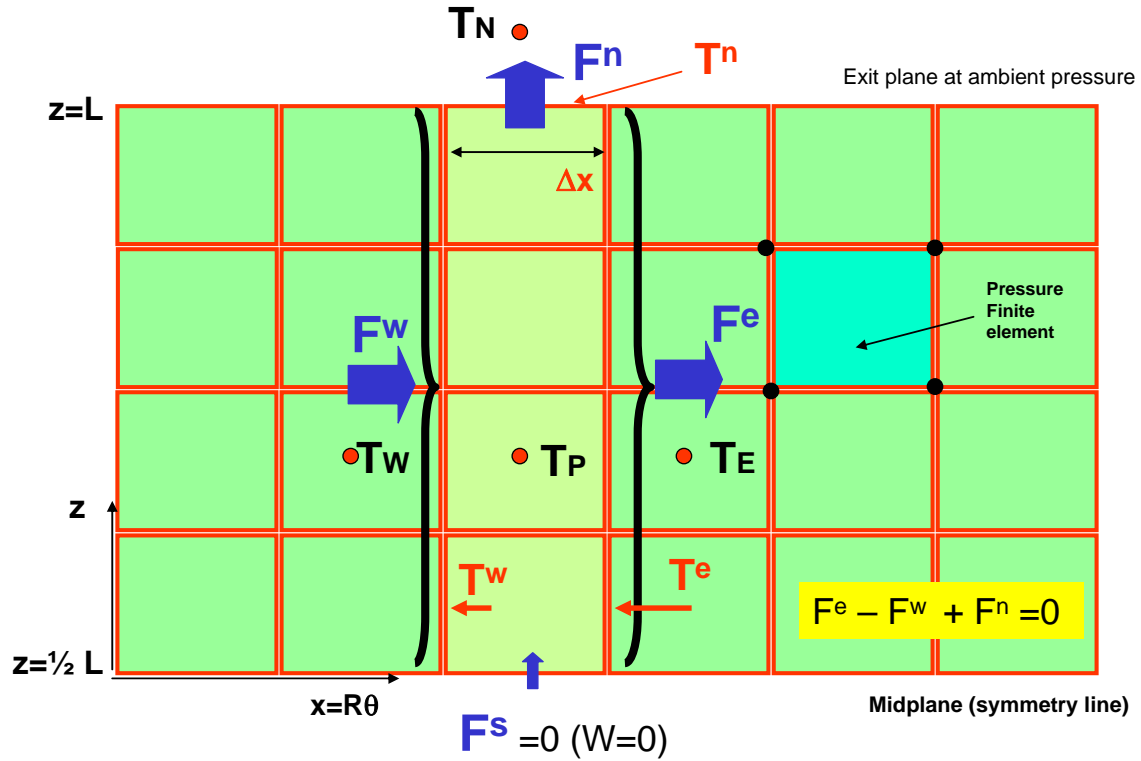

Figure 7. Control volumes for integration of energy transport equation (F : flow, T : temperature)

Integration of the energy transport Eq. (3) over $1/2$ axial length of the bearing (T -control volume) leads to:

$$C_v \left[\int_{L/2}^L (\rho h U T)_w^e dz + \int_w^e (\rho h W T)_{z=L/2}^L dx \right] = \int_{L/2}^L (S - Q_s) dz dx \quad (43)$$

with the source (energy dissipation) term $S = \frac{12 \mu_{(T)}}{h} \left(W^2 + \frac{\Omega^2 R^2}{12} + \left[U - \frac{\Omega R}{2} \right]^2 \right)$ (44)

and heat flow into the bearing and journal surfaces $Q_s = \bar{h}_B (T - T_B) + \bar{h}_J (T - T_J)$ (45)

Since the film temperature is regarded as constant along the axial direction, Eq. (43) reduces to

$$C_v \left[T^e \int_{L/2}^L (\rho h U)^e dz - T^w \int_{L/2}^L (\rho h U)^w dx + T^n \int_w^e (\rho h W)_{z=L} dx \right] = \int_{L/2}^L (S - Q_s) dz dx \quad (46)$$

Recall that the axial flow velocity is null⁷ at the midplane of a bearing pad, i.e., $W=0$ at $z=0$.

Define mass flow rates (F) through the control volume faces as

$$\begin{aligned} F^e &= \int_{L/2}^L (\rho h U)^e dz \approx \sum_J^{N_{e_z}} (\rho h U)_J^e \Delta z, \\ F^w &= \int_{L/2}^L (\rho h U)^w dz \approx \sum_J^{N_{e_z}} (\rho h U)_J^w \Delta z, \\ F^n &= \int_w^e (\rho h W)_{z=L/2} dx; \quad F^s = \int_w^e (\rho h W)_{z=0} dx = 0 \end{aligned} \quad (47)$$

where N_{e_z} is the number of P -finite elements along the axial direction. The source term from shear drag power is

$$S^P = \int_{L/2}^L S dz dx \approx \sum_J^{N_{e_z}} \left(\frac{12 \mu_{(T)}}{h} \left(W^2 + \frac{\Omega^2 R^2}{12} + \left[U - \frac{\Omega R}{2} \right]^2 \right) \right)_J^P \Delta z \Delta x, \quad (48a)$$

From mass flow continuity $[F^e - F^w + F^n - 0] = 0$. Assume for simplicity that the bearing (T_B) and journal (T_J) temperatures are constant along the axial direction. An identical statement is made for the heat convection coefficients (\bar{h}_B, \bar{h}_J) . Then,

$$Q^P = \int_{L/2}^L Q_s dz dx \approx T_p (\bar{h}_B + \bar{h}_J) \frac{L}{2} \Delta x - (\bar{h}_B T_B + \bar{h}_J T_J) \frac{L}{2} \Delta x \quad (48b)$$

With the definitions above, the discretized algebraic form of the energy transport equation is:

$$C_v [F^e T^e - F^w T^w + F^n T^n] = S^P - Q^P \quad (49)$$

Implementation of the **upwind scheme** [17] for the thermal flux transport terms gives:

$$\begin{aligned} F^e T^e &= \llbracket F^e, 0 \rrbracket T_p - \llbracket -F^e, 0 \rrbracket T_E \\ F^w T^w &= \llbracket F^w, 0 \rrbracket T_w - \llbracket -F^w, 0 \rrbracket T_p \\ F^n T^n &= \llbracket F^n, 0 \rrbracket T_p - \llbracket -F_n, 0 \rrbracket T_N \end{aligned} \quad (50)$$

with $\llbracket a, 0 \rrbracket = \frac{1}{2} [a + |a|]$; $\llbracket -a, 0 \rrbracket = \frac{1}{2} [-a + |a|]$; $\llbracket a, 0 \rrbracket - \llbracket -a, 0 \rrbracket = a$;

⁷ This is because the pressure field is symmetric along the axial direction. That is, the peak pressure occurs at the axial mid-plane of the bearing

where T_N is a fluid sump temperature (outside) of the bearing discharge plane⁸.

Substitution of Eq. (50) into Eq. (49) renders the control-volume integral form of the energy transport equation

$$a_p T_P = a_w T_W + a_e T_E + a_n T_N + S^P + Q_{JB}^P \quad (51)$$

where

$$a_e = C_v \llbracket -F^e, 0 \rrbracket; \quad a_w = C_v \llbracket F^w, 0 \rrbracket; \quad a_n = C_v \llbracket -F^n, 0 \rrbracket \quad (52a)$$

$$a_p = a_e + a_w + a_n + (\bar{h}_B + \bar{h}_J) \frac{L}{2} \Delta x \quad (52c)$$

$$Q_{JB}^P = (\bar{h}_B T_B + \bar{h}_J T_J) \frac{L}{2} \Delta x \quad (52c)$$

The system of equations (51) is easily solved with a simple recursive algorithm. If the lubricant flow is from left to right (w to e), then $F^w > 0; F^e > 0 \rightarrow a_e = 0$; and the energy transport equation reduces to

$$a_p T_P = a_w T_W + a_n T_N + S^P + Q_{JB}^P \quad (53)$$

If lubricant flows outward at the exit plane $z = \frac{1}{2} L$, $F^n > 0 \rightarrow a_n = 0$, and the energy transport equation further reduces to

$$a_p T_P = a_w T_W + S^P + Q_{JB}^P \quad (54)$$

where $a_p = a_w + (\bar{h}_B + \bar{h}_J) \frac{L}{2} \Delta x$. This last equation, revealing the parabolic nature of the thermal energy transport, shows the film temperature increases due to shear power dissipation effects. Note that $Q_{JB}^P = 0$ for adiabatic boundaries, i.e. $(\bar{h}_B = \bar{h}_J = 0)$, i.e. no heat flow into or from the bearing and journal.

The algebraic equations for solutions of the pressure and temperature fields are programmed in FORTRAN with a Graphical User Interface in MS Excel® for input of bearing data and operating conditions and output of predictions that include the bearing torque and flow rate, static journal eccentricity, dynamic force coefficients, and the pressure and temperature fields. For completeness in the description, Figure 8 depicts the relationship between a finite element for evaluation of the film pressure and the control-volume for temperature.

⁸ $F^n < 0$ means that flow is entering (instead of leaving) the bearing at the exit plane $z = \frac{1}{2} L$. This condition is not unusual in the zone of lubricant cavitation. However, in practice the value of sump temperature is not well known a-priori.

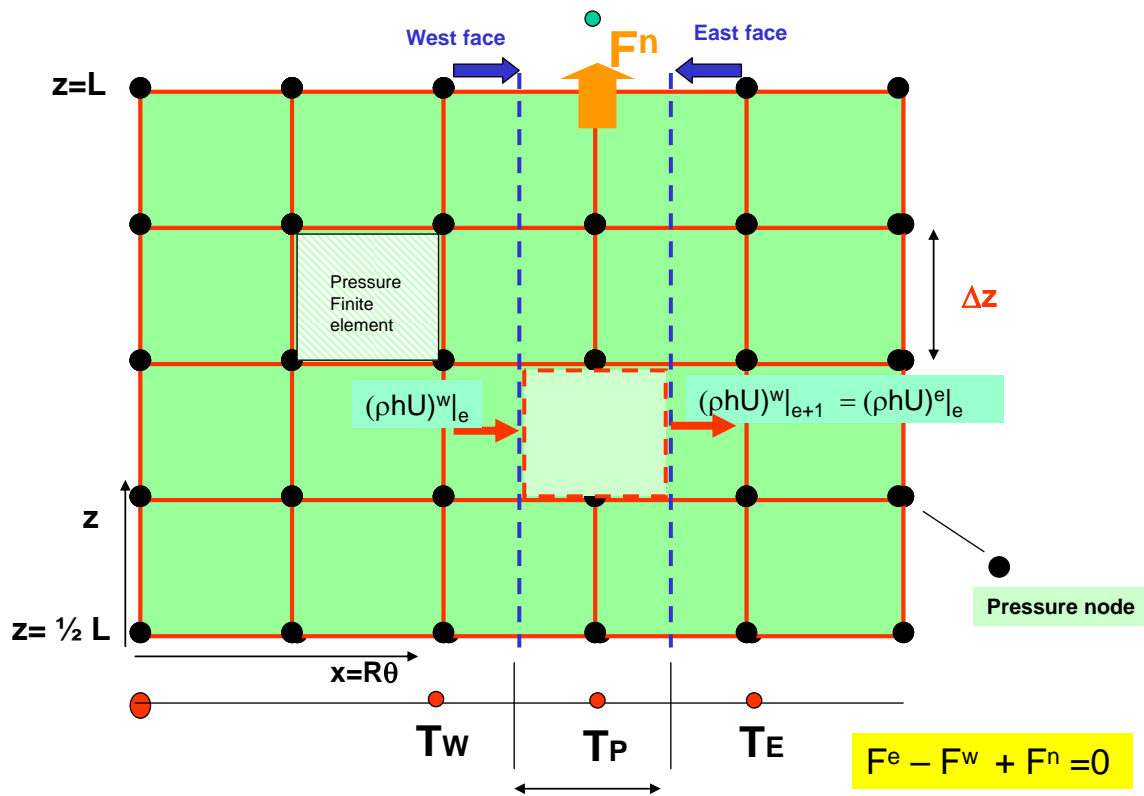

Figure 8. Flow fluxes through faces of temperature-CV and relation to pressure finite elements

Examples

Model predictions for test bearings reported in the literature were obtained. The benchmark cases included one and two grooved journal bearings⁹, see refs. [12,13]. In general, the predictions for static load performance conditions, including lubricant temperature rise, load capacity and journal eccentricity are in good agreement with the test data. Note that in the references listed, one or more parameters of importance are omitted or not published. Hence, the model implemented best practices to obtain accurate results.

Presently, model predictions for the static and dynamic load performance of a pressure dam journal bearing are compared against exhaustive test data acquired in the laboratory, Jughaiman and Childs [18]. Figure 9 shows a schematic view of the bearing configuration and coordinate

⁹ A set of slides follows this lecture notes – The slides show details and comparisons of (current) model predictions and test data in Refs. [12,13,18]

system. Table 1 details the geometry of the pressure dam bearing, as detailed in Ref. [18]. Please note that Al-Jughaiman's publication (including his M.s. thesis) misses details on the bearing geometry, lubricant inlet and feed conditions. Note that the pressure dam depth to clearance ratio and dam arc length relative to pad arc length follow standard best practices recommended by Nicholas and Allaire[19].

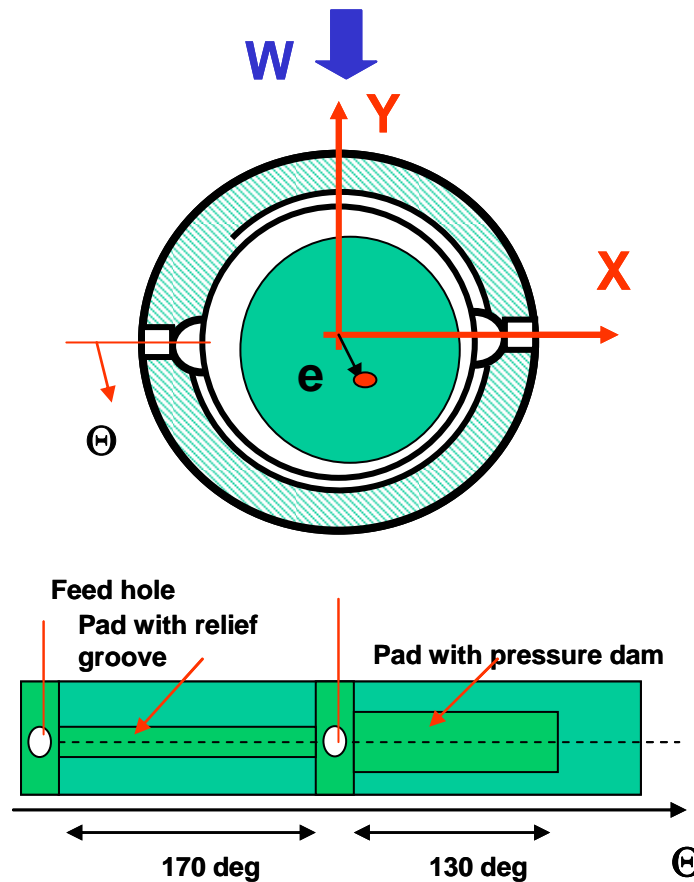

Figure 9. Schematic view of pressure dam bearing with relief groove.

In the experiments, ISO VG 32 lubricant fills the thin film lands of the pressure dam bearing. An air turbine drives the test rigid shaft supported on ball bearings. The test bearing *floats* on the rotating shaft. The tester includes a hydraulic cylinder for static loading, and stinger connections to hydraulic shakers that excite the floating test bearing. The instrumentation includes load cells attached to the shaker stingers, eddy current sensors mounted on the bearing and facing the shaft, and accelerometers attached to the bearing housing. The parameter identification method is

based on frequency domain measurements and extracts the force coefficients from curve fits of the real and imaginary parts of the test system impedances.

The maximum load (W) applied equals 12 kN (2,700 lb) which gives a specific pressure (W/LD) = 13.45 bar (~ 200 psi).

Table 1. Dimensions and operating conditions of pressure dam bearing with relief groove tested by Jughaiman and Childs [18]

| | | | |
|-----------------------|------------------|----------------|-------------------|
| Journal diameter | D | 117.1 | mm |
| Bearing Length | L | 76.2 | mm |
| Radial clearance | c | 0.142 | mm |
| pad arc | | 170 | deg |
| Dam arc length | Θ_D | 130 | deg |
| width (0.75 L) | L_D | 57.1 | mm |
| depth | | 0.4 | mm |
| Reilef groove width | L_R | 19.05 | mm |
| depth | | 0.1 | mm |
| Lubricant | ISO VG 32 | | |
| Density | ρ | 860 | kg/m ³ |
| Specific Heat | C_p | 2000 | J/kg-C |
| Thermal conductivity | κ | 0.13 | W/m-C |
| Viscosity at 45 C | μ | 0.028 | Pa.s |
| Visc-temp coefficient | α | 0.034 | 1/C |
| Inlet oil temperature | | 40-55 ? | C |
| Inlet oil pressure | | N/A | bar |
| Load range | | 0.1-12 | kN |
| Speed range | | 4,6,8,10,12 | krpm |

Closure

Sept 2009: Lecture notes not yet complete. See slide presentation attached.

Nomenclature

| | |
|-------------------|--|
| c | Nominal film (pad) clearance [m] |
| c_m | bearing assembled clearance [m] |
| C_v | Lubricant specific heat [J/kg-K] |
| $C_{\sigma\beta}$ | Bearing damping force coefficients; $\sigma, \beta = X, Y$ [$N\%/m$] |
| D | Journal diameter [m] |

| | |
|--------------------------------|--|
| e_X, e_Y | Journal center eccentric displacements [m] |
| F_X, F_Y | Fluid film bearing reaction forces [N]; |
| $F_S, F_{in}, F_{up},$ | Mass flow rates: supply, inlet to pad and upstream pad [kg/s] |
| h | Pad film thickness, $c - r_p \cos(\Theta - \Theta_p) + e_X \cos(\Theta) + e_Y \sin(\Theta)$ [m] |
| h_X, h_Y | $\cos(\Theta), \sin(\Theta)$ |
| \bar{h}_B, \bar{h}_J | Heat transfer convection coefficients [W/m-K] |
| $K_{\sigma\beta}$ | Bearing stiffness force coefficients; $\sigma, \beta = X, Y$ [N/m] |
| L | Journal bearing axial length [m] |
| $M_{\sigma\beta}$ | Added mass (fluid inertia) coefficients; $\sigma, \beta = X, Y$ [N/m] |
| n_{pe} | Number of nodes per finite element |
| N_{em} | Number of elements in flow domain |
| Q_s | heat flow conducted into bearing and journal surfaces [W/m] |
| P | Film pressure [Pa] |
| P_a | Ambient pressure [Pa] |
| P_{cav} | Lubricant cavitation pressure [Pa] |
| P_S | Supply pressure [Pa] |
| P_0 | Zeroth-order (equilibrium) pressure [Pa] |
| P_σ | First-order complex pressure fields; $\sigma, \beta = X, Y$ [Pa/m] |
| q_η | Volumetric flow rate per unit length [m^2/s] |
| R | $\frac{1}{2} D$. Journal radius, [m] |
| Re_s | $\left(\frac{\rho \omega h^2}{\mu} \right)$. Local squeeze film Reynolds number. |
| r_p | $(c - c_m)$. Pad preload [m] |
| S | Mechanical energy dissipation per unit area [W/m^2] |
| t | Time [s] |
| T | Lubricant mean flow temperature [degK] |
| T_S | Supply temperature [degK] |
| U, W | Lubricant bulk-flow velocities, circumferential and axial [m/s] |
| W_X, W_Y | Components of applied static load, $W = \sqrt{W_X^2 + W_Y^2}$ |
| $(x = R\Theta, y, z)$ | Coordinate system on plane of bearing (starts at $-X$) |
| (X, Y) | Inertial coordinate system |
| $Z_{\sigma\beta}$ | Impedance force coefficients; $(K_{\sigma\beta} - \omega^2 M_{\sigma\beta} + i\omega C_{\sigma\beta})$, $\sigma, \beta = X, Y$ [N/m] |
| α_v | Viscosity-temperature coefficient [1/K] |
| $\Delta e_X, \Delta e_Y$ | Dynamic displacements of journal center [m] |
| Θ | (φ/R) . Circumferential coordinate [rad], |
| $\Theta_l, \Theta_t, \Theta_p$ | Arc pad leading and trailing edges, angle of min. film thickness (offset angle) [rad] |
| μ | $\mu = \mu_S e^{-\alpha_v(T - T_S)}$. Fluid viscosity [Pa-s] |
| Γ^e | Element boundary |
| ρ | Fluid density [kg/m^3] |
| ϕ | Journal attitude angle with respect to static load vector [$^\circ$] |
| $\{\Psi_i\}_{i=1}^{n_{pe}}$ | Finite element shape functions |

| | |
|------------|------------------------------------|
| Ω | Rotor rotating speed, |
| ω | whirl frequency [rad/s] |
| Ω^e | Finite element sub-domain |

Subscripts

| | |
|-----------|---|
| S | Supply condition |
| in | Inlet to pad |
| n,e,w,s | north, east, west and south of control volume |
| N,W,E,S | North, east, west and south nodes |

Superscripts

| | |
|-----|---------|
| e | element |
|-----|---------|

APPENDIX A. MODELS FOR HEAT CONVECTION COEFFICIENTS

Reproduced from Ref.[7]

The Reynolds-Colburn analogy between fluid friction and heat transfer for fully-developed flow determines the heat convection coefficients to accounting for heat flux from the fluid film into the shaft outer surface and from the film into the bearing cartridge. Over the entire laminar/turbulent boundary the *Fanning* friction factor f is:

$$S_t \wp_r^{2/3} = \frac{f}{2} \quad (\text{A.1})$$

where $S_t = \frac{\bar{h}}{\rho C_v U}$ is the *Stanton* number, ρ and C_v are the fluid density and specific heat, and U is a mean flow velocity $\wp_r = \frac{c_p \mu}{\kappa}$ is the *Prandtl* number, and κ and μ are fluid heat conduction coefficient and viscosity, respectively.

From Eq. (A.1), heat convection coefficients \bar{h} for laminar flow are derived from the Nusselt number;

$$Nu = \frac{c \bar{h}}{\kappa} = 3 \wp_r^{1/3} \quad (\text{A.2})$$

while for turbulent flow conditions

$$Nu = \frac{D_{hyd} \bar{h}}{\kappa} = 0.023 Re^{0.8} \wp_r^{0.4} \quad (\text{A.3})$$

where $D_{hyd} = \frac{4 \cdot \text{area}}{\text{wetted perimeter}}$ is a hydraulic diameter.

References

- [1] Boncompain, R., Fillon M., and Frene, J., 1986, "*Analysis of Thermal Effects in Hydrodynamic Bearings*", ASME Journal of Tribology, 108 (2), pp. 219-224.
- [2] Kucinski, B., Fillon M., Pascovici, M., and Frene, J., 2000, "A Transient Thermoelastohydrodynamic Study of Steadily Loaded Plain Journal Bearings using Finite Element Method Analysis", ASME Journal of Tribology, 122, (1), pp. 219-226, 2000.
- [3] Reinhart, F., and Lund, J. W., 1975, "The Influence of Fluid Inertia on the Dynamic Properties of Journal Bearings." ASME J. Lubrication Technology, **97**, pp 154-167.
- [4] Smith, D. L., 1975, "Journal Bearing Dynamic Characteristics-Effect of Inertia of Lubricant, *Proc. Inst. Mech. Engrs.*, Paper No. 21, **179**, Pt.3J, pp 37-44.
- [5] San Andrés, L., and Vance, J., 1987, "Effect of Fluid Inertia on Squeeze Film Damper Forces for Small Amplitude Circular Centered Motions," ASLE Transactions, **30**, No. 1, pp. 69-76.
- [6] San Andrés, L., 2009, *Modern Hydrodynamic Lubrication Theory*, **Notes 10**: Thermohydrodynamic Bulk-Flow Model in Thin Film Lubrication, Texas A&M University, <http://phn.tamu.edu/me626> [Accessed April 2009]
- [7] San Andrés, L., Yang, Z. and Childs, D., 1993, "Thermal Effects in Cryogenic Liquid Annular Seals, I: Theory and Approximate Solutions", ASME Journal of Tribology, **115**, 2, pp. 267-276.
- [8] San Andrés, L., and Kerth, J., 2004, "Thermal Effects on the Performance of Floating Ring Bearings for Turbochargers", Journal of Engineering Tribology, Special Issue on Thermal Effects on Fluid Film Lubrication, IMechE Proceedings Part J, **218**, pp. 437-450.
- [9] San Andrés, L., 2009, *Modern Hydrodynamic Lubrication Theory*, **Notes 6**: Cavitation in Liquid Film Bearings, Texas A&M University, <http://phn.tamu.edu/me626> [Accessed September 2009]
- [10] Pinkus, O., 1990, "Thermal Aspects of Fluid Film Tribology," ASME Press, N.Y.
- [11] Lund, J. W., and E.B. Arwas, 1964, "A Simultaneous Solution of the Lubrication and the Energy Equations for Turbulent Journal Bearing Films," MTI Report N^o 64-TR-31, MTI, Inc., N.Y.
- [12] Ferron, J., Frene, J., and R. Boncompain, 1983, "A Study of the Thermohydrodynamic Performance of a Plain Journal Bearing Comparison between Theory and Experiments", ASME Journal of Tribology, Vol. 105, pp. 422-428,
- [13] Brito, F.P., Miranda, A.S., Bouter, J., and Fillon, M., Frene, J., and R. Boncompain, 2007, "Experimental investigation on the influence of Supply temperature and Supply Pressure on the Performance of a Two-Axial Groove Hydrodynamic Journal Bearing", ASME Journal of Tribology, Vol. 129, pp. 98-105.
- [14] Lund, J., 1987, "Review of the Concept of Dynamic Coefficients for Fluid Film Journal Bearings," *ASME Journal of Tribology*, Vol. 109, pp. 37- 41.
- [15] Klit, P. and Lund, J. W., 1988, "Calculation of the Dynamic Coefficients of a Journal Bearing Using a Variational Approach," *ASME Journal of Tribology*, Vol. 108, pp. 421 - 425.

- [16] Reddy J. N., Gartling, D. K., 2001, *The Finite Element Method in Heat transfer and Fluid Dynamics*, CRC Press, Florida, Chap. 2.
- [17] Patankar, S.V., 1980, *Numerical Heat Transfer and Fluid Flow*, Hemisphere Pubs, N.Y.
- [18] Al-Jughaiman, and Childs, D., 2007, "Static and Dynamic Characteristics for a Pressure-Dam Bearing", ASME Paper GT2007-25577.
- [19] Nicholas, J., and Allaire, P., 1980, "Analysis of Step Journal Bearings-Finite Length and Stability," ASLE Transactions, **22**, pp. 197-207.

Additional (numerical analyses) references

The references below detail numerical analyses for hydrodynamic and hydrostatic liquid and gas bearings, rigid pads and tilting pads. Note that tilting pad bearings show frequency dependent force coefficients. The same holds true for gas bearings

Tilting Pad (liquid) bearings

San Andrés, L., "Turbulent Flow, Flexure-Pivot Hybrid Bearings for Cryogenic Applications," ASME Journal of Tribology, Vol. 118, 1, pp. 190-200, 1996

Gas bearings

San Andrés, L., 2006, "Hybrid Flexure Pivot-Tilting Pad Gas Bearings: Analysis and Experimental Validation," ASME Journal of Tribology, **128**, pp. 551-558.

Delgado, A., L., San Andrés, and J. Justak, 2004, "Analysis of Performance and Rotordynamic Force Coefficients of Brush Seals with Reverse Rotation Ability", [ASME Paper GT 2004-53614](#)

San Andrés, L., and D. Wilde, 2001, "Finite Element Analysis of Gas Bearings for Oil-Free Turbomachinery," *Revue Européenne des Eléments Finis*, **10** (6/7), pp. 769-790.

Zirkelback, N., and L. San Andrés, 1999, "Effect of Frequency Excitation on the Force Coefficients of Spiral Groove Thrust Bearings and Face Gas Seals," ASME Journal of Tribology, 121(4), pp. 853-863.

Foil Gas bearings

San Andrés, L., and Kim, T.H., "Thermohydrodynamic Analysis of Bump Type gas Foil Bearings: A Model Anchored to Test Data" GT2009-59919

San Andrés, L., and Kim, T.H., 2009, "Analysis of Gas Foil Bearings Integrating FE Top Foil Models," *Tribology International*, 42(2009), pp. 111-120.

Kim, T.H., and L. San Andrés, 2008, "Heavily Loaded Gas Foil Bearings: a Model Anchored to Test Data," ASME Journal of Engineering for Gas Turbines and Power, Vol. 130(1), pp. 012504-1-8. ([ASME Paper GT 2005-68486](#)).

Kim, T.H., and L. San Andrés, 2006, "Limits for High Speed Operation of Gas Foil Bearings," ASME Journal of Tribology, 128, pp. 670-673

San Andrés, L., 1995, "Turbulent Flow Foil Bearings for Cryogenic Applications," ASME Journal of Tribology, 117(1), pp. 185-195.

Hydrostatic/hydrodynamic liquid bearings and seals

San Andrés, L., "Thermohydrodynamic Analysis of Fluid Film Bearings for Cryogenic Applications," AIAA Journal of Propulsion and Power, Vol. 11, 5, pp. 964-972, 1995.

Yang, Z., San Andrés, L. and Childs, D., "Thermal Effects in Cryogenic Liquid Annular Seals, II: Numerical Solution and Results", ASME Journal of Tribology, Vol. 115, 2, pp. 277-284, 1993 (ASME Paper 92-TRIB-5).

San Andrés, L., Yang, Z. and Childs, D., "Thermal Effects in Cryogenic Liquid Annular Seals, I: Theory and Approximate Solutions", ASME Journal of Tribology, Vol. 115, 2, pp. 267-276, 1993 (ASME Paper 92-TRIB-4).

San Andrés, L., "Analysis of Turbulent Hydrostatic Bearings with a Barotropic Fluid," ASME Journal of Tribology, Vol. 114, 4, pp. 755-765, 1992.

San Andrés, L., "Fluid Compressibility Effects on the Dynamic Response of Hydrostatic Journal Bearings," WEAR, Vol. 146, pp. 269-283, 1991

San Andrés, L., "Turbulent Hybrid Bearings with Fluid Inertia Effects", ASME Journal of Tribology, Vol. 112, pp. 699-707,

Computational code

Fortran code : complete – including prediction of inertia force coefficients

GUI (Excel interface) – complete

Examples for calibration:

(pressure and temperature fields)

oil 360 deg journal bearing

Dowson et al. (1966)

Ferron, Frene, Boncompain (1983)

Costa, Fillon (2000 2003)

oil two groove journal bearing

Costa, Fillon (2000 2003)

Brito, Fillon (2006, 2007)

Pressure dam bearing

Childs et al (2007, 2008)

Load capacity & force coefficients



Example 1 : Ferron bearing (1983)

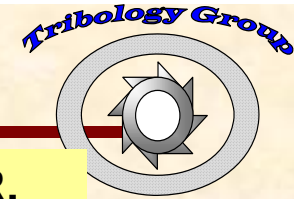

| | | | |
|-----------------------|--------|--|-------------------|
| Journal diameter | D | 100 | mm |
| Bearing Length | L | 80 | mm |
| Radial clearance | c | 0.152 | mm |
| Groove width | | | mm |
| groove arc length | | 18 | deg |
| Lubricant | | | |
| Density | η | 860 | kg/m ³ |
| Specific Heat | C_p | 2000 | J/kg-C |
| Thermal conductivity | η | 0.13 | W/m-C |
| Viscosity at 40 C | η | 0.0277 | Pa.s |
| Visc-temp coefficient | η | 0.034 | 1/C |
| Inlet oil temperature | | 40 | C |
| Inlet oil pressure | | 0.7 | bar |
| Load range | | 1kN-10 kN | |
| Speed range | | 1-4 kRPM | |
| Prandtl No | | 426 | |
| Load No | | 23.98 | |
| Diffusivity | | 7.55814E-08 m ² /s | |
| Sommerfeld # | | $S = \frac{\mu N L D}{W} \left(\frac{R}{C} \right)^2$ | |

Ferron, J., Frene, J., and R. Boncompain, 1983, "A Study of the Thermohydrodynamic Performance of a Plain Journal Bearing Comparison Between Theory and Experiments", ASME Journal of Tribology, Vol. 105, pp. 422-428,

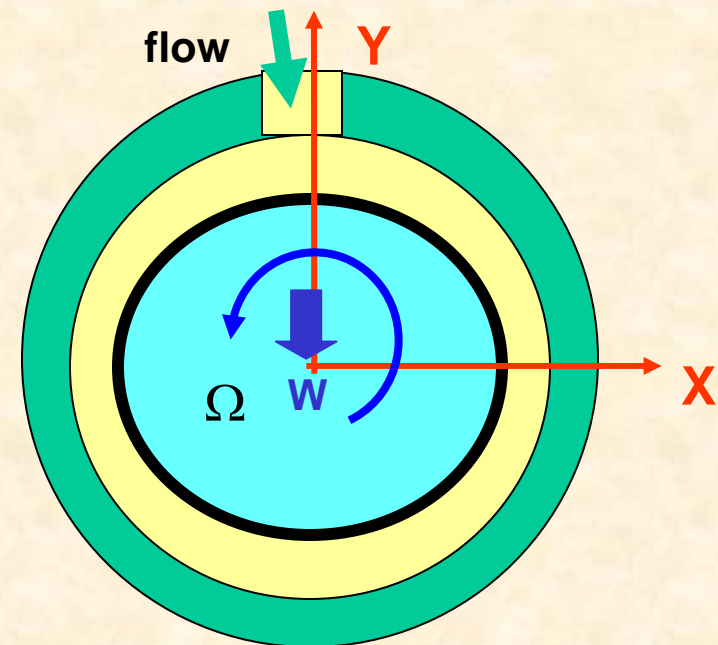



Ferron et al. bearing (1983)

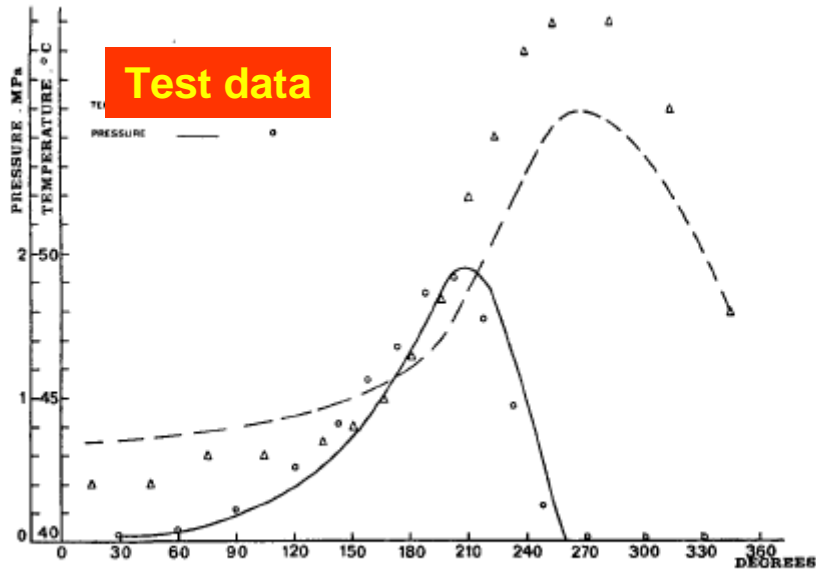
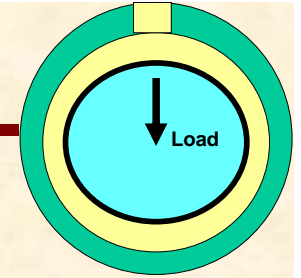

Test data

Fig. 6 Pressure and temperature variations in mid-plane at 4000 rpm and under 6000 N

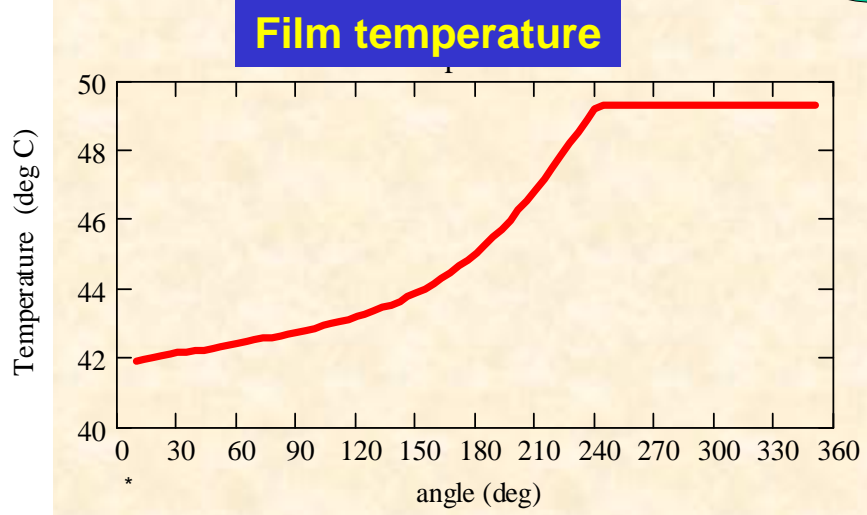

Film temperature

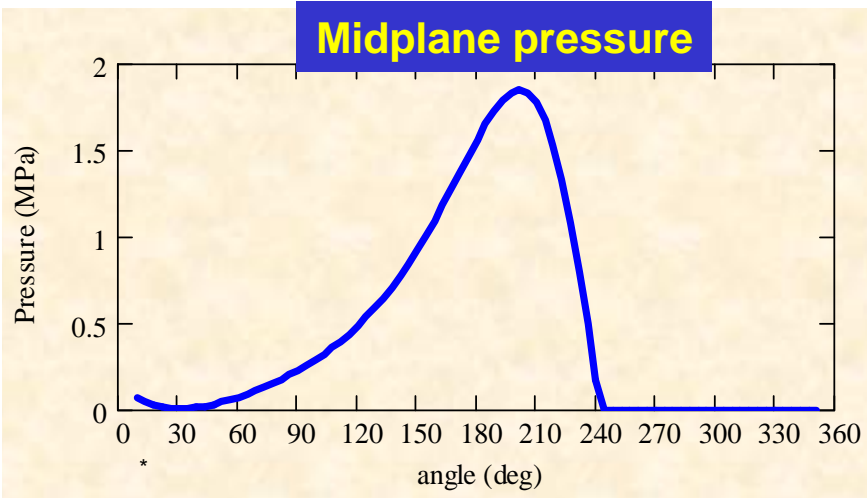

Midplane pressure

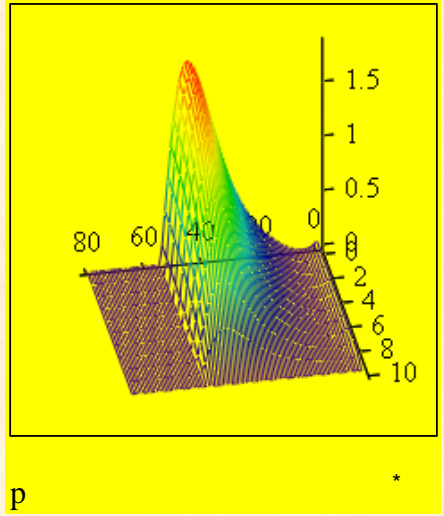

p

Pressure and temperature fields – 4 kRPM, 6 kN



Ferron et al. bearing (1983)

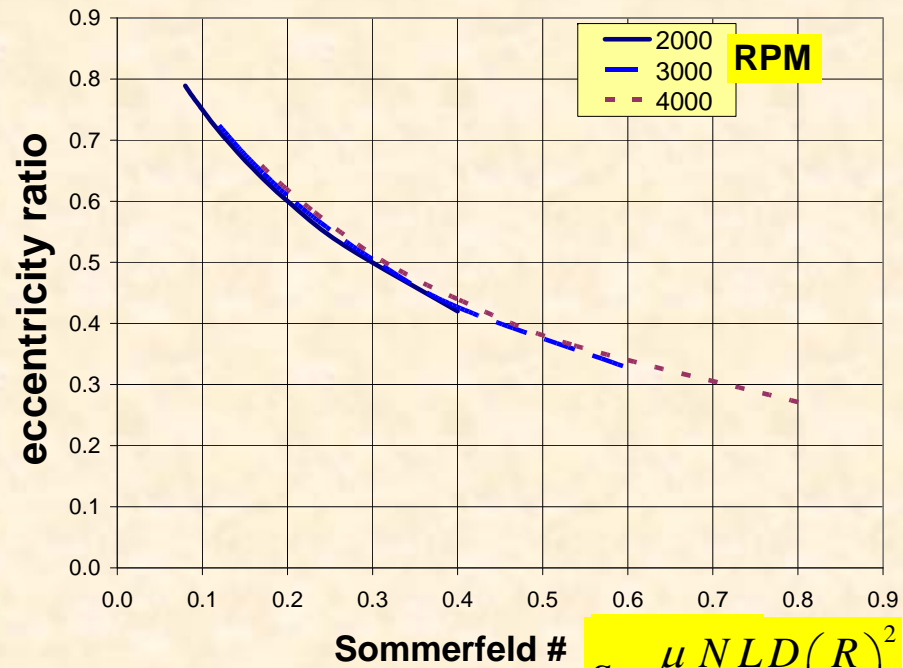
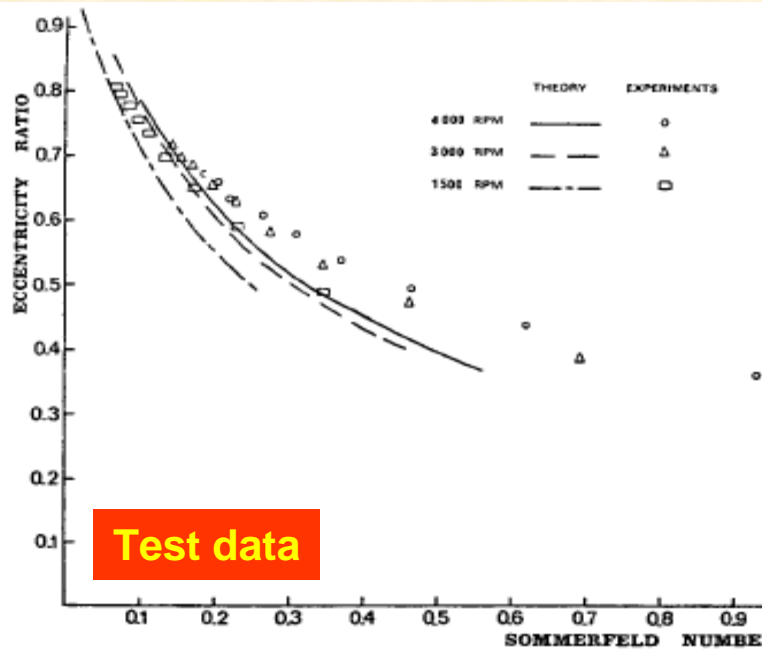
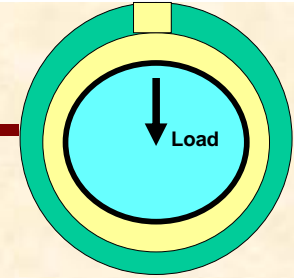

$$S = \frac{\mu NLD}{W} \left(\frac{R}{C} \right)^2$$

Eccentricity ratio (e/c) vs Sommerfeld #



Ferron et al. bearing (1983)

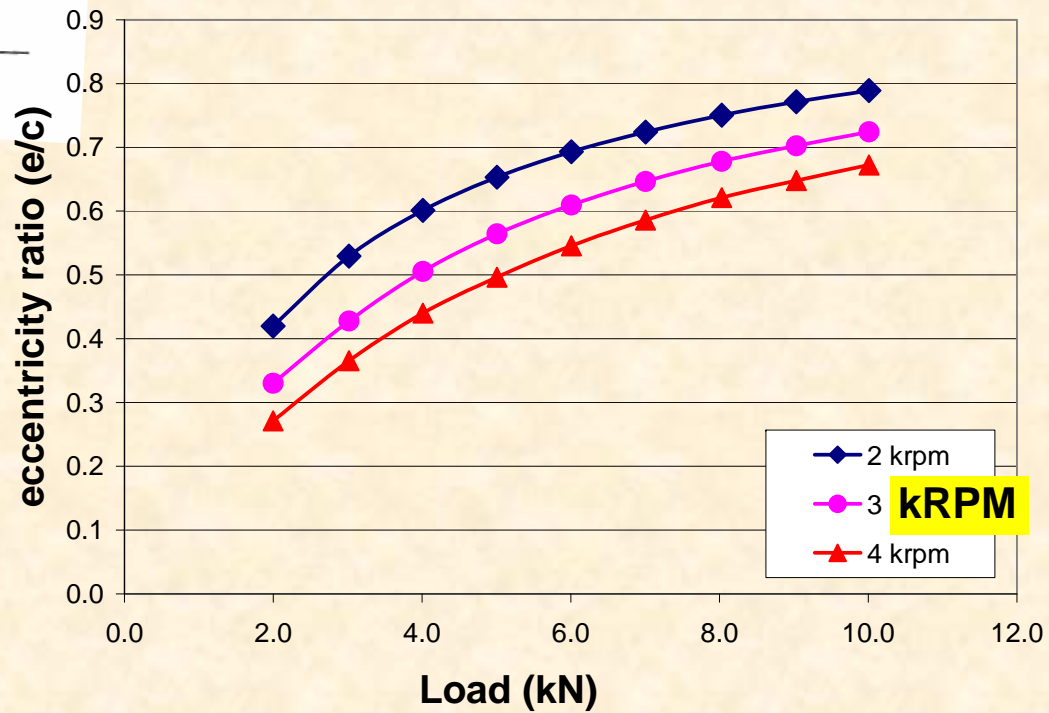
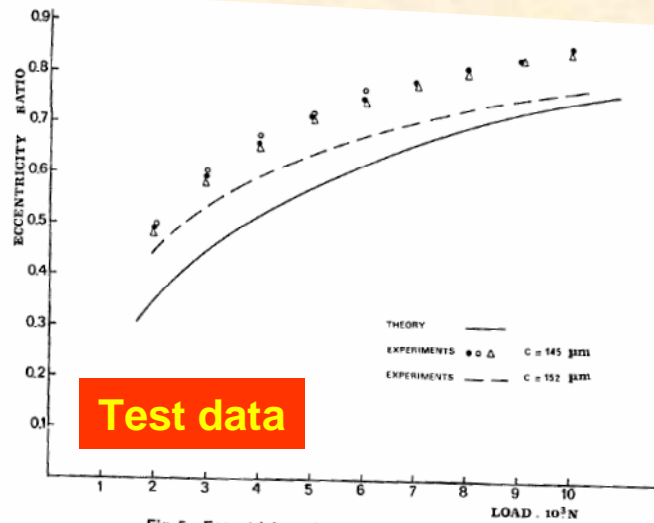
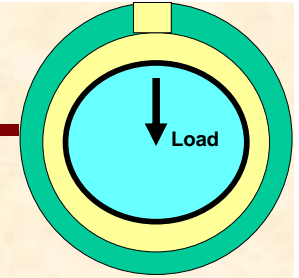

Journal eccentricity (e/c) vs. applied static load



Ferron et al. bearing (1983)

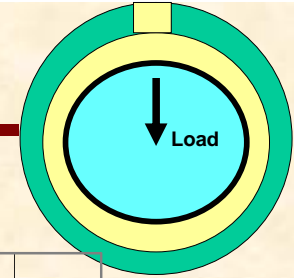

Test data

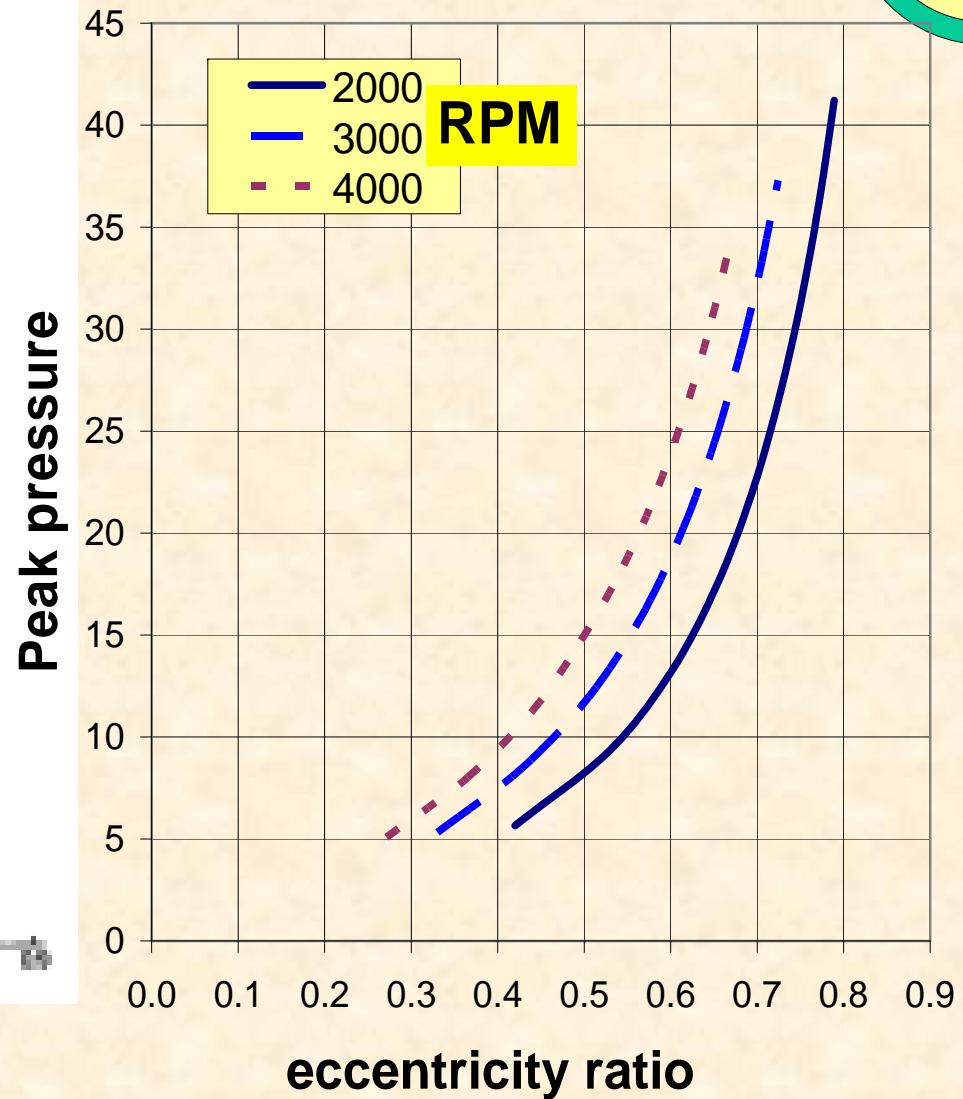
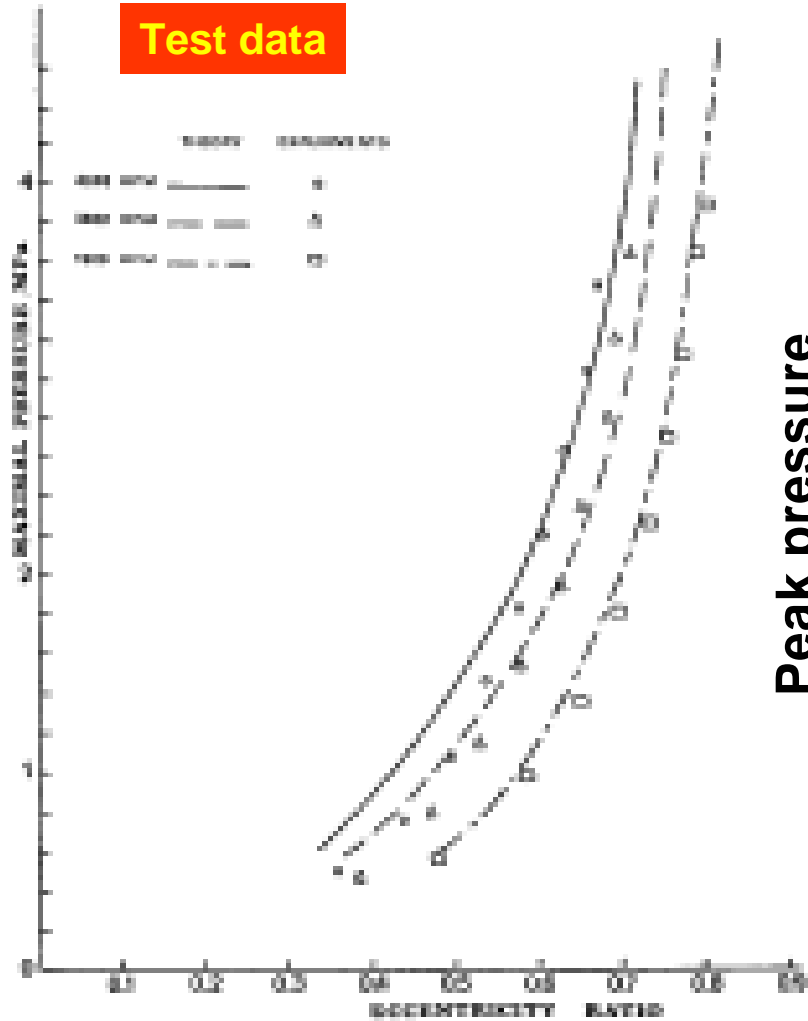

Peak film pressure vs. eccentricity ratio (e/c)



Ferron et al. bearing (1983)

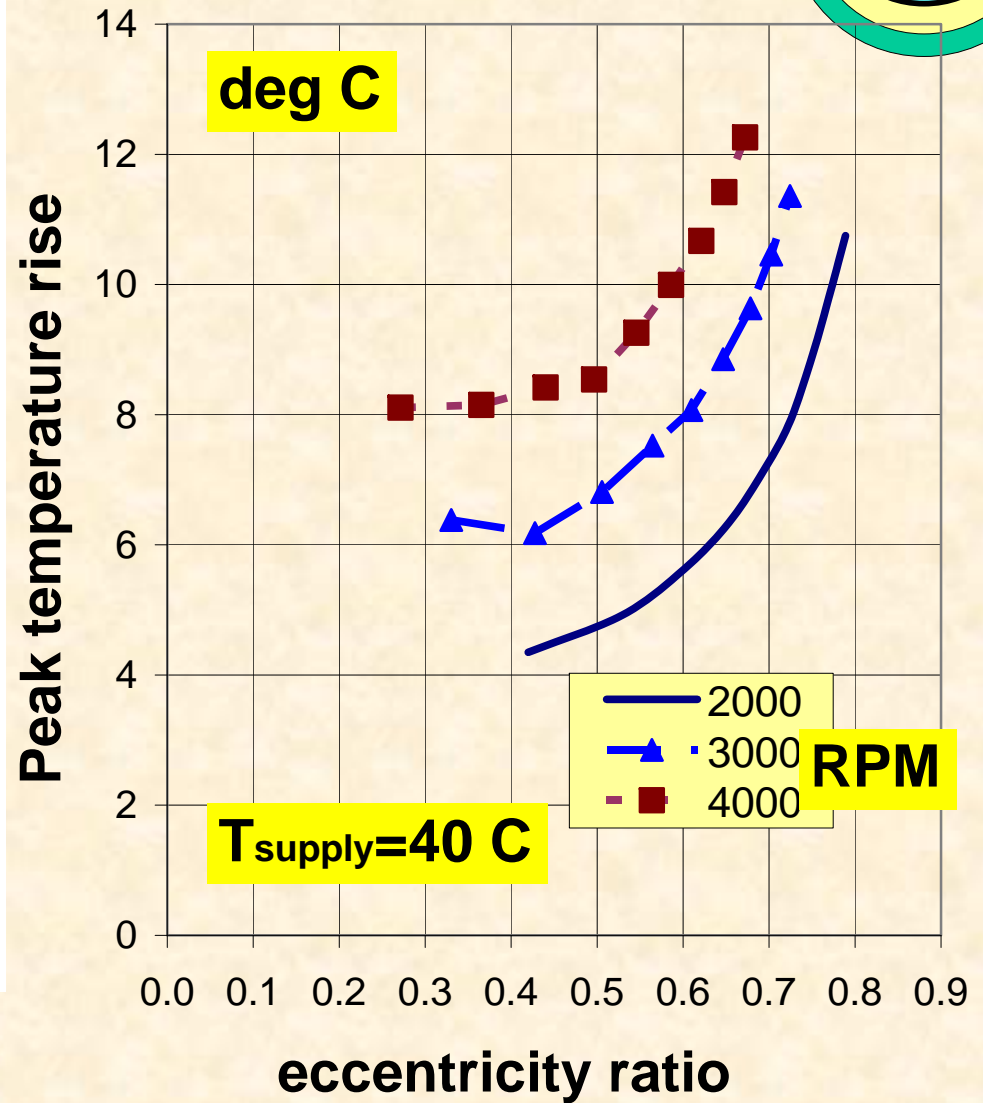
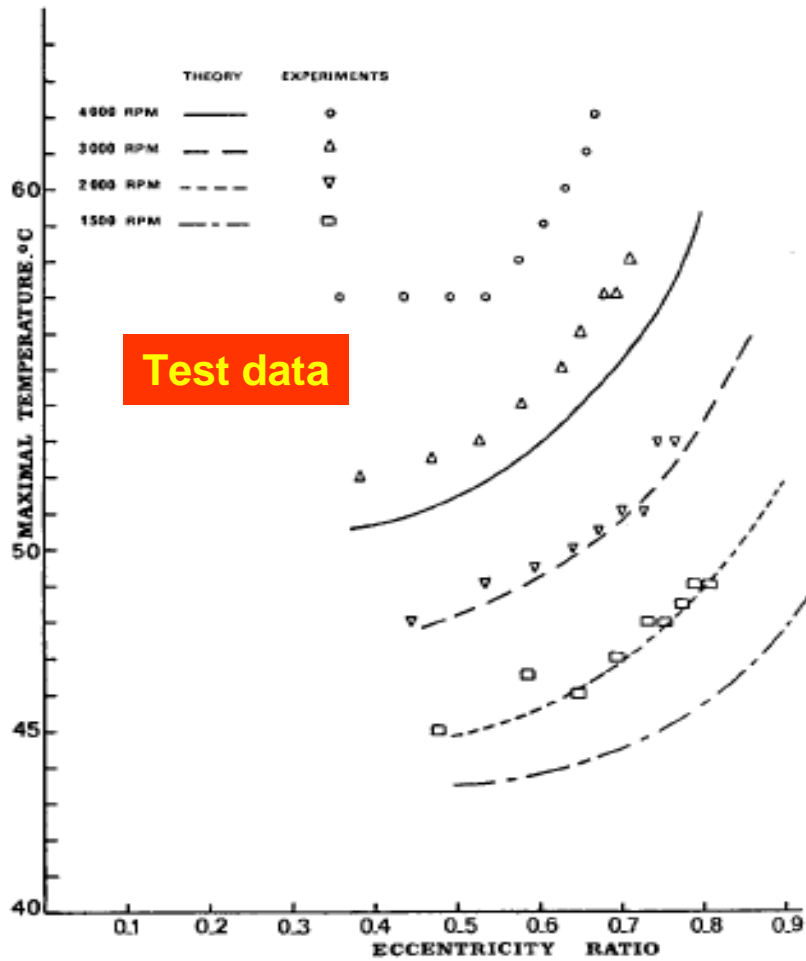
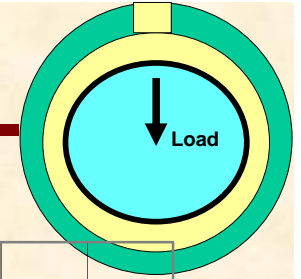

Peak film temperature vs. eccentricity ratio (e/c)



Example 2: two axial groove bearing

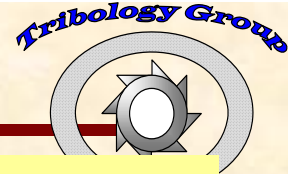

| | | | |
|-----------------------|----------|--------------|-------------------|
| Journal diameter | D | 100 | mm |
| Bearing Length | L | 80 | mm |
| Radial clearance | c | 0.085 | mm |
| preload | r_p | 0 | mm |
| Feed groove width | | 70 | mm |
| Pad arc length | | 162 | deg |
| Lubricant | | | |
| Density | ρ | 870 | kg/m ³ |
| Specific Heat | C_p | 2000 | J/kg-C |
| Thermal conductivity | κ | 0.13 | W/m-C |
| Viscosity at 40 C | μ | 0.0293 | Pa.s |
| Visc-temp coefficient | α | 0.032 | 1/C |
| Inlet oil temperature | | 35,40,50 | C |
| Inlet oil pressure | | 0.7,1.4, 2.1 | bar |
| Load range | | 1kN-10 kN | |
| Speed range | | 1-4 kRPM | |
| Prandtl No | | 451 | |

Brito, F.P., Miranda, A.S., Bouter, J., and Fillon, M., Frene, J., and R. Boncompain, 2007, "Experimental investigation on the influence of Supply temperature and Supply Pressure on the Performance of a Two-Axial Groove Hydrodynamic Journal Bearing", ASME Journal of Tribology, Vol. 129, pp. 98-105,

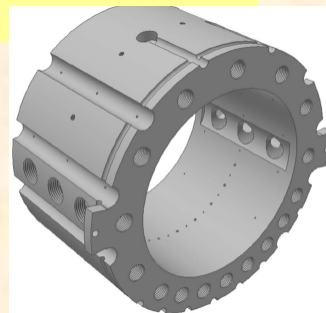
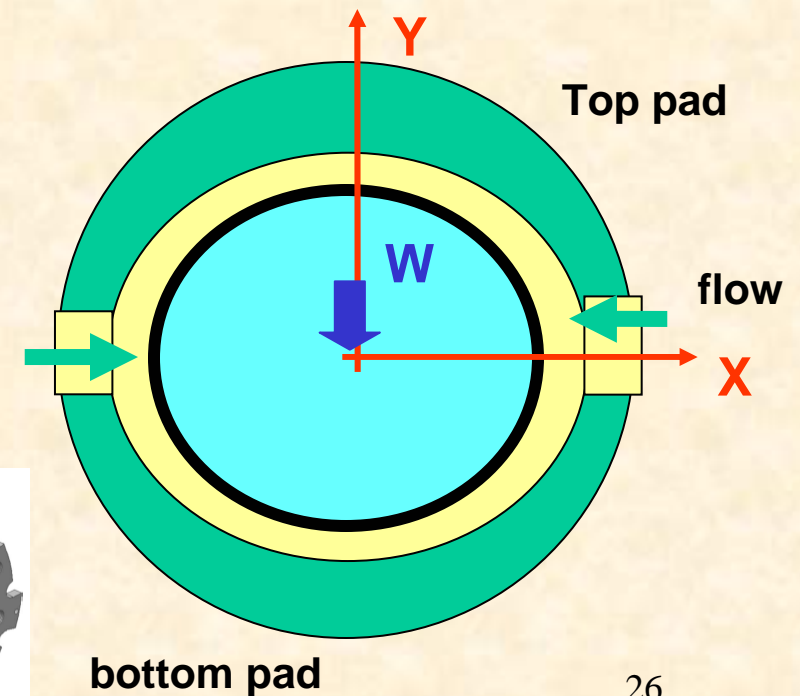



Brito et al. bearing (2007)

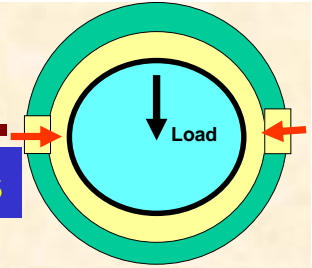

Midplane pressure

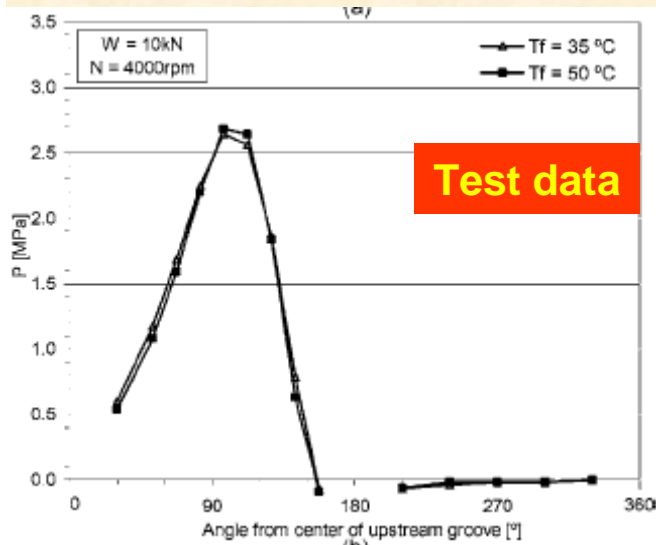

Film temperature

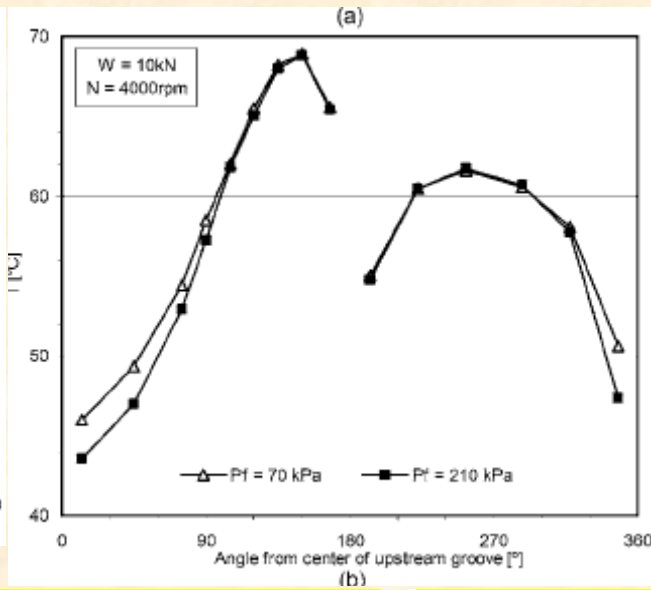

Journal locus

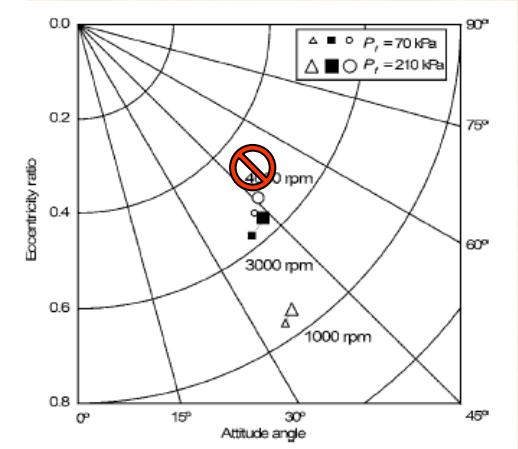

Predictions

e/c=0.43
φ = 56 deg
1.35 kW
3.0 LPM
28 bar max

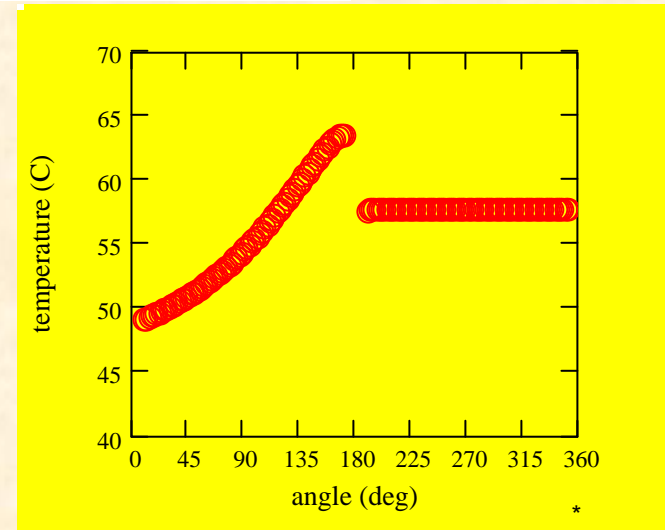
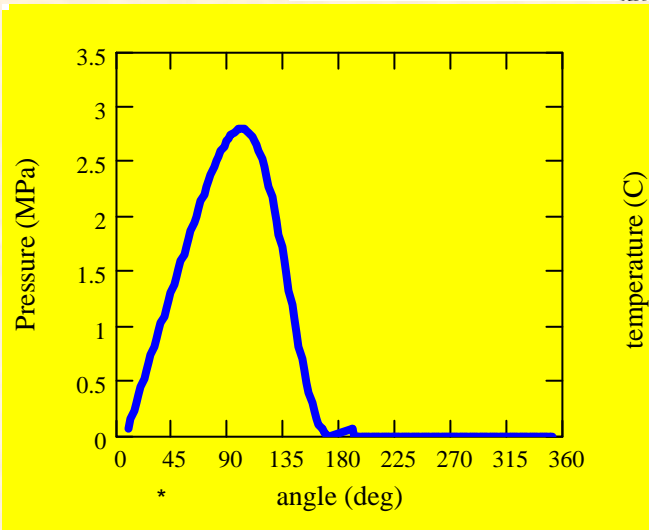

Pressure and temperature fields – 4 kRPM, 10 kN



Example 3 – Pressure dam bearing

| | | | |
|-----------------------|------------------|----------------|-------------------|
| Journal diameter | D | 117.1 | mm |
| Bearing Length | L | 76.2 | mm |
| Radial clearance | c | 0.142 | mm |
| pad arc | | 170 | deg |
| Dam arc length | Θ_D | 130 | deg |
| width (0.75 L) | L_D | 57.1 | mm |
| depth | | 0.4 | mm |
| Reilef groove width | L_R | 19.05 | mm |
| depth | | 0.1 | mm |
| Lubricant | ISO VG 32 | | |
| Density | ρ | 860 | kg/m ³ |
| Specific Heat | C_p | 2000 | J/kg-C |
| Thermal conductivity | κ | 0.13 | W/m-C |
| Viscosity at 45 C | μ | 0.028 | Pa.s |
| Visc-temp coefficient | α | 0.034 | 1/C |
| Inlet oil temperature | | 40-55 ? | C |
| Inlet oil pressure | | N/A | bar |
| Load range | | 0.1-12 | kN |
| Speed range | | 4,6,8,10,12 | krpm |

Al-Jughaiman, and Childs, D., 2007, "Static and Dynamic Characteristics for a Pressure-Dam Bearing", ASME Paper GT2007-25577

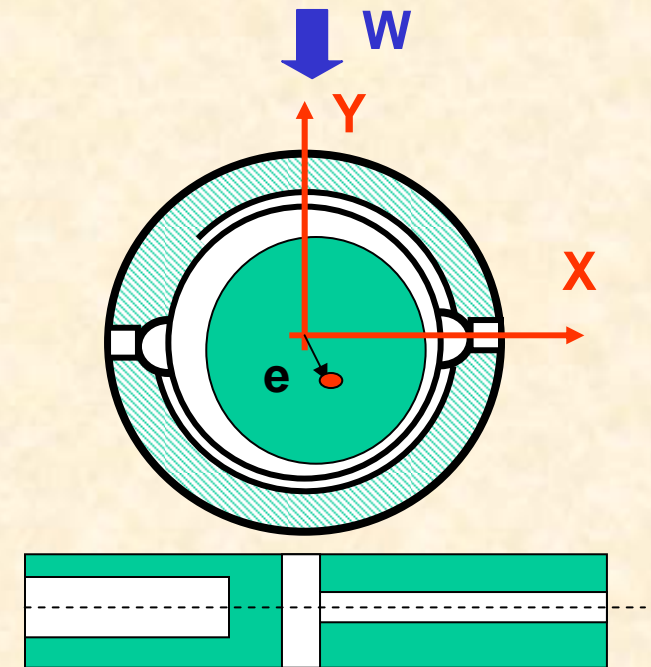

Missing details on bearing geometry, lubricant and feed conditions. Even with test data at hand, not able to reproduce test results in paper. **VERY PECULIAR THERMAL EFFECTS**



Example 3 – Pressure dam bearing

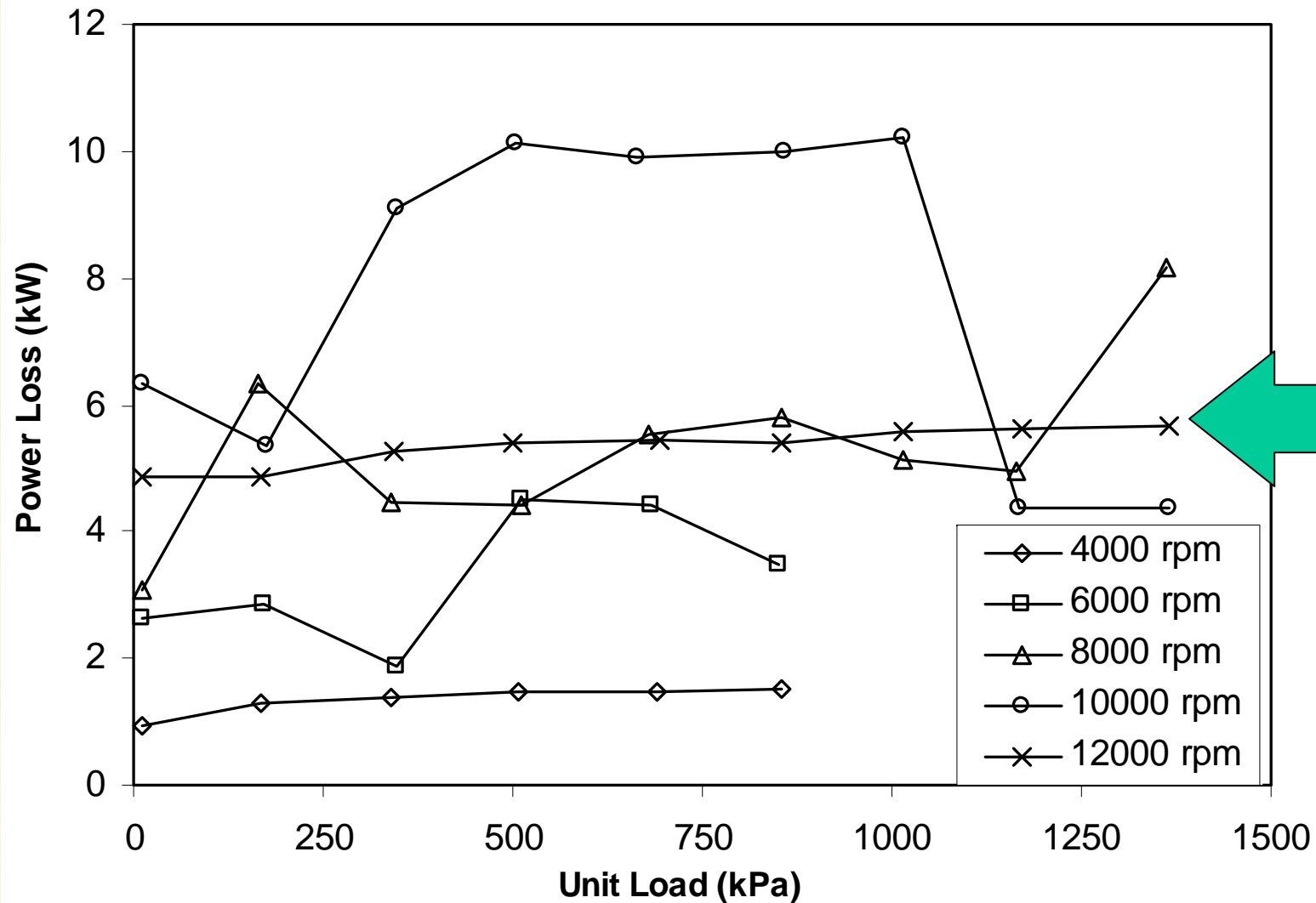



Example 3 – Pressure dam bearing

TAMU Pressure Dam Bearing with relief track

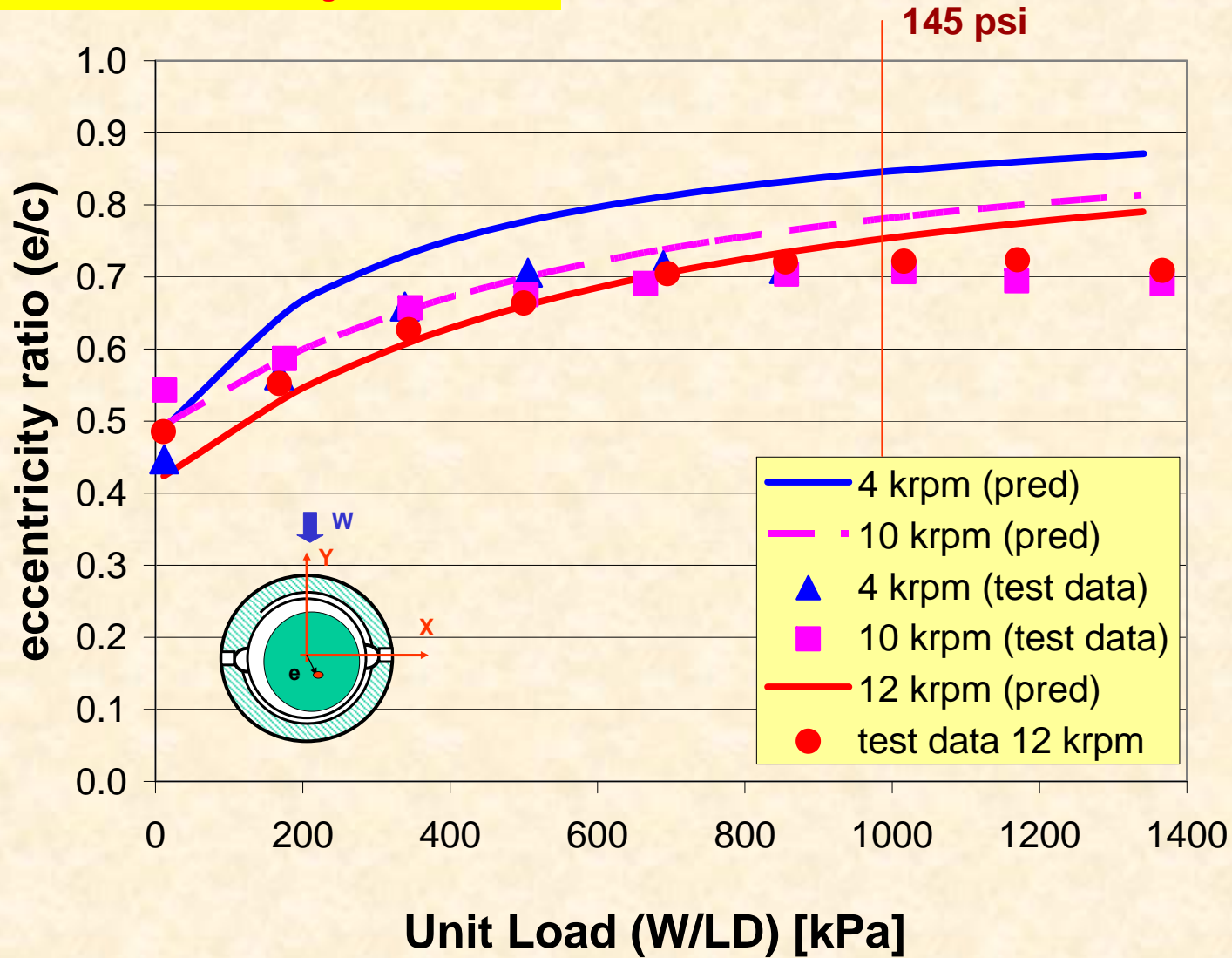

Journal eccentricity vs specific pressure



Example 3 – Pressure dam bearing

TAMU Pressure Dam Bearing

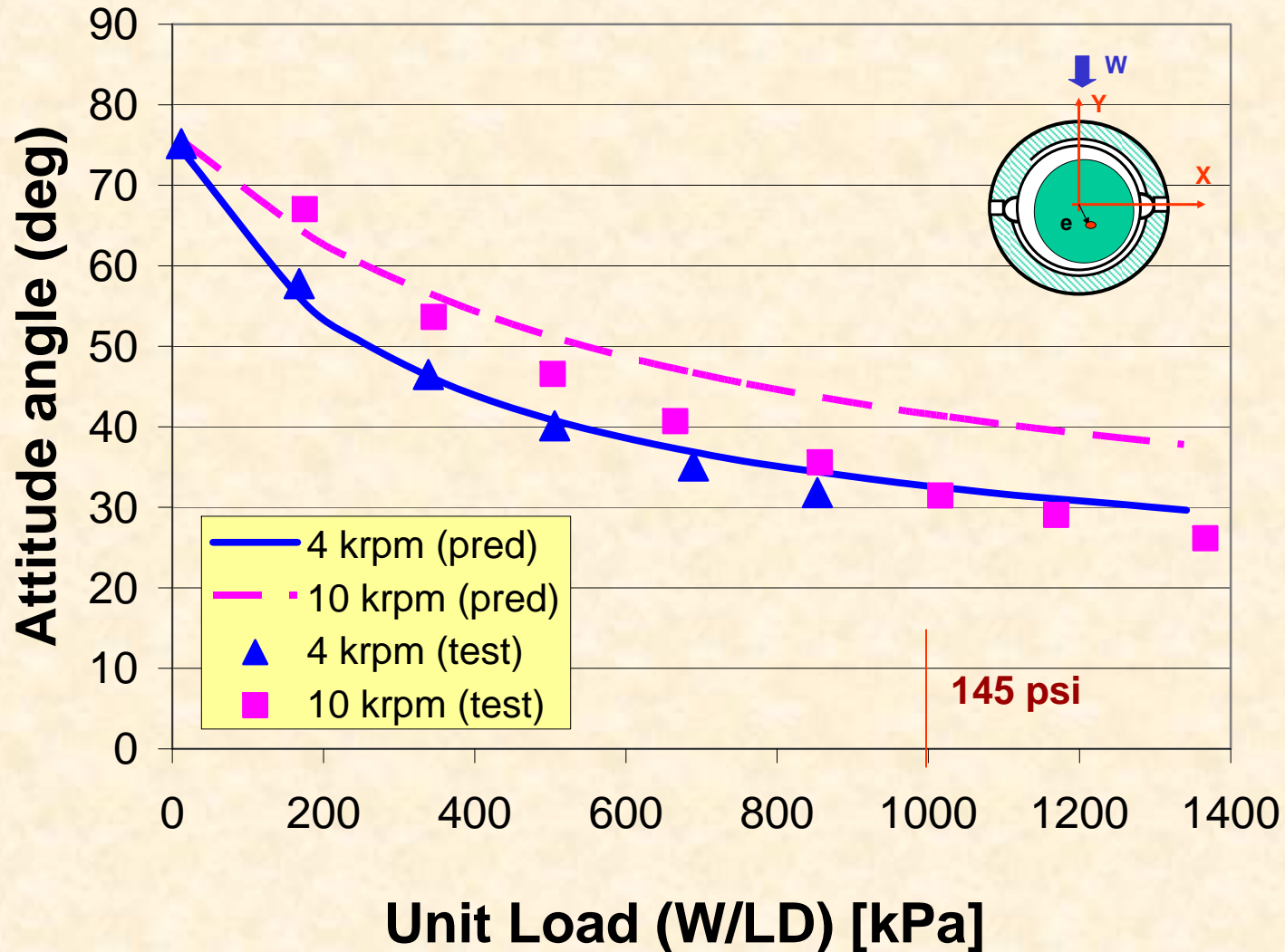

Attitude angle vs specific pressure



Example 3 – Pressure dam bearing

TAMU Pressure Dam Bearing

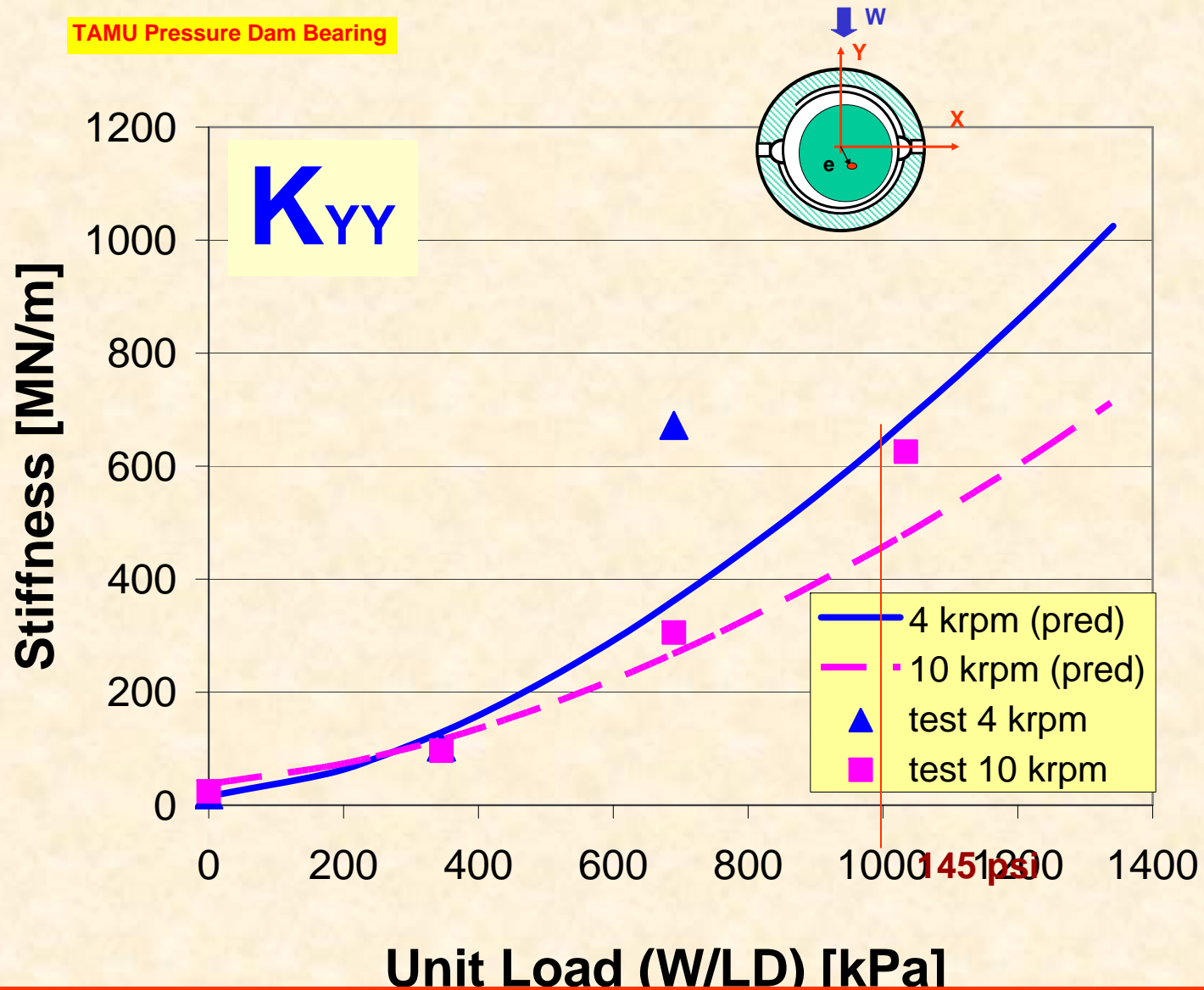

Direct stiffness K_{YY} vs specific pressure



Example 3 – Pressure dam bearing

TAMU Pressure Dam Bearing

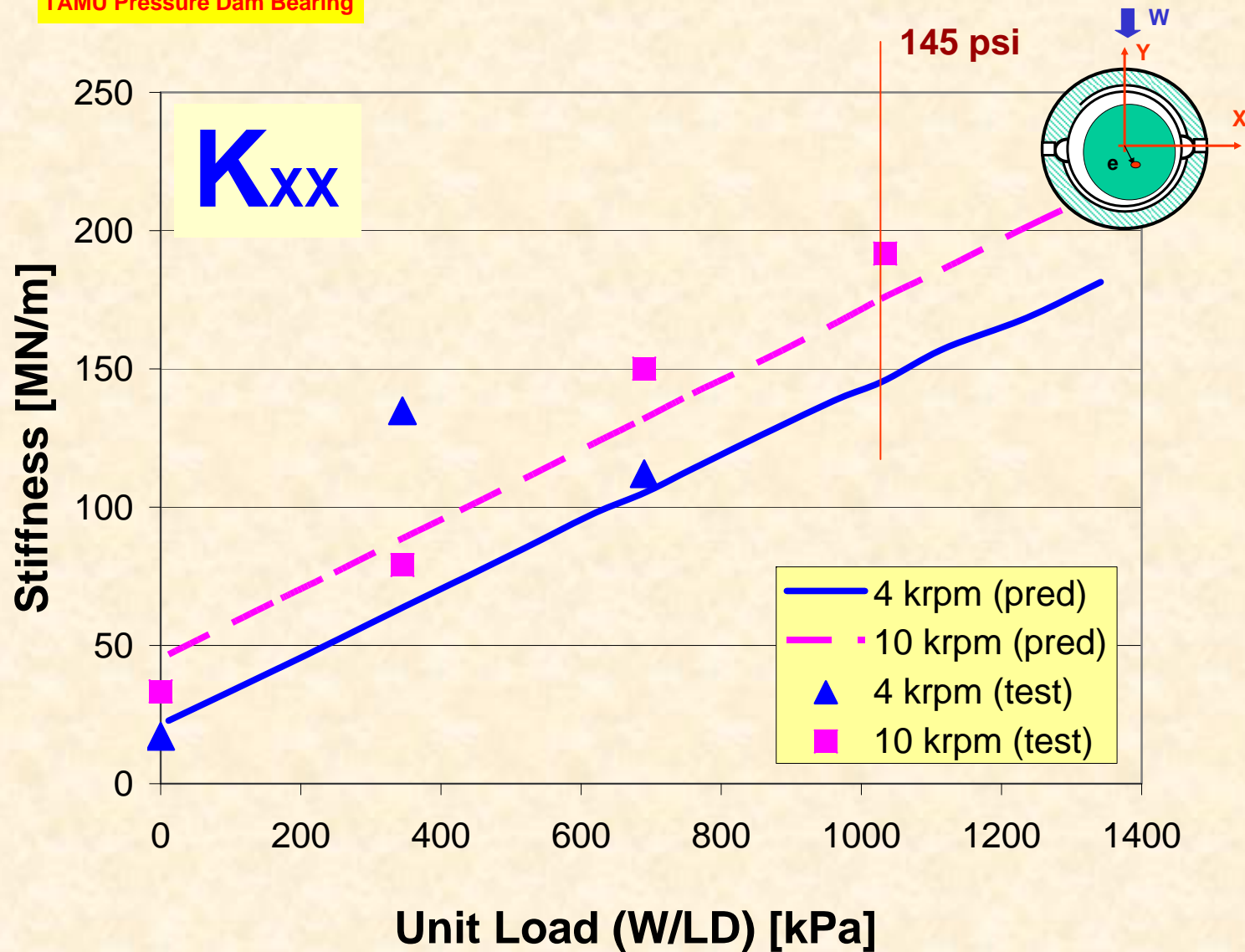

Direct stiffness K_{xx} vs specific pressure



Example 3 – Pressure dam bearing

TAMU Pressure Dam Bearing with relief track

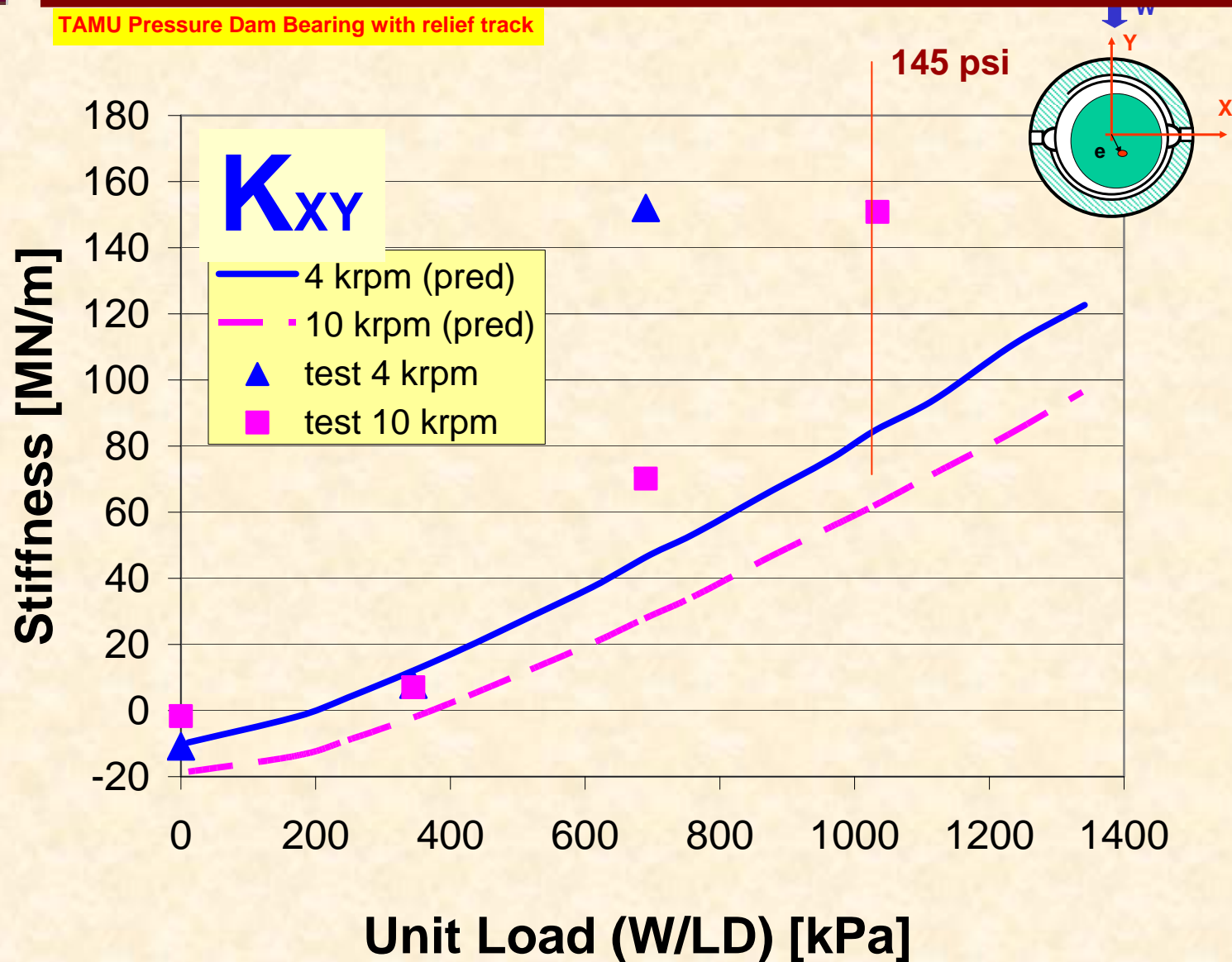

Cross stiffness K_{xy} vs specific pressure



Example 3 – Pressure dam bearing

TAMU Pressure Dam Bearing

Note: prediction changed sign

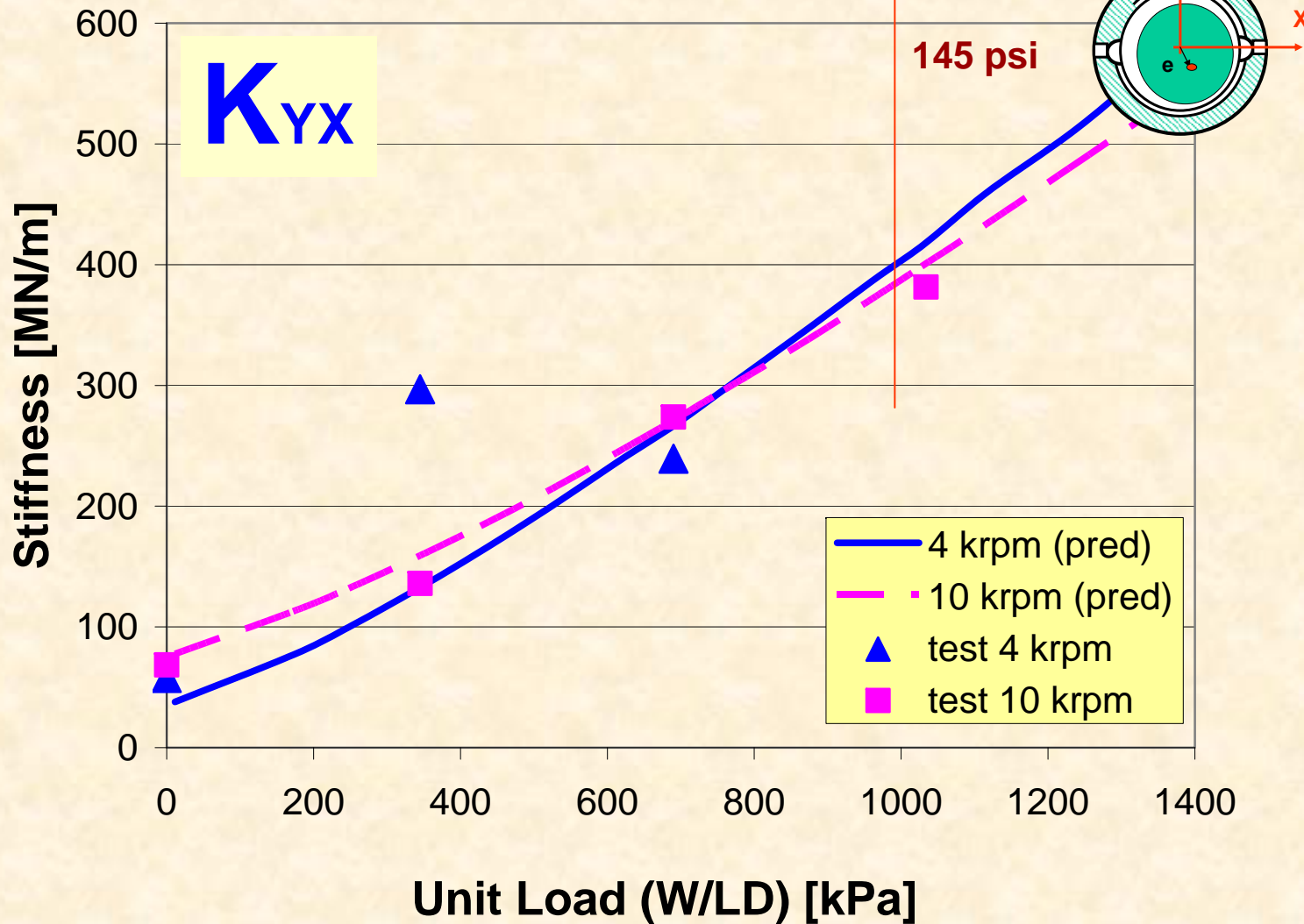

Cross stiffness K_{YX} vs specific pressure



Example 3 – Pressure dam bearing

TAMU Pressure Dam Bearing

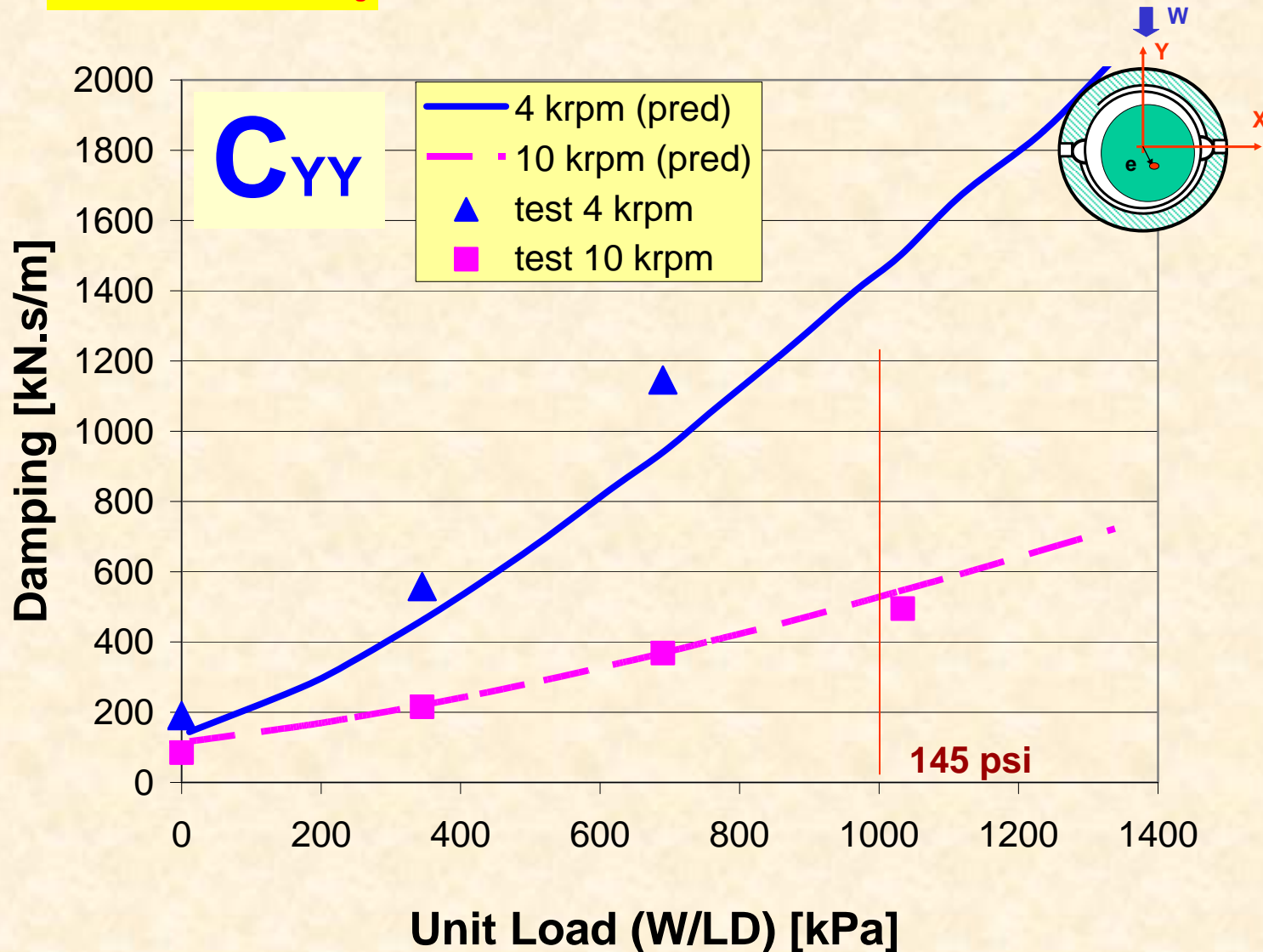

Direct DAMPING C_{YY} vs specific pressure



Example 3 – Pressure dam bearing

TAMU Pressure Dam Bearing

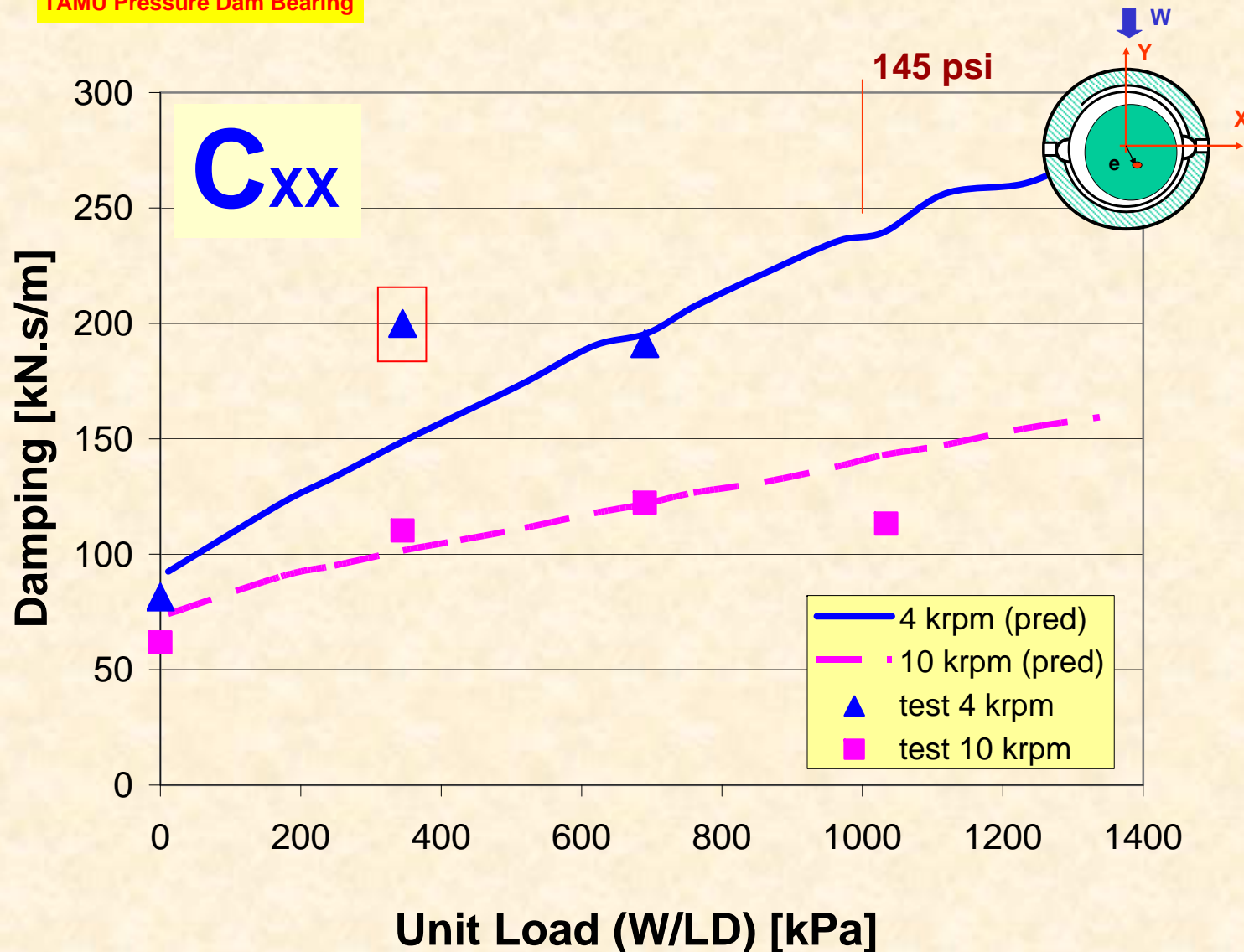

Direct DAMPING C_{xx} vs specific pressure



Example 3 – Pressure dam bearing

TAMU Pressure Dam Bearing

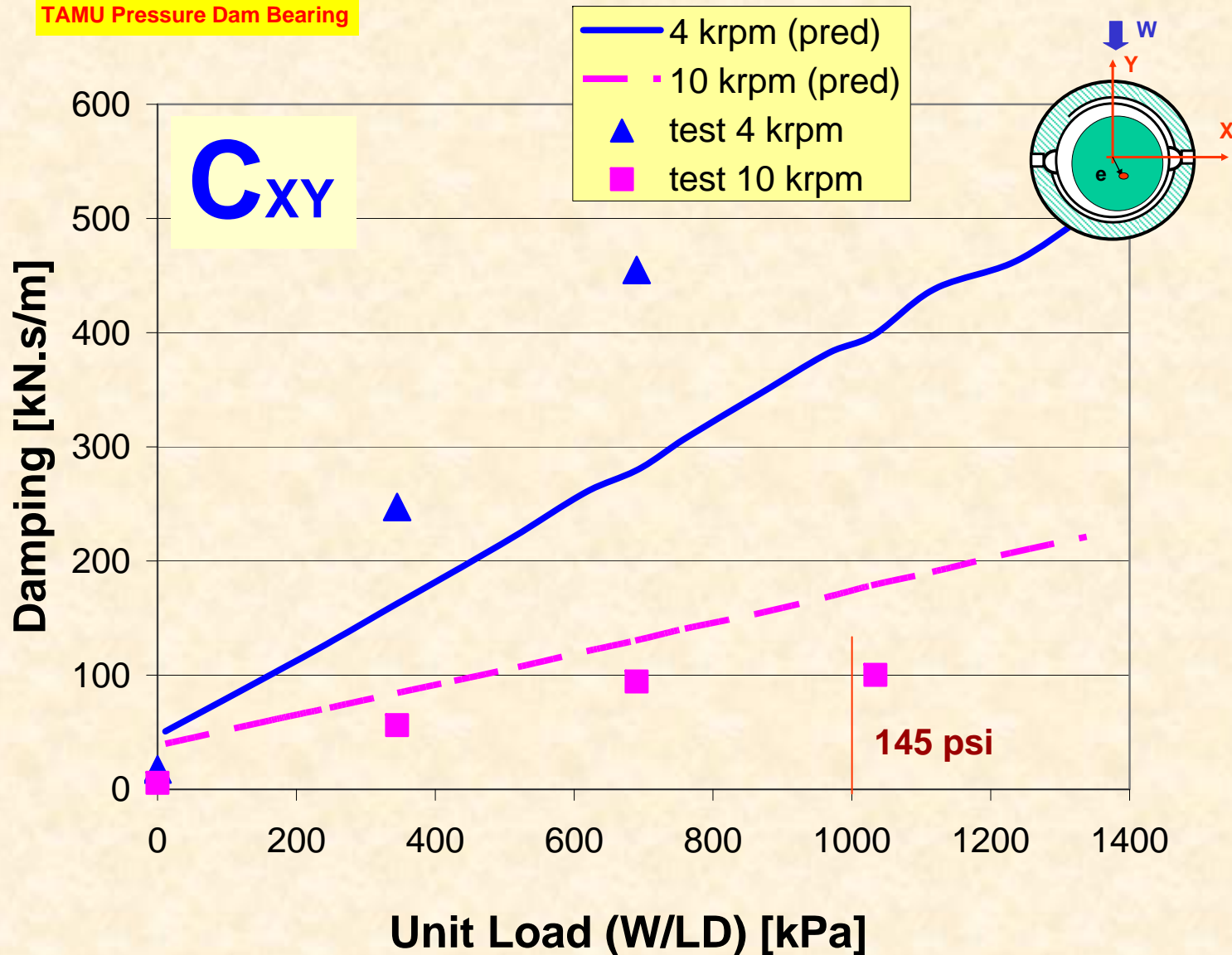

Cross DAMPING C_{xy} vs specific pressure



Example 3 – Pressure dam bearing

TAMU Pressure Dam Bearing

Note: prediction changed sign

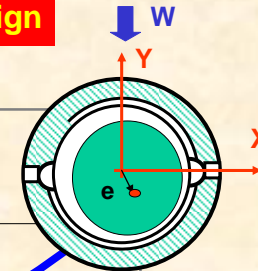
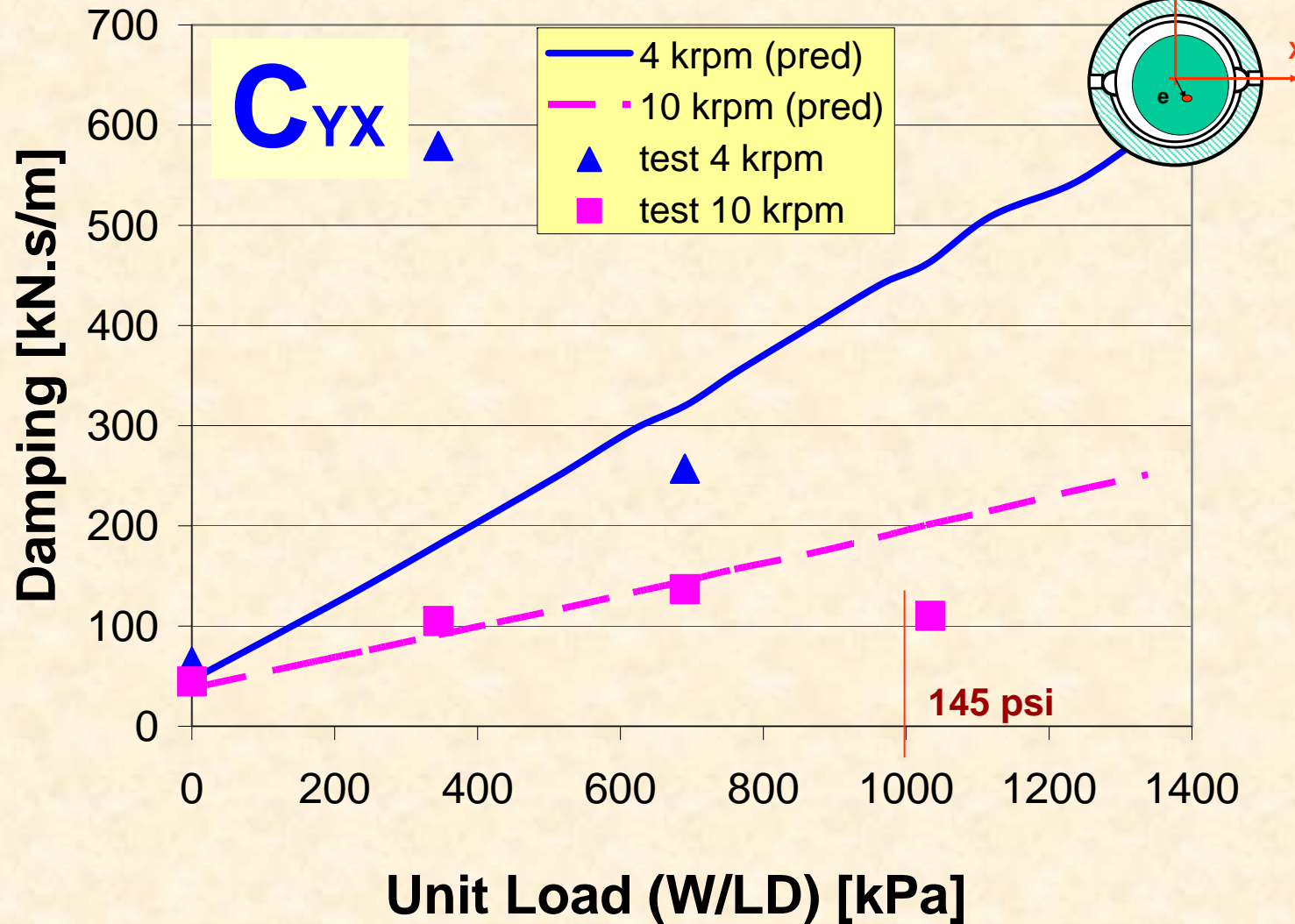

Cross DAMPING C_{yx} vs specific pressure



Example 3 – Pressure dam bearing

TAMU Pressure Dam Bearing

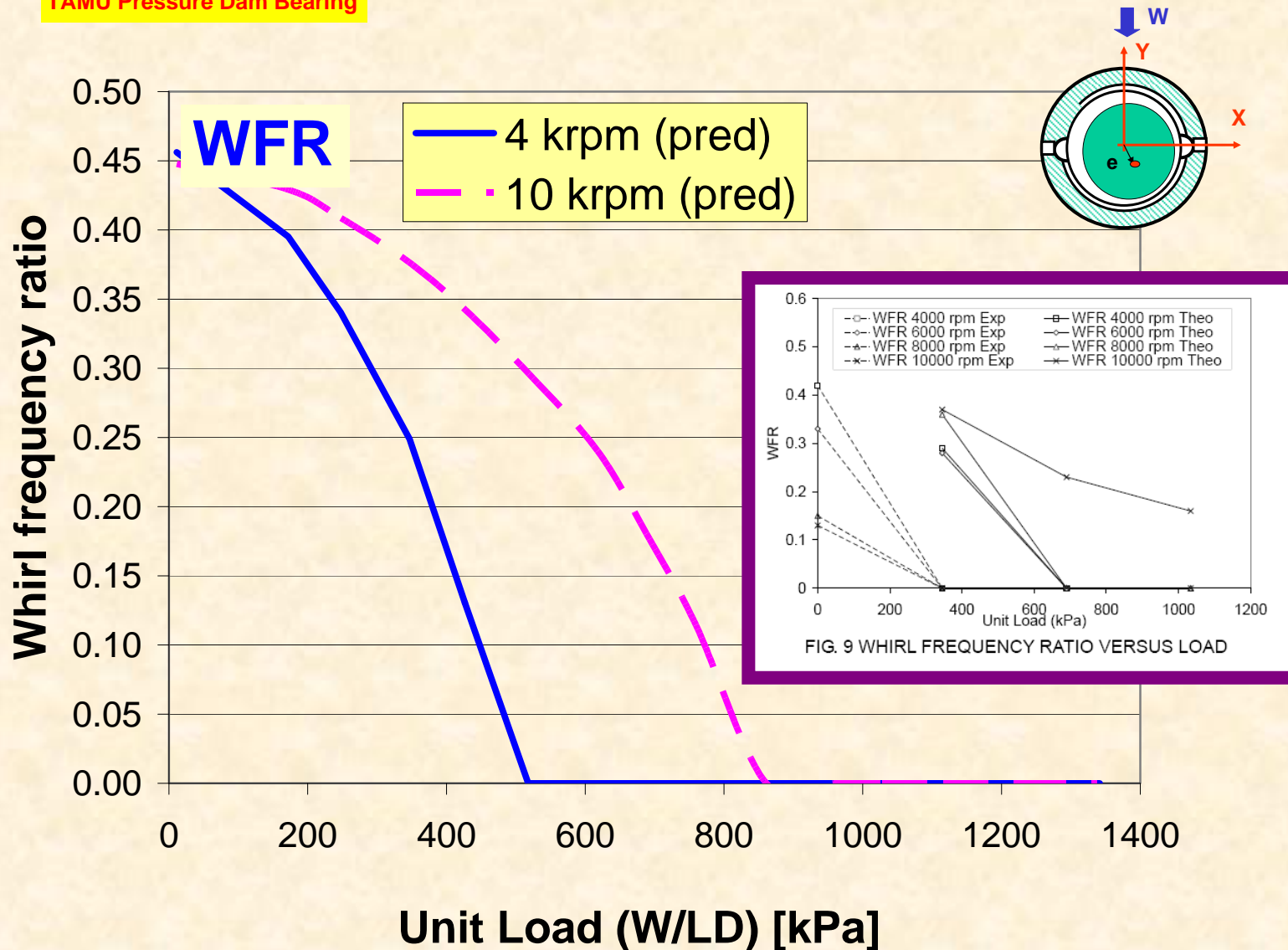

Whirl frequency ratio WFR vs specific pressure



Example 3 – Pressure dam bearing

kg

Inertia coefficients

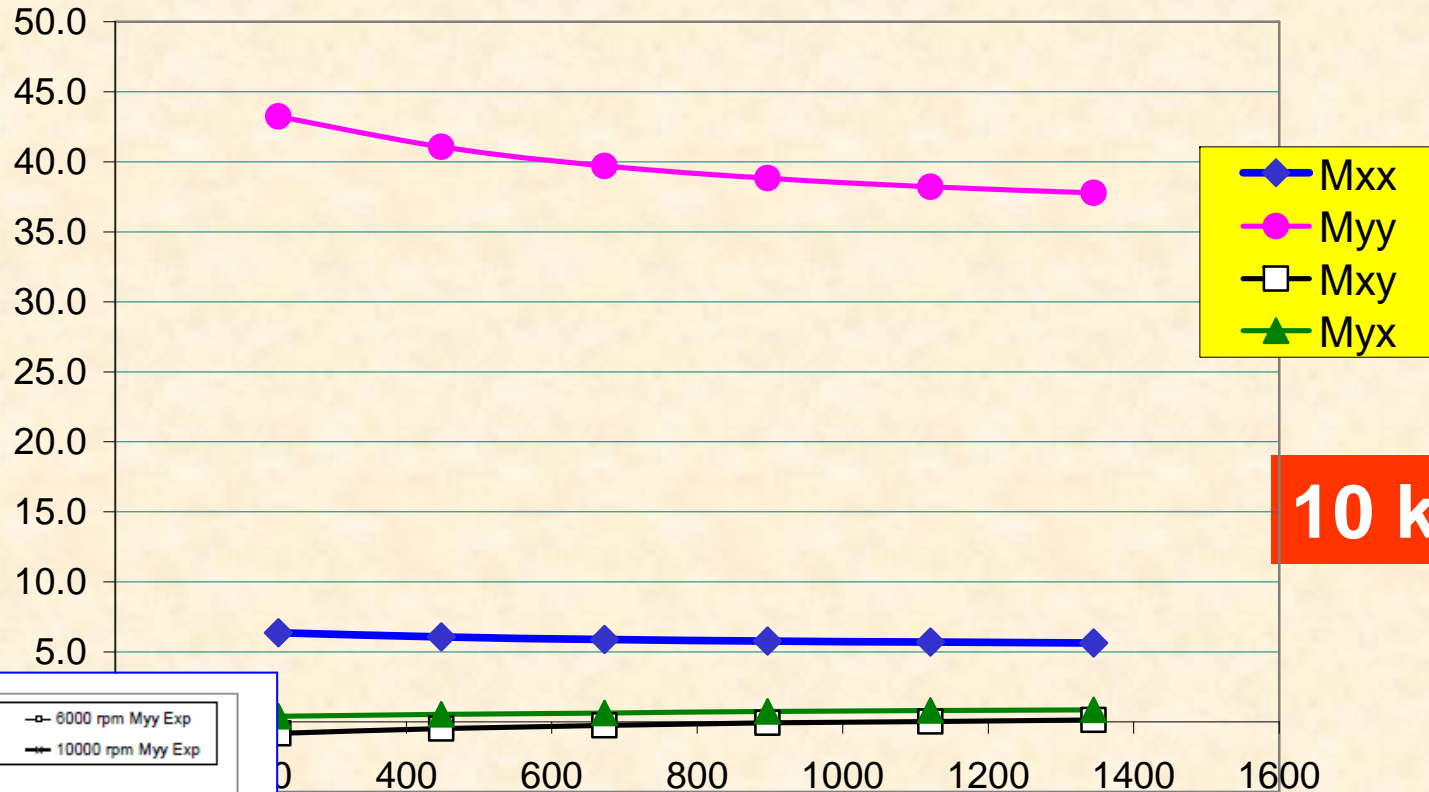

10 krpm

Unit Load [kPa]

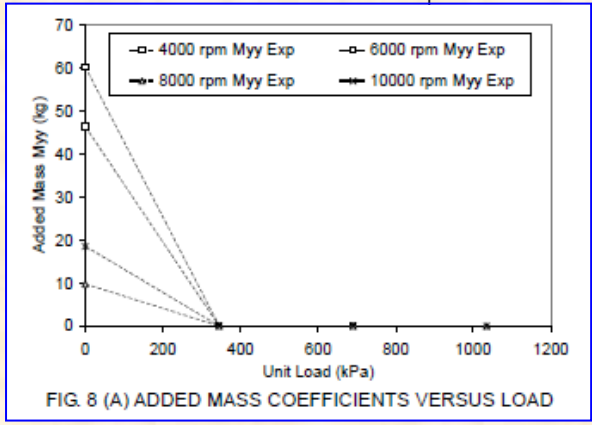

FIG. 8 (A) ADDED MASS COEFFICIENTS VERSUS LOAD

Added Mass Coefficients WFR vs specific pressure