



Pattern Alteration

Principles of Pattern Alteration



Extension Family Development
and Resource Management Specialists

Fit is an important ingredient that makes a garment a wardrobe plus or minus. Standards of good fit are influenced by many things such as the current fashion look, the hang and stretch of the fabric, the amount of ease preferred and figure size and type.

For any seamstress, whether beginning or experienced, the art of fitting requires skill and patience. When this art has been mastered, garments will look better and feel more comfortable.

Once the fabric is cut, however, fitting adjustments are limited to existing darts and seam allowances. Therefore, fitting problems should be solved before the garment is cut by making needed changes in the pattern.

Preserve the altered pattern for later use by fusing nonwoven stabilizer on the pattern's wrong side or redraw the pattern and new markings onto pattern paper. Use dry heat for fusing because steam wrinkles the tissue paper and smears the ink.

Know your measurements

Accurate measurements are the key to good fit. *Measurements should be taken at least every 6 months and/or when weight or the figure has varied significantly.* Take all measurements snugly, but not tightly, over undergarments usually worn. Also, wear shoes similar to those usually worn.

A string tied around the waist and the base of the neck helps establish reference points for measuring. Work in front of a mirror or with a partner to make sure that the tape is straight, parallel to the floor and positioned on the body in the correct locations.

Five measurements are needed to determine pattern size and type. See Extension publication E-373, *Personal Measurement Chart*, for measuring instructions and illustrations.

For best results, top and dress pattern sizes are usually selected according to the best fit between the high bust and full bust measurement. Select the smaller size pattern **if** the full bust measurement is 2 or more inches larger than the high bust measurement. Fit across the upper chest is a wiser choice because of the difficulty of altering the upper chest, neck and shoulder areas.

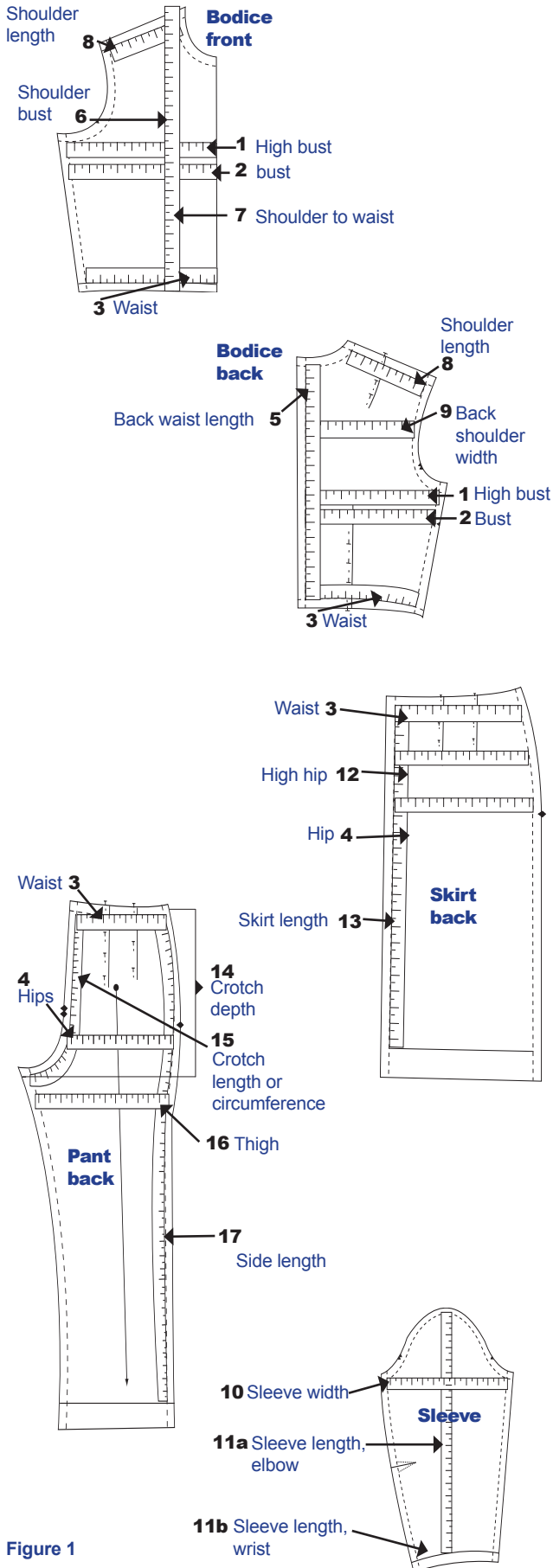

Figure 1

Patterns that have a range of sizes in one category (8-10-12) are made to fit the largest size. When measurements fall between sizes, it is usually best to select the smaller sized pattern.

The 17 measurements listed on the *Personal Measurement Chart* are commonly used in altering garments. These measurements, plus a careful observation of body proportions, shapes and posture, are needed to determine necessary alterations. Prior experience in home sewing or buying ready-to-wear is helpful in pinpointing areas usually needing alterations.

To measure the pattern pieces

Measure each pattern piece at points that correspond with body measurements. For example, if your full hip measurement was taken 10 inches below the waist, measure the pattern's circumference at the same point—10 inches below the waist seamline.

First, smooth the pattern pieces flat. Pin in darts, pleats or gathers as though sewn. Measure from seamline to seamline. Carefully follow the shape of the pattern piece in the area measured. For example, waist and side seamlines often curve, so the tape measure also should curve along the seamline. For a sharp curve such as the crotch, turn the tape measure on its side for ease in following the curve.

The numbered measurements in Figure 1 correspond to the body measurements on the *Personal Measurement Chart*. Use these illustrations as a guide when measuring pattern pieces. Record totals in column IV of the *Personal Measurement Chart*.

Be sure that totals reflect how the pattern will be cut. For example, the bust pattern measurement (number 2) will be taken on all back and front pattern pieces that will be sewn together to make the garment's bustline. For each pattern piece cut double or on the fold, multiply by 2.

To alter the pattern

After measuring the body and adding needed ease, compare this measurement to the pattern's measurement. The difference is the amount of alteration needed, column V of the *Personal Measurement Chart*. The following guidelines are basic to the success of all alterations. Consider each carefully before beginning. These markings are used throughout this publication series to indicate specific alterations.

Using a ruler, *extend grainline markings* the entire length of pattern pieces so that they can be seen clearly throughout altering and cutting. To extend the grainline, lay a ruler along the marked line. Extend the grainline to each seamline or outside edge, keeping the line straight. When pattern pieces are cut apart and then put back together, the *original lengthwise grainline should be maintained whenever possible*.

For garments to hang and fit correctly, the lengthwise grain of the fabric must lie at a right angle to the floor along major parts of the body such as the center front and back unless the pattern is cut on the bias.

If the alteration needed is 1 inch (2.5 cm) or less, alterations often can be made in the existing seam allowances. Exceptions include shoulder length, shoulder slope, upper arm sleeve circumference, rounded shoulders, hollow chest, sway back, bodice front and thigh bulge.

After the pattern is marked and cut apart as instructed, anchor the main pattern section with pins into corkboard or cardboard. Place tissue under any area where needed as described in the instructions. Pivot or position the other part of the pattern the amount needed and pin. Double-check the alteration and then tape pattern and tissue in place.

Make only one alteration at a time. Begin with lengthwise alterations at the shoulder or neck and work down. Finish with the alterations for width, again beginning at the neck and working down. Many problems in side seams, bust area or length disappear when the pattern is correctly fitted in the neck and shoulder area.

If alterations are made correctly, the pattern lies flat. Seam allowances often need to be clipped from the cutting line to, but not through, the seamline. The slashed seam allowance then is lapped or spread slightly to allow the pattern to lie flat (Fig. 2). If the pattern does not lie flat and bubbles or wrinkles, the alteration steps or principles have not been followed correctly.

Make alterations at the source of the problem. For example, when the bust measurement is larger than the pattern, increase the pattern at the fullest part of the bust rather than at the side seams to make the garment fit better.

Do not change the shape of the shoulders, armholes or neckline any more than necessary. These areas are difficult to reshape and alter. Usually, it is better to buy a pattern that fits these areas and then alter other parts of the pattern.

When making alterations, be certain to alter all connecting pattern pieces (facings, etc.) at corresponding points the same amount as the main piece.

Respace the buttonholes if needed so that buttons are placed at stress points such as the bust or waistline.

Lines that are changed or distorted must be returned to a shape similar to the original. When in doubt about which lines to connect, see specific alteration publications for explanations and illustrations.

A French curve is used to redraw curved areas such as waistlines. Move the French curve on the lines to be redrawn until the lines connect smoothly and are a shape similar to the original (Fig. 3).

A straightedge, preferably a see-through 18-inch ruler, is used to redraw straight lines (Fig. 3).

A T-square is helpful in drawing right angles. To find a line at right angles to the grainline, center front or center back without a T-square, fold that line on top of itself and crease where needed. The crease is at a right angle (Fig. 4).

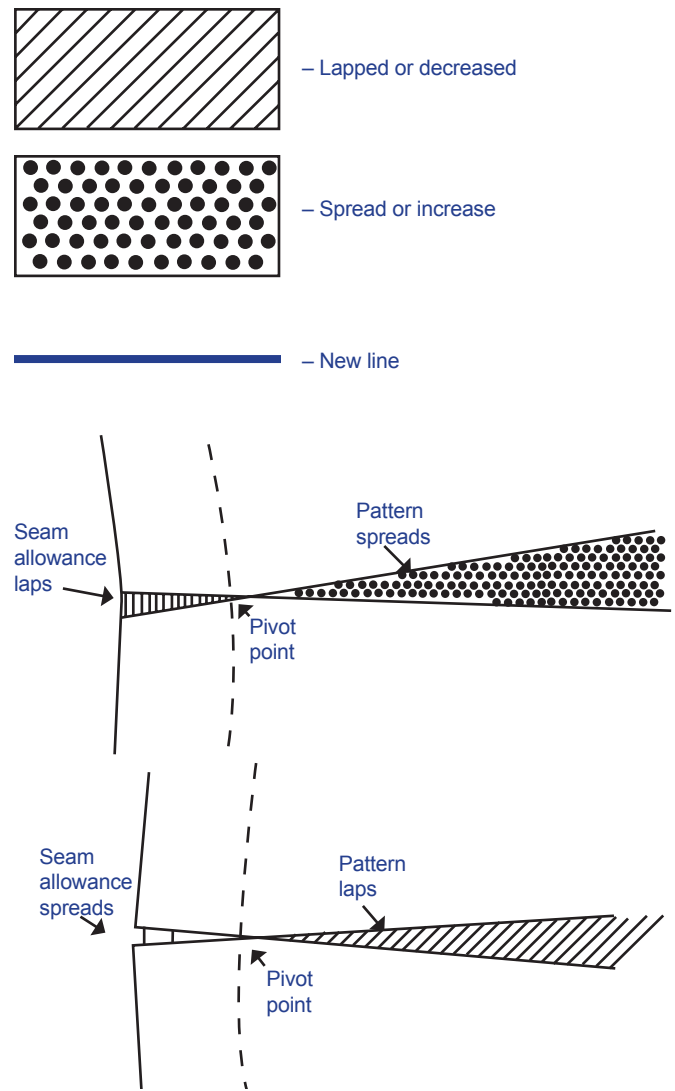

Figure 2

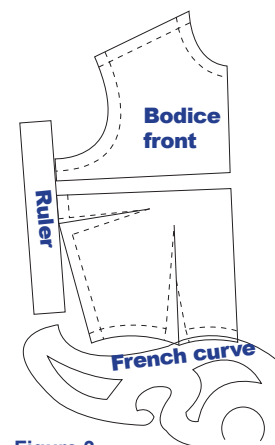

Figure 3

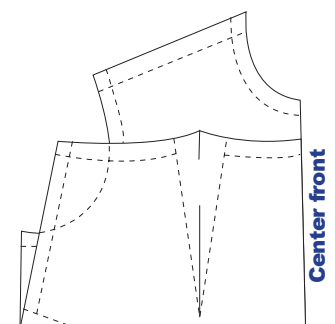

Figure 4. Crease is at a right angle to center front

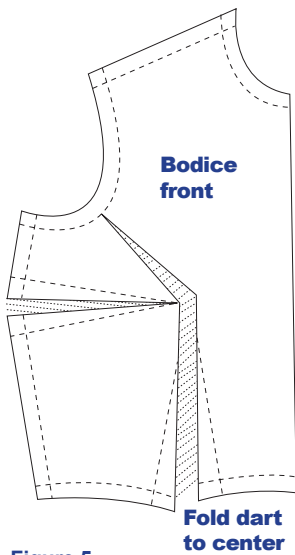

Figure 5

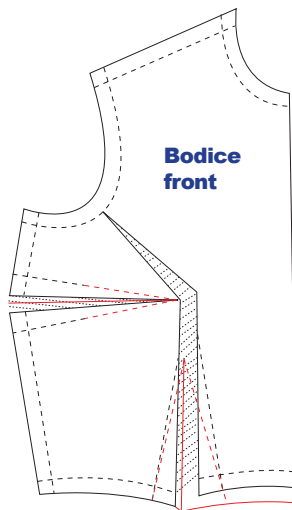

Figure 6

When redrawing lines that cross darts, first fold the dart in the direction it will lie when sewn in the garment. Vertical darts press toward the center of the garment, while horizontal darts press downward (Fig. 5). With darts folded in place, cut along the garment's cutting line or prick holes with pins to establish the new shape (Fig. 6).

Check the altered fit

If you question the way your pattern will fit, make the garment in an inexpensive fabric or pattern-tracing product before cutting out the fashion fabric. This is especially important if you have made several changes in the pattern or are unsure of the adjustments made.

To check the fit, baste only the basic parts of the garment together. Have someone help you check the fit of the garment or stand in front of a full-length mirror. Use the following checklist to help you determine if further alterations or minor fitting is needed for a good fit.

- Lengthwise grainlines, side seams, center front and center back seams hang straight or at right angles to the floor.
- Crosswise grainlines are parallel to floor.
- Adequate wearing ease is available for sitting, moving and bending.
- Armhole seams curve smoothly over the end of shoulder.
- Darts point to the fullest part of the curve.
- Shoulder seam length comes to end of shoulders.
- Sleeves are comfortable with no wrinkles.
- Hipline fits smoothly.
- Hemline is even.
- Pant legs hang smoothly and do not restrict any part of the legs.
- Crotch depth is right, neither too low and baggy nor too tight and binding.
- Pants hang smoothly from the waist. The waistband fits the body comfortably and stays in place when bending and sitting.
- Pants have no pulls or excess fabric across the front or back crotch level.
- The length of the garment is becoming.

Becky Culp wrote the original manuscript for this publication.

Produced by AgriLife Communications, The Texas A&M System
Extension publications can be found on the Web at: <http://agrilifebookstore.org>

Visit the Texas AgriLife Extension Service at <http://agrilifeextension.tamu.edu>

Educational programs of the Texas AgriLife Extension Service are open to all people without regard to race, color, sex, disability, religion, age, or national origin.

Issued in furtherance of Cooperative Extension Work in Agriculture and Home Economics, Acts of Congress of May 8, 1914, as amended, and June 30, 1914, in cooperation with the United States Department of Agriculture. Edward G. Smith, Director, Texas AgriLife Extension Service, The Texas A&M System.

Revised