

## CONTINUOUS COMMISSIONING<sup>®</sup> OF A MODERN CENTRAL UTILITY PLANT

Qiang Chen  
Malcolm Verdict, C.E.M.

Chen Xu  
Dan Turner, Ph.D., P.E.  
Energy Systems Laboratory  
Texas A&M University System  
College Station, TX

Jijun Zhou, P.E.  
Song Deng, P.E.

Brian Birch, P.E.  
IBM Real Estate and Site Operations  
Austin, TX

### KEYWORD

Continuous Commissioning, Central Utility Plant, Energy Management and Conservation, Thermal Distribution System, Computer Room Air Conditioning Unit

### ABSTRACT

Continuous Commissioning<sup>®1</sup> (CC) technology has been proven to be highly cost-effective in reducing building and plant energy consumptions. The case study facility has a seven-building campus with about one million sq.ft. building space, mostly offices and computer server rooms. The chilled water (CHW) for space cooling is provided by a modern central utility plant (CUP). This plant has five 935-ton Variable Speed Drive (VSD) chillers and five 100-HP Variable Frequency Drive (VFD) primary CHW pumps. CC was applied to evaluate the already very efficient CUP, to further optimize its operation, and to reduce operational costs. Necessary tests were conducted to verify key equipment/system performance and proposed energy saving measures. Various CC measures such as loop differential pressure reset schedule, decoupling condenser water pumps from chiller operations, new chiller staging control, new cooling tower fan staging and temperature reset schedule control were proposed. The potential savings are \$60,000/yr with a retrofit cost of \$27,000. This paper presents methods, analyses, and results of this CC study. This paper also deals with portable air-conditioning units operation for temporary add-on cooling load in computer server rooms.

### DESCRIPTION OF THE SITE

The case study facility consists of seven buildings with about 1,000,000 sq.ft. building space. These building spaces are mainly used as offices and computer server rooms. The HVAC system consists of 56 air handler units (AHU), one fan coil unit (FCU) and 46 computer room air conditioning (CRAC) units using CHW to provide space cooling and electricity to provide space heating. These CRAC units are used as portable air-conditioning units for temporary add-on cooling load in computer server rooms. The CUP is located in the basement of one building and it consists of five 935-ton York centrifugal chillers. These chillers were constant speed chillers installed in 1991. Two of them have been retrofitted with

VSDs since 2000. The other three were retrofitted with VSDs in May 2005. The CHW distribution system (Figure 1) has five 100-HP primary CHW pumps and there is no building pump. Each CHW pump is dedicated to a chiller. It will be turned on whenever the corresponding chiller is energized. These pumps originally were constant speed pumps and were retrofitted with VFDs in 2005. The CUP condenser water (CW) system (Figure 2) consists of five cooling towers and five 100-HP constant speed CW pumps. Each cooling tower has a 50-HP two-speed motor to drive its fan. The energy management system (EMS) of the CUP and AHUs is "Metasys" Building Automation System of Johnson Control.

---

<sup>1</sup> Continuous Commissioning and CC are registered trademarks of the Texas Engineering Experiment Station (TEES), the Texas A&M University System, College Station, Texas.

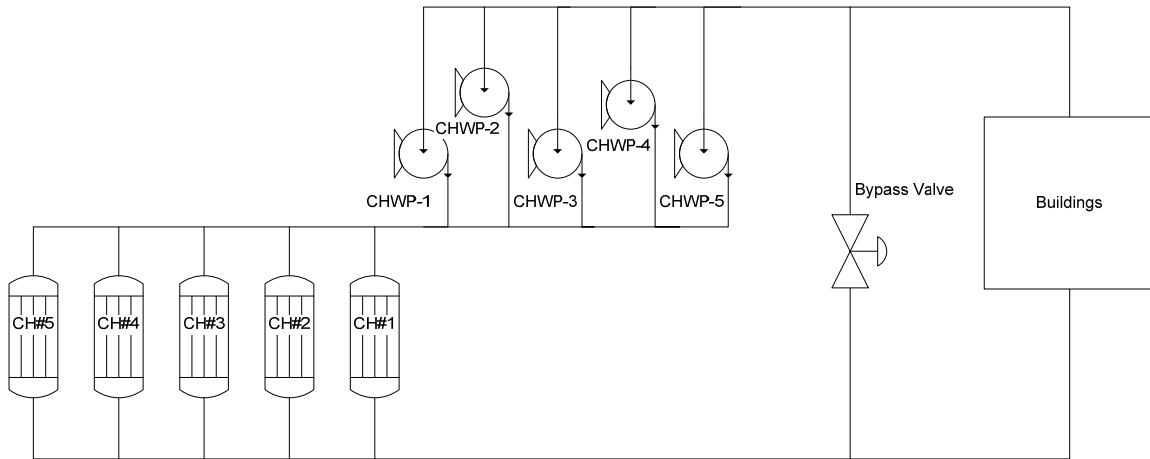

**Figure 1. CUP Chilled Water Piping Diagram**

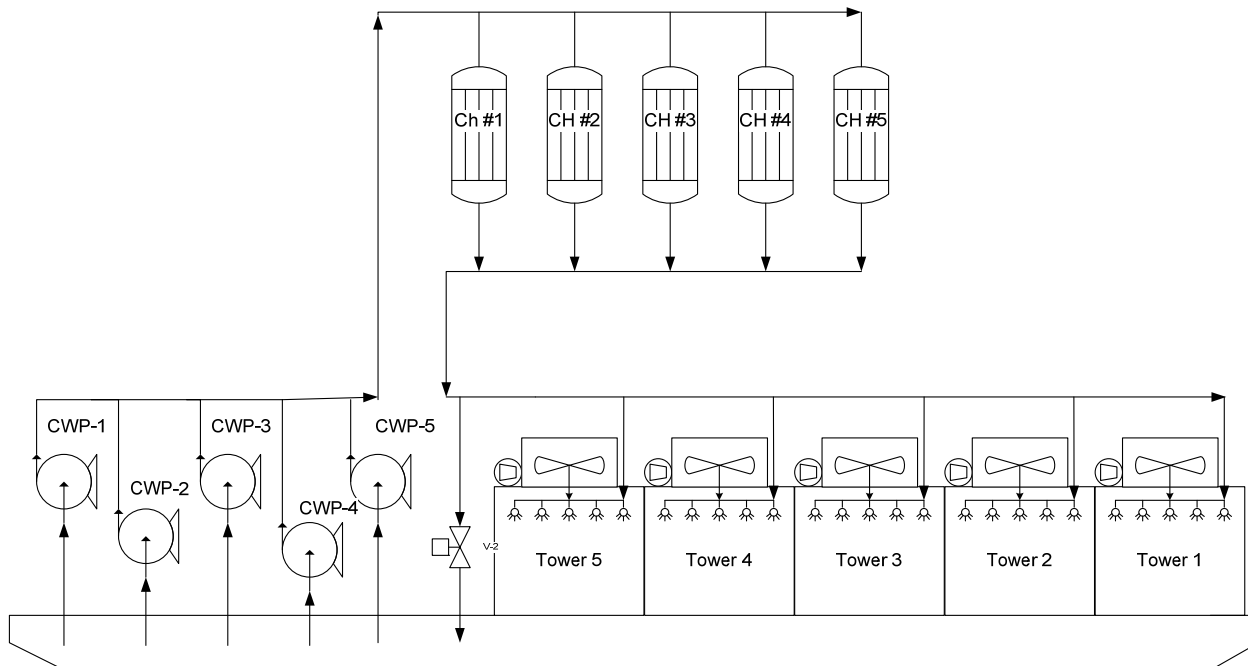
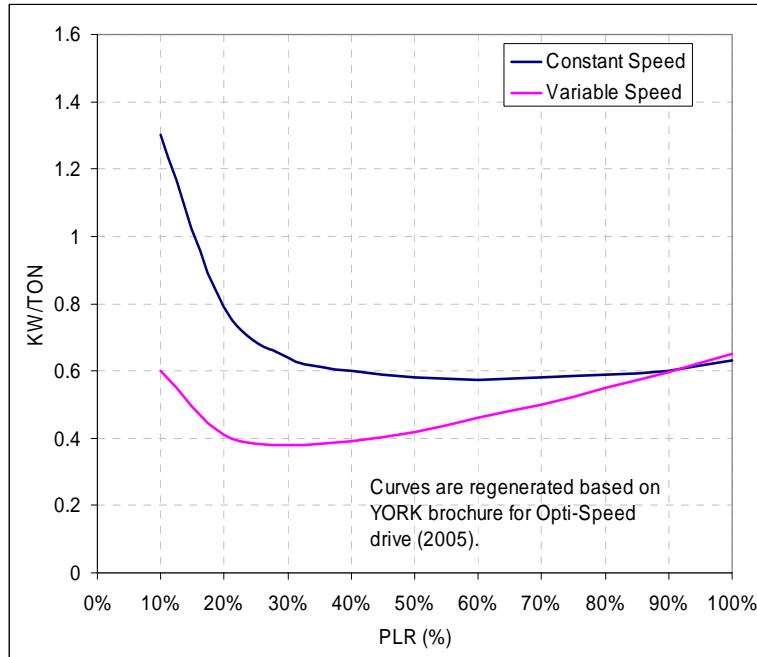

**Figure 2. CUP Condenser Water Piping Diagram**

### FIELD ASSESSMENT OBSERVATION AND CC MEASURES

In November 2005, an on-site CC assessment was conducted for the CUP to evaluate the existing system operation and to identify CC measures to further optimize the system operation and to reduce operational costs. A team of CC engineers conducted field investigation and tests to verify key equipment/system performances. The existing operations of the CUP have been overall trouble-free and very efficient. However, the detailed CC

assessment still identified measures to further improve its operation and energy efficiency. For the CHW side, the focuses were chiller staging strategy, chiller start/stop control, CHW differential pressure (DP) reset schedule, CHW flow control and Chiller CHW temperature reset control. For the CW water side, the focuses were CW temperature reset control, cooling tower fan staging control, and CW flow control. This paper presents some of the CC techniques utilized in this project.



**Figure 3. Performance Comparison between Constant Speed and Variable Speed Chillers**

### CHILLER STAGING CONTROL

The original chiller staging control was still in use, which was designed for the constant speed chillers. The control will activate a chiller, when the total chilled water tonnage indicates that online chillers are fully loaded.

According to YORK-provided literature about the OptiSpeed™ Variable-Speed Drive (see Figure 3), the performance characteristics of the chillers on site before and after retrofit are very different. The VSD chiller is much more efficient at partial load condition than a constant speed chiller. As long as the chiller load is above 30% of its design capacity, reducing cooling load on a VSD chiller can always significantly improve its efficiency when compared to a constant speed chiller.

In order to take advantage of high energy performance of the VSD chiller under lower load conditions, a new staging strategy was proposed to maximize chiller efficiency. The system cooling load is usually less than 3,300 tons, and there is 4,675-ton installed cooling capacity. Because there is redundant cooling capacity, the proposed control will activate a chiller when the campus cooling load reaches 65% of the total chiller cooling capacity online, until all

chillers are activated. When the campus cooling load is 200 tons (adjustable) lower than the stageup criteria of the previous stage, the control program will deactivate a chiller. This keeps the cooling load to be at least 32% of design value for each chiller. This new chiller staging control makes sure that the individual chiller are always operated in the high efficiency range comparing to the existing chiller staging control and therefore increase the overall CHW production efficiency.

In order to operate a plant efficiently, it is very important to update and to optimize the existing control sequence after system hardware retrofits/upgrades. In this case, the chillers' performance characteristics changed significantly after they were retrofitted with VSDs. Therefore, in order to operate these chillers more efficiently, it is necessary to upgrade the existing chiller control sequence as well. The recommended chiller staging control should further improve the already very efficient chiller performance by approximately 9.8% from 0.479 kw/ton to 0.432 kw/ton on annual average basis. The estimated annual energy savings are 647,194 kWh. Energy savings are about \$42,068 per year, assuming \$0.065/kWh.

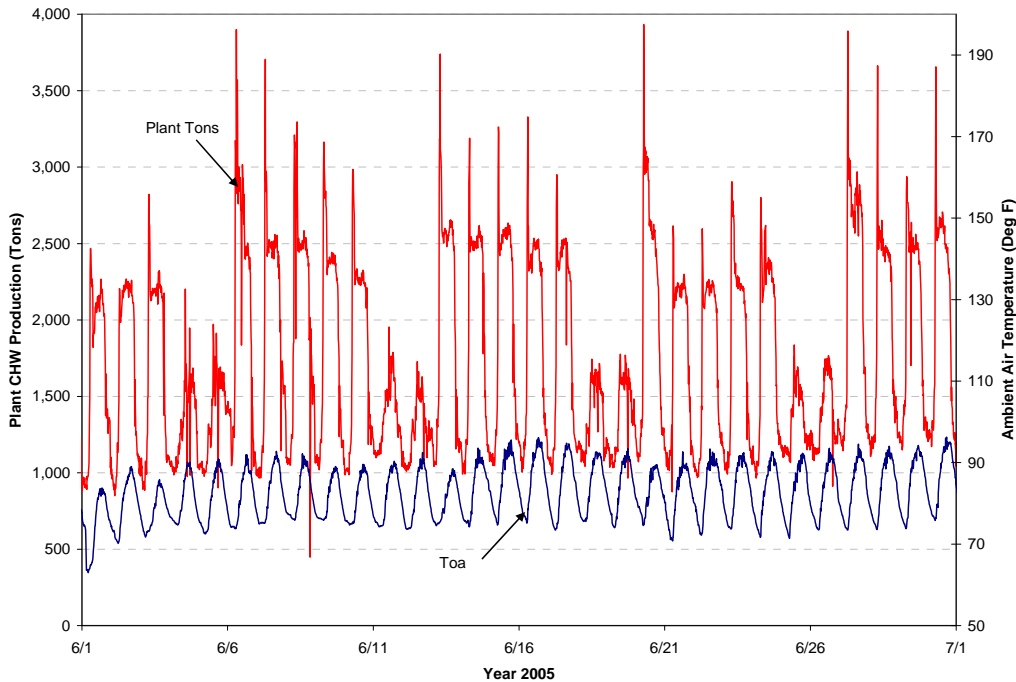

**Figure 4. Time Series of Cooling Load Spiking**

### COOLING LOAD SPIKING

According to the plant operator, the CHW load spikes every workday morning, especially Monday. The trended historical data (Figure 4) confirmed his comment. According to field interviews, 95% of the AHUs are shutdown during the night and weekend. They are started again before the working hours in the next morning in a very short period of time. Because the cooling load increases so fast during the AHUs start-up period, more chillers are forced to turn on unnecessarily. This will cause electrical load to spike, which results in higher electrical demand charge. The recommended CC measures below were intended to improve the chiller start/stop sequence control to reduce the electrical spike and to save electrical demand charge, especially in the summer.

Recommended CC measures:

- Spread AHUs' startup sequence
- Stage up chiller earlier
- Limit the maximum number of running chillers to three during AHUs startup period. According to the trended cooling load profile, three chillers should be enough.
- Increase the time span between the chillers stage up from 15 minutes to at least 30 minutes.

It is common to turn off AHUs during unoccupied hours in a facility to save energy. However, this measure could cause cooling load spikes in the plant during its start-up period, which might force extra chillers to be on unnecessarily and in turn results in electrical spikes and higher electrical demand charges. Therefore, besides the appropriate AHUs' start-up sequence, a proper control of chillers and other equipment from the plant side needs to be taken into consideration as well to maximize the energy savings.

### CHW DP RESET SCHEDULE

The existing CHW DP control was implemented after the installation of VFDs on the primary CHW pumps in 2005. These pumps are designed to supply 1,400 GPM at 175 ft head with a 100-HP motor. When a chiller is activated, a CHW pump dedicated to it will be turned on as well. The DP sensor is located across the CHW riser in the building at the loop end. According to plant operator, the existing DP set point was set to 25 PSID to avoid hot calls from computer server rooms. A building usually only needs to maintain a pressure drop of 3 – 5 PSID at loop end. This set point seems too high to the CC engineers.

Through field investigation and interview, the CC engineers found that there are mainly two types of CRAC units on site, i.e. DATAAC units and LIEBERT units. These CRAC units were used as portable air-conditioning units for temporary add-on cooling load in computer server rooms. They were tied directly in the loop without any pumps. According to their design information, the DATAAC units require 1.8 PSID to 2.7 pressure drop. The LIEBERT units require pressure drop of 17 PSID to 26 PSID. LIEBERT units were selected as current standard CRAC units for computer server rooms cooling purposes and there will be more LIEBERT units in this facility.

In order to avoid hot calls from computer server rooms, the existing CHW DP set point was changed to 25 PSID at the loop end, which is much more than the building AHUs needed. Most of the AHU CHW valves in the buildings were only 40% open during the field visit. Yet some of the CRAC units were still under performing because of less than design required DP. Field readings indicated that some of the fully loaded 40-ton LIEBERT CRAC units only got 13 PSID at its entrance.

In order to make the LIEBERT units perform as design specified, the system loop DP needs to be at least 35 PSID to make sure the 40-ton LIEBERT units get design required DP. But because the AHUs and the DATAAC units don't need such high DP, their control valves will remain mostly closed. From pumping power point of view, this operation is not energy efficient. Also, in the long run, these valves might turn bad and leak and result in higher maintenance cost and lower energy efficiency in building AHUs.

The dilemma here is that the plant operators cannot reduce the plant DP set point too much either, because if they do, the LIEBERT units won't be able to provide design specified cooling capacity and might not be able to maintain computer server room temperature and cause server failure.

The lesson is that the selected CRAC units need to have either similar DP requirement with the existing system or dedicated pumps, so that the impact on system loop DP could be minimized.

For this case, the recommended CC measures are:  
Decrease the current plant DP set point from 25 PSID to 5 PSID and install pumps on all LIEBERT CRAC units. There are seven 29-ton and seven 40-ton

LIEBERT units. Estimated pumping energy savings are 103,185 kWh. The energy cost savings are about \$6,707 per year. The total cost of purchase and installation of the CHW pumps is \$27,125. The advantages of this measure include maximum pumping energy saving, easier AHU coil control valve maintenance, and design specified DP for all LIEBERT CRAC units.

### COOLING TOWER WATER TEMPERATURE RESET AND FAN STAGING CONTROL

The CW system consists of five two-speed cooling towers and five CW pumps. The cooling tower design information is listed in Table 1. According to the original chiller ARI test results, every degree drop in CW temperature results in 1.0% increase in the chiller efficiency on average. The chillers are allowed to operate with CW entering temperature as low as 60 °F.

**Table 1 Cooling Tower Design Information**

Capacity	1,110 TONS per Cell
CW Return Temp.	95 °F
CW Supply Temp.	85 °F
Design Wet-bulb Temp.	78 °F
Fan Motor	Two-speed
Fan Motor HP	12.5/50 HP

To take advantage of this feature, the existing cooling tower fan staging control sequence has a variable CW temperature setpoint based on ambient wet-bulb temperature and system load. If the CW temperature rises above set point, the controller will energize a fan to low speed in steps of one °F in the staging order. If the temperature continues to rise with all fans at low speed, the fans will switch to high speed, again in steps of one °F. Each fan will go off at three °F below its turn on temperature. The CW temperature set point for the first stage of fan control is determined by the wet-bulb temperature plus one °F bias.

Based on the observation of trended historical data (see Figure 5), when ambient air wet-bulb temperature is above 60 °F, the minimum approach is about four °F and the maximum approach is about 14 °F, and the average approach is about seven °F. At any given ambient wet-bulb temperature, the spread may be 10 °F or so. For example, at 60 °F ambient wet-bulb temperature, the CW temperatures are from 64 °F to 74 °F. The overall control is not very tight. Five cooling towers have a total of 10 stages, which

is consistent with the existing control sequence. At any given wet-bulb temperature, with one °F stage up and three °F stage down criteria, when the load varies, the CW temperature will spread about 10 °F.

The problem of this fan staging control is that there is no optimal parameters to operate the cooling tower fans efficiently while avoiding frequent fan cycling. Reducing the fan stage up/down increments could narrow the CW temperature spread, but the fans would cycle on/off more often. Increasing the first stage CW temperature bias could improve the fan operation at lower stages, but the setpoints for higher stages will be too high that the chillers wouldn't be able to reach their optimal efficiencies.

A new CW temperature reset control was recommended (see Figure 6). The ambient wet-bulb temperature plus a constant approach (e.g. seven °F)

with a minimum of 60 °F, determines the CW temperature set point. As far as the fan staging control is concerned, the recommendation is that if the CW temperature rises above the set point by one °F, the fan control will stage up. If the CW temperature drops below the set point by one °F, the fan control will stage down. This cooling tower fan control was much more simpler and easy to implement. Both the fan stage up/down increments were adjustable, which could help avoid frequent fan cycling and could provide more precise control on CW temperature with tighter CW temperature spread. The CW temperature reset schedule can be adjusted to optimize the energy efficiency of the chillers and cooling tower fans. Because this control sequence handles the fan cycling control and CW temperature reset schedule were handled separately, there is no need to worry about the interaction between them.

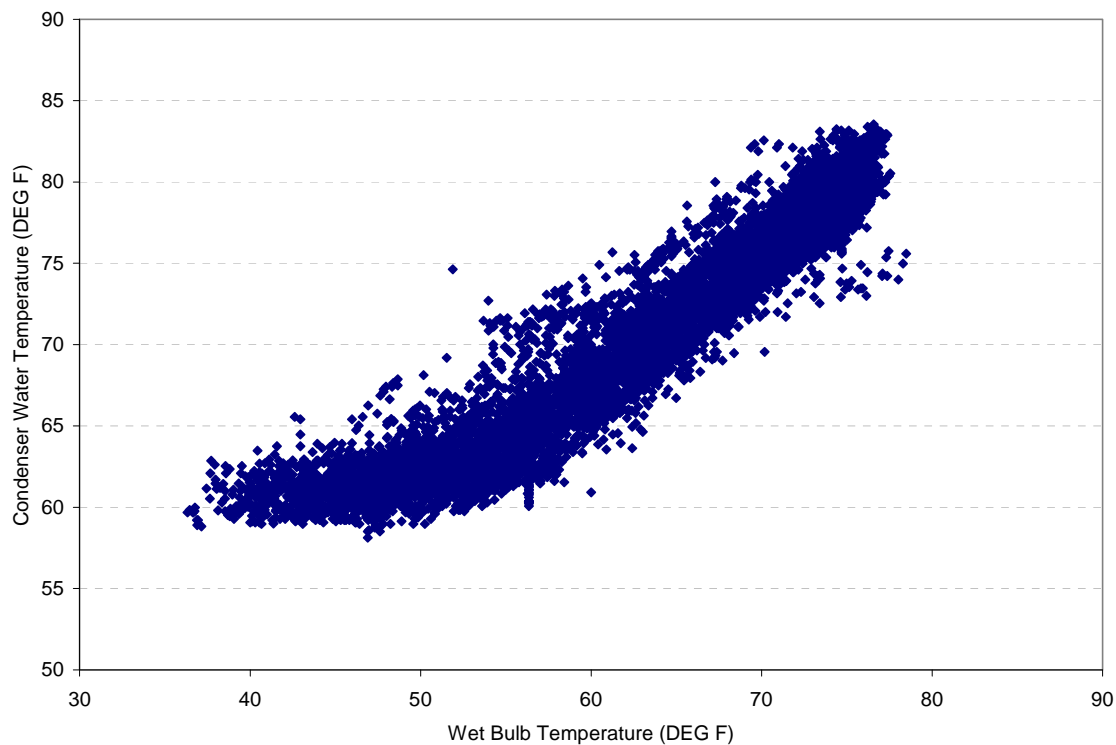

**Figure 5. Relationship between CW Temperature and Wet-bulb Temperature**

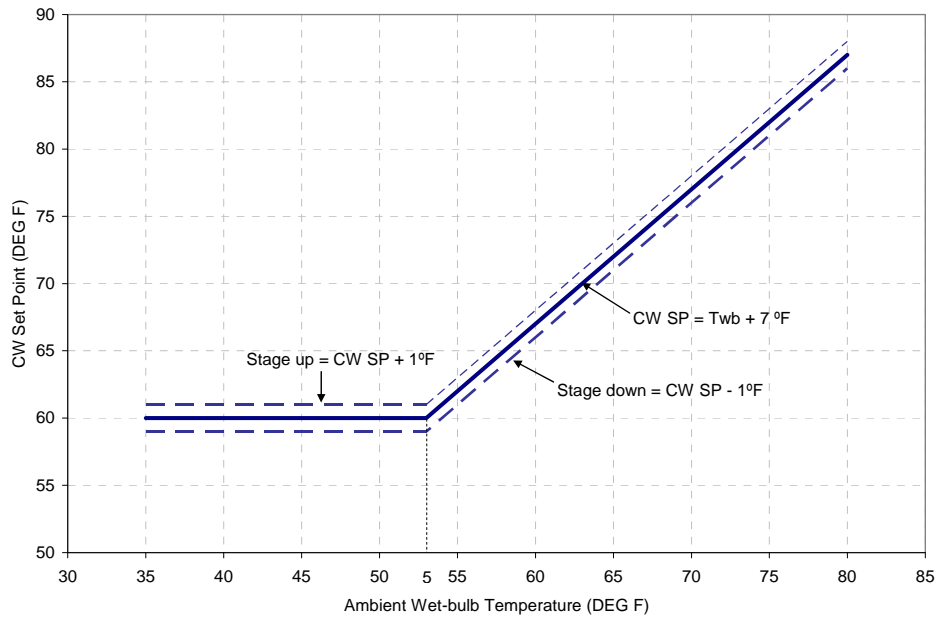

**Figure 6. Proposed Cooling Tower Fan Staging Control**

**CW PUMPS DECOUPLING**

There are five constant speed CW pumps on site. The existing CW pump control dedicate each of the pumps to a chiller. When a chiller is activated, a CW pump dedicated to it will be activated as well. The CW flow for each chiller is maintained at design flow of 2,800 GPM by modulating the CW valve on each chiller. These valves were only about 27% open on average when there were three chillers in operation during field investigation (see Table 2). According to the design performance curves of the CW pumps, each of the pumps should be able to provide up to 4,500 GPM, which means that it is possible to run three chillers with only two CW pumps and to run four chillers with three CW pumps. After shutting off one CW pump, the average CW valves’ position increased to 49% (see Table 2). This confirmed that two CW pumps indeed have the capacity to provide designed CW flow to three chillers. Therefore, the recommendation was to decouple the CW pump operation from the chillers. The existing and proposed CW pump control is listed in Table 3.

Usually, the staging control of the CW pumps are coupled with the chillers. However, when the CW pumps have adequate capacities, they could be operated with separate staging control. Shutting off unnecessary CW pumps could achieve significant

savings. For this case, the estimated annual pumping energy savings are 169,548 kWh or \$11,021 per year.

**Table 2 Condenser Water Pump Tests Results**

	Test 1	Test 2
Date	11/03/2005	11/03/2005
Time	13:57 PM	14:13 PM
# of Chillers ON	3	3
# of CW Pumps ON	3	2
CWV Pos (% OPEN)	CH #1	36%
	CH #2	23%
	CH #5	21%
CW Flow (GPM)	CH #1	2,707
	CH #2	2,770
	CH #5	2,755

**Table 3 Proposed and Current CW Pump Control**

	Current Control	Proposed Control
# of Chillers ON	# of CW Pump ON	# of CW Pump ON
1	1	1
2	2	2
3	3	2
4	4	3
5	5	4

**CONCLUSIONS**

This paper discussed several CC measures in detail, such as measures to optimize VSD chiller operations, techniques to minimize electrical spikes due to AHUs' start-up, how to deal with the portable CRAC units for temporary add-on cooling load in computer server rooms, development of optimized staging control for two-speed cooling towers, and method to improve CW pump staging control. For the case study facility, the total energy and cost savings would

be approximately 920,000 kWh and \$60,000 per year. Total investment in additional pumping is \$27,000. Overall payback time is less than 6 months.

This case study demonstrated that even for a well maintained and already efficient chiller plant, there is still good potential to reduce energy use and to improve comfort. CC technology is cost-effective in improving the comfort level and reducing energy consumptions.