

**AN EXPERIMENTAL SETUP TO EVALUATE THE  
DAYLIGHTING PERFORMANCE OF AN ADVANCED OPTICAL  
LIGHT PIPE FOR DEEP-PLAN OFFICE BUILDINGS**

A Thesis

by

BETINA GISELA MARTINS MOGO DE NADAL

Submitted to the Office of Graduate Studies of  
Texas A&M University  
in partial fulfillment of the requirements for the degree of

MASTER OF SCIENCE

August 2005

Major Subject: Architecture

**AN EXPERIMENTAL SETUP TO EVALUATE THE  
DAYLIGHTING PERFORMANCE OF AN ADVANCED OPTICAL  
LIGHT PIPE FOR DEEP-PLAN OFFICE BUILDINGS**

A Thesis

by

BETINA GISELA MARTINS MOGO DE NADAL

Submitted to the Office of Graduate Studies of  
Texas A&M University  
in partial fulfillment of the requirements for the degree of

MASTER OF SCIENCE

Approved by:

Chair of Committee,	Liliana O. Beltrán
Committee Members,	Ergun Akleman
	John Leggett
Head of Department,	Phillip Tabb

August 2005

Major Subject: Architecture

## ABSTRACT

An Experimental Setup to Evaluate the Daylighting Performance of an Advanced Optical Light Pipe for Deep-Plan Office Buildings. (August 2005)  
Betina Gisela Martins Mogo de Nadal, Dip. in Arch., Universidad Nacional de Rosario  
Chair of Advisory Committee: Dr. Liliana O. Beltrán

This research focuses on an advanced optical light pipe daylighting system as a means to deliver natural light at the back of deep-plan office buildings (15ft to 30ft), using optimized geometry and high reflective materials. The light pipe configurations follow a previous study at the Lawrence Berkeley National Laboratory (Beltrán et al., 1997). The current system is designed for College Station, TX (lat: 30° 36'N), with predominantly mostly sunny sky conditions.

This work consists of the monitoring of two scale models simulating a portion of a multi-story office building with open-plan configuration, with interior dimensions 30ft x 20ft x 10ft, built at 1:4 of its real scale, one of the models being the reference case and the other the test case where the light pipe system is placed.

The main objectives of this thesis are (a) to examine this daylighting system comparative to the reference case, taking measurements for longer periods than the study at LBNL, as well as to collect detailed data of its performance under different weather conditions and with different materials; (b) to evaluate the visual comfort and possible glare problems of the light pipe system through photographic evaluation and the conduction of a survey that provides people's opinions and suggestions about the daylighting system.

The light pipe system demonstrated a higher performance than the reference case in terms of appropriate levels of light and people's preferences. The illuminance at the workplane level showed to be adequate with any of the two different diffusing materials used to spread the light into the room. The light pipe without a diffuser was the other

condition observed to further understand the bounces of the sunbeam inside the reflective chamber and its consequences on the lighting output.

Recommended standards for office spaces with VDT screens together with the analysis of the daylight system, led to preliminary suggestions on how to integrate the light pipe system in an open-plan office configuration. Further study is indicated to reach the complete potential of this advanced optical light pipe that ties illuminance quality with energy savings through the integration of daylight and electric light systems.

## **DEDICATION**

*To my daughter Sofía,  
who gave me the strength to complete this thesis*

## ACKNOWLEDGMENTS

The pursuit of this thesis has taught me many valuable things: that everything is possible if you are determined and believe in what you are doing, and, that some periods on the timeline of a person's life can be so crowded and complicated that you think you will never complete them, but eventually you will.

I would like to express my gratitude to all the people who helped me during this time. Without their generosity, I would never have been able to finish this work. I would like to extend my deepest thanks to Dr. Liliana Beltran, chair of my advisory committee, for her support, her precious guidance, and her encouragement during the entire process of this study. My sincere gratitude goes out to Dr. Ergun Akleman and Dr. John Leggett, members of my advisory committee, for their time and valuable advice on this research.

I would also like to thank Chuck Tedrick and all the student workers at the Woodshop who helped me to build the models. I greatly appreciate the collaboration of Dr. Jeff Haberl, who generously provided me with the shadow band necessary for this study. I would like to extend special thanks to Kelly Millican and Jim Sweeny for their help and advice on setting up the equipment for the experiment. I would also like to acknowledge the collaboration of Dr. Richard Furuta and two of his students, Ray Evans and Joshua Edwards, on their study of the datalogger's software and development of a remote access and retrieval of data.

Finally, I am deeply indebted to my family from close and afar for their encouragement and help. My special thanks to my "Longhorn" husband who many times played the roll of single Daddy, taking care of Sofia. To my lovely daughter Sofia, who patiently waited for her Mommy to finish this thesis so there would be more "Mommy time" for her. The most particular gratitude to my two moms: Norma, my mom, and Marta, my mom-in-law, who left their homes in Argentina for long periods to take care of Sofia, and to their husbands, my dads, to let them come. Furthermore, particular thanks to Alicia, my substitute mom in the US, for taking care of Sofia so many times. Thanks to all of them for being close to me when I needed it the most.

## TABLE OF CONTENTS

	Page
ABSTRACT .....	iii
DEDICATION .....	v
ACKNOWLEDGMENTS.....	vi
TABLE OF CONTENTS .....	vii
LIST OF TABLES .....	x
LIST OF FIGURES.....	xi
 CHAPTER	
I INTRODUCTION.....	1
1.1. Background.....	1
1.2. Statement of the Problem and Research Purpose .....	2
1.3. Objectives .....	3
1.4. Research Design .....	3
1.5. Significance of the Proposed Study .....	3
1.6. Scope of Research.....	4
1.7. Organization of the Thesis.....	5
II LITERATURE REVIEW.....	6
2.1. Daylight in Offices.....	6
2.1.1. Use of daylight in office buildings .....	6
2.1.2. Effects of daylight in building occupants.....	10
2.2. Advanced Daylight Systems .....	12
2.2.1. Introduction and classification .....	12
2.2.2. Light guides.....	13
2.2.2.1. Remote lighting.....	13
2.2.2.2. Vertical light pipes.....	14
2.2.2.3. Horizontal light pipes.....	15
2.3. Daylight Evaluation .....	17
2.3.1. Scaled models.....	17

CHAPTER	Page
2.3.2. Photometric evaluation.....	18
2.3.3. Lighting quality and visual comfort evaluation .....	19
2.3.4. Visual observation.....	20
III METHODOLOGY .....	22
3.1. Construction of Physical Scale Models .....	22
3.1.1. Scale models: design and construction.....	22
3.1.2. Light pipe prototypes: materials, design and construction.....	27
3.2. Evaluation Methods .....	33
3.2.1. Data collection with a datalogger and photometric sensors .....	33
3.2.2. Visual assessment.....	36
3.2.2.1. The use of luminance ratios and photographic documentation for visual comfort evaluation.....	36
3.2.2.2. Survey for human response evaluation.....	37
IV DATA ANALYSIS .....	38
4.1. Measurements under Clear Sky Conditions.....	38
4.2. Raytracing with Time-Lapse Images .....	54
4.3. Measurements under Overcast Sky Conditions .....	55
4.4. Analysis of Visual Comfort and Glare Analysis .....	58
4.4.1. Photographic documentation with HDR images and luminance ratios .....	58
4.4.2. Analysis of survey for human response evaluation.....	61
V CONCLUSIONS AND FUTURE WORK .....	69
5.1. Conclusions about the Use of Light Pipes as a Means to Illuminate Deep Plans .....	69
5.1.1. Conclusions about illuminance values .....	69
5.1.2. Conclusions about design and materials used .....	70
5.1.3. Conclusions about visual comfort and people acceptance .....	70
5.2. Future Work .....	71
REFERENCES .....	73
APPENDIX A .....	78



	Page
APPENDIX B .....	81
APPENDIX C .....	83
APPENDIX D .....	85
APPENDIX E.....	90
APPENDIX F.....	94
APPENDIX G .....	103
APPENDIX H.....	105
APPENDIX I.....	120
APPENDIX J.....	125
VITA .....	129

## LIST OF TABLES

TABLE		Page
1	Determination of illuminance categories .....	8
2	Floor, ceiling, walls, and furniture reflectances.....	23
3	Annual cloudiness for Austin, TX, with 54 years of data collected .....	32
4	Cloudiness for College Station, TX, for the year 2003 only .....	32
5	Cloud Cover categories according to sunlight probability data bins by Robbins, 1996 .....	33
6	Workplane illuminance (lux) of the three light pipe conditions at 24 ft, with lower window contribution .....	39
7	Average illuminance at the half-front (max.) and half-back of the space (min.) and the resulting illuminance contrast gradient (ICG) for two light pipe conditions compared to the reference case .....	42
8	Maximum and minimum workplane illuminance (lux) and illuminance contrast gradient (ICG) across the 15-30 ft area for the three light pipe conditions without lower window .....	53
9	Maximum and minimum workplane illuminance (lux) and illuminance contrast gradient (ICG) across the 15-30 ft area for the three light pipe conditions with lower window contribution.....	53
10	Information of people who attended the survey on 02/03/2005 and 02/04/2005 .....	62
11	Working environment and lighting preferences of people who attended the survey .....	62

## LIST OF FIGURES

FIGURE		Page
1	Reflectances recommended for room and furniture surfaces in offices .....	9
2	Maximum luminance ratios recommended for a VDT workstation .....	10
3	A conceptual framework setting out the three routes whereby lighting conditions can influence human performance.....	11
4	Remote lighting.....	14
5	Vertical light pipes.....	15
6	Reference model plan view.....	24
7	Reference model longitudinal section.....	24
8	(a) Reference model front view, (b) test model front view .....	25
9	Experiment layout on Langford building's roof .....	26
10	Setup to find North-South axis at solar noon.....	26
11	Light pipe design in plan view.....	28
12	Light pipe design in section .....	28
13	Detail of central reflectors. ....	29
14	Design of side reflectors for oblique sun-angles .....	29
15	Reference model 360° photograph with superimposed sunpath for College Station, lat: 30°36'N.....	31
16	Test model 360° photograph with superimposed sunpath for College Station, lat: 30°36'N.....	31
17	Arrangement of sensors inside and outside both models.....	34
18	Exterior photometric sensors .....	35
19	Workplane illuminance distribution on February 14th for light pipe with Mylar® diffuser in test model .....	40
20	Workplane illuminance distribution on March 12th for light pipe with Barrisol ® diffuser in test model .....	41

FIGURE	Page
21	Two consecutive HDR images on March 1st at 1pm ..... 43
22	Workplane illuminance (h: 28") longitudinally along the middle of the space, due to daylight contribution from window with closed blinds and from light pipe with Mylar, and the total combination of both contributions ..... 44
23	Workplane illuminance (h: 28") longitudinally along the middle of the space, due to light pipe with Mylar® and window with blinds in test model, and window with closed blinds in reference model ..... 45
24	Workplane illuminance (h: 28") longitudinally along the middle of the space, due to light pipe with Barrisol® and window with closed blinds in test model, and window with closed blinds in reference model ..... 47
25	Workplane illuminance (lux) due to raw light pipe without window contribution ..... 50
26	Workplane illuminance (lux) due to light pipe with Mylar® without window contribution ..... 51
27	Workplane illuminance (lux) due to light pipe with Barrisol® without window contribution ..... 52
28	Time-lapse images from 9:30am to 12pm, showing the raw light pipe output casting changing patterns on side and back walls ..... 55
29	Workplane illuminance (h: 28") from window with semi-opened blinds and light pipe with Mylar® under overcast conditions ..... 56
30	Workplane illuminance (h: 28") from window with closed blinds and light pipe with Mylar® under overcast conditions ..... 56
31	Workplane illuminance (h: 28") in reference model and in test model with light pipe with Mylar® with semi-opened blinds in both models under overcast conditions ..... 57
32	Daylight factor on the workplane (h: 28") at the center of the space in the test model due to light pipe with Mylar® and window with semi-opened blinds ..... 57
33	HDR image of light pipe with Mylar® on March 1st at 1pm with spot luminance measurements of four reference points ..... 58
34	Iso-contours generated with Desktop Radiance of (a) low luminance values, (b) high luminance values ..... 59

FIGURE	Page
35	Luminance ratios between (a) the point at the desk and the three other reference points, (b) the VDT screen, with a luminance value of 90 cd/m <sup>2</sup> , and the three other reference points..... 59
36	Arrangement of light pipes in an open-plan office to evaluate direct glare depending on contrast ratio between VDT screen and light pipe luminance values ..... 61
37	Reflected glare on VDT monitor ..... 61
38	Different sky conditions during the survey on February 3rd and 4 <sup>th</sup> ..... 63
39	Question #8: What is your impression, at first glance, of the overall lighting conditions?..... 63
40	Probability of turning on the electric light..... 64
41	Question #12: In which part of the space would you prefer to sit if you were working in model #1? And in model #2?..... 65
42	Question #14: Is there too much light in some areas and not enough in others? Where? ..... 65
43	Question #15: Do you think that there are enough glare problems in model #1 to bother you? And in model #2? If yes, please say where ..... 66
44	Transversal section of test model with observer evaluating glare ..... 67
45	Question #17: Do you use some kind of glasses? Please specify all that apply..... 67

# CHAPTER I

## INTRODUCTION

### 1.1. BACKGROUND

Over the last decade there has been an increased interest in saving energy. This, together with a growing concern for the environment, has promoted the growth of daylight technology in the field of sustainable architecture. Furthermore, several studies have proved that natural light increases human performance and comfort in indoor spaces (Heschong-Mahone Group, 2003). The use of daylight appears then as a good strategy to offset artificial illumination and to make a space more amenable, but it also has its design challenges. Because of the variability of sunlight, daylighting science attempts to provide daylight and at the same time to control direct sunlight, glare problems, and heat-gain (Stein and Reynolds, 2000). Such requisites will vary depending on the location of the building, its function and occupancy periods, and its configuration and dimensions.

In commercial buildings, for economic reasons, one of the most common design configurations is the multi-story, deep-plan building, with maximum ratio of usable floor area to exterior envelope. The natural light in these types of buildings is mainly day-lit through windows on the perimeter, but the daylight zone will rarely reach the first 15 ft from the window plane. The result is an uneven illumination, with high concentration of illuminance levels near the glazing and very low levels at the back of the spaces. Therefore, the core of these buildings is dark and depends exclusively on electrical lighting for obtaining adequate illumination, leading to the subsequent increase in energy consumption.

Moreover, in an office building the use of electricity due to lighting could be as

---

This thesis follows the style and format of the Solar Energy Journal.

much as 50% of the total energy usage. In the hot season, the need of mechanical cooling to control the excess heat generated by artificial lighting results in the use of even more energy (McNicholl and Lewis, Eds., 1994). The use of daylighting can lead to substantial energy savings of around 20-40% for lighting use (Crisp et al., 1988).

Sophisticated daylighting systems and techniques have been studied to control daylight intensity and to efficiently distribute it in the interior space. Particularly, for side-lit multi-story buildings with deep plans, one approach to capture daylight and efficiently channel it towards the core (from 15ft to 30ft) is the light pipe. For the visual satisfaction of its occupants, it aims to provide light to the deepest part of the room to combine with sidelighting and seeks a more uniform illumination across the space, without glare problems. Due to the variations of daylight according to location, season, and cloudiness, it is necessary to integrate daylight with electric light in order to accommodate lighting requirements. Furthermore, in order to obtain energy savings from daylighting, it is mandatory to use lighting zones and photoelectric controls (IEA SHC Task 21, 2000).

## **1.2. STATEMENT OF THE PROBLEM AND RESEARCH PURPOSE**

Literature about light pipes is limited mainly because there are no prototypes that have been developed or manufactured. Vertical configurations are abundant, but their use is limited to single-story buildings and the need for expensive technology to concentrate the sun beam. Horizontal configurations have been studied for east-west façades or overcast conditions, and in some cases, the technology used is complicated because it involves moveable parts.

The purpose of this research is the further study of a horizontal light pipe for sunny and partly sunny conditions that was developed at LBNL (Beltrán et al., 1997). It takes the same design as the original, but the scale has been incremented for a better understanding of the light pipe performance. In addition, visual comfort is evaluated and people's opinions are gathered in a survey.

This light pipe passively redirects the beam sunlight from the façade plane towards the back of the room, increasing daylight levels at the rear of deep-plan office buildings. For such a purpose, this daylight system utilizes optimized geometry and high reflective films (Beltrán et al., 1997).

### **1.3. OBJECTIVES**

The objectives of this research are the following:

- a. To monitor this daylighting system for longer periods than the previous study as well as to collect detailed data of its performance under different weather conditions and with different materials.
- b. To evaluate the visual comfort of the light pipe system.
- c. To obtain people's feedback and opinions about the light pipe system as a starting point in its building integration and future commercialization.

### **1.4. RESEARCH DESIGN**

For the assessment of the present research, an experimental setup placed at College Station, TX (lat: 30°36'N, long: 96°22'W) was built. It consisted of two scale models reproducing conventional office rooms: the reference case and the test case. The test case was for testing the light pipe. The study was comparative and involved taking data simultaneously in both models. It comprised the collection of interior and exterior illuminance levels, interior luminance ratios, a series of interior and exterior photographs, and people's opinions towards the system in terms of visual comfort and acceptance.

### **1.5. SIGNIFICANCE OF THE PROPOSED STUDY**

The current research is unique as:

- The experiment introduces a benchmark for an office space. This reference provides data for a fair comparison with the system under study.



- The size of the models (3 in = 1 ft) allows for more detail in the design of the light pipes as well as creates an immersive environment to obtain people's feedback about the system.
- The evaluation of the visual comfort is assessed with a singular method that combines high dynamic range images with luminance maps.

## **1.6. SCOPE OF RESEARCH**

Advanced daylighting systems have proved to be an effective means to redirect sunlight further into interior spaces. This study covers the natural illumination in core areas (from 15 ft to 30 ft), a subject that has been investigated scarcely at all. Commercial buildings are a fertile field for future implementation of these systems, as most of these buildings have deep-plan configurations. Also, schools are another good candidate for the implementation of horizontal light pipes. This study assumed a typical office as an open space of 30 ft x 20 ft x 10 ft, with a window covered with white Venetian blinds and an array of six desks paired at the center of the room. Such a space was considered the reference case or benchmark.

The research was limited with respect to the following aspects. The horizontal light pipes were designed for predominantly sunny or mostly sunny sky conditions of the city of College Station, Texas, latitude 30° 36'N, and they were oriented towards the south. The study demonstrates the efficiency of the system for this latitude. However, to achieve the same efficiency for other latitudes, the design will need to be adjusted accordingly, depending on the latitude of the building's location. Different materials were tested in the light pipe emitter section in order to find the transmittance that gave an adequate task illuminance without glare problems. The annual energy performance was not evaluated because of the limited time for the research. Although the final purpose of advanced daylighting systems is its integration with electric lighting systems, due to the difficulties for scaling electric light, this aspect is recommended to be investigated in future full-scale models.

## **1.7. ORGANIZATION OF THE THESIS**

The body of the thesis consists of five chapters:

Chapter I gives a first glance at the reason to use daylighting as a strategy for offsetting energy consumption in office buildings. It introduces the use of the light pipe technology as a means to illuminate dark core areas in deep-plan buildings. Then, it establishes the purpose of the present research and mentions its objectives and significance.

Chapter II refers to the use and advantages of daylighting in office buildings. It explores the previous studies about light pipes with their findings and drawbacks and the tools used for daylight evaluation.

Chapter III presents the methodology used for pursuing the research. It covers the design and construction of the scale models and the light pipe system, and the quantitative and qualitative methods utilized for its evaluation.

Chapter IV includes the analysis of the numerical data comparing the reference case with the light pipe case. It later analyzes the contribution of three different light pipes conditions by themselves. This chapter also includes the photographic documentation and the evaluation of the survey conducted to obtain people's opinion about the daylighting system.

Chapter V contains the conclusions about the light pipe system and gives recommendations for future studies on this matter.

## **CHAPTER II**

### **LITERATURE REVIEW**

This chapter contains a discussion of selected literature that forms the background of this research. The review of the literature starts with the use of daylighting in office buildings and its influence on office workers. Then, an introduction and detailed review of advanced daylighting systems refer to previous studies about light transport systems. Finally, methods of daylighting assessment, which constitute the basis of the methodology used in this study, are examined.

#### **2.1. DAYLIGHT IN OFFICES**

##### **2.1.1. Use of Daylight in Office Buildings**

Since the arrival of electricity, the design of modern buildings has relied on artificial lighting and air conditioning. Thus, daylight availability has depended much more on facade composition and corporate image than on common sense.

However, an actual concern about energy savings and visual comfort has brought particular attention to the studied design of daylight introduction into building interiors. The rediscovering of the sun as a design tool helps to produce more interesting buildings which are aware of their environment (Grimme et al, 2002).

The advantages of using daylighting in office buildings are several: increased productivity and decreased absenteeism; reduction in electric lighting and cooling loads that together represent 30% to 40% of the total energy use in a typical commercial building. Besides, energy-efficient buildings are good real estate investments –better lease rates, faster investment return, and higher cash flows– and have a lower impact on the environment (O'Connor et al., 1997).

The most common office type is the side-lit office. A good fenestration design should aim to provide enough illumination for the development of tasks, a view to the outside, and visual comfort for the occupants. However, it is not easy to meet all these

requirements. Some daylighting design guidelines try to make this design process easier. According to the IESNA Lighting Handbook (IESNA, 2000) the evolution of a particular design involves the following steps: 1) revise the balance between luminance and illuminance levels for better visual comfort and light quality; 2) design daylighting openings and shading devices according to the necessity of direct or diffuse daylight in the space; 3) control any glare problems; 4) review daylight and electric light integration. The Chartered Institution of Building Services Engineers in its Daylighting and Window Design (CIBSE, 1999) gives a more detailed checklist. It adds to the IESNA list and mentions other considerations that include a correct relationship between window size and room depth, between window size and adequate task illuminance, and the correlation between window size and thermal repercussion. It also considers daylight redirecting systems to improve light uniformity and openings for ventilation as well as window frame and glazing.

Illuminance of an office space consists of ambient and task lighting. The purpose of ambient lighting is to give a uniform light level that allows casual work. In general, ambient light is approximately one-third of task lighting, which is about 500-600 lux (Benya et al., 2003). For offices with partitions, ambient lighting should be higher because the partitions reduce the average ambient illumination level by 30%-35% due to their reflectance and height (Benya et al., 2003). In particular, illuminance levels will depend on the characteristics of the visual task being illuminated, as seen in Table 1. Ambient lighting can be achieved by daylighting, but task lighting is generally dependent on electric lighting.

Table 1  
Determination of illuminance categories

*Orientation and simple visual tasks.* Visual performance is largely unimportant. These tasks are found in public spaces where reading and visual inspection are only occasionally performed. Higher levels are recommended for tasks where visual performance is occasionally important.

A	Public spaces	30 lx (3 fc)
B	Simple orientation for short visits	50 lx (5 fc)
C	Working spaces where simple visual tasks are performed	100 lx (10 fc)

*Common visual tasks.* Visual performance is important. These tasks are found in commercial, industrial and residential applications. Recommended illuminance levels differ because of the characteristics of the visual task being illuminated. Higher levels are recommended for visual tasks with critical elements of low contrast or small size.

D	Performance of visual tasks of high contrast and large size	300 lx (30 fc)
E	Performance of visual tasks of high contrast and small size, or visual tasks of low contrast and large size	500 lx (50 fc)
F	Performance of visual tasks of low contrast and small size	1000 lx (100 fc)

*Special visual tasks.* Visual performance is of critical importance. These tasks are very specialized, including those with very small or very low contrast critical elements. Recommended illuminance levels should be achieved with supplementary task lighting. Higher recommended levels are often achieved by moving the light source closer to the task.

G	Performance of visual tasks near threshold	3000 to 10,000 lx (300 to 1000 fc)
---	--	---------------------------------------

\* Expected accuracy in illuminance calculations are given in Chapter 9, Lighting Calculations. To account for both uncertainty in photometric measurements and uncertainty in space reflections, measured illuminances should be with  $\pm 10\%$  of the recommended value. It should be noted, however, that the final illuminance may deviate from these recommended values due to other lighting design criteria.

Source: IESNA Lighting Handbook, 2000.

Daylighting illuminance in a space is commonly expressed as a percentage of the ratio between interior illuminance at a point over the working plane, and exterior illuminance measured horizontally under overcast conditions, and is called Daylight Factor (DF). Average Daylight Factor considers the average of interior illuminances.

Adequate brightness variations are important in an office environment to provide good visibility without unwanted reflections. For that reason, knowledge of interior finishes as well as location of video display terminals (VDT) is important. Reflectances recommended by IESNA (IESNA, 2000) can be seen in Figure 1.

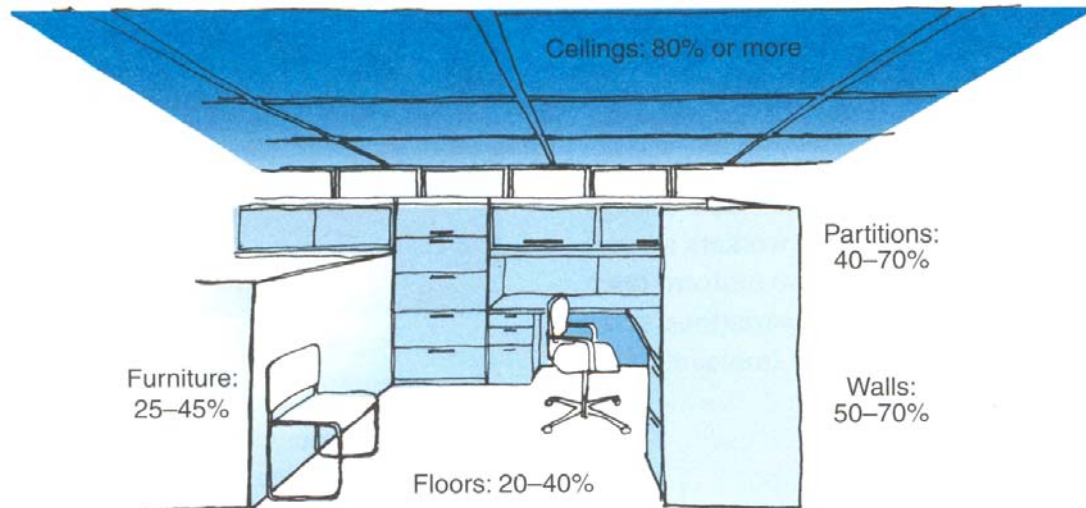


Fig. 1. Reflectances recommended for room and furniture surfaces in offices. *Source: IESNA Lighting Handbook, 2000.*

The luminance ratios establish the relationships among these reflectances within the field of view. To avoid contrasts and possible glare problems, luminance ratios need to be equal or below recommended values, as Figure 2 illustrates (IESNA, 2000).

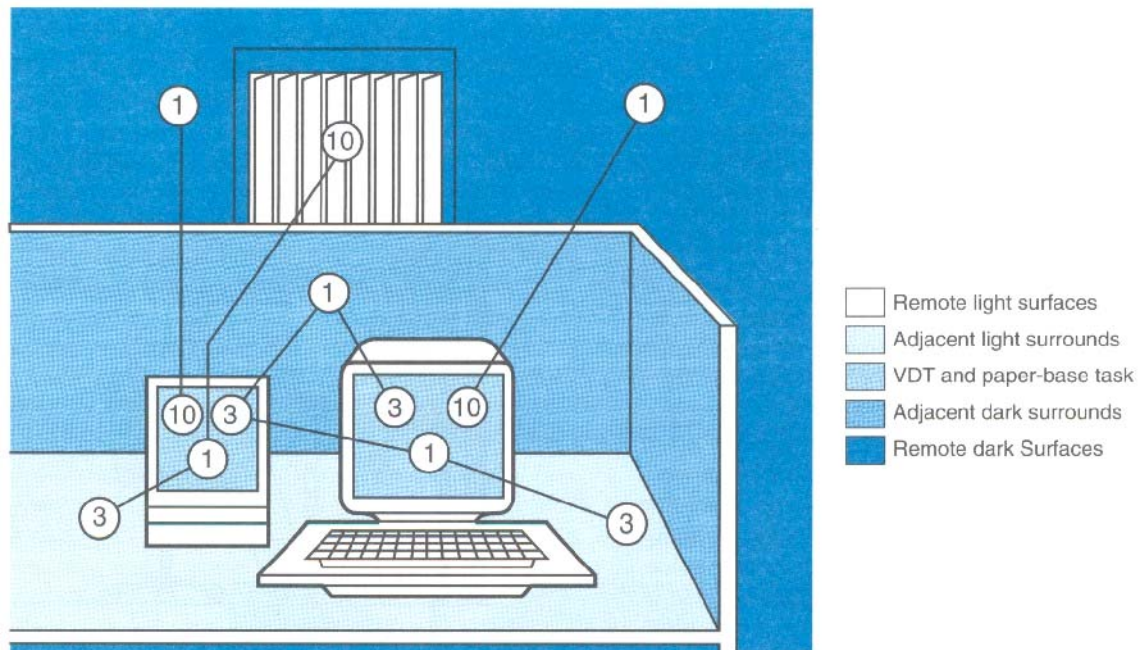


Fig. 2. Maximum luminance ratios recommended for a VDT workstation. The values joined by lines illustrate the maximum recommended luminance ratios among various surfaces. *Source: IESNA Lighting Handbook, 2000.*

The literature reviewed about the use of daylight in offices will be useful to check whether the results of the advanced daylighting system tested reach the illumination requirements for an office space with respect to uniform ambient lighting, task lighting, and visual comfort.

### 2.1.2. Effects of Daylight in Building Occupants

Daylight affects humans physiologically and psychologically. Physiologically, it influences the visual system and the circadian system that is the sleep/wake cycle and establishes variations in daily hormonal rhythms. Psychologically, it influences the perceptual system, producing changes in mood and social behavior (Boyce et al, 2003). Figure 3 shows graphically how lighting conditions influence human performance.

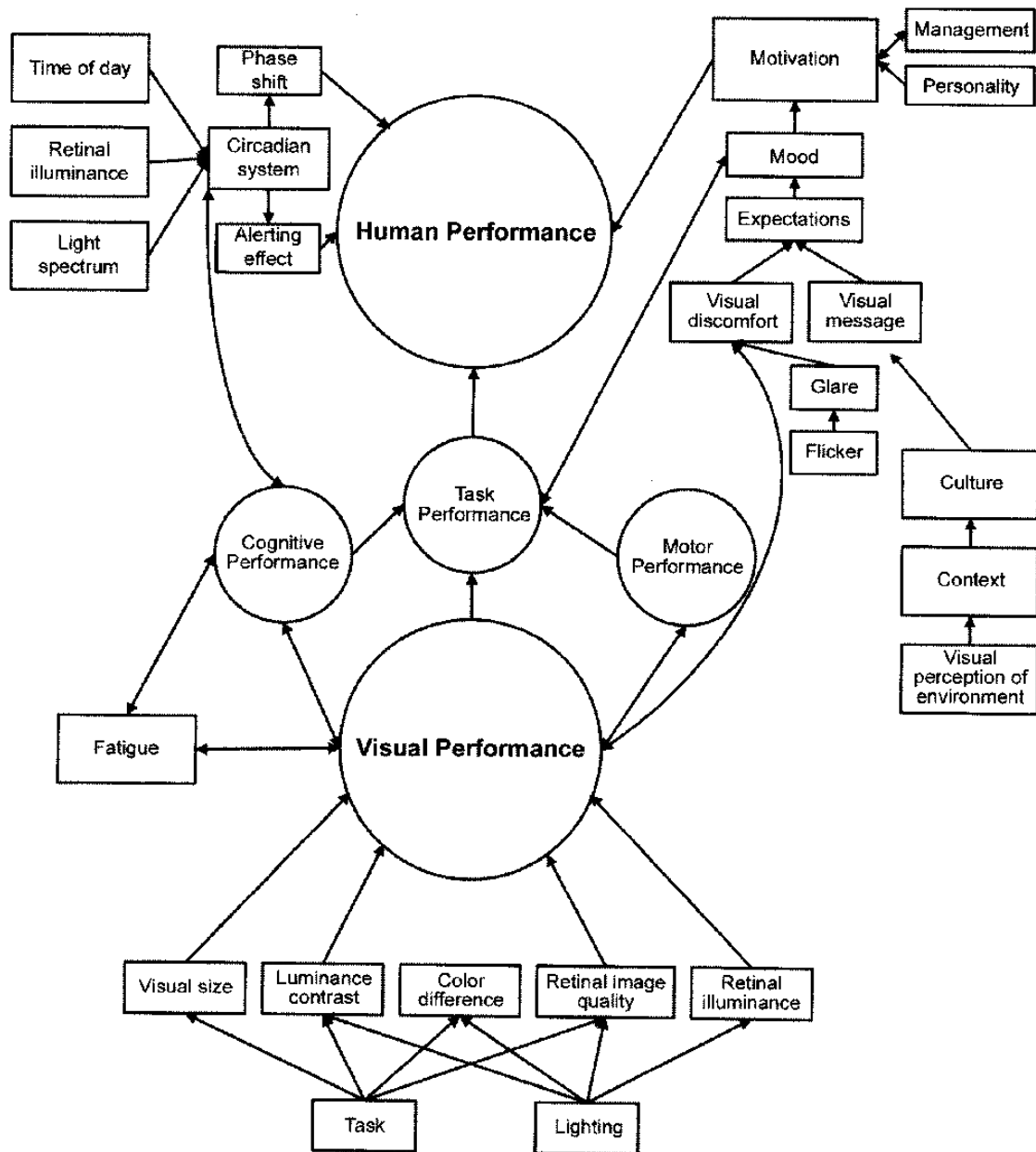


Fig. 3. A conceptual framework setting out the three routes whereby lighting conditions can influence human performance. *Source: Human Factors in Lighting by Peter Boyce, 2003.*

People like to work in a daylit environment that is connected to the changes of the outside world within the limits of visual and thermal comfort and privacy conditions. A statistical study performed by the Heschong-Mahone Group showed that in six out of



eight cases, workers who had a window with a view performed better than those who had no view. It also found that office workers responded 10% to 25% better in memory and mental tests when they had a view outside in comparison to those who had no view at all. In addition, the employees with better health conditions were coincidentally those with better views in their offices. In the same study, some other conditions that affected the performance of office workers negatively were high cubicle partitions and glare from windows (Heschong-Mahone Group, 2003a; Heschong-Mahone Group, 2003b).

Several surveys recognized two distinctive factors contributing to office workers' satisfaction with the environment and high productivity. One was the individual control over windows. The other was shallow buildings, which permitted cross ventilation and natural light, over deep-plan buildings, which depended on mechanical systems for ventilation and electric light in core areas (Boyce et al, 2003).

This research will attempt to correct this problem of deep-plan buildings by bringing natural light to the back of the space. This will help the people who work far from the windows to have a more comfortable work environment without high illuminance contrasts.

## **2.2. ADVANCED DAYLIGHT SYSTEMS**

### **2.2.1. Introduction and Classification**

Daylighting systems are supplementary optical devices that work either in addition to or incorporated into windows or other openings (Compagnon, 2002). They are designed to intentionally adapt the intensity and distribution of daylight in a space to meet the task requirements without glare. Daylighting systems work together with electric lighting strategies, including switching or dimming artificial light in response to daylight levels with the purpose of minimizing building energy impact and energy usage (Benya et al, 2003).

These systems are called advanced or innovative because most of them refer to new technology in the market, or materials and products still under research.

There are several classifications of daylight systems (Littlefair, 1996; Kischkoweit-Lopin, 2002). One that is based on their geometric characteristics divides them into three categories (Compagnon, R., 2002):

a) Reflectors and light-shelves: These refer to reflectors located in the interior or exterior of an opening with its same dimensions.

b) Integrated window elements: These refer to small optical elements assembled in a repetitive and planar arrangement parallel to the interior side of a window or integrated in a multiple glazing unit, between two glass panes. Examples within this category are prismatic elements, transparent insulating materials; miniature mirrored louvers, laser-cut panels, and holographic optical materials.

c) Light-guides: These are systems that convey natural light into core zones of a building (see point 2.2.2 for further information on this topic).

Currently, most of the systems used in buildings provide directional control over incident light but are limited in managing the correct balance and contrast, nor do they allow sufficient illumination in core areas (Selkowitz and Lee, 1998). There are new technologies under development that could accomplish these issues, but they need further exploration in order to have a final integration with the building marketplace.

## **2.2.2. Light Guides**

Light transport systems guide the light flux from the collector to the emitter by using a transmission medium. In this way, beamed sunlight can be channeled and distributed into interior spaces. Different technologies have been developed for that purpose. A description of some of them follows.

### **2.2.2.1. Remote lighting**

Some technologies use fiber optics (Wilson et al., 2002) and prismatic pipes (Whitehead et al., 1986; Aizenberg, 1997) to transmit the light beam (Figure 4). The main limitation of these methods is that they need a heliostat as collector to concentrate

the sunlight. Heliostats are expensive and require careful maintenance. For maximum daylight availability, they are placed on rooftops from where the light is directed into a vertical shaft and then spread as a network at different levels. For that reason, these systems need adequate upright spaces exclusively designed for their emplacement. Otherwise, it could be difficult to fit these long vertical elements into an existing structure and to integrate them into the architectural design, as in the case of retrofitted buildings.

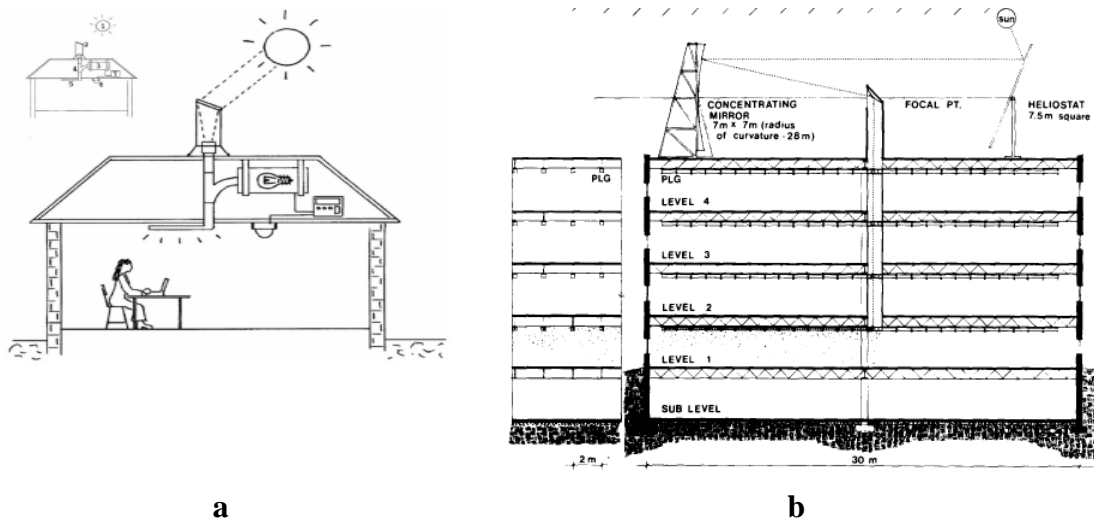


Fig. 4. Remote lighting. (a) UFO system with fiber-optics, (b) prismatic pipe with a heliostat collector. Sources: a) Wilson et al., 2002; b) Whitehead et al., 1986.

#### 2.2.2.2. Vertical light pipes

Other studies use vertical light pipe configurations. Although some of them interestingly combine daylighting with natural ventilation (Shao and Riffat, 2000; Oliveira et al., 2001), these solutions are limited to single-story buildings and top floors of multi-story buildings (Oakley et al., 2000; Carter, 2002; Jenkins and Muneer, 2003). Refer to Figure 5 for some examples.

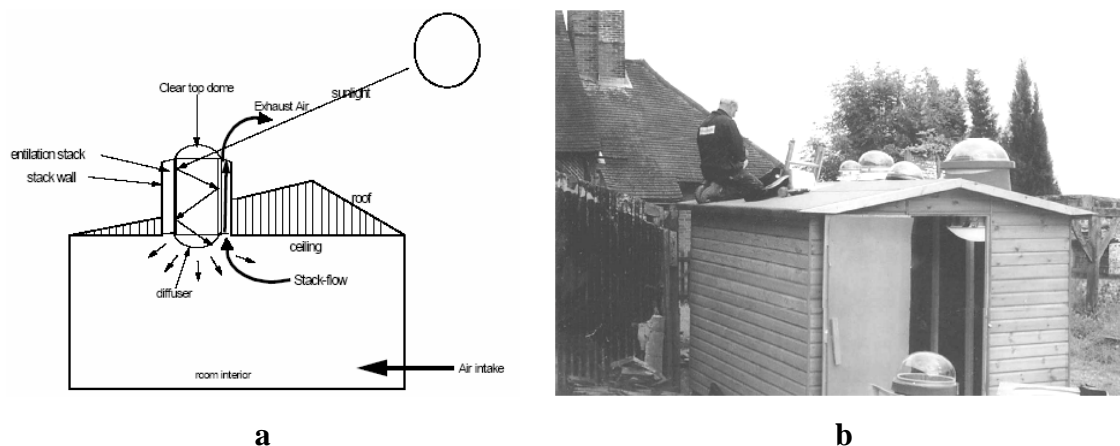


Fig. 5. Vertical light pipes. a) Combining daylight with natural ventilation, b) prototype useful only for single floors. Sources: a) Shao and Riffat, 2000; b) Carter, 2002.

### 2.2.2.3. Horizontal light pipes

Horizontal light pipes designed for sunny and partly sunny skies are a promising solution for supplementing daylight in deep-plan buildings. One of the most important advantages is that they can fit into ceiling plenums, making them appropriate for their integration into existing buildings. For better performance, horizontal light pipes need to be optimized for different latitudes and orientations.

A study conducted by the Lawrence Berkeley Laboratory (LBL) evaluates light pipes for intermediate latitudes with predominantly clear skies throughout the year (Beltrán et al., 1994; Beltrán et al., 1997). This system successfully captures and redirects sunlight from the façade towards the rear of the room, using reflective materials and optimized geometry. The results showed regular illuminance levels above 200 lux from 9am until 4pm throughout the year. The analysis was done for Los Angeles, CA (latitude 34° N).

Anidolic [non-imaging] ceiling is another type of remote source lighting but it is designed for mainly overcast conditions, typical of central European winters. It collects diffuse light rays coming from the sky vault and redistributes it into 21.5 ft deep rooms (Scartezzini and Courret, 2002; Courret et al., 1998).

Studies performed on light pipes in the tropics, where the sun can be either on the northern or southern hemisphere depending on the season of the year, propose light pipes facing east or west, which limits their use to only half of the day. One of these studies (Chirarattananon et al., 2000), conducted for Bangkok (lat: 13°45'N), basically develops a validation for a mathematical model that calculates daylight illuminance with ray tracing technique, and heat transfer with Reas's method (1993). A few details about the light pipe design and employed materials are also explained in the study.

Another study (García Hansen et al., 2001; García Hansen and Edmonds, 2003) develops a solution for a commissioned high-rise building in Kuala Lumpur (lat: 3°7' N). The orientation of the horizontal light pipes is towards the west. This research makes use of mirrored light pipes coupled with laser-cut light-deflecting panels (LCP) as sunlight collectors and diffusers. The principal drawback of this study is the use of LCPs as collectors. Although it is a good means for deflecting and redirecting the light towards the interior, it does not maintain the intensity of the light flux as it is received. Thus, it gives illuminance values in the range of 200-300 lux in the afternoon, acceptable for ambient light (which was required by the client), but not for task light. It also proposes further improvement in the light output devices for a more uniform light distribution.

One other study makes an annual simulation of horizontal light pipes for south-facing rooms in Venice (lat: 45.5° N) (Peron et al., 2004). The main difference of these light pipes, as opposed to those of the previous works, was that the reflector was a mechanical piece that varied in its inclination to better capture the sunbeam as the sun moved along the day. This light pipe and its moveable reflector were not built. Another limitation was that in order to obtain a uniform illuminance level at the work plane, the transparent glazing was reduced to 30% (from 10 m<sup>2</sup> at the reference case to 3 m<sup>2</sup>), significantly minimizing the view outside. For the simulation, the horizontal average illuminance used came from a Local Exterior Illuminance Model (LEIM) and not from real measurements, which resulted in an underestimation of the real values. Other than that, this study complied in terms of visual comfort, obtaining a uniform daylight distribution across the room with correct illuminance levels and contrast ratios.

The present research is based on the light pipe developed by LBNL exploration. The light pipe has been studied using scale models and computer simulations, showing adequate daylight levels at the back of the room with a minimum inlet glazing (not extra cooling loads). This design is applicable to the latitude and sky conditions of College Station (lat: 30° 36' N), where the actual research was conducted. This has been one of the reasons to select this work as opposed to others such as anidolic systems designed for overcast skies, or light pipes in the tropics meant for low latitudes. The other studies use either expensive technology with difficult maintenance (heliostat and fiber optics), moveable parts that complicate the system and have been only simulated (mechanical reflector), or inadequate materials to concentrate direct sunlight (Kuala Lumpur high rise building). Vertical light pipes have not been considered because they are meant for single floors, and that is out of the scope of this study.

## **2.3. DAYLIGHT EVALUATION**

### **2.3.1. Scaled Models**

The use of scale models is an invaluable tool in the design process of a daylighting system, allowing the assessment of its quantitative and qualitative characteristics. Quantitatively, due to the physical properties of natural light, the photometric measurements taken inside a physical scale model are the same as those existing in a full-scale building. That happens because the size of the light wavelengths, 380-780 nm, is small compared to the size of any scale model (Baker and Steemers, 2002). Qualitatively, a direct visual examination of the interior provides information about glare and contrast in the space. It also gives the possibility of taking pictures, which cannot be done by mathematical analysis (Robins, 1986). In general, scale models are flexible tools that allow the comparison of different configurations quickly.

The scale of the model depends upon the evaluation technique used and the level of data required. Large scale models (1:10 to 1:1) are especially useful to integrate industrial components, and to proceed to final evaluation of advanced daylighting

systems through monitoring and visual assessment of possible users and photographic records (IEA SHC Task 21, 2000).

Important considerations when building a model are the accurate geometric reproduction of the space and the replication of the transmission properties of glazing materials and the reflectance of the different surfaces (Spitzglass, 1983).

The decision to use scale models in the present study allowed changing settings in a quick fashion and experimenting with different materials and solutions with real weather data. The materials and the large scale of the model facilitated in the observation of the daylighting system, making it as close as possible to a real space.

### **2.3.2. Photometric Evaluation**

For an efficient photometric evaluation, some considerations must be followed. It is important to take continuous readings of exterior illuminance while taking interior illuminances to obtain daylight factors. The light meters or photometric sensors must be chosen according to the range of light to be measured –0-40,000 lux for diffuse light and 0-120,000 lux for direct light– and they should also have a photopic filter as well as cosine correction. For the layout of the interior sensors, different schemes can be arranged: a single point, a line, or a grid. A grid has to be uniformly spaced in columns and rows, and it is used primarily to obtain illuminance contour maps (Robins, 1986).

The best testing times under a clear sky are between 9am and 3pm. Additionally, it is useful to consider the beginning and the end of a working day, that is, 8am and 5pm. For a good study on penetration and distribution at least three times should be considered: 9am, 12pm, and 5pm (Robins, 1986).

All of the above factors were considered in the present study, including the use of adequate photometric sensors that were placed on a grid, frequent measurements of interior and exterior illuminances, and the appropriate schedule for an office building.

### 2.3.3. Lighting Quality and Visual Comfort Evaluation

A great deal of research regarding lighting quality assessment that involves luminance mapping and glare analysis has been done.

Mapping systems based on CCD (Charge-Coupled Device) technology have replaced the old method of acquiring luminance maps with spot luminance meters. Using this digital technology, it is possible to convert pixel values to luminance values. A study (Berrutto and Fontoynt, 1995) proposes the use of CCD systems to evaluate discomfort glare indices. Another study presents the calibration of a Nikon digital camera for acquiring luminance maps (Coutelier and Dumortier, 2002), which resulted in the development of licensed software, PHOTOLUX. But this becomes to be an expensive solution for academic purposes. Software that is more suitable is “HDR Shop” for PCs developed by P. Debevec (2001), and “Photosphere” for MACs by G. Ward. Both programs deal with high dynamic range –HDR– images (Debevec and Malik, 1997; Ward, 2001). A HDR image is the combination of multiple photographs of a scene at different exposures that capture a much greater range of light than single exposures. It is much closer to what a human eye perceives. This is possible because HDR pixels use floating-point numbers, capable of representing light quantities of 1 to 1,000,000 and beyond. On the other hand, digital cameras apply nonlinear mapping to convert the 12-bit output from the CCD into 8-bit values commonly used to store images, losing valuable data in the process. These types of images store pixel values as integers from 0 to 255.

A method to evaluate brightness distribution and glare potential, based on measured luminance variations within a space, proved to be useful for predicting occupant response (Schiller and Japee, 1995). This method was further supplemented with the development of a software package that makes it functional and easy to use (Culp, 1999). The inconvenience of this method is that the graphic represents the picture in pixel values, which makes it hard to compare with the iso-contour images that show the photograph in  $\text{cd/m}^2$ .



To validate the luminance values in the images of this study, HDR images composed in Photosphere and processed in Desktop Radiance as iso-contours, were compared to luminance measurements taken at the real space. Further explanation about the method used to evaluate visual comfort is in Chapter III.

#### **2.3.4. Visual Observation**

Because no instrument can duplicate or measure what the human eye perceives, visual observation is critical in the qualitative evaluation of a daylighting system. Usually, people's opinions about the visual performance of a lighting system are taken in the design stage, or later as a post-occupancy evaluation (POE).

When used in the design stages, visual observation generally involves the inspection of the scale model where the daylighting system is being studied. For that purpose, viewing ports need to be placed at a scaled eye level. Looking inside the model, and before any evaluation is done, the observer has to allow his eyes to adjust to the interior light levels for at least 5 minutes. Before that adjustment period, the person should evaluate the lighting conditions as soon as possible, as the first impression is important (Robins, 1986). When evaluating a new system, it is important to have a neutral reference model or base case so the person can compare between this and the new solution (IEA SHC Task 21, 2000).

The primary aim of a POE study is to know whether the lighting design meets the expectation levels that were intended during its development (Baker and Steemers, 2002).

In both cases, used in the design stage and as POE evaluation, the opinions of people can be collected in a questionnaire or survey. Surveys are an important tool for the assessment of a user's opinion (Hygge and Löfberg, 1999; IEA SHC Task 21, 2000; Heschong Mahone Group, 2003a).

This study used a survey as an evaluation method for the light pipes advanced daylighting system. It involved the observation of the reference model and the test model through viewing ports placed on the sides of each model.

All these assessment techniques have been used in combination to evaluate the advance daylighting system tested in this research. The use of scale models to take photometric measurements collectively with photographic documentation and visual observation shapes the methodology followed in this study. A detailed development of this methodology is explained in the next chapter.

## CHAPTER III

### METHODOLOGY

#### 3.1. CONSTRUCTION OF PHYSICAL SCALE MODELS

##### 3.1.1. Scale Models: Design and Construction

This study follows the research started by Lawrence Berkeley National Laboratory, LBNL (Beltrán et al., 1997). Therefore, the prototype characteristics in this study aim to be as similar as possible to those in that study. The base case or reference case is a module of a multi-story office building with an open-plan configuration. The real dimensions are 20 ft width, and 30 ft length (deep-plan), and 10 ft ceiling height with 2 ft more for the plenum. To facilitate qualitative assessment, the scale of the models was decided as 1 foot = 3 inches. This scale gives an adequate depth of field for the photographic documentation and allows a realistic field of view for visual observation. It also has the advantage of being the appropriate scale for studying constructive details in the light pipe design. All the drawings displayed in this chapter show the measurements of the scaled models, not the measurements of the real scale.

The floor and walls were constructed of plywood, water-sealed, and painted. The ceiling, made with corrugated board, was mounted on a wooden structure. It was slid into the model and supported by three tight cables placed between the side walls. The three different surfaces were painted, and their reflectances are shown in Table 2.

The reflectance  $\rho$  for each material was calculated as follows:

$$\rho = [(L \times 0.18 / L_{GC}) + (L \times 0.9 / L_{WC})] / 2 \quad (1)$$

where  $L$  is the luminance value of each material measured with the luminance meter,  $GC$  is the known reflectance of a Kodak gray card with a value of 18%, and  $WC$  is the known reflectance of a Kodak white card with a value of 90%.

Table 2

Floor, ceiling, walls, and furniture reflectances

Physical model components	LBNL reflectances	Thesis reflectances
Floor	0.21	0.23
Wall	0.44	0.47
Ceiling	0.76	0.80
Furniture	N/A	0.34

*\*Measured with a Minolta LS-100 luminance meter in overcast conditions.*

The façade was made of stackable parts to facilitate the easy removal of these parts for exploration of different designs and materials, and for re-design and use in future studies. These parts were the window sill, lower window, upper window, and plenum front-part. This last piece varies in the test case, with a protrusion in the middle with a small sloped glazing aperture that is the light pipe collector. Figure 6 shows the plan view, and Figure 7 shows the section of the reference model. Figure 8 shows the details of both façades. The windows have clear glass,  $\tau = 88\%$ , and three layers of white paper applied from the inside. The total transmittance in the models is 14%, which approximates to the real conditions commonly found in office buildings consisting on double-pane low-E glass,  $\tau = 77\%$  (LBNL, 2005), with closed white Venetian blinds,  $\tau = 20\%$ , which corresponds to a total transmittance of 15% ( $\text{Total}_\tau = \text{Glass}_\tau \times \text{Blinds}_\tau$ ). The reference values for the venetian blinds transmittance were obtained from measurements taken with closed blinds,  $\tau_{cb} = 20\%$ , and opened / semi-opened blinds,  $\tau_{sob} = 29\%$  (refer to detailed tables of venetian blinds transmittance in Appendix A).

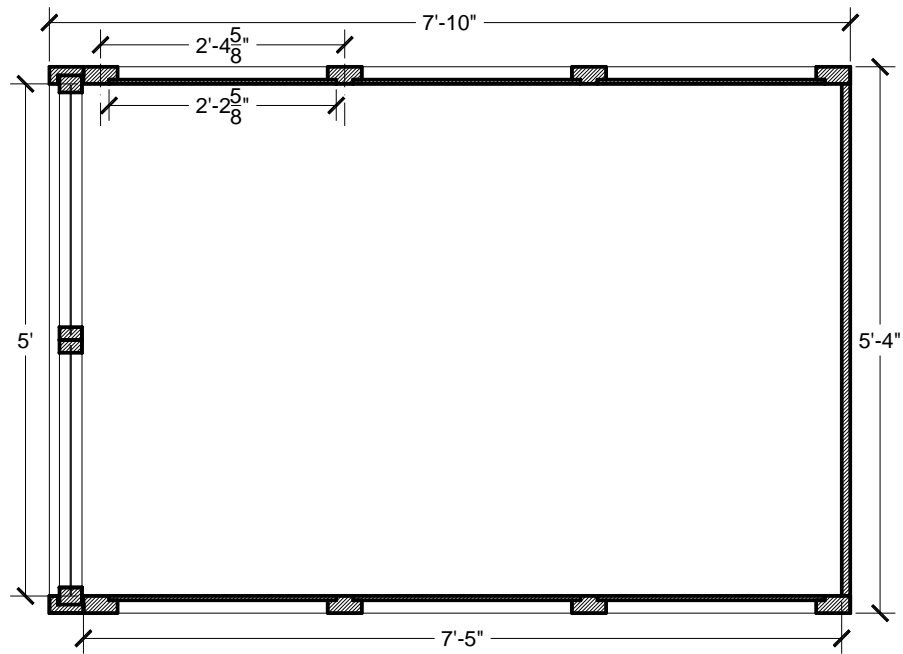


Fig. 6. Reference model plan view.

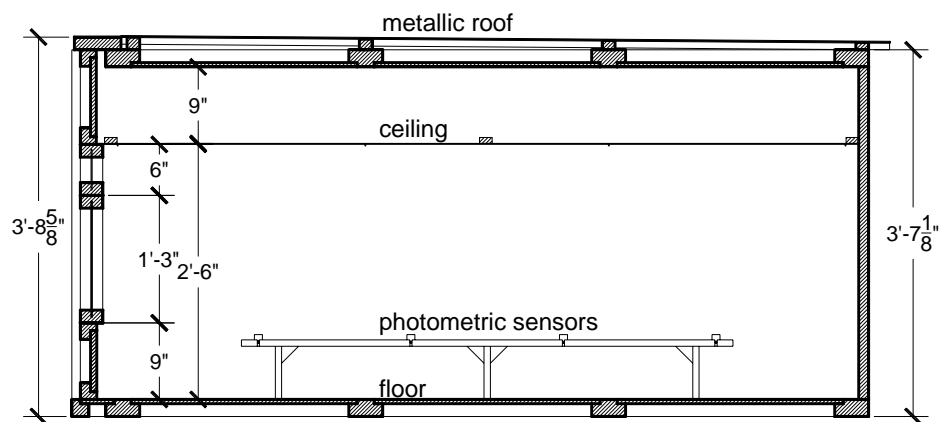


Fig. 7. Reference model longitudinal section.

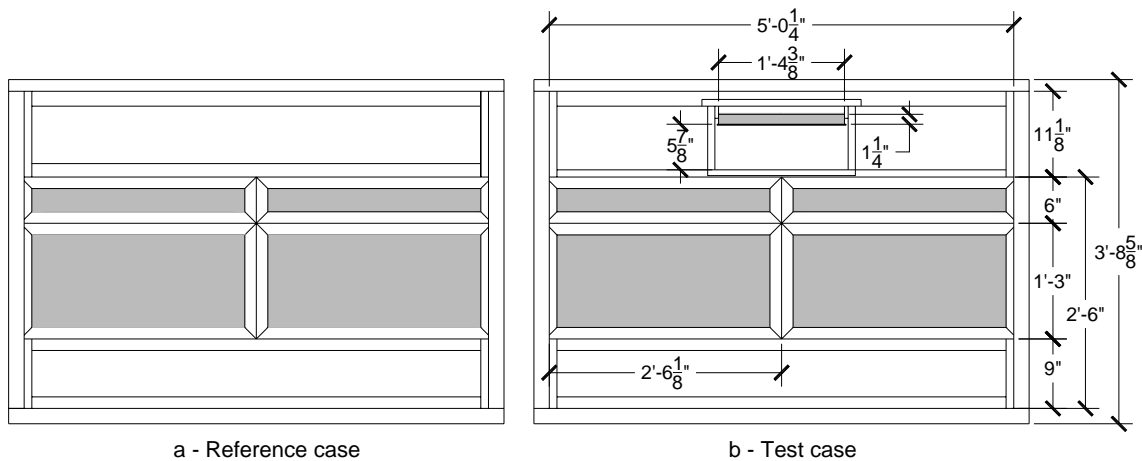


Fig. 8. (a) Reference model front view, (b) test model front view.

The two scale models, reference and test cases, were assembled side by side on a metallic platform on the roof of the School of Architecture, Texas A&M University, located in College Station, TX. The models were placed and leveled on top of concrete blocks for better access and appearance. Figure 9 shows a picture of the final setting. The facades of the scale models are facing south. Since the platform is metallic and a compass would not work, the true North was found by marking the shadow of a plumb line at solar noon for 10 days. The line obtained indicates the axis North-South as shown in Figure 10.

In order to have visual access into the models, three viewports at eye level were provided on each scale model: one at the back and two on the east facing wall. These viewports give two different points of view as well as the possibility of performing several tasks at the same time, like taking pictures and luminance measurements simultaneously.



Fig. 9. Experiment layout on Langford building's roof.



Fig. 10. Setup to find North-South axis at solar noon.

### 3.1.2. Light Pipe Prototypes: Materials, Design and Construction

The prototype developed has a trapezoidal shape in plan and has been tapered in its longitudinal section towards the rear of the room. The depth of the ceiling plenum determined its size so that the light pipe could fit inside it. The length is 31.7 ft, the width varies from 6 ft at the front to 2 ft at the back, and the height varies from 2 ft at the front to 1 ft at the back. The light pipe design in plan and section is shown in Figure 11 and Figure 12, respectively.

The light pipe captures the sunbeam through a small glazing area and guides the incoming sunlight from the collector towards the emitter through a transport section.

The collector is made to collimate incoming sunlight, optimizing the amount of bounces the light makes through the transport section. It consists of a protruded volume that projects 1 ft outside the façade plane with a glazing area in its upper part. The glazing has a transmittance coefficient of  $\tau = 88\%$ . The collector consists of fixed central and side reflectors designed according to the angles of the sun in the solstices and equinoxes. The central reflectors are meant to capture the daylight from approximately 10am to 2pm. They were designed with the solar altitude angles at solar noon for the equinoxes, winter solstice, and summer solstice, as shown in detail in Figure 13. The objective of the side reflectors is to capture sunbeams in oblique angles during early morning and late afternoon hours. For the design, the azimuth angle is  $60^\circ$  and, the altitudes are  $40^\circ$  for equinoxes and  $78^\circ$  for summer solstice, as can be seen in Figure 14. The altitude angles were found by using a sun path diagram drawn with the software “Sun Path,” version 1.0 (beta), distributed by Pacific Gas and Electric Company (refer to sun path graph in Appendix B).



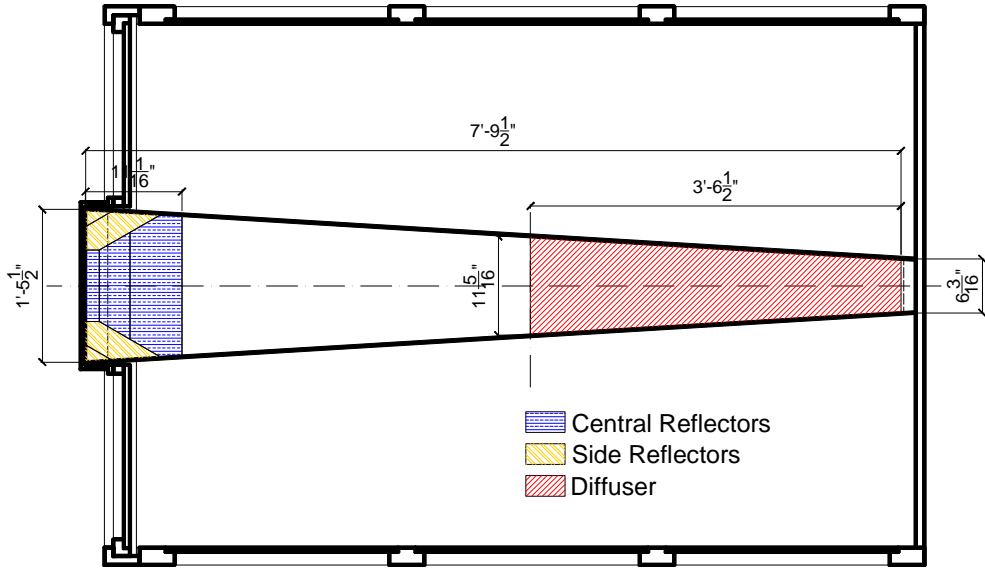


Fig. 11. Light pipe design in plan view.

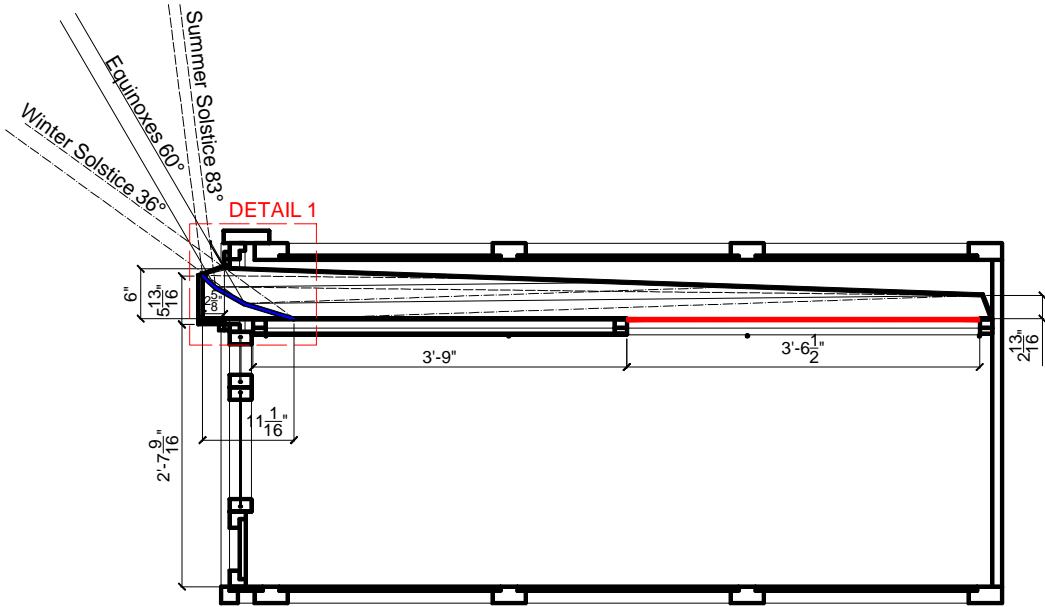


Fig. 12. Light pipe design in section.

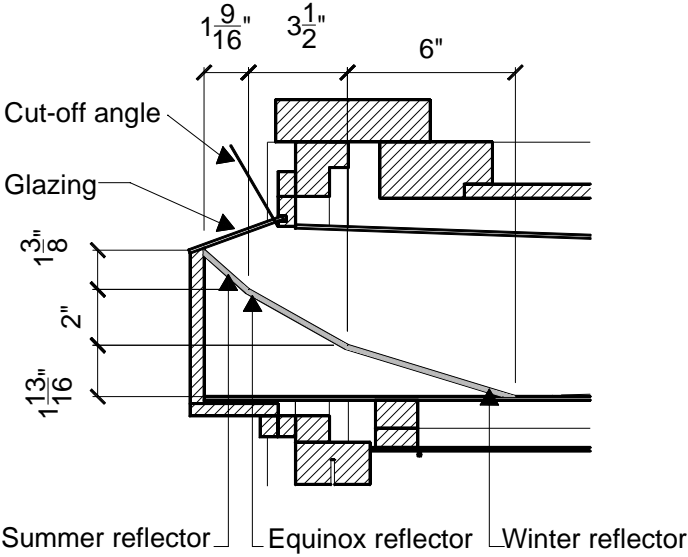


Fig. 13. Detail of central reflectors.

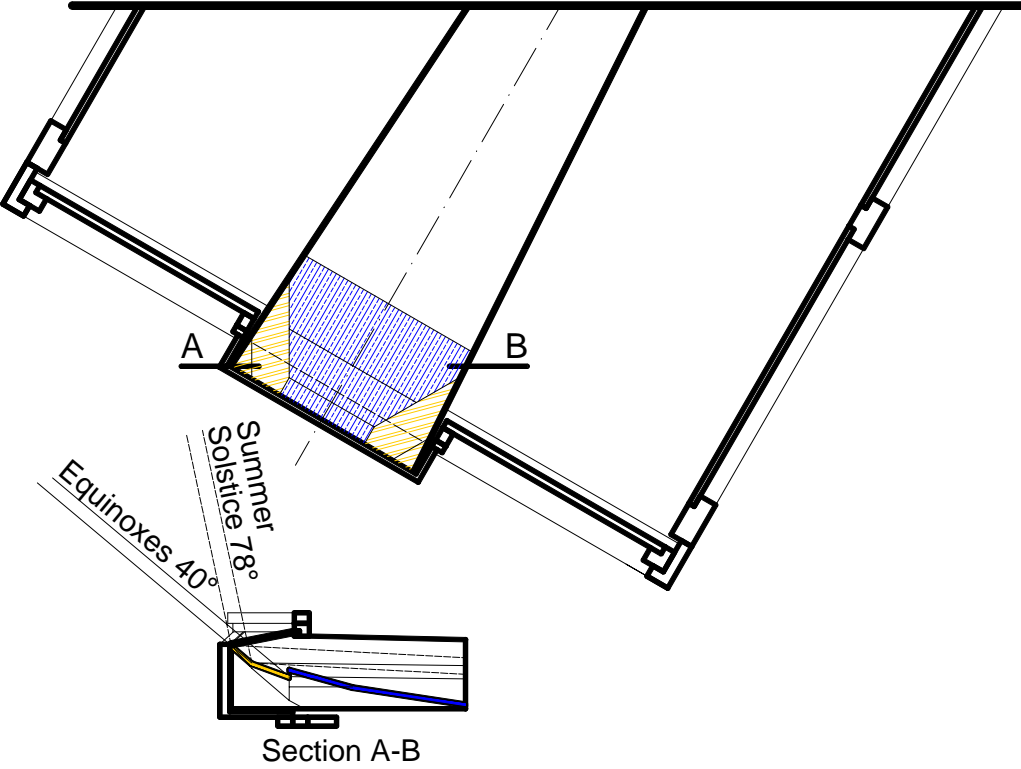


Fig. 14. Design of side reflectors for oblique sun-angles.

The transport section consists of a pipe coated with a reflective material, with an opening in the bottom of the second half of its length for the distribution of the light into the room. This element was made of corrugated board layered with poster board for a smoother surface, and was covered on all its surfaces with a high reflective film. The reflective film used in this study is “Silver Reflector III” by Southwall Technologies, with a specular reflectance  $\rho > 95\%$ . A data sheet with specifications about this product can be found in Appendix C. This material was the result of an extensive search for high reflective films with a specular reflectance  $\geq 90\%$ , and an adhesive side for an easier application. Nothing was found with both characteristics; the product lacks an adhesive side. This resulted in inconvenience at the time, since attaching the film to the poster board cause it to reproduce the texture of the board, losing reflectivity. A study was conducted to find the mounting technique with the best specular reflectivity. The procedure followed is described in Appendix D. The solution adopted was to stretch the film, attaching it only to the edges with removable adhesive.

The emitter, placed at the ceiling level on the second half of the light pipe, consists of an opening with a diffusing material to transmit the daylight. The diffuser needs to distribute uniformly the greatest amount of light without causing glare problems. The diffusers used were: a) white color Barrisol® stretch ceiling, a lightweight, lead-free co-polymer easy to stretch,  $\tau = 34\%$ ; and b) translucent Mylar® drafting polyester film,  $\tau = 70\%$ , thickness 0.06mm. Tests for observing the raw output and the patches of light were run with both diffusers as well as with the opening completely void. Obstructions were checked by taking photographs with a fish-eye lens. The camera was placed on top of a tripod at the middle of each facade plane. Pictures were taken at window sill-level for both models, and at the light pipe collector level for the test model. A sunpath diagram, as shown in Figures 15 and 16, was superimposed on each photograph to find out when the scale models would be shaded by existing buildings and objects nearby. For both models the shaded time is early in the morning until 8am in winter and until 7am in summer, and in the afternoon from 4:30pm in summer.

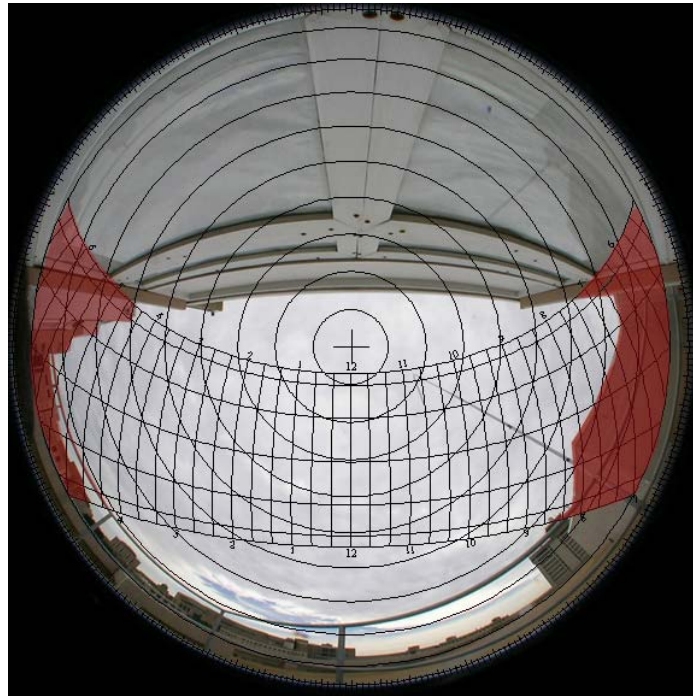


Fig. 15. Reference model 360° photograph with superimposed sunpath for College Station (30°36'N).

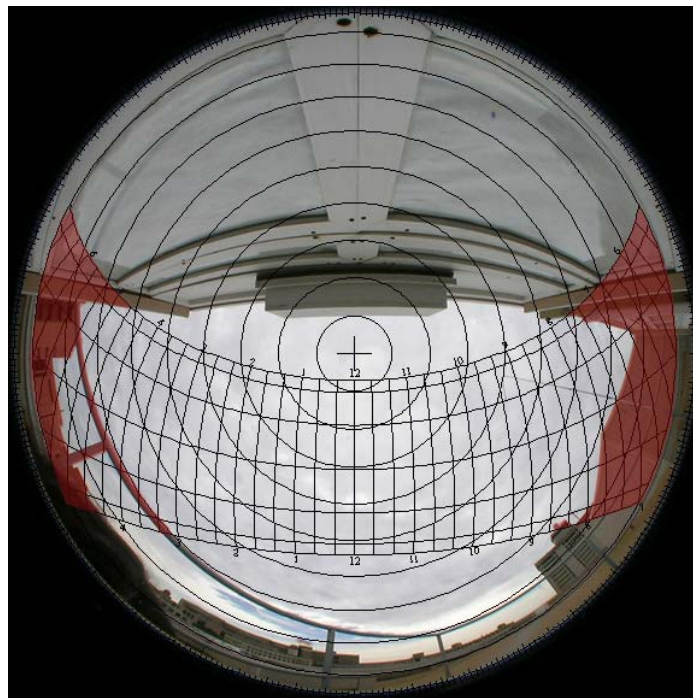


Fig. 16. Test model 360° photograph with superimposed sunpath for College Station (30°36'N).

Since the light pipe system works to capture sunlight under clear and intermediate sky conditions, sunlight availability was checked to confirm its appropriateness for the location under study, College Station, TX (30°36'N). Weather data from the National Oceanic and Atmospheric Administration (NOAA) regarding annual percentage of cloudiness is shown in Table 3 for Austin, TX (30°16'N), a location near College Station (NOAA, 2004). For College Station itself, the annual percentage of cloudiness extracted from NOAA is restricted to year 2003 and is shown in Table 4 (NOAA, 2005). According to NOAA data, it can be seen that the annual percentage of sunny and partly cloudy days ranged from 63% to 81% for this area. Another reference consulted regarding sunlight availability for a near location, Fort Worth, TX (32°47'N), shows that for the 7am-7pm time frame, the percentage of the year that is sunny is 66% (Robbins, 1986). This last reference is based on a prediction model. Consequently, according to Table 5, College Station climate could be categorized as average-clear (Robbins, 1986). Due to the limited data, all this information has to be taken as simply a reference. For detailed and extra tables, refer to Appendix E.

Table 3  
Annual cloudiness for Austin, TX, with 54 years of data collected

Cloudiness - Mean Number of Days (Clear, Partly Cloudy, Cloudy)	# of YRS	ANNUAL			ANNUAL
		CL	PC	CD	% of CL+PC
AUSTIN, TX	54	115	114	136	63

Table 4  
Cloudiness for College Station, TX, for the year 2003 only

Cloudiness - Mean Number of Days (Clear, Partly Cloudy, Cloudy)	YEAR	ANNUAL			ANNUAL
		CL	PC	CD	% of CL+PC
COLLEGE STATION, TX	2003	199	97	69	81

Tables 3 and 4 show the mean number of days per category of cloudiness. The categories are determined for daylight hours only. "Clear" denotes zero to 3/10 average sky cover. "Partly cloudy" denotes 4/10 to 7/10 average sky cover. "Cloudy" denotes 8/10 to 10/10 average sky cover.

Table 5  
 Cloud Cover categories according to sunlight probability data bins by Robbins, 1996

Characteristic Climate	Sunlight Probability
Very Clear	> 0.85
Clear	> 0.75
Average	> 0.65
Overcast	> 0.55
Very Overcast	< 0.55

### 3.2. EVALUATION METHODS

The performance of the light pipe was assessed quantitatively by taking illuminance and luminance measurements, and qualitatively by visual inspection and pictures.

#### 3.2.1. Data Collection with a Datalogger and Photometric Sensors

The instrumentation used to collect illuminance levels consisted of twenty-eight photometric sensors by LI-COR, model LI-210SA; a shadow band stand by Eppley Laboratory, model SBS; and a datalogger by Campbell Scientific Inc., model CR23X. For the LI-COR sensor calibration, two Konica-Minolta light meters, models T-10 and T-10M, were used. Specifications about this equipment are documented in Appendix F.

The LI-COR photometric sensors are cosine-corrected. Twenty new and eight old sensors were slightly adjusted for natural light, using overcast sky as the most accessible uniform condition. At the same time, they were calibrated using two Konica-Minolta light meters. For detailed tables of the calibration process, see Appendix G.

For the interior measurements, twelve sensors were placed in each model. They were distributed on a grid of three by four lines at workplane level and mounted on top of wooden racks. The mounting racks had holes to receive the sensors, with a notch for the cables. They were painted gray with a 0.34 reflectance, since this is the color commonly used for office furniture. The arrangement of the sensors is shown in Figure 17. Outside the models, four photometric sensors LI-210SA were placed to measure

external illuminance. Two of them were mounted on a post next to one of the models to take horizontal and vertical global illuminance. The other two were positioned horizontally and vertically in a static shadow band to measure diffuse illuminance (excluding direct sunlight). The shadow band stand was placed facing south, and its purpose was to block the direct sun from shading the sensors. It had to be adjusted regularly to coincide with the solar declination. This feature was set on the last stage of the experiment, and the data available is valid for only the Mylar® diffuser. The pictures in Figure 18 show the four sensors placed in the exterior.

The datalogger used for collecting the data was set to make readings every minute of the illuminance levels. This gave the flexibility to manipulate data as required at a later stage. The program to collect data was written using the software SCWIN version 2.0 (Beta), and was later adjusted using LoggerNet version 2.1.0.15, both softwares by Campbell Scientific Inc. The data collection was performed weekly, using LoggerNet software. A detailed input of the data collection program, as well as considerations to have in mind when writing a datalogger program, was included in Appendix H.

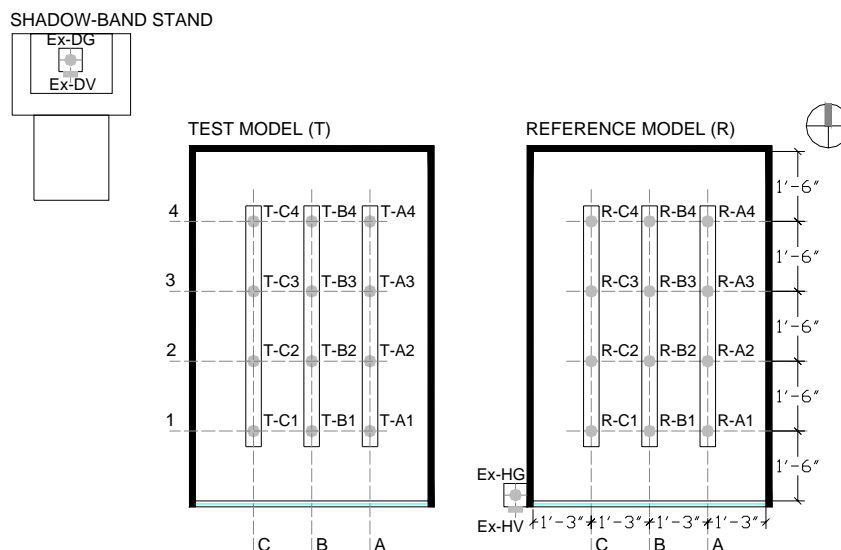


Fig. 17. Arrangement of sensors inside and outside both models.

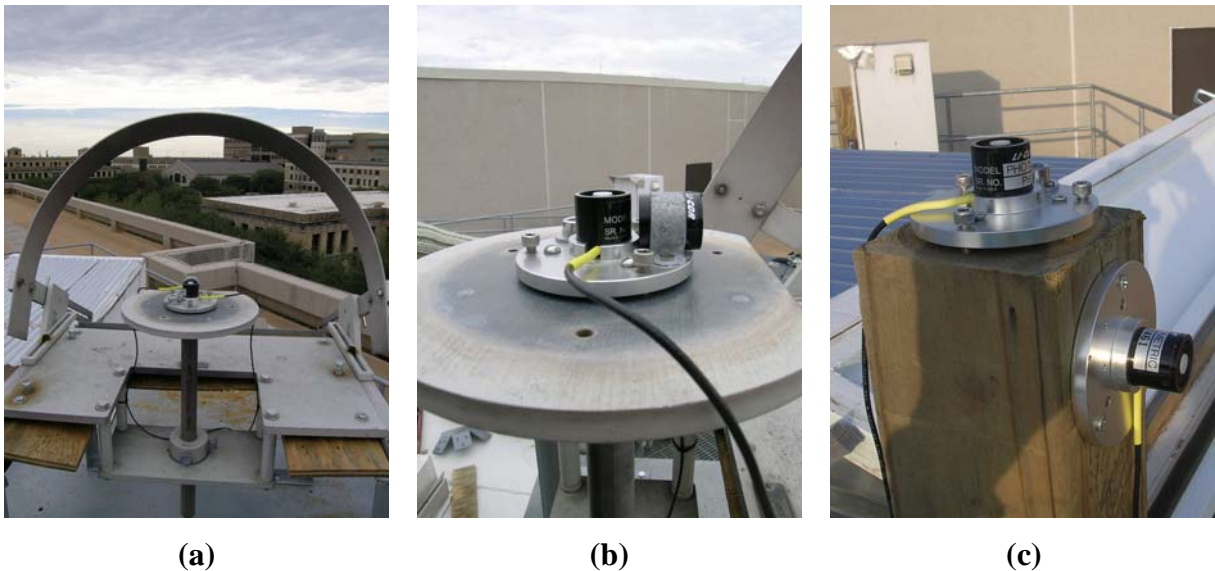


Fig. 18. Exterior photometric sensors. (a) Shadow band oriented South for obtaining horizontal and vertical diffuse illuminance, (b) Horizontal and vertical sensors placed in the shadow band, (c) Horizontal and vertical sensors for global illuminance placed on top of a post and next to the reference model.

This experiment involved two instances. In the first instance, the windows received a layer of white paper simulating semi-opened Venetian blinds. The second instance consisted of adding two more layers of paper simulating closed Venetian blinds, which is a more common condition in open-plan office buildings in order to avoid direct sun on computer screens and to reduce heat gain. The survey was taken during the first instance. However, the second instance is the one chosen for further analysis. In order to analyze the measurements taken on clear days during the first instance, three layers of paper were placed at the window of the reference model, and the light pipe collector was closed in order to simulate a base case with closed blinds, while the reference model was left with only one layer of paper to simulate semi-opened blinds. Measurements were taken for several days under clear and overcast days. A correction factor of 0.4076 for clear days was deducted to adjust the values of the first instance that were needed in the analysis. More details appear in Appendix J. After this test was performed (03/08/05), both models were left with 3 layers of papers, simulating closed blinds.



To obtain the contribution by itself of the three light pipe conditions, the windows of the test model were covered at different times with black plastic, while keeping the windows of the reference model uncovered.

### **3.2.2. Visual Assessment**

Glare, contrast, and visual comfort evaluation were assessed by photographic documentation, luminance measurements, HDR composition, and direct visual observation by the author herself and by means of a survey.

#### **3.2.2.1. The use of luminance ratios and photographic documentation for visual comfort evaluation**

A time-lapse sequence was recorded to observe the change in the sun pattern throughout the day when testing the light pipe without diffusers (void opening).

High Dynamic-Range (HDR) images were created from multiple bracketed exposures of the same static scene. The purpose of HDR images is to reconstruct the image of the scene closer to reality than a common picture. The software “Photosphere” by Greg Ward was used to create these types of images. Luminance contour maps of these HDR images were obtained afterwards using Winimage version 1.0, the image analyzer included in the Desktop RADIANCE package. Luminance measurements of reference points, to be compared later with the luminance maps, were taken at the same time as the bracketed photographs. Finally, luminance ratios were compared to those recommended in the IESNA Lighting Handbook (IESNA, 2000) for the visual comfort evaluation. Possible glare problems (direct and reflected) were also evaluated (ANSI/IESNA RP-1-04, 2004). The equipment used in this process was a digital camera, Nikon Coolpix 5400; and a Minolta luminance meter, model LS-100 (see Appendix F).

### **3.2.2.2. Survey for human response evaluation**

A survey was conducted to establish the effectiveness of the Light Pipe system. The objectives of this survey were to corroborate if the advanced daylighting system under study had achieved the following: increase in daylight levels at the rear of deep rooms, more uniform distribution of the light within the space, control of direct sunlight, and reduction in glare problems. The survey was conducted over two consecutive days with varied weather conditions (partly cloudy and sunny with haze). The nineteen participants consisted of graduate students and staff at Texas A&M University. The procedure involved observation of the interior of the two models (the reference case followed by the test case) through the lateral viewports, and the answering of a questionnaire. At the time each participant was observing, multiple bracketed exposures and luminance measurements of the test case and sky conditions were taken. Scaled office desks were included to give more realism and a sense of scale. Survey documentation and the questionnaire are presented in Appendix I.

## CHAPTER IV

### DATA ANALYSIS

This chapter discusses the data collected and the results obtained by following the methodology explained in Chapter III. The light pipe system is analyzed in three different output conditions. Condition one is the light pipe, called “raw”, which is the transport section without any diffuser at the output portion; condition two is the light pipe with a diffuser called Barrisol®, and condition three is the light pipe with another type of diffuser called Mylar®.

The three conditions were compared to the reference model and among themselves. They were evaluated through: a) exterior and interior illuminance measurements; and b) photographic documentation, some of it consisting of HDR images in combination with interior luminance measurements and time-lapse sequences. In addition, condition three was evaluated by means of a survey.

#### 4.1. MEASUREMENTS UNDER CLEAR SKY CONDITIONS

Illuminance levels were measured from December to March for the three light pipe conditions. As shown in Table 6, workplane illuminance at 24 ft due to the light pipe and the window contributions is over 300 lux from 10am to 2pm for raw light pipe from December to March; from 9am to 3pm for light pipe with Mylar® during January and February; and from 10am to 2pm for light pipe with Barrisol® in January and March. The glazing area at the collector is the same for the three light pipe conditions: 5.5 ft<sup>2</sup> in real scale, which accounts for only 0.91% of the floor area.

Table 6  
Workplane illuminance (lux) of the three light pipe conditions at 24 ft, with lower window contribution

<b>Raw Light Pipe</b>	<b>Dec. 26th</b>	<b>Jan. 17th</b>	<b>Feb. 25th</b>	<b>Mar. 08th</b>
8:00 AM/4:00PM	115	152	138	102
9:00 AM/3:00PM	263	314	267	240
10:00 AM/2:00PM	422	446	434	433
11:00 AM/1:00PM	574	591	553	606
12:00 PM	4221	1560	935	1002
<b>Mylar Light Pipe</b>	<b>Dec.</b>	<b>Jan. 25th</b>	<b>Feb. 14th</b>	<b>Mar.</b>
8:00 AM/4:00PM	N/A	140	171	N/A
9:00 AM/3:00PM	N/A	309	337	N/A
10:00 AM/2:00PM	N/A	554	581	N/A
11:00 AM/1:00PM	N/A	823	843	N/A
12:00 PM	N/A	1390	1233	N/A
<b>Barrisol Light Pipe</b>	<b>Dec.</b>	<b>Jan. 24th</b>	<b>Feb.</b>	<b>Mar. 11th</b>
8:00 AM/4:00PM	N/A	101	N/A	109
9:00 AM/3:00PM	N/A	273	N/A	219
10:00 AM/2:00PM	N/A	471	N/A	387
11:00 AM/1:00PM	N/A	634	N/A	571
12:00 PM	N/A	731	N/A	656

Figures 19 and 20 display the distribution of daylight in plan view, combining light pipe and window contributions for two light pipe conditions, with Mylar® and with Barrisol® diffusers. In both cases the improvement on the back part of the space compared to the reference case can be appreciated, as the space had illuminance levels of 300 lux and up from 9am to 3pm with Mylar, and from 10am to 2pm for Barrisol. This shows that the light pipe system has a noticeable performance throughout the greatest part of the working hours, with the highest values at noon, and with acceptable levels during morning and afternoon hours; hence, capturing the sun at oblique angles. The values from 10am to 2pm for Mylar, and from 11am to 1pm for Barrisol are a little high for an office with VDT screens, which is due primarily to the excess of light coming from the window that lacks a shading device to block the direct sun. Besides, the amount of light could be appropriate for other types of working environments, such as those requiring visual tasks of low contrast and small size, 1000 lux being the recommended illuminance value by IESNA (IESNA Lighting Handbook, 2000).

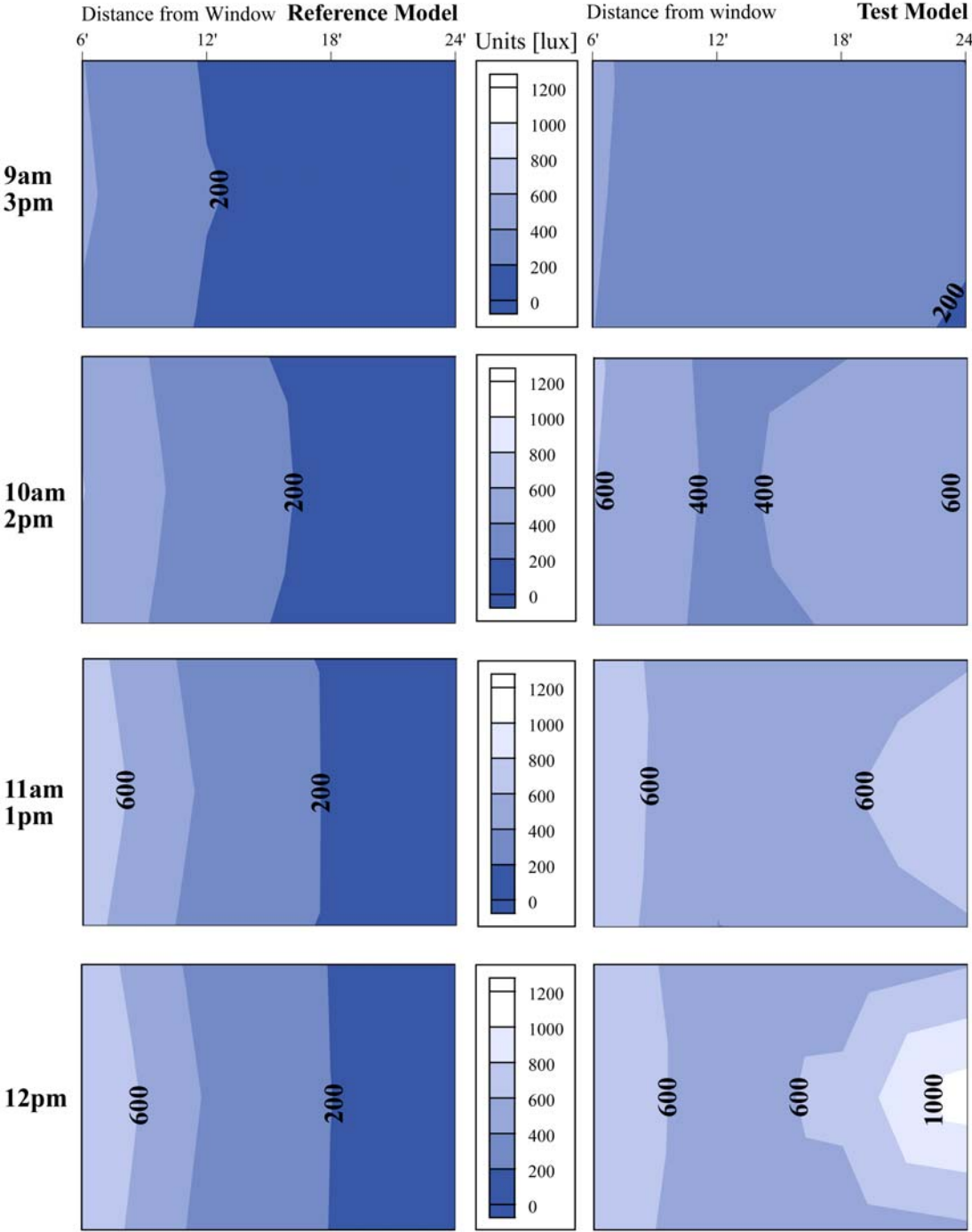


Fig. 19. Workplane illuminance (h: 28") distribution on February 14<sup>th</sup> for light pipe with Mylar® diffuser in test model.

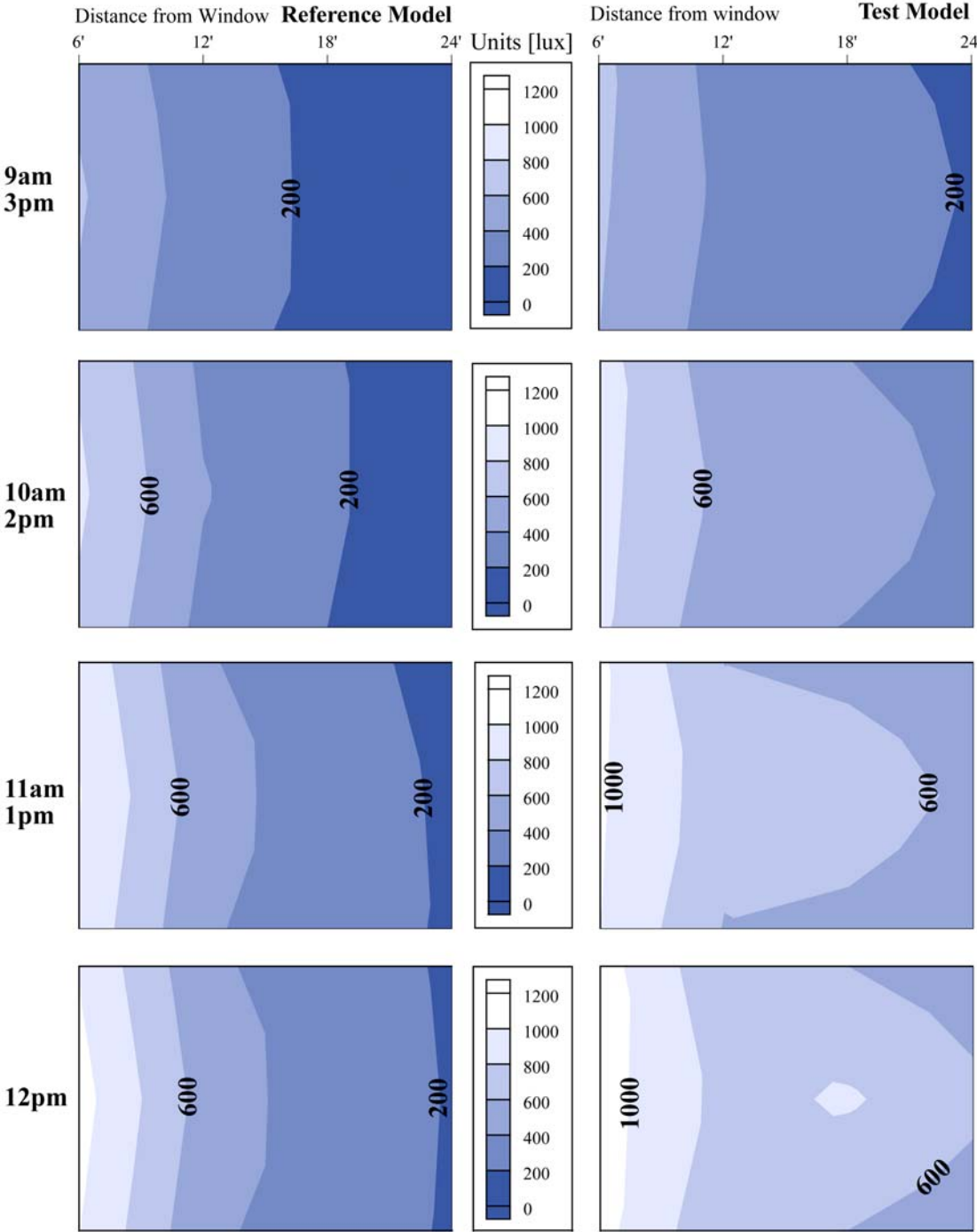


Fig. 20. Workplane illuminance (h: 28") distribution on March 12th for light pipe with Barrisol® diffuser in test model.

It can be seen in Figures 19 and 20, as well as in Table 7, that the illuminance gradient in the test model with the light pipe (with both diffusers) is lower than that of the reference case. The illuminance contrast gradient (ICG) gives an idea of the uniformity of the lighting distribution, and it is defined as the ratio of the averaged values of the half-front of the room by the averaged values of the half-back of the room. Table 7 shows the ICG at 9am and at 12pm, making evident the better performance of the light pipe system over the reference case regarding light distribution. This reduction in the contrast between areas of the same space indicates a better quality and uniformity of the lighting levels across the space.

Table 7

Average illuminance at the half-front (max.) and half-back of the space (min.) and the resulting illuminance contrast gradient (ICG) for two light pipe conditions compared to the reference case

Date	Conditions in models	9:00 AM			12:00 PM		
		AVG Front	AVG Back	ICG	AVG Front	AVG Back	ICG
04/02/05	Reference model	297	92	3.2	549	168	3.3
	Light pipe with Mylar	321	230	1.4	610	644	0.9
03/12/05	Reference model	432	133	3.2	750	229	3.3
	Light pipe with Barrisol	480	212	2.3	871	604	1.4

The difference of the daylighting quality can be visualized in Figure 21 where the outside receptor of the light pipe was covered with a black cloth and then uncovered. Hence, the effect due to the window contribution is compared visually to the window with closed blinds plus the light pipe with Mylar® contribution. The uniformity of the daylight distribution due to the light pipe is easily appreciated in Figure 21c as opposed to Figure 21a, which has a dark back. It is also depicted by luminance false color image 21b. The light delivered by the light pipe illuminates the workplane and side walls on the half-back as well as the back wall. It also helps to make an overall clearer ceiling, which helps it to feel lighter than in picture 21a. The illuminance values at the back at the time Figure 21c was taken ranged from 500 lux on the sides to 1000 lux on the center-back.

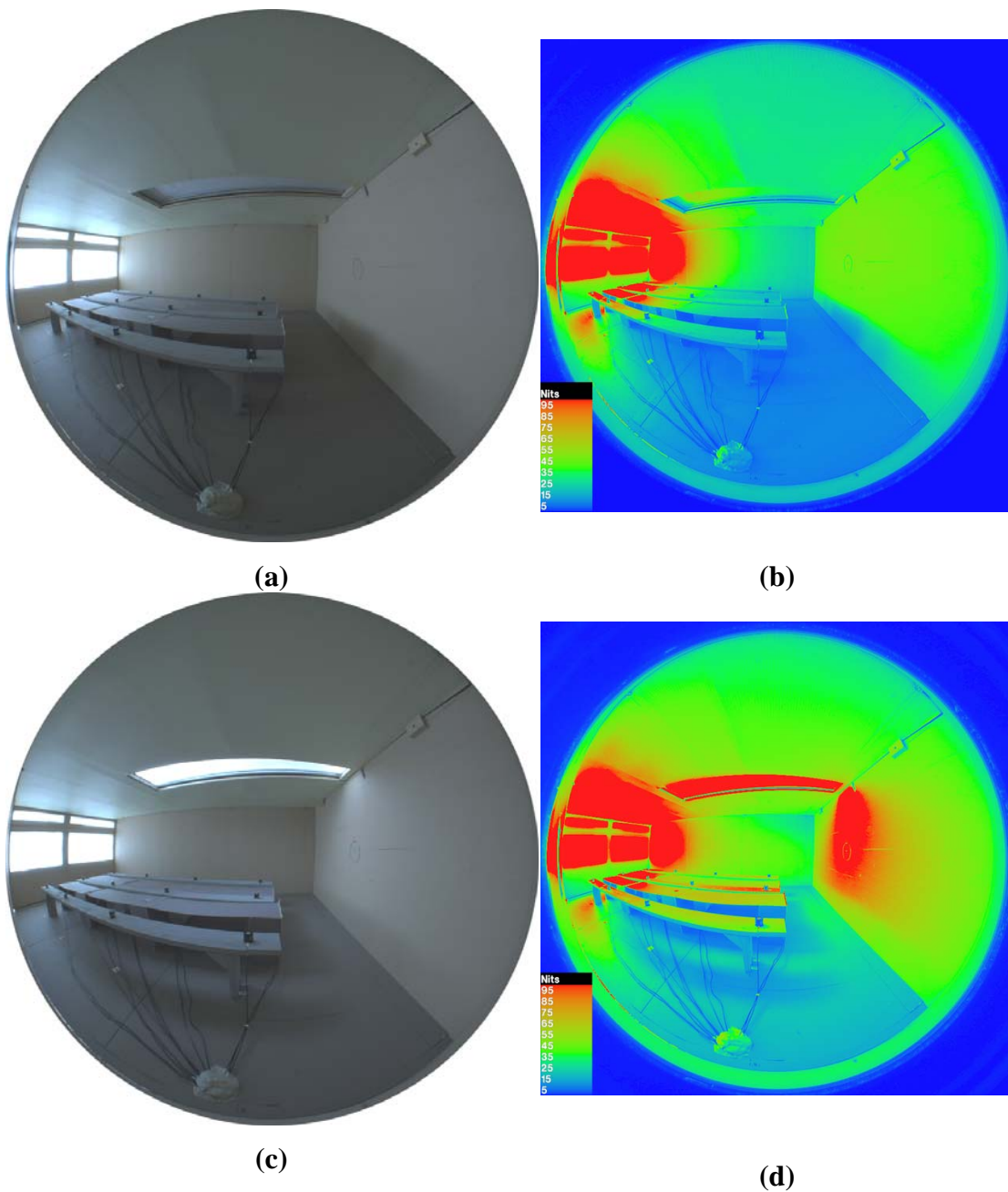


Fig. 21. Two consecutive HDR images on March 1<sup>st</sup> at 1pm. (a) The light pipe collector has been covered, and the only light entering the model is through the window. (c) The light pipe is channeling the daylight to the back of the room. False color images of luminance values (b) and (d) were generated with Winimage (Desktop RADIANCE) from each HDR image.



The improvement introduced by the light pipe system at the back of the room helps to obtain more uniform light levels, as Figure 22 indicates.

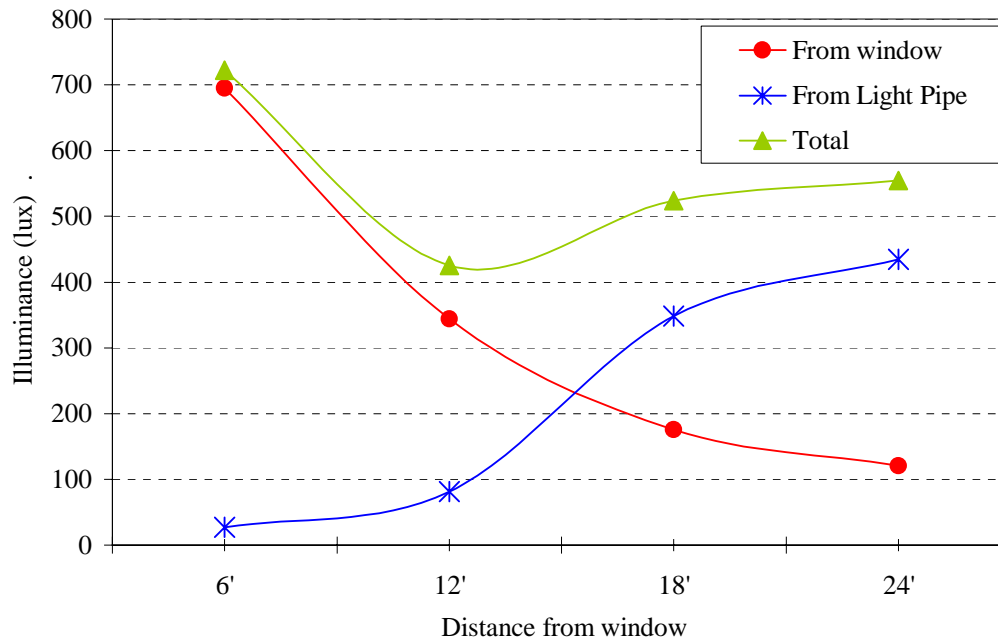


Fig. 22. Workplane illuminance (h: 28") longitudinally along the middle of the space, due to daylight contribution from window with closed blinds and from light pipe with Mylar, and the total combination of both contributions. April 1<sup>st</sup>, 10am. Exterior horizontal illuminance 95,039 lux.

As the comparison with the reference case gives a better idea of the improvements provided by the light pipe system, Figures 23 and 24 show the illuminance values at the workplane longitudinally along the middle of the room for both cases, considering two light pipe conditions, with Mylar® and with Barrisol®. In all cases for the last two points in the back, the improvement due to the light pipe system is indicated as a percentage over the values obtained in the reference room. For both conditions at all times, the light pipe introduces daylight at the rear of the room, increasing the illuminance levels that otherwise would have been low enough to need electric light to reach the required light levels.

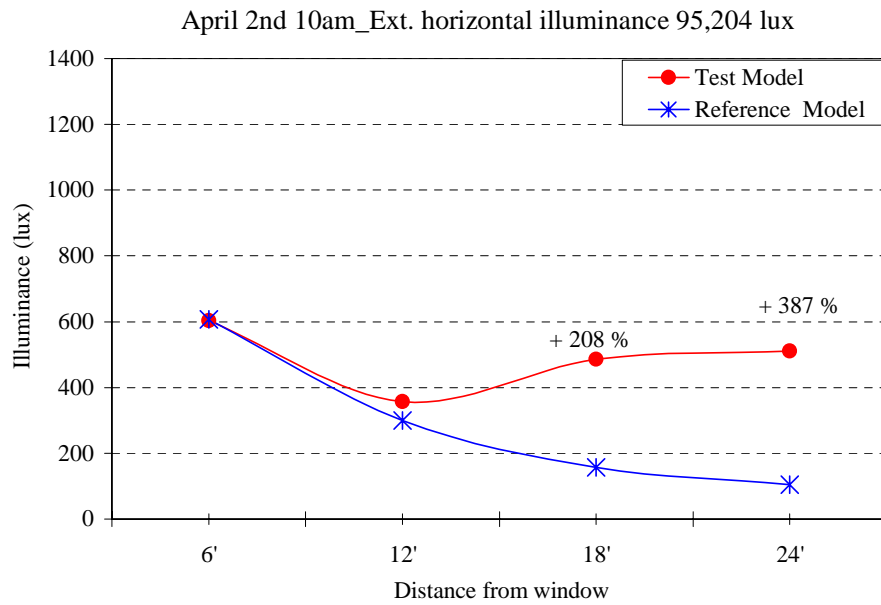
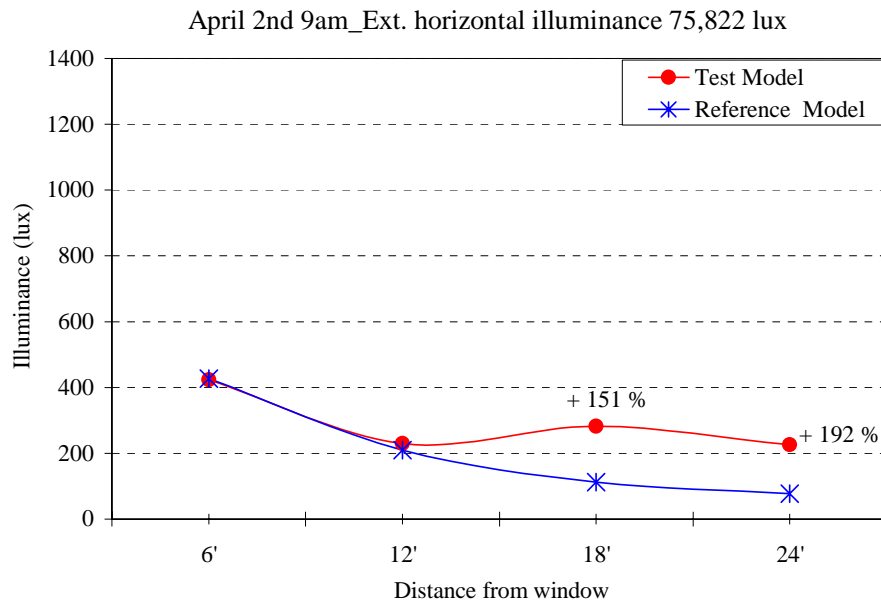


Fig. 23. Workplane illuminance (h: 28") longitudinally along the middle of the space, due to light pipe with Mylar® and window with closed blinds in test model, and window with closed blinds in reference model. April 2<sup>nd</sup> from 9am to 12pm.

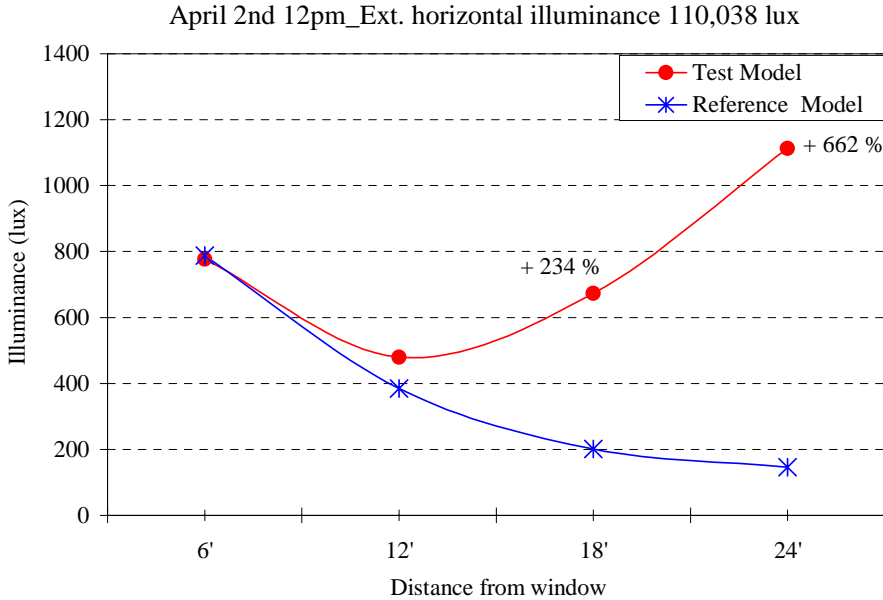
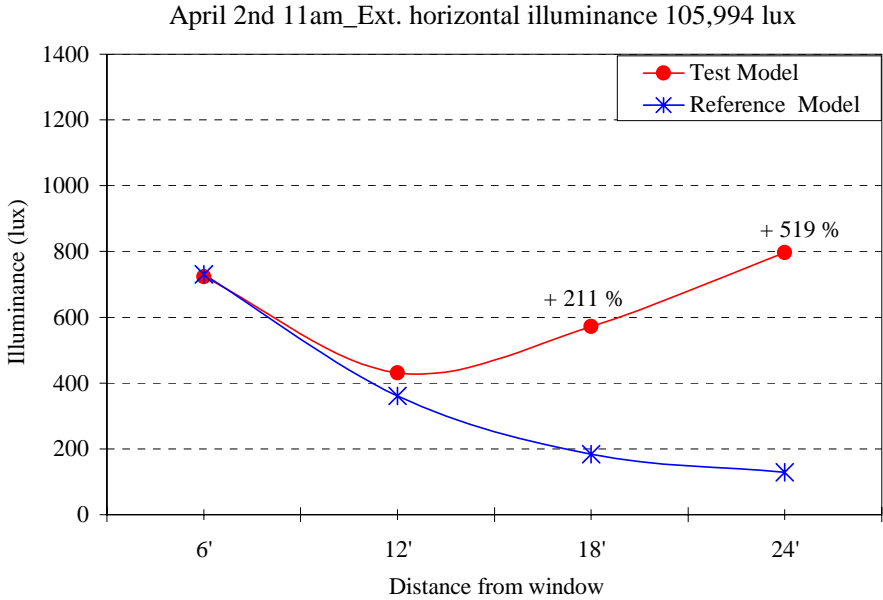


Fig. 23. Continued.

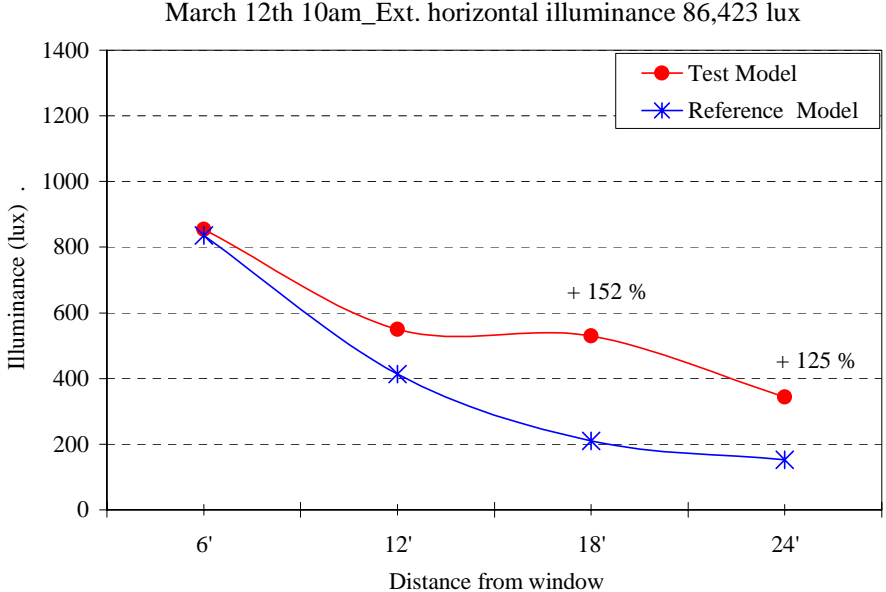
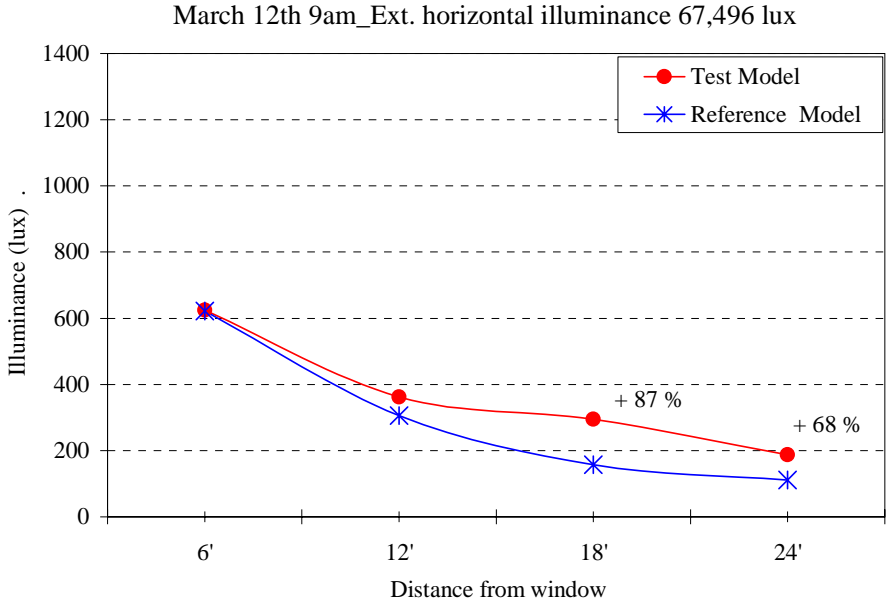


Fig. 24. Workplane illuminance (h: 28") longitudinally along the middle of the space, due to light pipe with Barrisol® and window with closed blinds in test model, and window with closed blinds in reference model. March 12<sup>th</sup> from 9am to 12pm.

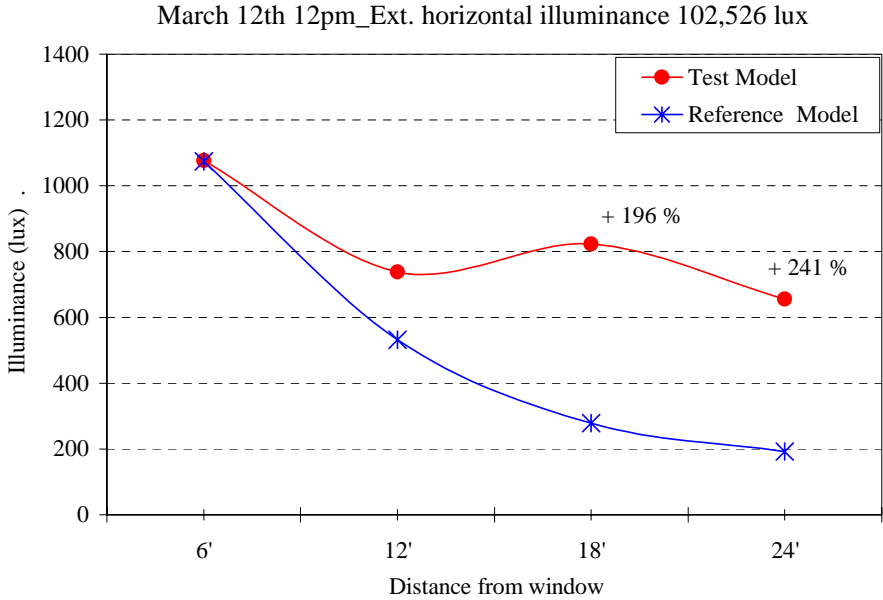
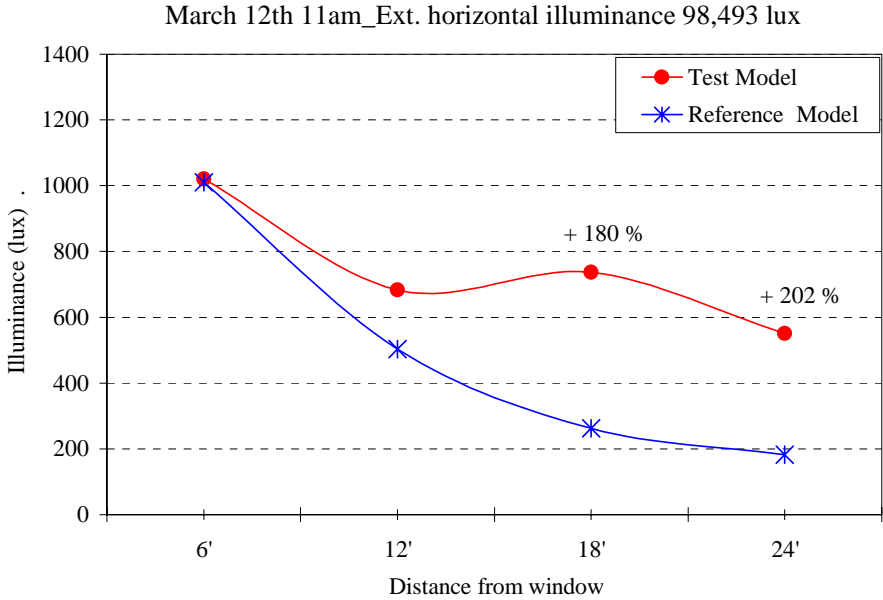


Fig. 24. Continued.

It can be appreciated, in both conditions, that the light pipe curve tends to flatten within the last three points (excepting light pipe with Mylar® at 11 am and noon), indicating a better uniformity on the lighting conditions in that area. The illuminance values next to the window could be much lower, giving a flatter line, if an exterior shading device such as louvers or overhangs was introduced at the façade plane. Overall, the light pipe with Mylar® delivers more daylight than the light pipe with Barrisol®, which is directly related to the transmissive properties of each material. Consequently, the daylight levels reached with each material could be taken into consideration during the design stage, depending on the type of work that is going to be developed in the office space.

The contribution by itself of each light pipe condition was analyzed. Figures 25 to 27 show a 3D distribution of daylight in the rear of the office space at 9am and 3pm (3pm values are very similar to those at 9am), and at 12pm, due to the light pipe contribution for each condition without the lower window. At 9am and 3pm, values for all the conditions are a little higher at 18 ft than at 24 ft due to oblique angles having the output at approximately that distance. At 12pm, the biggest concentration of daylight is at 24 ft on the center, except for the Barrisol® diffuser example that is at 18 ft. This difference is due to the time of the year the illuminance levels were measured for the different light pipe conditions. When the Barrisol® contribution was evaluated on March 11<sup>th</sup>, the central collector design for the equinoxes makes the sunbeam bounce differently than the collector for the winter solstice would do, hence making the output closer to the 18 ft row than to the 24 ft row (which is the case of the other two examples: “raw” and Mylar®). Nevertheless, noon is the peak on the daylight output throughout the day for all the light pipe conditions, since the central reflectors were designed for solar noon. At this time the azimuth of the sun is 0°; thus the sunbeams are entering directly towards the output. The raw light pipe condition concentrates the daylight even more on the center part precisely because it does not have a diffuser, which would help to redistribute the light evenly. For that reason, it is also the condition with greater and more variable contrast gradient, as Table 8 indicates.

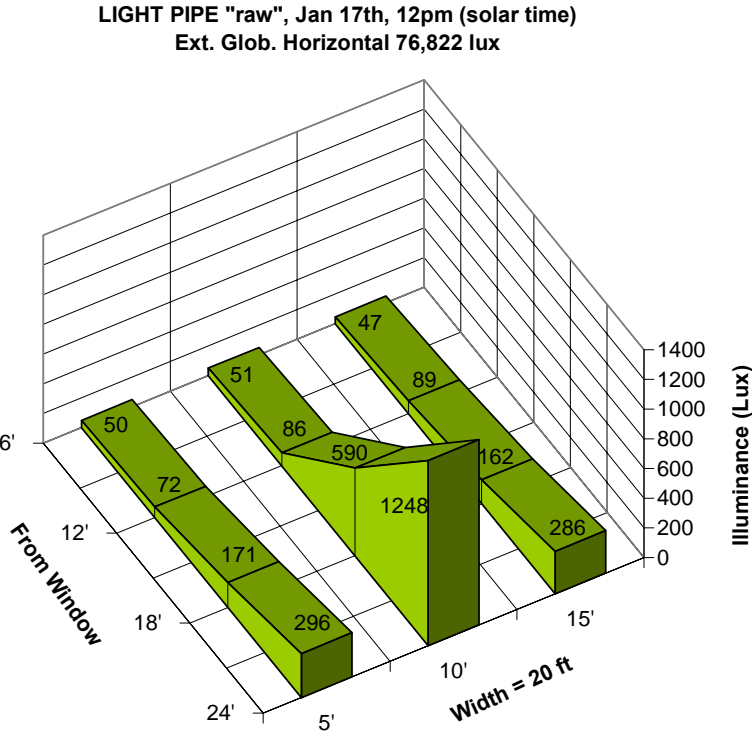
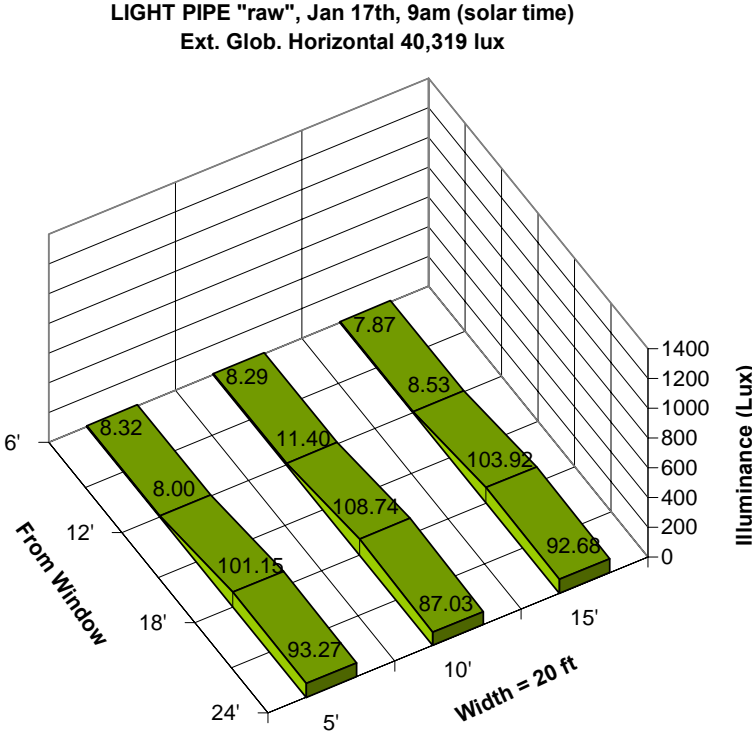


Fig. 25. Workplane illuminance (lux) due to raw light pipe without window contribution. Measured at College Station, TX, showing sun and sky contribution on a clear day at 9am and 12pm (solar time).

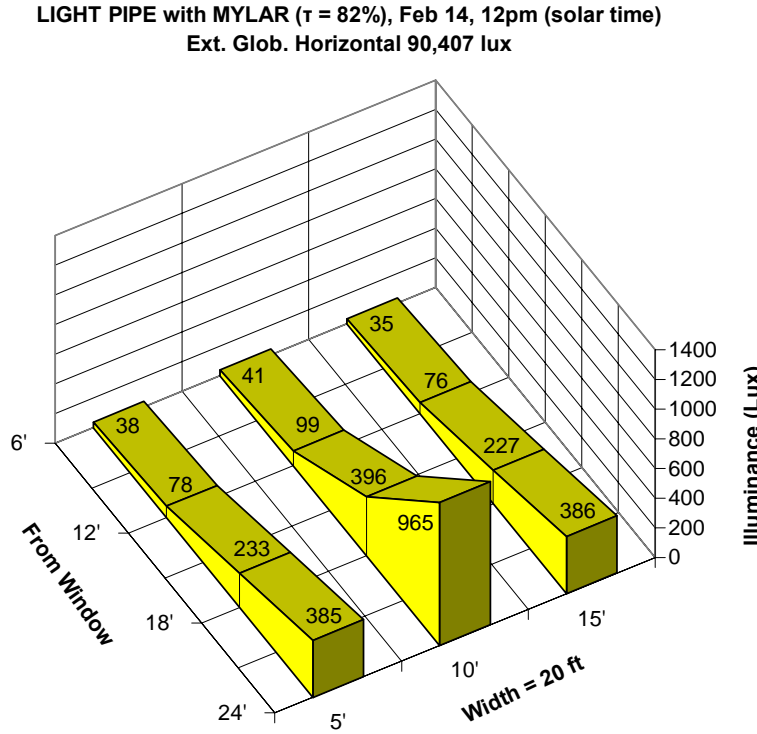
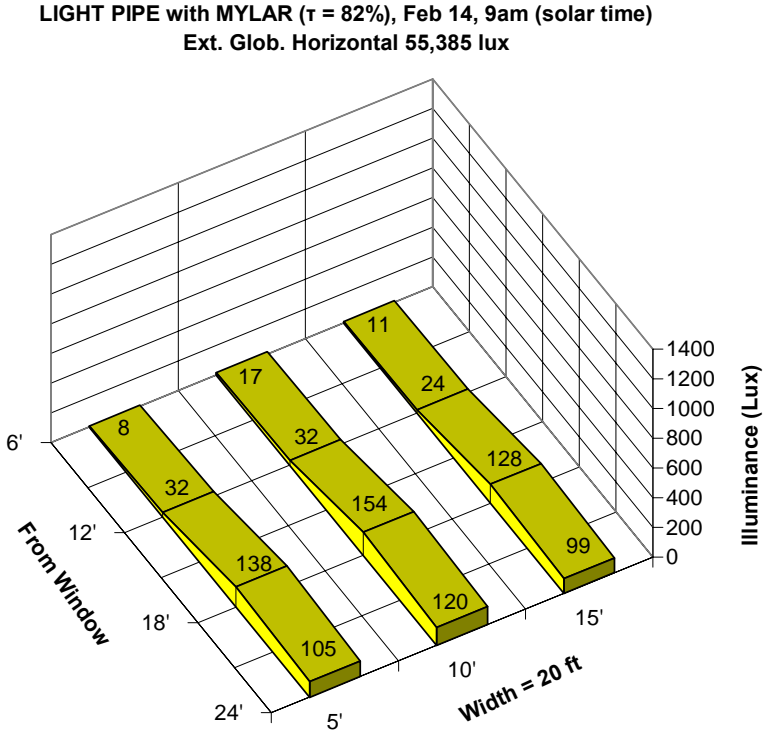
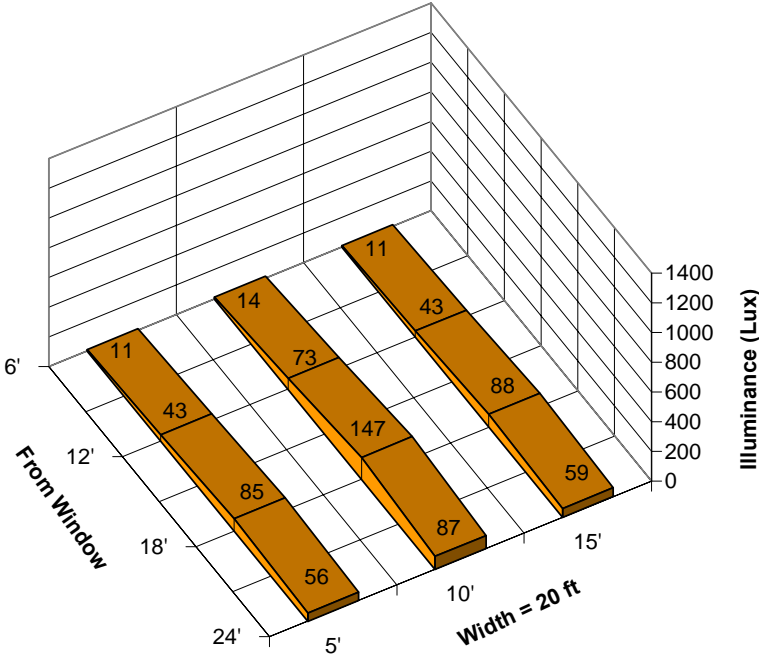


Fig. 26. Workplane illuminance (lux) due to light pipe with Mylar®, without window contribution. Measured at College Station, TX, showing sun and sky contribution on a clear day at 9am and 12pm (solar time).



**LIGHT PIPE with BARRISOL ( $\tau = 56\%$ ), Mar 11, 9am (solar time)  
Ext. Glob. Horizontal 66,917 lux**



**LIGHT PIPE with BARRISOL ( $\tau = 56\%$ ), Mar 11, 12pm (solar time)  
Ext. Glob. Horizontal 101,360 lux**

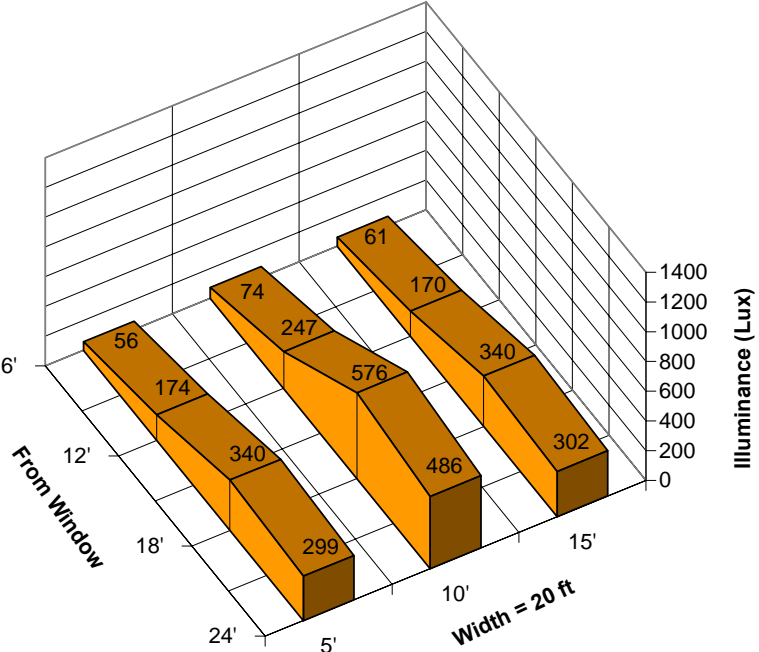


Fig. 27. Workplane illuminance (lux) due to light pipe with Barrisol®, without window contribution. Measured at College Station, TX, showing sun and sky contribution on a clear day at 9am and 12pm (solar time).

Table 8  
 Maximum and minimum workplane illuminance (lux) and illuminance contrast gradient (ICG) across the 15-30 ft area for the three light pipe conditions without lower window. Measurements taken from December to March.  
 ICG=Max./Min. workplane illuminance for 6 sensors at the back

Light Pipe condition	December						January						February						March					
	9:00 AM		12:00 PM		9:00 AM		12:00 PM		9:00 AM		12:00 PM		9:00 AM		12:00 PM		9:00 AM		12:00 PM		9:00 AM		12:00 PM	
	max	min	CG	max	min	CG	max	min	CG	max	min	CG	max	min	CG	max	min	CG	max	min	CG	max	min	CG
Raw Light Pipe	129	25	5.2	3885	132	29.4	130	93	1.4	1248	162	7.7	115	78	1.5	686	127	5.4	138	102	1.4	795	194	4.1
Light pipe with Mylar	N/A	N/A	N/A	N/A	N/A	N/A	195	100	2.0	1083	215	5.0	163	133	1.2	965	227	4.3	170	121	1.4	949	259	3.7
Light pipe with Barrisol	N/A	N/A	N/A	N/A	N/A	N/A	151	34	4.4	343	181	1.9	N/A	N/A	N/A	N/A	N/A	N/A	147	56	2.6	576	299	1.9

Table 9  
 Maximum and minimum workplane illuminance (lux) and illuminance contrast gradient (ICG) across the 15-30 ft area for the three light pipe conditions with lower window contribution. Measurements taken in January and March.  
 ICG=Max./Min. workplane illuminance for 6 sensors at the back

Light Pipe condition with window contribution	January						March					
	9:00 AM		12:00 PM		9:00 AM		12:00 PM		9:00 AM		12:00 PM	
	max	min	CG	max	min	CG	max	min	CG	max	min	CG
Raw Light Pipe+window	446	254	1.8	1526	554	2.8	N/A	N/A	N/A	N/A	N/A	N/A
Light pipe with Mylar+window	453	288	1.6	1390	630	2.2	282	186	1.5	1113	462	2.4
Light pipe with Barrisol+window	431	232	1.9	698	450	1.6	295	156	1.9	824	470	1.8

As seen in Table 8, the biggest contrast gradient for the raw light pipe as well as for the light pipe with Mylar® occurs at noon, contrary to the light pipe with Barrisol®, which happens at 9am. From Table 9 can be deduced that, when the contribution of the window is added, it helps to decrease the contrast as much as 50% of the previous value shown in Table 8. With the contribution of the window, the diffuser Barrisol® keeps a more stable behavior throughout the working hours regarding distribution of light in the back area of the room than the other two conditions (Mylar® and raw light pipe). It also achieves levels of light closer to those recommended for an office with VDT screens (IESNA Lighting Handbook, 2003), compared to the diffuser Mylar®.

#### **4.2. RAYTRACING WITH TIME-LAPSE IMAGES**

The purpose of the light pipe without a diffuser on the emitter section is to analyze the maximum potential of this advanced daylighting system and to study the patterns and effects of the concentrated sun beam inside the test model.

On March 8<sup>th</sup>, a sequence of photos with a set interval of 10 minutes was taken to follow the patterns cast by the raw light pipe on the side and back walls of the test model and over the workplane. A selection of the time-lapse images is displayed in Figure 28 where it can be noticed that early in the morning half of the side walls, as well as the sensors at 18 ft and at 24 ft, are well-illuminated. As noon approaches, the light starts to concentrate directly below the light pipe, and the sun patch gets brighter on the back wall and recedes from the side walls. Consequently, the sensors at 24 ft get more light as opposed to the sensors at 18 ft that enter in a penumbra. At noon, the sun patch is at the center of the back wall; hence, the light reflected from it reaches the sensors in the middle row, especially the one at 24 ft.

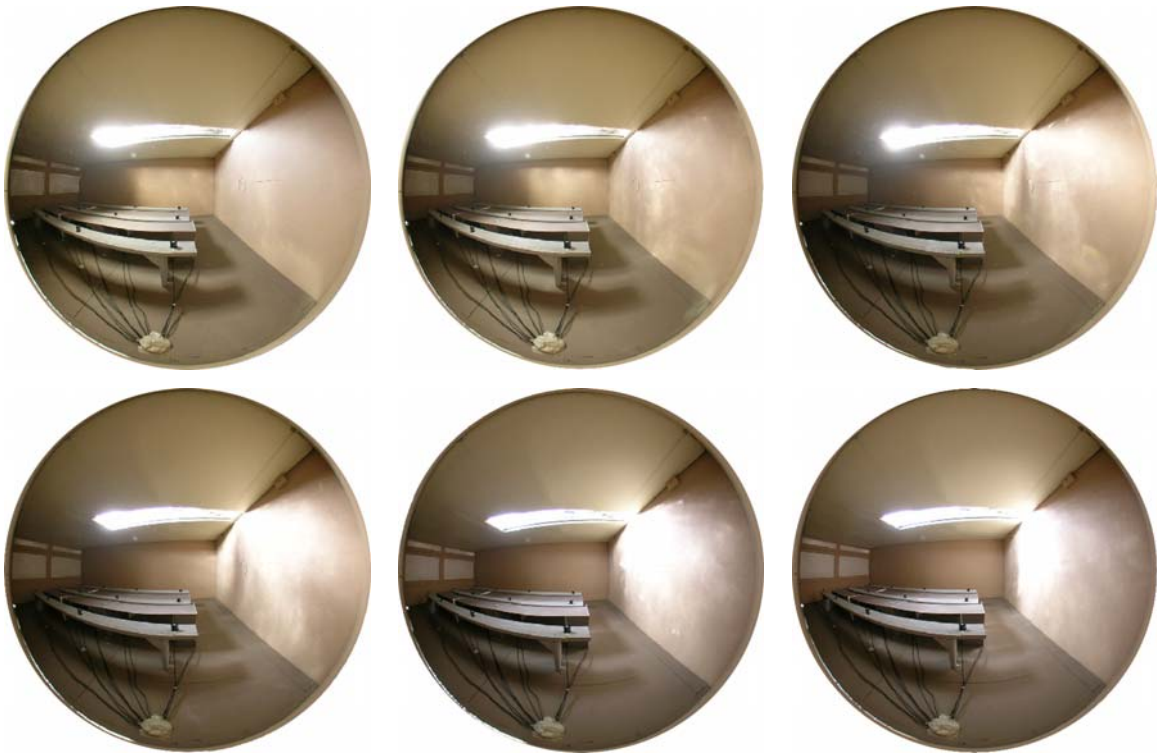


Fig. 28. Time-lapse images from 9:30am to 12pm, showing the raw light pipe output casting changing patterns on side and back walls.

#### 4.3. MEASUREMENTS UNDER OVERCAST SKY CONDITIONS

Although the light pipe is not intended for overcast sky conditions, data was analyzed to study its performance, and some findings emerged. The light pipe with the Mylar® diffuser was the condition considered since this material is more transmissive than the other diffuser used (Barrisol®). The values measured at the center lane of sensors (lengthwise) were taken to observe the light pipe contribution and the window contribution in two different states, with semi-opened and with closed blinds. Figures 29 and 30 show these values and the combination of their contributions. The light pipe helps to introduce 165 lux at 24 ft, which shows to be helpful in combination with the window with semi-opened blinds, reaching slightly more than 300 lux. However, its contribution is not enough when blinds are closed on an overcast day, since the combination of window and light pipe reaches a maximum of 217 lux at 24 ft.

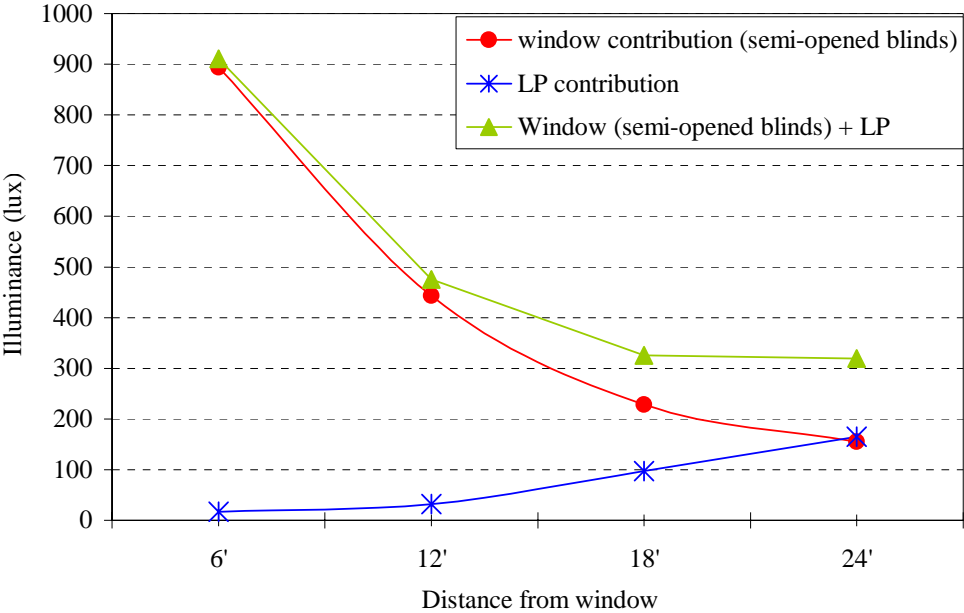


Fig. 29. Workplane illuminance (h: 28") from window with semi-opened blinds and light pipe with Mylar® under overcast conditions. February 20<sup>th</sup>, 12pm. Ext. horizontal illuminance 48,200 lux.

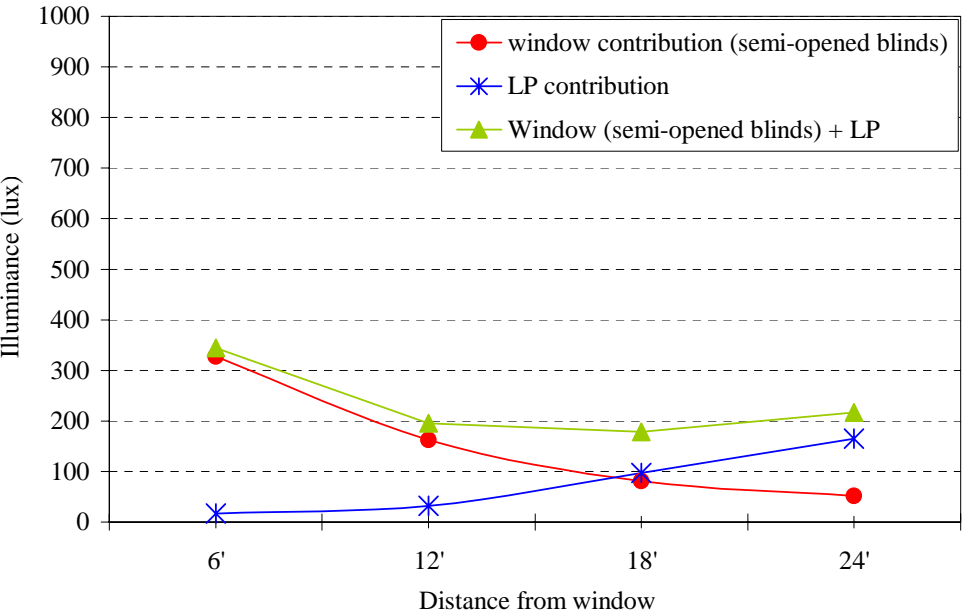


Fig. 30. Workplane illuminance (h: 28") from window with closed blinds and light pipe with Mylar® under overcast conditions. March 2<sup>nd</sup>, 12pm. Ext. horizontal illuminance 44,911 lux.

Figure 31 shows the spatial distribution on an overcast day of illuminance levels of the reference model and the test model, both with semi-opened blinds. Compared to the reference test, the test model gives higher lighting levels at the rear of the space due to the light pipe contribution. However, daylight factors in Figure 32 indicate that the room needs electric light since a daylight factor below 2% indicates a gloomy space.

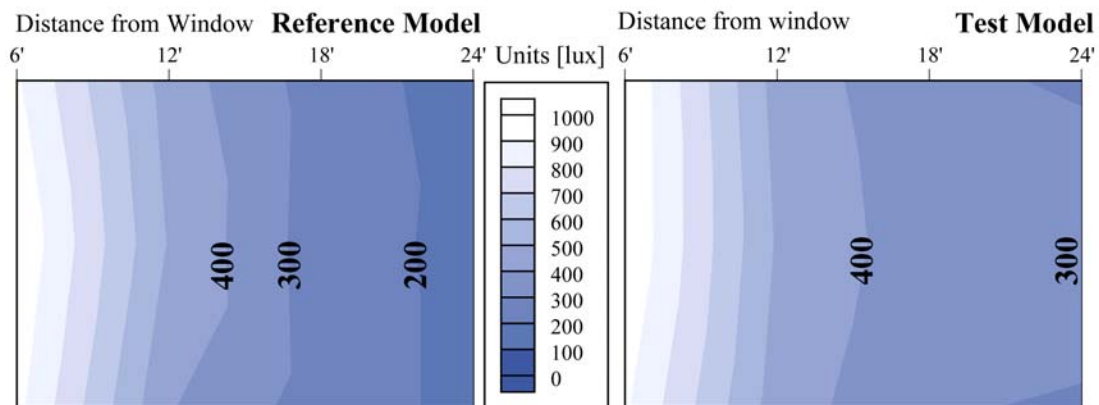


Fig. 31. Workplane illuminance (h: 28") in reference model and in test model with light pipe with Mylar® with semi-opened blinds in both models under overcast conditions. Feb 9<sup>th</sup>, 12pm. Ext. horiz. illuminance 41,898 lux.

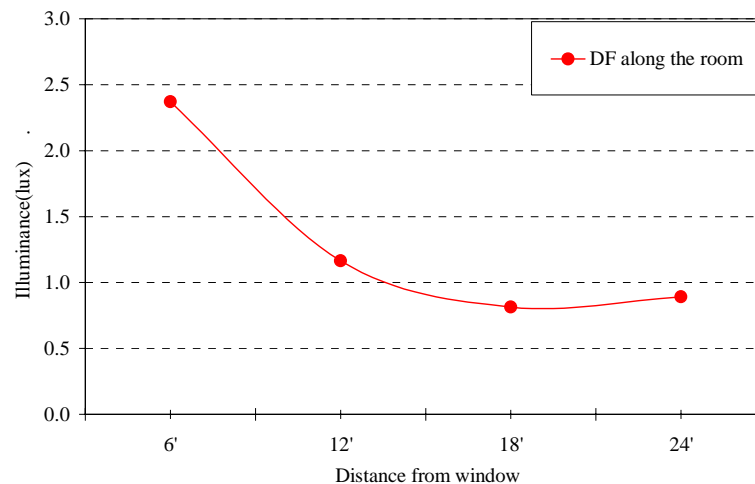


Fig. 32. Daylight factor on the workplane (h: 28") at the center of the space in the test model due to light pipe with Mylar® and window with semi-opened blinds. Overcast conditions, Feb 9<sup>th</sup>, 12pm. Ext. horizontal illuminance 41,898 lux.

#### 4.4. ANALYSIS OF VISUAL COMFORT AND GLARE ANALYSIS

##### 4.4.1. Photographic Documentation with HDR Images and Luminance Ratios

The light pipe system with Mylar® diffuser was photographed on March 1<sup>st</sup> at 1pm, and simultaneous luminance measurements were taken at four points. The values measured are in Figure 33. ISO-contours generated from the HDR image depict a luminance map throughout the entire space (Figure 34).

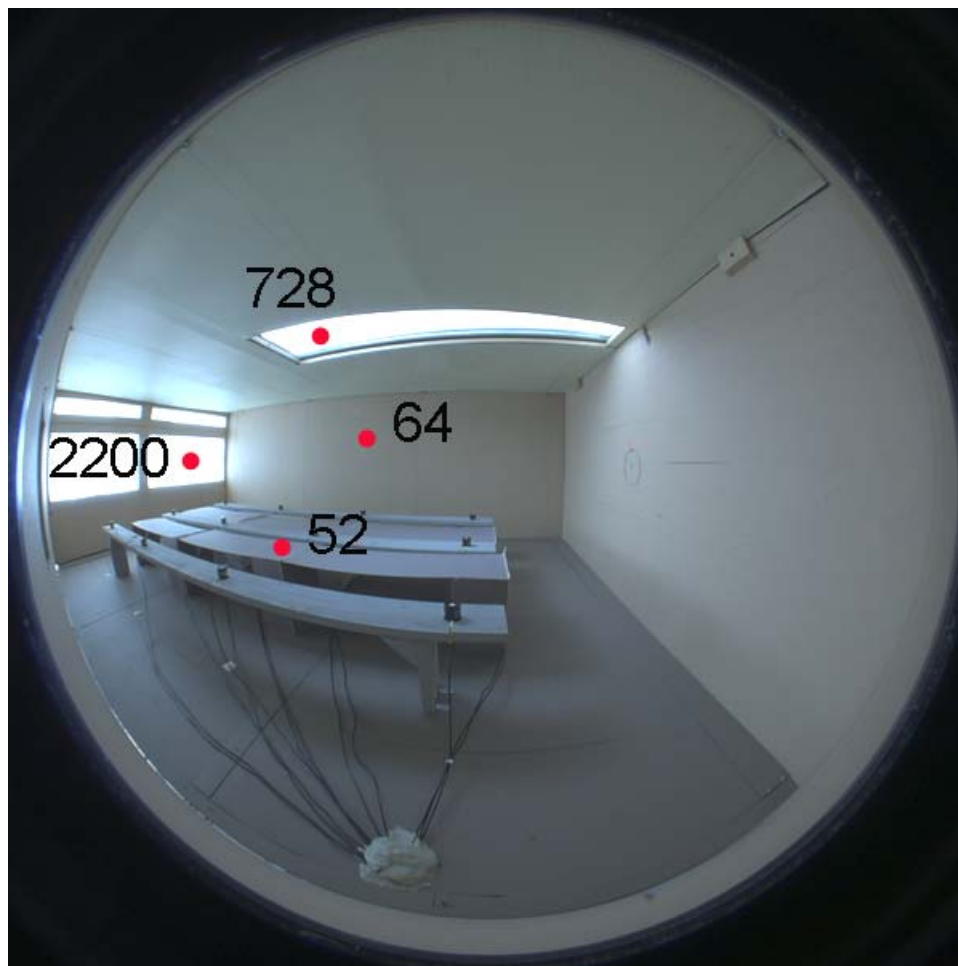


Fig. 33. HDR image of light pipe with Mylar® on March 1<sup>st</sup> at 1pm with spot luminance measurements of four reference points.

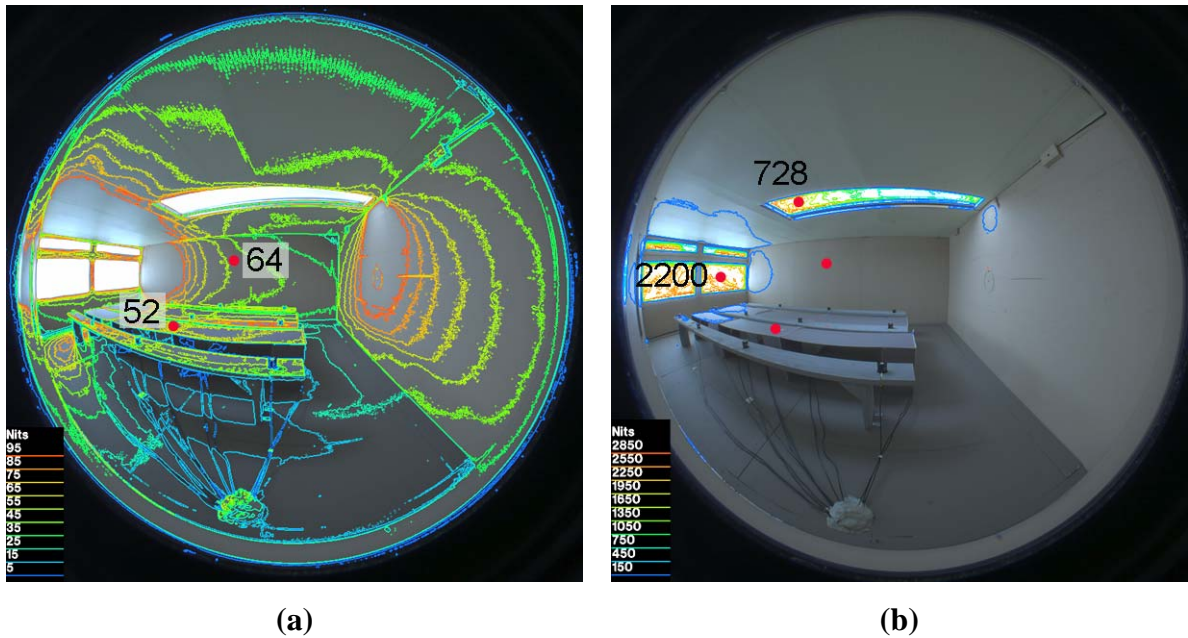


Fig. 34. Iso-contours generated with Desktop Radiance of (a) low luminance values, (b) high luminance values. Picture taken on March 1<sup>st</sup> at 1pm.

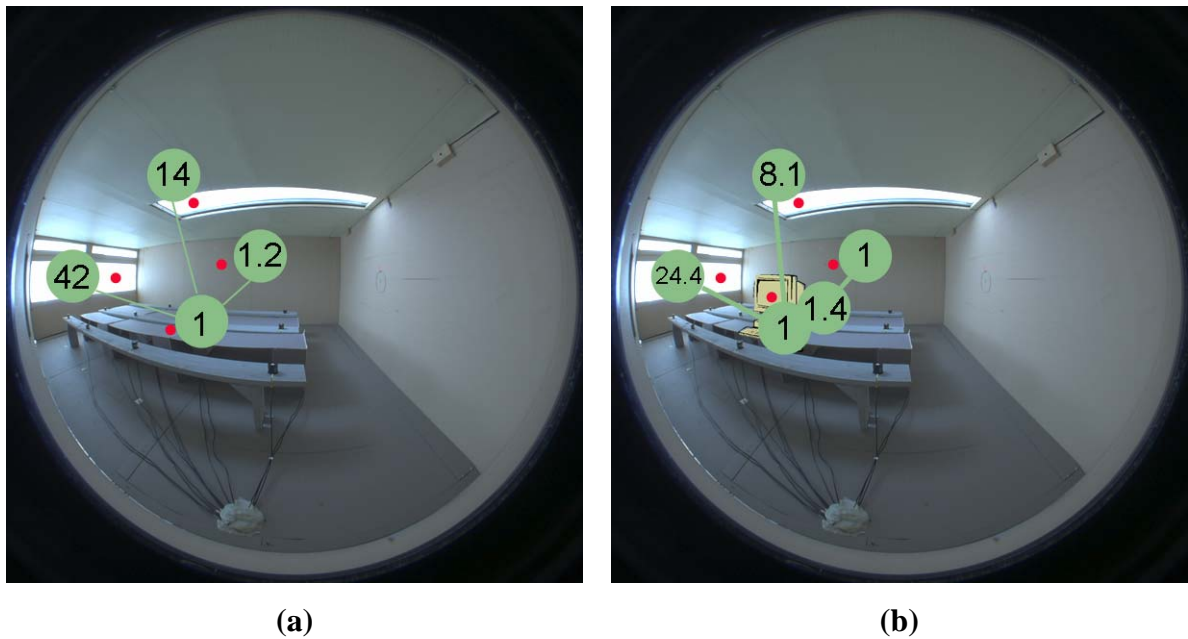


Fig. 35. Luminance ratios between (a) the point at the desk and the three other reference points, (b) the VDT screen, with a luminance value of 90 cd/m<sup>2</sup>, and the three other reference points. Picture taken on March 1<sup>st</sup> at 1pm.



As seen in Figure 35a, the ratio between the desk and the wall in front is within the recommended standards, but the other two ratios are not. The ratio between the desk and the window with simulated closed blinds could be lower if a shading device was placed outside on the façade. Regarding the ratio of the light pipe and the desk, one restriction should be noticed. The point on the desk is not indicative enough. A fairer situation would have had a VDT screen on the desk, although its materialization is a constraint due to the scale on the model. To solve this difficulty, luminance of a VDT screen with negative contrast (black characters on a white background) with a usual value of 90 cd/m<sup>2</sup> was taken (ANSI/IESNA RP-1-04, 2004). In that way, the ratio between the VDT and the point on the light pipe output gives 8.1, which is less than the maximum recommendation of 1 to 10. According to IESNA Lighting Handbook, pp.11-17, “The maximum ceiling luminance should not exceed ten times that of the VDT screen if the luminance ratio standards are to be maintained.” A new set of contrast ratios, now related to the VDT screen, shows better visual conditions, as in Figure 35b.

The light pipe placed overhead, as it is the test model case, is not likely to cause either direct or reflected glare. However, direct glare must be evaluated in case this design goes into a real open-plan office. Light pipe outputs placed further from the person, within 45° and 85°, may fall into his field of view, causing glare problems (Reynolds, 2000), as can be observed in Figure 36. The use of partitions has to be considered, as it may reduce the offending area that could cause direct glare. Reflected glare may occur, but it can be easily avoided by using flat monitors with matte finish, or VDTs with adjustable tilting swivel. Figure 37 shows the offending zone that is dependent on the eye-screen geometry (ANSI/IESNA RP-1-04, 2004). Further exploration is needed regarding glare evaluation (glare assessment was also evaluated with the survey; for more information see page 66).

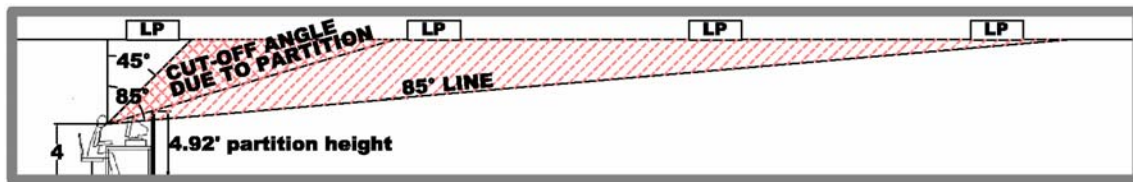


Fig. 36. Arrangement of light pipes in an open-plan office to evaluate direct glare depending on contrast ratio between VDT screen and light pipe luminance values. Offending zone (direct glare possibility) from 45° to 85°.

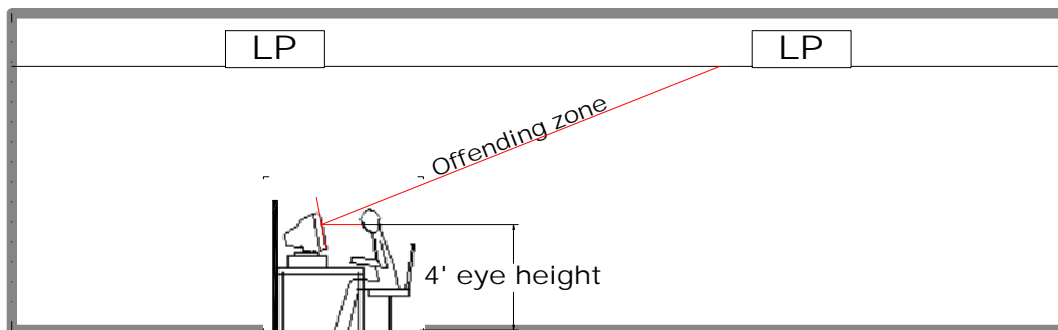


Fig. 37. Reflected glare on VDT monitor.

#### 4.4.2. Analysis of Survey for Human Response Evaluation

The survey conducted on February 3<sup>rd</sup> and 4<sup>th</sup> had the purpose of evaluating people's responses when comparing a typical sidelight office space (model #1) to a space with the same characteristics but equipped with the light pipe system (model #2). Nineteen people were interviewed, six on the first day and thirteen on the second day. Most of them were graduate students who work in some type of office configuration, either with or without daylight (Tables 10 and 11).

Table 10  
Information of people who attended the survey on 02/03/2005 and 02/04/2005

Personal Info	Characteristics	Percentage	Quantity
<b>Gender</b>	Female	63%	12
	Male	37%	7
<b>Age Group</b>	19-24	21%	4
	25-34	53%	10
	35-44	16%	3
	45-54	11%	2
<b>Level of Education completed</b>	Bach	68%	13
	Master	16%	3
	PhD	16%	3
<b>Occupation</b>	Student	79%	15
	Faculty	5%	1
	Staff	5%	1
	Other	11%	2

Table 11  
Working environment and lighting preferences of people who attended the survey

Personal Info	Characteristics	Percentage	Quantity
<b>work environment</b>	classroom	5%	1
	computer lab	16%	3
	enclosed private office	37%	7
	enclosed office shared with others	26%	5
	workstation with partitions	none	0
	office without partitions	none	0
	other	16%	3
<b>DL availability at workspace</b>	DL yes	63%	12
	DL no	37%	7
<b>Lighting preferences</b>	like DL only	32%	6
	like EL only	none	0
	combination DL + EL	68%	13

Figure 38 shows the different sky conditions on both days during the survey. On February 3<sup>rd</sup> it was partly cloudy from 11:40am to 3:20pm, and on February 4<sup>th</sup> it was sunny but hazy until noon, and then it turned cloudier.

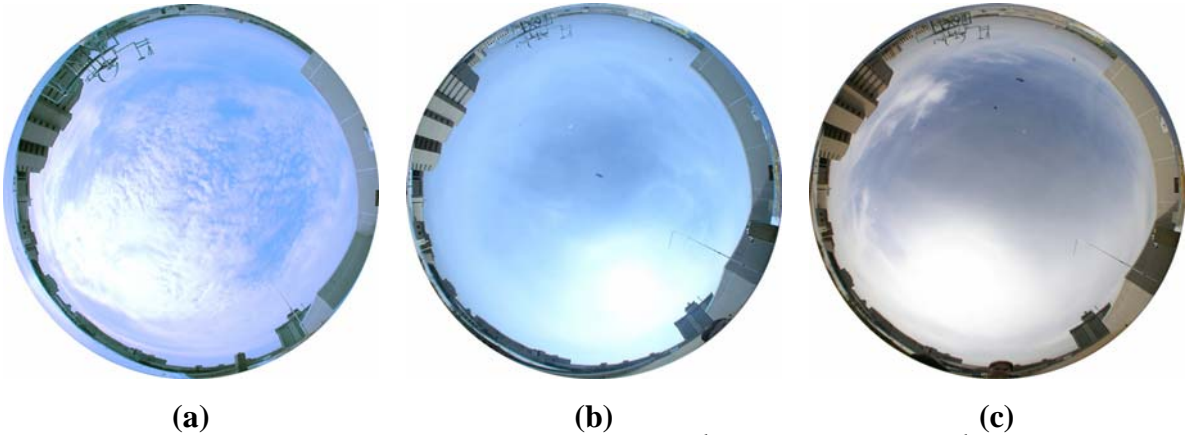


Fig. 38. Different sky conditions during the survey. (a) On Feb 3<sup>rd</sup> afternoon, (b) on Feb 4<sup>th</sup> morning, and (c) on Feb 4<sup>th</sup> afternoon.

The first impression about the overall lighting conditions was 95% satisfactory for the space with the light pipe, while for the reference space 58% of the respondents agreed that it was too dim (Figure 39).

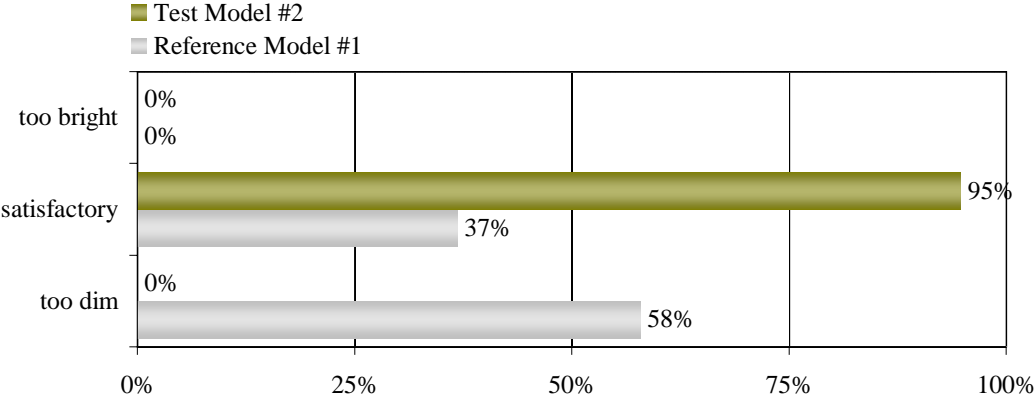


Fig. 39. Question #8: What is your impression, at first glance, of the overall lighting conditions?

Regarding the probability of turning on the electric light in each space, 95% (18) of the people answered they would do it in model #1, mostly at the back of the space;

and only 21% (4) said they would need it in model #2, three of them at the back of the space (Figure 40).

The preferred place to sit in model #1 was next to the window for eighteen of the respondents; most of them explained that it was because “the back was too dark,” or because they wanted “more natural light.” In model #2, nine did not have a preference since “the room looked equally bright,” or there was a “satisfactory light level in the whole room,” or because “the light is distributed evenly;” four chose the back because they “prefer diffused natural light” or “there is too much glare at front and [they] feel more relaxed when light comes from the ceiling,” or “the light is just right;” and five still preferred the window because they wanted to have a “view to the outside,” or they wanted “more natural light” (Figure 41).

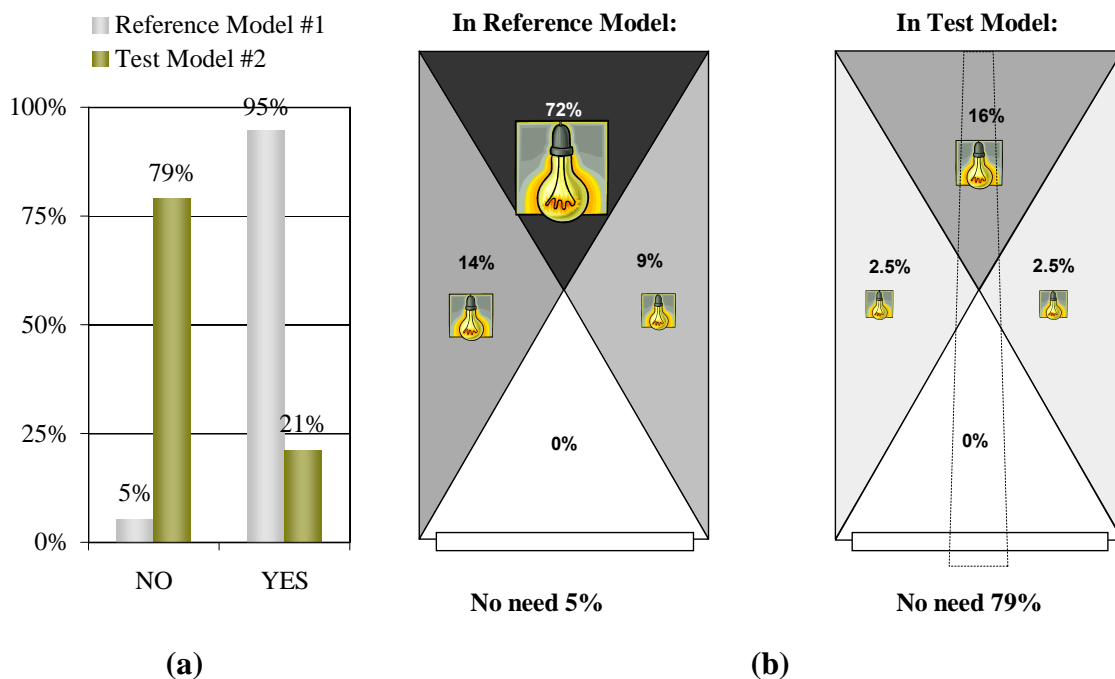


Fig. 40. Probability of turning on the electric light. (a) Question #10: Do you think you would need to turn ON the electric light in model #1? And in model #2? (b) Question #11: If yes, where?

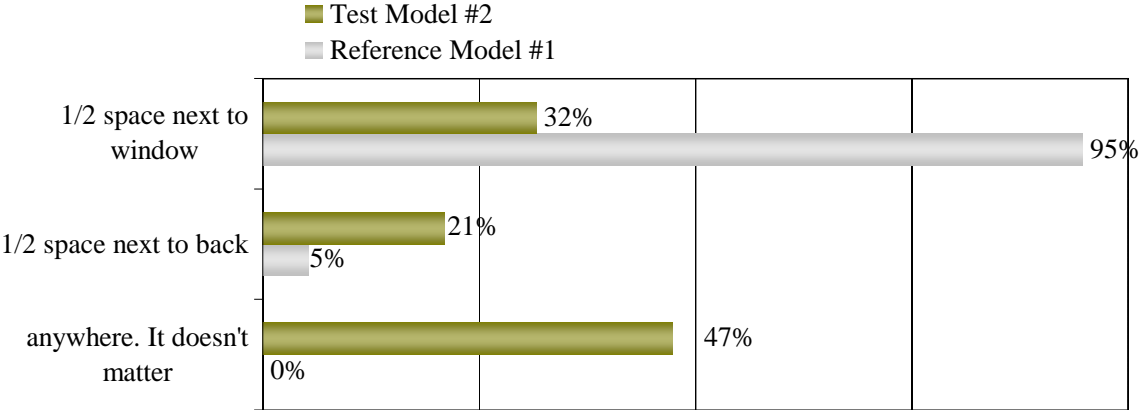


Fig. 41. Question #12: In which part of the space would you prefer to sit if you were working in model #1? And in model #2?

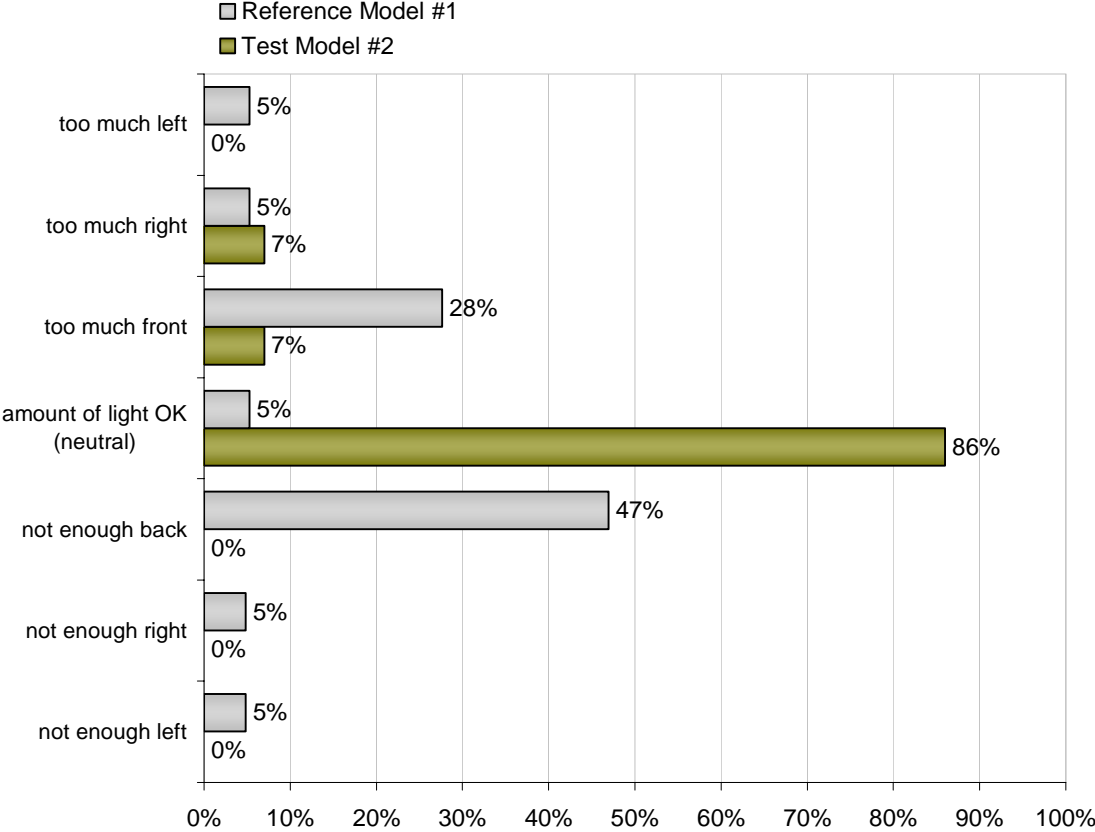


Fig. 42. Question #14: Is there too much light in some areas and not enough in others? Where?

When asked if there was enough light in each space, 86% answered that the light in model #2 was satisfactory while 47% said that the light was not enough at the back of model #1 (Figure 42). A considerable amount of people responded that it was excessive light at the front in model #2. This could be because of two reasons: one could have been the contrast with the dark back, or it could have been because the windows were simulating semi-opened blinds at the time of the survey; then too much light may have been entering through them, regardless of the cloudy conditions. This explanation may also be valid to the answers about glare problems shown in Figure 43, where 26% of the respondents in model #1 and 16% in model #2 said that there was glare at the window. On the other hand, no one found glare at the light pipe output, even though such output falls within the direct glare zone, as is illustrated in Figure 44. On the other hand, light pipe performance due to existing sky conditions at the time of the survey must be taken in consideration for a complete validation of glare probability with this advanced daylighting system.

As an indicator, thirteen of the participants considered themselves to be sensitive to glare, and ten used some kind of glasses (seven of the ten used sunglasses), these results can be seen in Figure 45.

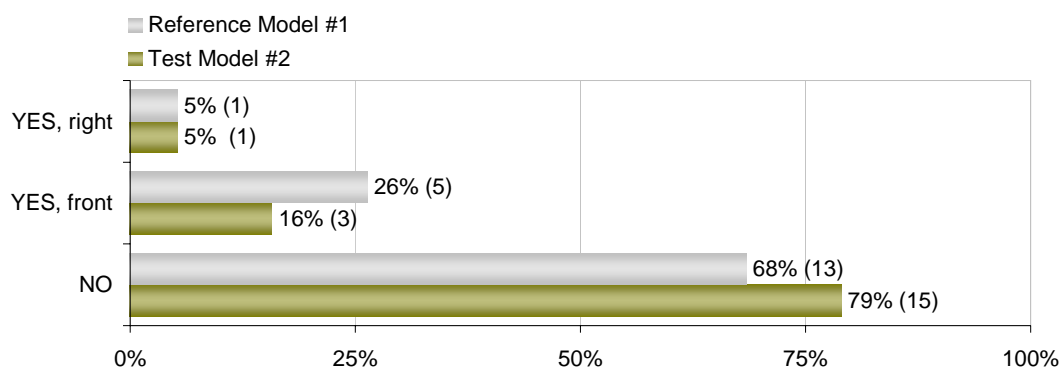


Fig. 43. Question #15: Do you think that there are enough glare problems in model #1 to bother you? And in model #2? If yes, please say where.

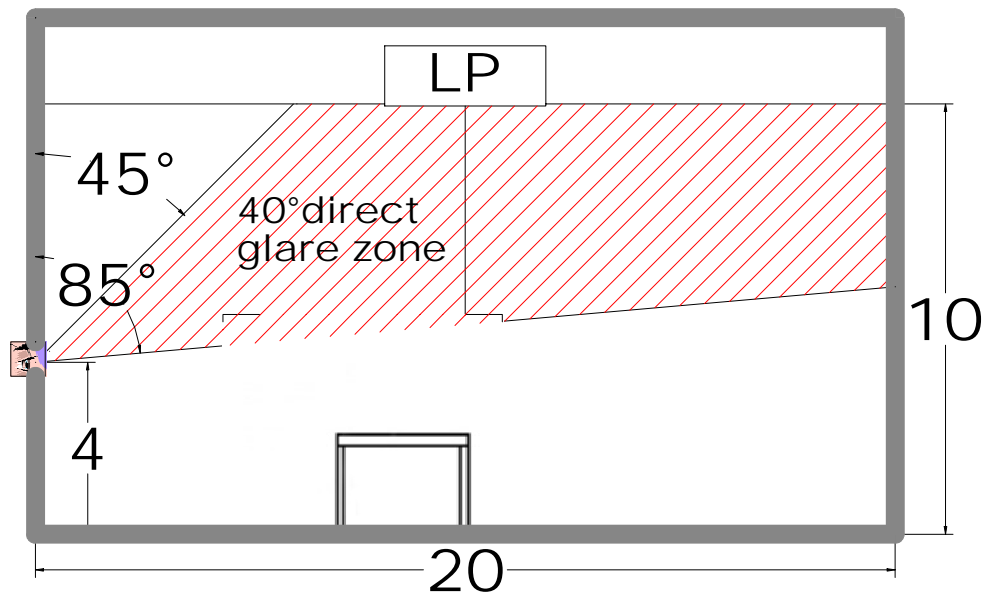


Fig. 44. Transversal section of test model with observer evaluating glare. Direct glare zone highlighted.

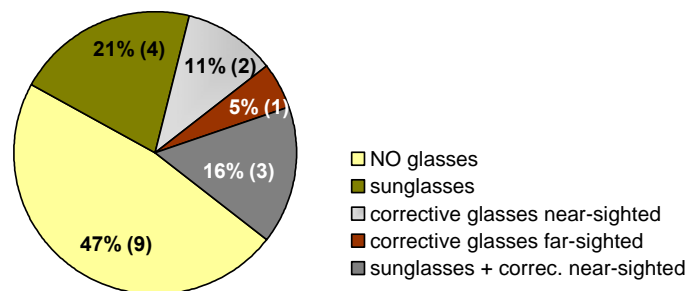


Fig. 45. Question #17: Do you use some kind of glasses? Please specify all that apply.

When they were asked to choose between the two models due to uniformity of daylight distribution, all of them picked model #2. They also preferred model #2 as the place where they would like to work.

Suggestions were made to improve lighting conditions. All of the comments for model #1 were towards illuminating the back, whether with electric light or daylight, this last one using a skylight, a redirecting device, or another window on the back wall. Regarding model #2, 95% preferred to leave it as it was, and someone suggested adding



some shading device, such as an internal light shelf, that might help reduce the excessive light level near the window.

It can be concluded that almost all the people preferred the space with the daylighting system, mainly due to the uniformity of lighting levels and the adequate amount of light at the rear of the space which caused them to feel comfortable and to prefer that space as their working environment if they could make the choice.

## CHAPTER V

### CONCLUSIONS AND FUTURE WORK

#### 5.1. CONCLUSIONS ABOUT THE USE OF LIGHT PIPES AS A MEANS TO ILLUMINATE DEEP PLANS

##### 5.1.1. Conclusions about Illuminance Values

The light pipe system corroborates to be an effective resource to provide lighting levels of 300 lux and above at the back part of the space (15 ft to 30 ft), with a small glazing area that minimizes heat gain. The workplane illuminance values measured from December to March on clear days are satisfactory ( $\leq 300$  lux), without the necessity of turning on the electric light, for about six hours with the diffuser Mylar®, and for four hours with Barrisol®. Nevertheless, from 10 am to 2 pm, light levels with Mylar® show to be above the IESNA recommendations for offices with VDT screens (more than 500 lux). Therefore, the system confirms to be optimum predominantly for sunny skies, although some improvement on the illuminance values was shown on overcast days as well. Nevertheless, this upgrading can be achieved only with semi-opened blinds at the side window and exterior illuminance levels of above 40,000 lux which fulfills recommended illuminance levels for visual tasks ( $\leq 300$  lux) in the room.

As for the uniformity on the lighting distribution, the light pipe system shows to have less contrast gradient than the reference case, and it shows flatter curves at the workplane level along the longitudinal middle section of the space. Still, conditions in the room equipped with the light pipe could be improved. A possible suggestion to improve uniformity as well as required illuminance levels for office with VDT screens would be a combination of the diffuser Barrisol®, or something similar, with some shading device such as louvers at the façade plane to give a better uniformity in the entire space. Another suggestion towards accommodating lighting levels and achieving a uniform light distribution could be to divide the emitter area in order to combine diffusers with different characteristics.

As some work regarding raytracing was done, it was noticed that approximately from 9:30am to 11am in the morning and from 1:30pm to 3:30pm in the afternoon, sunrays bounce from side to side, having their output at the first part of the light pipe emitter, thus illuminating side walls and the area at 18 ft more than the back. Around noon, the sunbeams headed directly towards the back, hence illuminating brightly the middle part of the back wall and increasing light levels primarily in the middle of the back of the workplane. An annual observation needs to be followed to study the performance of the side reflectors that were designed for equinoxes and summer solstice, to see the contribution of oblique angles.

### **5.1.2. Conclusions about Design and Materials Used**

Regarding the materials used in the light pipe, the high reflective film used proved to be difficult to handle, and some wrinkles stayed despite the efforts done to keep the film straight and unpolluted. Hence, a better choice would be a film that comes with an adhesive side, like the one 3M used to manufacture with the name “Silverlux,” or the use of some metal sheet with a high reflective coating.

The assembling method of the facade demonstrated to be a little cumbersome for maintenance, since the entire light pipe had to be removed every time the lower part of the model needed to be reached. A better option would be to have the light pipe in two pieces, one would be the collector integrated to the façade and the other would be the transport section and the emitter laying on top of the ceiling.

### **5.1.3. Conclusions about Visual Comfort and People Acceptance**

The excess of light entering through the window could be solved by adding some type of exterior shading element at the façade plane, or by reducing the glazing area. Such overload of light was noticed by the people on the survey, but at that time was attributed to the blinds in semi-opened position that allows more light into the room than closed blinds. Still the disproportion is evident in the graphs with closed blinds, as the

curve of illuminance values can reach around 1000 lux next to the window while reaches around 600 lux at the back , depicting a very steep slope between 6 ft and 12 ft (refer to Figure 24 at 12pm).

As mentioned in the glare analysis, there is a possibility of direct glare problem when the light pipe emitter with Mylar® diffuser falls within the field of view, which happens at angles between 45° and 85°. The visual comfort could be compromised if the ratio between luminance values of the VDT screen and the light pipe output are greater than 1:10. A better approximation to recommended luminance ratios should be done by pursuing different settings with a more realistic environment closer to an open plan, such as a bigger space with partitions and furnishings.

At the survey, there was an ample acceptance of the daylighting system over the typical side-lit office, even when the light pipe was not under its full performance due to cloudy or hazy sky conditions. No one noticed glare from the light pipe output, although this may have been due either to the excess of light at the window that trapped all the attention, or to the weaker sun, which made the light pipe output dimmer than on a clear day.

## **5.2. FUTURE WORK**

Further studies should be done towards the assembling of the light pipe and its integration with the other building subsystems. One aspect would be the design of the light pipe towards its industrialization which would involve the use of a more durable material such as metal. This material will have to be able to receive a reflective coating in its interior that will stay flat and will not deteriorate over the time.

Another aspect would be the particular design of the light pipe output to obtain a better integration with the ceiling parts, and the possible introduction of the electric luminaire together in the same assembly.

Of special concern is the integration with electric light using lighting control systems (zoning and dimming controls). For this purpose, the placement of vertical

sensors will be useful to evaluate illuminance in the vertical plane, since some dimming controls are positioned in that way.

This study has considered an open-plan office configuration. First steps on furniture placement and partitions have been done here, but this aspect needs to be followed as different partition heights and furniture distributions may affect the performance of the light pipe system.

Finally, for accuracy and practicality on developing all the further studies mentioned above, it is recommended to build a full-scale mock-up of a totally equipped open-plan office.

## REFERENCES

Aizenberg, J.B., 1997. Principal new hollow light guide system “Heliobus” for daylighting and artificial lighting of central zones of multi storey buildings. In: Proceedings of the 4<sup>th</sup> International Conference on Energy Efficient Lighting—Right Light 4, 19–21 November, Copenhagen, Denmark, pp. 239–243.

ANSI/IESNA, 2004. American National Standard Practice for Office Lighting, RP-1-04. Illuminating Engineering Society of North America, New York, NY.

Baker, N., Steemers, K., 2002. Daylight Design of Buildings, James & James, London, UK.

Beltrán, L.O., Lee, E.S., Selkowitz, S.E., 1997. Advanced optical daylighting systems: light shelves and light pipes. *Journal of the Illuminating Engineering Society* 26 (2), 91–106.

Beltrán, L.O., Lee, E.S., Papamichael, K.M., Selkowitz, S.E., 1994. The design and evaluation of three advanced daylighting systems: light shelves, light pipes and skylights. LBL Report 34458, Lawrence Berkeley Laboratory, Berkeley, CA. Available from <http://btech.lbl.gov/papers/34458.pdf>

Benya, J., Heschong, L., Miller, N., Clanton, N., 2003. Lighting Design Considerations. In: *Advanced Lighting Guidelines, 2003 Edition*. New Buildings Institute, CA. pp. 7, 11. Available from <http://www.newbuildings.org/lighting.htm>

Berrutto, V., Fontoynt, M., 1995. Applications of CCD cameras to lighting research: review and extension to the measurement of glare indices. In: Proceedings of the 23rd Session of the Commission Internationale De L'eclairage (CIE), 1–8 November, New Delhi, India, pp. 192–195.

Boyce, P., Hunter, C., Howlett, O., 2003. The Benefits of Daylight through Windows. Lighting Research Center, Rensselaer Polytechnic Institute, Troy, NY.

Boyce, P., 2003. *Human Factors in Lighting*, 2<sup>nd</sup> ed. Taylor & Francis, London, UK.

Carter, D.J., 2002. The measured and predicted performance of passive solar light pipe systems. *Lighting Research Technology* 34 (1), 39–52.

CIBSE, 1999. *Daylighting and Window Design*. CIBSE lighting guide LG10, Chartered Institution of Building Services Engineers, London, UK.

Chirarattananon, S., Chedsiri, S., Renshen, L., 2000. Daylighting through light pipes in the tropics. *Solar Energy* 69 (4), 331–341.

Compagnon, R., 2002. *Advanced Daylighting Systems*, Chapter 9. In: Baker, N., Steemers, K. (Authors), *Daylight Design of Buildings*, James & James, London, UK.

Courret, G., Scartezzini, J.L., Francioli, D., Meyer, J. J., 1998. Design and assessment of anidolic light-duct. *Energy and Buildings* 28, 79–99.

Coutelier, B., Dumortier, D., 2002. Luminance Calibration of the Nikon Coolpix 990 digital camera. In: *Proceedings of the 3rd European Conference on Energy Performance and Indoor Climate in Buildings*, 23-26 October, Lyon, France, pp. 697–702.

Crisp, V., Littlefair, P., Cooper, I., McKennan, G., 1988. Daylighting as a passive solar energy option: an assessment of its potential in non-domestic buildings. Building Research Establishment, Report BR129, Garston, UK.

Culp, J., Schoen, D., 1999. *Image analysis procedures and supplemental tools*. CERES, Ball State University. Based on: *Interior Illuminance, Daylight Controls and Occupant Response*, Vital Signs Resource Package by Schiler M., Japee, S., USC. Available from <http://www.bsu.edu/classes/culp/litestuff/040703bsumanual.pdf>

Debevec, P., Malik, J., 1997. Recovering high dynamic range radiance maps from photographs. In: *Proceedings SIGGRAPH '97*, 3-8 August, Los Angeles, CA, pp. 369–378.

Garcia-Hansen, V., Edmonds, I., 2003. Natural illumination of deep-plan office buildings: light pipe strategies. In: *Proceedings of the ISES Solar World Congress*, 14-19 June, Göteborg, Sweden.

Garcia-Hansen, V., Edmonds, I., Hyde, R., 2001. The use of light pipes for deep plan office buildings — a case study of Ken Yeang's bioclimatic skyscraper proposal for KLCC, Malaysia. In: 35th Annual Conference of the Australian and New Zealand Architectural Science Association, Wellington, New Zealand. Available from [http://www.csdesign.epsa.uq.edu.au/filebase/10200.Uqsdf/10341.Serving\\_in/10556.PapersAndP/notcontent/10598.LightPipe.pdf](http://www.csdesign.epsa.uq.edu.au/filebase/10200.Uqsdf/10341.Serving_in/10556.PapersAndP/notcontent/10598.LightPipe.pdf)

Grimme, F. W., Laar, M., 2002. Solar radiation & orientation as a key information for bio-climatic design. In: Institute of Technology in the Tropics (Eds.), Technology Ressource Management & Development — Scientific Contributions for Sustainable Development, Vol. 1. Cologne, Germany. [ittpub300102\\_4.pdf](http://www.tt.fh-koeln.de/e/itt/publications/index.htm). Available from <http://www.tt.fh-koeln.de/e/itt/publications/index.htm>

Heschong, L., Mahone, D., 2003a. Windows and Classrooms: a Study of Student Performance and the Indoor Environment. Research Report for California Energy Commission, San Francisco, CA. Available from [http://www.energy.ca.gov/reports/2003-11-17\\_500-03-082\\_A-08.PDF](http://www.energy.ca.gov/reports/2003-11-17_500-03-082_A-08.PDF)

Heschong, L., Mahone, D., 2003b. Windows and Offices: a Study of Office Worker Performance and Indoor Environment. Research Report for California Energy Commission, San Francisco, CA. Available from [http://www.energy.ca.gov/reports/2003-11-17\\_500-03-082\\_A-09.PDF](http://www.energy.ca.gov/reports/2003-11-17_500-03-082_A-09.PDF)

Hygge, S., Löfberg, H., 1999. Post occupancy evaluation of daylight in buildings. A report of IEA SHC Task 21 / ECBCS Annex 29. Published by KHT, Royal Institute of Technology, Centre for Built Environment, Gavle, Sweden.

International Energy Agency IEA, 2000. Daylight in Buildings: a Source Book on Daylighting Systems and Components. A report of the International Energy Agency Solar Heating and Cooling Programme Task 21, Energy Conservation in Buildings & Community Systems, Annex 29 (IEA SHC Task 21 / ECBCS Annex 29). Available from <http://www.iea-shc.org/task21/index.html>

Illuminating Engineering Society of North America IESNA, M. Rea (Ed.), 2000. Lighting Handbook: Reference and Application, 9<sup>th</sup> ed. IESNA. New York, NY.



Jenkins, D., Muneer T., 2003. Modelling light-pipe performances: a natural daylighting solution. *Building and Environment* 38, 965–972.

Kischkoweit-Lopin, M., 2002. An overview of daylighting systems. *Solar Energy* 73 (2), 77–82.

Lawrence Berkeley National Laboratory LBNL, James J. Hirsch & Associates, 2005. DOE-2.2 Building Energy Use and Cost Analysis Program, Volume 4: Libraries and Reports.

Littlefair, P.J., 1996. *Designing with Innovative Daylighting*. Construction Research Communication Ltd, London, UK.

McNicholl, A., Lewis, O. (Eds.), 1994. *Daylighting in Buildings*. Energy Research Group, University College, Dublin, Ireland, for the European Commission Directorate General for Energy (DGXVII), A THERMIE Programme Action.

NOAA, 2004. Cloudiness - Mean Number of Days (Clear, Partly Cloudy, Cloudy). Available from <http://www.ncdc.noaa.gov/oa/climate/online/ccd/clpcdy.txt>

NOAA, 2005. College Station Climate Data, 2004 Monthly Data. Available from <http://www.srh.noaa.gov/hgx/climate/cil.htm>

O'Connor, J., Lee, E., Rubinstein, F., Selkowitz, S., 1997. In: *Tips for Daylighting with windows - The Integrated approach*. Building Technologies Program, Energy and Environment Division of the Lawrence Berkeley National Laboratory. Available from <http://eetd.lbl.gov/btp/pub/designguide/dlg.pdf>

Oakley, G., Riffat, S.B., Shao, L., 2000. Daylight performance of light pipes. *Solar Energy* 69 (2), 89–98.

Oliveira, A., Silva, A., Afonso, C., Varga, S., 2001. Experimental and numerical analysis of natural ventilation with combined light/vent pipes. *Applied Thermal Engineering* 21, 1925–1936.

Peron, F., Canziani, R., Rossi, G., 2004. Daylight and energy performances of a new type of light pipe. *Energy and Buildings* 36, 1163–1176.

Robbins, C., 1986. *Daylighting Design and Analysis*, Van Nostrand Reinhold Company, New York, NY.

Scartezzini, J.L., Courret, G., 2002. Anidolic daylighting systems. *Solar Energy* 73 (2), 123–135.

Schiller, M., Japee, S., Ander, G., 1995. A method of post occupancy glare analysis for building energy performance analysis. In: *Proceedings of the American Solar Energy Conference*, 15-20 July, Minneapolis, MN, vol. 20, pp. 25–32.

Selkowitz, S., Lee, E. S., 1998. Advanced fenestration systems for improved daylight performance. In: *Proceedings of International Daylighting Conference 1998*, 11-13 May, Ottawa, Canada, pp. 341–348.

Shao, L., Riffat, S. B., 2000. Daylighting using light pipes and its integration with solar heating and natural ventilation. *Lighting Res. Technology* 32 (3), 133–139.

Spitzglass, M., 1983. State of the Art in Scale-Model Photometry for Evaluating Daylighting in Buildings. In: Vonier, T. (Ed.), *Proceedings of the International Daylighting Conference*, 16-18 February, Phoenix, AZ, pp. 289–290.

Stein, B., Reynolds, J., 2000. *Mechanical and Electrical Equipment for Buildings*, 9<sup>th</sup> edition. John Wiley & Sons, New York, NY.

Ward, G., 2001. High Dynamic Range Imaging. In: *Proceedings of the 9th Color Imaging Conference*, 5-9 November, Scottsdale, AZ, pp. 9–16.

Whitehead, L.A., Scott, J.E., Lee, B., York, B., 1986. Large-scale core daylighting by means of a light pipe. In: *Proceedings II of International Daylighting Conference*, 4-7 November, Long Beach, CA, pp. 416–419.

Wilson, M., Jacobs, A., Solomon, J., Pohl, W., Zimmermann, A., Tsangrassoulis, A., Fontoynt, M., 2002. Creating sunlight rooms in non-daylit spaces. In: *Proceedings of the 5th International Conference on Energy Efficient Lighting—Right Light 5*, 29-31 May, Nice, France, paper ID RL5#49.

**APPENDIX A****TRANSMITTANCE OF VENETIAN BLINDS**

Table A-1  
Transmittance of Venetian blinds in closed position

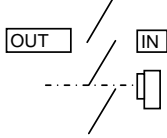

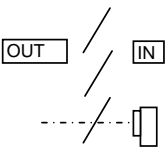
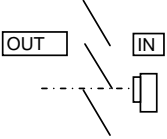

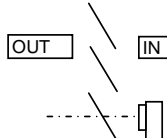
<b>CLOSED BLINDS Transmittance</b>					
<b>Conditions</b>					
<b>Date</b>	Nov. 6, 2004				
<b>Solar Time</b>	15:32				
<b>Outdoor conditions</b>	sunny but not direct sun falling on the test setup				
<b>Procedure</b>	Illuminance measurements taken at 1/2" from the blind plane with a Konica-Minolta Light Meter, model T-10.				
<b>Blinds position</b>	<b>with</b>	<b>without</b>	<b>Result</b>	<b>Picture</b>	
	276	1225	0.23		
	314	1232	0.25		
	316	1242	0.25		
	303	1199	0.25		
	294	1175	0.25		
			<b>0.25</b>		
	229.1	1073	0.21		
	234.7	1064	0.22		
	231.5	1059	0.22		
	213.5	1000	0.21		
	213.3	1013	0.21		
	191.2	932	0.21		
	199.3	941	0.21		
			<b>0.21</b>		
	218.3	1242	0.18		
	221.6	1242	0.18		
	213.1	1236	0.17		
	224.8	1237	0.18		
	209.1	1228	0.17		
			<b>0.18</b>		
	149.3	1066	0.14		
	170.2	1058	0.16		
	209.2	1210	0.17		
	195.4	1214	0.16		
	180.1	1147	0.16		
			<b>0.16</b>		
<b>Average Transmittance of 4 CLOSED BLINDS positions</b>				<b>0.20</b>	

Table A-2  
Transmittance of Venetian blinds in opened and semi-opened positions

OPENED / SEMI-OPENED BLINDS Transmittance				
<b>Condition 1</b>				
<b>Date</b>	Nov. 22, 2004			
<b>Solar Time</b>	12:00			
<b>Outdoor conditions</b>	overcast			
<b>Procedure</b>	Illuminance measurements taken at 1/2" from the blind plane with a Konica-Minolta Light Meter, model T-10.			
Blinds position (~45°)	with	without	Result	Picture
	156.9	531	0.30	
	151.8	488	0.31	
	142.9	444	0.32	
	141.2	437	0.32	
	145.1	454	0.32	
	155.9	494	0.32	
			<b>0.31</b>	
	141.3	387	0.37	
	123.3	368	0.34	
	124.8	365	0.34	
	130.3	375	0.35	
	144.7	412	0.35	
	164.8	457	0.36	
	178.6	506	0.35	
		<b>0.35</b>		
<b>Condition 2</b>				
<b>Date</b>	Dec. 11, 2004			
<b>Solar Time</b>	12:10			
<b>Outdoor conditions</b>	Sunny			
<b>Procedure</b>	Illuminance measurements taken at 1/2" from the blind plane with a Konica-Minolta Light Meter, model T-10. Blinds were tilted to block the sun at noon with the minimum angle necessary for this purpose			
Blinds position (~horizontal)	with	without	Result	Picture
	19870	84600	0.23	
	19580	84700	0.23	
	19760	84800	0.23	
	20070	85300	0.24	
	20890	85300	0.24	
	20360	85500	0.24	
			<b>0.24</b>	
	20620	85700	0.24	
	20790	86600	0.24	
	21340	85900	0.25	
	21360	87100	0.25	
	20410	86300	0.24	
	20700	87300	0.24	
			<b>0.24</b>	
<b>Avg Transmittance of 4 OPENED/SEMI-OPENED blinds positions</b>				<b>0.29</b>

**APPENDIX B**  
**SUN-PATH DIAGRAM**

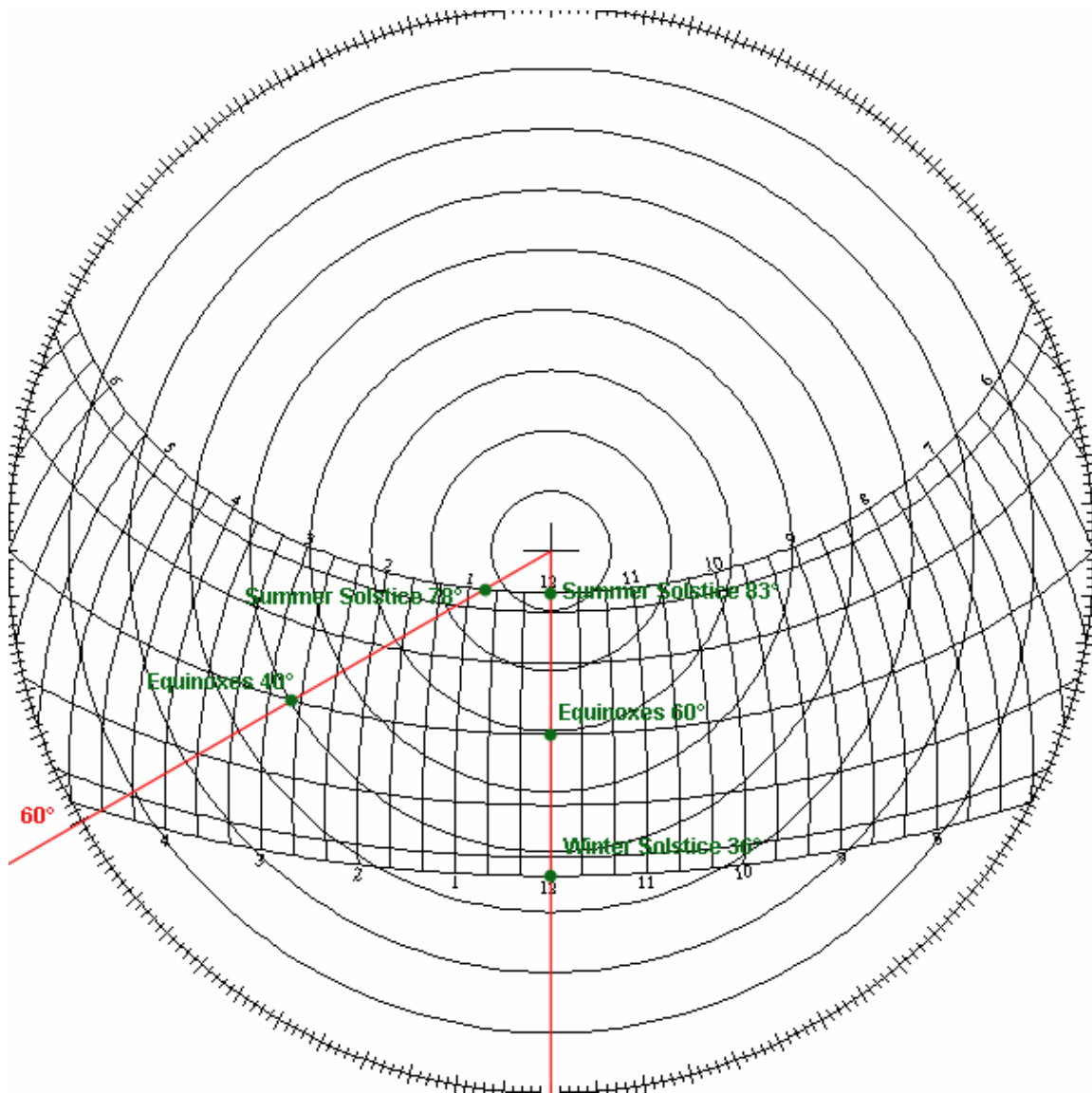


Fig. B-1. Sunpath diagram with altitude angles for the design of central and side reflectors. The façades were oriented towards South, College Station (lat: 30°36'N), USA.

**APPENDIX C**

**“SILVER III” BY SOUTHWALL TECHNOLOGIES**



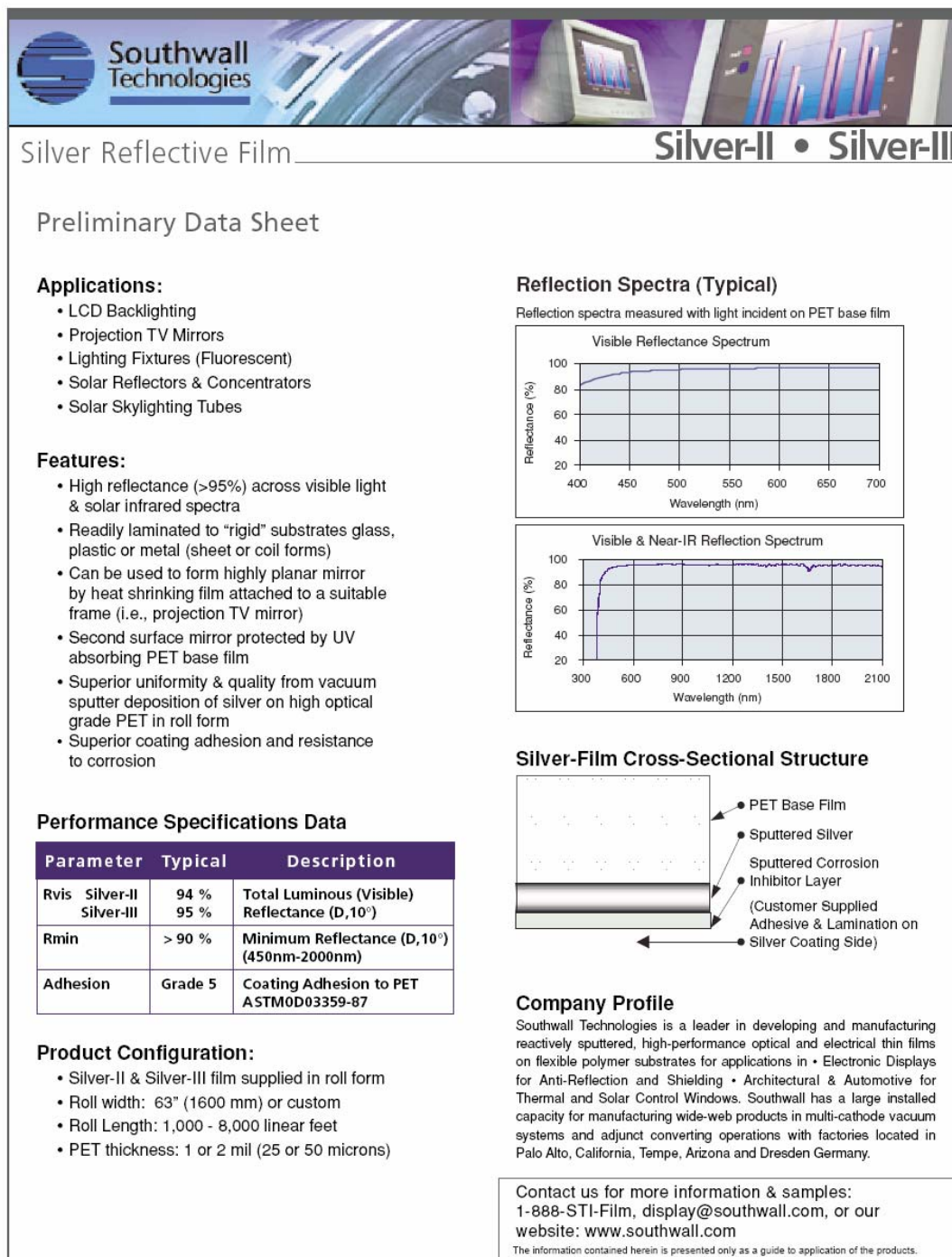


Fig. C-1. Specification sheet of reflective film, “Silver III” by Southwall Technologies, used in the interior of the light pipe.

**APPENDIX D****STUDY TO FIND MOUNTING TECHNIQUE FOR “SILVER III”**

*Purpose of the experiment:* to measure the reflectivity of different mounting options for the reflective film “Silver III” in order to find the mounting technique that gives best reflectivity.

*Date:* September 22, 2004

*Place:* enclosed office with no natural light.

*Light source:* desk lamp with a halogen lamp G4 (miniature Quartz Halogen lamp), 20W.

Note: Halogen lamps offer high-brightness, high-color temperature and minimum lumen depreciation during lamp life. They provide broad band spectral radiation ranging from the ultraviolet, through the visible, and into the infrared.

*Setting:* two principal axes were traced on the horizontal wood-board: the X axis coincident with the center of the light source, and the Y axis traced where the center beam of the light source hit the wood-board (deduced from Figure D-1). The position in the vertical plane, Z axis, for placing the light meter facing down was selected at approximately half of the total height from the light source to the wood-board. In the axis X, the light meter was placed in between the range of the reflected beams. The approximate light-reflected angles and distances are shown in Figure D-1, and the general setup in Figure D-2.

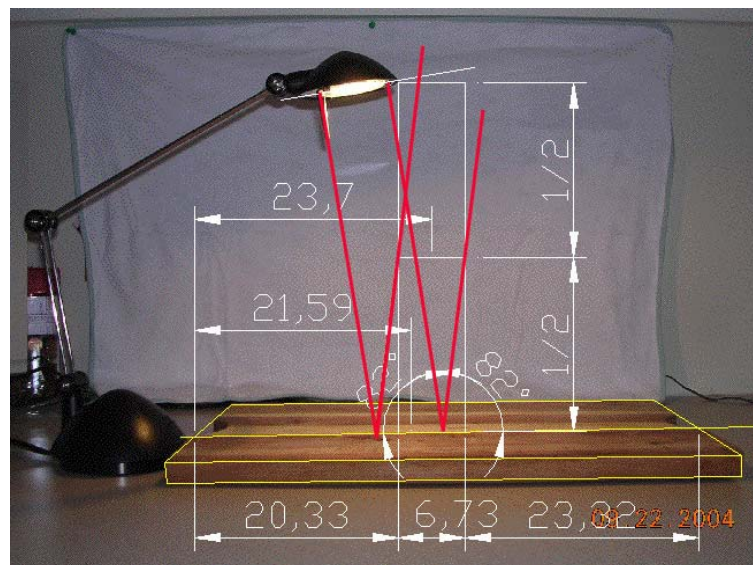


Fig. D-1. Approximate angles of reflected light and setup measures [cm].



Fig. D-2. Setup for experiment to measure reflectivity of different types of “Silver III” mountings.

*Samples:* five different types of mountings using the reflective film “Silver III” by Southwall were tested to find the mounting with the best specular reflectivity. A sixth sample consisting of a plexiglass mirror was also tested. Figures D-3 and D-4 show them under different lighting conditions.

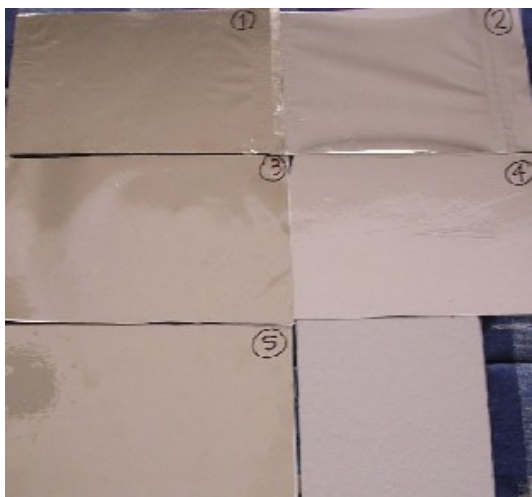


Fig. D-3. “Silver III” mountings photographed under diffuse light.



Fig. D-4. “Silver III” mountings photographed with flash.

*Instrumentation used:* illuminance Meter MINOLTA T-10.

*Procedure:* for each sample, the procedure consisted of placing the light meter facing up and measuring the incident light at the level of the wood-board. After that, the corresponding sample was placed centered on the intersection of X and Y axes. The light meter was placed facing down at half of the total height from the light source to the wood-board. Two measurements were taken: one at the marked position on top of the boxes, and the second at the place where the highest value was found by moving the meter within the sample limits. Figure D-5 and D-6 show the steps of the procedure.



Fig. D-5. Measuring incident light with light meter facing up at wood-board level.



Fig. D-6. Measuring reflected light with light meter facing down half way from the light source.

*Experiment results:* the reflectivity for different mounting types is shown in Table D-1. The mounting with the best reflectivity was the one with only the edges adhered with a removable adhesive.

Table D-1  
 Reflectivity of different “Silver III” mountings

Sample #	Type of mounting	Incident light (Lux)	Reflected light (Lux) at Fixed position	Reflected light (Lux) Maximum valued found	% at fixed position	% with max value
1	edges w/double tack	835	390	390	47	47
<b>2</b>	<b>edges w/monoadhesive removable</b>	<b>838</b>	<b>555</b>	<b>564</b>	<b>66</b>	<b>67</b>
3	staples on the edges	837	316	394	38	47
4	sprayglue	819	380	530	46	65
5	sheet double tack archival	815	367	383	45	47
6	plexiglass mirror	832	365	371	44	45

**APPENDIX E**  
**SUNLIGHT AVAILABILITY**

Table E-1  
Sunlight availability for Fort Worth, TX . Monthly average at every hour.

HOUR, SOLAR	SUNLIGHT AVAILABILITY FOR FORT WORTH, TX												ANNUAL FRACTION	ANNUAL HOURS		
	JAN	FEB	MAR	APR	MAY	JUN	JUL	AUG	SEP	OCT	NOV	DEC				
05:00-06:00	0.000	0.000	0.000	.128	.631	.716	.984	.032	0.000	0.000	0.000	0.000	0.000	0.000	.429	76.4
06:00-07:00	0.000	.274	.265	.405	.539	.542	.834	.698	.855	.416	0.000	0.000	0.000	0.000	.479	147.0
07:00-08:00	.280	.427	.554	.457	.549	.617	.772	.781	.780	.604	.511	.322	.322	.322	.555	202.7
08:00-09:00	.503	.557	.601	.547	.564	.698	.858	.875	.829	.665	.602	.501	.501	.501	.651	237.5
09:00-10:00	.562	.629	.624	.540	.674	.717	.941	.884	.826	.631	.638	.591	.591	.591	.689	251.4
10:00-11:00	.562	.617	.648	.568	.728	.774	.926	.820	.815	.694	.639	.660	.660	.660	.705	257.3
11:00-12:00	.576	.626	.738	.613	.708	.809	.918	.818	.786	.752	.654	.685	.685	.685	.724	264.4
12:00-13:00	.600	.662	.766	.572	.678	.840	.805	.868	.743	.738	.707	.637	.637	.637	.718	262.2
13:00-14:00	.575	.648	.738	.624	.665	.811	.791	.825	.788	.777	.731	.628	.628	.628	.717	261.8
14:00-15:00	.576	.597	.740	.618	.682	.892	.774	.811	.790	.764	.735	.633	.633	.633	.718	262.1
15:00-16:00	.566	.571	.681	.650	.668	.845	.798	.834	.737	.800	.683	.630	.630	.630	.706	257.8
16:00-17:00	.439	.490	.599	.597	.611	.796	.860	.850	.746	.723	.597	.404	.404	.404	.643	234.8
17:00-18:00	0.000	.304	.448	.538	.608	.717	.856	.858	.792	.399	0.000	0.000	0.000	0.000	.548	168.2
18:00-19:00	0.000	0.000	0.000	.067	.714	.847	.982	0.000	0.000	0.000	0.000	0.000	0.000	0.000	.449	80.0
MONTHLY AVERAGE	.524	.533	.617	.495	.644	.759	.864	.766	.791	.664	.650	.569	.569	.569		
MONTHLY FRACTION	.489	.533	.598	.495	.644	.741	.864	.711	.715	.664	.563	.569	.569	.569		
MONTHLY AVG. HOURS OF SUNLIGHT PER DAY (HR)	5.2	6.4	7.4	6.9	9.0	10.6	12.1	10.0	9.5	8.0	6.5	5.7	5.7	5.7		



Table E-2  
Sunlight availability for Fort Worth, TX . Monthly average for different buildings' schedules

STANDARD WORK YEAR	SUNLIGHT AVAILABILITY BY STANDARD WORK YEAR FOR FORT WORTH, TX												ANNUAL (SA_S)
	JAN	FEB	MAR	APR	MAY	JUN	JUL	AUG	SEP	OCT	NOV	DEC	
07:00-16:00	.480	.561	.636	.559	.646	.755	.842	.821	.795	.684	.590	.529	.658
07:00-17:00	.476	.554	.632	.563	.642	.758	.843	.824	.790	.688	.591	.517	.657
07:00-18:00	.437	.533	.617	.561	.640	.755	.844	.827	.791	.664	.541	.474	.640
07:00-19:00	.403	.492	.569	.523	.645	.762	.855	.763	.730	.613	.500	.438	.608
08:00-16:00	.533	.593	.677	.577	.657	.778	.843	.835	.788	.714	.656	.587	.686
08:00-17:00	.524	.582	.669	.579	.653	.780	.844	.837	.784	.715	.650	.569	.682
08:00-18:00	.476	.557	.649	.575	.649	.774	.845	.838	.785	.686	.591	.517	.662
08:00-19:00	.437	.511	.595	.533	.654	.780	.857	.769	.719	.629	.541	.474	.625
09:00-16:00	.565	.613	.692	.592	.671	.798	.851	.842	.789	.728	.674	.621	.703
09:00-17:00	.551	.600	.682	.592	.664	.798	.852	.843	.784	.727	.665	.597	.696
09:00-18:00	.496	.570	.658	.587	.659	.790	.853	.844	.785	.694	.599	.537	.673
09:00-19:00	.451	.518	.598	.539	.664	.795	.865	.768	.714	.631	.544	.488	.631

Table E-3  
 Cloudiness - Mean number of days . Data from 54 years for Austin, TX. Data from the year 2003 for College Station, TX.

Cloudiness - Mean Number of Days (Clear, Partly Cloudy, Cloudy)	JAN		FEB		MAR		APR		MAY		JUN		JUL		AUG		SEP		OCT		NOV		DEC		ANNUAL ANNUAL.in % % of Cl+PC																	
	CL	PC	CD	CL	PC	CD	CL	PC	CD	CL	PC	CD	CL	PC	CD	CL	PC	CD	CL	PC	CD	CL	PC	CD																		
COLLEGE STATION, TX	2003	11	5	15	13	3	13	11	9	11	15	8	7	9	19	3	16	13	1	29	2	0	31	0	0	24	5	1	11	20	0	10	7	13	19	6	5	199	97	69	81	
AUSTIN, TX	# of YRS	54	9	6	16	8	6	14	9	8	15	8	8	15	8	8	15	13	8	15	7	12	13	6	12	14	5	11	11	9	12	9	11	7	12	10	6	15	115	114	136	63

**APPENDIX F**

**EQUIPMENT USED FOR RESEARCH MONITORING**

# LI-210SA PHOTOMETRIC SENSOR

LI-COR, Inc. Toll Free: 1-800-447-3576 (U.S. & Canada) • Phone: 402-467-3576 • FAX: 402-467-2819 • E-mail: envsales@env.licor.com • Internet: <http://www.licor.com>

## MEASURES ILLUMINANCE AS RELATED TO THE CIE STANDARD OBSERVER CURVE

The LI-210SA Photometric Sensor utilizes a filtered silicon photodiode to provide a spectral response that matches the CIE curve within  $\pm 5\%$  with most light sources. This photodiode and filter combination is placed within a fully cosine-corrected sensor head to provide the proper response to radiation at various angles of incidence.

Some of the applications for the LI-210SA Photometric Sensor include interior and industrial lighting, outdoor illuminance, passive solar energy, architecture and lighting models, illumination engineering, and biological sciences that require illuminance measurements. The LI-210SA is a research grade photometric sensor that is very reasonably priced.

## LI-210SA SPECIFICATIONS

**Absolute Calibration:**  $\pm 5\%$  traceable to NBS.

**Sensitivity:** Typically 30  $\mu\text{A}$  per 100 klux.

**Linearity:** Maximum deviation of 1% up to 100 klux.

**Stability:**  $< \pm 2\%$  change over a 1 year period.

## PHOTOMETRIC SENSORS

Photometry refers to the measurement of visible radiation (light) with a sensor having a spectral responsivity curve equal to the average human eye. This curve is known as the CIE Standard Observer Curve (photopic curve).

Photometric sensors are used to measure lighting conditions where the eye is the primary receiver, such as illumination of work areas, interior lighting, television screens, etc. Although photometric measurements have been used in the past in plant science, PPF and irradiance are the preferred measurements.

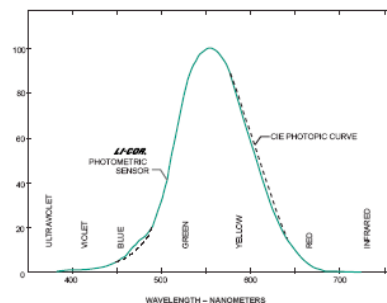


Figure 1. Typical spectral response of LI-COR Photometric Sensors vs. Wavelength and the CIE Standard Observer Curve.

**Response Time:** 10  $\mu\text{s}$ .

**Temperature Dependence:**  $\pm 0.15\%$  per  $^{\circ}\text{C}$  maximum.

**Cosine Correction:** Cosine corrected up to  $80^{\circ}$  angle of incidence.

**Azimuth:**  $< \pm 1\%$  error over  $360^{\circ}$  at  $45^{\circ}$  elevation.

**Tilt:** No error induced from orientation.

**Operating Temperature:**  $-20$  to  $65^{\circ}\text{C}$ .

**Relative Humidity:** 0 to 100%.

**Detector:** High stability silicon photovoltaic detector (blue enhanced).

**Sensor Housing:** Weatherproof anodized aluminum case with acrylic diffuser and stainless steel hardware.

**Size:** 2.38 Dia.  $\times$  2.54 cm H (0.94"  $\times$  1.0").

**Weight:** 28 g (1 oz.).

**Cable Length:** 10 ft. standard.

## ORDERING INFORMATION

The LI-210SA Photometric Sensor cable terminates with a BNC connector that connects directly to the LI-250 Light Meter or LI-1400 DataLogger. The 2290 Millivolt Adapter should be ordered if the LI-210SA will be used with a strip chart recorder or datalogger that measures millivolts. The 2290 uses a 604 Ohm precision resistor to convert the LI-210SA output from microamps to millivolts. The Photometric Sensor can also be ordered with bare leads (without the connector) and is designated LI-210SZ. The 2003S Mounting and Leveling Fixture is recommended for each sensor unless other provisions for mounting are made. Other accessories are described on the Accessory Sheet.

**LI-210SA Photometric Sensor**  
(with BNC connector)

**LI-210SZ Quantum Sensor**  
(with bare leads)

**2003S Mounting and Leveling Fixture**

**2222SB-50 Extension Cable (50 ft.)**

**2222SB-100 Extension Cable (100 ft.)**

**2290 Millivolt Adapter**



Fig. F-1. Specifications of LI-COR LI-210SA photometric sensor.

Shadow band models SBS, by The Eppley Laboratory, Inc.

The Eppley Laboratory manufactures a shading device to be used to block the direct beam illuminance called Shadow Band Stand, Model SBS. It is constructed of anodized aluminum, weighs approximately 24 pounds, and uses a 3" band of approximately 25" diameter to shade the sensor. The declination setting must be adjusted regularly.



Fig. F-2. Shadow band stand by Eppley with two LI-COR photometric sensors, one placed horizontally and one placed vertically. The position and attachment of this last one was especially customized since the shadow band stand is constructed to receive only one sensor placed horizontally.

## CR23X Specifications

Electrical specifications are valid over a -25° to +50°C range unless otherwise specified; non-condensing environment required. To maintain electrical specifications, Campbell Scientific recommends recalibrating dataloggers every two years.

### PROGRAM EXECUTION RATE

Program is synchronized with real-time up to 100 Hz. Two fast (250  $\mu$ s) single-ended measurements can write to final storage at 100 Hz. Burst measurements to 1.5 kHz are possible over short intervals.

### ANALOG INPUTS

DESCRIPTION: 12 differential or 24 single-ended, individually configured. Channel expansion provided through AM16/32 or AM416 Relay Multiplexers and AM25T Thermocouple Multiplexers.

ACCURACY:  $\pm 0.025\%$  of FSR, 0° to 40°C  
 $\pm 0.05\%$  of FSR, -25° to 50°C  
 $\pm 0.075\%$  of FSR, -40° to 80°C; (-XT only)

Note:  $\pm 5 \mu$ V offset voltage error is possible with single-ended (SE) measurements.

### RANGES AND RESOLUTION:

Input Range (mV)	Resolution ( $\mu$ V) Diff. SE	Accuracy (mV) (-25° to 50°C)
$\pm 5000$	166 333	$\pm 5.00$
$\pm 1000$	33.3 66.6	$\pm 1.00$
$\pm 200$	6.66 13.3	$\pm 0.20$
$\pm 50$	1.67 3.33	$\pm 0.05$
$\pm 10$	0.33 0.66	$\pm 0.01$

INPUT SAMPLE RATES: Includes the measurement time and conversion to engineering units. Differential measurements incorporate two integrations with reversed input polarities to reduce thermal offset and common mode errors. Fast measurement integrates the signal for 250  $\mu$ s; slow measurement integrates for one power line cycle (50 or 60 Hz).

Fast single-ended voltage:	2.1 ms
Fast differential voltage:	3.1 ms
Slow single-ended voltage (60 Hz):	18.3 ms
Slow differential voltage (60 Hz):	35.9 ms
Fast differential thermocouple:	6.9 ms

INPUT NOISE VOLTAGE: Typical for  $\pm 10$  mV Input Range; digital resolution dominates for higher ranges.

Fast differential:	0.60 $\mu$ V rms
Slow differential (60 Hz):	0.15 $\mu$ V rms
Fast single-ended:	1.20 $\mu$ V rms
Slow single-ended (60 Hz):	0.30 $\mu$ V rms

COMMON MODE RANGE:  $\pm 5$  V

DC COMMON MODE REJECTION: >100 dB

NORMAL MODE REJECTION: 70 dB @ 60 Hz when using 60 Hz rejection

SUSTAINED INPUT VOLTAGE WITHOUT DAMAGE:  $\pm 16$  Vdc max.

INPUT CURRENT:  $\pm 2.5$  nA typ.,  $\pm 10$  nA max. @ 50°C

INPUT RESISTANCE: 20 Gohms typical

ACCURACY OF BUILT-IN REFERENCE JUNCTION THERMISTOR (for thermocouple measurements):

$\pm 0.25^\circ\text{C}$ , 0° to 40°C
$\pm 0.5^\circ\text{C}$ , -25° to 50°C
$\pm 0.7^\circ\text{C}$ , -40° to 80°C (-XT only)

### ANALOG OUTPUTS

DESCRIPTION: 4 switched, active only during measurement, one at a time; 2 continuous.

RANGE: Programmable between  $\pm 5$  V

RESOLUTION: 333  $\mu$ V

ACCURACY:  $\pm 5$  mV;  $\pm 2.5$  mV (0° to 40°C)

CURRENT SOURCING: 50 mA for switched; 15 mA for continuous

CURRENT SINKING: 50 mA for switched, 5 mA for continuous (15 mA for continuous with Boost selected in P133).

FREQUENCY SWEEP FUNCTION: The switched outputs provide a programmable swept frequency, 0 to 5 V square wave for exciting vibrating wire transducers.

### RESISTANCE MEASUREMENTS

MEASUREMENT TYPES: The CR23X provides ratio-metric measurements of 4- and 6-wire full bridges, and 2-, 3-, and 4-wire half-bridges. Precise, dual polarity excitation using any of the 4 switched outputs eliminates dc errors. Conductivity measurements use a dual polarity 0.75 ms excitation to minimize polarization errors.

ACCURACY:  $\pm 0.02\%$  of FSR ( $\pm 0.015\%$ , 0° to 40°C) plus bridge resistor error.

### PERIOD AVERAGING MEASUREMENTS

DESCRIPTION: The average period for a single cycle is determined by measuring the duration of a specified number of cycles. Any of the 24 SE analog inputs can be used. Signal attenuation and ac coupling are typically required.

### INPUT FREQUENCY RANGE:

Signal peak-to-peak <sup>1</sup>		Min.	Max.
Min.	Max.	Pulse w.	Max Freq. <sup>2</sup>
500 mV	10.0 V	2.5 $\mu$ s	200 kHz
40 mV	2.0 V	10 $\mu$ s	50 kHz
5 mV	2.0 V	62 $\mu$ s	8 kHz
2 mV	2.0 V	100 $\mu$ s	5 kHz

<sup>1</sup>Signals centered around datalogger ground

<sup>2</sup>Assuming 50% duty cycle

RESOLUTION: 12 ns divided by the number of cycles measured

ACCURACY:  $\pm 0.01\%$  of reading

### PULSE COUNTERS

DESCRIPTION: Four 8-bit or two 16-bit inputs selectable for switch closure, high frequency pulse, or low-level AC. Counters read at 10 or 100 Hz.

MAXIMUM COUNT RATE: 2.5 kHz and 25 kHz, 8-bit counter read at 10 Hz and 100 Hz, respectively; 400 kHz, 16-bit counter.

### SWITCH CLOSURE MODE:

Minimum Switch Closed Time: 5 ms  
 Minimum Switch Open Time: 6 ms  
 Maximum Bounce Time: 1 ms open without being counted

### HIGH FREQUENCY PULSE MODE:

Minimum Pulse Width: 1.2  $\mu$ s  
 Maximum Input Frequency: 400 kHz  
 Voltage Thresholds: Count upon transition from below 1.5 V to above 3.5 V at low frequencies. Larger input transitions are required at high frequencies because of input filter with 1.2  $\mu$ s time constant. Signals up to 400 kHz will be counted if centered around +2.5 V with deviations  $\geq \pm 2.5$  V for  $\geq 1.2 \mu$ s.  
 Maximum Input Voltage:  $\pm 20$  V

### LOW LEVEL AC MODE:

Internal ac coupling removes dc offsets up to  $\pm 0.5$  V.  
 Input Hysteresis: 15 mV  
 Maximum ac Input Voltage:  $\pm 20$  V  
 Minimum ac Input Voltage:  
 (Sine wave mV RMS) Range (Hz)

20	1.0 to 1000
200	0.5 to 10,000
1000	0.3 to 16,000

### DIGITAL I/O PORTS

DESCRIPTION: 8 ports selectable as binary inputs or control outputs. Ports C5-C8 capable of counting switch closures and high frequency pulses.

HIGH FREQUENCY MAX: 2.5 kHz

OUTPUT VOLTAGES (no load): high 5.0 V  $\pm 0.1$  V;  
 low < 0.1

OUTPUT RESISTANCE: 500 ohms

INPUT STATE: high 3.0 to 5.5 V; low -0.5 to +0.8 V

INPUT RESISTANCE: 100 kohms

### SDI-12 INTERFACE SUPPORT

DESCRIPTION: Digital I/O Ports C5-C8 support SDI-12 asynchronous communication; up to ten SDI-12 sensors can be connected to each port. Meets SDI-12 Standard version 1.2 for datalogger and sensors mode.

### CE COMPLIANCE (as of 03/02)

STANDARD(S) TO WHICH CONFORMITY IS

DECLARED:

EN55022: 1995 and EN61326: 1998

### EMI and ESD PROTECTION

IMMUNITY: Meets or exceeds following standards:

ESD: per IEC 1000-4-2;  $\pm 8$  kV air,  $\pm 4$  kV contact discharge

RF: per IEC 1000-4-3; 3 V/m, 80-1000 MHz

EFT: per IEC 1000-4-4; 1 kV power, 500 V I/O

Surge: per IEC 1000-4-5; 1 kV power and I/O

Conducted: per IEC 1000-4-6; 3 V 150 kHz-80 MHz

Emissions and immunity performance criteria available on request.

### CPU AND INTERFACE

PROCESSORS: Hitachi 6303; Motorola 68HC708 supports communications.

PROGRAM STORAGE: Up to 16 kbytes for active program; additional 16 kbytes for alternate programs. Operating system stored in 512 kbytes Flash memory.

DATA STORAGE: 1 Mbyte Flash standard. Additional 4 Mbytes Flash available as an option.

DISPLAY: 24-character-by-2-line LCD

SERIAL INTERFACES: Optically isolated RS-232 9-pin interface for computer or modem. CS 9-pin I/O interface for peripherals such as storage modules or CSI modems.

BAUD RATES: Selectable at 300, 1200, 2400, 4800, 9600, 19.2K, 38.4K, and 76.8K. ASCII protocol is one start bit, eight data bits, no parity, one stop bit.

CLOCK ACCURACY:  $\pm 1$  minute per month, -25° to +50°C;  $\pm 2$  minutes per month, -40° to +85°C

### SYSTEM POWER REQUIREMENTS

VOLTAGE: 11 to 16 Vdc

TYPICAL CURRENT DRAIN: 2 mA quiescent with display off (2.5 mA max); 7 mA quiescent with display on, 45 mA during processing, and 70 mA during analog measurement.

INTERNAL BATTERIES: 10 Ahr alkaline or 7 Ahr rechargeable base. 1800 mAh lithium battery for clock and SRAM backup typically provides 10 years of service.

EXTERNAL BATTERIES: Any 11 to 16 Vdc battery may be connected; reverse polarity protected.

### PHYSICAL SPECIFICATIONS

SIZE: 9.5" x 7.0" x 3.8" (24.1 cm x 17.6 cm x 9.6 cm). Terminal strips extend 0.4" (1.0 cm) and terminal strip cover extends 1.3" (3.3 cm) above the panel.

WEIGHT: 3.6 lbs (1.6 kg) with low-profile base  
 8.3 lbs (3.8 kg) with alkaline base  
 10.7 lbs (4.8 kg) with rechargeable base

### WARRANTY

Three years against defects in materials and workmanship.

We recommend that you confirm system configuration and critical specifications with Campbell Scientific before purchase.



**CAMPBELL SCIENTIFIC, INC.**

815 W. 1800 N. • Logan, Utah 84321-1784 • (435) 753-2342 • FAX (435) 750-9540  
 Offices also located in: Australia • Brazil • Canada • England • France • South Africa • Spain

Copyright © 1998, 2004  
 Campbell Scientific, Inc.  
 Printed January 2004

Fig. F-3. Specifications for CR23X datalogger by Campbell Scientific, Inc.

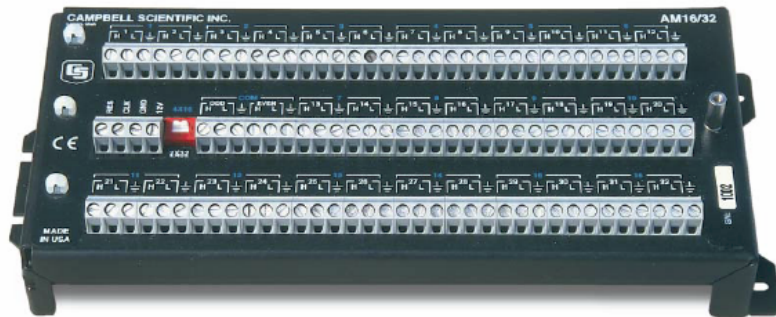


Fig. F-4. Datalogger CR23X by Campbell Scientific, Inc.

## Relay Multiplexer

### Model AM16/32

The AM16/32 Multiplexer increases the number of sensors that can be measured by a CR10(X), CR1000, CR23X, CR5000, or CR7 datalogger. The AM16/32 sequentially multiplexes 16 groups of four lines (a total of 64 lines) through four common (COM) terminals. A manual switch setting allows it to multiplex 32 groups of two lines (also a total of 64 lines) through two COM terminals. Compatible sensors include thermistors, potentiometers, load cells, strain gages, vibrating wires, water content reflectometers, and gypsum soil moisture blocks. The AM16/32 not only increases system channel capacity, it also reduces the cost of cabling individual sensors on long wire runs. The maximum distance between the datalogger and the AM16/32 is determined by the sensors used, the datalogger's scan rate, and the cable used in the application.



*The AM16/32 can be manually configured to multiplex channels in 16 groups (four lines at a time) or 32 groups (two lines at a time).*

Fig. F-5. Relay multiplexer AM16/32 by Campbell Scientific, Inc., with explanatory text. This multiplexer was used with the CR23X to increase the number of sensor connections.

Table F-1  
Specifications for Minolta T-10 and T-10M illuminance meters

Model	Illuminance Meter T-10	Illuminance meter T-10M
Type	Multi-function digital illuminance meter with detachable receptor head	
Receptor	Silicon photocell	
Cosine Correction Characteristics	Within +/-1% at 10°; Within +/-2% at 30°; Within +/-6% at 50°; Within +/-7% at 60°; Within +/-25% at 80°	
Illuminance Units	Lux ( $\mu\text{x}$ ) or foot candles (fcd) (switchable)	
Measuring Range	Auto range (Manual 5 range at the time of analog output)	
Measuring Function	Illuminance ( $\mu\text{x}$ ), illuminance different ( $\mu\text{x}$ ), illuminance ratio (%), integrated illuminance ( $\mu\text{x}\cdot\text{h}$ ), integrated time (h), average illuminance ( $\mu\text{x}$ )	
Measuring Range	Illuminance: 0.01 to 299,900 $\mu\text{x}$ (0.001 to 29,990fcd) Integrated illuminance: 0.01 to 999,900 x 103 $\mu\text{x}\cdot\text{h}$ (0.001 to 99,990 x 103fcd $\cdot\text{h}$ / 0.001 to 9999h)	
User Calibration Function	CCF (Color Correction Factor) setting function	
Accuracy	+/-2% +/-1 digit of displayed value (based on Konica Minolta standard)	
Digital Output	RS-232C	
Analog Output	1mV/digit, 3V at maximum reading; Output impedance: 10k $\Omega$ ; 90% response time: FAST setting: 1msec., SLOW setting: 1sec.	
Display	3 or 4 Significant-digit LCD with backlight illumination	
Power Source	2 AA-size batteries / AC adapter (optional)	
Battery Life	72 hours or longer (when alkaline batteries are used) in continuous measurement	
Dimensions (W x H x D)	69 x 174 x 35mm	Main body: 69 x 161.5 x 30mm Receptor: $\varnothing$ 16.5 x 12.5 Cord length: 1m
Weight	200g without battery	205g without battery
Standard Accessories	$\varnothing$ 3.5mm ( $\varnothing$ 1/8 in.) Subminiature Plug for Analog Output, Receptor Cap, Neck Strap, Case, Battery	$\varnothing$ 3.5mm ( $\varnothing$ 1/8 in.) Subminiature Plug for Analog Output, Neck Strap, Case, Battery
Optional Accessories	Receptor Head, Adapter for Multi-point, AC Adapter, Data Processing Software	



# LUMINANCE METERS LS-100/LS-110

**Compact, lightweight, easy-to-use SLR luminance meters with a wide measuring range**

## Luminance Meter LS-100

1° acceptance angle,  
Measuring range: 0.001 to 299,900cd/m<sup>2</sup>  
(0.001 to 87,530fL)



LS-100

### MAIN FEATURES

#### Flareless SLR optical system for accurate measurements

The SLR (single-lens-reflex) optical system allows precise aiming and ensures that the viewfinder shows the exact area to be measured. The optical system is also virtually flareless, eliminating the influence of light from outside the measurement area.

#### Narrow acceptance angle for measurements of small specimens

Acceptance angles of only 1° for **LS-100** and 1/3° for **LS-110** allow accurate measurements of small specimen areas. In addition, optional close-up lenses can be used to measure areas as small as  $\phi 1.3\text{mm}$  when using **LS-100** and  $\phi 0.4\text{mm}$  when using **LS-110**.

#### User calibration and color-correction functions

To increase the versatility of the **LS-100** and **LS-110**, both models are equipped with user calibration and color correction functions. The user calibration function allows the meter to be calibrated to a user-selected standard instead of the preset Minolta standard; this function can also be used to standardize the response of several meters. The color correction function allows the response of the meter to be adjusted when measuring colored specimens.

#### Luminance ratio and peak luminance measurements

In addition to measurements of the present luminance, the **LS-100** and **LS-110** can also determine the percent ratio of the measured luminance to a luminance value stored in memory as well as the peak luminance or luminance ratio measured.

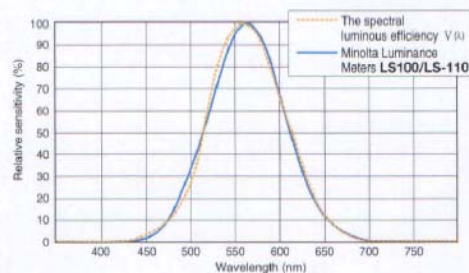
#### RS-232C data communication

Use of the built-in RS-232C interface allows the meter to be connected to a personal computer.

#### Lightweight, compact design powered by a single 9V battery for portability

(Power can also be supplied by optional Data Printer **DP-10**.)

### RELATIVE SPECTRAL RESPONSE



Ideally, the relative spectral responsivity of the luminance meter should match  $V(\lambda)$  of the human eye for photopic vision.

As shown in the graph above, the relative spectral responsivity of Minolta Luminance Meters **LS-100/LS-110** is within 8% ( $f1'$ ) of the CIE spectral luminous efficiency  $V(\lambda)$ .

CIE : Commission Internationale de l'Eclairage  
 $f1'$  (CIE-s symbol) : The degree to which the relative spectral responsivity matches  $V(\lambda)$  is characterized by means of the error  $f1'$ .

### REDUCTION OF FLARE

The degree to which the influence of light from outside the defined measuring area is eliminated is an important factor in the performance of luminance meters. In Minolta Luminance Meters, the flare factor is kept to below 1.5%, even if an object with extremely high luminance is just outside the meter's measuring area.

The graph at right shows the effect when a bright point is moved from A inside the measuring area to B just outside the measuring area.

If the measured value at A is defined at 100%, the measured value at B would be less than 0.1%.

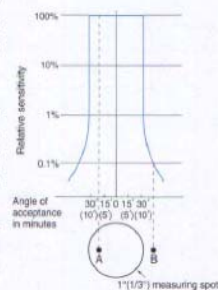


Fig. F-6. Luminance meter LS-100 by Konica-Minolta.

Table F-2  
Specifications for Konica-Minolta LS-100 luminance meter

### SPECIFICATIONS

Model	Luminance Meter LS-100	Luminance Meter LS-110
Type	SLR spot luminance meter for measuring light-source and surface brightness	
Acceptance angle	1°	1/3°
Optical system	85mm f/2.8 lens; SLR viewing system; flare factor less than 1.5%	
Angle of view	9°	
Focusing distance	1014mm (40 in.) to infinity	
Minimum measuring area	ø14.4mm	ø4.8mm
Receptor	Silicon photodiode	
Relative Spectral Response*	Within 8% (f1) of the CIE spectral luminous efficiency V (λ)	
Response time	FAST: Sampling time: 0.1s, time to display: 0.8 to 1.0s; SLOW: Sampling time: 0.4s, time to display: 1.4 to 1.6s	
Luminance units	cd/m <sup>2</sup> or fL (switchable)	
Measuring range	FAST: 0.001 to 299,900cd/m <sup>2</sup> (0.001 to 87,530fL) SLOW: 0.001 to 49,990cd/m <sup>2</sup> (0.001 to 14,590fL)	FAST: 0.01 to 999,900cd/m <sup>2</sup> (0.01 to 291,800fL) SLOW: 0.01 to 499,900cd/m <sup>2</sup> (0.01 to 145,900fL)
Accuracy	0.001 to 0.999cd/m <sup>2</sup> (or fL): ±2% ±2 digits of displayed value 1.000cd/m <sup>2</sup> (or fL) or greater: ±2% ±1 digit of displayed value (Illuminant A measured at ambient temperature of 20 to 30°C/68 to 86°F)	0.01 to 9.99cd/m <sup>2</sup> (or fL): ±2% ±2 digits of displayed value 10.00cd/m <sup>2</sup> (or fL) or greater: ±2% ±1 digit of displayed value
Repeatability	0.001 to 0.999cd/m <sup>2</sup> (or fL): ±0.2% ±2 digits of displayed value 1.000cd/m <sup>2</sup> (or fL) or greater: ±0.2% ±1 digit of displayed value (Measurement subject: Illuminant A)	0.01 to 9.99cd/m <sup>2</sup> (or fL): ±0.2% ±2 digits of displayed value 10.00cd/m <sup>2</sup> (or fL) or greater: ±0.2% ±1 digit of displayed value
Temperature/humidity drift	Within ±3% ±1 digit (of value displayed at 20°C/68°F) within operating temperature/humidity range	
Calibration mode	Minolta standard/user-selected standard (switchable)	
Color correction factor	Set by numerical input; range: 0.001 to 9.999	
Reference luminance	1; set by measurement or numerical input	
Measurement modes	Luminance; luminance ratio; peak luminance or luminance ratio	
Display	External: 4-digit LCD with additional indications Viewfinder: 4-digit LCD with LED backlight	
Data communication	RS-232C; baud rate: 4800bps	
External control	Measurement process can be started by external device connected to data output terminal	
Power source	One 9V battery; power can also be supplied by optional Data Printer DP-10	
Power consumption	While measuring button is pressed and viewfinder display is lit: 16mA average While power is on and viewfinder display is not lit: 6mA average	
Operating environment conditions	Temperature: 0 to 40°C (32 to 104°F); relative humidity 85% or less (at 35°C/95°F) with no condensation, Maximum altitude: 2000m, Installation category: II, Pollution degree: 2	
Storage temperature range	-20 to 55°C (-4 to 131°F); relative humidity 85% or less (at 35°C/95°F) with no condensation	
Dimensions	79x208x150mm (3-1/8x8-3/16x5-7/8 in.)	
Weight	850g (30 oz.) without battery	
Standard accessories	Lens cap; Eyepiece cap; ND eyepiece filter; 9V battery; Case	

\* Equivalent to 2% specified for T-1 series.  
8% CIE(f1), new JIS(1993)  
2% old JIS

Specifications are subject to change without notice.



Fig. F-7. Nikon Coolpix 5400 used for photographic documentation.

# Nikon Coolpix 5400

## Digital Camera Specifications

<b>Type of camera</b>	Digital Camera ES400																																			
<b>Effective pixels</b>	5.1 million																																			
<b>CCD</b>	1/1.8-inch-type (total pixels: 5.26 million)																																			
<b>Image Size</b>	5M (2,592 x 1,944), 2M (1,600 x 1,200), 1M (1,280 x 960), PC (1,024 x 768), TV (640 x 480), 3:2 (2,592 x 1,728), user selectable																																			
<b>Lens</b>	4x Zoom-Nikkor; 1:5.8-24mm (35mm format equivalent to 28mm-116mm) /F2.8-4.6 with macro; 9 elements in 8 groups (one ED lens and two aspherical lenses are used); all elements are made of environmentally friendly glass; Nikon Super Integrated Coating (SIC) applied																																			
<b>Digital Zoom</b>	up to 4x (stepless)																																			
<b>Autofocus</b>	Contrast-detect TTLAF; 5-area MultiAF or Spot AF selectable																																			
<b>Focus modes</b>	1) Continuous AF mode (when using the LCD monitor) 2) Single AF (when not using the LCD monitor and/or selectable from shooting menu) 3) Manual Focus (from 0.4 in. (1cm) to infinity with focus confirmation indication)																																			
<b>Optical viewfinder</b>	Real-image zoom viewfinder; Diopter adjustment: -3 - +1m <sup>-1</sup>																																			
<b>LCD Monitor</b>	1.5-inch type, 134,000-dot highly transmissible advanced TFT-LCD (white LED backlight); brightness/lue adjustment; frame coverage: approx. 97%																																			
<b>Storage</b>	System: EXIF 2.2 file (uncompressed TIFF-RGB or compressed JPEG) Design rule for camera file system (DCF); Digital Print Order Format (DPOF); QuickTime Motion JPEG (Movie, Audio) Media: CompactFlash™ Card Type I/II, 512MB/1GB Microdrive™ Card																																			
<b>Shooting modes</b>	Auto, Scene, P, S, A, M, Movie																																			
<b>Number of frames with 16MB Starter Memory Card (approx.)</b>	<table border="1"> <thead> <tr> <th>Image size</th> <th>5M</th> <th>2M</th> <th>1M</th> <th>PC</th> <th>TV</th> <th>3:2</th> </tr> </thead> <tbody> <tr> <td>HI</td> <td>1</td> <td>-</td> <td>-</td> <td>-</td> <td>-</td> <td>1</td> </tr> <tr> <td>FINE</td> <td>6</td> <td>15</td> <td>24</td> <td>37</td> <td>96</td> <td>7</td> </tr> <tr> <td>NORMAL</td> <td>12</td> <td>31</td> <td>47</td> <td>69</td> <td>144</td> <td>14</td> </tr> <tr> <td>BASIC</td> <td>24</td> <td>59</td> <td>86</td> <td>121</td> <td>229</td> <td>27</td> </tr> </tbody> </table>	Image size	5M	2M	1M	PC	TV	3:2	HI	1	-	-	-	-	1	FINE	6	15	24	37	96	7	NORMAL	12	31	47	69	144	14	BASIC	24	59	86	121	229	27
Image size	5M	2M	1M	PC	TV	3:2																														
HI	1	-	-	-	-	1																														
FINE	6	15	24	37	96	7																														
NORMAL	12	31	47	69	144	14																														
BASIC	24	59	86	121	229	27																														
<b>Scene Modes</b>	Portrait, Party/Indoor, Night Portrait, Beach/Snow, Landscape, Sunset, Night Landscape, Museum, Fireworks Show, Close Up, Copy, Back Light, Sports, Panorama Assist, and Dawn/Dusk																																			
<b>User setting</b>	1) White Balance, 2) (Exposure) Metering, 3) Continuous (Shooting), 4) Best Shot Selector (BSS/AE-BSS), 5) Image adjustment (Auto/Normal/More Contrast/Less Contrast), 6) Saturation control (-2 - +2/Black and White), 7) User setting (two combinations of mode setting can be memorized in #1-#2), 8) Image quality/size, 9) Sensitivity, 10) Image Sharpening, 11) Lens, 12) Exposure options (AE Lock, Maximum Bulb/Time duration), 13) Focus options, 14) Zoom options, 15) Speedlight options, 16) Auto bracketing, 17) Noise reduction, 18) Reset, 19) My menu, 20) CF card format																																			
<b>Capture modes</b>	1) Single, 2) Continuous H (3 fps; up to 7 frames), 3) Continuous L (1.5 fps; up to 18 frames), 4) Multi-Shot 16 (consecutive 16 frames at 2 fps), 5) Ultra High-speed continuous (OVGA-size images; 30 fps; number of frames selectable; up to 100 frames), 6) Five Shot Buffer (1.5 fps), 7) Movie with audio; TV movie mode (VGA-size images; 640 x 400 pixels) at 15 fps; up to 70 sec., or Small Movie (OVGA-size images; 320 x 240 pixels) at 15 fps; up to 180 sec., are selectable, 8) Time Lapse Movie																																			
<b>Exposure metering</b>	4-mode TTL metering: 1) 256-segment Matrix, 2) Center-weighted, 3) Spot, 4) AF Spot																																			
<b>Exposure control</b>	1) Programmed Auto with Flexible Program (P), 2) Shutter-Priority Auto (S), 3) Aperture-Priority Auto (A), 4) Manual (M); Exposure compensation (+/- 2 EV in 1/3 EV steps); Auto Exposure Bracketing (3 or 5 frames within +/- 2 EV); AE-BSS (three modes; Highlight, Shadow, Histogram)																																			
<b>Exposure range</b>	EV -10 - +18(W), EV +0.5 - +18(T)																																			
<b>Shutter</b>	Mechanical and charge-coupled electronic shutter: 1/4,000 (with minimum aperture) to 1 sec. In AUTO mode and Programmed Auto (P); 1/4,000 to 8 sec. In Shutter-Priority Auto (S) and Aperture-Priority Auto (A), 1/4,000 to 8 sec., and Bulb/Time limit (up to 10 minutes) in Manual (M), 1/8,000 to 1/30 sec. In Ultra High-speed continuous mode																																			
<b>Aperture</b>	6-blade iris diaphragm; 10 steps in 1/3 EV increments																																			
<b>Sensitivity (approx)</b>	ISO 50 equivalent; 100, 200, 400 and Auto (can be controlled in any exposure mode)																																			
<b>White Balance</b>	1) Matrix Auto White Balance with TTL control, 2) 6-mode Manual with fine tuning (Daylight/Incandescent/Fluorescent/Cloudy/Speedlight/Shade), 3) Preset, 4) White Balance Bracketing																																			
<b>Self timer</b>	10 sec. or 3 sec. duration																																			
<b>Built-in speedlight</b>	Shooting range: approx. 1.6 - 14.8 ft (0.5 - 4.5m) (W), approx. 1.6 - 9.2 ft (0.5 - 2.8m) (T), Flash Modes: 1) Auto Flash, 2) Flash Cancel, 3) Redeye reduction, 4) Anytime flash, 5) Slow sync flash, 6) Rear curtain sync; Repeating flash																																			
<b>Accessory shoe</b>	Standard ISO 518; lock pin provided prevents Nikon speedlight from slipping off																																			
<b>External speedlight</b>	Hotshoe connects to external Nikon Speedlight SB-600/800X/500X/30/27/23/22s (must set speedlight control to Auto or internal off when using an SB-27 or SB-23); built-in Speedlight can be canceled when using external Speedlight(s)																																			
<b>Playback menu options</b>	1) 1 frame, 2) Thumbnail (4/9 segments), 3) Slide show, 4) Movie with audio, 5) Enlarged playback (up to 6x); Shooting information; Histogram indication and highlight point display; Hide and protect attributes can be set to each image; Focus confirmation indication																																			
<b>Interface</b>	USB interface (mass storage/PTP)																																			
<b>I/O terminal</b>	Power input; Audio/video output (NTSC or PAL selectable); Digital port (USB/Remote Cord)																																			
<b>Power requirements</b>	One rechargeable Li-ion battery EN-EL1 (included), one 6V 2CR5/DL245 Lithium battery (optional), EH-53 AC adapter (optional)																																			
<b>Battery life</b>	Approx. 110 min. when using LCD monitor and EN-EL1 battery at normal temperature (68°F/20°C)																																			
<b>Dimensions (W x H x D)</b>	4.3 x 2.9 x 2.7 in. (108 x 73 x 68mm)																																			
<b>Weight (without battery)</b>	Approx. 11.3 oz. (320g) (without battery and storage media)																																			
<b>Accessories (included)</b>	Lens cap, Camera strap, Audio Video Cable, Nikon Coolpix Starter Memory Card, UC-E1 USB cable, EN-EL1 Rechargeable Li-ion battery, MH-53 battery charger, NikonView CD-ROM (please note, standard accessories may differ by country or area)																																			
<b>Optional accessories</b>	FC-E9 Fisheye Converter Lens, WC-E80 Wideangle Converter Lens, TC-E15ED Telephoto Converter Lens, ES-E28 Slide Copy Adapter (recommended for use with 1.1x digital zoom or higher), Converter Adapters UR-E9, UR-E10, and UR-E11, HN-CP10 Lens Hood, EH-53 AC Adapter, MH-53C Car Battery Charger (12V DC in), MC-EU1 Remote Cord, Camera Case																																			
<b>NikonView 6 System requirements for Macintosh</b>	OS: Mac® OS 9.0 - 9.2 (only built-in USB ports supported), Mac® OS X (10.1.3 or later) Models: iMac®, iMac® DV, Power Macintosh® G3 (Blue & White), Power Mac® G4 or later; iBook®, PowerBook® G3 or later (only built-in USB ports supported) RAM: 64MB or more recommended Hard disk: 60MB required for installation, with additional amount equivalent to twice the capacity of the camera memory card plus 10MB required when NikonView 6 is running Display: 800 x 600 with 16-bit colors (full color recommended) Others: CD-ROM drive required for installation																																			
<b>NikonView 6 System requirements for PC</b>	OS: Windows® 98SE, Windows® Me, Windows® 2000 Professional, Windows® XP Home Edition, Windows® XP Professional pre-installed model Models: Only models with built-in USB ports supported CPU: 300MHz® Pentium® or faster RAM: 64MB or more recommended Hard disk: 60MB required for installation, with additional amount equivalent to twice the capacity of the camera memory card plus 10MB required when NikonView 6 is running Display: 800 x 600 with 16-bit colors (full color recommended) Others: CD-ROM drive required for installation																																			
<b>Product Number:</b>	25513 UPC code: 018208255139																																			

Additional accessories can be found at  
[www.nikoncoolpix.com](http://www.nikoncoolpix.com) on the Coolpix 5400 page



All products indicated by trademark symbols are trademarked and/or registered by their respective companies. Specifications and equipment are subject to change without any notice or obligation on the part of the manufacturer. 09/03

©2003 NIKON INC.

Nikon Inc.,  
 1300 Walt Whitman Road, Melville, NY 11747  
[www.nikonusa.com](http://www.nikonusa.com) / 1-800-Nikon-UX

CDP-5400-01

If the picture matters the camera matters™ **Nikon**

Fig. F-8. Specifications for the Nikon Coolpix 5400.

**APPENDIX G**

**CALIBRATION OF PHOTOMETRIC SENSORS**

Table G-1  
Multipliers from Campbell SCI and from home calibration

New Sensors	Serial number	Name	Calibration Constant microamps per 100 Klux	Calibration Multiplier Klux per microamp	Multiplier from Campbell SCI	Calibration Date	Home Calibration Constant	Multiplier from daylight correction lux/mV	Multiplier from daylight and MINOLTA light meters correction lux/mV	Calibration Date
1	PH 7450	T-A1	33.43	-2.99	4952.53	4/27/2004	1.0034	4969.30	5043.84	10/27/2004
2	PH 7451	T-A2	34.85	-2.87	4750.73	4/27/2004	1.0059	4778.86	4850.54	10/27/2004
3	PH 7452	T-A3	35.6	-2.81	4650.64	4/27/2004	0.9988	4645.14	4714.82	10/27/2004
4	PH 7453	T-A4	32.99	-3.03	5018.58	4/27/2004	1.0087	5062.06	5137.99	10/27/2004
5	PH 7454	T-B1	33.68	-2.97	4915.76	4/27/2004	1.0066	4948.09	5022.31	10/27/2004
6	PH 7455	T-B2	34.05	-2.94	4862.35	4/27/2004	0.9995	4859.72	4932.61	10/27/2004
7	PH 7456	Ex-HG	32.78	-3.05	5050.73	4/27/2004	0.9951	5026.05	5312.54	10/27/2004
8	PH 7457	T-B3	34.26	-2.92	4832.54	4/27/2004	1.0025	4844.56	4917.23	10/27/2004
9	PH 7458	T-B4	31.66	-3.16	5229.40	4/27/2004	0.9935	5195.66	5273.60	10/27/2004
10	PH 7459	T-C1	35.19	-2.84	4704.83	4/27/2004	0.9988	4699.40	4769.89	10/27/2004
11	PH 7460	T-C2	32.84	-3.05	5041.50	4/27/2004	1.0097	5090.30	5166.65	10/27/2004
12	PH 7461	Ex-VG	34.13	-2.93	4850.95	4/27/2004	0.9994	4848.25	5124.60	10/27/2004
13	PH 7462	T-C3	33.96	-2.94	4875.23	4/27/2004	0.9942	4846.72	4919.43	10/27/2004
14	PH 7463	T-C4	32.8	-3.05	5047.65	4/27/2004	0.9964	5029.70	5105.15	10/27/2004
15	PH 7464	Ex-HD	33.24	-3.01	4980.83	4/27/2004	0.9967	4964.27	5247.24	10/27/2004
16	PH 7465	Ex-VD	33.84	-2.96	4892.52	4/27/2004	0.9980	4882.93	5161.25	10/27/2004
17	PH 7466	R-B1	31.09	-3.22	5325.28	4/27/2004	0.9912	5278.16	5357.33	10/27/2004
18	PH 7467	R-B2	33.67	-2.97	4917.22	4/27/2004	0.9969	4902.01	4975.54	10/27/2004
19	PH 7468	R-B3	31.75	-3.15	5214.58	4/27/2004	1.0056	5243.66	5322.32	10/27/2004
20	PH 7469	R-B4	32.09	-3.12	5159.33	4/27/2004	0.9961	5139.33	5216.42	10/27/2004

Old sensors										
21	PH 4157	R-A1	21.06	4.65	7861.49	8/1/1988	1.0381	8161.27	8283.69	10/27/2004
22	PH 4158	R-A2	20.04	4.99	8261.62	8/1/1988	1.0546	8712.80	8843.49	10/27/2004
23	PH 4159	R-A3	20.45	4.89	8095.99	8/1/1988	1.0385	8407.87	8533.99	10/27/2004
24	PH 4160	R-A4	19.79	5.05	8365.99	8/1/1988	1.1168	9342.77	9482.92	10/27/2004
25	PH 4161	R-C1	20.44	4.89	8099.95	8/1/1988	1.0871	8805.74	8937.82	10/27/2004
26	PH 4162	R-C2	20.63	4.85	8025.35	8/1/1988	1.0513	8437.11	8563.67	10/27/2004
27	PH 4163	R-C3	20.29	4.93	8159.83	8/1/1988	1.0291	8397.09	8523.05	10/27/2004
28	PH 4164	R-C4	19.33	5.17	8565.08	8/1/1988	1.0739	9198.16	9336.13	10/27/2004

**APPENDIX H**

**DATALOGGER'S PROGRAM**

The program to collect the data was written with SCWIN version 2.0 (Beta) in the first place, and later modified with LoggerNet version 2.1.0.15. Both programs are from Campbell Scientific, Inc.

## H.1. TIPS ABOUT THE PROCESS OF WRITING THE PROGRAM

### H.1.1. How to Set Sensors in the Program to Obtain Lux as Output

Table H-1

Step-by-step formulas to convert from calibration constant values to multiplier values

Formulas
<p><b>1) To pass from microamps to millivolts</b>  <math>(\text{CalibConst}[\mu\text{A}/100\text{KLux}] \times 604 \text{ Ohms}) / 1000 = X [\text{millivolts}/100\text{KLux}]</math></p>
<p><b>2) To pass from X mV/100KLux to Y Klux per each mV</b>  <math>100 \text{ Klux} / X \text{ mV} = Y \text{ Klux/mV}</math></p>
<p><b>2) To pass from Y KLux to Y lux per each mV</b>  <math>Y \text{ Klux/mV} \times 1000 = Y \text{ lux/mV}</math></p>

Note: The multipliers are used in the datalogger's program to convert the differential voltage the photometric sensors measure to illuminance values (lux)

### H.1.2. Out of Range Values. How to Avoid this Problem

When measuring illuminance values of 51000 lux and above, obtaining numbers like -99999 in the data collection is because the range of sensors voltage needs to be increased in the datalogger's program. In this study it was corrected from +/-10mV to +/- 50mV.

### H.1.3. High and Low Resolution

Low resolution is the default resolution and measures up to 6999. That may work well for interior measurements, but just in case, it was set to high resolution, which measures numbers up to 99999 lux. High resolution was set in line #95 with command P78. In line #125, measurement was set back to low resolution. Exterior illuminance values can go beyond 99999 lux; for that reason exterior measurements are expressed in Klux. This is set from the multiplier (see multipliers for exterior sensors in Table G-1).

## H.2. DATALOGGER'S PROGRAM

```

;{CR23X}
*Table 1 Program
  01: 60.0000 Execution Interval (seconds)

1: Batt Voltage (P10)
  1: 1   Loc [ Batt_Volt ]

2: If time is (P92)
  1: 0   Minutes (Seconds --) into a
  2: 1440 Interval (same units as above)
  3: 30   Then Do

3: Signature (P19)
  1: 2   Loc [ Prog_Sig ]

4: End (P95)

5: Do (P86)
  1: 41   Set Port 1 High

6: Do (P86)
  1: 72   Pulse Port 2

7: Delay w/Opt Excitation (P22)
  1: 1   Ex Channel
  2: 0   Delay W/Ex (0.01 sec units)
  3: 1   Delay After Ex (0.01 sec units)
  4: 0   mV Excitation

8: Volt (Diff) (P2)
  1: 1   Reps
  2: 22   50 mV, 60 Hz Reject, Slow Range
  3: 2   DIFF Channel
  4: 4   Loc [ T_A1 ]
  5: 5043.84 Mult
  6: 0.0   Offset

9: Do (P86)
  1: 72   Pulse Port 2

10: Delay w/Opt Excitation (P22)
  1: 1   Ex Channel
  2: 0   Delay W/Ex (0.01 sec units)
  3: 1   Delay After Ex (0.01 sec units)
  4: 0   mV Excitation

11: Volt (Diff) (P2)
  1: 1   Reps
  2: 22   50 mV, 60 Hz Reject, Slow Range
  3: 2   DIFF Channel

```



4: 5 Loc [ T\_A2 ]  
5: 4850.54 Mult  
6: 0.0 Offset

12: Do (P86)

1: 72 Pulse Port 2

13: Delay w/Opt Excitation (P22)

1: 1 Ex Channel  
2: 0 Delay W/Ex (0.01 sec units)  
3: 1 Delay After Ex (0.01 sec units)  
4: 0 mV Excitation

14: Volt (Diff) (P2)

1: 1 Repts  
2: 22 50 mV, 60 Hz Reject, Slow Range  
3: 2 DIFF Channel  
4: 6 Loc [ T\_A3 ]  
5: 4714.82 Mult  
6: 0.0 Offset

15: Do (P86)

1: 72 Pulse Port 2

16: Delay w/Opt Excitation (P22)

1: 1 Ex Channel  
2: 0 Delay W/Ex (0.01 sec units)  
3: 1 Delay After Ex (0.01 sec units)  
4: 0 mV Excitation

17: Volt (Diff) (P2)

1: 1 Repts  
2: 22 50 mV, 60 Hz Reject, Slow Range  
3: 2 DIFF Channel  
4: 7 Loc [ T\_A4 ]  
5: 5137.99 Mult  
6: 0.0 Offset

18: Do (P86)

1: 72 Pulse Port 2

19: Delay w/Opt Excitation (P22)

1: 1 Ex Channel  
2: 0 Delay W/Ex (0.01 sec units)  
3: 1 Delay After Ex (0.01 sec units)  
4: 0 mV Excitation

20: Volt (Diff) (P2)

1: 1 Repts  
2: 22 50 mV, 60 Hz Reject, Slow Range  
3: 2 DIFF Channel  
4: 8 Loc [ T\_B1 ]  
5: 5022.31 Mult

6: 0.0 Offset

21: Do (P86)

1: 72 Pulse Port 2

22: Delay w/Opt Excitation (P22)

1: 1 Ex Channel

2: 0 Delay W/Ex (0.01 sec units)

3: 1 Delay After Ex (0.01 sec units)

4: 0 mV Excitation

23: Volt (Diff) (P2)

1: 1 Repts

2: 22 50 mV, 60 Hz Reject, Slow Range

3: 2 DIFF Channel

4: 9 Loc [ T\_B2 ]

5: 4932.61 Mult

6: 0.0 Offset

24: Do (P86)

1: 72 Pulse Port 2

25: Delay w/Opt Excitation (P22)

1: 1 Ex Channel

2: 0 Delay W/Ex (0.01 sec units)

3: 1 Delay After Ex (0.01 sec units)

4: 0 mV Excitation

26: Volt (Diff) (P2)

1: 1 Repts

2: 22 50 mV, 60 Hz Reject, Slow Range

3: 2 DIFF Channel

4: 10 Loc [ T\_B3 ]

5: 4917.23 Mult

6: 0.0 Offset

27: Do (P86)

1: 72 Pulse Port 2

28: Delay w/Opt Excitation (P22)

1: 1 Ex Channel

2: 0 Delay W/Ex (0.01 sec units)

3: 1 Delay After Ex (0.01 sec units)

4: 0 mV Excitation

29: Volt (Diff) (P2)

1: 1 Repts

2: 22 50 mV, 60 Hz Reject, Slow Range

3: 2 DIFF Channel

4: 11 Loc [ T\_B4 ]

5: 5273.6 Mult

6: 0.0 Offset

30: Do (P86)

1: 72 Pulse Port 2

31: Delay w/Opt Excitation (P22)

1: 1 Ex Channel

2: 0 Delay W/Ex (0.01 sec units)

3: 1 Delay After Ex (0.01 sec units)

4: 0 mV Excitation

32: Volt (Diff) (P2)

1: 1 Reps

2: 22 50 mV, 60 Hz Reject, Slow Range

3: 2 DIFF Channel

4: 12 Loc [ T\_C1 ]

5: 4769.89 Mult

6: 0.0 Offset

33: Do (P86)

1: 72 Pulse Port 2

34: Delay w/Opt Excitation (P22)

1: 1 Ex Channel

2: 0 Delay W/Ex (0.01 sec units)

3: 1 Delay After Ex (0.01 sec units)

4: 0 mV Excitation

35: Volt (Diff) (P2)

1: 1 Reps

2: 22 50 mV, 60 Hz Reject, Slow Range

3: 2 DIFF Channel

4: 13 Loc [ T\_C2 ]

5: 5166.65 Mult

6: 0.0 Offset

36: Do (P86)

1: 72 Pulse Port 2

37: Delay w/Opt Excitation (P22)

1: 1 Ex Channel

2: 0 Delay W/Ex (0.01 sec units)

3: 1 Delay After Ex (0.01 sec units)

4: 0 mV Excitation

38: Volt (Diff) (P2)

1: 1 Reps

2: 22 50 mV, 60 Hz Reject, Slow Range

3: 2 DIFF Channel

4: 14 Loc [ T\_C3 ]

5: 4919.43 Mult

6: 0.0 Offset

39: Do (P86)

1: 72 Pulse Port 2

## 40: Delay w/Opt Excitation (P22)

1: 1 Ex Channel  
2: 0 Delay W/Ex (0.01 sec units)  
3: 1 Delay After Ex (0.01 sec units)  
4: 0 mV Excitation

## 41: Volt (Diff) (P2)

1: 1 Reps  
2: 22 50 mV, 60 Hz Reject, Slow Range  
3: 2 DIFF Channel  
4: 15 Loc [ T\_C4 ]  
5: 5105.15 Mult  
6: 0.0 Offset

## 42: Do (P86)

1: 72 Pulse Port 2

## 43: Delay w/Opt Excitation (P22)

1: 1 Ex Channel  
2: 0 Delay W/Ex (0.01 sec units)  
3: 1 Delay After Ex (0.01 sec units)  
4: 0 mV Excitation

## 44: Volt (Diff) (P2)

1: 1 Reps  
2: 22 50 mV, 60 Hz Reject, Slow Range  
3: 2 DIFF Channel  
4: 16 Loc [ R\_A1 ]  
5: 8283.69 Mult  
6: 0.0 Offset

## 45: Do (P86)

1: 72 Pulse Port 2

## 46: Delay w/Opt Excitation (P22)

1: 1 Ex Channel  
2: 0 Delay W/Ex (0.01 sec units)  
3: 1 Delay After Ex (0.01 sec units)  
4: 0 mV Excitation

## 47: Volt (Diff) (P2)

1: 1 Reps  
2: 22 50 mV, 60 Hz Reject, Slow Range  
3: 2 DIFF Channel  
4: 17 Loc [ R\_A2 ]  
5: 8843.49 Mult  
6: 0.0 Offset

## 48: Do (P86)

1: 72 Pulse Port 2

## 49: Delay w/Opt Excitation (P22)

1: 1 Ex Channel  
2: 0 Delay W/Ex (0.01 sec units)  
3: 1 Delay After Ex (0.01 sec units)  
4: 0 mV Excitation

## 50: Volt (Diff) (P2)

1: 1 Repts  
2: 22 50 mV, 60 Hz Reject, Slow Range  
3: 2 DIFF Channel  
4: 18 Loc [ R\_A3 ]  
5: 8533.99 Mult  
6: 0.0 Offset

## 51: Do (P86)

1: 72 Pulse Port 2

## 52: Delay w/Opt Excitation (P22)

1: 1 Ex Channel  
2: 0 Delay W/Ex (0.01 sec units)  
3: 1 Delay After Ex (0.01 sec units)  
4: 0 mV Excitation

## 53: Volt (Diff) (P2)

1: 1 Repts  
2: 22 50 mV, 60 Hz Reject, Slow Range  
3: 2 DIFF Channel  
4: 19 Loc [ R\_A4 ]  
5: 9482.92 Mult  
6: 0.0 Offset

## 54: Do (P86)

1: 72 Pulse Port 2

## 55: Delay w/Opt Excitation (P22)

1: 1 Ex Channel  
2: 0 Delay W/Ex (0.01 sec units)  
3: 1 Delay After Ex (0.01 sec units)  
4: 0 mV Excitation

## 56: Volt (Diff) (P2)

1: 1 Repts  
2: 22 50 mV, 60 Hz Reject, Slow Range  
3: 2 DIFF Channel  
4: 20 Loc [ R\_B1 ]  
5: 5357.33 Mult  
6: 0.0 Offset

## 57: Do (P86)

1: 72 Pulse Port 2

## 58: Delay w/Opt Excitation (P22)

1: 1 Ex Channel  
2: 0 Delay W/Ex (0.01 sec units)

3: 1 Delay After Ex (0.01 sec units)  
4: 0 mV Excitation

59: Volt (Diff) (P2)

1: 1 Repts  
2: 22 50 mV, 60 Hz Reject, Slow Range  
3: 2 DIFF Channel  
4: 21 Loc [ R\_B2 ]  
5: 4975.54 Mult  
6: 0.0 Offset

60: Do (P86)

1: 72 Pulse Port 2

61: Delay w/Opt Excitation (P22)

1: 1 Ex Channel  
2: 0 Delay W/Ex (0.01 sec units)  
3: 1 Delay After Ex (0.01 sec units)  
4: 0 mV Excitation

62: Volt (Diff) (P2)

1: 1 Repts  
2: 22 50 mV, 60 Hz Reject, Slow Range  
3: 2 DIFF Channel  
4: 22 Loc [ R\_B3 ]  
5: 5322.32 Mult  
6: 0.0 Offset

63: Do (P86)

1: 72 Pulse Port 2

64: Delay w/Opt Excitation (P22)

1: 1 Ex Channel  
2: 0 Delay W/Ex (0.01 sec units)  
3: 1 Delay After Ex (0.01 sec units)  
4: 0 mV Excitation

65: Volt (Diff) (P2)

1: 1 Repts  
2: 22 50 mV, 60 Hz Reject, Slow Range  
3: 2 DIFF Channel  
4: 23 Loc [ R\_B4 ]  
5: 5216.42 Mult  
6: 0.0 Offset

66: Do (P86)

1: 72 Pulse Port 2

67: Delay w/Opt Excitation (P22)

1: 1 Ex Channel  
2: 0 Delay W/Ex (0.01 sec units)  
3: 1 Delay After Ex (0.01 sec units)  
4: 0 mV Excitation

## 68: Volt (Diff) (P2)

1: 1 Reps  
2: 22 50 mV, 60 Hz Reject, Slow Range  
3: 2 DIFF Channel  
4: 24 Loc [ R\_C1 ]  
5: 8937.82 Mult  
6: 0.0 Offset

## 69: Do (P86)

1: 72 Pulse Port 2

## 70: Delay w/Opt Excitation (P22)

1: 1 Ex Channel  
2: 0 Delay W/Ex (0.01 sec units)  
3: 1 Delay After Ex (0.01 sec units)  
4: 0 mV Excitation

## 71: Volt (Diff) (P2)

1: 1 Reps  
2: 22 50 mV, 60 Hz Reject, Slow Range  
3: 2 DIFF Channel  
4: 25 Loc [ R\_C2 ]  
5: 8563.67 Mult  
6: 0.0 Offset

## 72: Do (P86)

1: 72 Pulse Port 2

## 73: Delay w/Opt Excitation (P22)

1: 1 Ex Channel  
2: 0 Delay W/Ex (0.01 sec units)  
3: 1 Delay After Ex (0.01 sec units)  
4: 0 mV Excitation

## 74: Volt (Diff) (P2)

1: 1 Reps  
2: 22 50 mV, 60 Hz Reject, Slow Range  
3: 2 DIFF Channel  
4: 26 Loc [ R\_C3 ]  
5: 8523.05 Mult  
6: 0.0 Offset

## 75: Do (P86)

1: 72 Pulse Port 2

## 76: Delay w/Opt Excitation (P22)

1: 1 Ex Channel  
2: 0 Delay W/Ex (0.01 sec units)  
3: 1 Delay After Ex (0.01 sec units)  
4: 0 mV Excitation

## 77: Volt (Diff) (P2)

1: 1 Reps  
2: 22 50 mV, 60 Hz Reject, Slow Range  
3: 2 DIFF Channel  
4: 27 Loc [ R\_C4 ]  
5: 9336.13 Mult  
6: 0.0 Offset

78: Do (P86)

1: 72 Pulse Port 2

79: Delay w/Opt Excitation (P22)

1: 1 Ex Channel  
2: 0 Delay W/Ex (0.01 sec units)  
3: 1 Delay After Ex (0.01 sec units)  
4: 0 mV Excitation

80: Volt (Diff) (P2)

1: 1 Reps  
2: 22 50 mV, 60 Hz Reject, Slow Range  
3: 2 DIFF Channel  
4: 28 Loc [ Ex\_HG\_klu ]  
5: 5.3125 Mult  
6: 0.0 Offset

81: Do (P86)

1: 72 Pulse Port 2

82: Delay w/Opt Excitation (P22)

1: 1 Ex Channel  
2: 0 Delay W/Ex (0.01 sec units)  
3: 1 Delay After Ex (0.01 sec units)  
4: 0 mV Excitation

83: Volt (Diff) (P2)

1: 1 Reps  
2: 22 50 mV, 60 Hz Reject, Slow Range  
3: 2 DIFF Channel  
4: 29 Loc [ Ex\_VG\_klu ]  
5: 5.1246 Mult  
6: 0.0 Offset

84: Do (P86)

1: 72 Pulse Port 2

85: Delay w/Opt Excitation (P22)

1: 1 Ex Channel  
2: 0 Delay W/Ex (0.01 sec units)  
3: 1 Delay After Ex (0.01 sec units)  
4: 0 mV Excitation

86: Volt (Diff) (P2)

1: 1 Reps  
2: 22 50 mV, 60 Hz Reject, Slow Range



3: 2 DIFF Channel  
 4: 30 Loc [ Ex\_HD\_klu ]  
 5: 5.2472 Mult  
 6: 0.0 Offset

87: Do (P86)  
 1: 72 Pulse Port 2

88: Delay w/Opt Excitation (P22)  
 1: 1 Ex Channel  
 2: 0 Delay W/Ex (0.01 sec units)  
 3: 1 Delay After Ex (0.01 sec units)  
 4: 0 mV Excitation

89: Volt (Diff) (P2)  
 1: 1 Reps  
 2: 22 50 mV, 60 Hz Reject, Slow Range  
 3: 2 DIFF Channel  
 4: 31 Loc [ Ex\_VD\_klu ]  
 5: 5.1613 Mult  
 6: 0.0 Offset

90: Do (P86)  
 1: 51 Set Port 1 Low

91: If time is (P92)  
 1: 0 Minutes (Seconds --) into a  
 2: 1 Interval (same units as above)  
 3: 10 Set Output Flag High (Flag 0)

92: Set Active Storage Area (P80)^3909  
 1: 1 Final Storage Area 1  
 2: 102 Array ID

93: Real Time (P77)^20377  
 1: 1220 Year,Day,Hour/Minute (midnight = 2400)

94: Minimum (P74)^24720  
 1: 1 Reps  
 2: 0 Value Only  
 3: 1 Loc [ Batt\_Volt ]

95: Resolution (P78)  
 1: 1 High Resolution

96: Sample (P70)^15482  
 1: 1 Reps  
 2: 2 Loc [ Prog\_Sig ]

97: Sample (P70)^4274  
 1: 1 Reps  
 2: 4 Loc [ T\_A1 ]

98: Sample (P70)^31603  
1: 1 Reps  
2: 5 Loc [ T\_A2 ]

99: Sample (P70)^4516  
1: 1 Reps  
2: 6 Loc [ T\_A3 ]

100: Sample (P70)^22214  
1: 1 Reps  
2: 7 Loc [ T\_A4 ]

101: Sample (P70)^9249  
1: 1 Reps  
2: 8 Loc [ T\_B1 ]

102: Sample (P70)^24911  
1: 1 Reps  
2: 9 Loc [ T\_B2 ]

103: Sample (P70)^11960  
1: 1 Reps  
2: 10 Loc [ T\_B3 ]

104: Sample (P70)^12548  
1: 1 Reps  
2: 11 Loc [ T\_B4 ]

105: Sample (P70)^9461  
1: 1 Reps  
2: 12 Loc [ T\_C1 ]

106: Sample (P70)^12395  
1: 1 Reps  
2: 13 Loc [ T\_C2 ]

107: Sample (P70)^9094  
1: 1 Reps  
2: 14 Loc [ T\_C3 ]

108: Sample (P70)^17191  
1: 1 Reps  
2: 15 Loc [ T\_C4 ]

109: Sample (P70)^7588  
1: 1 Reps  
2: 16 Loc [ R\_A1 ]

110: Sample (P70)^31409  
1: 1 Reps  
2: 17 Loc [ R\_A2 ]

111: Sample (P70)^32146

1: 1 Reps  
2: 18 Loc [ R\_A3 ]

112: Sample (P70)^13478  
1: 1 Reps  
2: 19 Loc [ R\_A4 ]

113: Sample (P70)^9913  
1: 1 Reps  
2: 20 Loc [ R\_B1 ]

114: Sample (P70)^15091  
1: 1 Reps  
2: 21 Loc [ R\_B2 ]

115: Sample (P70)^874  
1: 1 Reps  
2: 22 Loc [ R\_B3 ]

116: Sample (P70)^10379  
1: 1 Reps  
2: 23 Loc [ R\_B4 ]

117: Sample (P70)^6939  
1: 1 Reps  
2: 24 Loc [ R\_C1 ]

118: Sample (P70)^29251  
1: 1 Reps  
2: 25 Loc [ R\_C2 ]

119: Sample (P70)^16236  
1: 1 Reps  
2: 26 Loc [ R\_C3 ]

120: Sample (P70)^19359  
1: 1 Reps  
2: 27 Loc [ R\_C4 ]

121: Sample (P70)^5871  
1: 1 Reps  
2: 28 Loc [ Ex\_HG\_klu ]

122: Sample (P70)^14974  
1: 1 Reps  
2: 29 Loc [ Ex\_VG\_klu ]

123: Sample (P70)^21583  
1: 1 Reps  
2: 30 Loc [ Ex\_HD\_klu ]

124: Sample (P70)^21177  
1: 1 Reps

2: 31    Loc [ Ex\_VD\_klu ]

125: Resolution (P78)

1: 0    -- Low Resolution

\*Table 2 Program

01: 10.0000    Execution Interval (seconds)

1: Serial Out (P96)

1: 71    Destination Output

\*Table 3 Subroutines

End Program

**APPENDIX I**  
**SURVEY'S DOCUMENTATION**

## I.1. SURVEY'S INFORMATION SHEET

### *An Experimental Setup to Evaluate the Daylighting Performance of an Advanced Optical Light Pipe for Deep-Plan Office Buildings*

Thank you for participating in this study, “An experimental setup to evaluate the daylight performance of advanced daylighting optical systems in deep plan office buildings,” by answering the questions in the attached document. You have been selected to be a possible participant among a total of 15 people. The purpose of this study is to establish the effectiveness of advanced daylighting systems in addressing the following objectives: to increase daylight levels at the rear of deep rooms, to obtain a more uniform distribution of the light within the space, to control direct sunlight, and to reduce glare problems. This questionnaire will help to establish the effectiveness of these systems in addressing the purposes stated previously. It will also help to study possible users’ responses towards the future application of these systems in office buildings.

If you agree to be in this study, you will be asked to observe the interior of two scale models through a hatch open at the back of each one of them. Both models represent open-plan office modules. First, you will have to observe the base case, which has a regular window. Then, you will have to observe the second model, which will have the same type of window as the base case model, and an advanced daylighting system. After the observation, you will be asked to fill out a questionnaire regarding the situations in both scale models, and the performance of the advanced daylighting system into the second model. This questionnaire will take only 15-20 minutes of your time. You can omit answering any question that might make you feel uncomfortable. You are assured that your responses regarding this study will be kept confidential. You will not be required to disclose your name for this research, and if you have any questions regarding the procedures, the researcher will answer them promptly. There are no risks associated with this study.

Your participation in this research is voluntary. You are free to withdraw your consent and discontinue your participation in the research at any time. There are no benefits of participation, and no monetary compensations will be provided to you. You will not earn any class credits for participating in this research. Research records will be stored securely, and only the researcher will have access to the records.

Your decision whether or not to participate will not affect your current or future relations with Texas A&M University. You can contact Betina Martins Mogo (researcher) at (281) 345-8309, or Dr. Liliana Beltrán, Assistant Professor, College of Architecture, at (979) 845-6545, with any questions about this study.

This research study has been reviewed by the Institutional Review Board – Human Subjects in Research, Texas A&M University. For research-related problems or questions regarding subjects’ rights, you can contact the Institutional Review Board through Dr. Michael W. Buckley, Director of Research Compliance, Office of Vice President for Research, at (979) 845-8585 ([mwbuckley@tamu.edu](mailto:mwbuckley@tamu.edu)).

Signature of investigator: \_\_\_\_\_

Date: \_\_\_\_\_

## I.2. SURVEY'S QUESTIONNAIRE

*Questionnaire*

Date: \_\_\_/\_\_\_/\_\_\_

Time: \_\_\_\_:\_\_\_\_

*The purpose of this study*

*The purpose of this study is to establish the effectiveness of advanced daylighting systems in addressing the following objectives: to increase daylight levels at the rear of deep rooms, to obtain a more uniform distribution of the light within the space, to control direct sunlight, and to reduce glare problems. This questionnaire will help to establish the effectiveness of these systems in addressing the purposes stated previously. It will also help to study possible users' responses towards the future application of these systems in office buildings.*

*Instructions: Please put a check mark against the option you have selected*

*Personal*

*The following information is needed for data analysis only. It will not be used to identify any individual respondent.*

*1. Gender*

*Female* \_\_\_      *Male* \_\_\_

*2. Age group*

*19-24* \_\_\_      *25-34* \_\_\_      *35-44* \_\_\_      *45-54* \_\_\_      *55-65* \_\_\_      *66-80* \_\_\_

*3. Level of Education (mark all that apply)*

*High School* \_\_\_      *Bachelor* \_\_\_      *Master* \_\_\_      *Doctorate* \_\_\_

*4. Occupation (mark all that apply)*

*Student* \_\_\_      *Faculty* \_\_\_      *Staff* \_\_\_      *Other* \_\_\_

*5. What type of workspace do you currently occupy most of the time?*

*A classroom*

*A computer lab*

*An enclosed, private office*

*An enclosed office shared with others*

*A workstation with lighter partitions*

*An office without partitions*

*Other (please specify)*

*6. Do you have daylight availability in this space?*

*Yes* \_\_\_      *No* \_\_\_

*7. Do you like to work in an environment with:*

*Daylight only*

*Electric light only*

*A combination of daylight and electric light*

*Daylighting System assessment*

*8. What is your impression, at first glance, of the overall lighting conditions in both models?*

*MODEL 1*      *Satisfactory* \_\_\_      *Too Dim (dark)* \_\_\_      *Too Bright* \_\_\_

*MODEL 2*      *Satisfactory* \_\_\_      *Too Dim (dark)* \_\_\_      *Too Bright* \_\_\_

9. How much would you like to work in an office space like:

MODEL 1 Very much\_\_\_ Moderately\_\_\_ A little\_\_\_ Not at all\_\_\_  
 MODEL 2 Very much\_\_\_ Moderately\_\_\_ A little\_\_\_ Not at all\_\_\_

10. Do you think you would need to turn on the electric lights in:







MODEL 1 Yes\_\_\_ No\_\_\_  
 MODEL 2 Yes\_\_\_ No\_\_\_

11. If the previous answer was "Yes" for either model or for both models, please say where you would illuminate with electric light.

MODEL 1 at the Back\_\_\_ at the Front\_\_\_ on the Right side\*\_\_\_ on the Left side\*  
 \_\_\_\_\_  
 MODEL 2 at the Back\_\_\_ at the Front\_\_\_ on the Right side\*\_\_\_ on the Left side\*  
 \_\_\_\_\_

\*considered Right and Left as seen from the back of the models.

12. In which part of the room would you prefer to sit if you were working in:

MODEL 1	MODEL 2
 Half space next to the window ___	 Half space next to the window ___
 Half space next to the back ___	 Half space next to the back ___
 Anywhere. Doesn't matter ___	 Anywhere. Doesn't matter ___

13. Please explain why, in question #11, you selected that particular place in each of the models:

MODEL 1 \_\_\_\_\_  
 MODEL 2 \_\_\_\_\_

14. Do you think that there is too much light in some areas and not enough in others? Where?

MODEL 1 Yes\_\_\_ (if Yes, please say where)\_\_\_\_\_ No\_\_\_  
 MODEL 2 Yes\_\_\_ (if Yes, please say where)\_\_\_\_\_ No\_\_\_

15. Do you think that there are glare\* problems, enough to bother you, in the space of:

MODEL 1 Yes\_\_\_ (if Yes, please say where)\_\_\_\_\_ No\_\_\_  
 MODEL 2 Yes\_\_\_ (if Yes, please say where)\_\_\_\_\_ No\_\_\_

\*Glare is unwanted brightness viewed either directly or via reflection

16. Do you consider yourself as very sensitive to glare?

Yes\_\_\_ No\_\_\_

17. Do you wear some kind of glasses? Please specify all that apply

Sunglasses\_\_\_ Corrective glasses, near-sighted\_\_\_ Corrective glasses, far-sighted\_\_\_

18. Which one of the two models, in your opinion, has the most uniform daylight distribution?

MODEL 1\_\_\_ MODEL 2\_\_\_

19. In which of the two offices would you prefer to work?



MODEL 1\_\_\_\_

MODEL 2\_\_\_\_

20. Is there any suggestion that you would like to make to change the conditions in any of the models?

MODEL 1

No, I would leave it as it is\_\_\_\_

Yes\_\_\_\_(please explain)\_\_\_\_\_

MODEL 2

No, I would leave it as it is\_\_\_\_

Yes\_\_\_\_(please explain)\_\_\_\_\_

Thank you for completing the questionnaire.

**APPENDIX J****CORRECTION FACTOR OF CLOSED BLINDS TRANSMITTANCE  
FOR CLEAR DAYS**

### J.1. CORRECTION FACTOR FOR SUNNY DAYS

The experiment consisted of two instances. The first instance simulated the blinds semi-opened (one layer of white paper), and the second instance considered blinds closed (three layers of white paper). Most of the analysis was done considering closed blinds, which is a more realistic situation in open-plan offices. In order to use the data collected in the first instance, a correction factor was applied.

The procedure for obtaining this correction factor was to set both models as reference cases (without light pipe system), one having opened blinds and the other having closed blinds. First, the factor between two sensors was calculated, one in each model at the same position (Figure J-2). Since it appeared to be a linear function, a more precise factor was calculated taking the averaged values in each model (Figure J-4). Abnormalities in the linear function, briefly explained in Figure J-4, were fixed in Figure J-5, given the final correction factor with a value of 0.4076.

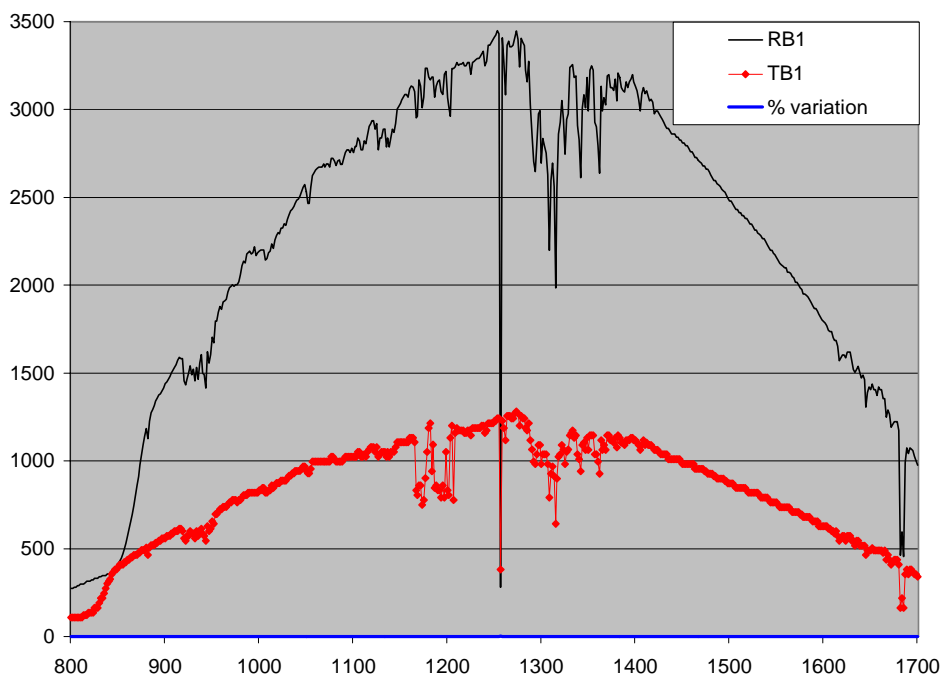


Fig. J-1. Comparison of sensors RB1 and TB1, the first in model with opened blinds and the second in model with closed blinds.

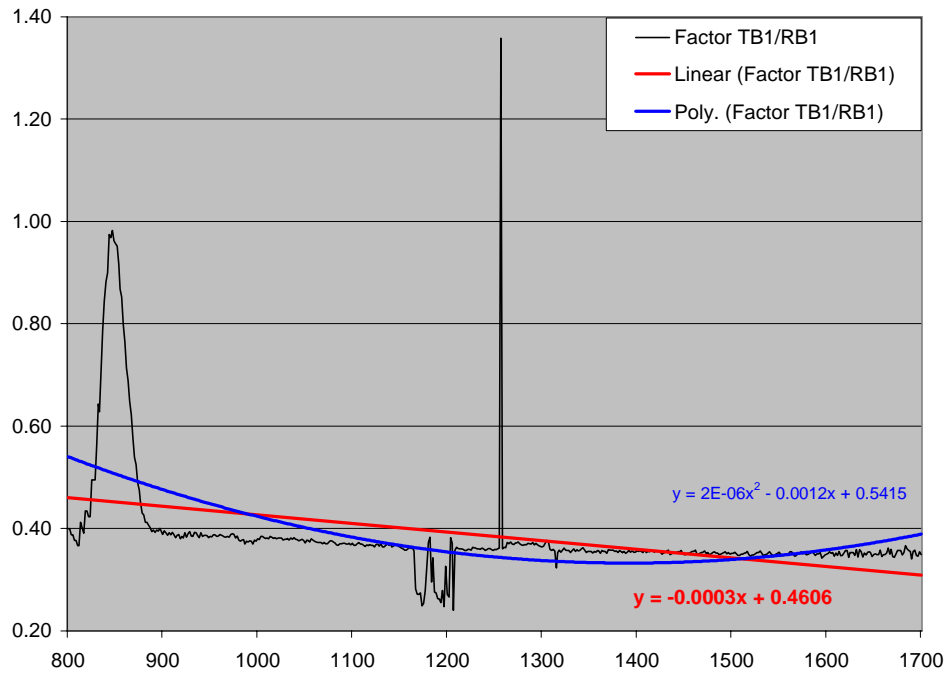


Fig. J-2. Factor TB1/RB1.

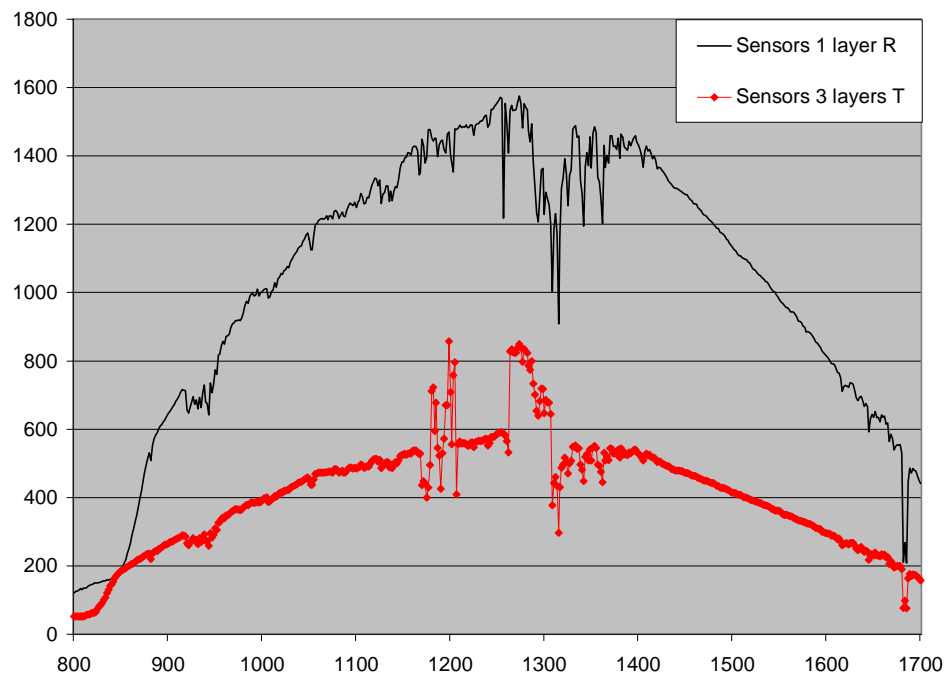


Fig. J-3. Averaged sensors "R" (1 layer) and "T" (3 layers).

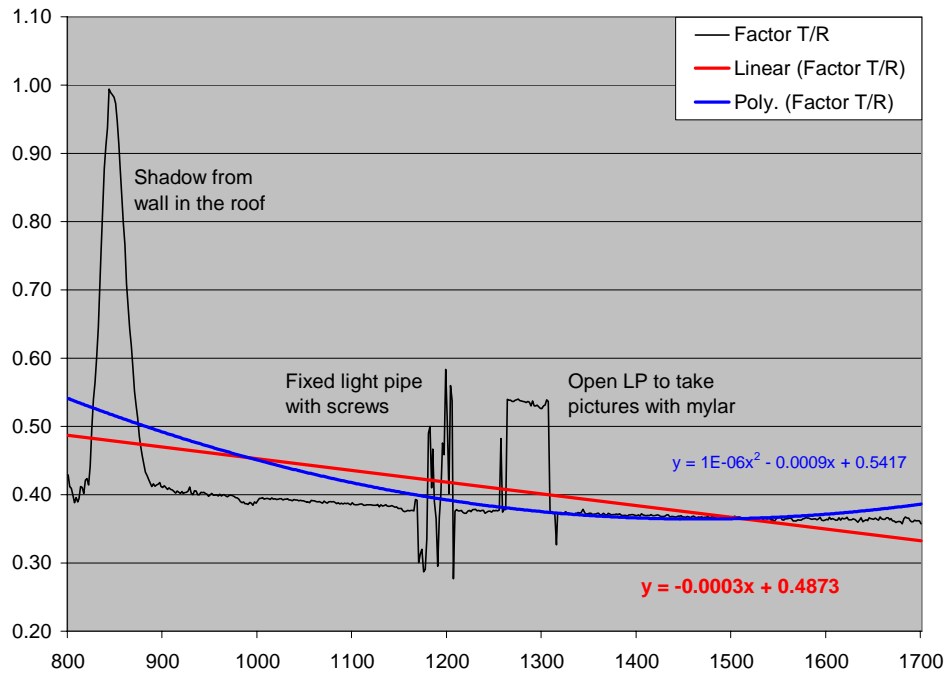


Fig. J-4. Factor of averaged sensors “R” (1 layer) and “T” (3 layers).

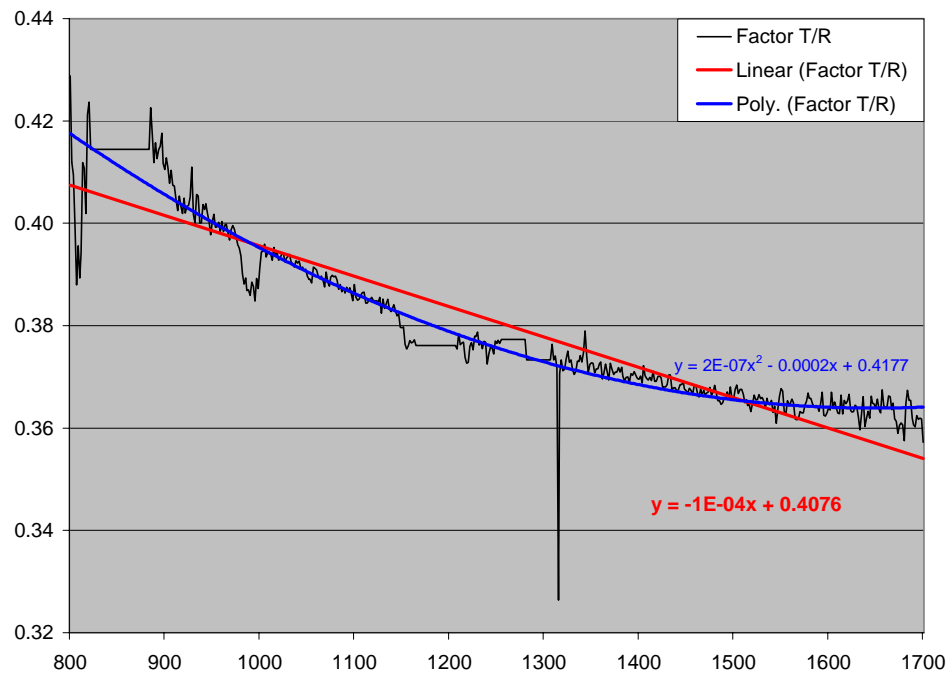


Fig. J-5. Factor of averaged sensors “R” (1 layer) and “T” (3 layers) after correction of abnormalities.

## VITA

Betina Gisela Martins Mogo de Nadal  
489 Pte. Perón  
Paraná, ER, 3100, Argentina  
betinamm@hotmail.com

### EDUCATION

M.S. in Architecture, Texas A&M University, College Station, TX, 2005. GPR 3.89  
Dip. in Architecture (6 yrs), Universidad Nacional de Rosario, SF, Argentina. 1989-1995

### MAJOR FIELD OF SPECIALIZATION

Daylighting, Energy Optimization in Building Design, Environmental Systems, Tools for Green Building Design.

### PROFESSIONAL EXPERIENCE

School of Architecture, Universidad Nacional de Rosario. Teaching Associate. Rosario, Argentina, 1998-2001.  
Freelance Architect. Rosario, Argentina, 1999-2001.  
Gerschfeld & Arjol Architects. Intermediate Production Coordinator and Design Architect. Rosario, Argentina, 1999.  
Kearney & Masera Architects. Junior Drafter/designer. Rosario, Argentina, 1996-1998.

### HONORS AND LEADERSHIP

Fulbright-Laspau Scholarship. Paid degree studies in United States for Master Degree from 2003-2005.  
President of IESNA Student Chapter at TAMU for the 2003-2004 academic year.  
James E. Wilson '55 Endowed Scholarship from the Department of Architecture Scholarships and Awards Committee at TAMU for the 2003-2004 academic year.

### PUBLICATIONS

Atre, U., Beltran, L., Chongcharoensuk, Ch., Martins-Mogo, B., 2004. Evaluating the Daylighting Performance of Three Museum Galleries. In: Proceedings of ASES 2004, Portland, OR.  
Beltran, L., Martins-Mogo, B., 2005. Assessment of Luminance Distribution Using HDR Photography. Accepted for presentation at ISES 2005 Solar World Conference, Orlando, Florida, August 2005.