

24-26 MAY 2022
SHORT COURSES: 23 MAY 2022
KUALA LUMPUR, MALAYSIA

PNEUMATICALLY ACTUATED CONTROL VALVES IN OIL SYSTEMS: HARDWARE RECOMMENDATIONS AND TUNING CONSIDERATIONS

Alex Schaefer

Technical Service Engineer
Elliott Company
Jeannette, PA, USA

Brian Pettinato

Manager, Aero and Structural Dynamics
Elliott Company
Jeannette, PA, USA



Alex Schaefer is a Technical Service Engineer at Elliott Company's headquarters facility located in Jeannette, Pennsylvania and has served on both API 614 and 692 task force committees. He started with Elliott 22 years ago as a Test Engineer at the Lubrication Systems Division in Donora, Pennsylvania supporting Elliott's design, manufacture, and testing of auxiliary systems for turbomachinery. He earned his B. S. degree in Mechanical Engineering from the University of Pittsburgh in 1991 and has been a Professional Engineer licensed in the State of Pennsylvania since 2001.



Brian Pettinato is Manager of the R&D Aero and Structural Dynamics Department at Elliott Group in Jeannette, Pennsylvania. He has been with Elliott Group since 1995. His primary area of expertise is machinery dynamics. Prior to joining Elliott Group, he worked as a project engineer for CentriMarc. Mr. Pettinato received his B.S. (1989) and M.S. (1992) Mechanical Engineering degrees from the University of Virginia. He has coauthored over thirty technical papers and holds three U.S. patents. Mr. Pettinato is a fellow member of ASME, a member of STLE, and a registered Professional Engineer in the State of Pennsylvania. He serves on the Turbomachinery Advisory Committee of Texas A&M and on the API 684 rotor dynamics task force.

ABSTRACT

Well designed and properly commissioned auxiliary systems are crucial to the reliability of rotating equipment. This paper addresses the upfront hardware selection and commissioning of pneumatically actuated control valves when applied in oil systems. Either improper selection and tuning of these valves or improper system design can cause poor reliability of the oil system resulting in spurious trips that can adversely impact turbomachinery and plant operation. Common problems are addressed.

INTRODUCTION

Pneumatically actuated control valves are typically the best choice in the following lube system applications:

- Temperature control
- Differential pressure control
- High flow or high pressure drop
- Lower ambient temperature environments
- Upgrades to existing systems

Hydraulically actuated control valves such as self-contained "regulators" or sliding-stem type globe valves with an external sensing line connecting the process directly to the actuator are generally limited in these applications due to a narrow range of capabilities. Existing plant specifications often require pneumatically actuated valves controlled by a Digital Control System (DCS).

BRIEF REVIEW OF CONTROL LOOPS

A control loop would not be needed if there were no disturbances in the process. With respect to pneumatically actuated control valves in oil systems, control loops are necessary to provide feedback control to hold or return the process variable to the set point when upsets occur. Delays anywhere in the control system can cause serious problems and must be managed to achieve good control.

Architecture

ISA 5.1, Instrumentation Symbols and Identification, 3.1.40 defines a control loop as:

“instrumentation arranged as a combination of two or more instruments or *functions* arranged so that signals pass from one to another for the purpose of *measurement* and indication or control of a *process variable*.”

Figure 1 shows a typical example of a control loop. The process flow measured at transmitter FT-01 produces an analog measurement signal sent to controller FRC-01 which compares the measurement to the process set point. FRC-01, then adjusts its output signal to control valve FV-01 thereby maintaining the set point.

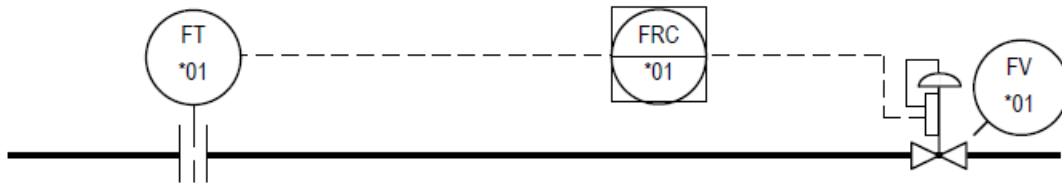

Figure 1. Typical flow control loop (Courtesy of ISA 5.1, B.9.3)

The difference (error) between the signal from FT-01 and the set point at FRC-01 determines not only the direction, but also the magnitude of change in the control signal to FV-01. The greater the error, the greater the magnitude of change in control signal to FV-01. If the magnitude in control signal change is too large, the process will overshoot the set point. This is typically referred to as “ringing” and the system is considered *under damped*. If the magnitude in control signal is less than optimal, the process will take longer than necessary to reach set point and the system is considered *over damped*. A well-tuned system, known as *critically damped* will reach the process set point as fast as possible without overshoot. Figure 2 illustrates these three types of systems.

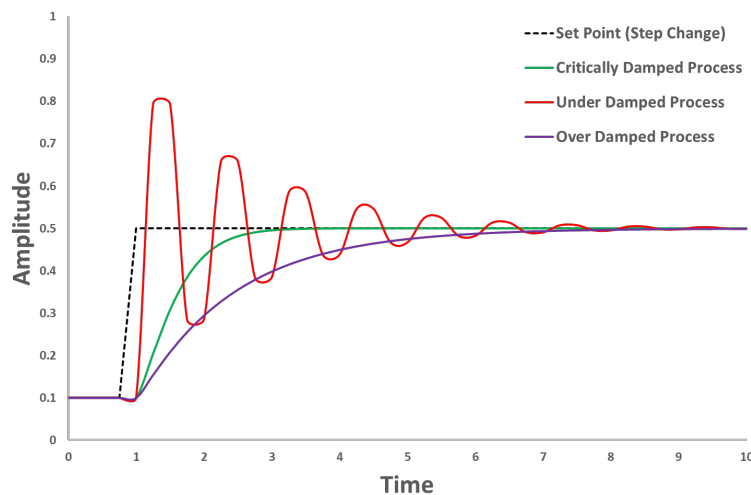

Figure 2. Damping in response to error between process and set point

Tuning

The controller FRC-01 in Figure 1 has adjustable parameters referred to as Proportion (P), Integral (I), and Derivative (D). During commissioning, these parameter values must be tuned so that the process reaches its set point quickly without causing excessive “ringing”. Tuning controllers to perform as a critically damped system can be very challenging since the optimum choice for each of these terms is dependent on the other two. This is why manual tuning can be considered an art, requiring experience and sometimes luck to optimize the combination of P, I, and D values.

The DCS software in which these controllers exist typically include an “autotuner” function that can take hours in the case of temperature control and may not yield the most optimal results. Operators should only take an autotuner’s results as a starting point that requires further refinement by traditional trial-and-error tuning techniques.

Another DCS software function typically available is self-adaptive tuning, which remains enabled while in service. Other than temperature control, this feature is generally unsuitable for oil system control loops because the self-adaptive tuning function can be “fooled” into making the tuning parameters too sluggish for transient disturbances such as pump upsets or servo valve transients. This could potentially cause equipment shutdown due to poor performance.

One last word concerning DCS software: like any other computer, the plant DCS is executing a programmed list of instructions, one at a time. The speed at which the DCS can update a given control loop is referred to as its “scan rate”. A scan rate of about 100 milliseconds or less is required for satisfactory tuning of all oil system control loops other than the temperature control loop.

SELECTION OF CONTROL LOOP HARDWARE

Thoughtful selection of the field devices and other hardware controlling a process ensures successful commissioning and trouble free service. Neglecting to correctly specify transmitters, control valve trim, and actuator accessories can lead to frustrating delays in commissioning (best case) and expensive maintenance issues later once in service. Including an accumulator as a last line of defense is not only cheap insurance, but is likely necessary to achieve acceptable performance.

Electronic Transmitters

Process variables used for control in an oil system are typically measured by electronic field devices and transmitted to the DCS as a 4 to 20 milliamp DC signal. The fidelity of this analog signal is a function of the transmitter total response time, which is typically 100 milliseconds. Note that digital output protocols such as Foundation Fieldbus have an even longer total response time.

Today’s “smart” transmitters typically include a configurable damping parameter for smoothing variations in output readings caused by rapid input changes, introducing an additional delay and increase in the response time of the transmitter. The factory default configuration for damping may be as low as 0.4 second, and as high as 3.2 seconds. Other than temperature control, reconfiguring this parameter to the minimum setting possible (hopefully zero) for oil system applications is necessary to obtain the best, or in most cases even acceptable tuning.

The configured measurement range of the transmitter must cover the entire operating range of the process, including abnormal conditions. For example, a transmitter measuring oil system pressure must be ranged to not only measure as high as the maximum allowable working pressure (MAWP), but also 10% above MAWP under brief, transient conditions. Note that today’s electronic transmitters have output signals that are linear across their entire measurement range. Their predecessors, Bourdon tube type instruments were only considered linear within the middle third of their full scale. Bourdon tube type instruments such as pneumatic transmitters have been seldom used since roughly 2000.

The location of a process variable measurement affects the performance of a control loop as well. Obviously, pressure & temperature feedback is measured downstream of the control valve, however locating a transmitter simply just downstream of the control valve is rarely optimal. Here are three well know examples of process measurements in an oil system improved by thoughtful review:

- Oil temperature measurement downstream of the filters to ensure complete mixing of cooled and bypass streams after the temperature control valve (TCV) and heat exchanger
- Console header pressure measurement downstream of the filters to compensate for element fouling
- Lube and control oil pressure measurement at the main equipment centerline rather than at the oil console to account for head and piping losses

Valve Trim, Actuators, & Positioners

“Selecting the proper valve, actuator, and positioner combination is not easy. It is not simply a matter of finding a combination that is physically compatible. Good engineering judgment must go into the practice of valve assembly sizing and selection to achieve the best dynamic performance from the loop.” (Fisher Controls International LLC., 2019)

There are three primary trim characteristics available when selecting a control valve: quick open (QO), linear, and equal percent (=%). Some valve manufacturers offer variations on these, usually for valves with small Cv ratings. The typical cross section of the three primary types of trim along with typical Cv curves are shown in Figure 3.

Valve Trim Modifications

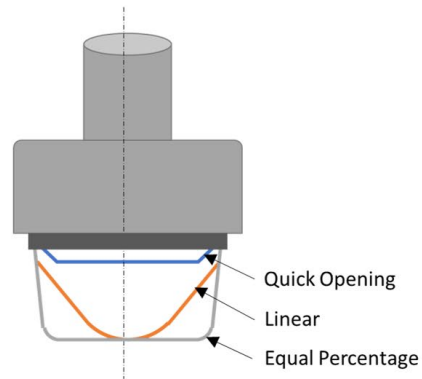

Valve Characteristic Curve

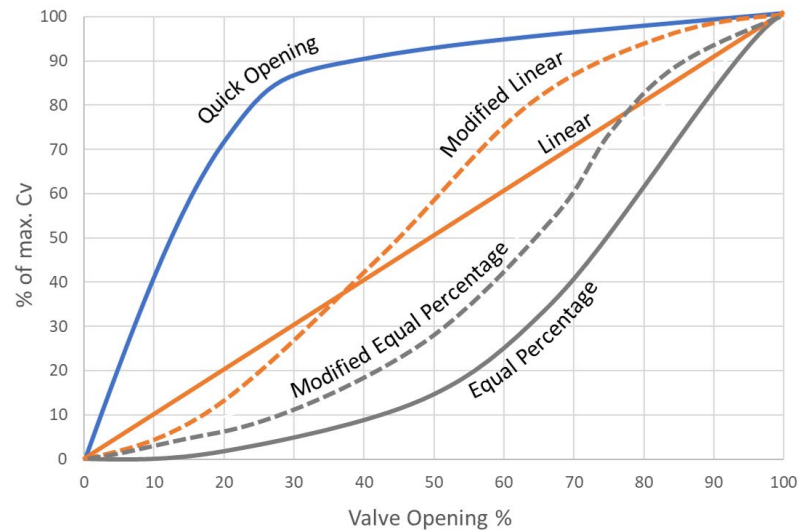

Figure 3. Various Types of Valve Trim Characteristics (Courtesy of simulationHub)

- Quick-opening trim has an inherent valve gain that is greatest at the lower end of the travel range and is used in applications that require maximum flow, quickly
- Linear trim has a constant inherent valve gain throughout its range. It is important that the control valve pressure drop is much more significant than other system pressure losses such as piping, filters, or exchangers.
- Equal-percentage trim has an inherent valve gain that is greatest at the largest valve opening, which can compensate for system losses as flow increases

Equation (1) describes the relation between Inherent Valve Gain and Trim Characteristic

$$\text{Inherent Valve Gain} \propto \text{Slope of the Inherent Characteristic Curve} = (\text{Change in Flow})/(\text{Change in Travel}) \quad (1)$$

Typically, actuators are sized and selected by the valve manufacturer based on the shut-off pressure required, the available stroke of the valve, and action of the valve in its un-energized state.

- direct acting (e.g. increase in control signal results in increase in signal to actuator)
- reverse acting (e.g. increase in control signal results in decrease signal to actuator)

Note that shut-off class is unimportant in oil system applications. Almost all valve services are fail-open, never requiring shut-off. The two exceptions being temperature control and backpressure regulation, neither of which require tight shut-off.

Until recently, control valve positioners used mechanical linkage and contact potentiometers to deliver stem position feedback in order to mitigate assembly friction and other non-linearity issues. Unfortunately, these components were subject to wear, corrosion, and vibration damage that later led to poor loop performance and even premature positioner failures. The current use of “linkageless”, non-contact feedback technology has eliminated these past issues associated with moving parts, including loosening. A clean, dry, and reliable instrument air source continues to be essential for trouble free operation of positioners.

Advanced “I/P” valve positioners also have internal manufacturer configurations and functions that the end user should be aware of such as the following:

- maximum instrument supply pressure
- if a volume booster or quick release valve is present (discussed in next section)
- auto calibration
- dynamic response such as open/close rates
- OEM preselected sets and user customizable tuning for travel control

Volume Boosters & Quick Release Valves

Apply volume boosters whenever control valve stroking speed is critical such as for backpressure regulators and control oil pressure reducing valves.

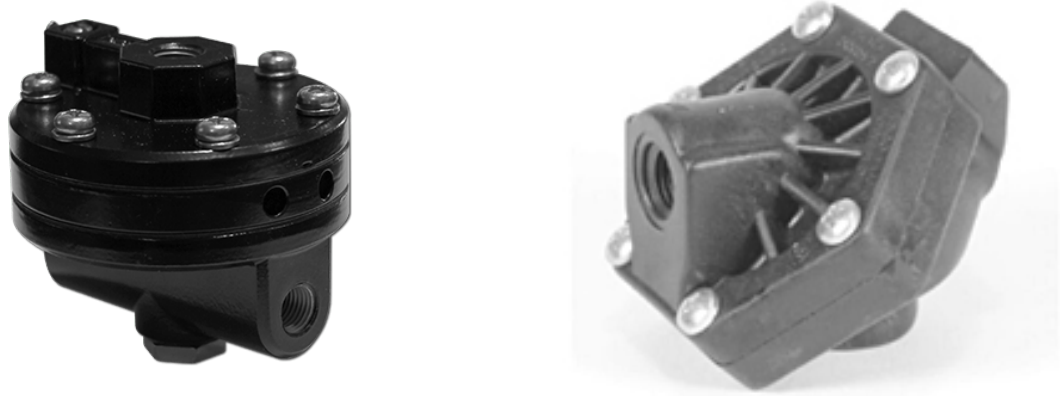

Figure 4. Volume Booster (left, courtesy of Max-Air Technology) and Quick Release Valve (right, courtesy Rexroth)

The valves shown in figure 4 are essentially air relays that supply or exhaust a higher volume of air either to or from the actuator at a pressure controlled by the positioner. Note that in Figure 5 the same regulator, which should have sufficient flow capacity, supplies both positioner and volume booster

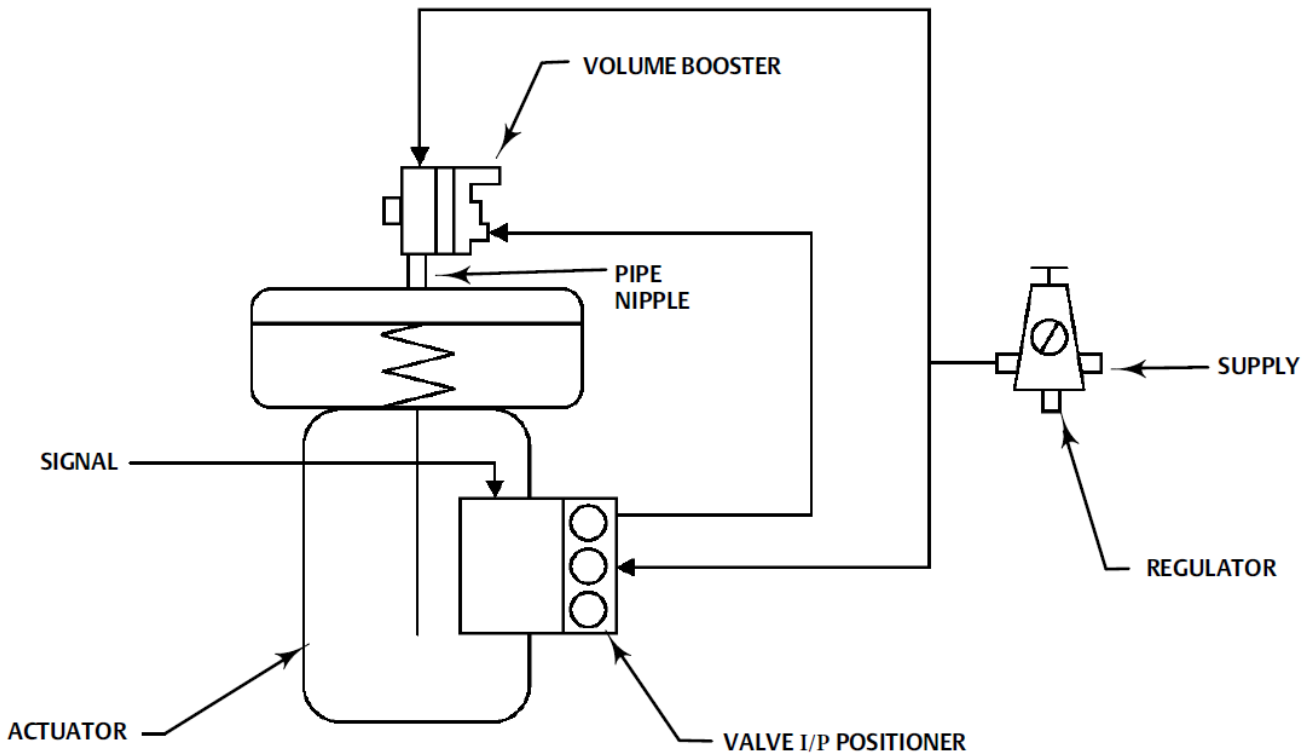

Figure 5. Installation of Volume Booster with respect to positioner and regulator (Courtesy of Fisher Controls)

Prior to tuning the control loop, open the bypass restriction adjusting screw a few turns from the fully closed position. With the actuator in manual operation, slowly turn the restriction clockwise until the booster operates in response to large changes in the input signal, yet allows small changes to move the actuator without initiating booster operation.

Accumulators

When properly maintained, pre-charged accumulators greatly enhance the steady performance of an oil system and prevent upsets. API Standard 614 requires a delivery of normal flow for 4 seconds, which is appropriate when supporting a system with pneumatically actuated control valves.

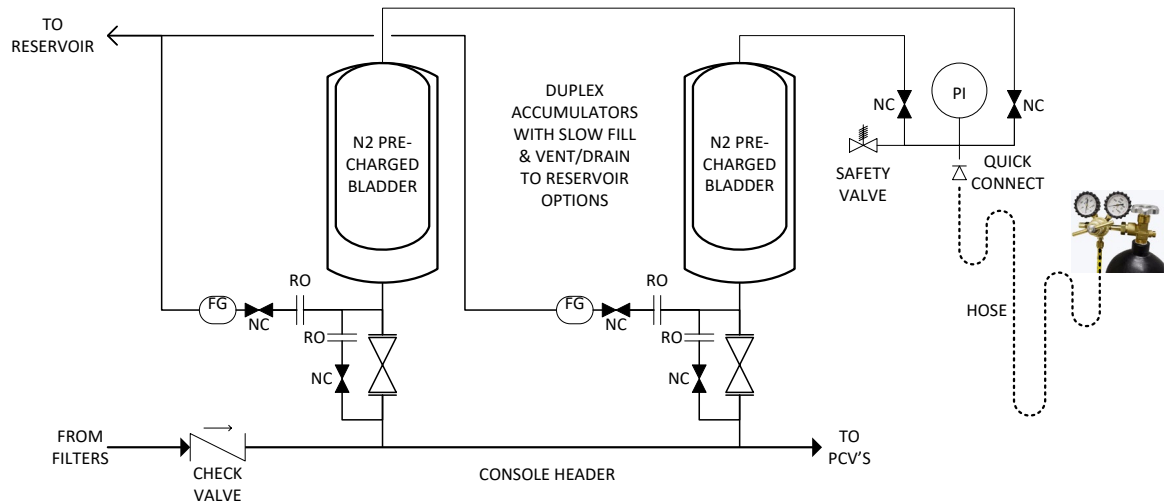

Figure 6. Duplex Accumulators

Note the above emphasis on properly maintained. Whenever possible, split the total delivered flow between at least two independent accumulators. This will allow periodic checking of pre-charge, and if necessary bladder replacement while keeping at least 50% (2 seconds) of accumulator capacity on-line.

Calculating the required accumulator capacity requires the normal delivered oil flow rate, the oil console's header pressure set point, and the minimum allowable header pressure that allows proper function of the signal that starts the standby oil pump. The pre-charge pressure will be 70~80% of the lowest allowable header pressure.

Equation (2) describes the required accumulator volume

$$V_1 = \frac{V_x \left[\frac{P_3}{P_1} \right]^{(1/n)}}{1 - \left[\frac{P_3}{P_2} \right]^{(1/n)}} \quad (2)$$

where;

- V_1 = Volume of accumulator required, *Gallon (Liter)*
- V_x = Volume of oil required, *Gallon (Liter)*
- P_2 = Oil console header pressure, *psiA (kg/cm²)*
- P_3 = Minimum header pressure, *psiA (kg/cm²)*
- P_1 = Pre-charge pressure @ 49C, *psiA (kg/cm²)*
- n = Polytropic Constant for Nitrogen, *1.4*

Example:

$$\begin{aligned} V_x &= 5.33 \text{ Gallons} = (80 \text{ GPM} / 60 \text{ seconds}) 4 \text{ seconds} \\ P_2 &= 134.7 \text{ psiA} \\ P_3 &= 114.7 \text{ psiA} \\ P_1 &= 91.8 \text{ psiA} = 77 \text{ psiG} \\ V_1 &= 57.7 \text{ Gallons total accumulator volume required} \end{aligned}$$

Two, 30 Gallon accumulators recommended with a N2 pre-charge of 77 psiG

APPLICATION CONSIDERATIONS

Oil systems have a variety of control loop applications for pneumatically actuated valves ranging from very limited response such as temperature control, to extremely dynamic such as a backpressure regulation during pump startup. The specific requirements of each application must be understood to successfully select and tune control loop hardware.

Temperature

Temperature control is no doubt the most frequently tuned loop in oil system applications since the only other option is thermostatic type controlled valves. It is typically the least demanding application to tune, but it is often the least regarded. Failure to maintain proper and consistent lube oil temperature delivered to the equipment bearings can result in bearing temperature changes and on rare occasions can also affect machinery vibration. There are two valve options from which to choose:

- A two-way valve that allows hot oil to bypass the heat exchanger and mix with the cooled oil downstream of the heat exchanger outlet
- A three-way valve that actively mixes hot and cold oil streams

Note that the two-way valve option relies upon the pressure drop of the heat exchanger to function, which is less than 10 psi at normal operating conditions by design, but can be significantly greater than 10 psi during cold startup. Equal percent characteristic trim is generally recommended and widely applied in this specific application.

Due to the nature of their design, valve manufacturers generally only offer linear characteristic trim for three-way valves.

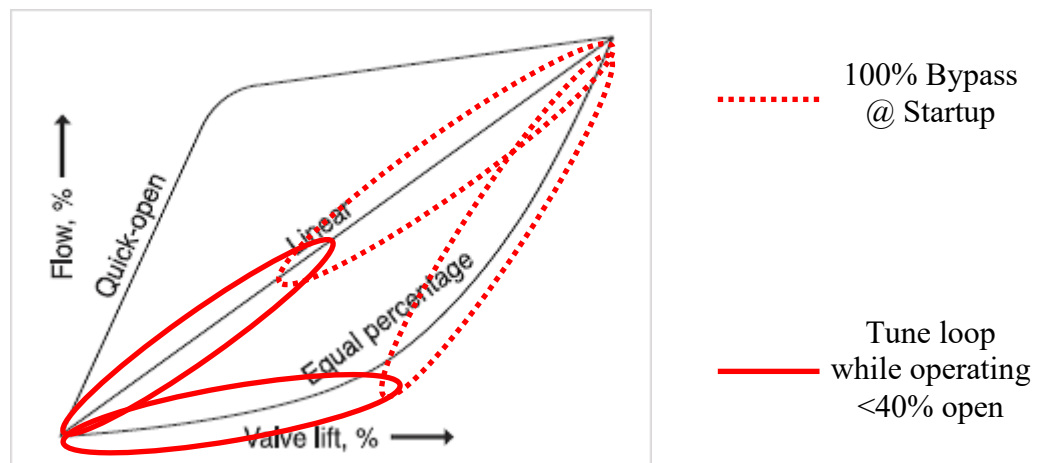

Figure 7. Oil temperature bypass at startup vs. normal operation

Temperature Control Valves (TCV) are always fail “closed” (FC) or fail last/locked (FL), directing all oil to the coolers in the event of loss of signal or instrument air. From the control loop perspective, this service is considered “reverse acting” since an increase in process variable signal (oil temperature) results in decrease of control signal (4~20 mA) to the actuator positioner. Due to the very long time constant, Proportional-Integral (PI) control is the most suitable control method for this service.

During commissioning, allow the oil system to reach normal operating temperatures before attempting to tune this PI loop. Ideally, the oil system will be able to reach operating temperature with the TCV only 10~40% open beforehand. Temporarily throttling the exchanger cooling water will likely be necessary to achieve this. On systems with duplex exchangers, check the loop performance by quickly performing a switchover to a cold standby exchanger. Further optimization may be required once the main equipment is in operation and the reservoir oil temperature has stabilized under actual heatload.

Seal Oil Differential Pressure (or Level)

Oil seals have essentially been displaced by dry gas seals on new equipment, and many existing compressors are now being retrofitted with dry gas seals. However, there are currently many compressor seal oil applications still in operation that can benefit from an upgrade of their differential pressure control, especially if the application is equipped with pneumatic transmitters.

Pressure differential control valves (PDCV) in seal oil service may be nearly closed during equipment start up due to low equipment process pressure. The maximum flow coefficient (Cv) or valve position may be required during normal operation or equipment process settle out after shutdown. Due the requirement to perform under such a relatively broad range, linear characteristic trim should be the first choice.

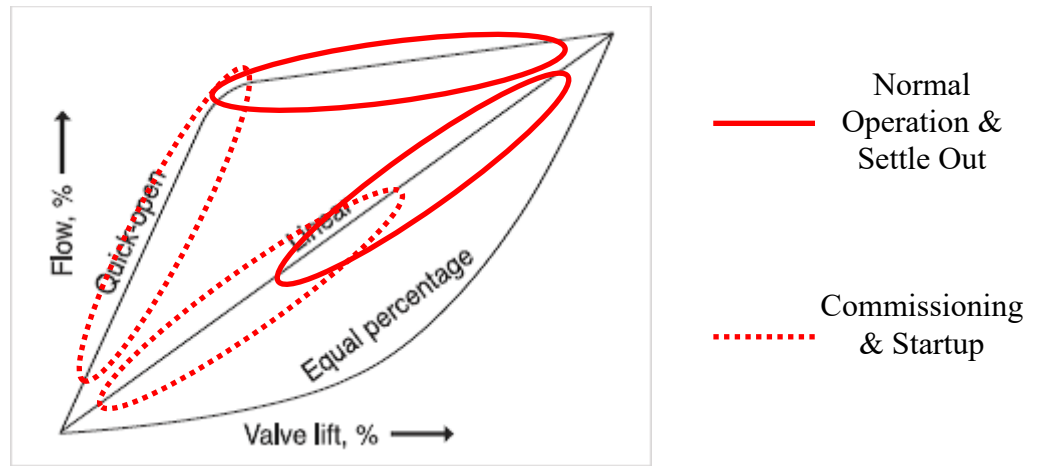

Figure 8. Seal oil pressure reduction at commissioning/startup vs. normal operation/settle out

Seal oil PDCVs are always fail “open” (FO), allowing oil flow in the event of loss of signal or instrument air. From the control loop perspective, this service is considered “direct acting” since an increase in process variable signal (differential pressure or level) results in increase of control signal (4~20 mA) to the actuator positioner. Due to the stable up and downstream conditions, Proportional-Integral (PI) control is the most suitable control method for this service.

During commissioning, allow the oil system to reach normal operating temperatures before attempting to tune this PI loop. Put all other oil system control loops other than the TCV in manual operation and adjust to normal operating conditions beforehand as well. Make step changes to the loop set point between normal and alarm conditions and tune the control loop accordingly.

Lube Oil

Bearing oil pressure control valves (PCV) are typically the highest delivered flow, highest pressure reduction, however the least dynamic response required since the bearing requires a steady oil pressure and flow.

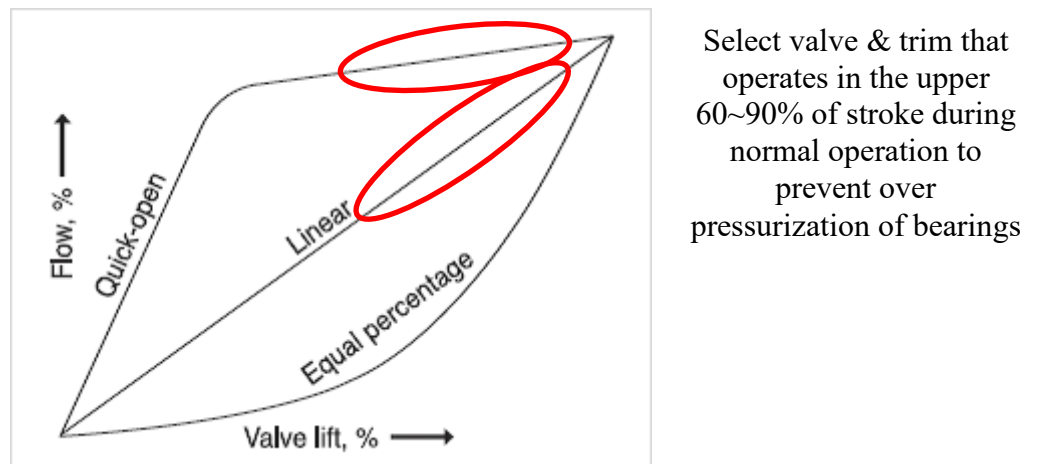

Figure 9. Lube oil pressure reduction

Lube oil PCVs are always fail “open”, allowing oil flow to the equipment in the event of loss of signal or instrument air. From the control loop perspective, this service is considered “direct acting” since an increase in process variable signal (delivered oil pressure) results in increase signal (4~20 mA) to the actuator positioner. Due to the stable up and downstream conditions, Proportional-Integral (PI) control is the most suitable control method for this service.

During commissioning, allow the oil system to reach normal operating temperatures before attempting to tune this PI loop. Put all other oil system control loops other than the TCV in manual operation and adjust to normal operating conditions beforehand as well. Make $\pm 20\%$ step changes to the BPR loop set point to simulate pump startup & shutdown transients and tune the lube oil control loop accordingly.

Control Oil

Steam turbine inlet and extraction servo-valves must be able to perform a full stroke in under a second and are typically hydraulically actuated using oil from the console. The oil console PCVs serving these steam controls must deliver very dynamic transient flow when

required by the turbine, but typically have the lowest pressure reduction. If the transient flow requirements are extreme, the interconnecting pipe between oil console and actuator is undersized, or there are special filtration requirements that had been unaccounted for, then equal percentage trim may be the better selection.

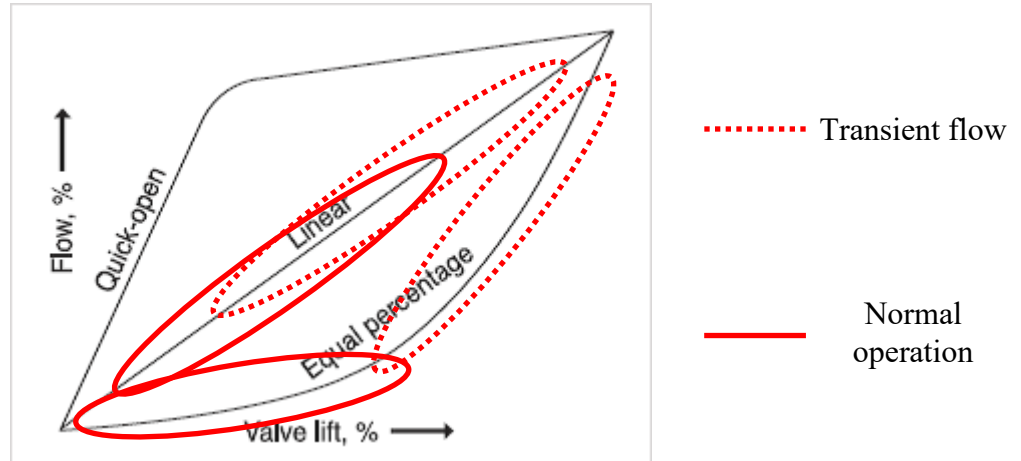

Figure 10. Control oil normal pressure reduction vs. transient flow condition

Control oil PCV's are always fail "open", ensuring oil pressure to the steam controls (which are in turn fail "closed") in the event of loss of signal or instrument air. From the control loop perspective, this service is considered "direct acting" since an increase in process variable signal (delivered oil pressure) results in increase signal (4~20 mA) to the actuator positioner. Due to the transient downstream demands, Proportional-Integral-Derivative (PID) control is the most suitable control method for this service and a quick release valve or volume booster is highly recommended.

During commissioning, allow the oil system to reach normal operating temperatures before attempting to tune this PI loop. Put all other oil system control loops other than the TCV in manual operation and adjust to normal operating conditions beforehand as well. Manually stroke the steam turbine actuator position between 0 to 100% in under second, then 100 to 0% in under a second and tune the control oil PID loop accordingly. Once satisfied, make $\pm 20\%$ step changes to the BPR loop set point to simulate pump startup & shutdown transients and confirm the control oil PID loop is stable.

Back Pressure Regulation

The backpressure regulator (BPR) has the most dynamic response required during pump switchovers and by definition the highest pressure drop. During 1-to-2 and 2-to-1 pump switchovers, the amount of flow through this valve easily changes by a factor of 10. This is the easiest valve to undersize since pump manufacturers understate rated flow and equipment manufacturers are conservative on required oil flow.

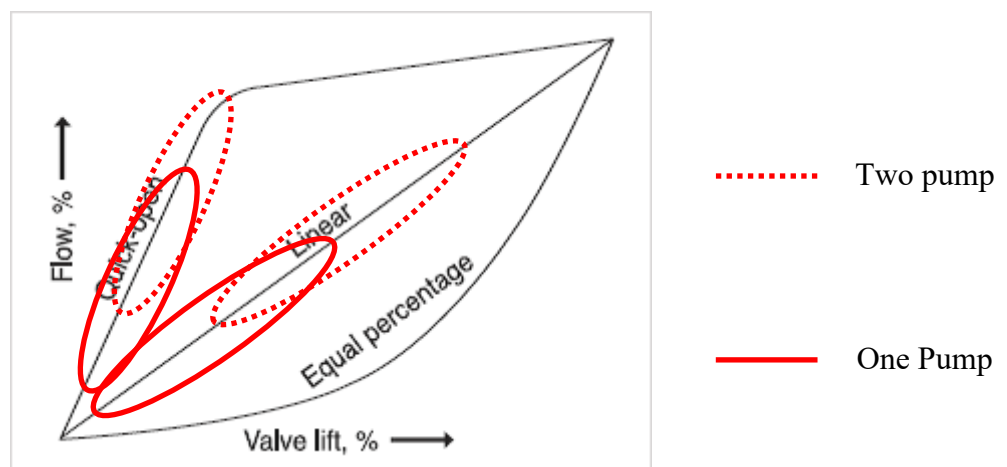

Figure 11. One pump vs two pump backpressure regulation

BPRs are always fail "closed" (FC), directing oil to the equipment in the event of loss of signal or instrument air. From the control loop perspective, this service is considered "reverse acting" since an increase in process variable signal (console header pressure) results in decrease signal (4~20 mA) to the actuator positioner. Due to the very dynamic upstream conditions, Proportional-Integral-Derivative (PID) control is the most suitable control method for this service and a volume booster is highly recommended.

During commissioning, allow the oil system to reach normal operating temperatures before attempting to tune this PID loop. Put all other oil system control loops other than the TCV in manual operation and adjust to normal operating conditions beforehand as well. Perform 1-to-2 and 2-to-1 pump switchovers and tune the back pressure regulator PID loop accordingly. Once satisfied, place all control valves in automatic control, repeat pump startup & shutdown transients, and confirm that the control loops are stable. Finally, perform a 1-to-1 automatic pump switchover to reconfirm all control loops are stable.

CASE STUDIES

The three cases presented illustrate achievable performance by pneumatically actuated control valves during pump switchovers. This data was collected during the four-hour witness test at the oil console manufacturer's shop prior to shipment. API Standard 614 prescribes performance of oil consoles under the following conditions:

- Delivered oil pressures, temperature and viscosity within the recommended normal range of operation
- Pressure Limiting Valve (PLV) setting must not be reached
- PCVs are capable of controlling the oil pressure when either and both pumps are in operation
- Upon trip of the main oil pump, the standby oil pump starts automatically and returns the system to normal operating pressures without the delivered oil pressures falling more than half way between set point and the equipment trip limit

The following design selections and test equipment were common for all three cases:

- All consoles were furnished with multiple accumulators pre-charged between 170~175 psiG
- All valve actuators in backpressure regulator service were furnished with volume boosters
- All valve actuators in control oil service were furnished with quick release valves
- All transmitters were reconfigured to minimum selectable damping
- Moore Industries M535 Process Controllers were used by the shop for loop control
- A shop test switch, located at the same sensing location as the actual pressure transmitter used by the DCS, was used to start the standby pump

The following pressures are plotted as a function of time with a data acquisition rate of 0.1 Hz (100 millisecond) per channel:

- Main Oil Pump (MOP) discharge
- Auxiliary Oil Pump (AOP) discharge
- Console header downstream of filter, upstream of PCVs
- Delivered lube oil
- Delivered control oil

Case Study 1 (029)

Figure 12 is the Piping & Instrumentation Diagram (P&ID) from a special purpose lube & control oil console designed to serve a Propylene Refrigerant Compressor (PRC) string of equipment. Dual 80-gallon accumulator selection supported a normal total delivered flow of 174 GPM for 4 seconds, as well as a transient control oil increase of 107 GPM for 2 seconds. Figure 13 demonstrates that the BPR successfully maintained both pump discharge pressures well below the system MAWP of 400 psiG during startup of a second pump. Figure 14 demonstrates that the BPR also successfully maintained system pressures during shutdown of the second pump. Figure 15 demonstrates a successful automatic pump switchover with a Start Auxiliary Oil Pump (SAOP) header set point of 220 psiG. Note that the brief instability (ringing) in the AOP discharge pressure is tolerable since the delivered oil pressures experience little if any disturbance.

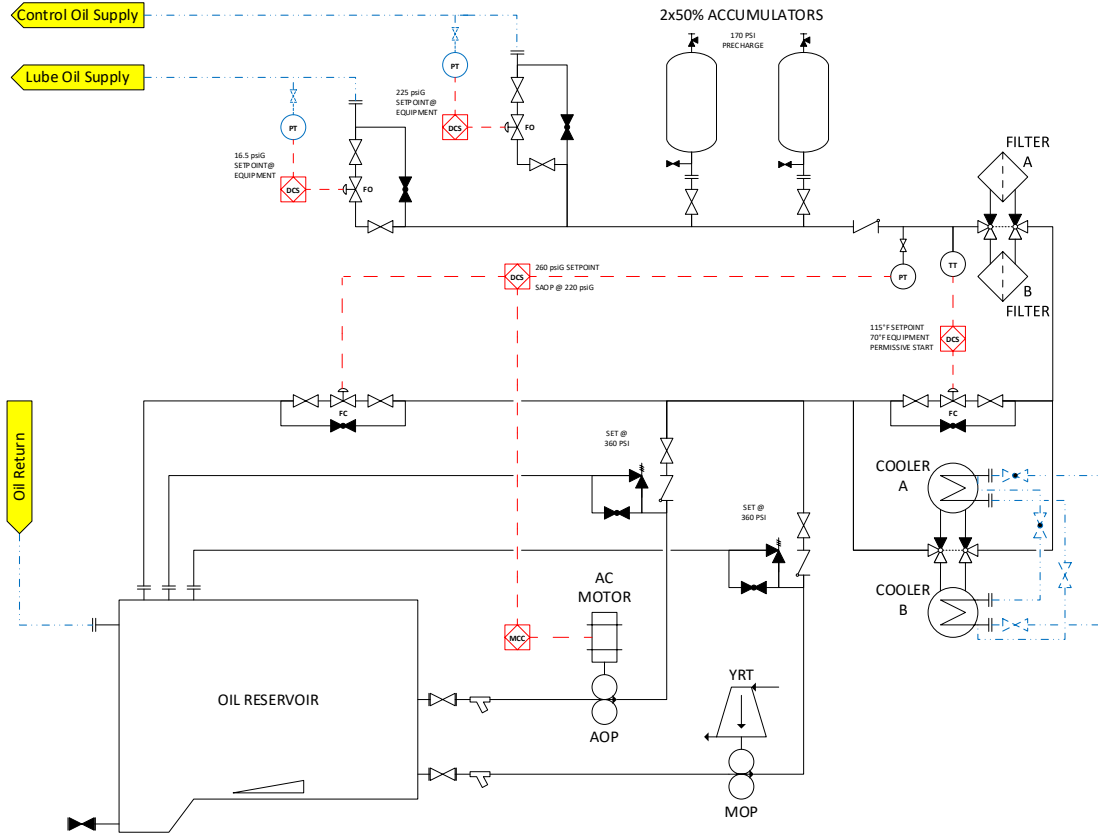

Figure 12. Case 1 & 2: Piping & Instrumentation Diagram

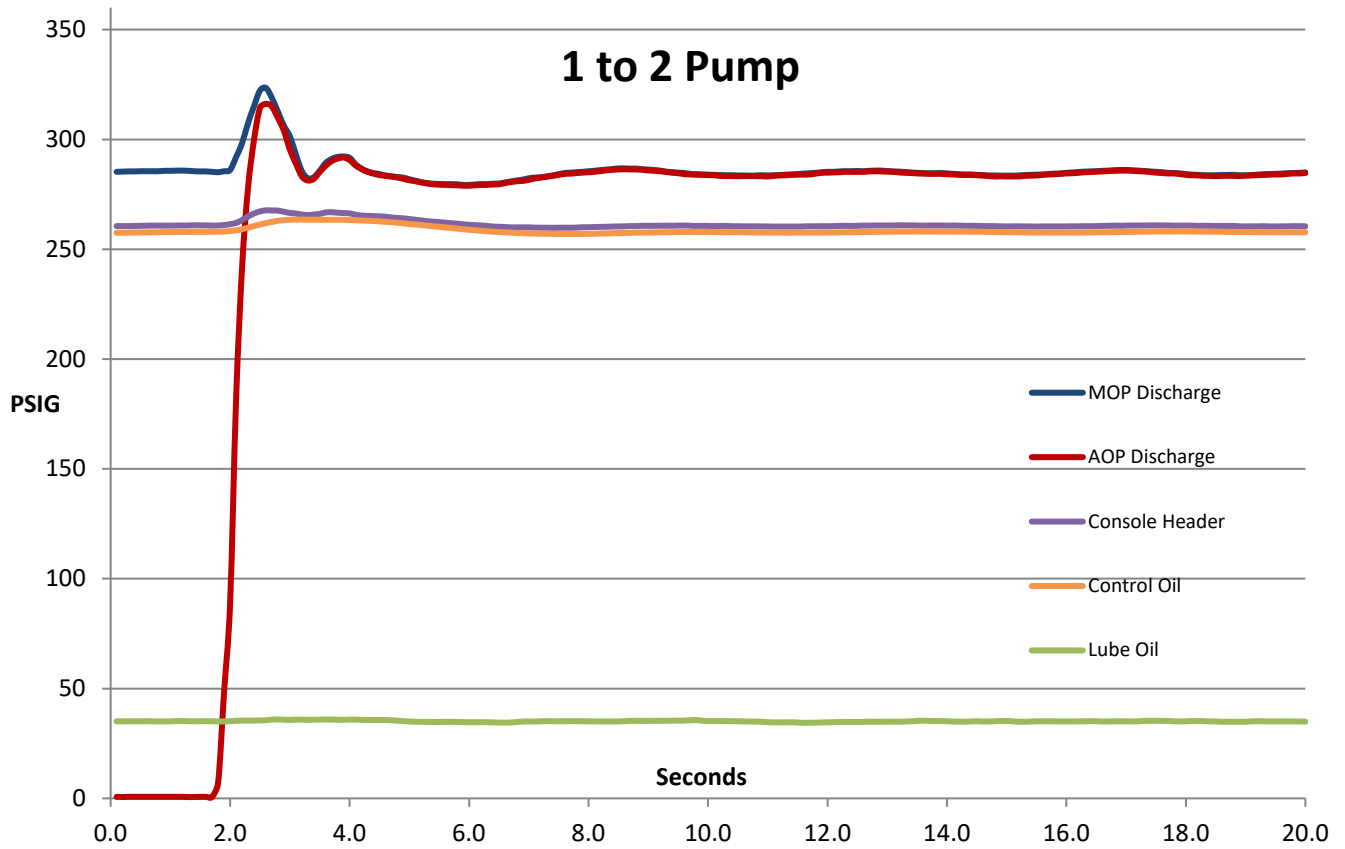

Figure 13. Case 1: AOP started during normal operation

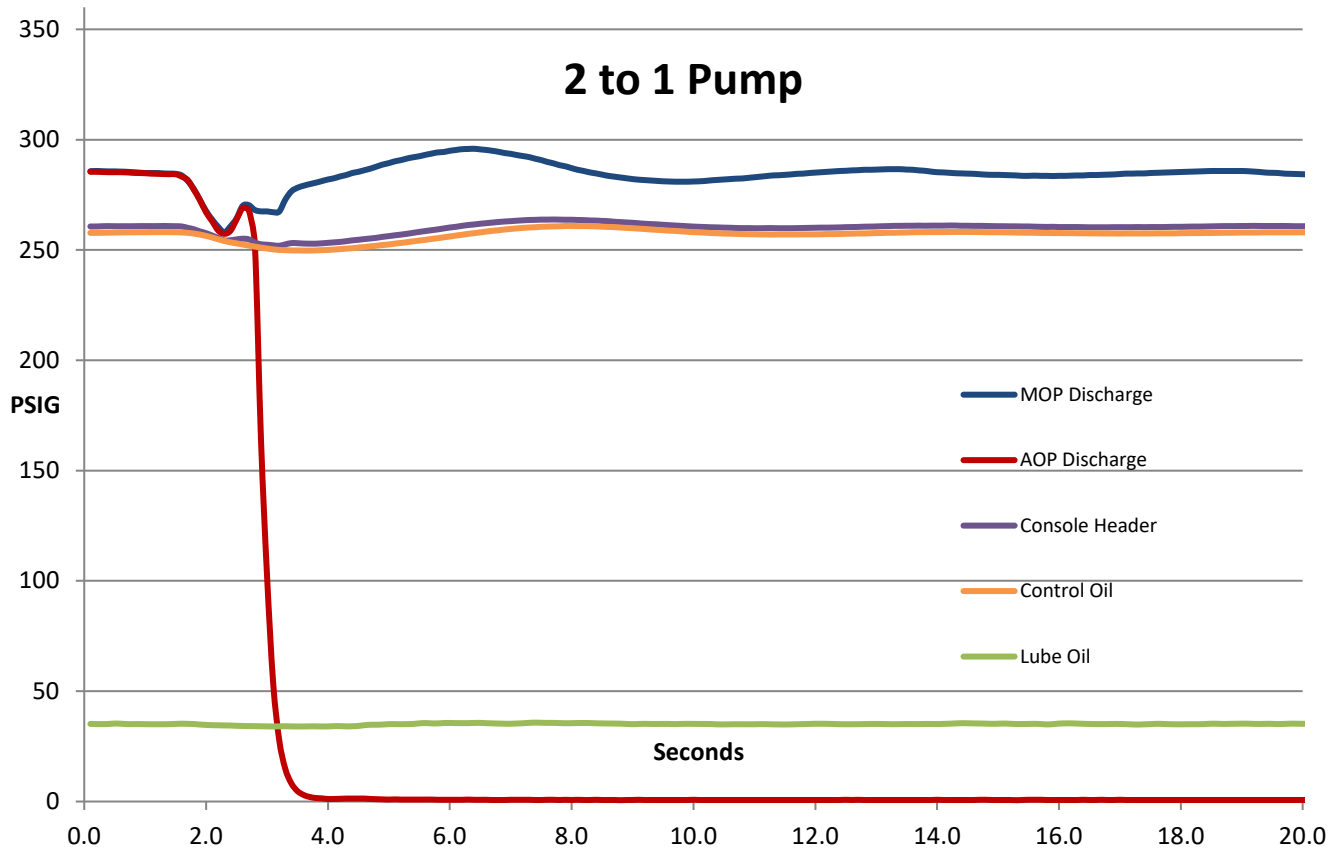

Figure 14. Case 1: AOP turned off

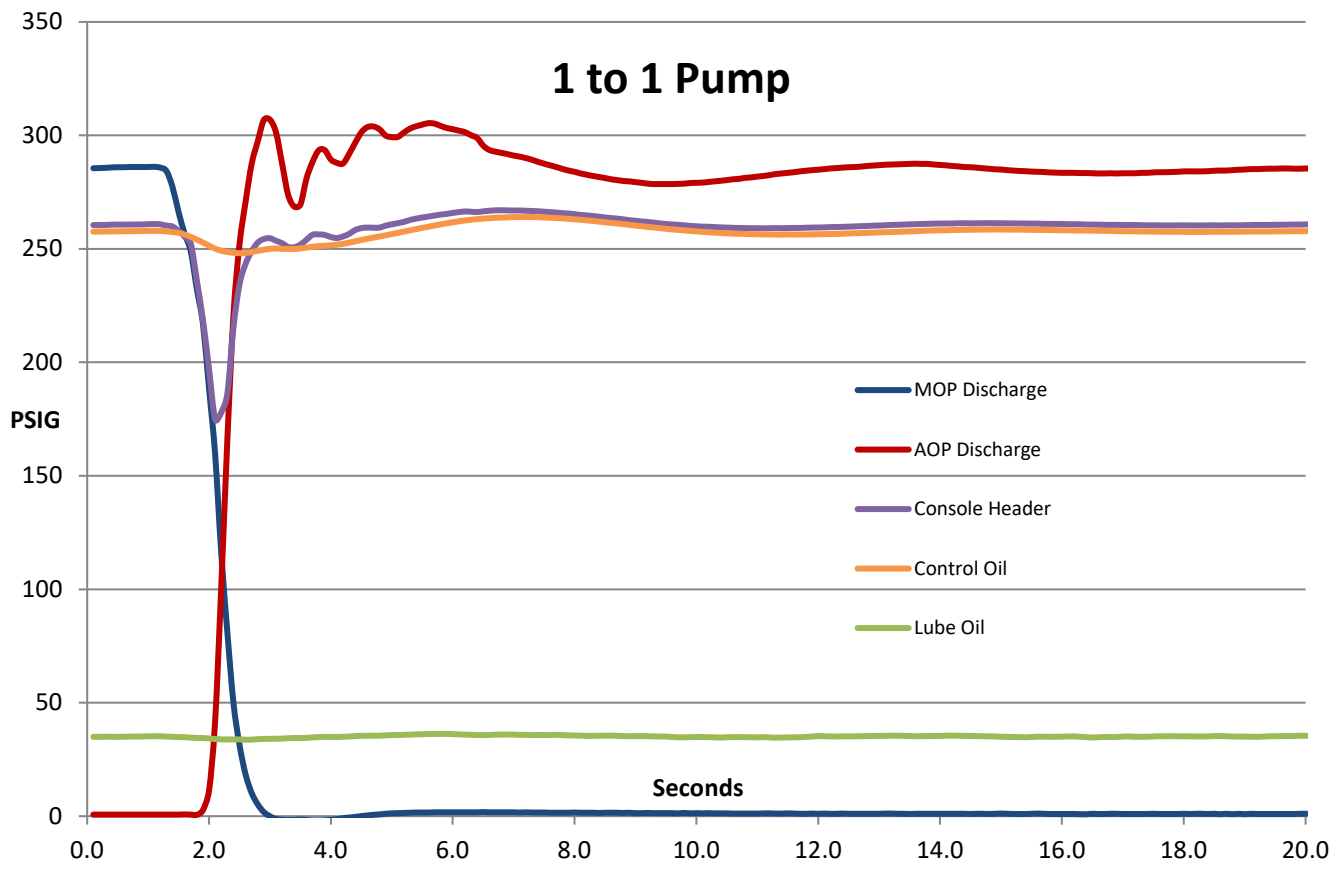

Figure 15. Case 1: Automatic Switchover

Case Study 2 (030)

Figure 12 is also the P&ID for a special purpose lube & control oil console designed to serve a Binary Refrigerant Compressor (BRC) string of equipment. Dual 100-gallon accumulator selection supported a normal total delivered flow of 225 GPM for 4 seconds, as well as a transient control oil increase of 58 GPM for 2 seconds. Figure 17 demonstrates that the BPR successfully maintained both pump discharge pressures well below the system MAWP of 400 psiG during startup of a second pump. Figure 18 demonstrates that the BPR also successfully maintained system pressures during shutdown of the second pump. Figure 19 demonstrates a successful automatic pump switchover with a SAOP header set point of 220 psiG. Note that after all three pump switchovers the BPR took up to 30 seconds to completely restore the system pressures to set point. While not ideal, this performance was still tolerable since the delivered oil pressure disturbances were within acceptable tolerance.

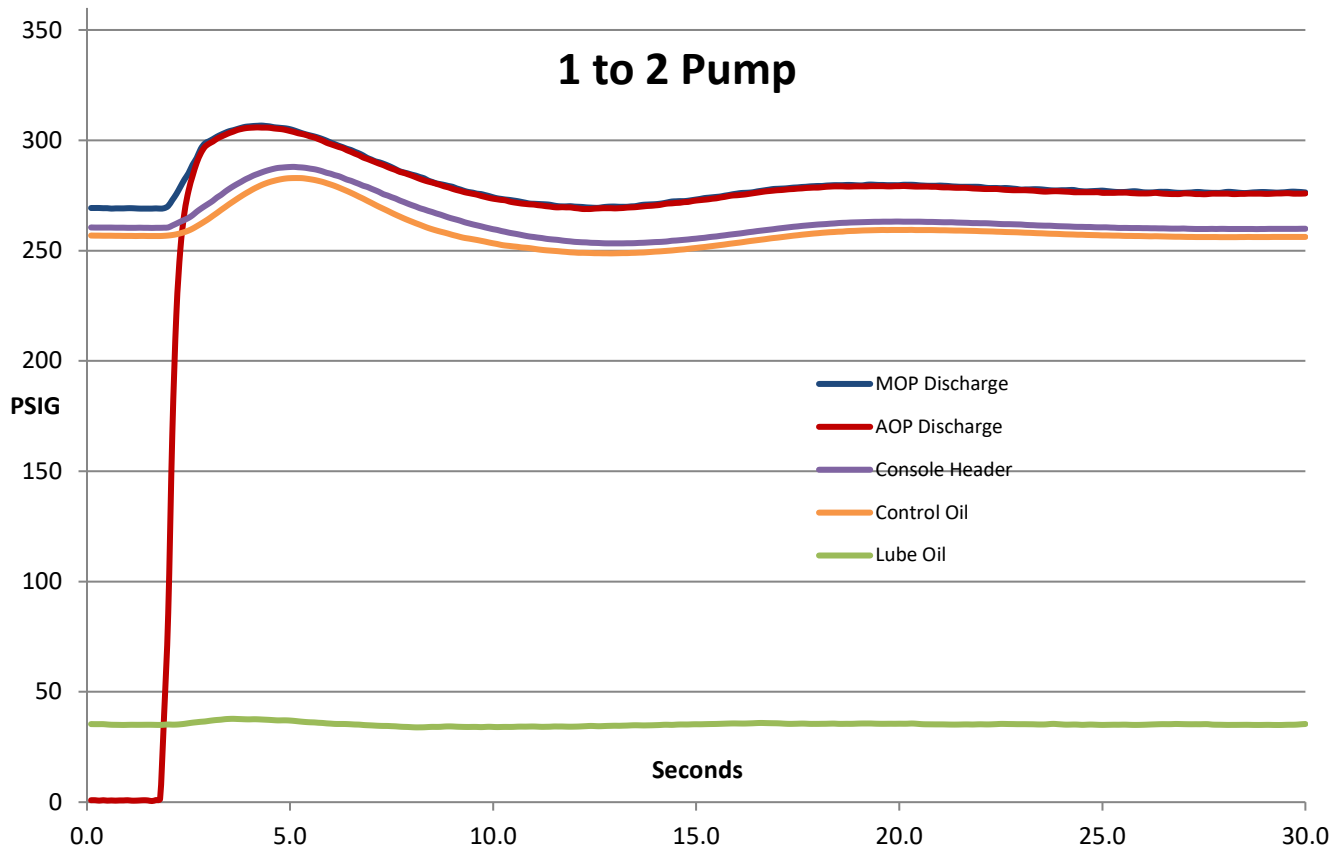

Figure 17. Case 2: AOP started during normal operation

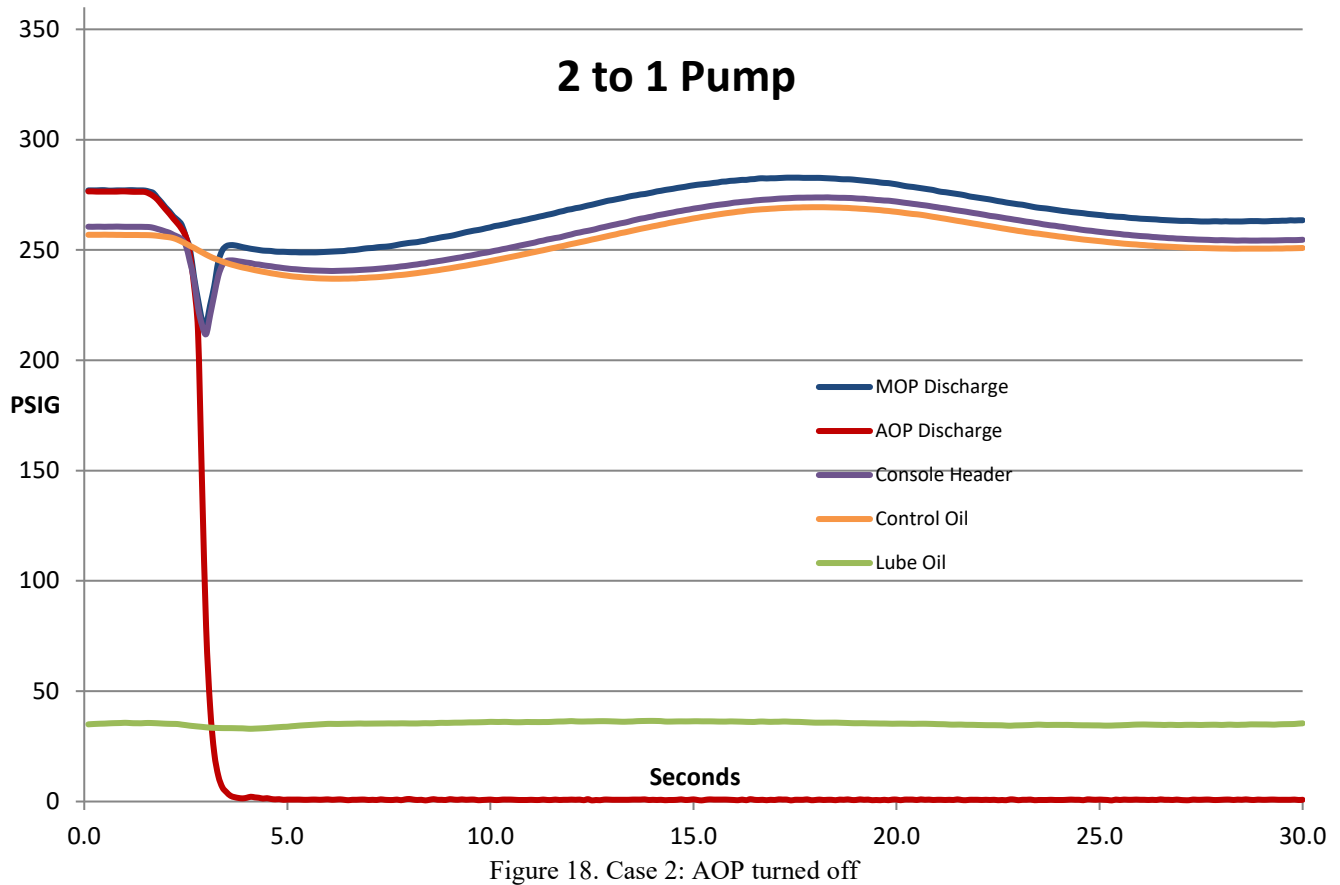

Figure 18. Case 2: AOP turned off

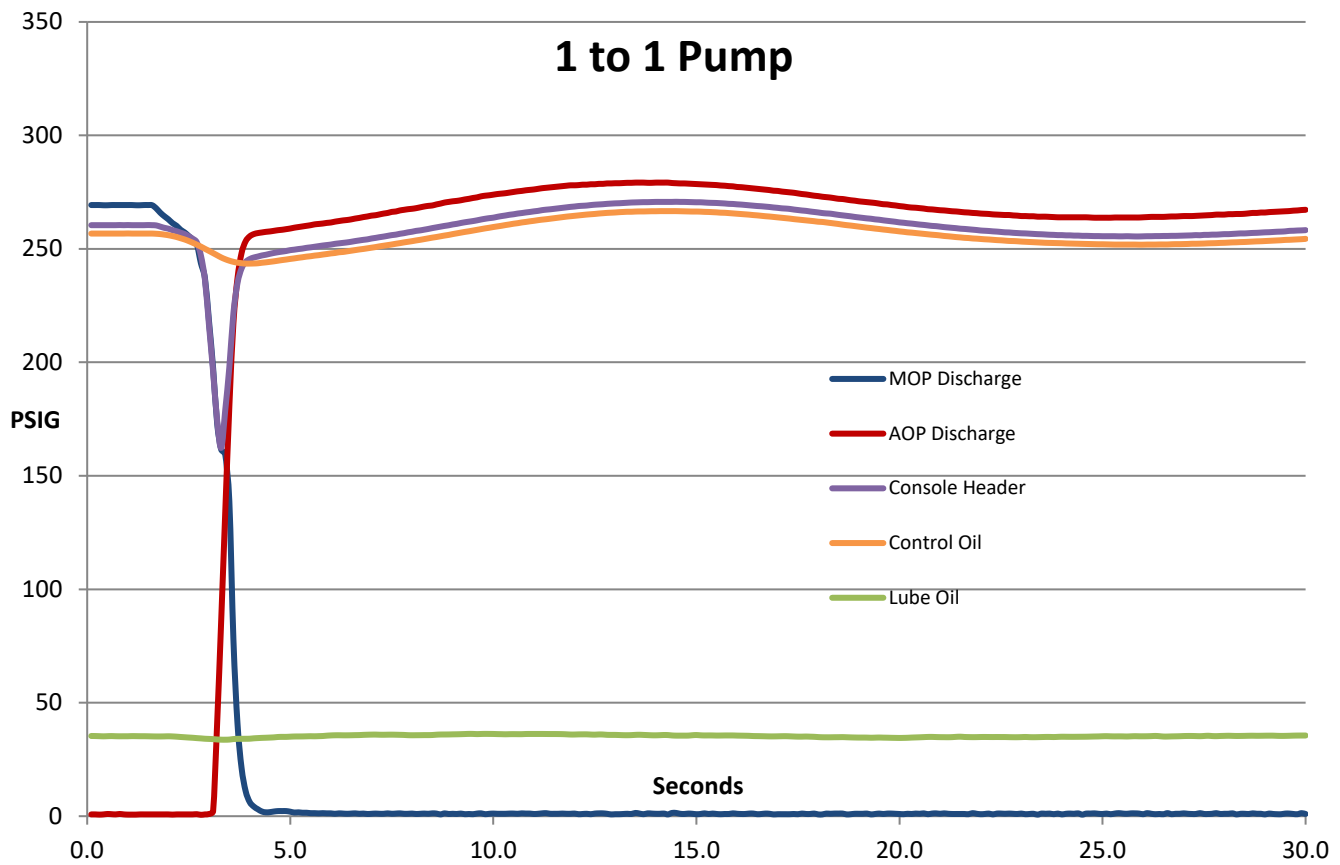

Figure 19. Case 2: Automatic Switchover

Case Study 3 (014)

Figure 20 is the P&ID from a special purpose lube & control oil console designed to serve both PRC and Ethylene Refrigeration Compressor (ERC) strings of equipment. Triple 120-gallon accumulator selection supported a normal total delivered flow of 459 GPM for 4 seconds, as well as a transient control oil increase of 190 GPM for 2 seconds. Figure 21 demonstrates that the BPR successfully maintained both pump discharge pressures well below the system MAWP of 300 psiG (20.7 barG) during startup of a second pump. Figure 22 demonstrates that the BPR successfully maintained system pressures during shutdown of the second pump, however the long recovery afterward must be noted. In fact, the original SAOP set point was reduced from 220 of 190 psiG (13.1 barG) during system tuning to accommodate this lower performance. Fortunately, this tradeoff did not affect the automatic pump switchover, successfully demonstrated in Figure 23.

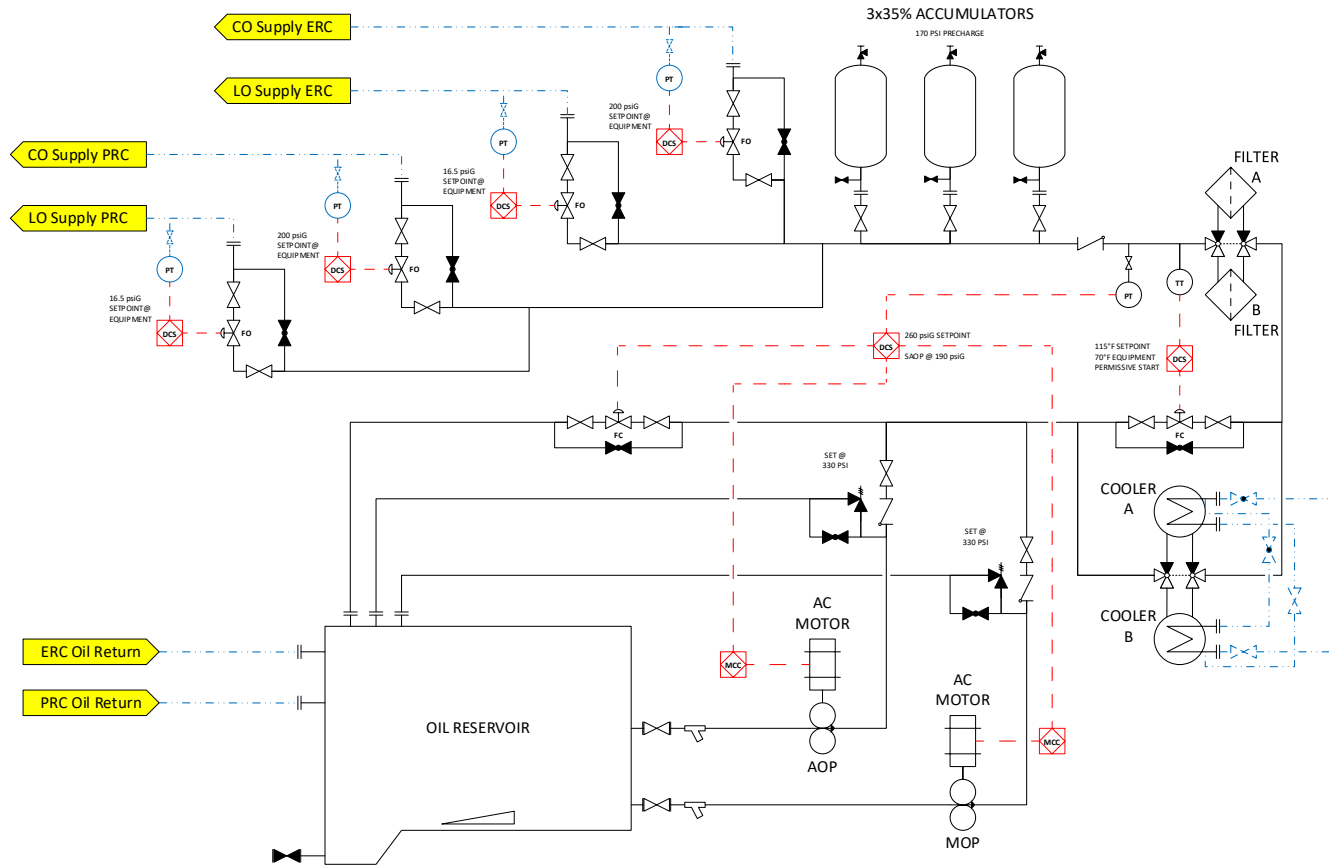

Figure 20. Case 3: Piping & Instrumentation Diagram

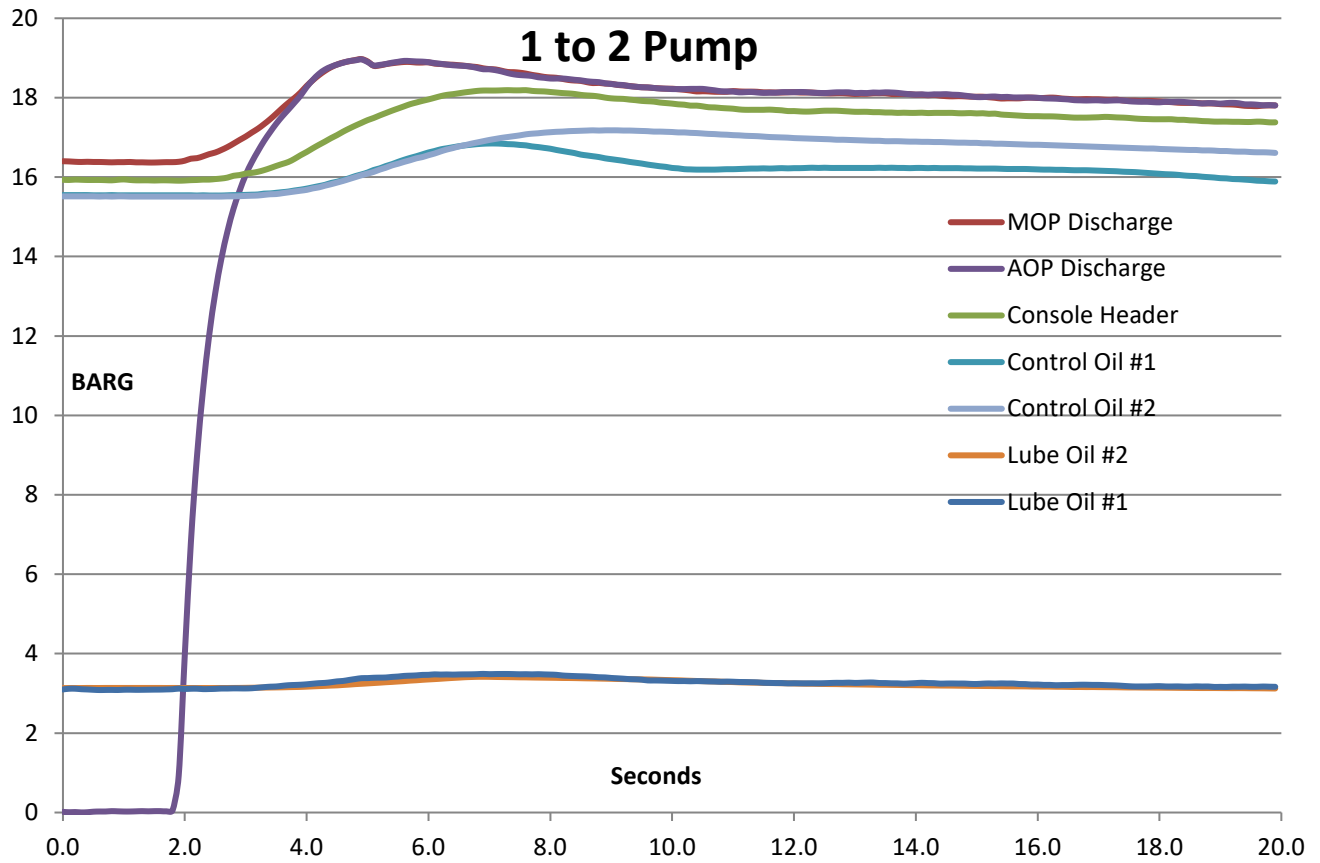

Figure 21. Case 3: AOP started during normal operation

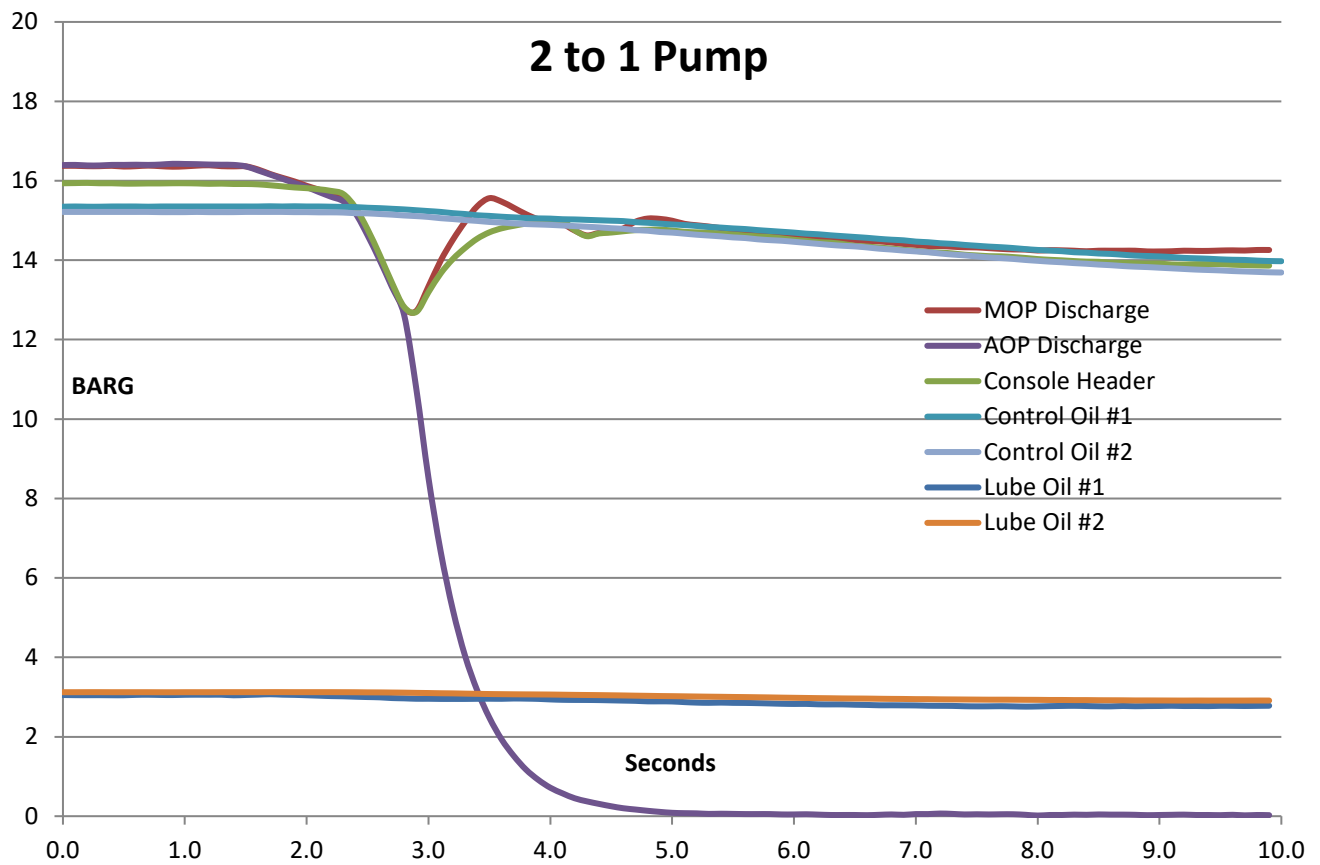

Figure 22. Case 3: AOP turned off

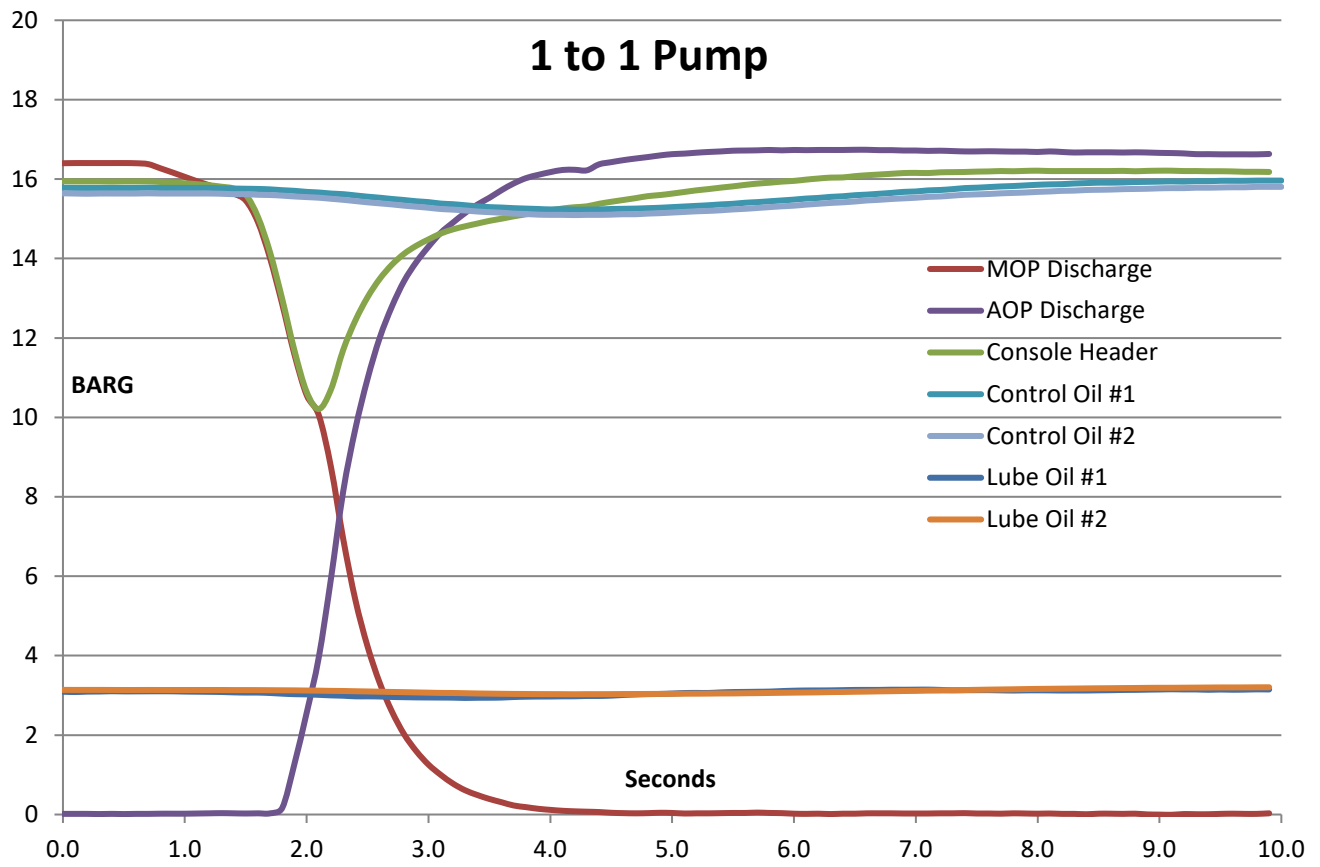

Figure 23. Case 3: Automatic Switchover

SUMMARY

Electronic transmitters are generally capable of 100-millisecond response once the damping configuration is adjusted from factory default to the minimum selectable. Table 1 below summarizes the recommended selections for pneumatic control valve hardware and tuning based on the oil system application.

	TCV	PDCV/LCV	LO PCV	CO PCV	BPR
Un-Energized	Closed	Open	Open	Open	Closed
Control Action	Reverse	Direct	Direct	Direct	Reverse
Equal Percent	2-way valve	No	No	2 nd Choice	No
Linear	3-way valve	1 st Choice	1 st Choice	1 st Choice	1 st Choice
Quick Open	No	2 nd Choice	2 nd Choice	No	2 nd Choice
Volume Booster	No	No	No	No	Yes
Quick Release Valve	No	No	No	Yes	No
Accumulator	N/A	N/A	Yes	Yes	Yes
Proportion	Yes	Yes	Yes	Yes	Yes
Integral	Yes	Yes	Yes	Yes	Yes
Derivative	No	No	No	Yes	Yes
Autotune	No	Yes	Yes	Yes	No
Self-Adaptive	Maybe	No	No	No	No

Table1: Summary of recommendations

CONCLUSIONS

Oil system control loops are some of the toughest applications and poor loop performance will lead to unplanned outages and lost production. Proper upfront specification of pneumatically actuated control valves is critical to reliable console operation and unit availability. Even with ideal hardware selection, console operating performance must be challenged both at the manufacturer prior to shipment, and then during commissioning in the field. Tuning control loops for optimal performance during pump switchovers is essential, as they are probably the single largest contributor to spurious equipment trips. Attendance of the shop performance test to confirm achievable performance for the intended service by the appropriate stakeholders will significantly decrease regrets later.

NOMENCLATURE

=%	= Equal Percent characteristic valve trim
AOP	= Auxiliary Oil Pump, or Standby Oil Pump
BPR	= Back Pressure Regulator
C_v	= Valve flow coefficient
DCS	= Distributed Control System
ERC	= Ethylene Refrigeration Compressor
FC	= Fail Closed
FL	= Fail Last or Fail Locked
FO	= Fail Open
GPM	= Gallons Per Minute
MCC	= Motor Control Center
MAWP	= Maximum Allowable Working Pressure
P&ID	= Piping & Instrumentation Diagram
PCV	= Pressure Control Valve
PDCV	= Pressure Differential Control Valve
PLC	= Programmable Logic Controller
PLV	= Pressure Limiting Valve
PRC	= Propylene Refrigeration Compressor
QO	= Quick Open characteristic valve trim
SAOP	= Start Auxiliary Oil Pump
TCV	= Temperature Control Valve

REFERENCES

- API, 2008, *ANSI/API Standard 614 Fifth Edition, Lubrication, Shaft-sealing and Oil-control Systems and Auxiliaries*, 1220 L Street, N.W., Washington, D.C. 20005 USA.
- Cheema, J., 2007, "Specifying Accumulators", Turbomachinery International, March/April, 2007.
- Fisher Controls International LLC, 2017, *Control Valve Handbook, Fifth Edition*, Marshalltown, Iowa 50158 USA
- Fisher Controls International LLC, 2018, "White Paper: Advantages of Using Linkageless, Non-Contact Feedback Technology in Digital Positioners", Marshalltown, Iowa 50158 USA
- Gerry, J., 2005, "Adaptive Tuning - Expectations and Limitations", ExperTune Inc.
- ISA, 2009, *ANSI/ISA-5.1-2009, Instrumentation Symbols and Identification*, Research Triangle Park, North Carolina 27709 USA.
- Kumar, P, 2017, "Valve trim design using Control Valve Performer", simulationHub, Centre for Computational Technologies Pvt. Ltd.
- Locke, S., 1984, "An Empirical Solution to an Anti-Surge Control Problem," *Proceedings of the Thirteenth Turbomachinery Symposium*, Turbomachinery Laboratory, Texas A&M University, College Station, TX. pp. 51-58.
<https://doi.org/10.21423/R1TH4D>
- Morrison, F., 1977, "Design Philosophy for Lube and Seal Oil Systems", Elliott Company
- Salisbury, R., Stack, R., and Sassos. M., 1984, "Lubrication and Seal Oil Systems", *Proceedings of the Thirteenth Turbomachinery Symposium*, Turbomachinery Laboratory, Texas A&M University, College Station, TX. pp. 151-176.
<https://doi.org/10.21423/R17Q2F>
- Sassos, M., Babyak, M., and Zerbe, J., 1993, "Lubrication and Seal Oil Systems-Common Problems and Practical Solutions," *Proceedings of the Twenty-Second Turbomachinery Symposium*, Turbomachinery Laboratory, Texas A&M University, College Station, TX. pp. 51-64. <https://doi.org/10.21423/R1WM1X>
- Unknown, June 1st, 2018, Pros and cons of autotuning control: Part 1, Control Engineering
- VanDoren, V., July 1st, 2003, Loop Tuning Fundamentals, Control Engineering

ACKNOWLEDGEMENTS

Thanks to Joe Zerbe and Dale Klingensmith for their mentorship.

Thanks to Chad Gordon for his long hours spent on the test floor in Belle Vernon.