

2020

CHRISTINA VAUGHN

THE THREE SISTERS

# THE THREE SISTERS



## DEDICATION

To my parents, step-parents, and grandparents, thank you for raising me to be the woman I am today. Thank you for my childhood weekends at the farm, cooking in the kitchen, and working at the restaurant. These are just a few of the moments in my life that created the idea behind this project.

To my support system of friends, and mentors thank you for guiding me through this past year. It was full of laughter, adventures, and so many learning experiences.

# THE THREE SISTERS

MASTERS OF ARCHITECTURE | CHRISTINA VAUGHN

---

ANDREW TRIPP | COMMITTEE CHAIR

---

ALI AHMED | COMMITTEE COCHAIR

---

MICHAEL O'BRIEN | COMMITTEE MEMBER

---

BRUCE DVORAK | COMMITTEE MEMBER

---

RAY HOLLIDAY | STUDIO PROFESSOR

# TABLE OF CONTENTS

01 RESEARCH

02 SITE

03 CONCEPT

04 MATERIALS

05 DESIGN

06 CLOSING

07 REFERENCES





THE  
THREE  
SISTERS





## ABSTRACT

The Three Sisters is a Native American agriculture practice that dates back to the indigenous times of America. This agriculture practice includes three vegetables: corn, beans, and squash. These three vegetables are grown together because they naturally support themselves. Corn provides the structure for the beans to grow on, squash prevents weeds, and the beans give specific nutrients to the soil required for a bountiful harvest. This system is naturally self-sufficient, and it works. The idea behind The Three Sisters restaurant is to create a system that is self-sufficient on a multidimensional level. The concept of becoming self-sustaining from an architectural perspective allows us to look into so many levels of the design from a new perspective.

**THE THREE SISTERS IS A SYMBIOTIC  
AGRICULTURAL RELATIONSHIP. HOW  
CAN THE SAME NOTION OF THAT  
RELATIONSHIP BE REFLECTED IN  
ARCHITECTURE?**









## RESEARCH



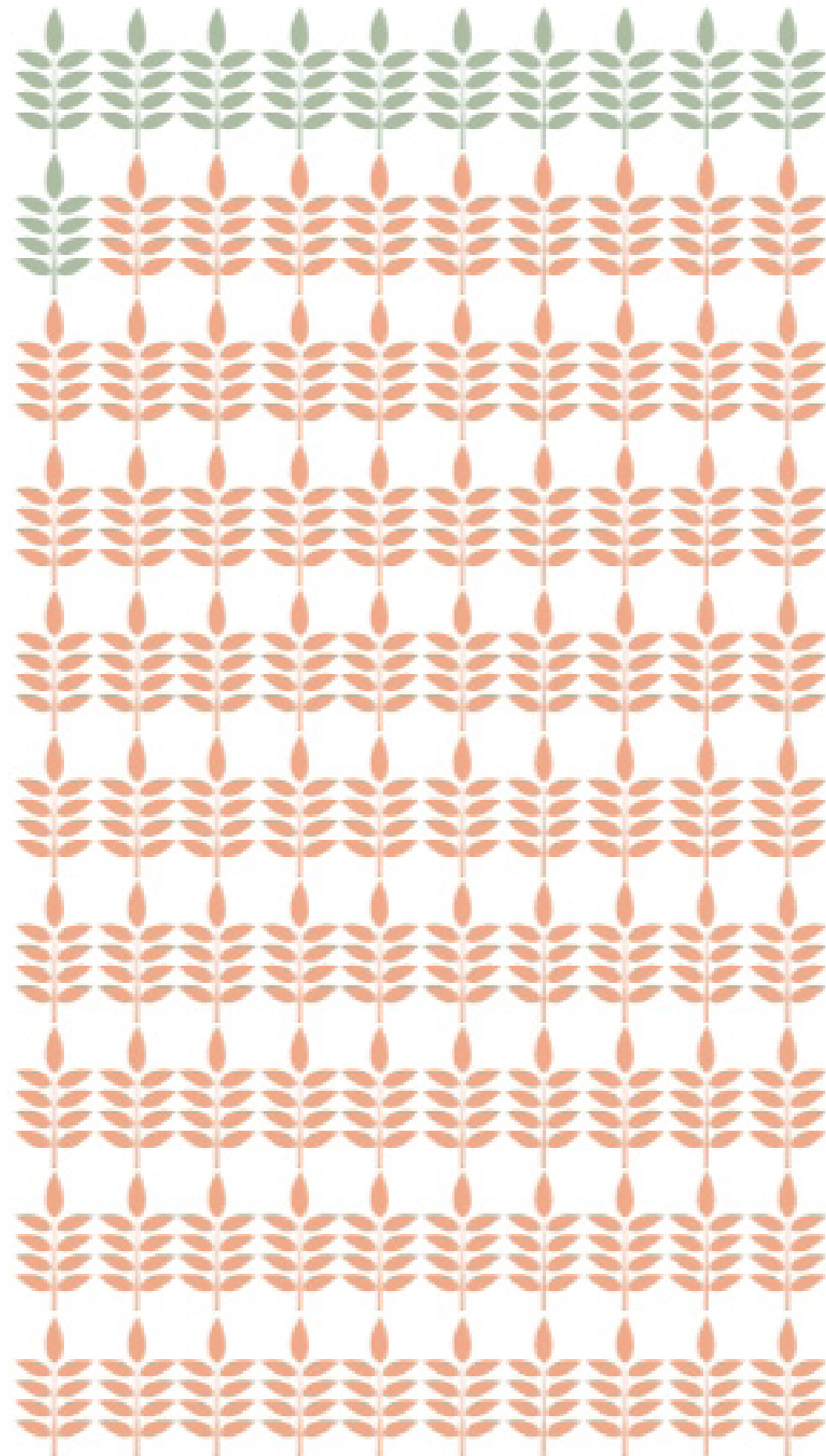

## RESEARCH

Food deserves a platform that is more significant than its current place in society. Today we are known to be in a “fast-food culture.” Fast food doesn’t just mean fast-food restaurants; it also is regarding our need for instant gratification. We live in a world now where you can get your groceries delivered to your door, enjoy chef-inspired meals in just 90 seconds, and an entire meal comes to you in the form of a drink. People have entirely forgotten where their food comes from and how it is grown. The degree of separation from the earth to the food on your plate is the largest it has ever been. One of the fascinating things discovered in my research is the percentage of the variety of food we sell in stores. In everyday grocery stores, we only see about 11 percent of the array of products that exists in the world. For example, if I were to ask you to picture a piece of corn, you would imagine the conventional yellow corn possibly even still in its green husk. Yet that is just one strain of corn, while there are hundreds of different varieties of corn ranging from all different colors and flavors. The further the degree of separation from soil to plate also decreases the variety of fruit and vegetable produce.





## WHERE FOOD MEETS ARCHITECTURE

The Three Sisters restaurant aims to decrease the degree of separation of soil to plate by using a symbiotic relationship of architecture, chefs, and agricultural education. Space is designed to heighten the senses and show the process of seed, product, to plate. The consistent theme of threes can be seen in the three main buildings based on the three main programs growing, cooking, and eating. The material selection has three primary materials that are constant throughout the entire project; glass, corten steel, and Texas limestone.





SITE

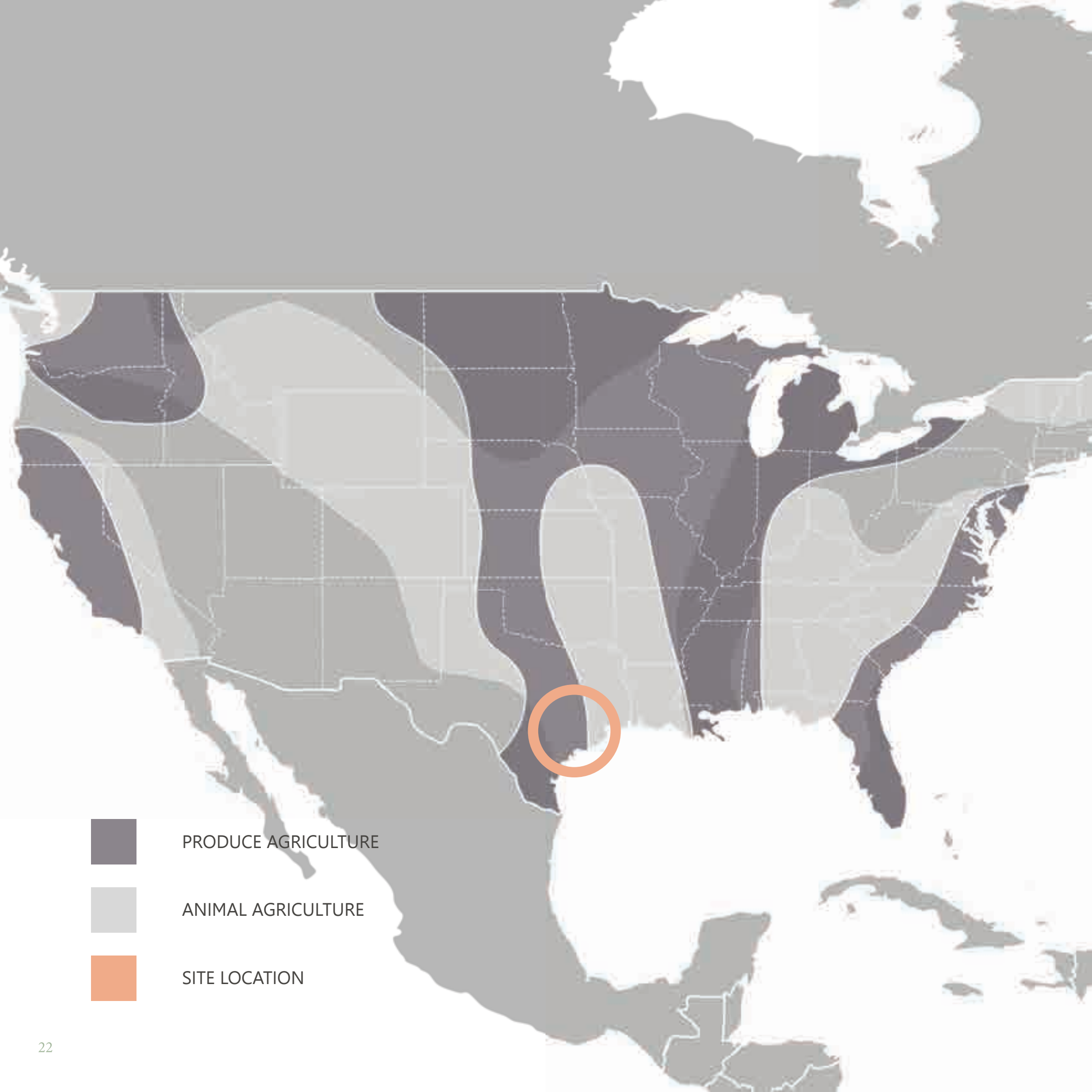



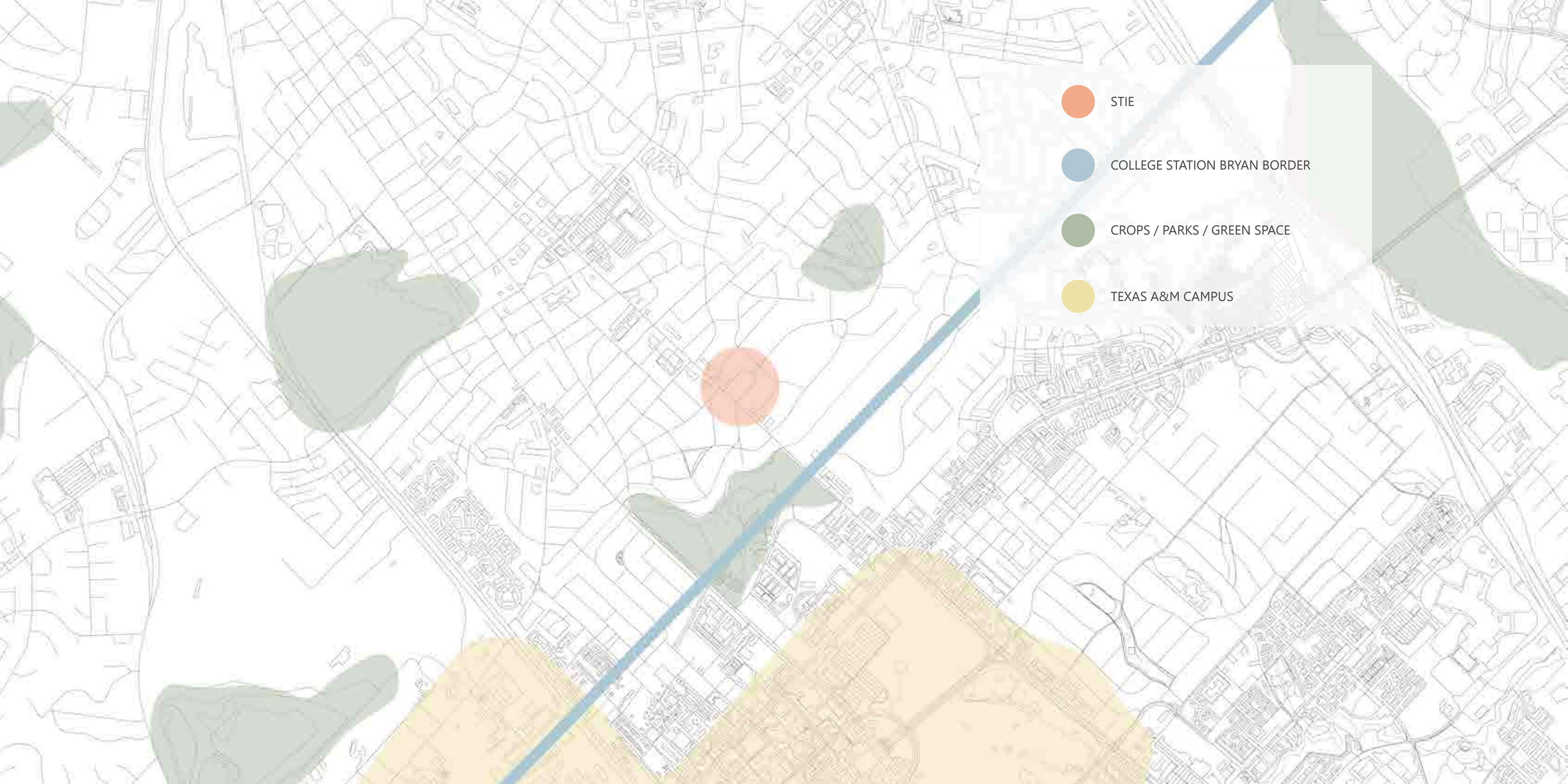

STIE



COLLEGE STATION BRYAN BORDER



CROPS / PARKS / GREEN SPACE



TEXAS A&M CAMPUS





- A. ENTRANCE
- B. RESTAURANT
- C. RESTAURANT KITCHEN
- D. ON SITE TEST GARDEN
- E. GREEN HOUSE AND NURSERY
- F. STORAGE
- G. AGRICULTURE BUILDING
- H. TEST KITCHEN
- I. N. GARDEN ACRES BLVD.
- J. S. GARDEN ACRES BLVD.
- K. TEXAS AVE.
- L. EDGEMORE DRIVE



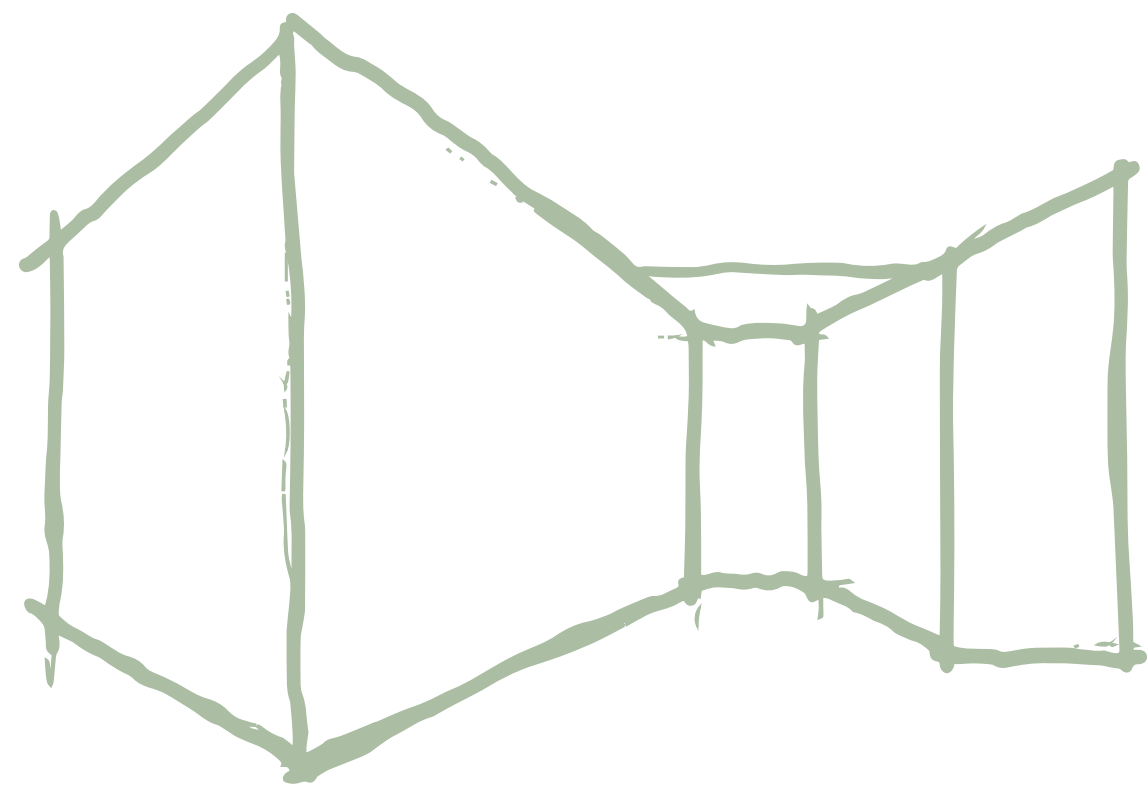

CONCEPT







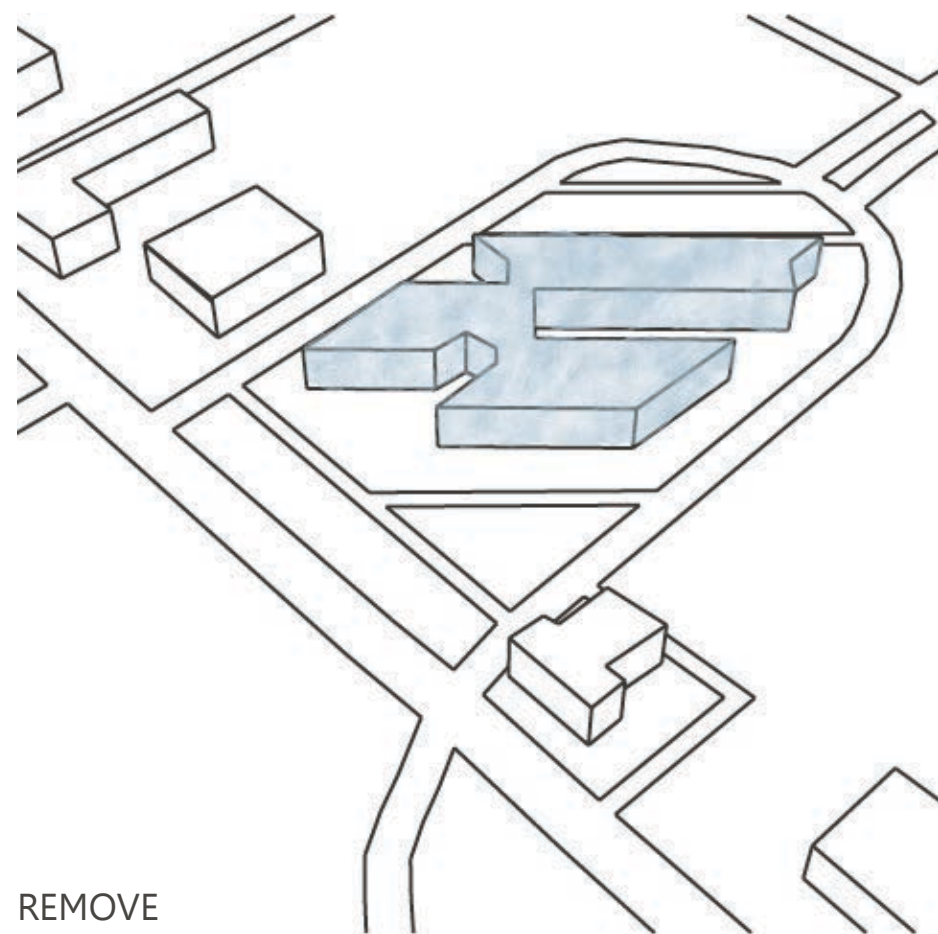

REMOVE

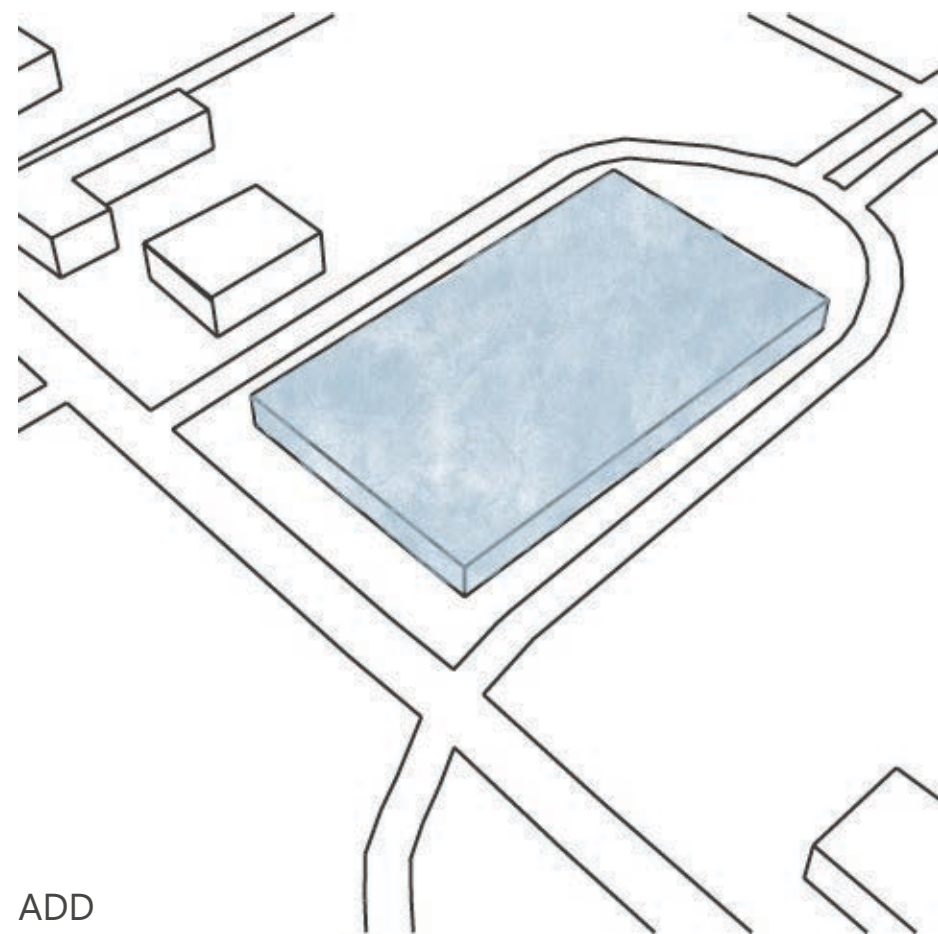

ADD

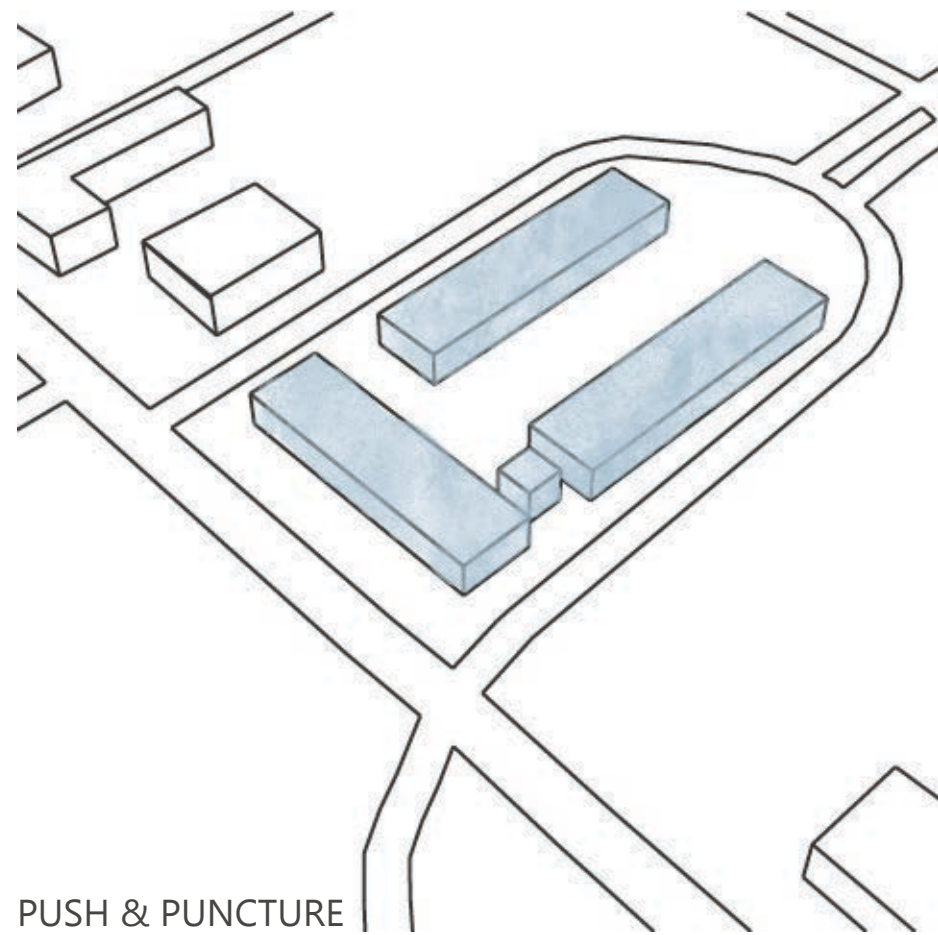

PUSH & PUNCTURE

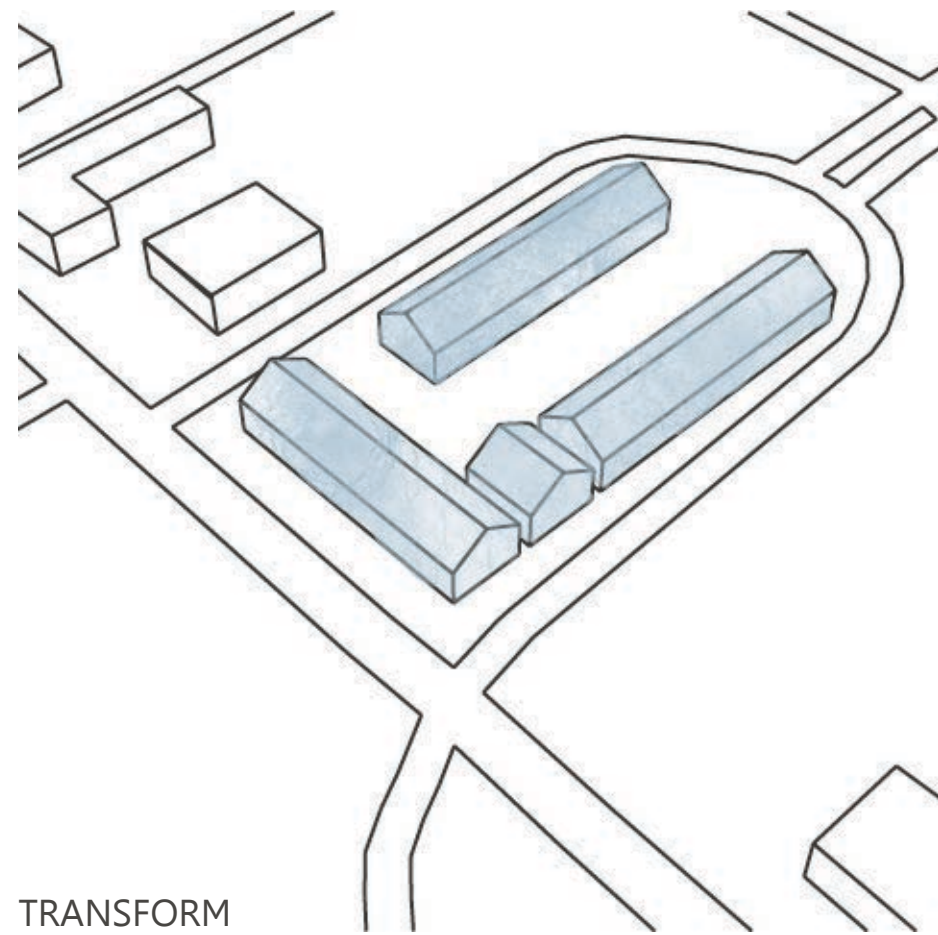

TRANSFORM



GROWING

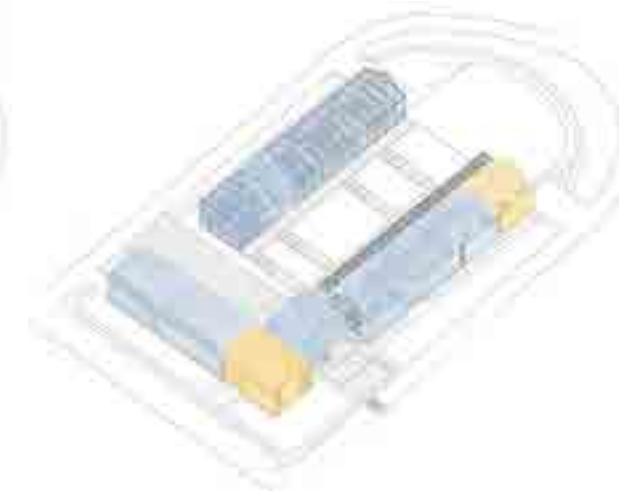

COOKING

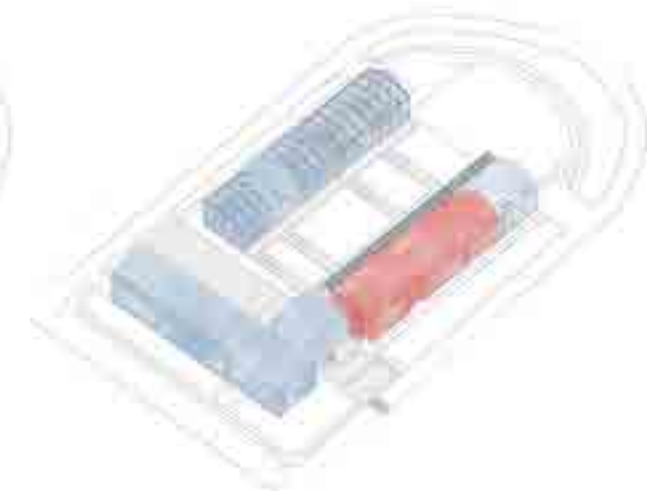

EATING



25,000 sqft

5,000 sqft

10,000 sqft





## THICKENING THE WALLS

The idea of thickening the wall using Texas limestone was a choice made to represent the area through materials. It also created the opportunity for the wall to be inhabited by the user. Moments of in the Limestone wall are broken, turned, or indented to create spaces for the individual experience.

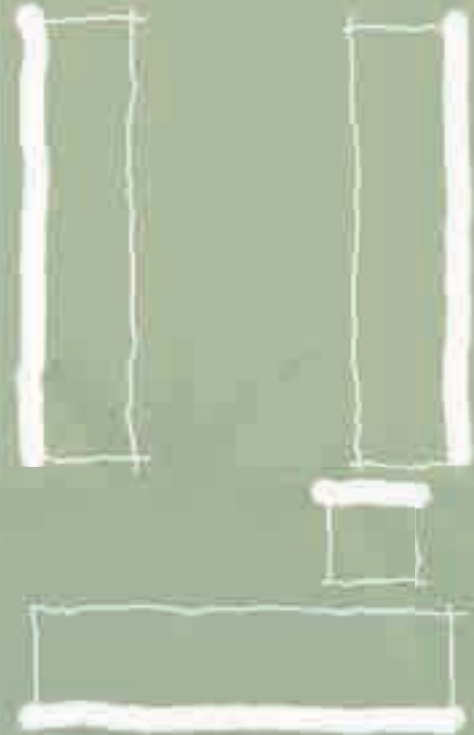





## PERMANENCE VS. TEMPORARY

Architecture in modern design will withstand a hundred years or so. Often before the one hundred year mark is met, renovations or updates are required due to technological advancements. The Three Sisters combine the beauty of "permanent" architecture with the innovation and ability to change. The four primary walls of limestone are the permanence, the adjacent walls to them are not. The corten steel and glass structures are designed to be redesigned. The concept of creating a design that is both permanent, and temporary came to me while cooking. Much like a recipe passed down through the generations of a family, it too will be manipulated and changed. Yet the recipe still passes down, creating a permanent place for it in time.

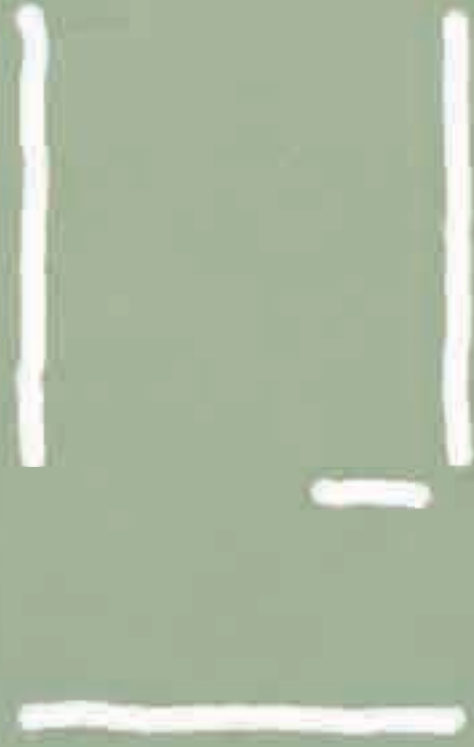





## SITE AXIS

The Texas limestone walls are organized in a horseshoe shape to create a courtyard. The goal is the design always has the essence of the original project even after it has changed. If the project was stripped to its core attributes, the courtyard and the site axis are the most crucial elements. The reason for this is because they will connect and inspire future urban developments as the area gentrifies.

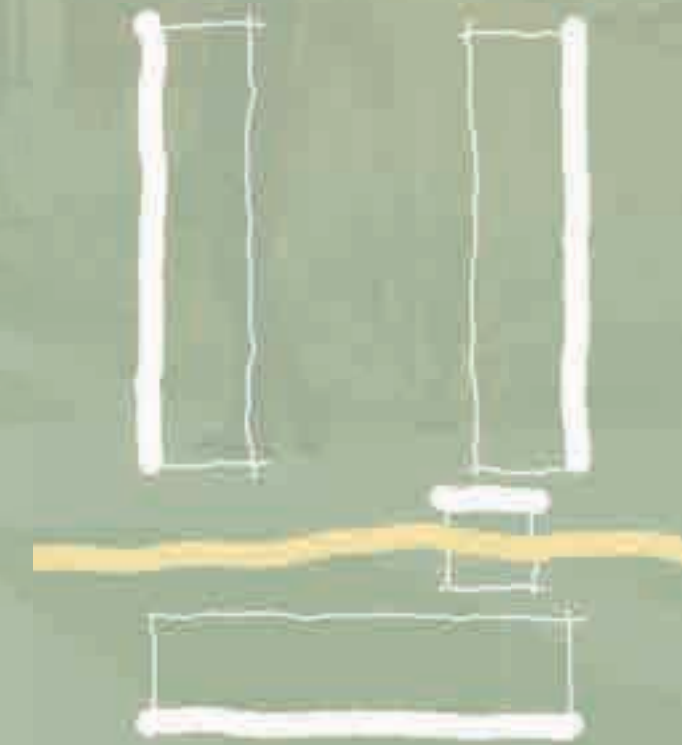



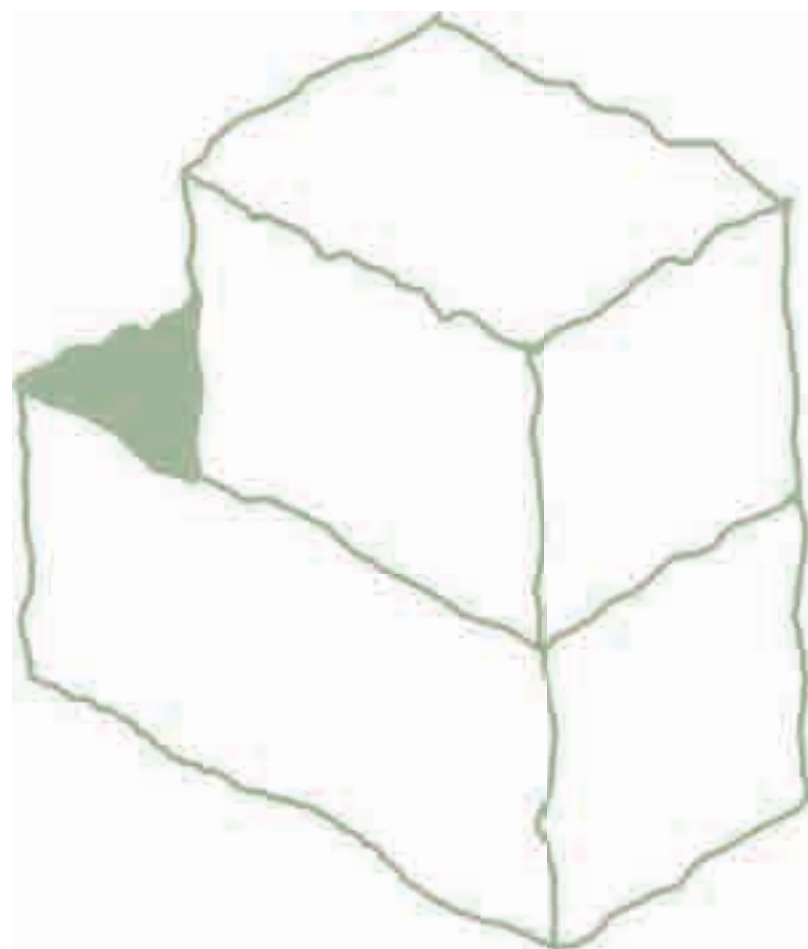

## MATERIALS



# WALL AXONOMETRIC

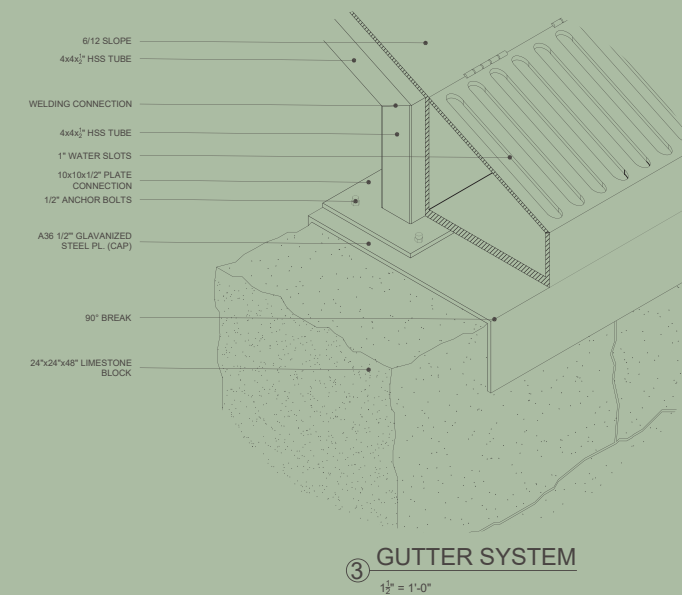
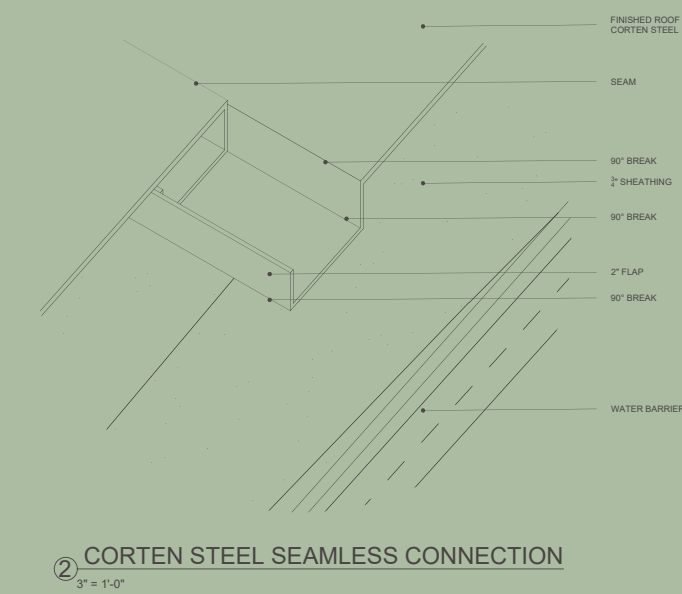
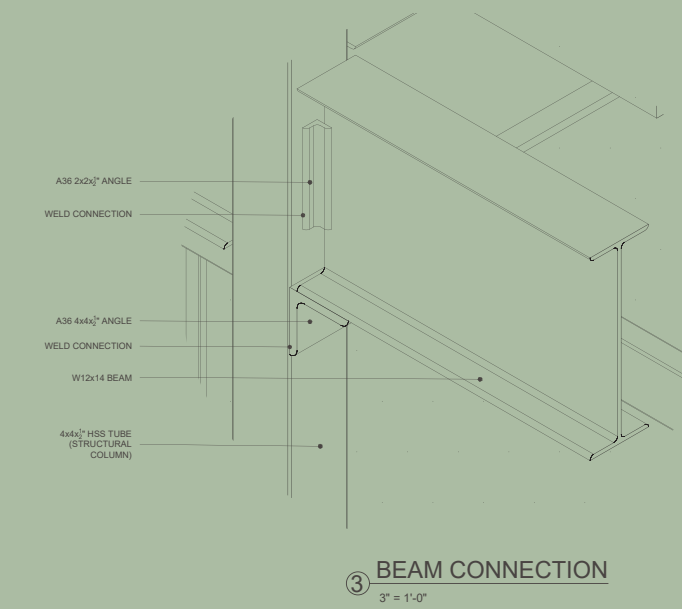
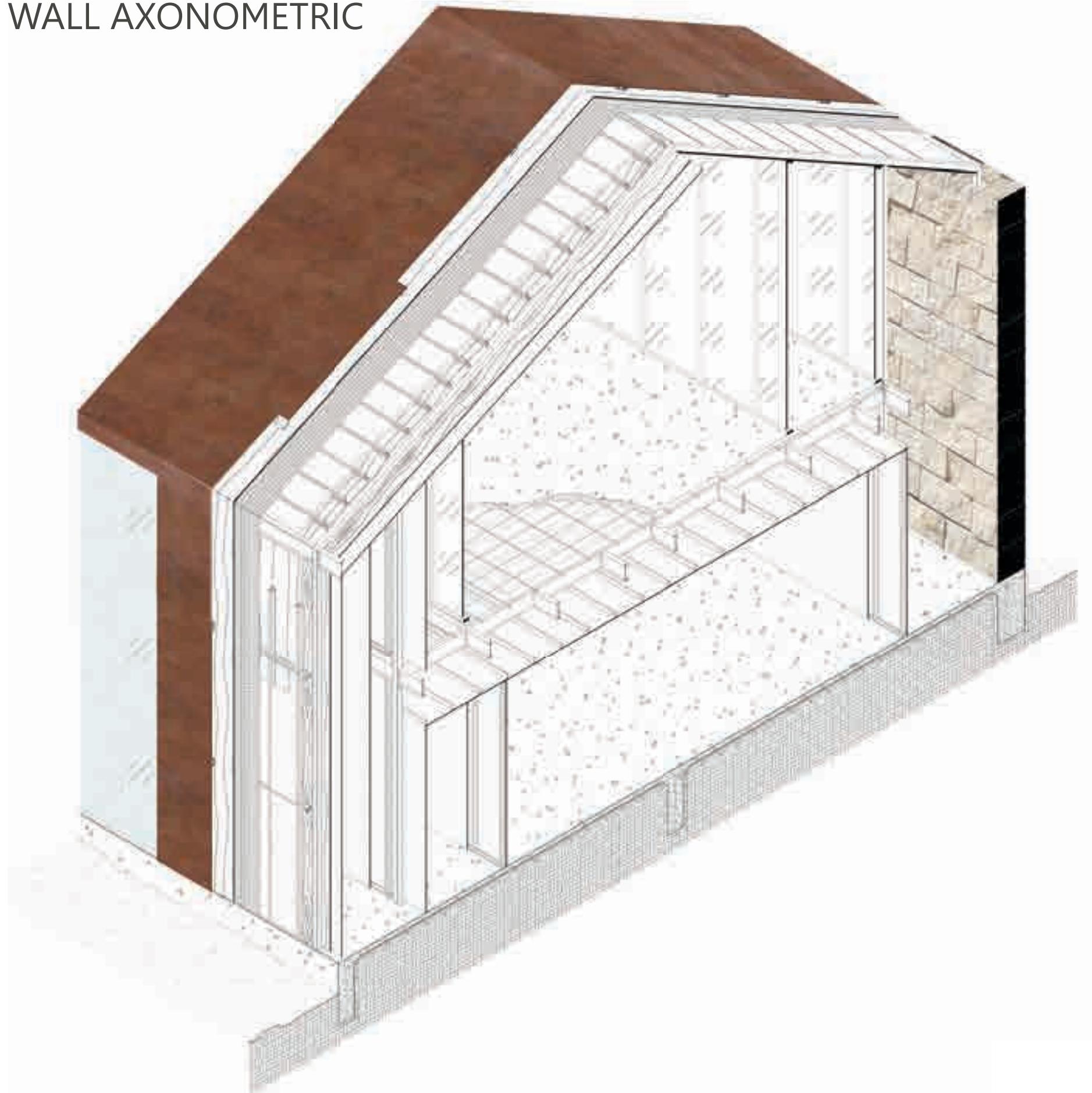



EXPLODED AXONOMETRIC

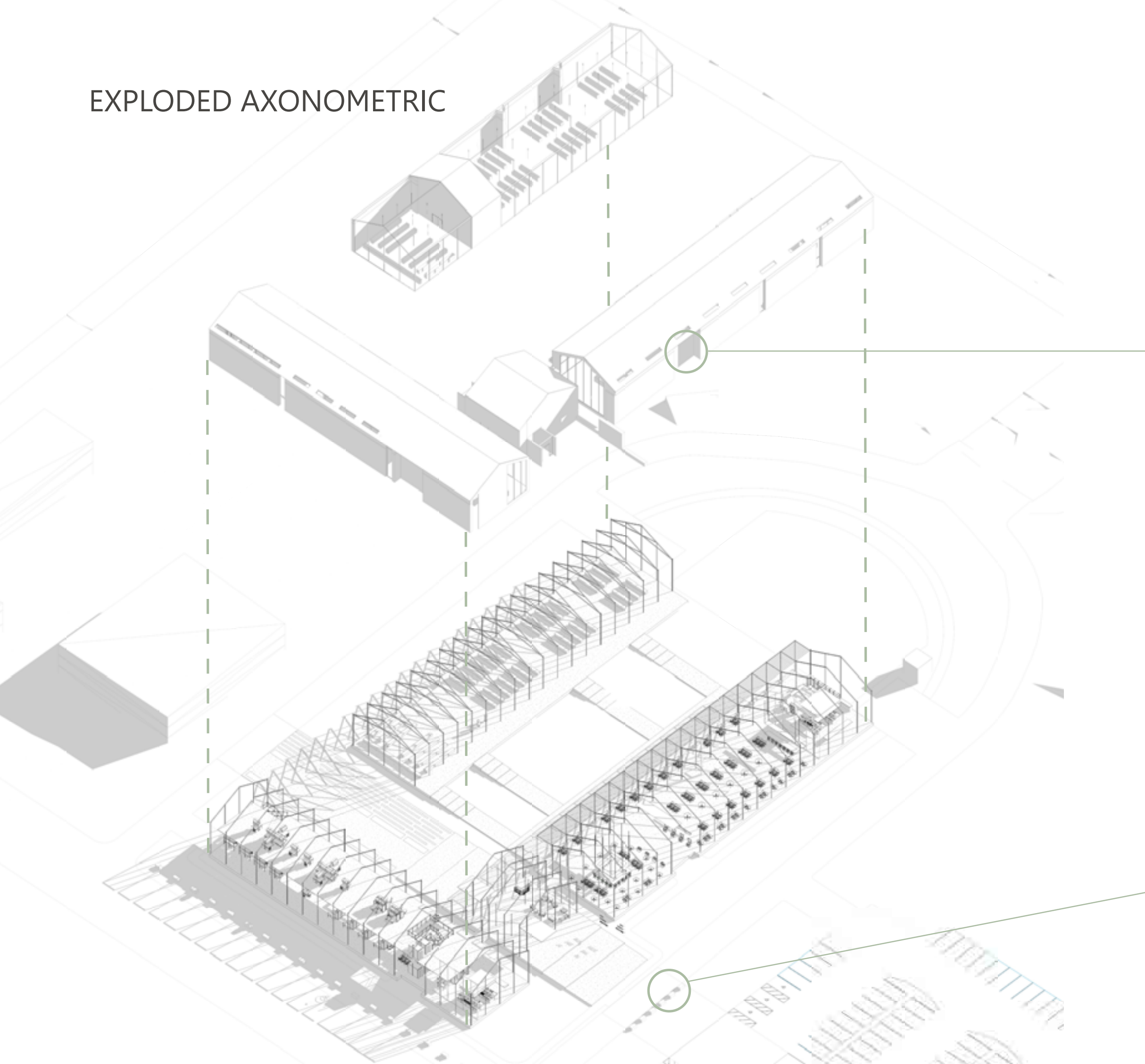



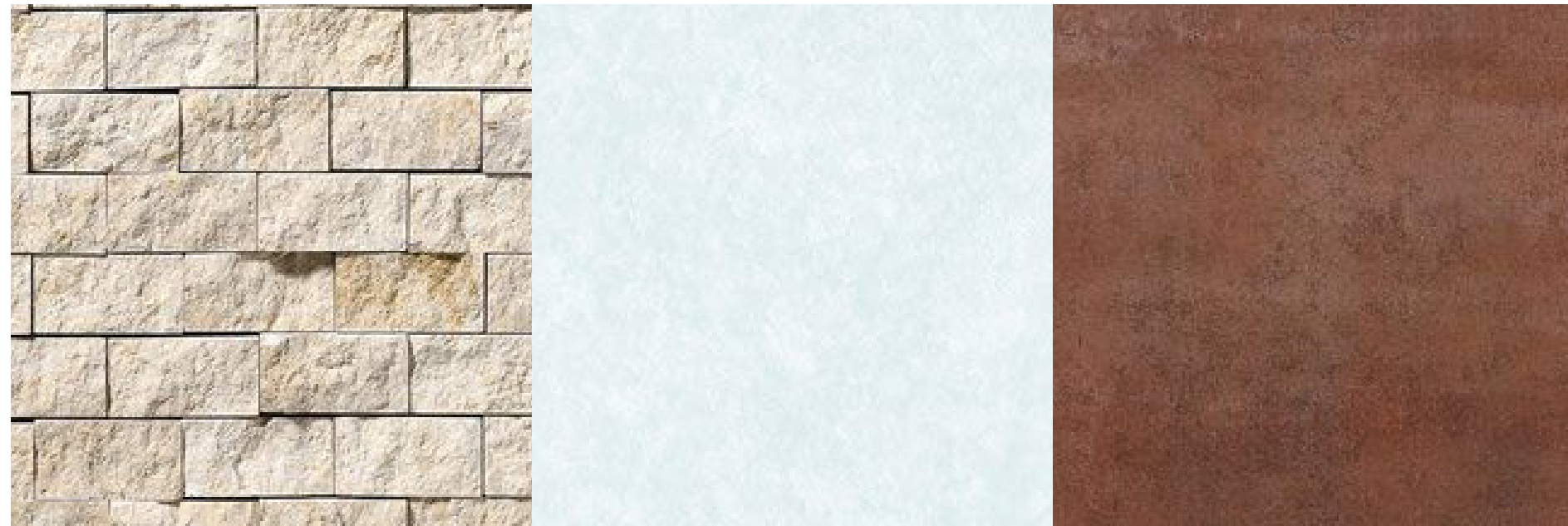

## MATERIALS

Texas Limestone, Glass, and Corten steel are the three primary materials that are consistent throughout the project. Each element represents one of The Three Sisters. The limestone is the structure or the corn of the project allowing the glass and corten steel are the beans and squash that complete the symbiotic relationship. The glass supports the building with natural light. While the Corten steel panels balance out the materials with its vibrant red earth like tones.





ELEVATION 01 - SOUTH



ELEVATION 02 - WEST





ELEVATION 03 - NORTH



ELEVATION 04 - EAST



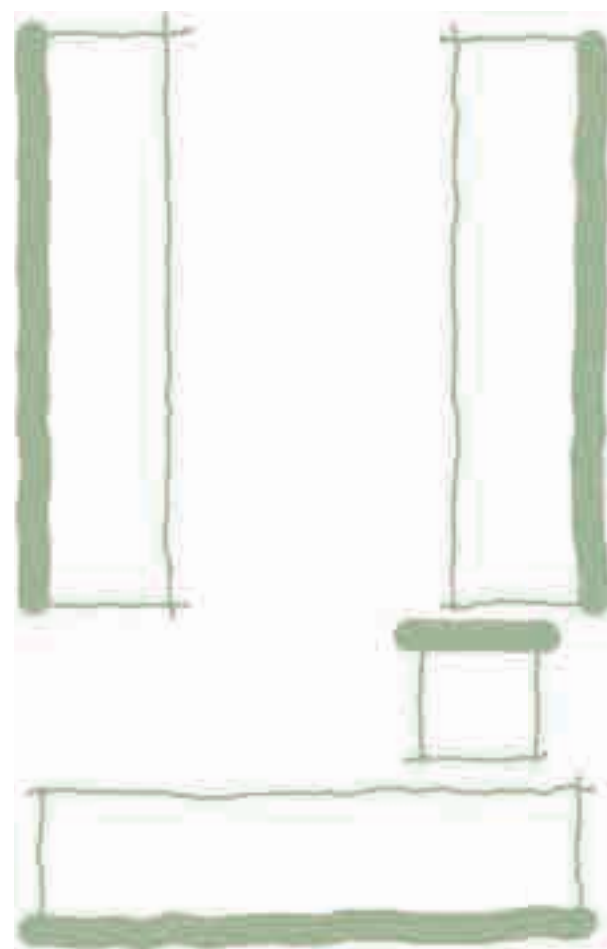

## DESIGN



FIRST FLOOR

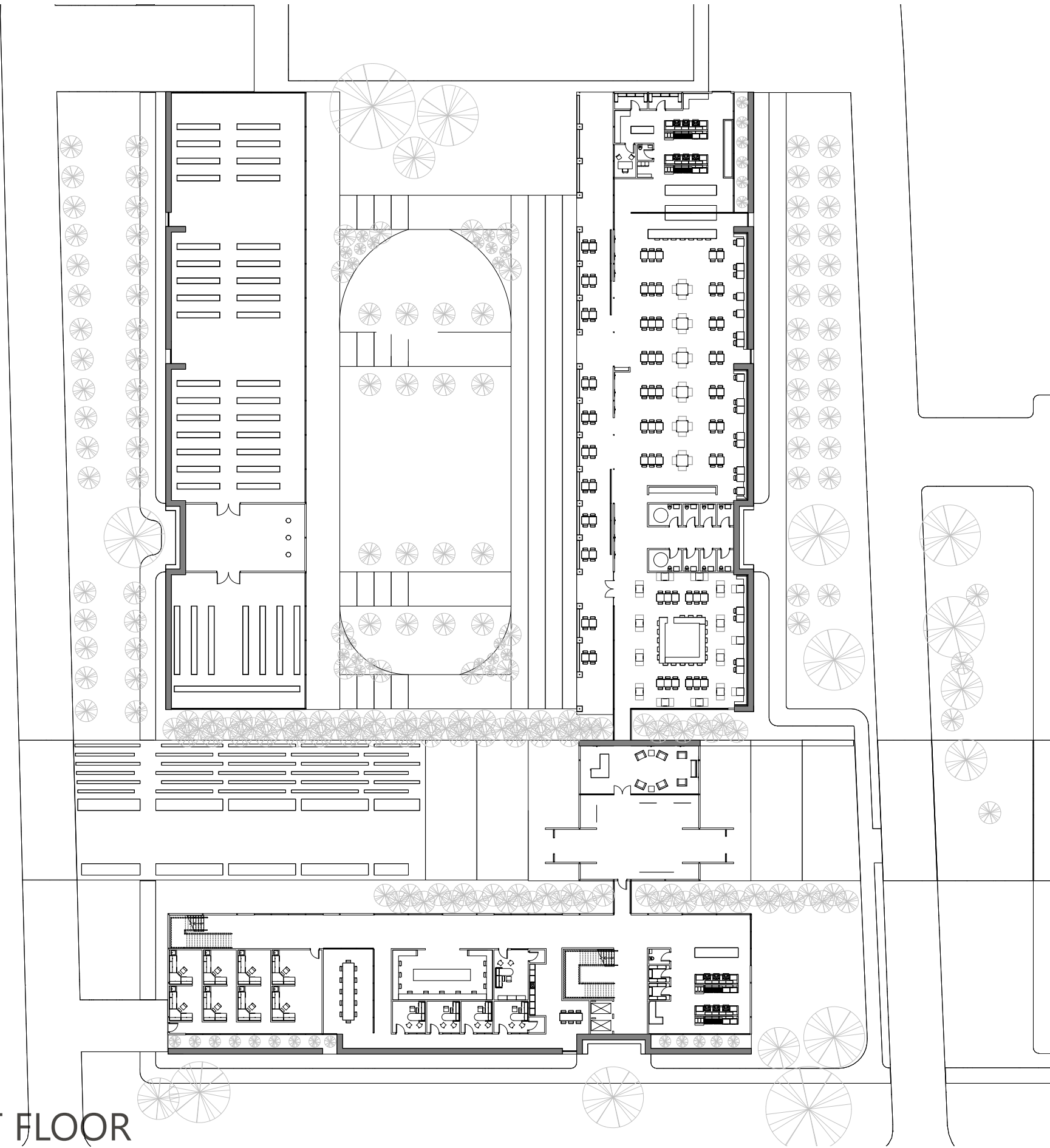

SECOND FLOOR

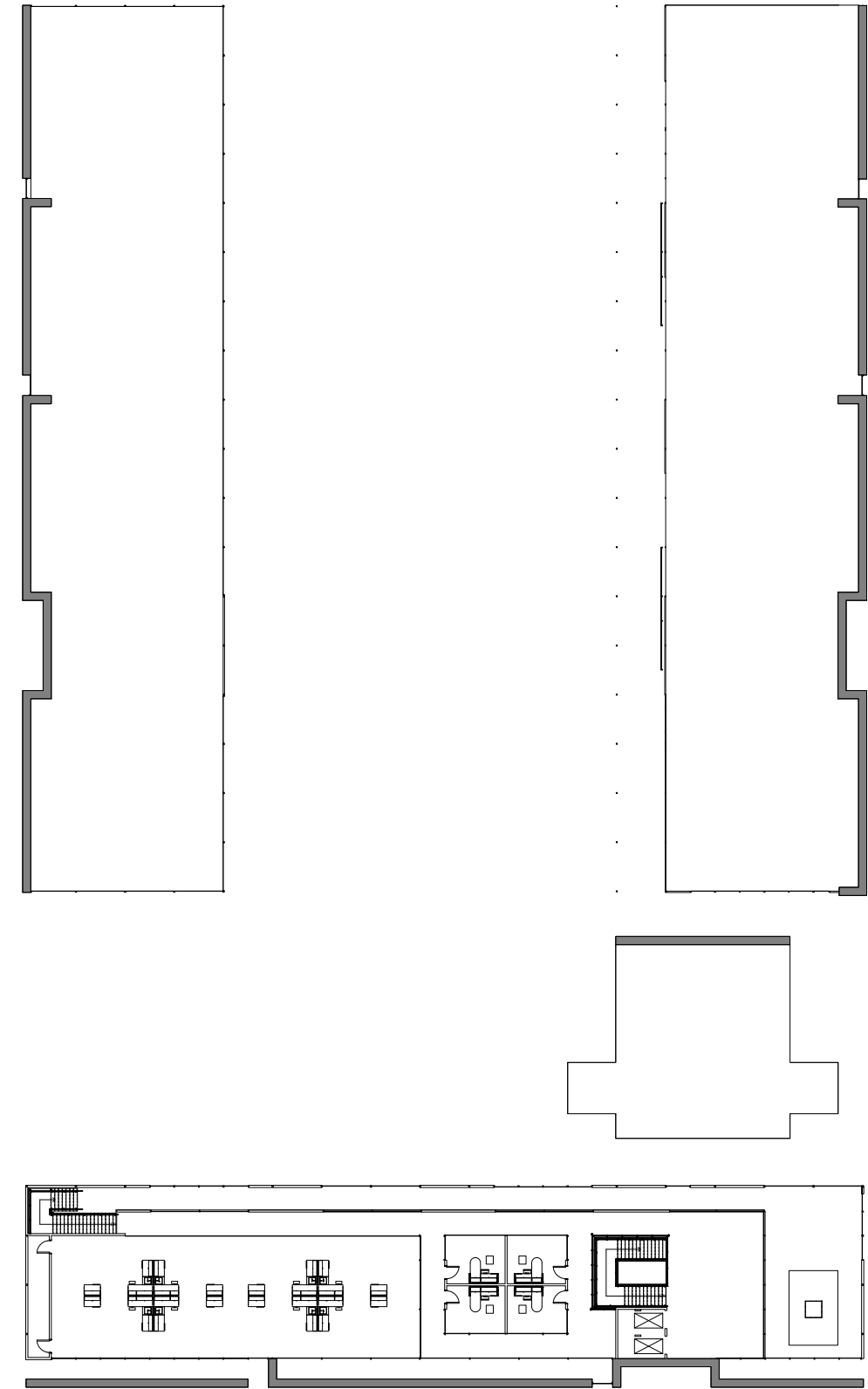





**BUILDING ONE  
ENTRANCE**

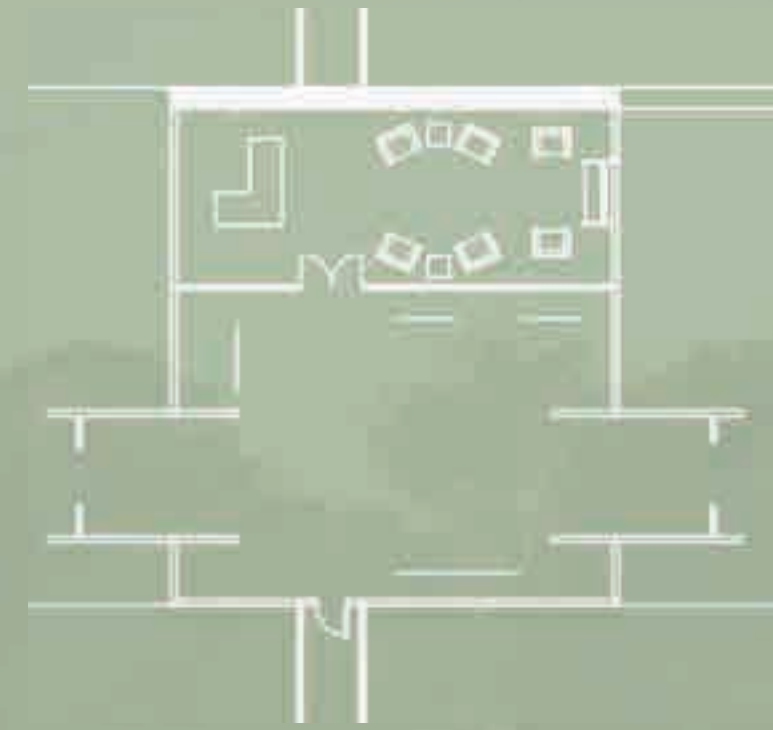









**BUILDING TWO  
BAR, RESTAURANT & KITCHEN**

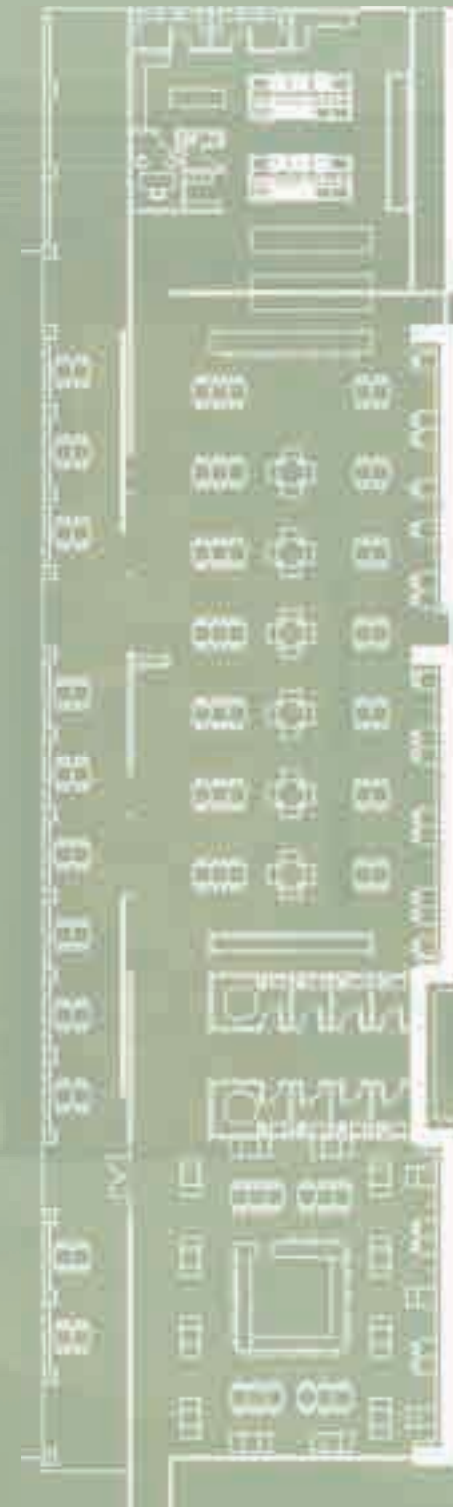

















**BUILDING THREE  
GREEN HOUSE**









**BUILDING FOUR  
TEST KITCHEN, AGRICULTURE  
OFFICES, AGRICULTURE LAB**





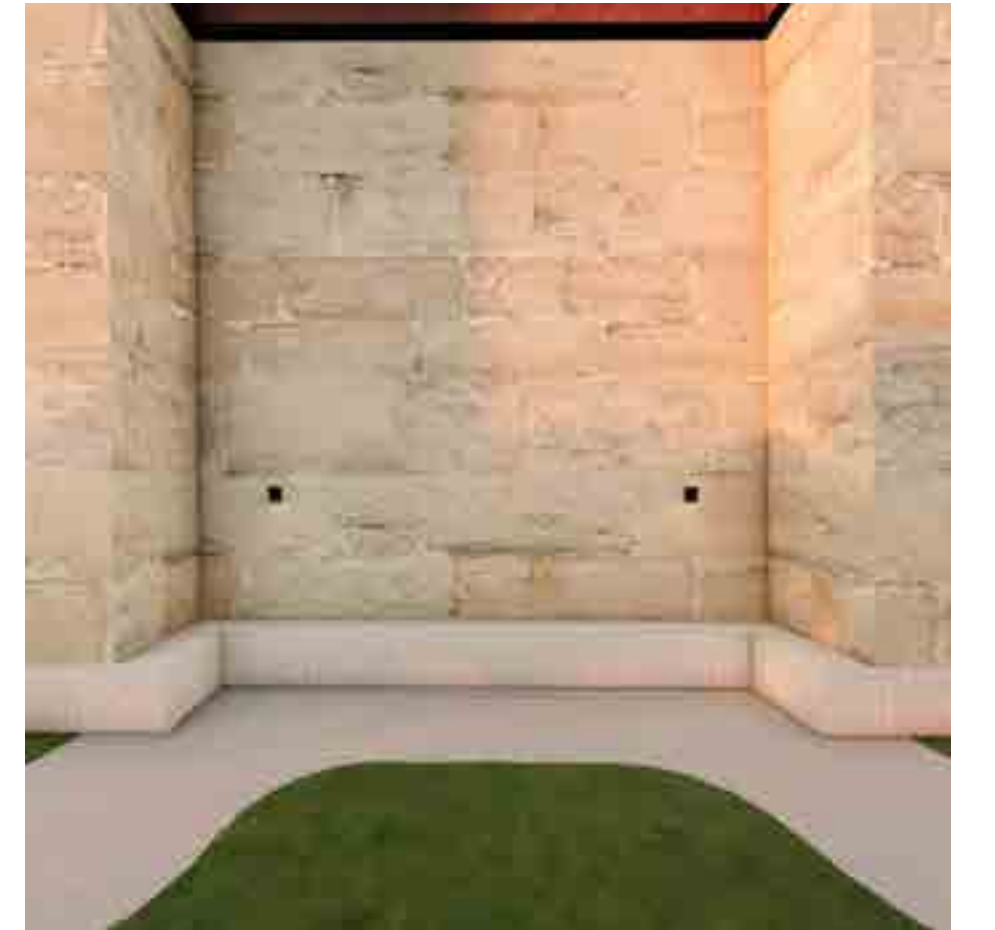













## CLOSING REMARKS

The greatest thing an architect can do when amongst designing is to become the user and experience the space before it is even imagined. This project was my reality for almost a year, but it took a lifetime to create. I drew inspiration from my experiences while combining it with the research I found and was passionate about throughout graduate school. I don't know if my project solves the overall issue of educating the public about food. I do, however, think it sets up the questions that need to be asked about food, food culture, and the aspects of good farming practices. Wes Jackson states, "If you are thinking about an idea that you can solve in your lifetime, you're thinking too small." Architecture is not about solving the problems of today but setting up the space to allow the questions of tomorrow.





## REFERENCES

"Chefs Table ." Dan Barber, season 1, episode 2, NETFLIX.

Barber, Dan. The Third Plate: Field Notes on the Future of Food. Abacus, 2016.

"SALT FAT ASID HEAT." NETFLIX, season 1, episode 1-4

Cruickshank, Dan, and Dan Cruickshank. Architecture: a History in 100 Buildings. William Collins, an imprint of HarperCollins Publishers, 2019.

Botton, Alain De. The Architecture of Happiness. Penguin Books, 2014.

Kassie, et al. "Interdependence in Farmer Technology Adoption Decisions in Smallholder Systems: Joint Estimation of Investments in Sustainable Agricultural Practices in Rural Tanzania." AgEcon Search, 1 Jan. 1970, [ageconsearch.umn.edu/record/126791/](http://ageconsearch.umn.edu/record/126791/).

Garvin, David F, et al. "Historical Shifts in the Seed Mineral Micronutrient Concentration of US Hard Red Winter Wheat Germplasm." Wiley Online Library, John Wiley & Sons, Ltd, 16 Aug. 2006, [onlinelibrary.wiley.com/doi/abs/10.1002/jsfa.2601](http://onlinelibrary.wiley.com/doi/abs/10.1002/jsfa.2601).







