

THE REMEMBRANCE

AT GEORGE FLOYD SQUARE

The rising number of filmed overt police brutality has fueled social tensions, revolt, and a desire for police and racial justice reform. In the past two years alone, the media has been bombarded with photos of unarmed people of color killed by law enforcement or white vigilantes. The deaths of George Floyd, Rayshard Brooks, Breonna Taylor, Daniel Prude and countless others are yet another example of discrimination against people of color and the latest chapter in the history of racial injustice.

The very public murder of George Floyd as he plead for his life sparked both indignation and outrage at the institutionalized systemic failures regarding race and inequality that have permeated the United States from its inception. Protests, riots, and an uprising of the community standing in solidarity with people of color inspired not only an American movement, but a global one as people of all races, genders and creeds took to the streets as an act of civic engagement.

Preserving the memory of George Floyd and the thousands of unarmed people of color is the core objective of this living memorial, which acts a creative expression of pain and hope. In bringing these historical events into a discussion with the function of architecture and civic design principles, I looked at how the built environment can act as a stage for local and communal exchange of ideas and experiences in regards to people, history and culture.



2022

MONÉT HALL

THE REMEMBRANCE

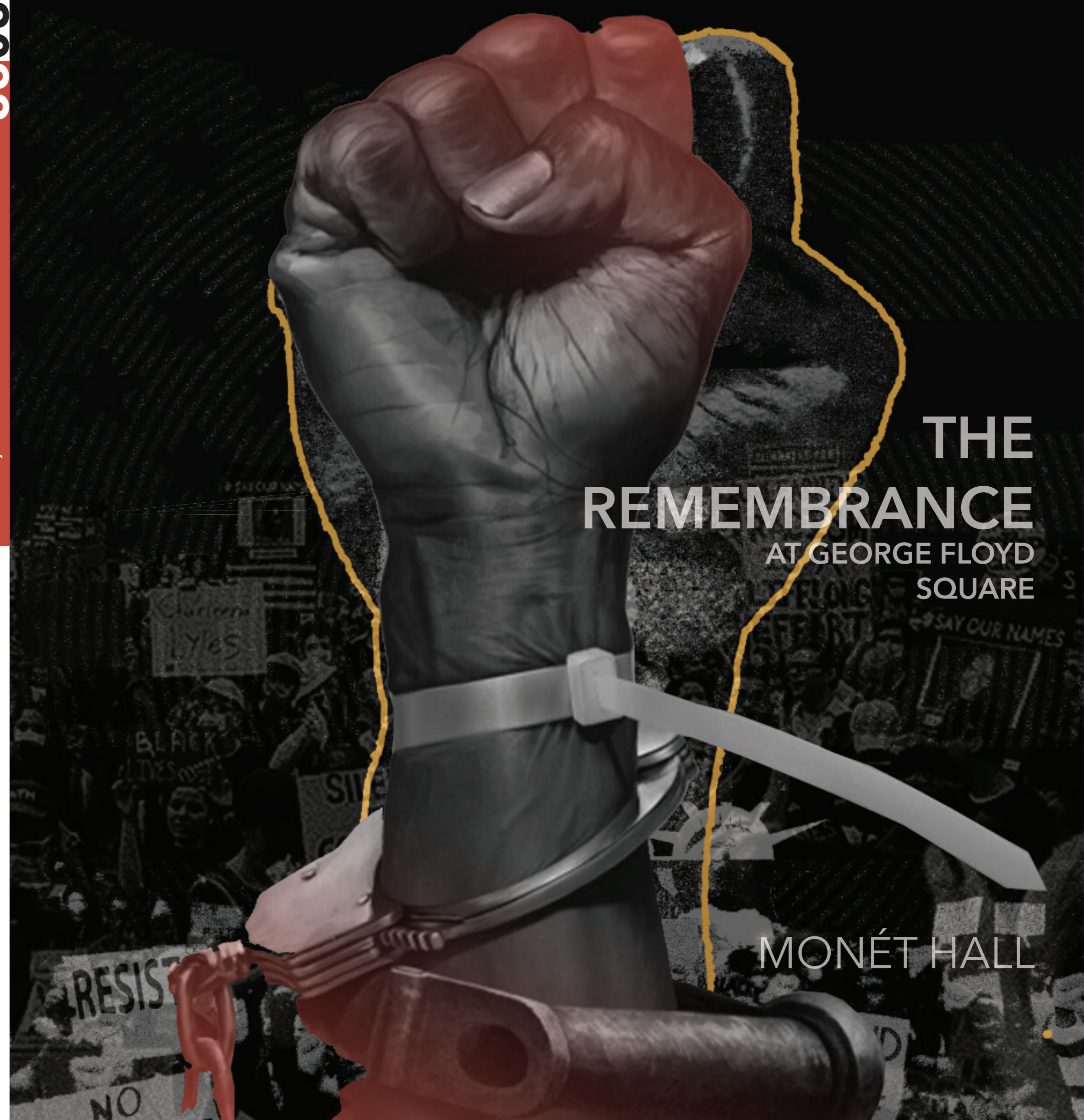

THE REMEMBRANCE

AT GEORGE FLOYD SQUARE

MONÉT HALL



THE REMEMBRANCE

AT GEORGE FLOYD SQUARE

MONÉT HALL





BRUTALITY

[NOUN]

POLICE BRUTALITY

[ADJ]

1. Suitable to one who lacks intelligence, sensitivity, or compassion befitting a brute, this includes:
 - a: CRUEL
 - b: HARSH
2. Police brutality is the excessive and unwarranted use of force by law Enforcement. It is an extreme form of police misconduct or violence end is a civil rights violation. It also refers to a situation where officers exercise undue or excessive force against a person.
 1. Excessive force
 2. Wrongful Search and Seizure
 3. Racial Discrimination
 4. False Arrest or Wrongful Imprisonment

ABSTRACT

The rising number of filmed overt **police brutality** has fueled social tensions, **revolt**, and a desire for police and racial justice reform. In the past two years alone, the media has been bombarded with photos of unarmed people of color killed by law enforcement or white vigilantes. The deaths of George Floyd, Rayshard Brooks, Breonna Taylor, Daniel Prude and countless others are yet another example of **discrimination** against people of color and the latest chapter in the history of **racial injustice**.

The very public murder of George Floyd as he plead for his life sparked both indignation and outrage at the institutionalized systemic failures regarding race and **inequality** that have permeated the United States from its inception. Protests, **riots**, and an **uprising** of the community standing in solidarity with people of color inspired not only an American movement, but a global one as people of all races, genders and creeds took to the streets as an act of **civic engagement**.

Preserving the memory of George Floyd and the thousands of unarmed people of color is the core objective of this living memorial, which acts a creative expression of pain and hope. In bringing these historical events into a discussion with the function of architecture and civic design principles, I looked at how the built environment can act as a stage for local and communal exchange of ideas and experiences in regards to people, history and culture.



FROM PAST TO PRESENT



1954

Marching For A Change

Concepts of police brutality, bigotry and racism have been the catalyst for many race riots since the 1950's.

Civil Rights Act of 1964

Discrimination on the basis of race, color, sex, religion, national origin [and later sexual orientation and gender identity] has been outlawed in the United States since the 1960's. However, today more than 78% of U.S. citizens still have their civil rights violated.

Still Today, people of color are 2.9 times more likely to be killed by police than other races..



1985

Civil Rights Organizations

Organizations like NAACP, Kind, and Project Youth draw many of their inspiration from the 1960's civil rights and black power movement, the 1980's black feminist and womanist movement, the late -1980's political hip-hop movement, and the 2000's LGBT movement, in order to spark social reform.

Even though people of color only make up 12% of the U.S. population, we account for 27% of fatal unarmed shootings.

2014



To The Streets

On August 9, 2014, Black Lives Matter members took their grievances to the streets for the first time through the Black Lives Matter Free ride to Ferguson, Missouri. Here, they took part in a nonviolent demonstration following the murder of 18-year-old Michael Brown by police officer Darren Wilson.

2020

Three incidents in the first months of 2020, [the deaths of Ahmaud Arbery, Brunswick, Georgia -February 23; Breonna Taylor, Louisville, Kentucky - March 13; and George Floyd, Minneapolis, Minnesota; May 25] brought before the nation the continuing problem of police and vigilante murder generating huge protests, and a call for police reform across the country.

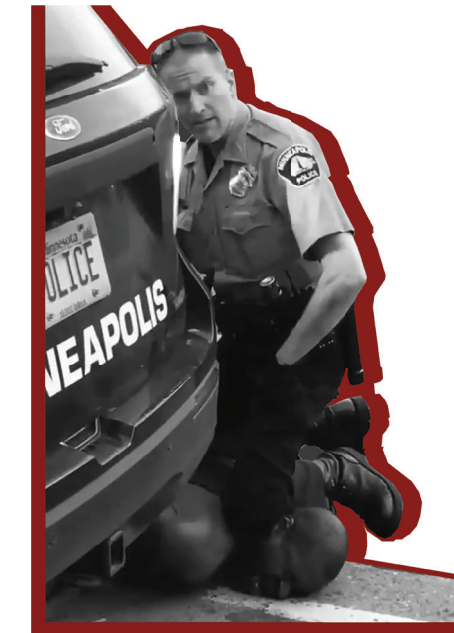

"I cant breath"
-George Floyd

Black men, who make up 12% of the male population, account for 36% of unarmed deaths

THE AVERAGE AGE OF UNARMED P.O.C DEATHS 20 - 30

Black women, who make up 13% of the female population, account for 27% of unarmed deaths

ON WE MARCH



CIVIC UNREST



Well over 650 demonstrations of civil unrest erupted across the US following the death of George Floyd.

On May 26, 2020, local protests against the killing of George Floyd began, with a video of his public death circulating on social media. The 3-day riots, demonstrations, civil disobedience and general civil resistance caused more than \$500 million in damages in more than 1,500 locations, 150 buildings burned, 604 arrested, 2 dead, and Merritt public creative expression

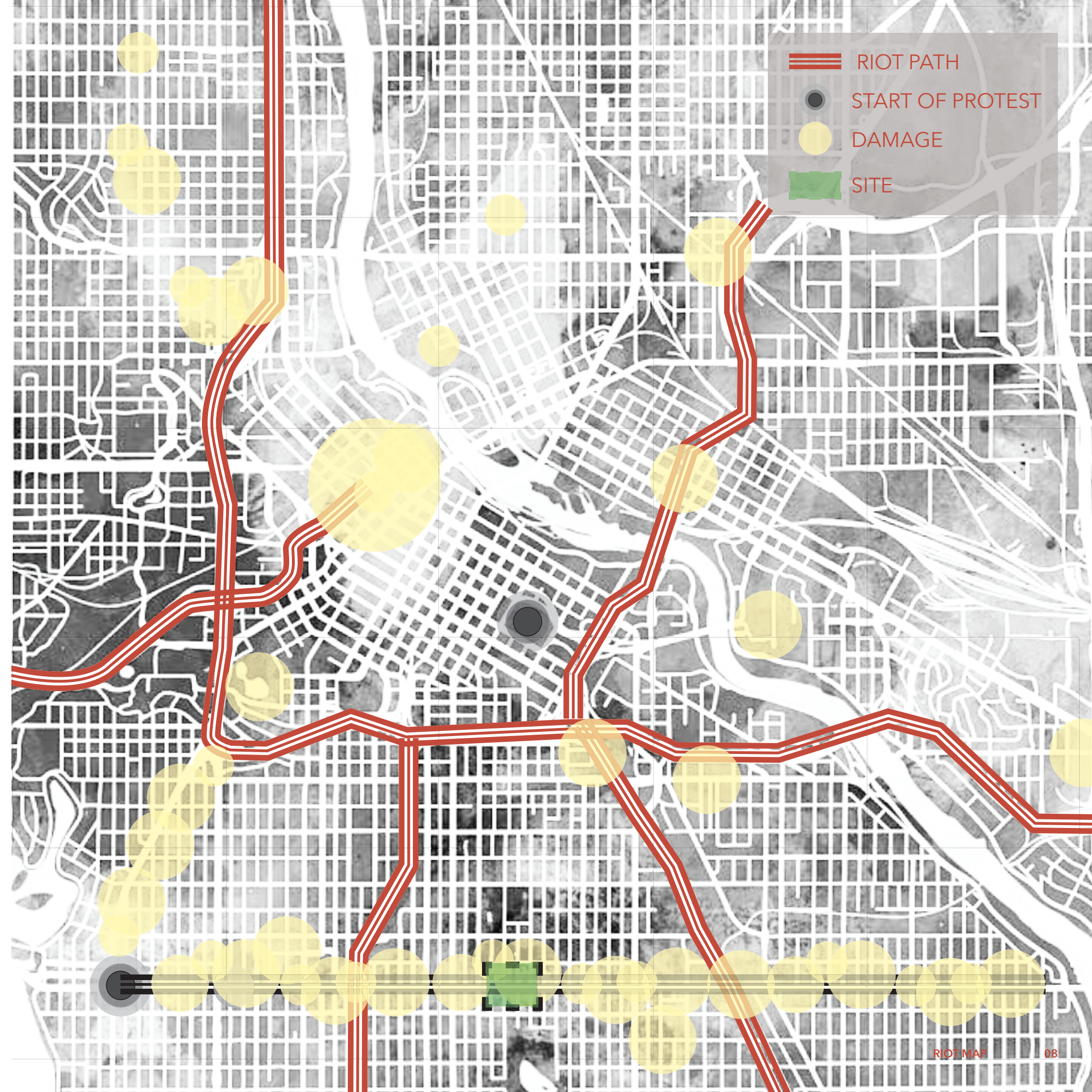

P.O.C DEMOGRAPHICS

DEMOGRAPHICS BY THE NUMBERS

41.99 MILLION
P.O.C in America

363 THOUSAND
P.O.C in Minnesota

4,500 THOUSAND
P.O.C in Powderhorn Park Neighborhood

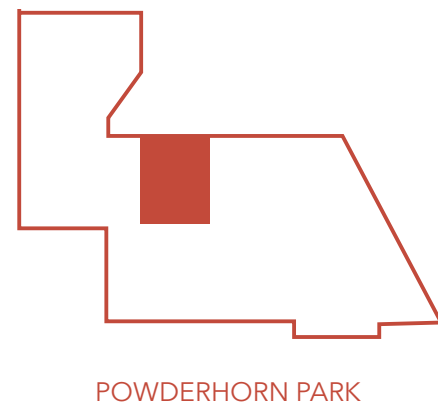
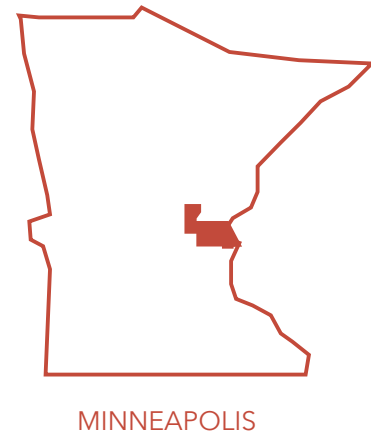

PEOPLE OF COLOR IN POWDERHORN PARK

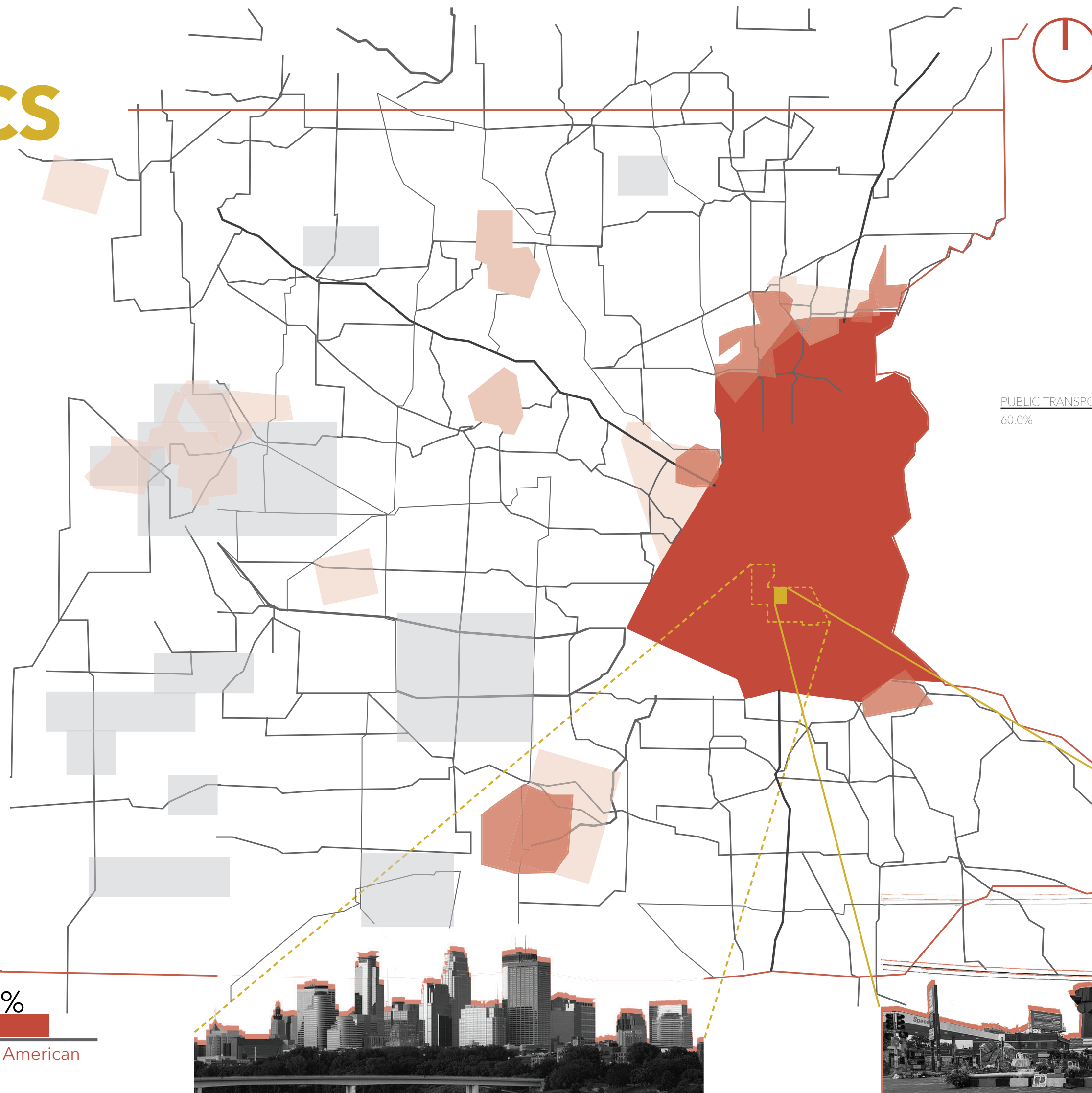
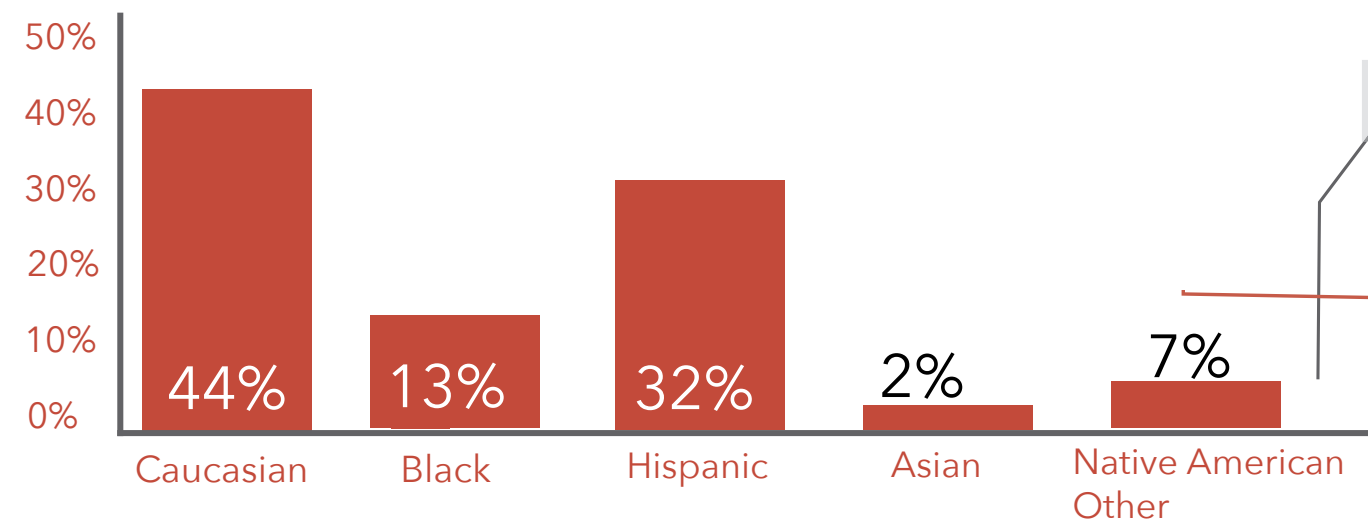

TRANSPORTATION ANALYSIS

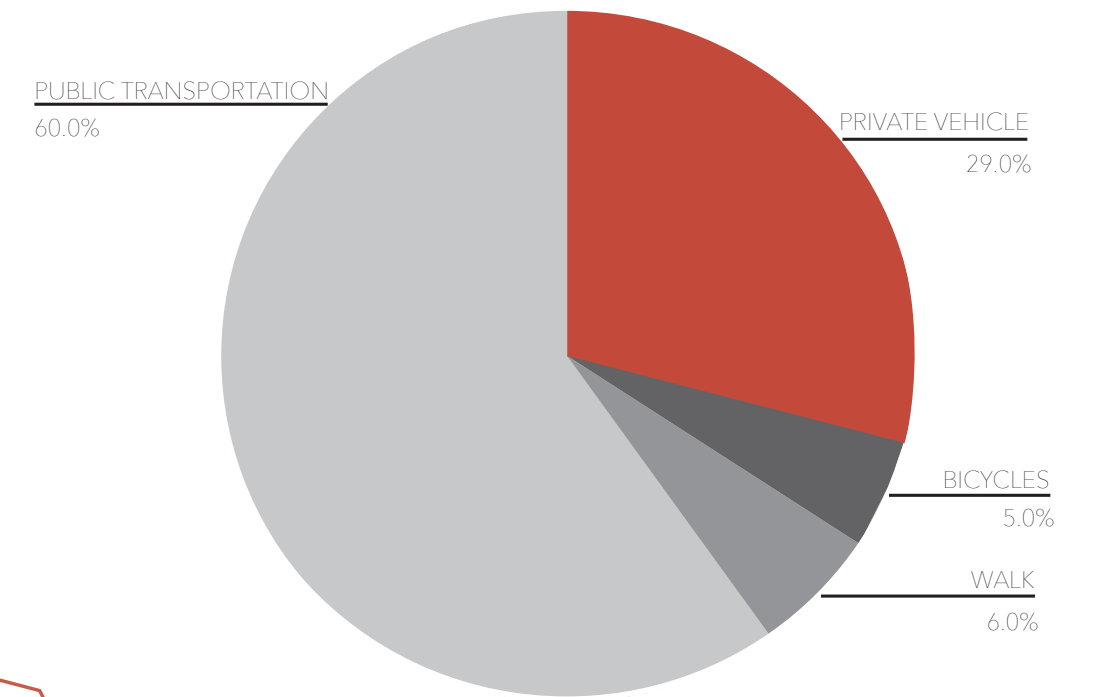

POWDERHORN PARK

The Neighborhood

Powderhorn is one of the nine wards in Hennepin County, Minneapolis, Minnesota. The Powderhorn-Park neighborhood, located in central-southern Minneapolis and roughly three miles south of downtown, has around 9,000 residents and is one of the most economically and racially diverse areas in Minnesota. According to 2020 U.S. Census statistics, 44.2% of residents are White, 32.2% are Hispanic or Latino, 13.8% are Black or African American, 4.0% identify with two or more races, 3.1% are American Indian or Alaska Native, and 2.4% are Asian or Pacific Islander.

This mostly residential area is home to 1920's style single family homes, duplexes, and three story apartment buildings with many mixed use intersections that provided a hub for local businesses and shops. For more than a century, the neighborhood has fostered a broad and lively community, sponsoring a variety of arts festivals throughout the year, among other activities and events.

Irreplaceable heritage

On May 26, 2020, the day following Floyd's murder during his arrest, a makeshift shrine appeared near East 38th Street and Chicago Avenue, and the first organized demonstrations took place. By May 27, a group of protesters had erected a temporary barricade at the intersection of East 38th Street and Chicago Avenue, while some demonstrators placed tributes near the Cup Foods shop, others spray painted "Justice for Floyd" and "Black Lives Matter" on the pavement surface. Many tourists left flowers near murals and sculptures created by activists to symbolize the Black Lives Matter movement.

The organic growth of the George Floyd memorial and increasing civil engagements across the US have created a unique opportunity where social and cultural interaction can come together and flourish. Thousands of visitors protested and grieved at the site. This creative boom in street art, engages the entire community of residents, small business owners, and the surrounding neighborhood of East 38th and Chicago Ave in a way that allows for markets, vendors and visitors an open dialogue.



EXISTING CONDITION

Today, George Floyd Square has a diverse collection of street art that is maintained by community volunteers. The protest zone spans several city blocks and is concentrated on the intersection of East 38th Street and Chicago Avenue. The four street approaches to the crossroads include welcoming entry signs and sculptures of raised fists positioned roughly two blocks distant from the main street intersection in each direction.

Various protester-installed barricades and structures marking the area's boundaries. The west boundary is at Columbus Avenue and the east boundary at Elliot Avenue. The north boundary at Chicago Avenue and East 37th Street was marked by a warming house, made of a retrofitted ice shanty. The south boundary at Chicago Avenue and East 39th Street was marked by a barricade and guard shack installed by demonstrators.

On June 20, 2021, vehicle traffic resumed to the region after more than a year. Although the protest zone remained undisturbed, the new found vehicular traffic adds an unsafe element to the visiting experience.

*"I didn't know that cutting off the street would lead us here. We didn't ask to be traumatized. We didn't plan this, we reacted and rode the wave" We will not give up this space. We will" save it for George Floyd." - Mileesha Smith
South Minneapolis resident*

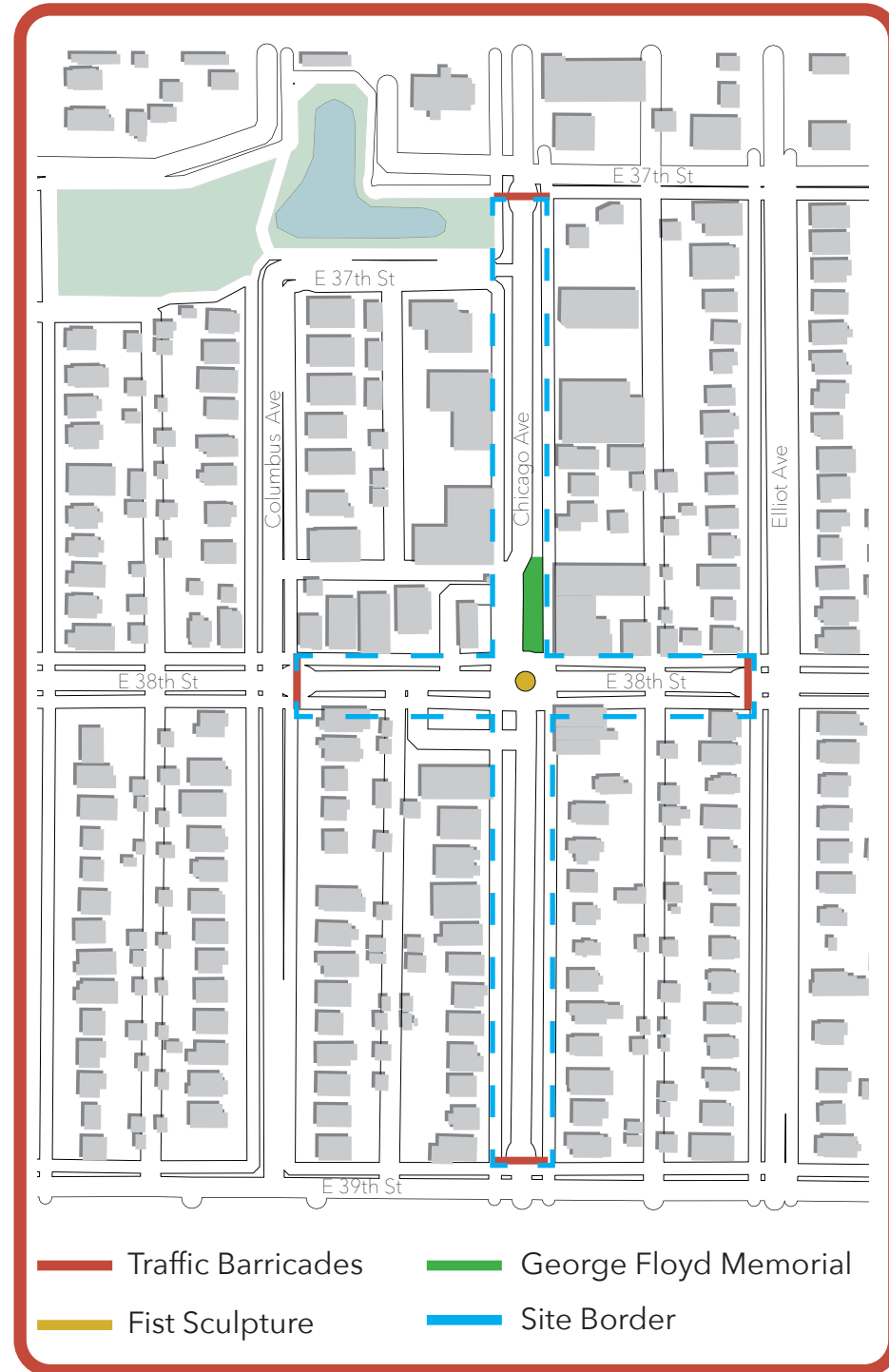

▲ FIST SCULPTURE

The replicated steel fist was designed by local artist Jordan Powell Karis and built with the assistance of other community artists from the nearby Chicago Avenue Fire Arts Center which is located on the site.

24 DEMANDS ▶

Members of the community organization "Meet on the Streets" asked that the city meet a list of 24 demands before dismantling the cement barricades and relinquishing the George Floyd Square.



**INFLUENCE
THE
DESIGN**

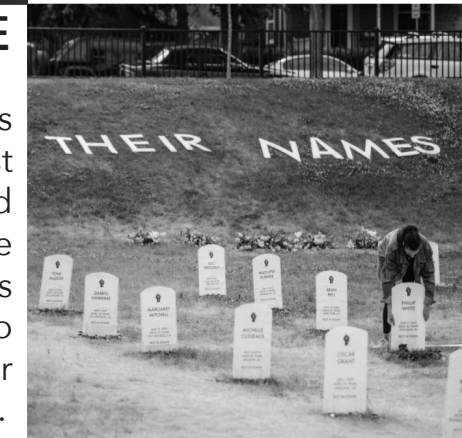

▼ PEOPLES WAY

The Speedway gas station, was damaged during the riots that followed Floyd's death. After the property was abandoned by its owner, activists painted it over with street art and re-branded it "People's Way".

◀ SAY THEIR NAME

In a grassy area at E 37th St and Park Avenue S, a block north from the center of the square, artists created a symbolic cemetery with 150 headstone markers for People of Color that had been killed by police.



◀ MURALS

the iconic blue and yellow mural of George Floyd on the side of the Cup Foods grocery store became one of the most recognizable images of the global protest movement that was sparked by his murder.

**PRESERV
THE
STREET
ART**



LAST BREATH ▶

Visitors from all over the world have come to pay their respects, many leaving offerings of creative expressions, flowers, stuffed animals, and photographs at the site of George Floyd's last breath.





YOU ARE NOW ENTERING THE FREE STATE OF GEORGE FLOYD



WE STILL DEMAND

GEORGE FLOYD SQUARE SITE ANALYSIS

Site

George Floyd Square is located on a two-block mixed use street in a mainly residential area at the intersection of East 38th Street & Chicago Avenue. Ideal in location because of its proximity to downtown, current historic events that happened on the site, and the connotations to existing fabric, locale, tradition, and vernacular. For my design It was important to preserve as much of the existing site as possible by forming a connection between events and a traditional mid-western architectural style of the surrounding structures.

Seasons

Minnesota features cold, snowy winters; hot, humid summers, and moderate fall and spring temperatures. The difference in average temperatures between the coldest winter months, and the warmest summer months, is around 60.1 °F, which is common in continental mid-western climates. Throughout the four seasons, Minneapolis sees a wide range of precipitation and related weather phenomena, including snow, sleet, ice, rain, thunderstorms, and fog.

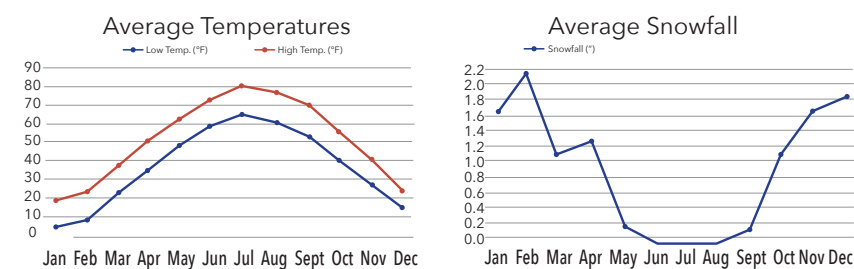

Accessibility

The site's circulation does not prioritize pedestrians or public transportation demands or needs in the Powderhorn Park community. With the streets reopened July 20, 2021, pedestrians are even more neglected, as many sidewalks now serve as makeshift memorials and vehicular traffic has resumed. Parking stretches into neighboring blocks, as there are no on site lots or structures; and Public transportation has been pushed more than 2 blocks away in order to avoid the intersection, despite the fact that more than 60% of residents rely on buses.

Tourism

Visitors from all over the world have come to George Floyd Square to see the ever-expanding living memorial. Coming in Not on to pay tribute to George Floyd, but for the countless other Black men and women who have been murdered. At one of the displays, push pins on a map depict all of the different areas people have visited from. They're all across the country, but there are also push pins marking tourists from Italy, Greece, Afghanistan, Pakistan, and a several other countries.

"We saw things remotely. We wanted to be here in person and see what this meant, and I'm impressed." "There's an aura here that is missed when you're far away."
- Dennis & Nancy Wagner ; New Hampshire.

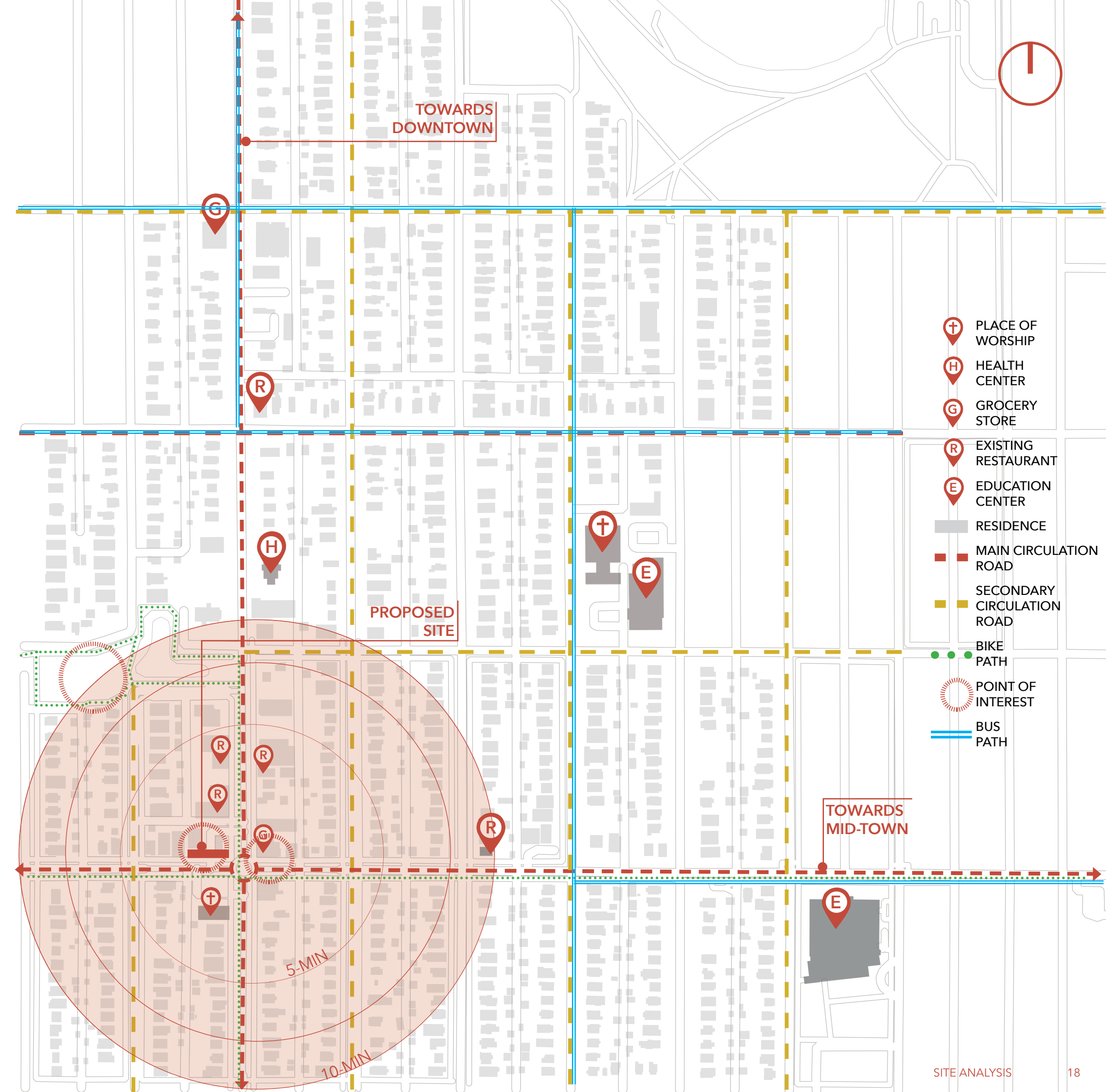



CIVIC ENGAGEMENT

[NOUN]

1. Working to make a difference in the civic life of one's community and developing the combination of knowledge, skills, values and motivation to make that difference.

RESPONSE TO A SOCIAL + CULTURAL CRISIS

Through the concepts of exchange and resistance by simply occupying the space, George Floyd Square is primarily built on people, space, and connectivity. Social interactions help to implement necessary changes in the local syndicate while cultural interactions respond to and involve the global audience in equality efforts through the use of social media. With urgent action required and lacking government support in regards to race and equality, the Powderhorn Park community has taken control on a neighborhood level to protect the safety and vitality of George Floyd Square.

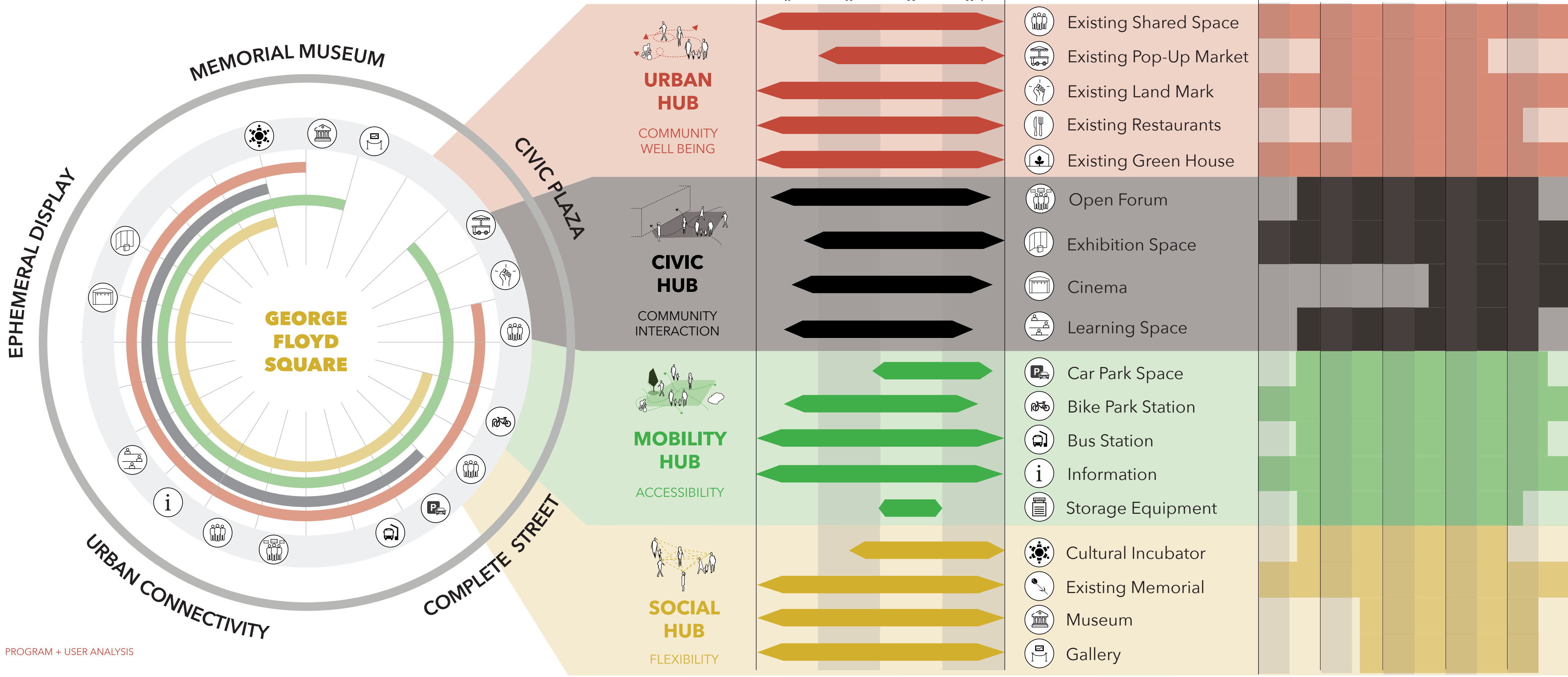

PHASE ONE DESIGN PROCESS

I wanted to highlight the existing properties by conserving all cultural artifacts currently in the area, while also continuing the argument of resistance and occupying the street by designing a building that respected all surrounding structures and only took up part of the street-scape. Though referred to as a square, the intersection is a makeshift plaza that did not safely separate pedestrians and vehicular traffic or allow for other forms of spontaneous large events. To combat this, I needed to understand what was being preserved in this space as well as what other factors - political, social, civil, or otherwise - would impact my design choices. I anticipated this to be a difficult challenge to design for, especially when I realized most memorials honor one event, time period, or location. I was creating a memorial to commemorate events that do not only deal with the events of George Floyd, but needed to honor events that continue to this day all over the untied states. I knew I had to respect the lives of unarmed people of color while also making the space and architecture malleable in response to social change, new victims, and other modifications to the area as requirements changed and time passed.

DESIGN CHALLENGES

- 1 What are the problems to be addressed?
- 2 What Do you preserve in a living memorial?
- 3 Where should the design focus?
- 4 Why is it important to continue to preserve this space?
- 5 When is the memorial complete?

CURRENT ORIENTATION

The current orientation of the "square" does not coincide with the needs of the space especially in terms of tourism, community use, safety, engagement, the local market and idea exchange.

"This space is a space that has now become a national memorial, a national memorial for victims of police violence all over this world,"
 - South Minneapolis Community resident

IDENTIFYING ISSUES

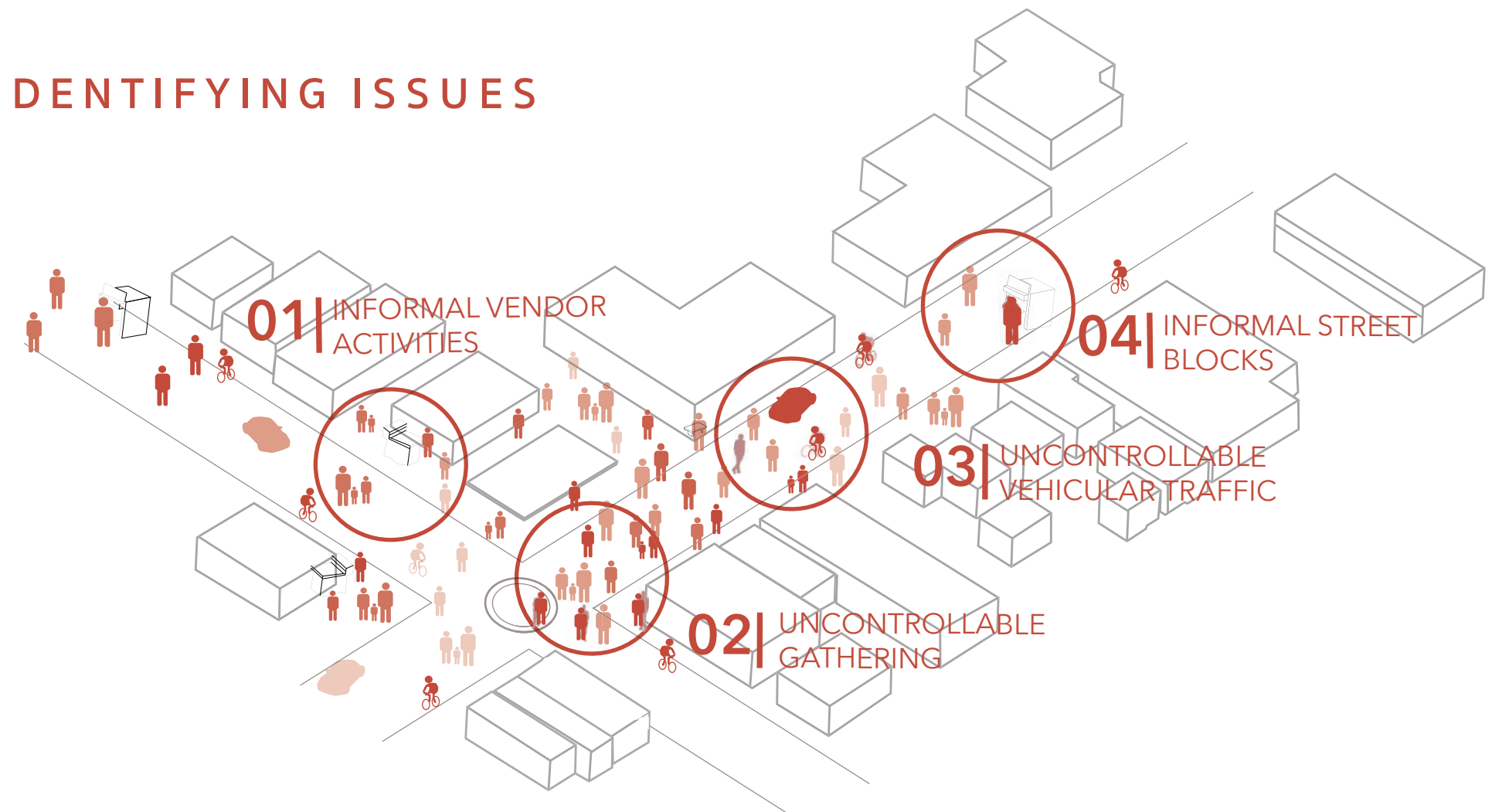

DESIGN STRATEGIES

01 RE-ORGANIZE VENDOR SERVICES

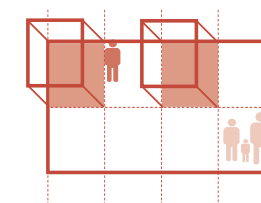

02 REGULATE ACCESS AND GATHERING

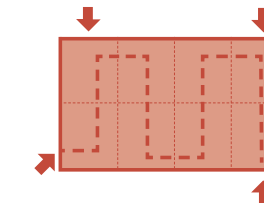

03 RE-ORGANIZE VEHICULAR TRAFFIC

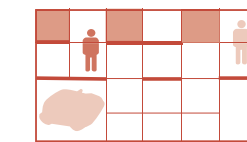

04 INTRODUCE REMOVABLE STREET BLOCKS

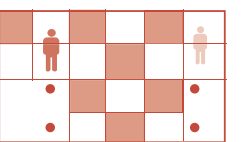

|1|

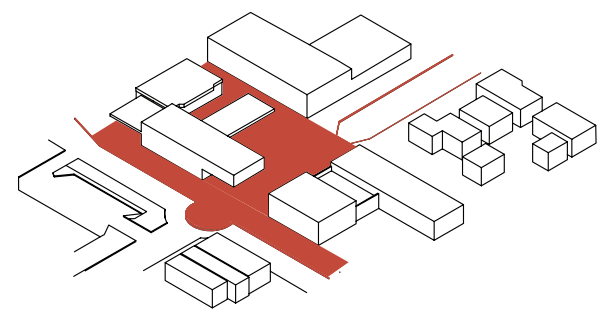

DEFINE SITE CONDITIONS

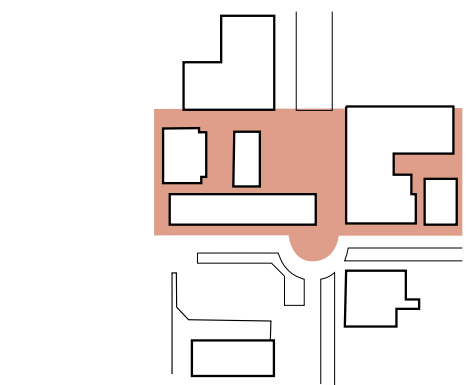

Partially restricting street access, the surrounding ground conditions were adjusted to establish distinctive pedestrian and vehicular access on Chicago Avenue.

|2|

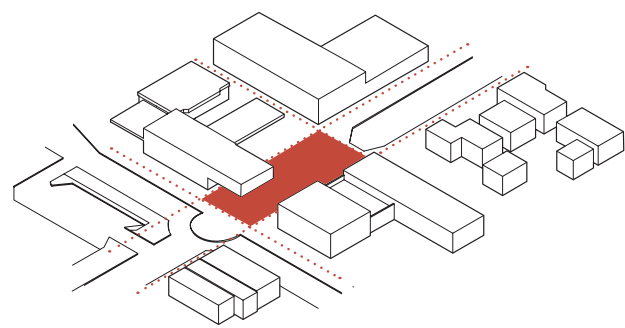

REORGANIZING CONTEXT

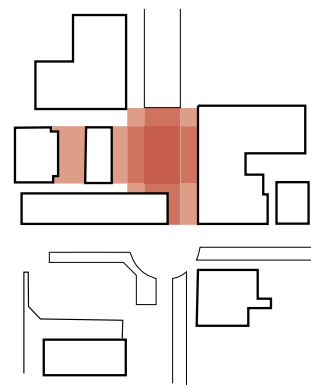

A pedestrian-friendly plaza is formed based on the surrounding built context, allowing for street activation and limitless flexibility on two separate axes.

|3|

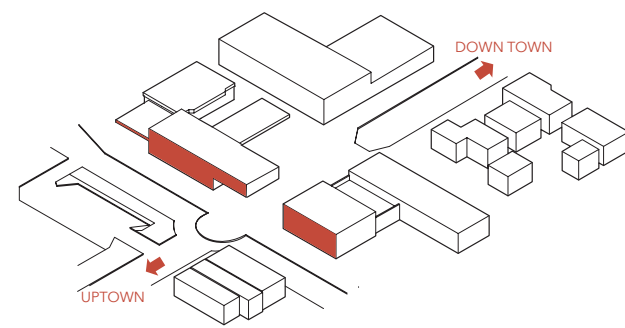

DEFINE EDGE CONTROL

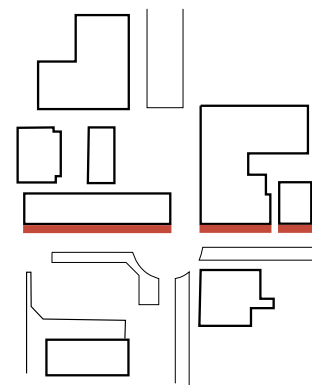

The addition of the museum helped to create a physical and visual edge that also serves as a cultural catalyst on the border between uptown and downtown.

|4|

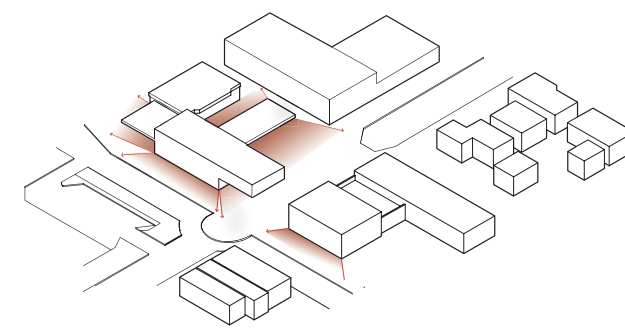

REDEFINING OUTDOOR SPACE

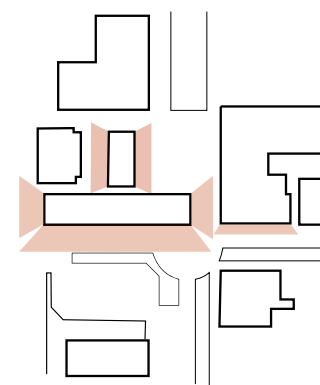

The relationship between the buildings and context of the plaza is restructured by altering the volumes to articulate room for outdoor activities and spaces.

|5|

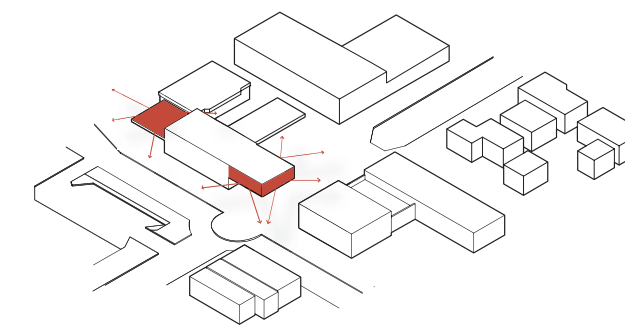

DEFINE ELEVATED VIEWS

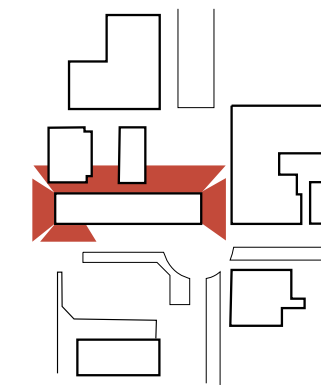

The majority of the southern side of the building is clad in metal siding while the northern side is open maximizing the views to the plaza and continued street below, this opened the site up for a safe opportunity for site exploration

|6|

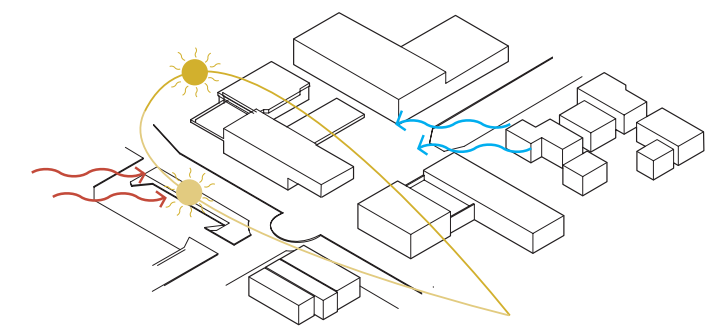

CONTROL THE ELEMENTS

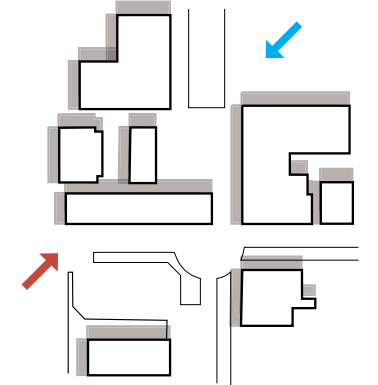

The orientation of the building allows control of the summer and winter winds and optimize the day lighting and shade during the different seasons.

SPACIAL INTERVENTION

Spatial Intervention

The architectural vision for the reconstruction of George Floyd Square aims to improve the unplanned civic center as both a ceremonial meeting place that promotes pride and a space for regular local use. I wanted to highlight the adjustments made to the plaza based on the community's assessment of the circulation, regular square events, and integration requirements and aspirations. There is cohesion across the living memorial with ceremonial spaces that commemorate the recent history with capacity for large demonstrations and celebrations. At the same time, it introduces intimate areas that serve as everyday attractions and provide a variety of experiences and facilities to local community members. This sense of teamwork unites the whole community and acts as a benchmark for future development.

Circulation

by retaining the perimeter circulation left over from the existing path ways, a connection between the primary buildings and the newly formed plaza is calcified. Taking cues from the most important and immediate site settings, a new flow of energy is generated between the site's urban and residential links. By making East 37th Avenue a one-way roadway, the plaza gains enhanced accessibility, safety, and movement management.

Programming

The plaza is the most active hub in the powderhorn park district and attracts people from all around the world. With a wide range of age groups and aspirations to visit the site, I believed it was critical to consider the incorporation of flexibility through varied active and passive activities in the civic space to guarantee that people could come together. There is an existing memorial where George Floyd took his final breath, as well as a plethora of gallery-worthy street and local art and an open form for idea and theory exchange already on the site. My objective was to improve these features by providing a permanent platform for these concerns and issues to be addressed and resolved.

Spatial Definition

By allowing the site to define the plaza's edges and bounds, a space inside a space was created. This enabled not just place identity, but also the movement of individuals between indoor and external surroundings in both the private and public spheres.

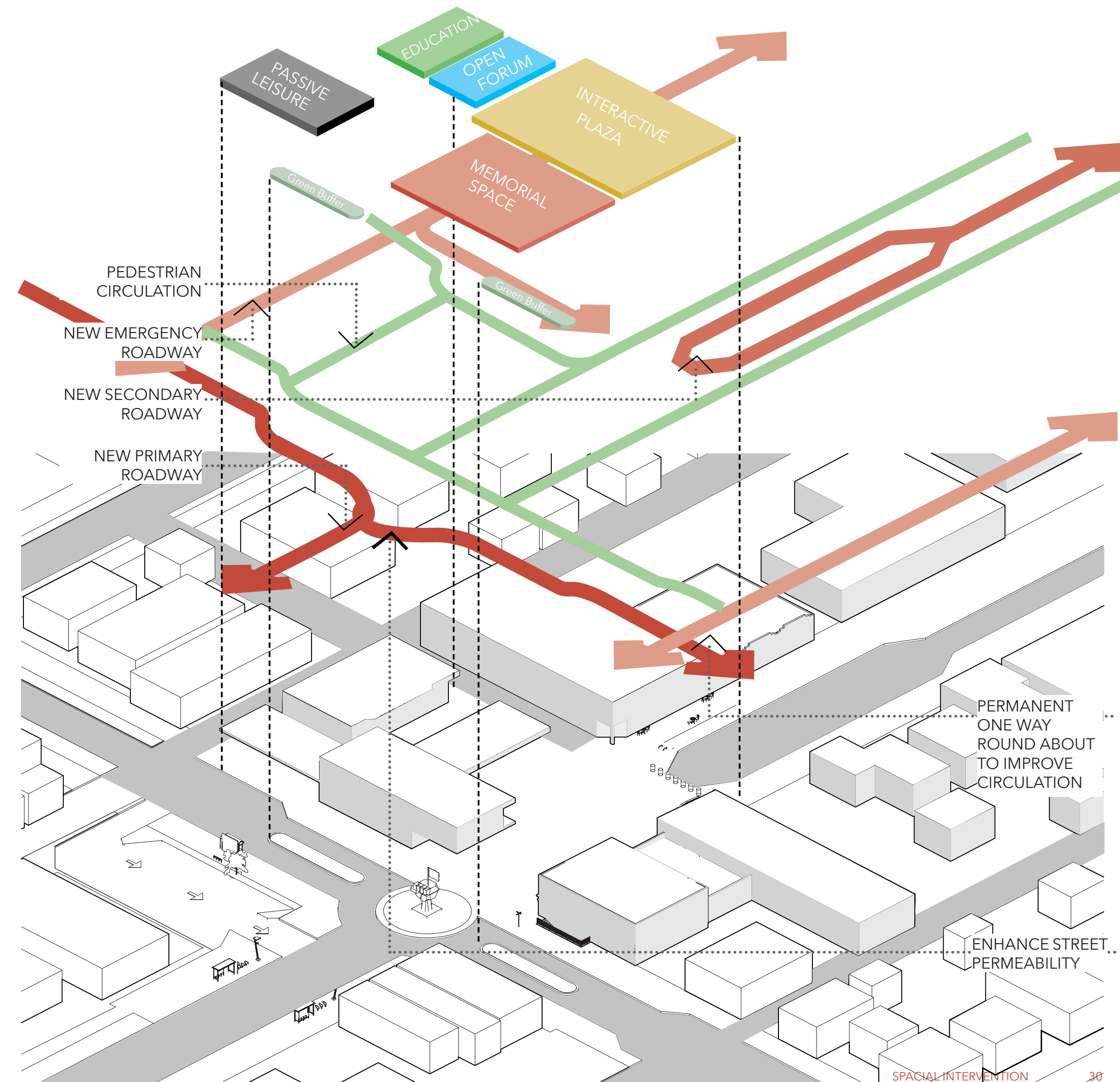

SITE PLAN

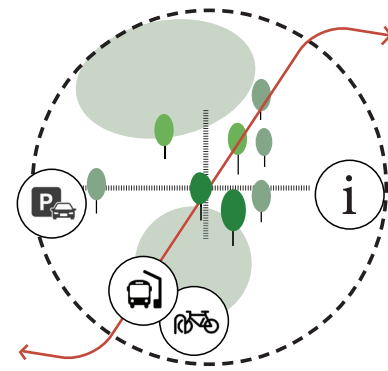

WALK-ABILITY

The newly proposed site plan encourages walk ability among the site through the use of the plaza. Surrounding amenities like existing restaurants, gallery, and neighborhood work force are still accessible and transportation needs are met for the users of the site.

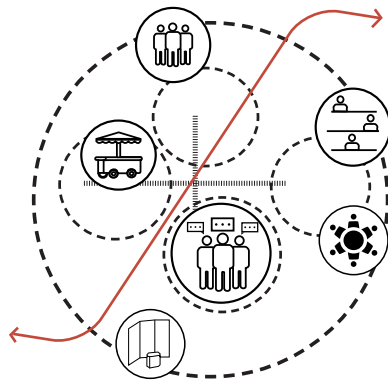

UTILITY & RECREATIONAL CORRIDORS

The integrated corridors enable public recreation, habitat conservation, and vehicle-free people movement all at the same time. The project's high exposure draws the public's attention, and by balancing the sometimes contradictory demands of all users, one may successfully combine the many services while remaining cost-effective.

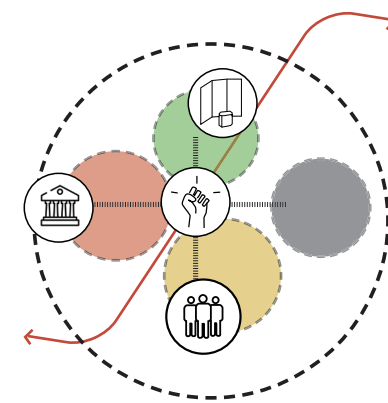

PERMEABILITY

The site allows the urban forms to permit and restrict the movement of people and vehicles in different directions of the site. Permeability is generally considered a positive attribute of the urban design principles I enacted, as it permits ease of movement and avoids severing neighborhoods.

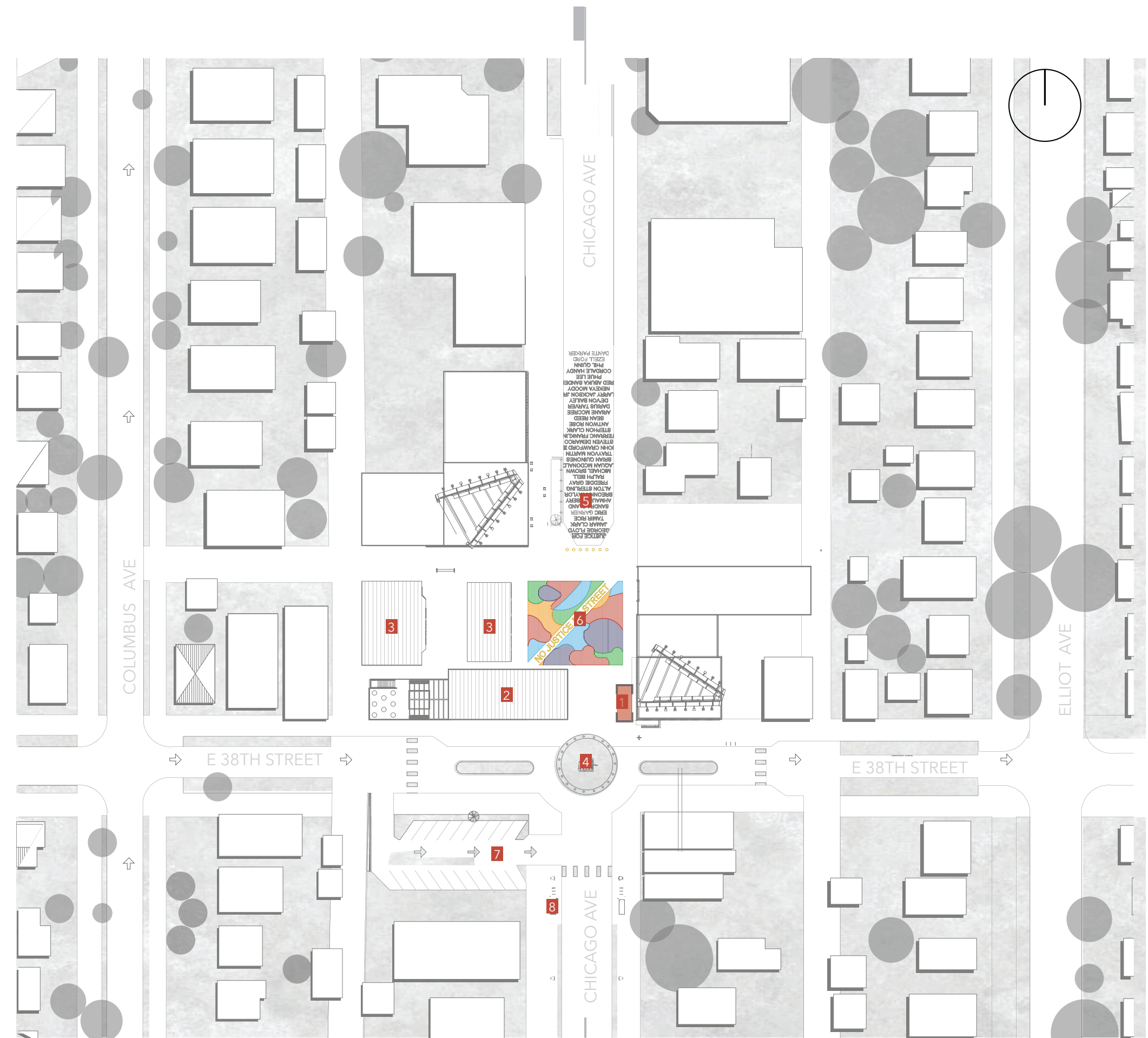

- 1. GEORGE FLOYD LAST BREATH MEMORIAL
- 2. REMEMBRANCE MUSEUM & CULTURAL CENTER
- 3. PEOPLES WAY GAS STATION
- 4. FIST SCULPTURE
- 5. SAY THEIR NAMES ROAD MEMORIAL
- 6. PLAZA
- 7. On- Site Parking
- 8. On-Site Bus Stop













MASTER PLAN WITH LANDSCAPE DETAILS
SCALE - 1:8





SITE SECTION

Through the use of design, engagement, representation, history, community input and theories, The Reimagined George Floyd Square may begin to establish a supportive and optimistic environment for the community to move forward in a constructive manner. By enabling community influences to steer the project and involvement goals such as support for racial reconciliation, education, and community development, the square can grown into the land mark monument it as proven to be. Preserving this public space and constructing it in a way that encourages people to assemble freely, to hold community events, to provide forums for dialogue and healing, and to memorialize the irreplaceable legacy and lives lost in a safe and meaningful manner. The changes to the site i have proposed will allow all of my goals to be accomplished and still have room for growth as community needs change in the future, support the heavier visitor traffic that continue to flock to the site.

-  Shared Space
-  Pop-Up Market
-  Land Mark
-  Open Forum
-  Exhibition Space
-  Learning Space
-  Bike Park Station
-  Information
-  Cultural Incubator
-  Memorial
-  Museum
-  Gallery
-  Existing Green Space

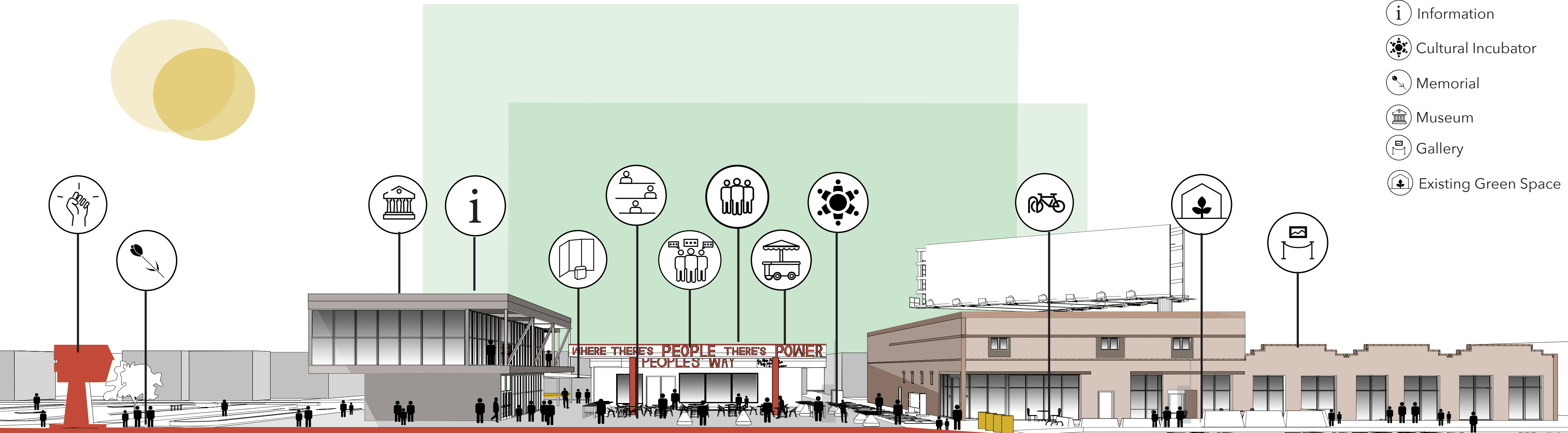

PLAZA ACTIVATION

The most significant stage in transforming the site was converting George Floyd Square into an active and comprehensive plaza for long-term usage. Referencing both the Minneapolis 2030 Plan and existing programmatic concerns, it was determined that social, spacial and economic perspectives were essential elements that needed to be incorporated throughout the design.

The activation strategy included developing a flexible plaza for year-round activities targeted at engaging and growing the community, generating interest in education about the systemic issues that the square was intended to arouse, and recruiting place-making ideas. The activations serve the local community and beyond by bringing together local artists, vendors, and fabricators, the majority of whom reside just next door. A variety of temporary and interactive installations are available, including a mapping of visitors traveling to the location and a site-specific mural by a local artist. By overlaying the plaza with an enhanced and participatory art experience, as well as providing community-based programming that includes local, national, and international individuals impacted. The experience ultimately provides a new reference point in future media that documents George Floyd's story and the potential for the square orientation to encompass a cultural canvas that lends itself to dynamic, diverse, and inclusive programming. A key component of the plan was curating the unknown or having the room to anticipate the unknown while in the space.



IN TIMES OF MARKET

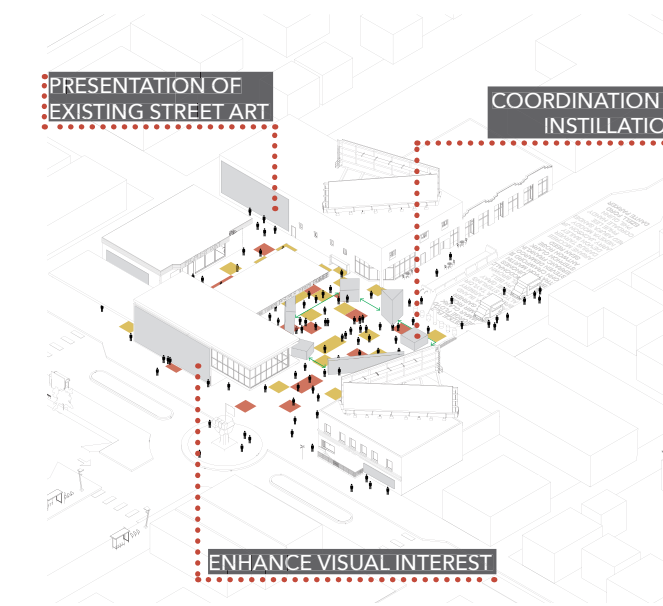

IN TIMES OF EXHIBITION

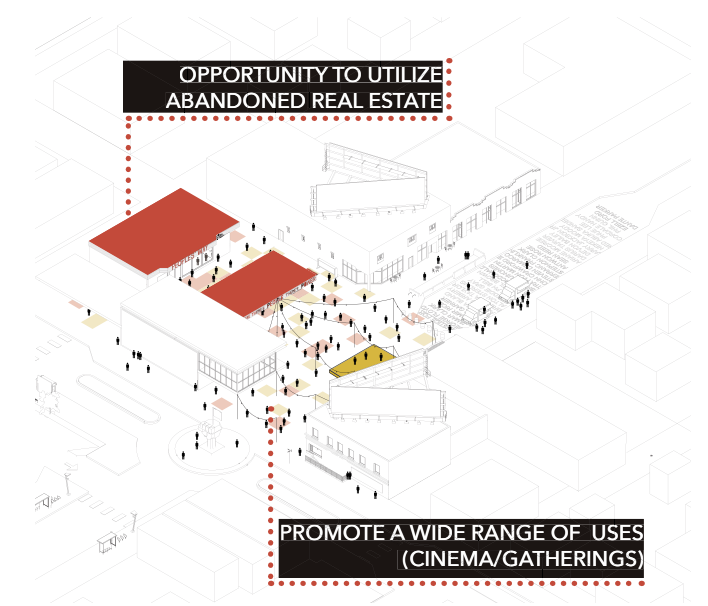

IN TIMES OF COMMUNITY EVENTS

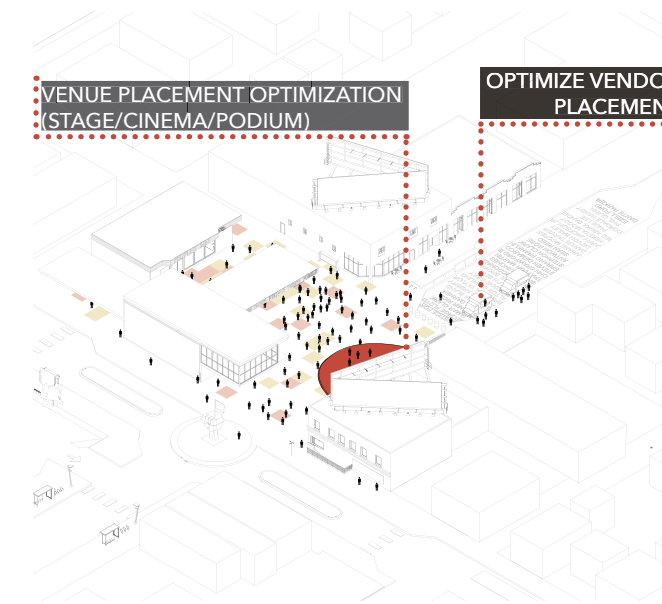

IN TIMES OF PERFORMANCES

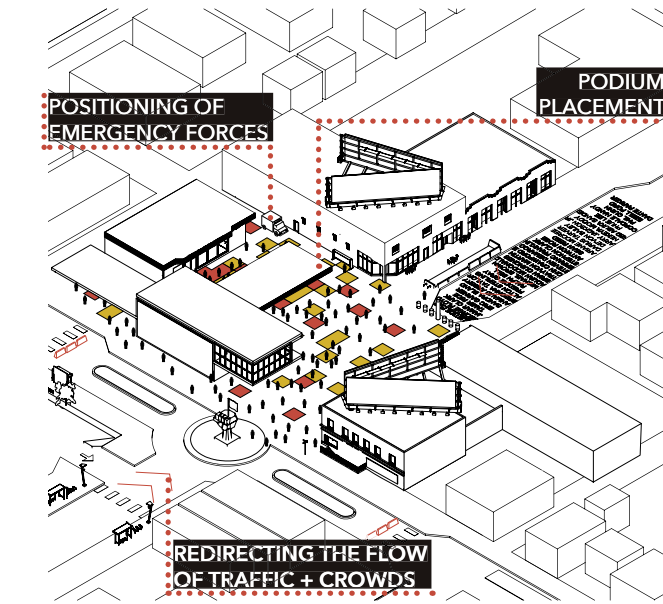

IN TIMES OF PROTEST

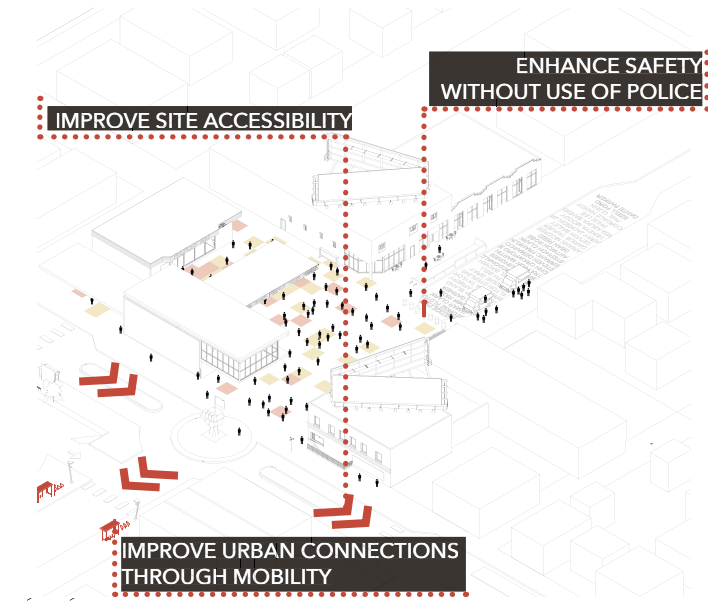

IN TIMES OF MOBILITY

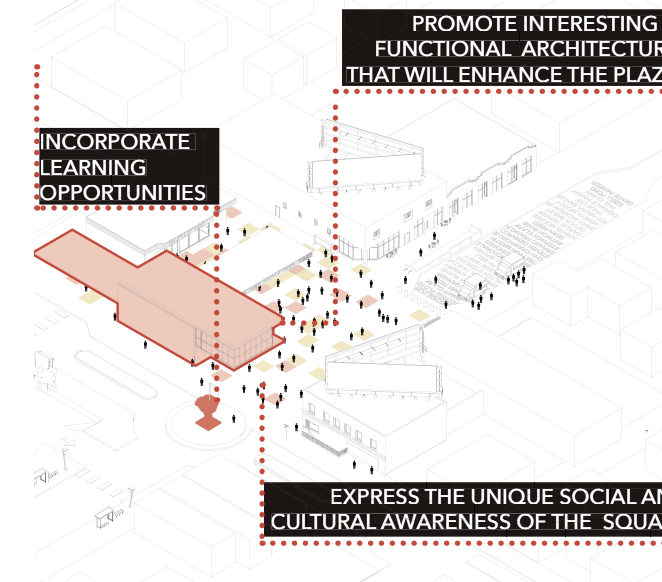

IN TIMES OF EDUCATION

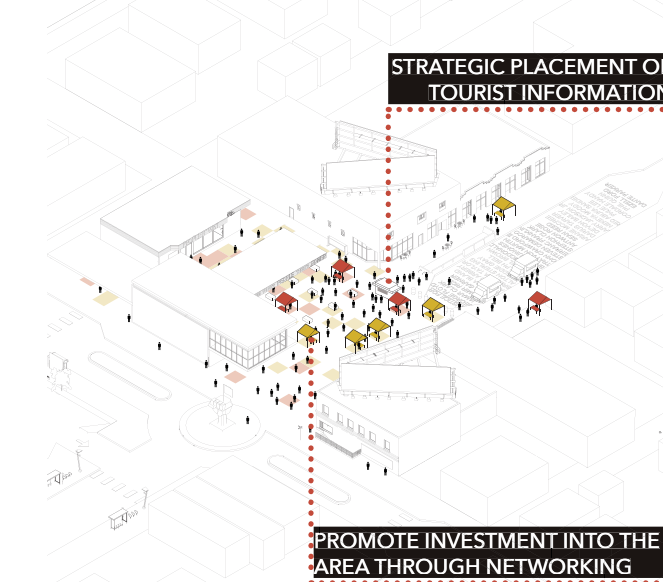

IN TIMES OF COMMUNITY GROWTH

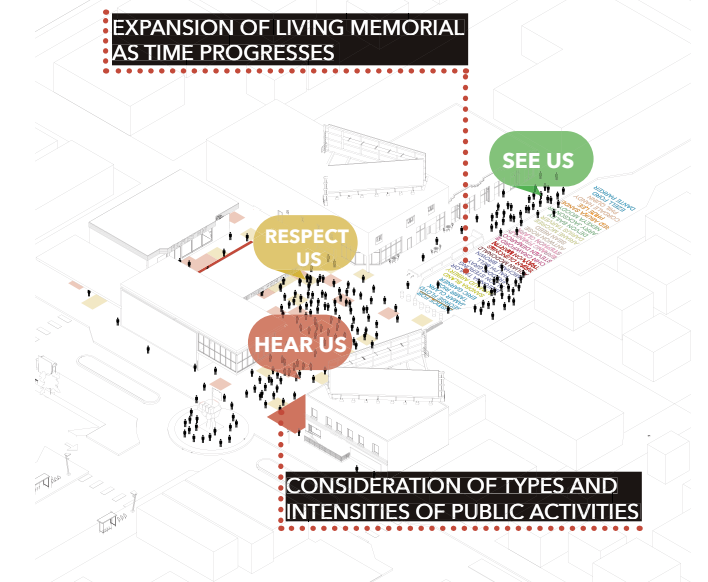

IN TIMES OF MEMORIAL





RESISTANCE

[NOUN]

1. An act or instance of resisting
a: OPPOSITION
2. an underground organization engaging in operations against occupation forces and collaborators:
a: Revolt
b: Uprising

|1|

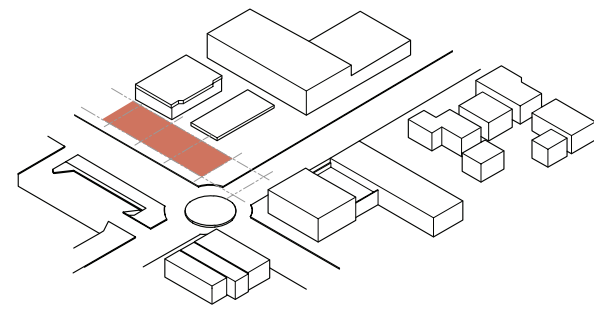

SITE CONDITIONS

|2|

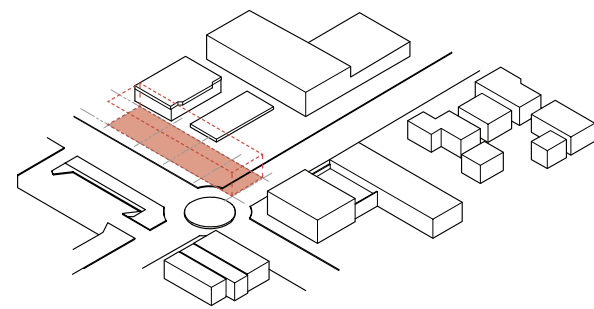

FORM PRODUCTION

|3|

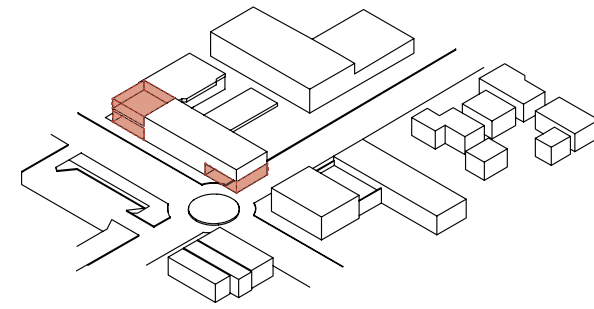

DEFINE VOIDS & ACCESS

|4|

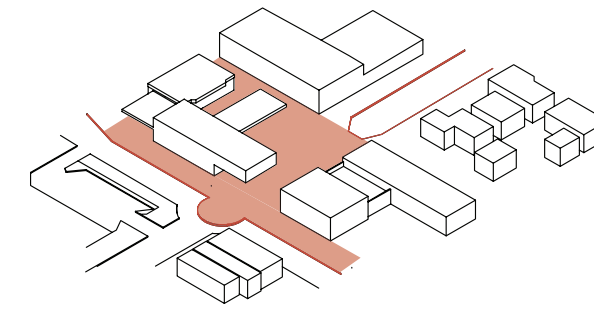

DEFINE SITE CONDITIONS

|5|

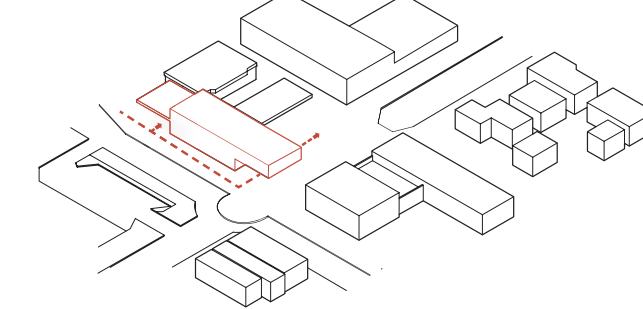

OPTIMIZING SHAPING

|6|

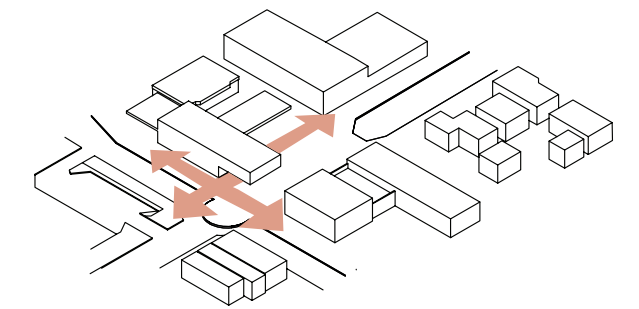

URBAN CONNECTION

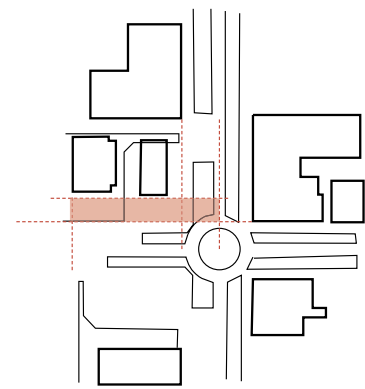

Using the other building on the site to provide the grid lines of the new building

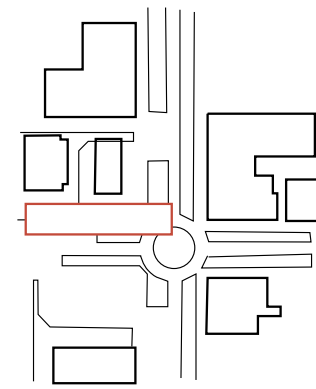

The form of the building is aliened to the heights of its surrounding buildings to ensure balance of old and new.

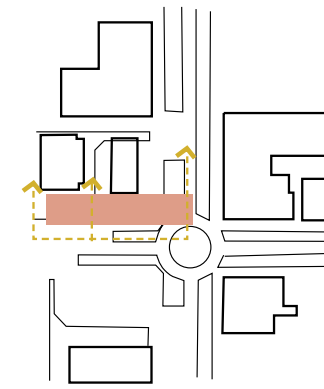

The voids of the building are defined by the access points to gain entry into the plaza.

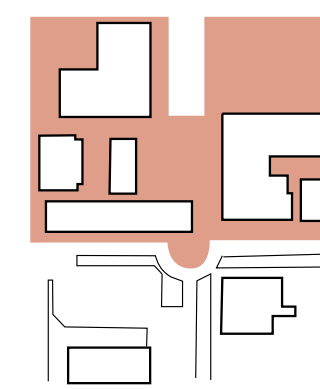

The orientation of the site and ground conditions were modified to create a pedestrian friendly plaza.

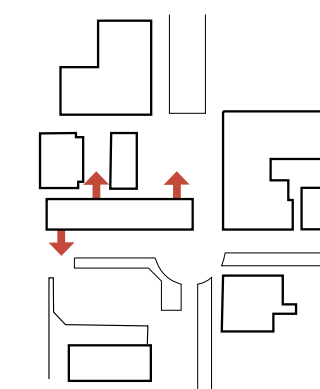

Mimicking the surrounding roof lines and creating multiple access points allows the plaza space to feel balanced and extend down E Chicago Ave.

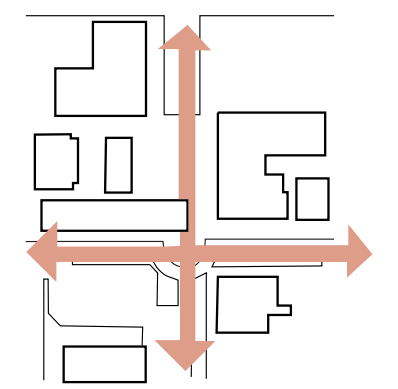

The building helps to build an urban connection to the rest of the surrounding neighborhoods and commercial setting.

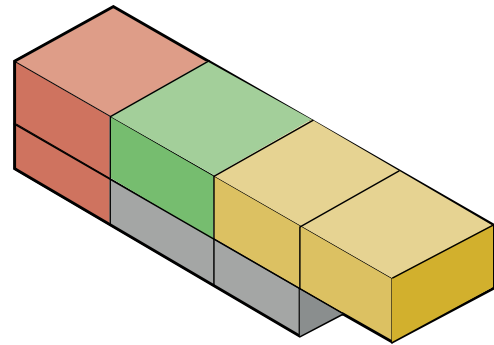
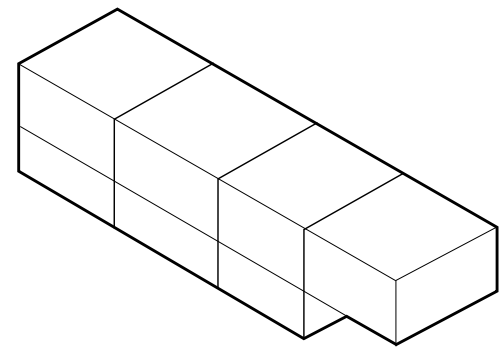

TOTAL PROGRAM

PROGRAM SIZES

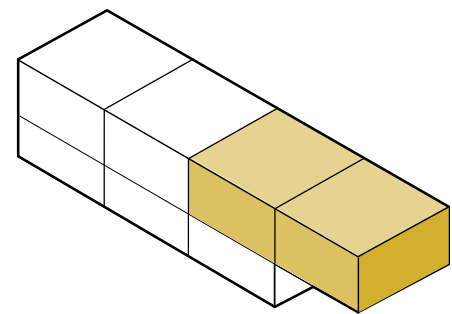

EXHIBITION FORUM

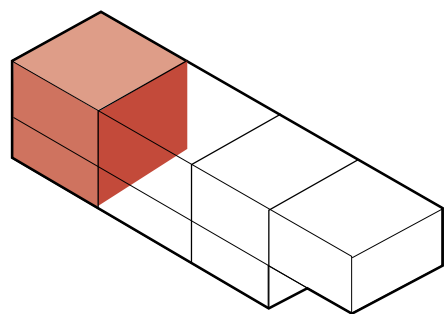

OUTDOOR FORUM

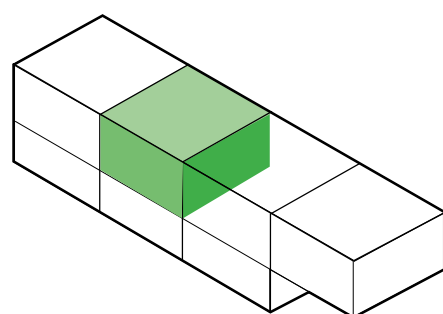

ART GALLERY

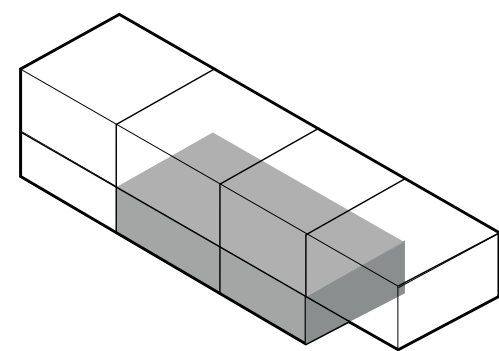

ENTRY / LOBBY / ADMISSIONS / STORE

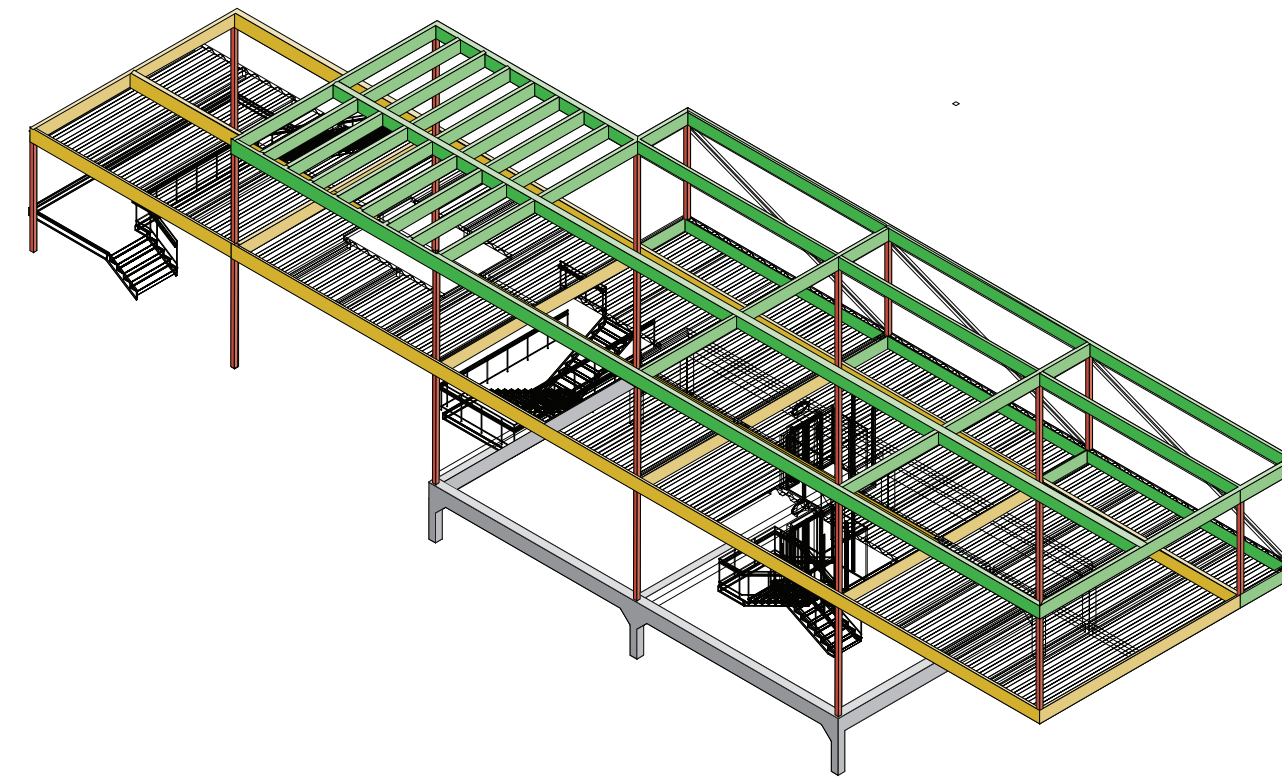

STRUCTURAL SYSTEM

The structure is constructed using steel and concrete hybrid rigid framing system designed to allow flexibility over time, vast open spaces, and utilization of prefabricated building processes.

The modular planning of the 30' x 30' grid is utilized as the concrete primary footing loads and supports the steel framing above. Internal cores, concrete slabs, and diaphragms are used as stabilizing components to withstand wind stresses and loads.

LIFE SAFETY SYSTEM

The structure includes enclosed fire stairs, fire alarms, gas detection systems, emergency exits, and first and second floor exterior egress for safe evacuation for all occupants during any hazard circumstances. During a fire hazard all load bearing walls have fire resistance ratings up to 2 hours with response to code, as well as

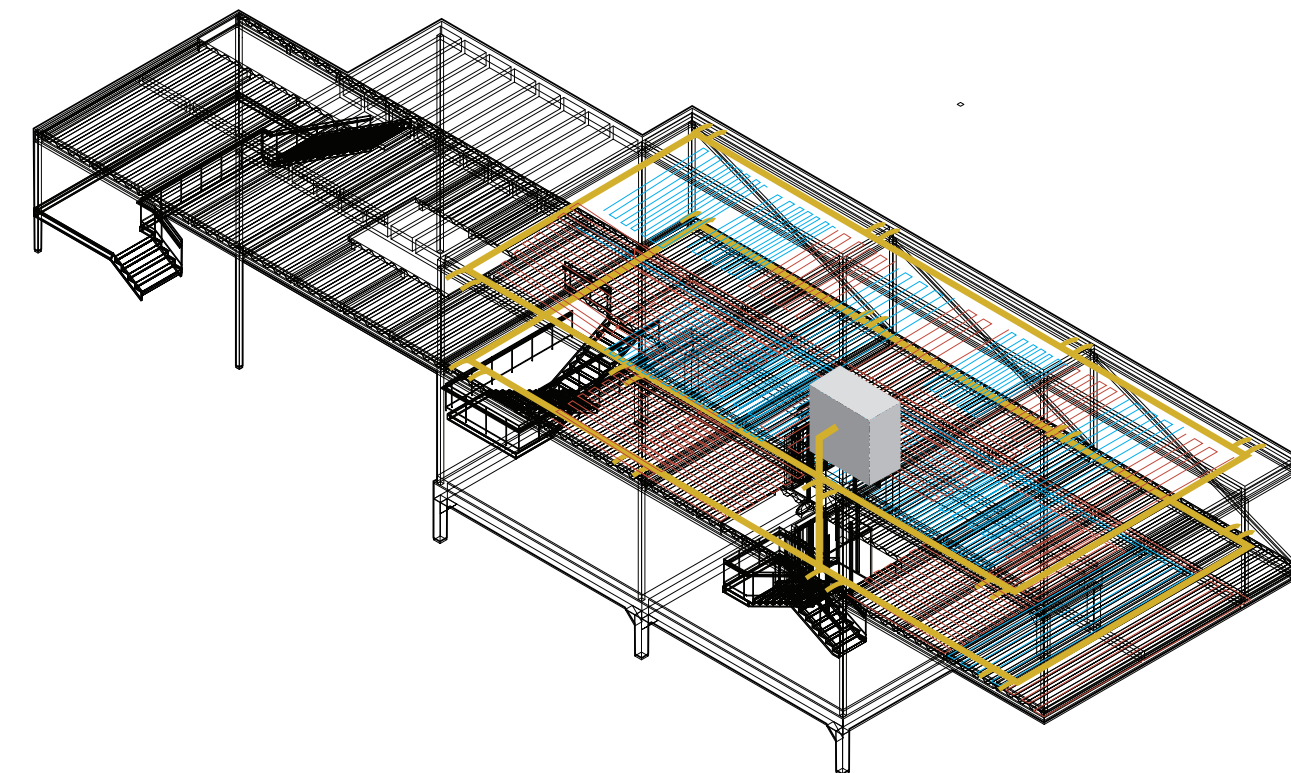
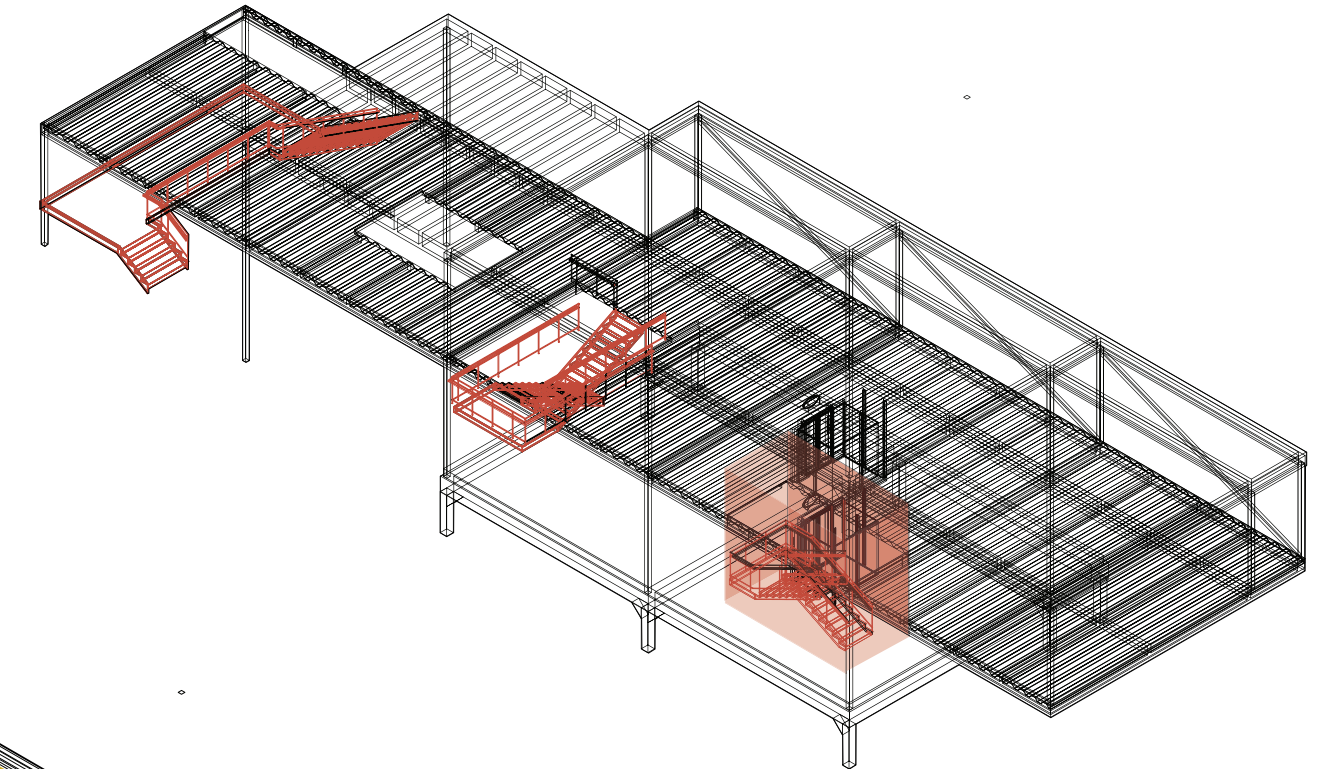

MECHANICAL SYSTEM

The structure is composed of a variable air volume system (VAV) which provides close control over all interior temperature and RH levels for low maintenance, noise reduction, flexibility, constant temperature and variable airflow. The structural material and placement allows for all internal walls and ceilings to be constructed with duct work space. Additionally, the building has been designed for humidity control, air barrier, vapor retarder, and thermal insulation systems that are sufficient and continuous as recommended for museums.

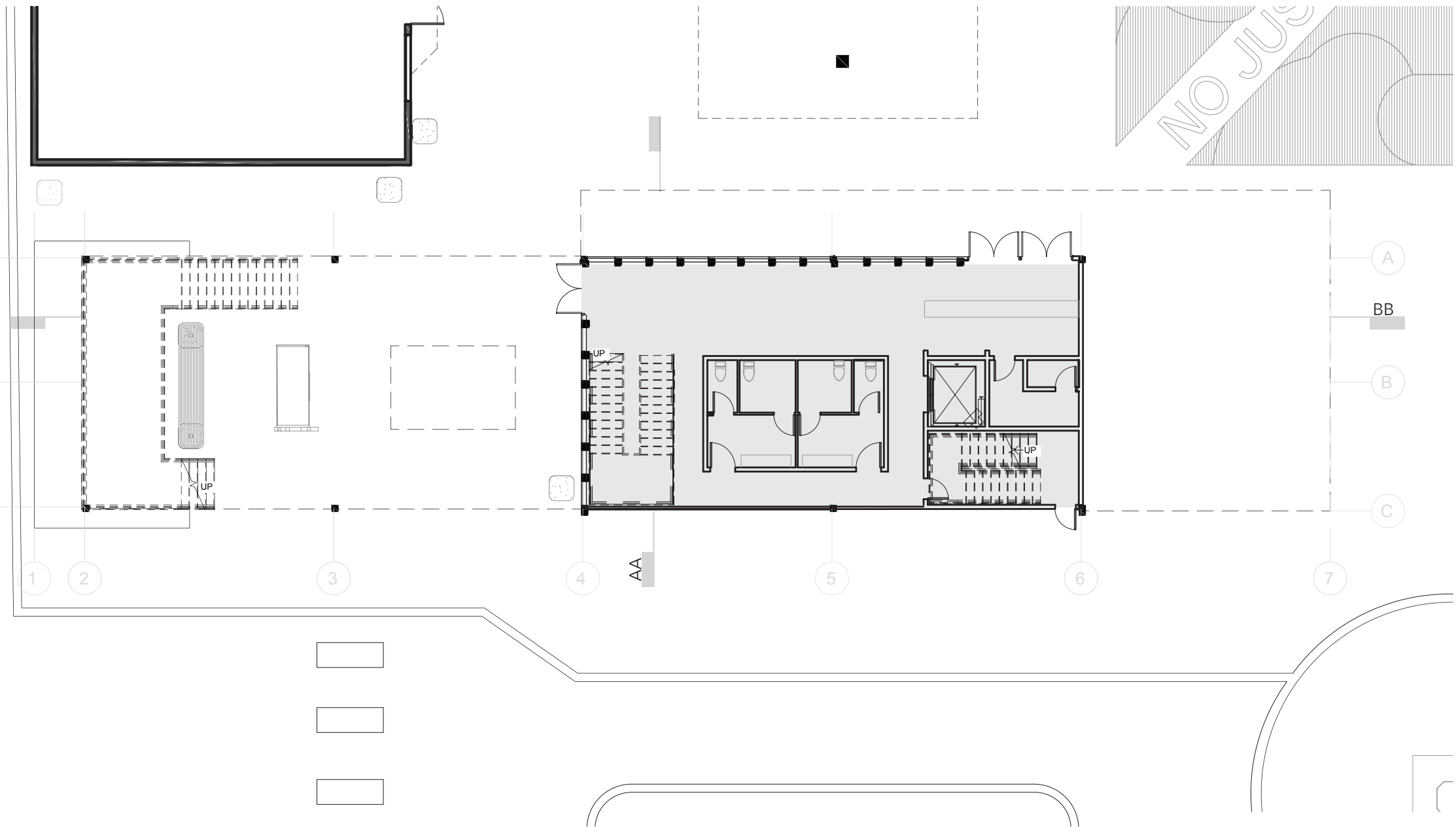

GROUND FLOOR - PLAN
1'-0" = 0'- 1/8"

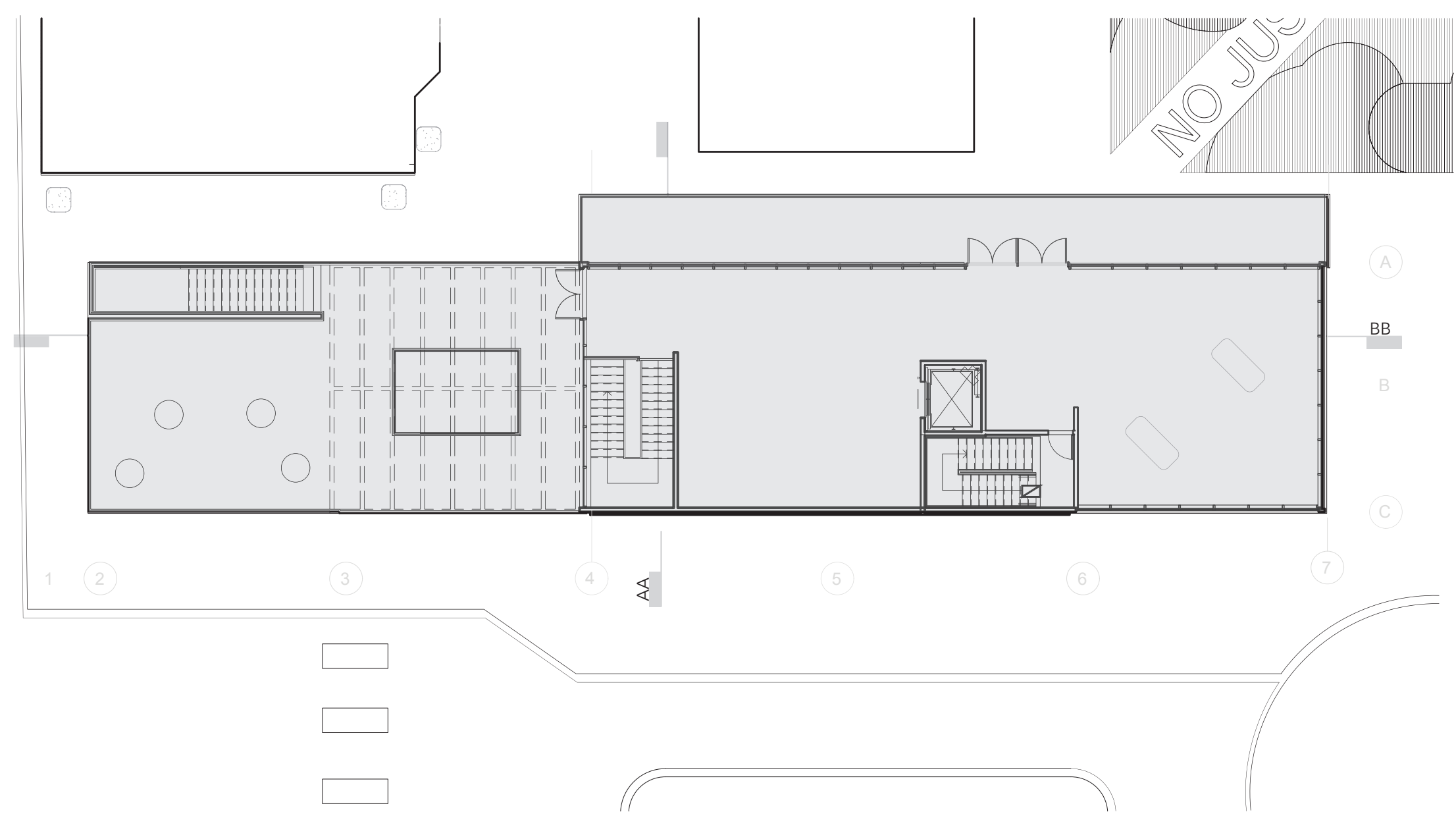

SECOND FLOOR - PLAN
1'-0" = 0'- 1/8"

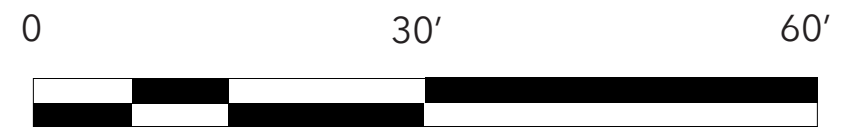

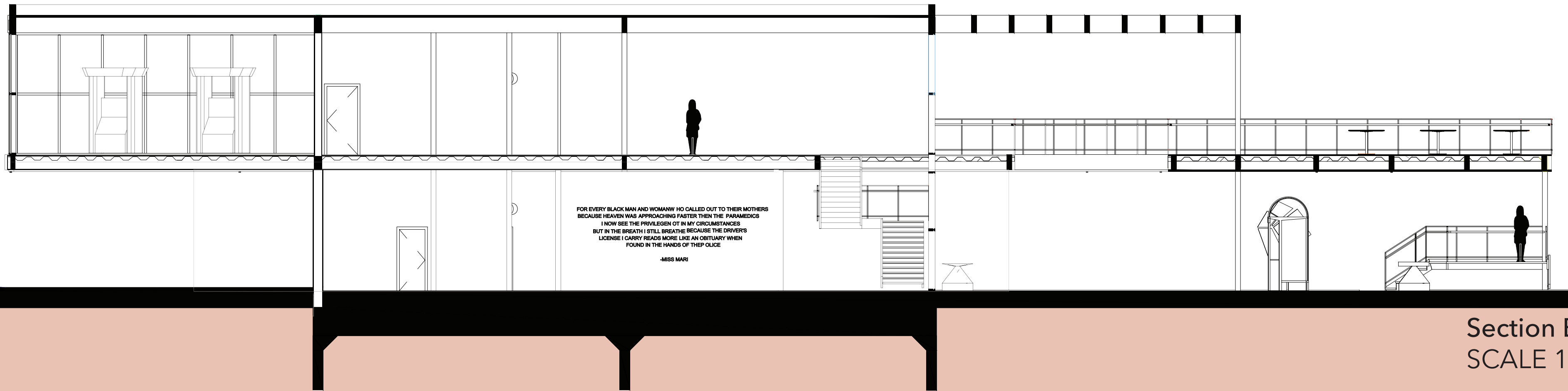
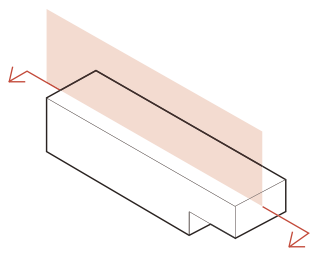

Section BB
SCALE 1/8"

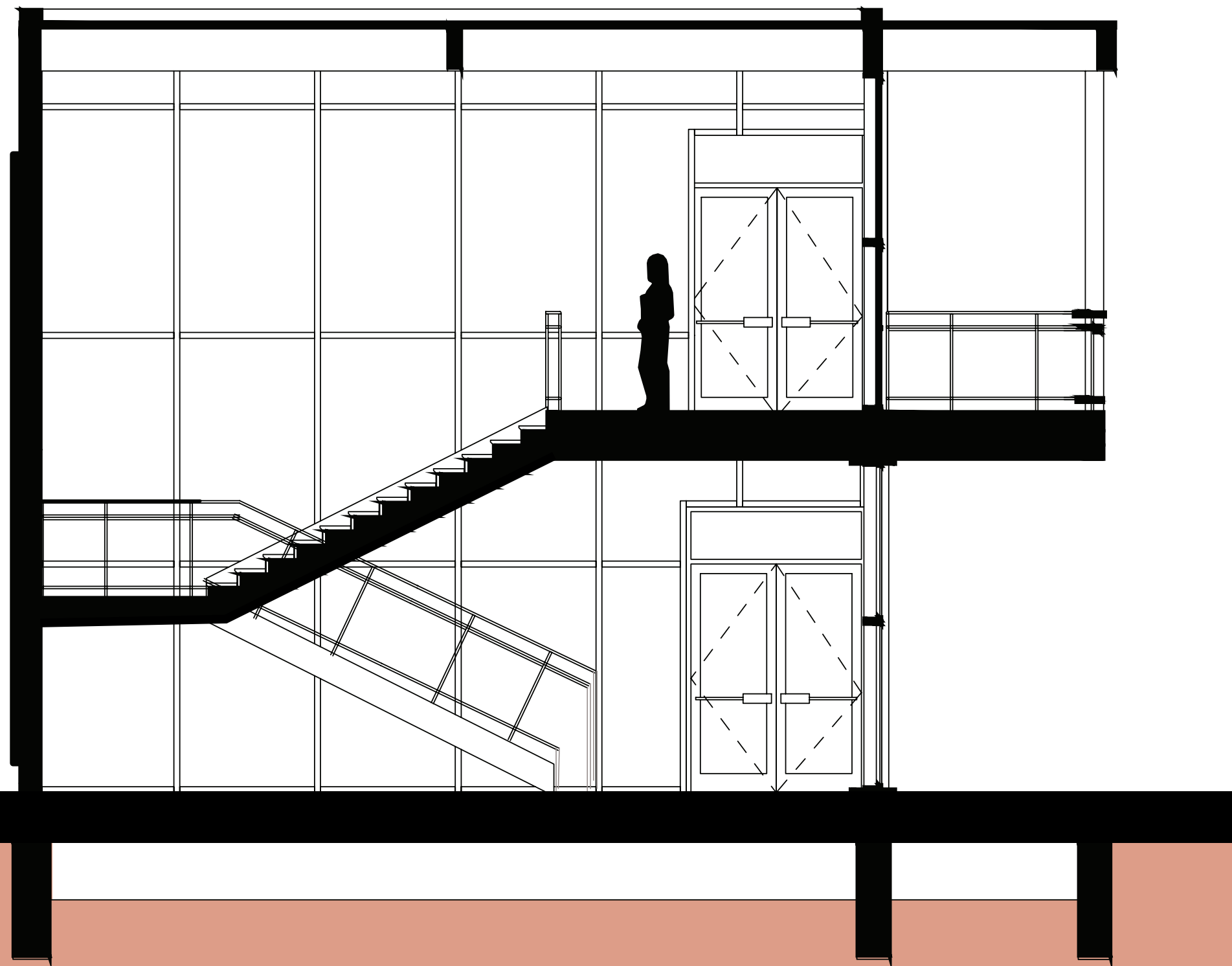
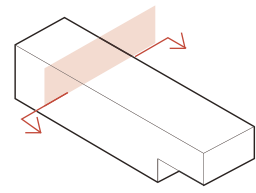

Section AA
SCALE 1/8"

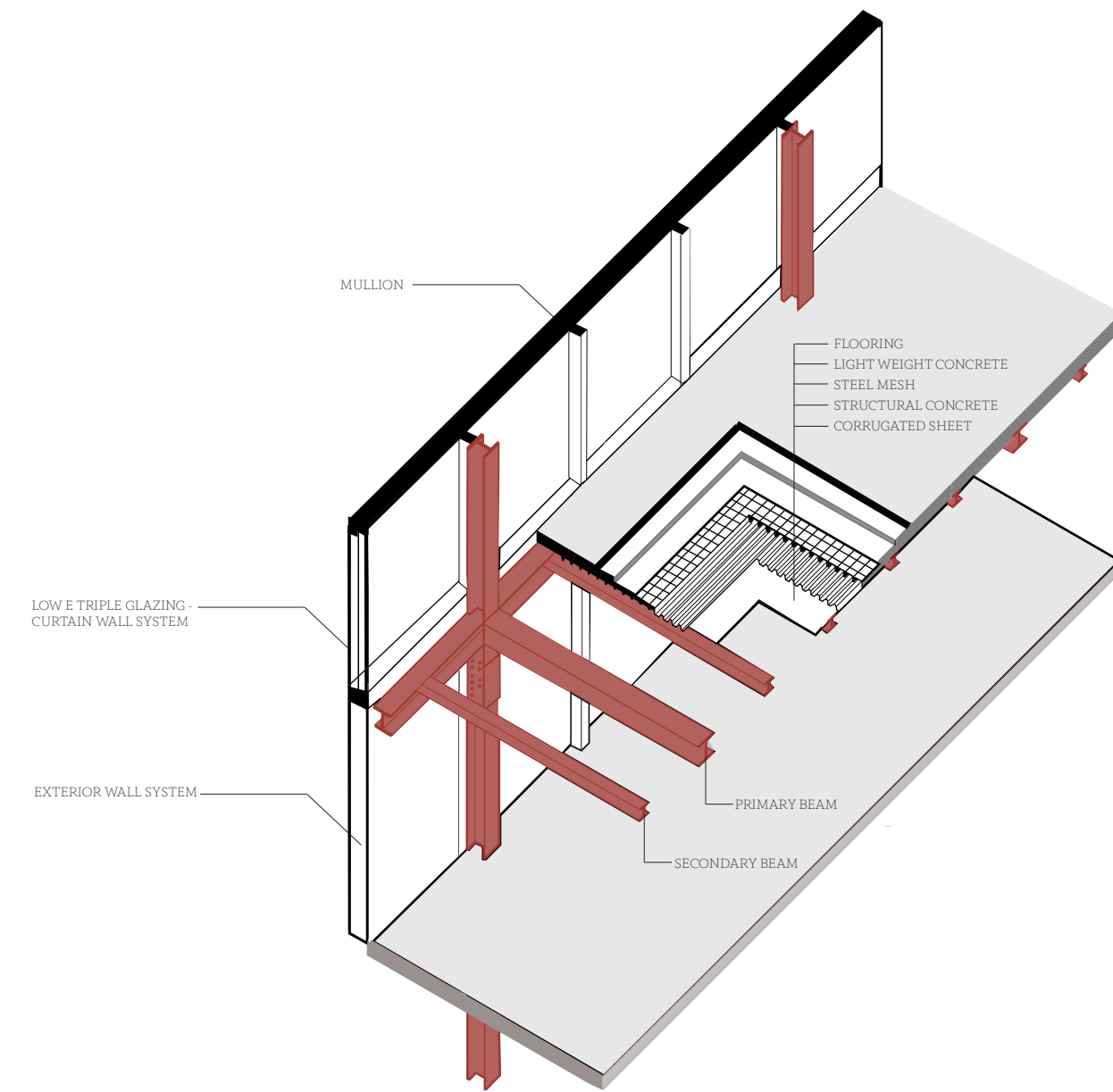

ROOF DETAILED SECTION

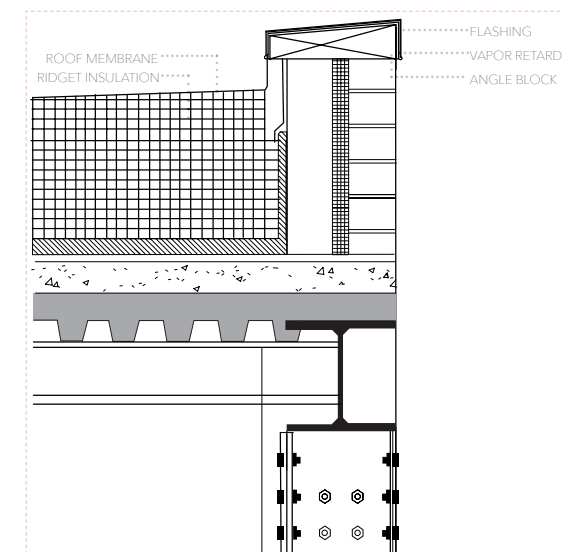

1/8" = 1' - 0"

CONNECTION DETAILED SECTION

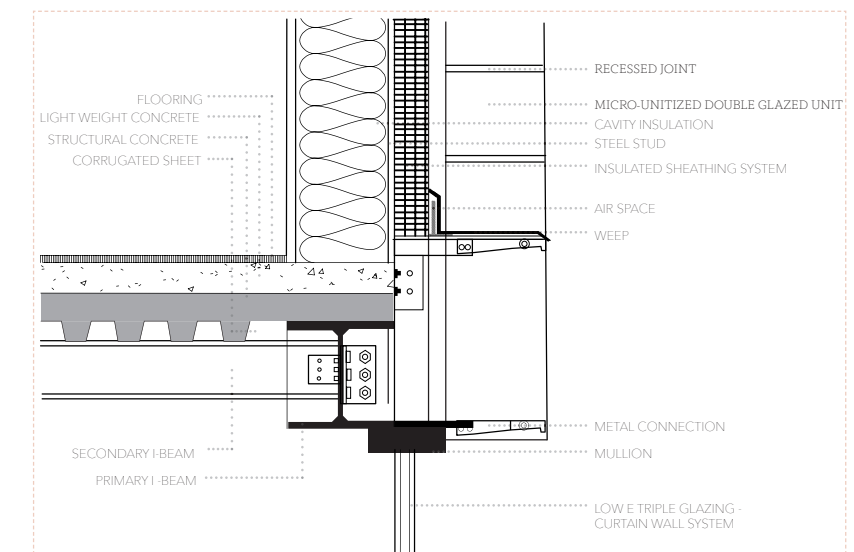

1/8" = 1' - 0"

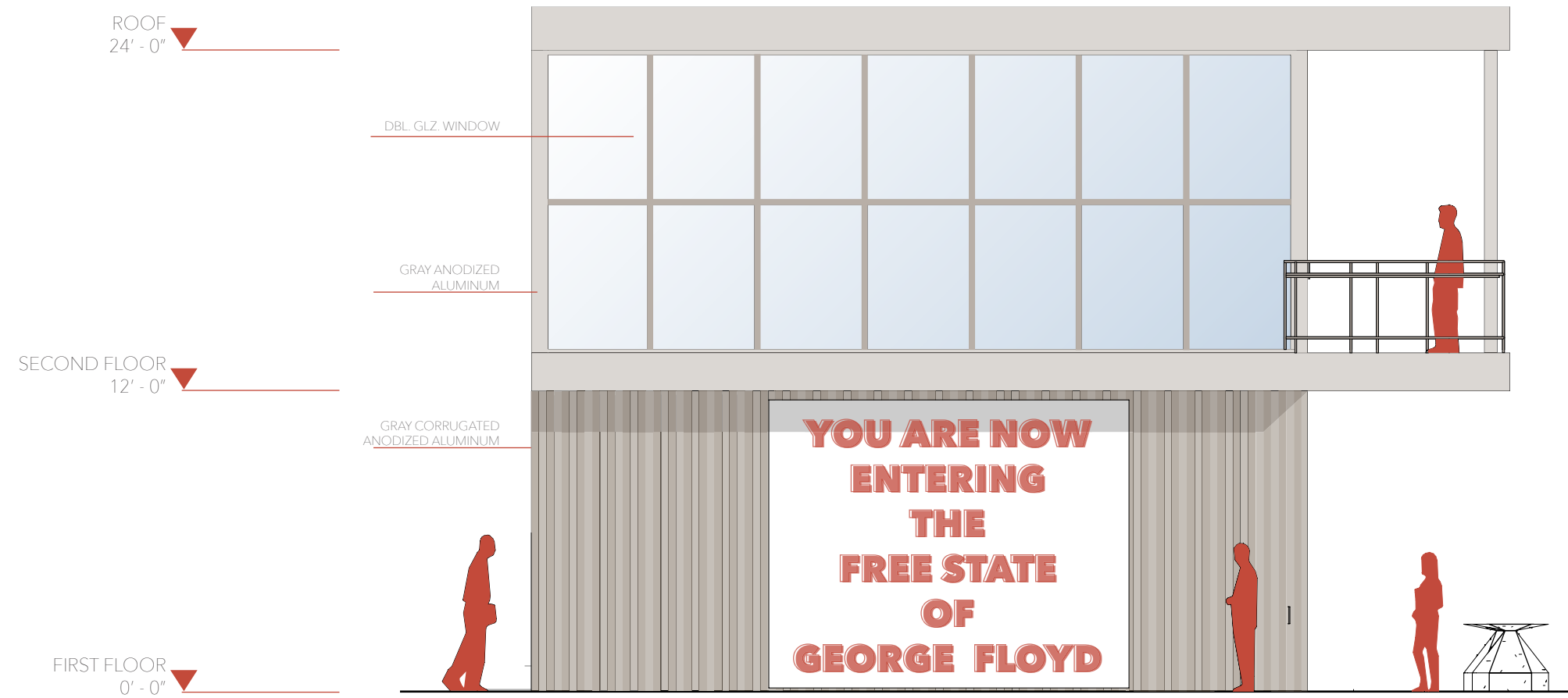

EAST ELEVATION



EAST ELEVATION

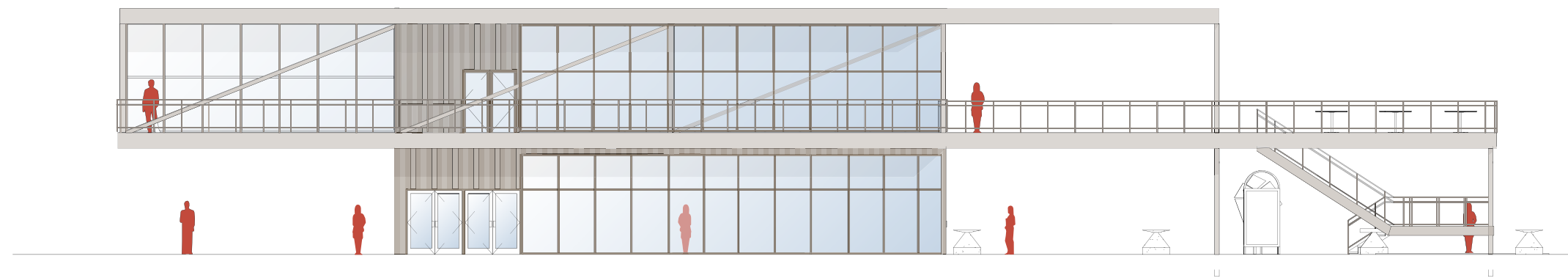

NORTH ELEVATION

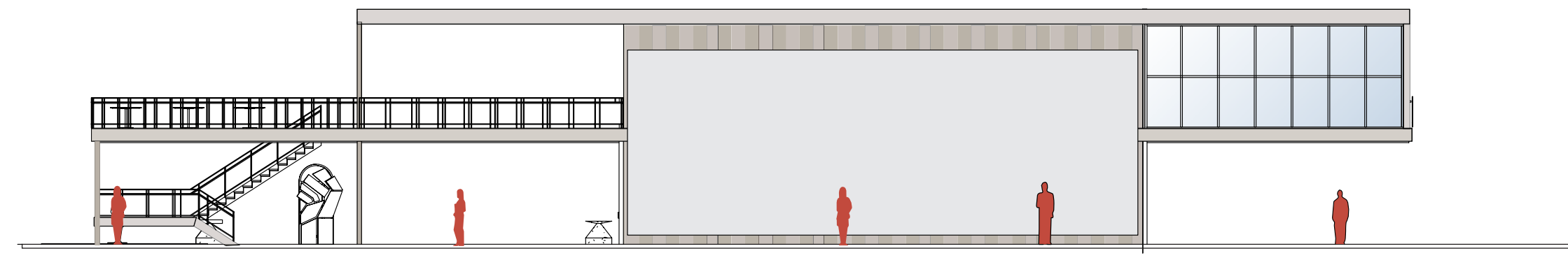

SOUTH ELEVATION



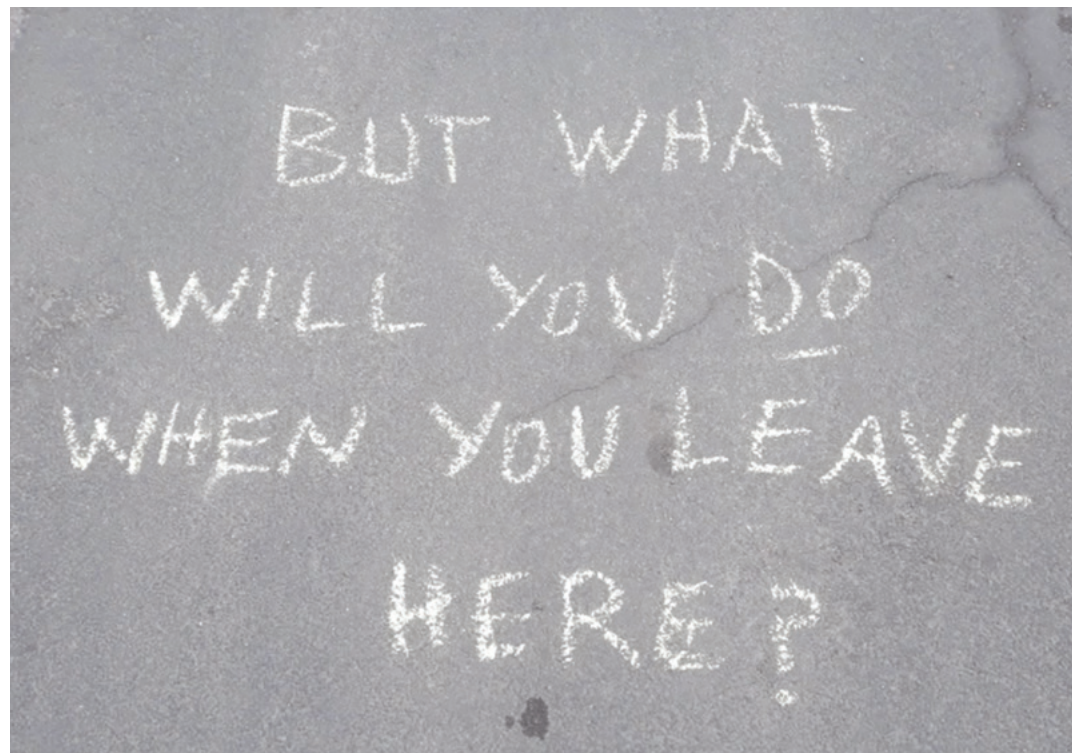

REFLECTION

This project offered me the opportunity to express the issues that are important to me publicly and freely to further explore the difficulties that over 5.8 million people in the U.S encounter on a daily basis. As I dug deeper into the research and came into contact with the innumerable stories, unjust treatment, and, at times outrageous statistics, I became enraged at the institutionalized systemic failures regarding race and equality that have permeated the United States from its inception. This effort, however, proved to be a form of therapy for me in my own way of resisting by speaking out about the issues the media doesn't always fully cover. I was able to convey and explore the immense size, cultural, societal, and sociological effect that architecture can have, as well as the responsibility that I have as a conscious designer to reinvent the built environments in favor of the people who live in it.

This was by no means an easy experience; at times, I succumbed to my own doubts, uncertainties, and emotions as I hoped I did not only do the victims justice, but their families as well because I know first hand how they feel. Beginning with the first time I considered my final study topic, I had no idea the impact it would have on me as a designer and makeshift community activist I have blossomed into. I have evolved immensely as a more confident and grounded architect, and discovered my love of combining interdisciplinary practices to better serve a community. I know now that architecture can not be a passive practice, and we must act as social activists to impact the world around us. I am excited to continue discovering who I am as a creative thinker and as a person, and I am certain that the work I offer to the field will be meaningful regardless of the size of intervention, or the number of people impacted.

Levi Harrington , 23
Apr. 3, 1882 | Lynched - Kansas City, MO

Will Brown, 41
Sept. 28, 1919 | Lynched - Omaha, NE

Eugene Williams
1919 | Killed While Protesting - IL

Dr. Andrew C. Jackson, 42
June 1, 1921 | Murdered - Tulsa, OK

Recy Taylor
1944

Thomas Shipp, 19
1930 | Lynched

Eugene Williams
1931 | AL

Hayward Patterson
1936 | AL

George Stinney Jr., 14
June 16, 1944 | Executed - Columbia, SC

Malcolm Wright, 48
July 2, 1949 | Lynched - Houston, MS

Della McDuffie, 63
Apr. 26, 1953 | Killed In Home - Alberta, AL

William McDuffie, 77
May 11, 1954 | Seeking Justice - Alberta, AL

Emmett Till, 14
August 28, 1955 | Lynched - Money, MS

John Earl Reese, 16
Oct. 23, 1955 | Long View, TX

Herbert Lee, 49
Sept. 25, 1961 | Liberty, MS

Medgar Evers, 37
June 12, 1963 | Jackson, MS

Louis Allen, 44
Jan. 31, 1964 | Liberty, MS

James Earl Chaney, 21
June 21, 1964 | Philadelphia, MI

Jimmie Lee Jackson, 26
Feb. 26, 1965 | Killed While Protesting
Selma, AL

Alberta Odell Jones, 34
Aug. 5, 1965 | Murdered - Louisville, KY

Henry Dumas, 34
May 23, 1968 | Shot- Harlem, NY

Fred Hampton, 21
Dec. 4, 1969 | Murdered - Chicago, IL

Phillip L. Gibbs, 22
May 15, 1970 | Shot - Jackson, MS

James E. Green, 27
May 15, 1970 | Shot - Jackson, MS

Elton Hayes, 17
Oct. 15, 1971| In Custody - Memphis, TN

Rita Lloyd, 17
Jan. 27, 1973 | Shot - New York City, NY

Edward Gardener, 15
Oct. 3, 1974 | Murdered - Memphis, TN

Randolph Evans, 15
Nov. 25, 1976 | Shot In Head- Brooklyn, NY

Arthur Miller Jr., 35
June 14, 1978 | Choke hold/Strangled
Brooklyn, NY

Eula Mae Love, 40
Jan. 3, 1979 |Shot - Los Angeles, CA

Michael Stewart, 25
Sept. 15, 1983 | Brutal Force - New York, NY

Eleanor Bumpers, 56
Oct. 29, 1984 | Shot - Bronx, NY

Sharon Walker, 33
Dec. 9, 1984 | Shot - Queens - NY

Yvonne Smallwood, 27
Dec. 9, 1987 | Severely Beaten - New York, NY

Mary Mitchell, 41
Nov. 3, 1990 | Murdered - Bronx, NY

Nicholas Heyward Jr., 13
Sept. 27, 1994 | New York, NY

Frankie A. Perkins, 37
Mar. 22, 1997 | Brutal Force/Strangled
Chicago, IL

Dannette Daniels, 31
June 7, 1997 | Shot - Newark NJ

Tyisha Shenee Miller, 19
Dec. 28, 1998 | Shot - Riverside, CA

Margaret L. Mitchell, 54
May 21, 1999 | Shot - Los Angeles, CA

Amadou Diallo, 24
Feb. 4, 1999 | Shot - Bronx, NY

LaTanya Haggerty, 26
June 4, 1999 | Shot - Chicago, IL

Ricky Byrdsong, 43
July 3, 1999 | Skokie, IL

Malcolm Ferguson, 24
Mar. 1, 2000 | Shot - Bronx, NY

Patrick M. Dorismond, 23
Mar. 16, 2000 | Shot - New York City, NY

Prince C. Jones Jr., 25
Sept. 1, 2000

Earl Murray, 36
June 12, 2000 | Shot - Dell Wood, MO

Ronald Beasley, 36
June 12, 2000 | Shot - Dell Wood, MO

Timothy D. Thomas Jr., 20
Apr. 7, 2001| Cincinnati, OH

Nelson M. Mendez, 24
Aug. 8, 2001 | Bellevue, WA

Orlando Barlow, 29
Feb. 28, 2003 | Las Vegas, NV

Kendra Sarie James, 22
May 5, 2003 | Shot - Portland, OR

Alberta Spruill, 57
May 16, 2003 | New York, NY

Ousmane Zongo, 43
May 22, 2003 | New York , NY

Timothy Stansbury, Jr., 20
Jan. 24, 2004 | Brooklyn, NY

Anthony Dwain Lee, 39
Oct. 28, 2000 | Los Angeles, CA

Ronald Curtis Madison, 40
Mar. 1, 2005 | Shot - Danziger Bridge, LA

Henry "Ace" Glover, 32
Sept. 2, 2005 | Shot - New Orleans, LA

James B. Brissette Jr., 18
Sept. 4, 2005 | Danziger Bridge, LA

Ronald C. Madison 56
Sept. 4, 2005 | Danziger Bridge, NO

Kathryn Johnston, 92
Nov. 21, 2006 | Atlanta, GA

Sean Bell, 23
Nov. 25, 2006 | Shot - Queens, NY

DeAunta Terrel Farrow, 13
June 22, 2007 | Shot - West Memphis, AK

Tarika Wilson, 27
Jan. 4, 2008 | Shot - Lima, OH

Oscar Grant III, 23
Jan. 1, 2009 | Shot - Oakland, CA

Shem Walker, 39
July 11, 2009 | Shot - Brooklyn, NY

Victor Steen, 19
Oct. 3, 2009 | Tasered/Run Over
Pensacola, FL

Kiwane Carrington, 15
Oct. 9, 2009 | Shot - Champaign, IL

Aaron Campbell, 26
Jan. 29, 2010 | Shot - Portland, OR

Steven Eugene Washington, 28
Mar. 20, 2010 | Shot - Los Angeles, CA

Marvin Parker, 52
Sept. 7, 2008 | Kansas City, MO

Julian Alexander, 20
Oct. 29, 2008 | Anaheim, CA

Aiyana M. Stanley Jones, 8
May 16, 2010 | Shot in head - Detroit, MI

Alonzo Ashley, 29
July 18, 2011 | Tasered - Denver, CO

Trayvon Martin, 17
Feb. 26, 2012 | Shot - Miami, FL

Nehemiah Dillard, 30
Mar. 5, 2012 | Tasered - Gainesville, FL

Shereese Francis, 30
Mar. 15, 2012 | Suffocated - Queens, NY

Rekia Boyd, 22
Mar. 21, 2012 | Chicago , IL

Tamon Robinson. 27
Apr.18, 2012 | Run over - Brooklyn, NY

Chavis Carter, 21
July 28, 2012 | Shot - Jonesboro, AR

Tyree Bell, 31
Jan. 1, 2013 | Shot - Omaha, NE

Kayla Moore, 42
Feb.13, 2013 | Restrained - Berkeley, CA

Danroy "DJ" Henry Jr., 20
Oct. 17, 2010 | Shot - Pleasant Ville, NY

Derrick Jones,37
Nov. 8, 2010 | Shot - Oakland, CA

Eugene Ellison, 67
Dec. 9, 2010 | Little Rock, AR

Reginald Doucet, 26
Jan. 14, 2011 | Shot - Los Angeles, CA

Raheim Brown, Jr., 21
Jan. 22, 2011 | Shot - Oakland, CA

Robert Ricks, 23
Feb. 6, 2011 | Alexandria, LA

Derek Williams, 21
July 6, 2011 | Blunt Force/Respiratory
Distress Milwaukee, WI

Cletis Williams, 57
Oct. 31, 2011 | Jonesboro, AR

Kenneth Chamberlain Sr., 68
Nov.19, 2011 |Tasered/Shot -White Plains,NY

Willie Ray banks, 52
Dec. 29, 2011 | Granite Shoals, TX

Ramarley Graham, 19
Feb. 2, 2012 | Shot - Bronx, NY

Manual Levi Loggins Jr., 32
Feb. 7, 2012 | San Clemente, CA

Johnnie Kamahi Warren, 46
Feb. 13, 2012 | Tasered/Electrocuted
Dothan, AL

Raymond Luther Allen Jr., 34
Feb. 29, 2012 | Tasered/Electrocuted
Galveston, TX

Wendell James Allen, 21
Mar. 7, 2012 | Shot - New Orleans, LA

Jersey K. Green, 38
Mar. 12, 2012 | Tasered/Electrocuted
Aurora, IL

Rekia Boyd, 23
Mar. 21, 2012 | Shot - Chicago, IL

Ervin Lee Jefferson, III, 18
Mar. 24, 2012 | Shot - Atlanta, GA

Kendrec McDade, 20
Mar. 24, 2012 | Shot - Pasadena, CA

Sharmel T. Edwards, 50
Apr. 21, 2012 | Shot - Las Vegas, NV

Darius Simmons, 13
May 13, 2012 | Milwaukee, WI

Shantel Davis, 23
June 14, 2012 | Shot - New York City, NY

SGT. James Brown, 26
July 15, 2012 | Police Custody - El Paso, TX

Alesia Thomas, 35
July 22, 2012 | Brutal Force/Beaten
Los Angeles, CA

Reynaldo Cuevas, 20
Sept. 7, 2012 | Shot - The Bronx, NY

Mohamed Bah, 28
Sept. 25, 2012 | New York, NY

Noel Palanco, 23
Oct. 4, 2012 | Shot - Queens, NY

Jordan Davis, 17
Nov. 23, 2012 | Jacksonville, FL

Malissa Williams, 30
Nov. 29, 2012 | 139 Rounds / Shot 23 Times
Cleveland, OH

Timothy Russel, 44
Nov. 29, 2012 | 139 rounds / Shot 23 Times
Cleveland, OH

Shelly Marie Frey, 27
Dec. 6, 2012 | Shot - Houston, TX

Darnisha Diana Harris,16
Dec. 2, 2012 | Breaux Bridge, LA

Jamaal Moore Sr., 23
Dec. 15, 2012 | Shot - Chicago, IL

Corey Stingley, 16
Dec. 29, 2012 | Milwaukee, WI

Kimani "KiKi" Gray,13
Mar. 9, 2013 | Shot - Brooklyn, NY

Clinton R. Allen, 25
Mar. 10, 2013 | Tasered/Shot - Dallas, TX

Khari Neville Illidge, 25
Mar. 24, 2013 Tasered/Electrocuted
Phoenix City, AL

Gabriel Winzer, 25
Apr. 27, 2013 | Kaufman County, TX

Deion Fludd, 17
July 12, 2013 | New York City, NY

Kyam Livingston, 38
July 21, 2013 | Ignored Pleas For Help
New York, NY

Larry Eugene Jackson Jr., 33
July 26, 2013 | Shot - Austin, TX

Denis Reynoso, 30
Sept. 5, 2013 | Shot - Lynn, MA

Alexander Jamar Marion, 19
Sept. 29, 2013 | Shot - Asheville, NC

Michael Blair 26
Nov. 4, 2013 | Shot - Richmond, TX

Willie James Williams, 27
Nov. 13, 2013 | Shot - Columbus, GA

Kenneth R. Herring, 50
Dec. 12, 2013 | Columbus, OH

Gregory Lewis Towns Jr., 24
Apr. 11, 2014 | Tasered/Electrocuted
East Point, GA

Joseph Givens, 34
May 10, 2014 | Shot - Columbus, OH

Thomas Dewitt Johnson, 28
June 4, 2014 | Shot - Jacksonville, FL

Michelle Cusseau, 50
Oct. 14, 2014 | Shot - Phoenix, AZ

Jeffery B. Lilly Jr., 22
Aug. 8, 2013 | Tasered/Electrocuted
Indianapolis, IN

Carlos Alcis, 43
Aug. 15, 2013 | Heart Attack/ - Brooklyn, NY

Jonathan Ferrell, 24
Sept. 14, 2013 | Shot - Charlotte, NC

Barrington "BJ" Williams, 25
Sept. 17, 2013 | Neglect/Disdain/Asthma
Attack - New York, NY

Miriam Iris Carey, 34
Oct. 3, 2013 |Shot 26 Times - Washington, DC

Andy Lopez, 13
Oct. 22, 2013 | Shot - Santa Rosa, CA

Renisha McBride, 19
Nov. 2, 2013 | Dearborn Heights, MI

Jordan Baker, 26
Jan. 16, 2014 |Shot - Houston, TX

McKenzie J. Cochran, 26
Jan. 29, 2014 | Pepper Sprayed/
Compression Asphyxiation
Southfield, MI

Yvette Smith, 48
Feb. 16, 2014 |Shot-Bastrop County, TX

Marquise Jones, 23
Feb. 28, 2014 | San Antonio, TX

Gabriella Monique Nevarez, 23
Mar. 2, 2014 | Shot - Citrus Heights, CA

Victor White III, 23
Mar. 3, 2014 | Shot In Police Custody
New Iberia, LA

Dontre Hamilton, 31
Apr. 30, 2014 | Shot - Milwaukee, WI

Micheal brown 18
Aug. 19, 2014 | Shot - Ferguson, MI

Tamir Rice
Nov. 14, 2014 | Shot - Cleveland, OH

Andre Larone Murphy Sr., 42
Jan. 7, 2015 | Brutal Force - Omaha, NE

Yvette Henderson, 38
Feb. 3, 2015 | Shot - Emeryville, CA

Nathan McKenna, 37
Feb. 7, 2015 | Tasered - Alexandria, VA

Monique Jenee Deckard, 43
Mar. 9, 2015 | Shot - Anaheim, CA

Alexia Christian, 25
Apr. 29, 2015 | Shot - Atlanta, GA

Ronell Wade, 45
May 16, 2015 | Brutal Force/Strangle
Harvey, IL

Jonathan Sanders, 39
July 8, 2015 | Brutal Force/Strangled
Stonewall , MA

Rakeem Bentley, 25
Jan. 15,2016 | Shot - Southfeild, MI

Alton Sterling, 37
July 5, 2016 | Shot - Baton Rouge, LA

Joseph Curtis Mann, 50
July 11, 2016 | Shot - Sacramento, CA

Korryn Gaines, 23
Aug. 1, 2016 | Shot -Randallstown, MA

Terrence LeDell Sterling, 31
Sept. 11, 2016 | Shot - Washington, DC

Terence Crutcher, August 40
Sept. 16, 2016 | Shot - Tulsa, OK

Philando Castile, 32
July 6, 2016 | Falcon Heights, MN

Joseph Mann, 51
July 11, 2016 | Sacramento, CA
Donnell Thompson Jr., 27
July 28, 2016 | Compton, CA

Jamarion Robinson, 26
Aug. 5, 2016 | East Point, GA

Christian Taylor, 19
Aug. 7, 2016 | Forth Worth, TX

Terence Crutcher
Sept. 16, 2016 | Tulsa, OK

Alfred Olango, 38
Sept. 27, 2016 | El Cajon, CA

Deborah Danner, 66
Oct. 18, 2016 | Shot - The Bronx, NY

Chad Robertson, 25
Feb. 8, 2017 | Shot - Chicago, IL

Desmond Phillips, 25
Mar. 17, 2017 | Chico, CA

Alteria Woods, 21
Mar. 19, 2017 | Gifford, FL

Jordan Edwards, 16
Apr. 29, 2017 | Shot - Balch Springs, TX

Charleena Chavon Lyles, 29
June 18, 2017 | Shot - Seattle, WA

Aaron Bailey, 35
June 29, 2017 | Shot -Indianapolis, IN

Charleena Lyles, 30
June 18, 2017 | Seattle, WA

India Nelson, 25
July 17, 2017 | Shot - Norfolk, VA

Bijan Ghaisar, 25
Nov. 27, 2017 | Shot - Alexandria, VA

Dennis Plowden Jr., 25
Dec. 28, 2017 | Shot - Philadelphia, PA

Jarvis Lykes, 35
Dec. 31, 2017 | Shot - Columbus, GA

Jonathan Bennett, 32
Jan. 11, 2018 | Charlotte, NC

Thomas Dewitt Johnson, 28
Jan 24, 2018 | Shot - Jacksonville, FL

Daniel O. El, 33
Feb. 1, 2018 | Shot - Peorai, IL

Ronell Foster, 33
Feb. 13, 2018 | Vajello, CA

Stephon Alonzo Clark, 23
Mar. 18, 2018 | Shot - Sacramento, CA

Saheed Vassell, 35
Apr. 4, 2018 | Shot - Brooklyn, NY

Willie Rogers Marable 29
May 13, 2018 | Shot - Portsmouth, VA

Antwon Rose Jr., 18
June 19, 2018 | Shot - East Pittsburgh, PA

Marlin Mack, 25
July 15, 2018 | Shot - Kansas City, MO

Robert Knox, 50
Aug. 28, 2018 | Shot - Harbeson, DE

Botham Shem Jean, 27 -
Sept. 6, 2018 | Shot - Dallas, TX

Anton Milbert LaRue Black, 20
Sept. 15, 2018 | Tasered/Sudden Cardiac Arrest - Greensboro, MA

Lajuana Phillips, 36
Oct. 2, 2018 | Tasered/Execrocuted Victorville, CA

Chinedu Okobi, 36
Oct. 3, 2018 | Tasered/Execrocuted Millbrae, CA

Charles “Chop” Roundtree Jr., 18
Oct. 17, 2018 | Shot - San Antonio, TX

Emantic Fitzgerald Bradford Jr., 21
Nov. 22, 2018 | Shot - Hoover, AL

Aleah Jenkins, 24
Nov. 27, 2018 | In custody - La Jolla, CA

Jarvis Randall, 30
Dec. 1, 2018 | Shot - Tamarac, FL

Gregory Lloyd Edwards, 38
Dec. 10, 2018 | Kneled, Punched, Pepper Sprayed, Tasered,Strapped Into A Restraint Chair With Spit Hood Over Head/Failure To Provide Medical Care. Brevard County, FL

April E. Webster, 47
Dec. 16, 2018 | Shot - Darlington, SC

Michael Jerome Taylor 17,
Dec. 25, 2018 | Shot - Lakeland, FL

Brandon Lovell Webster, 28
Jan.1, 2019 | Shot - Shallotte, NC

Isaiah Thomas, 40
Feb. 2, 2019 | Shot - Stockton, CA

Jassmine McBride, 30
Feb. 12, 2019 | Flint, MI

Bradley Blackshire, 30
Feb. 22, 2019 | Little Rock, AR

Rodney Lassister, 30
Mar. 9, 2019 | Shot -Monahans, TX

Sterling Lapree Higgins, 37
Mar. 25, 2019 | Choke Hold/Asphyxiation Union City, TN

Javier Ambler, 41
Mar.28, 2019 | Tasered/Execrocuted Austin, TX

Kawaski Trawick, 32
Apr. 14, 2019 | Shot - The Bronx, NY

Alexia Christian, 25
Apr. 29, 2019 | Shot - Atlanta, GA

Ronald Greene, 60
May 10, 2019 | Stun Gun/ Force Monroe, LA

Paula Turner,44
May 13, 2019 | Baytown, TX

Dominique Clayton, 32
May 19, 2019 | Oxford, MS

DeWayne Watkins, 74
June 18, 2019 | Shot - Syracuse, NY

Isak Abdirahman Aden, 23
July 2, 2019 | Shot - Egan, MN

Ronald Greene, 50
May 10, 2019 | Stun Gun/ Force - Monroe, LA

Jaleel Medlock, 21
July, 16, 2019 | In Custody - Conway, AR

Shawan F. Allen, 17
July 23, 2019 | Brutal Force/ Strangled Wesson , MA

Elijah McClain, 23
August 30, 2019 | Choke hold/Ketamine/ Heart Attack - Aurora, Colorado

Byron Williams, 50
Sept. 5, 2019 | Las Vegas, NV

Atatiana Jefferson, 28
Oct. 12, 2019 | Fort Worth, TX

Michael Dean, 28
Dec. 2, 2019 | Temple, TX

Atatiana Koquice Jefferson, 19
Oct. 12, 2019 | Fort Worth, TX

John Elliot Neville, 57
Dec. 4, 2019 | Asphyxiated (Hog-Tied in Prone Position)/Heart Attack/Brain Injury Winston- Salem, NC

Jamarri Daiwon Tarver, 26
Jan. 1, 2020 | Shot - Las Vegas, NV

Miciah Lee, 18
Jan. 5,2020 | Sparks, NV

William Howard Green, 44
Jan. 27, 2020 | Shot - Temple Hills, MD

Jaquyn O’Neill Light, 20
Jan. 28, 2020 | Graham, NC

Lionel Morris, 39
Feb. 4, 2020 | In Custody - Conway, AR

Jeremy Grayson, 31
Feb. 9, 2020 | Shot - Chicago, IL

Kevin Aldophe 22
Feb. 18, 2020 | Shot - Orlando, FL

Ahmaud Arbery, 25
Feb. 23, 2020 | Satilla Shores, GA

Reginald “Reggie” Payne, 48
Mar. 3, 2020 | Sacramento, CA

Manuel “Mannie” Elijah Ellis, 34
Mar. 3, 2020 | Physical Restraint/Hypoxia Tacoma, WA

Barry Gedeus, 27
Mar. 8 2020 | Fort Lauderdale, FL

Breonna Taylor, 27
Mar.13, 2020 | Shot - Louisville, KT

Daniel T. Prude, 42
Mar. 30, 2020 | Asphyxiation Rochester, NY

Steven Taylor, 33
Apr. 16, 2020 | San Leandro, CA

Michael Brent Charles Ramos, 42
Apr. 24, 2020 | Shot - Austin, TX

Cornelius Fredricks, 16
May 1, 2020 | Restrained - Kalamzoo, MI

Dreasjon “Sean” Reed, 21
May 6, 2020 | Shot - Indianapolis, IN

Maurice Gordon, 28
May 23, 2020 | Bass River, NJ

Dion Johnson, 28
May 25, 2020 | Phoenix, AZ

George Perry Floyd, 47
May 25, 2020 | Knee On Neck/Asphyxia Minneapolis, MN

Calvin Horton Jr., 43
May 27, 2020 | Minneapolis, MN

Tony “Tony the Tiger” McDade, 28
May 27, 2020 | Shot - Tallahassee, FL

James Scurlock, 22
May 30, 2020 | Omaha, NE

David McAtee, 54
June 1, 2020 | Shot - Louisville, KT

Jamel Floyd, 35
June 5, 2020 | In Custody - New York, NY

Kamal Flowers, 24
June 5, 2020 | New Rochelle, NY

Robert Forbes, 56
June 6, 2020 | Protesting Murder of George Floyd - Bakersfield, CA

Carlos Carson, 28
June 6, 2020 | Pepper Sprayed/Shot In Head Tulsa, OK

Priscilla Slater, 38
June 10, 2020 | In custody Harper Wood, MI

Rayshard Brooks, 27
June 12, 2020 | Shot - Atlanta, GA

Brayla Stone, 17
June 25, 2020 | Little Rock, AR

Maurice Abisdid - Wagner, 30
July 26, 2020 | Maui, HI

Julian Lewis, 60
Aug. 7, 2020 | Sylvania, GA

Anthony McClain, 32
Aug. 15, 2020 | Pasadena, CA

Damian Daniels, 30
Aug. 25, 2020 | San Antonio, TX

Dijon Kizzee, 29
Aug. 31, 2020 | Los Angeles, CA

Kurt Reinhold, 42
Sept. 23, 2020 | San Clemente, CA

Dijon Durand Kizzee, 29
Aug. 31, 2020 | Shot - Los Angeles,CA

Jonathan Dwayne Price, 32
Oct. 3, 2020 | Tasered/ Shot - Wolfe City, TX

Marcellis Stinnette, 19
Oct. 20, 2020 | Shot - Waukegan, IL

Walter Wallace Jr., 27
Oct. 26, 2020 | Philadelphia, PA

Kevin Petterson Jr., 21
Oct. 29, 2020 | Vancouver, WA

Quawan Charles, 15
Nov. 3, 2020 | Iberia Parish, LA

Sincere Pierce,18 -
Nov. 13, 2020 | Shot - Cocoa, FL

Angelo “AJ” Crooms, 16
Nov. 13, 2020 | Shot - Cocoa, FL

Aiden Ellison , 19
Nov. 23, 2020 | Ashland, OR

Casey Goodson Jr., 23
Dec. 4, 2020 | Columbus, OH

Bennie Edwards, 60
Dec. 11, 2020 | Oklahoma City, Ok

Monica Goods, 11
Dec. 22, 2020 | Ulster, NY

Andre Maurice Hill, 47
Dec. 22, 2020 | Shot - Columbus, OH

Angelo Quinto, 20 -
Dec. 26, 2020 | Knee On Neck/Asphyxiated Antioch, CA

Robert Howard, 30
Jan. 5, 2021 | Kidnapped/Murdered Memphis, TN

Vincent “Vinny” M. Belmonte, 20
Jan. 5, 2021 | Shot - Cleveland, OH

Xzavier Hill, 18
Jan. 9, 2021 | Goochland County, VA

Patrick Lynn Warren Sr., 53
Jan. 10, 2021 | Shot -Killeen, TX

*** Tyree Rodgers, 39**
Jan. 25, 2021 | Wichita Falls , TX

Jenoah Donald, 38
Feb. 9, 2021 | Hazel Dell, WA

Donald Francis Hairston 44
Feb. 25, 2021 | Tasered/Execrocuted/Shot Culpeper, VA

Jehlani Black, 19
Mar. 9, 2021 | Shot - Riverside, CA

Marvin David Scott III, 26
Mar. 14, 2021 | Pepered Sprayed/ Restrained with spit hood/Asphyxiated McKinney, TX

Donovon Lynch, 25
Mar. 26, 2021 | Virginia Beach, VA

Dominique Williams, 32
Apr. 7, 2021 | Takoma Park, MD

Daunte Demetrius Wright, 21 -
Apr. 11, 2021 | Shot - Brooklyn Center, MN

Matthew “Zadok” Williams, 35
Apr. 12 2021 | Dekalb, GA

Ryan Oneal Williams , 31
Apr. 18, 2021 | Shot -Fort Worth, TX

Ma’Khia Bryant, 16
Apr. 20, 2021 | Columbus, OH

Andrew Brown Jr., 42
Apr. 21, 2021 | Elizabeth City, NC

Latoya Denise James, 37
May 4, 2021 | Woodbine, GA

Adonis Traughber, 54 -
May 8, 2021 | Shot - Clarksville, TN

Winston Smith, 32
June 3, 2021 | Minneapolis, MN

Briana Sykes, 19
June 19, 2021 | Shot - Flint, MI

Ryan Leroux, 21
July 16, 2021 | Gaithersburg, MD

Leslie Stephen Scarlett 35
July 18, 2021 | Shot - Tusan, Arizona

Alvin Motley Jr., 48
Aug. 7, 2021 | Memphis, TN

Antonio Jackson, 27
Aug. 16, 2021 | Shot - Memphis, TN

Fanta Bility, 8
Aug. 27, 2021 | Sharon Hill, PA

Cedric Williams, 29
Sept. 10, 2021 | Shot - Oxon Hill, MD

Anthony Oliver, 54
Nov. 26, 2021| Tasered/Execrocuted Indianapolis, IN

Arnell “AJ” Stewart, 27
Dec. 2, 2021 | Minneapolis, MN

Michael Wayne Jackson, 62
Dec. 4, 2021 | Houston TX

Nakita Williams, 33
Dec. 19, 2021 | Shot - Detroit, MI

Thelonious McKnight, 25
Dec. 29, 2021 | Shot - Asheville, NC

James Williams, 46
Jan. 1, 2022 | Shot Threw Fence Canton, OH

Kadeem Errol Livingston Smith,28
Jan. 2, 2022 | Shot - Pine Hills, FL

James Sutton, 55
Jan. 8, 2022 | Shot - Keansburg, NJ

Jason Walker, 37
Jan. 8, 2022 | Fayetteville, NC

Isaiah Tyree Williams, 19
Jan. 10, 2022 | Shot - Las Vegas, NV

James Williams, 46
Jan. 1, 2022 | Shot Threw Fence Canton, OH

Amir Locke, 22
Feb. 2, 2022 | Minneapolis, MN

Donnell Rochester, 18
Feb. 19, 2022 | Baltimore, MD

Patrick Lyoya, 26
Apr. 4, 2022 | Grand Rapids, MI

There Are Up To 1,326
Names Not Mentioned.

REFERENCES

- [1] Burks, Megan, et al. "The Call for Justice at 38th and Chicago Persists." MPR News, MPR News, 3 Dec. 2020, <https://www.mprnews.org/story/2020/11/25/timeline-building-george-floyd-square>.
- [2] Martin, Frank Edgerton. "In Minneapolis, as George Floyd Square Is Cleared, So Too Is the Historic Landscape." *The Architect's Newspaper*, 11 June 2021, <https://www.archpaper.com/2021/06/minneapolis-george-floyd-square-is-cleared-so-too-historic-landscape/>.
- [3] Raban, Jonathan. *Soft City*. Picador, Pan Macmillan, 2017.
- [4] Bagnall G. (2003) 'Performance and Performativity at Heritage Sites' *Museum and Society*, 1(2): 87-103
- [5] Forgan, S. (2005). 'Building the Museum': Knowledge, Conflict and the Power of Place', *Isis* 96 (4) 572-85.
- [6] Gibelhausen, M. (2002) 'The Architecture is the Museum', in Marstine, J. (ed.) *New Museum Theory and Practice: An Introduction*. Blackwell: Oxford.
- [7] Jones, Paul. "Paul Jones* University of Liverpool - Semantic Scholar." Edited by Suzanne MacLeod, *Museum Architecture Matters*, *Museum Architecture Matters*, 2016, <https://pdfs.semanticscholar.org/0dc4/cca62a-08c8825a97b50831fba53d125ce5d7.pdf>.
- [8] KIM, YOUNGDUK. "EXPLORATION OF CONNECTION OF CONNECTIVITY BETWEEN URBAN PL WEEN URBAN PLAZA AND MIXED USE BUILDINGS ." University of Massachusetts Amherst ScholarWorks, University of Massachusetts, July 2015, https://scholarworks.umass.edu/cgi/viewcontent.cgi?article=1251&context=masters_theses_2.
- [9] "May 23, 1968: Acclaimed Writer Henry Dumas Fatally Shot by Police." Zinn Education Project, 24 May 2021, https://www.zinned-project.org/news/tdih/henry-dumas-shot?_keywords=say+their+names+.
- [10] "List of Unarmed Black People Killed by Police - on Monuments." Renée Ater, 29 May 2020, <https://www.reneeater.com/on-monuments-blog/tag/list+of+unarmed+black+people+killed+by+police>.
- [11] "Say Their Names List 2022 - #Saytheirnames." Say Their Names List 2022 - #SayTheirNames, <https://sayevery.name/#last>.
- [12] Left: Between 200,000 and 500,000 demonstrators march down Constitution Avenue during the March on Washington for Jobs and Freedom, Washington D.C., Aug. 28, 1963; Right: Protesters gather in Harlem to protest the recent death of George Floyd on May 30, 2020 in New York City. Hulton Archive/Getty Images; David 'Dee' Delgado—Getty Images
- [13] Demonstrators gather outside Cup Foods to celebrate the murder conviction of former Minneapolis police officer Derek Chauvin in the killing of George Floyd, Tuesday, April 20, 2021, in Minneapolis. (AP Photo/John Minchillo)
- [14] A woman posing for a photograph with name of George Floyd written in chalk on the ground in Minneapolis, Minnesota [Lucas Jackson/Reuters]