

(12) **United States Patent**  
**Alberson et al.**

(10) **Patent No.:** **US 10,851,503 B2**  
(45) **Date of Patent:** **Dec. 1, 2020**

(54) **TENSION END TREATMENT FOR GUARDRAIL SAFETY SYSTEM**

USPC ..... 256/13.1; 404/6, 7, 10  
See application file for complete search history.

(71) Applicant: **The Texas A&M University System,**  
College Station, TX (US)

(56) **References Cited**

(72) Inventors: **Dean C. Alberson,** Bryan, TX (US); **D. Lance Bullard, Jr.,** College Station, TX (US); **C. Eugene Buth,** Wellborn, TX (US); **Roger P. Bligh,** College Station, TX (US); **Akram Y. Abu-Odeh,** College Station, TX (US)

U.S. PATENT DOCUMENTS

5,775,675	A *	7/1998	Sicking	.....	E01F 15/0476
					256/13.1
6,173,943	B1 *	1/2001	Welch	.....	E01F 15/143
					256/13.1
6,554,256	B2 *	4/2003	Ochoa	.....	E01F 15/143
					256/13.1
6,719,483	B1 *	4/2004	Welandsson	.....	E01F 15/0476
					256/13.1
6,783,116	B2 *	8/2004	Albritton	.....	E01F 15/143
					256/13.1
7,694,941	B2 *	4/2010	Abu-Odeh	.....	E01F 15/143
					256/13.1
8,215,619	B2 *	7/2012	Leonhardt	.....	E01F 15/025
					256/13.1

(73) Assignee: **The Texas A&M University System,**  
College Station, TX (US)

(\* ) Notice: Subject to any disclaimer, the term of this patent is extended or adjusted under 35 U.S.C. 154(b) by 0 days.

(Continued)

(21) Appl. No.: **15/214,888**

*Primary Examiner* — Josh Skroupa

(22) Filed: **Jul. 20, 2016**

(74) *Attorney, Agent, or Firm* — Baker Botts L.L.P.

(65) **Prior Publication Data**

US 2017/0051461 A1 Feb. 23, 2017

**Related U.S. Application Data**

(60) Provisional application No. 62/195,006, filed on Jul. 21, 2015.

(51) **Int. Cl.**  
**E01F 15/14** (2006.01)  
**E01F 15/02** (2006.01)

(52) **U.S. Cl.**  
CPC ..... **E01F 15/143** (2013.01); **E01F 15/025** (2013.01)

(58) **Field of Classification Search**  
CPC ... E01F 15/025; E01F 15/0407; E01F 15/143;  
E01F 15/145; E01F 15/146; E01F 15/148

(57) **ABSTRACT**

An end treatment for a guardrail safety system includes a terminal portion of a guardrail beam comprising a downstream end and upstream end, a first tension cable coupled to an upstream end of the terminal portion. An extruder configured to receive at least a portion of the guardrail beam and at least a portion of the first tension cable, and a terminal support post installed adjacent the roadway at an upstream end of the terminal portion of the guardrail beam. The extruder includes a narrowing throat providing a channel in which at least a portion of the guardrail beam is disposed. The narrowing throat is configured to flatten the guardrail beam in response to a collision with a vehicle moving the extruder in a downstream direction along the guardrail beam. The terminal support post coupled to an upstream end of the first tension cable.

**5 Claims, 12 Drawing Sheets**

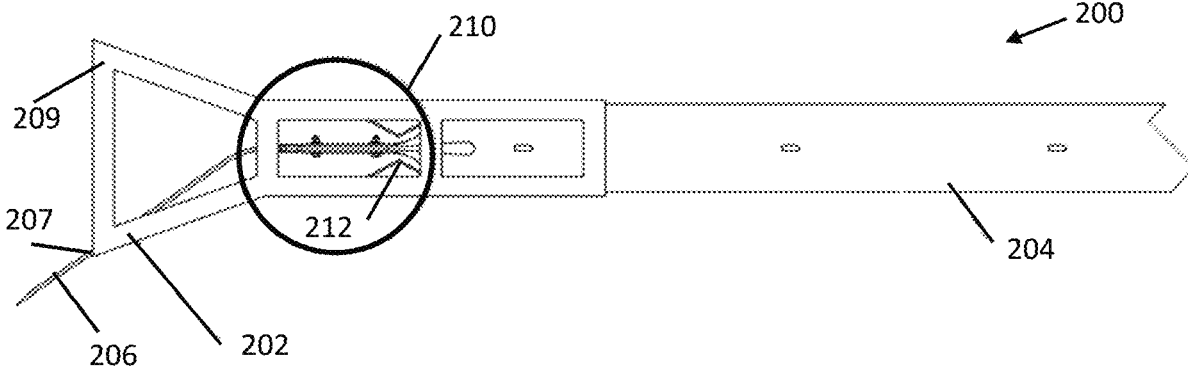

(56)

**References Cited**

U.S. PATENT DOCUMENTS

8,517,349	B1 *	8/2013	Ross	.....	E01F 15/143 256/1
8,596,617	B2 *	12/2013	James	.....	E01F 15/025 256/13.1
9,145,943	B2 *	9/2015	Sicking	.....	E01F 15/145
9,689,124	B2 *	6/2017	Harman	.....	E01F 15/143
9,714,493	B1 *	7/2017	Dyke	.....	E01F 15/0438
2003/0025112	A1 *	2/2003	Sicking	.....	E01F 15/143 256/13.1
2007/0252124	A1 *	11/2007	Heimbecker	.....	E01F 15/025 256/13.1
2012/0217459	A1 *	8/2012	Smith	.....	E01F 15/143 256/13.1
2014/0231735	A1 *	8/2014	Harman	.....	E01F 15/143 256/13.1

\* cited by examiner



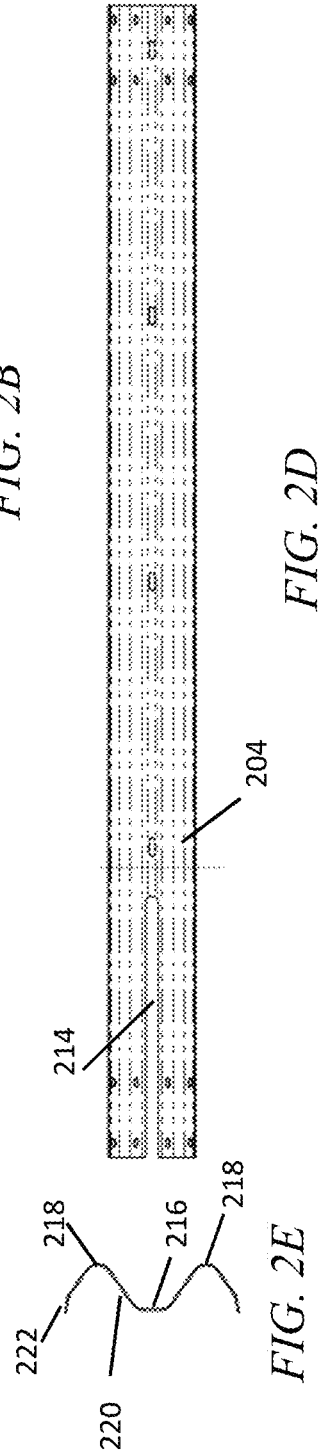
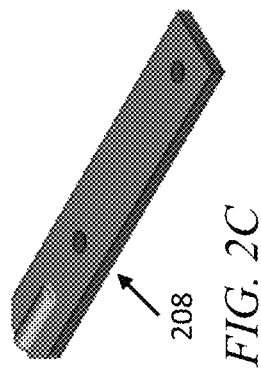
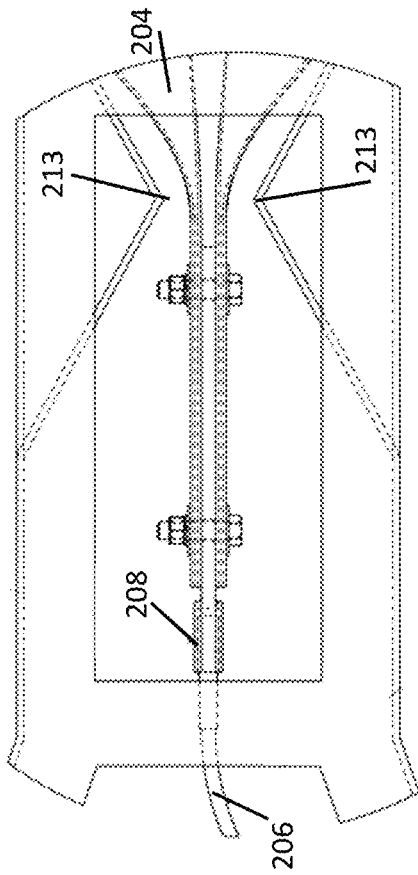
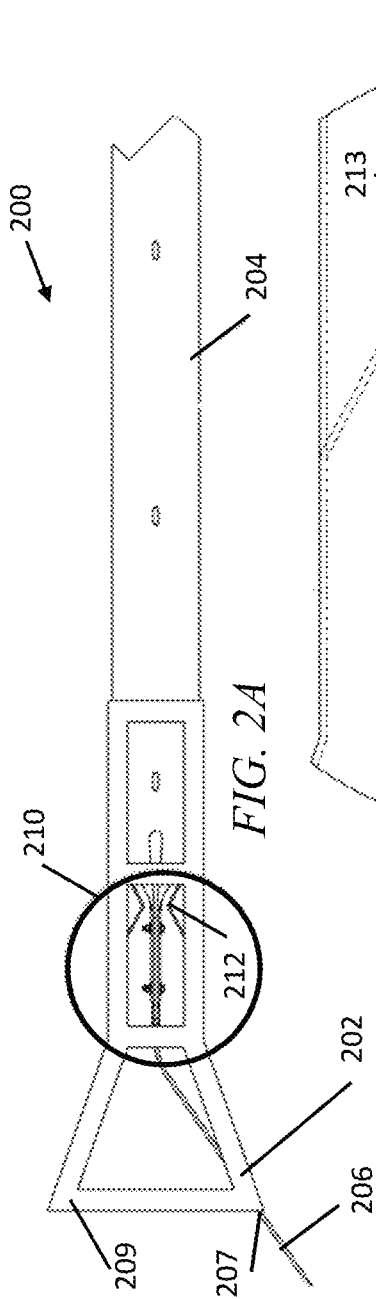

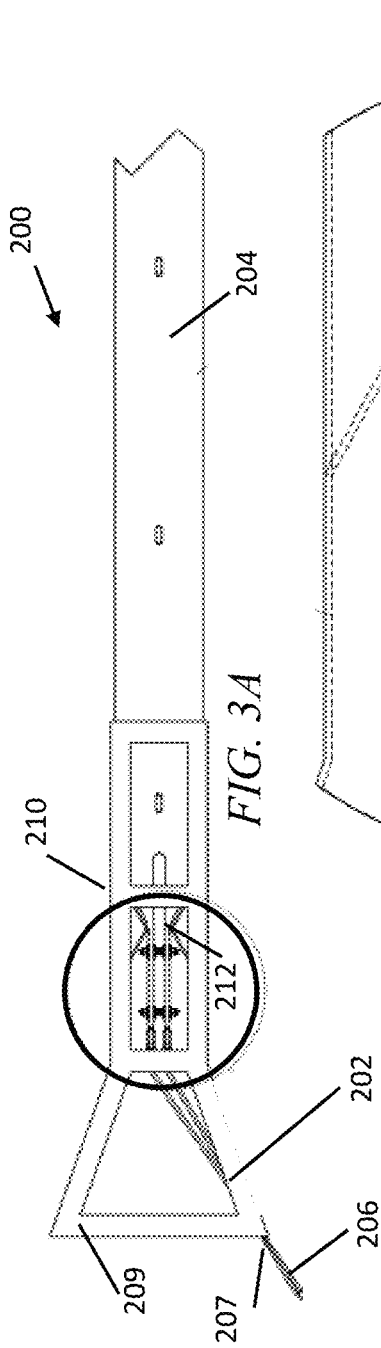

FIG. 3A

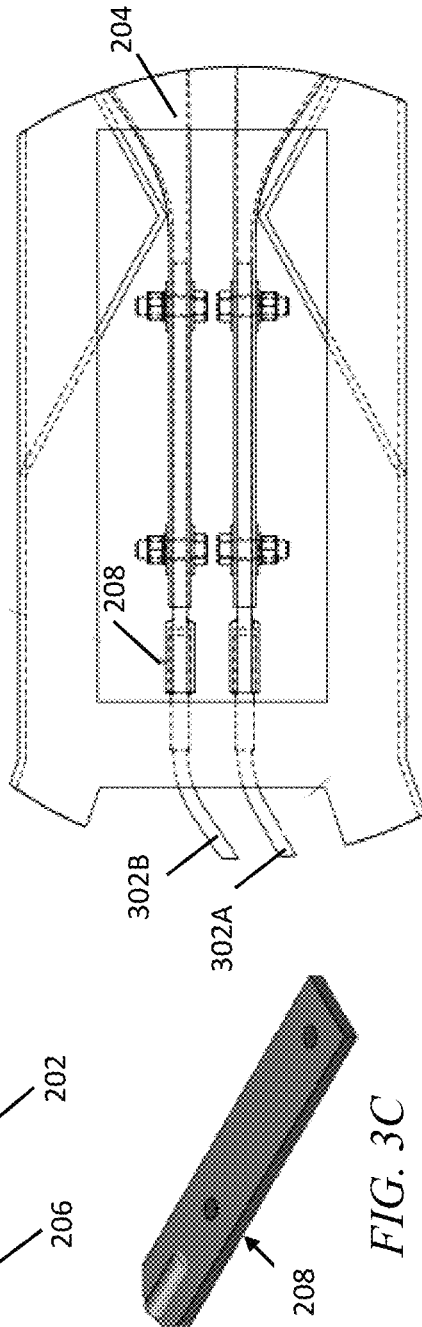

FIG. 3B

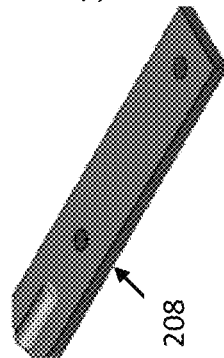

FIG. 3C

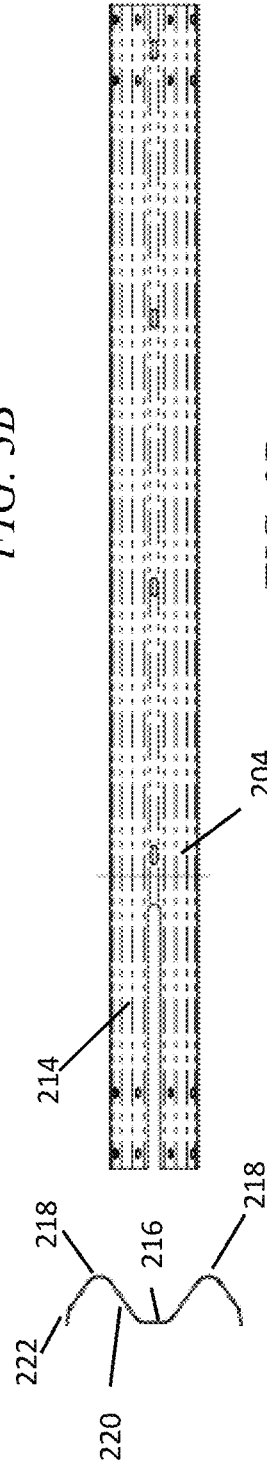

FIG. 3D

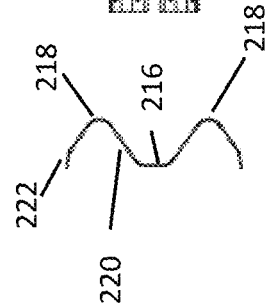

FIG. 3E

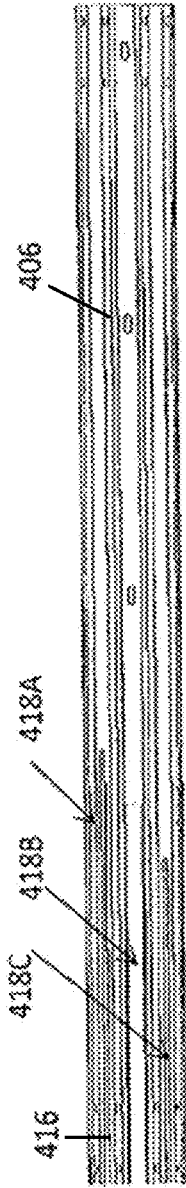

FIG. 4A

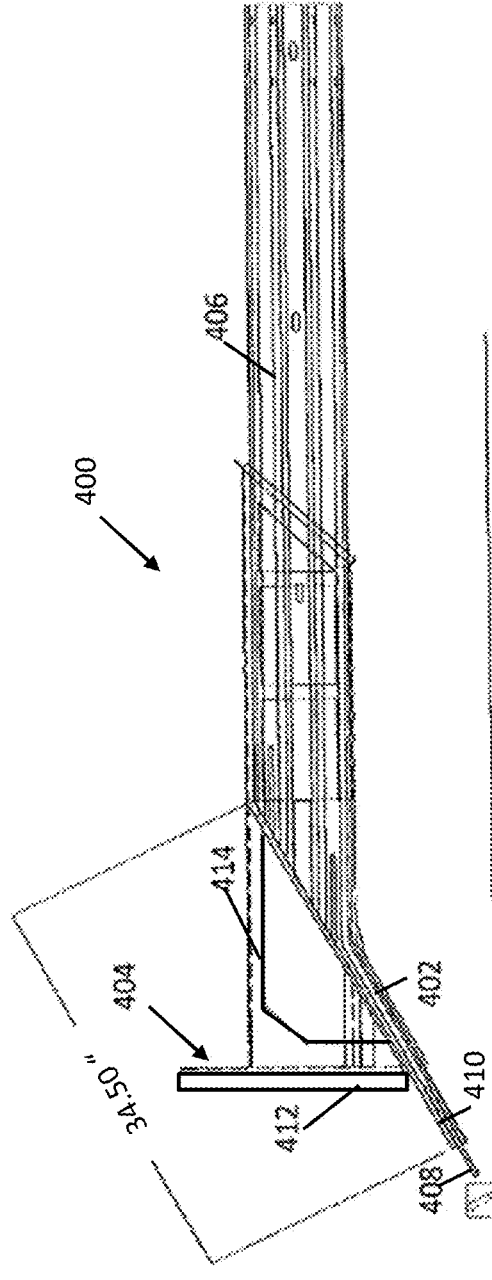

FIG. 4B

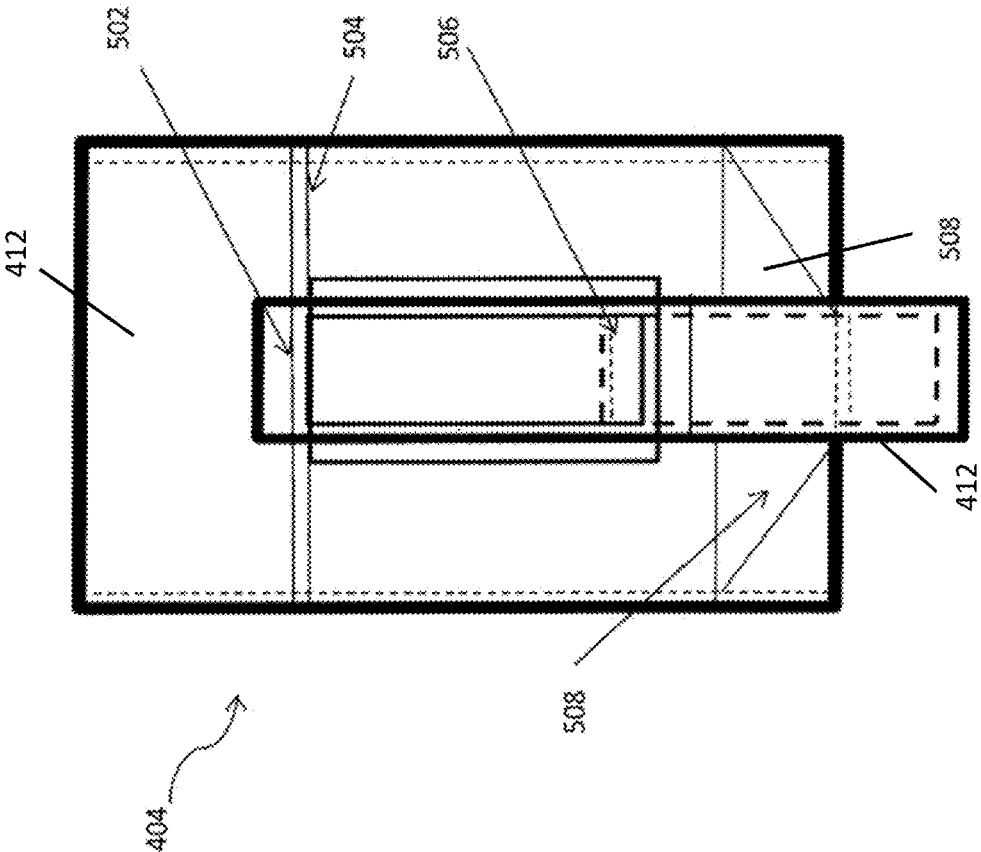

FIG. 5

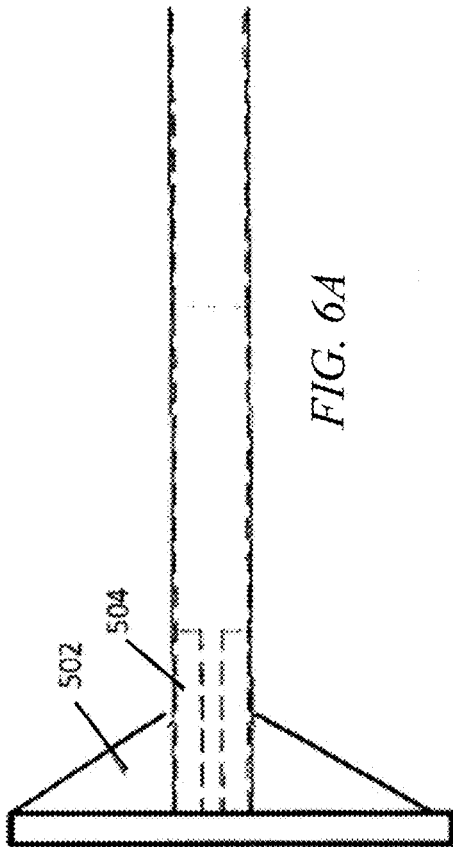

FIG. 6A

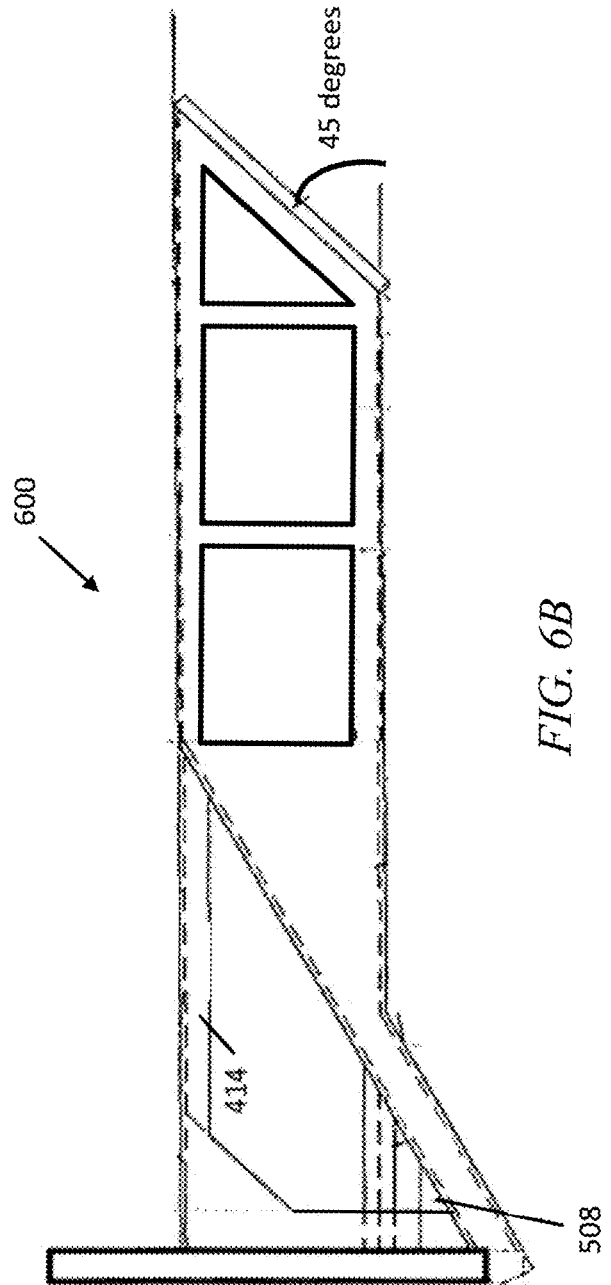

FIG. 6B



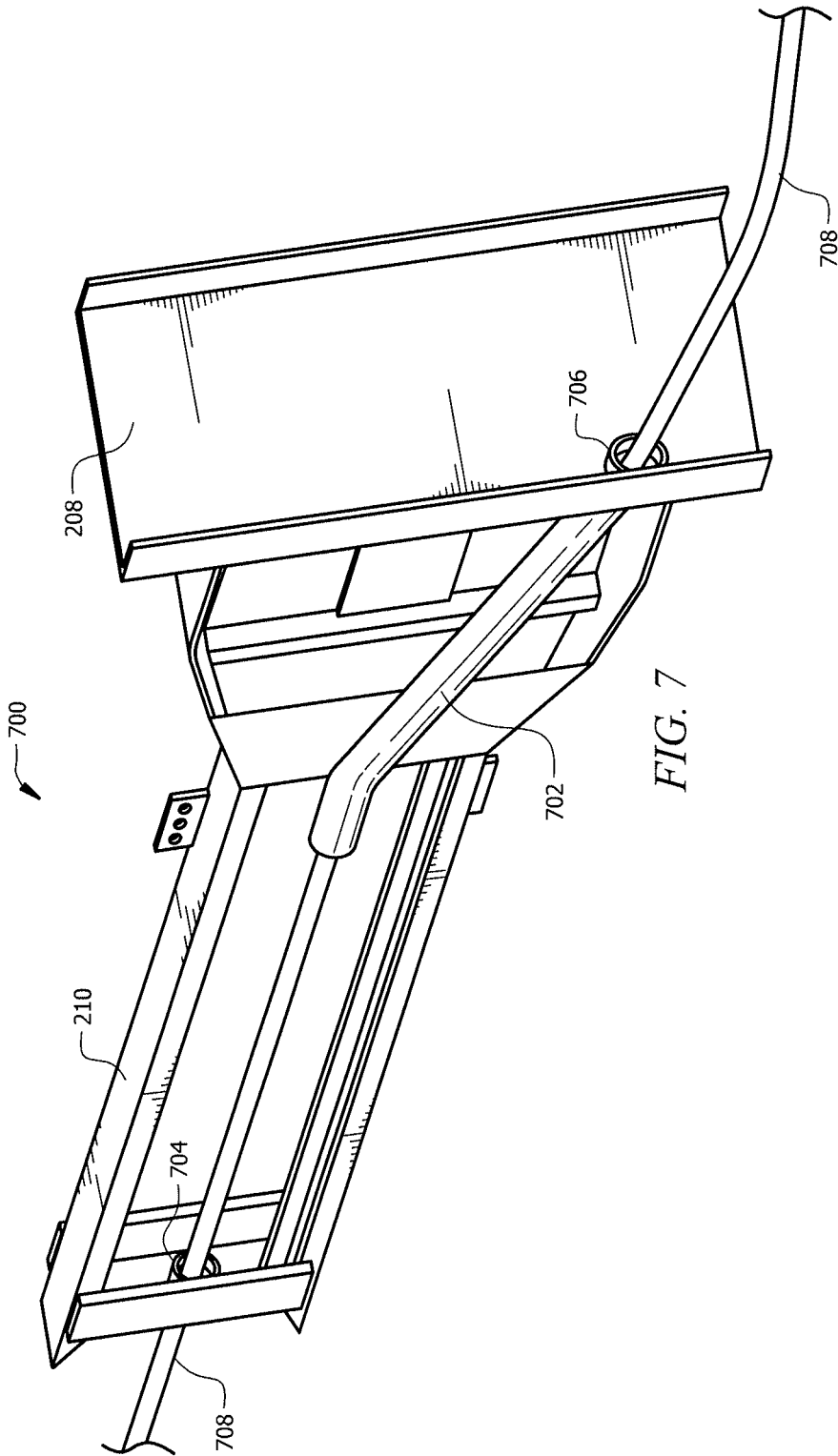
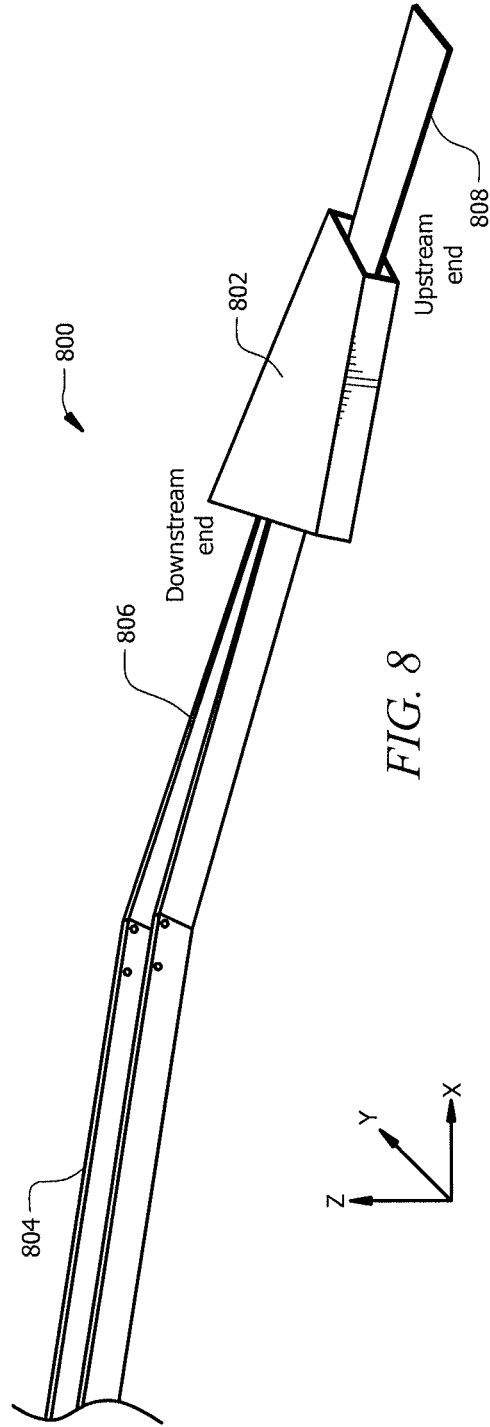

FIG. 7



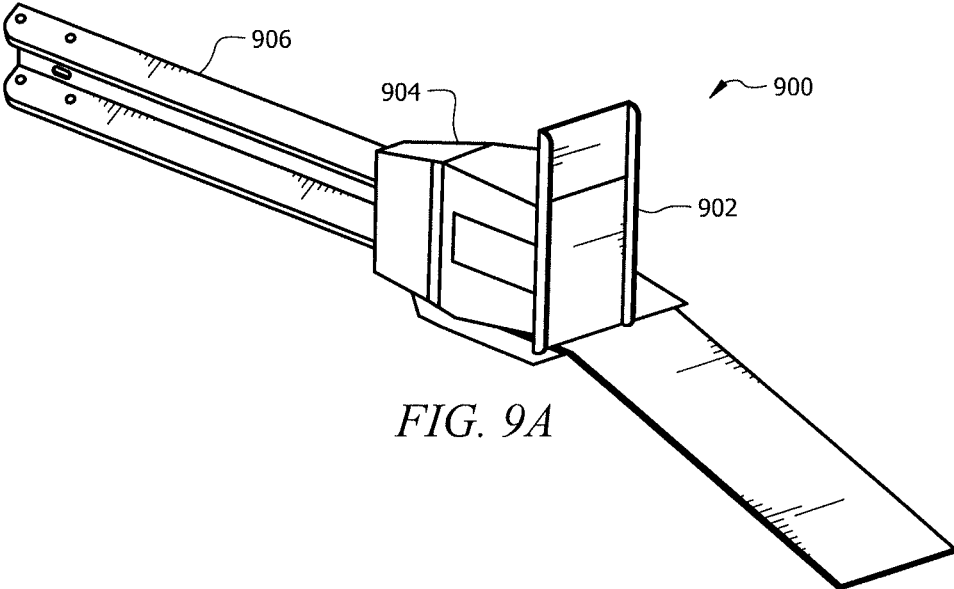

FIG. 9A

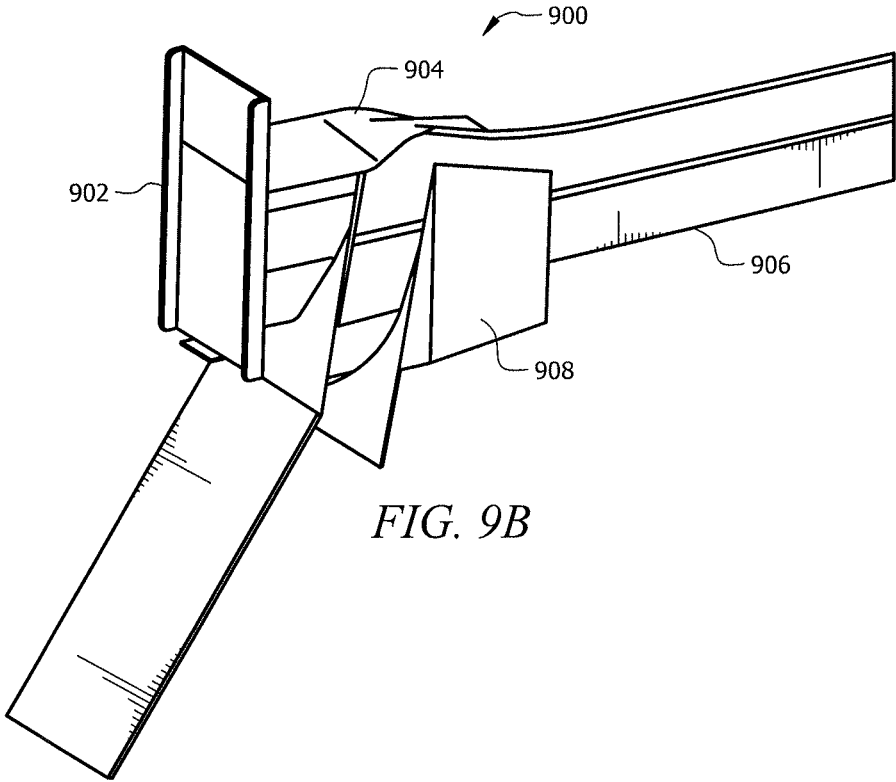

FIG. 9B

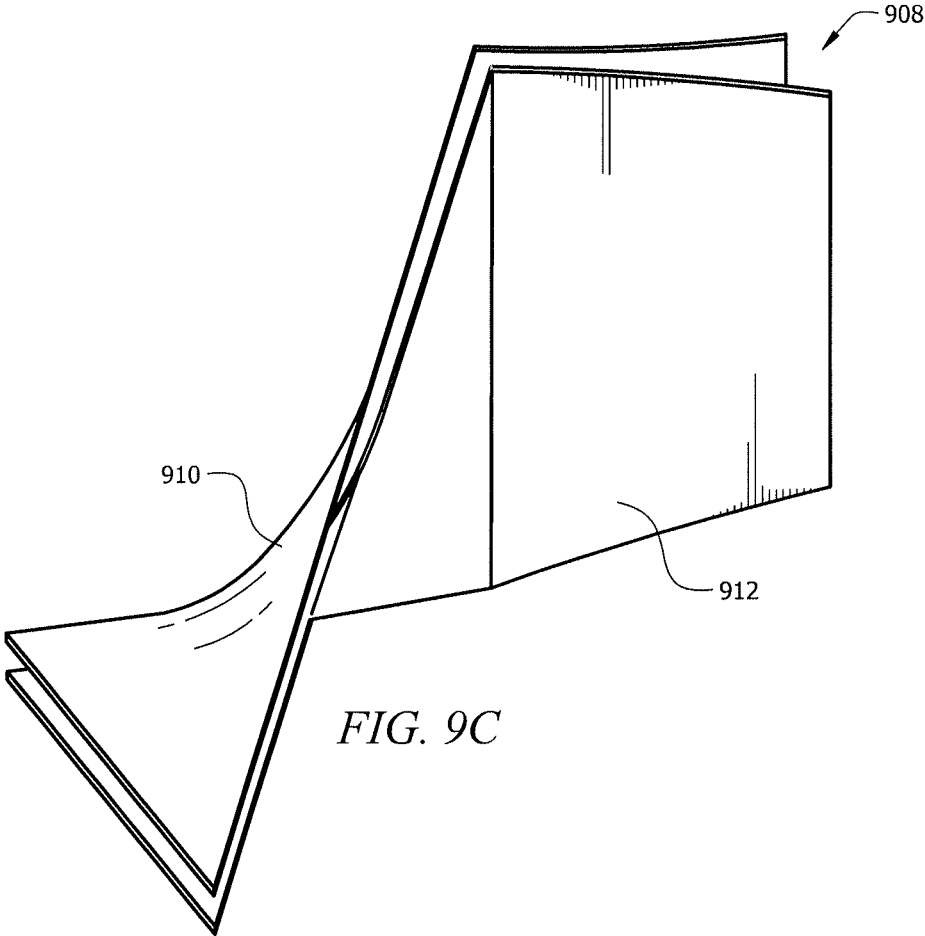

FIG. 9C

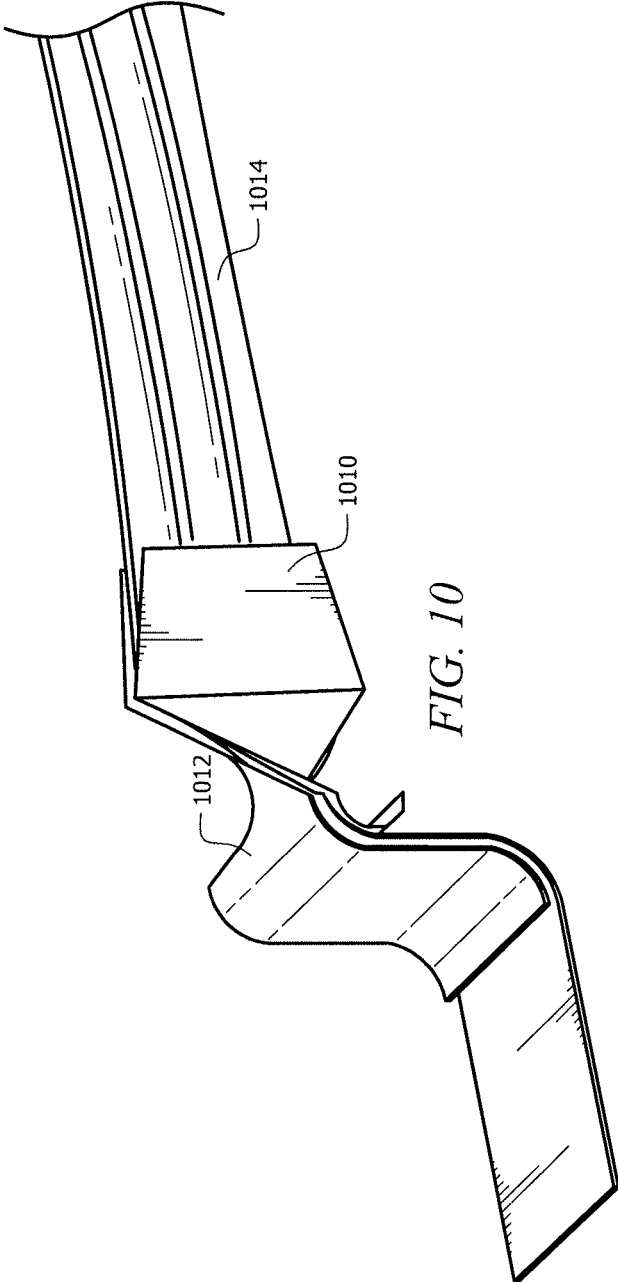
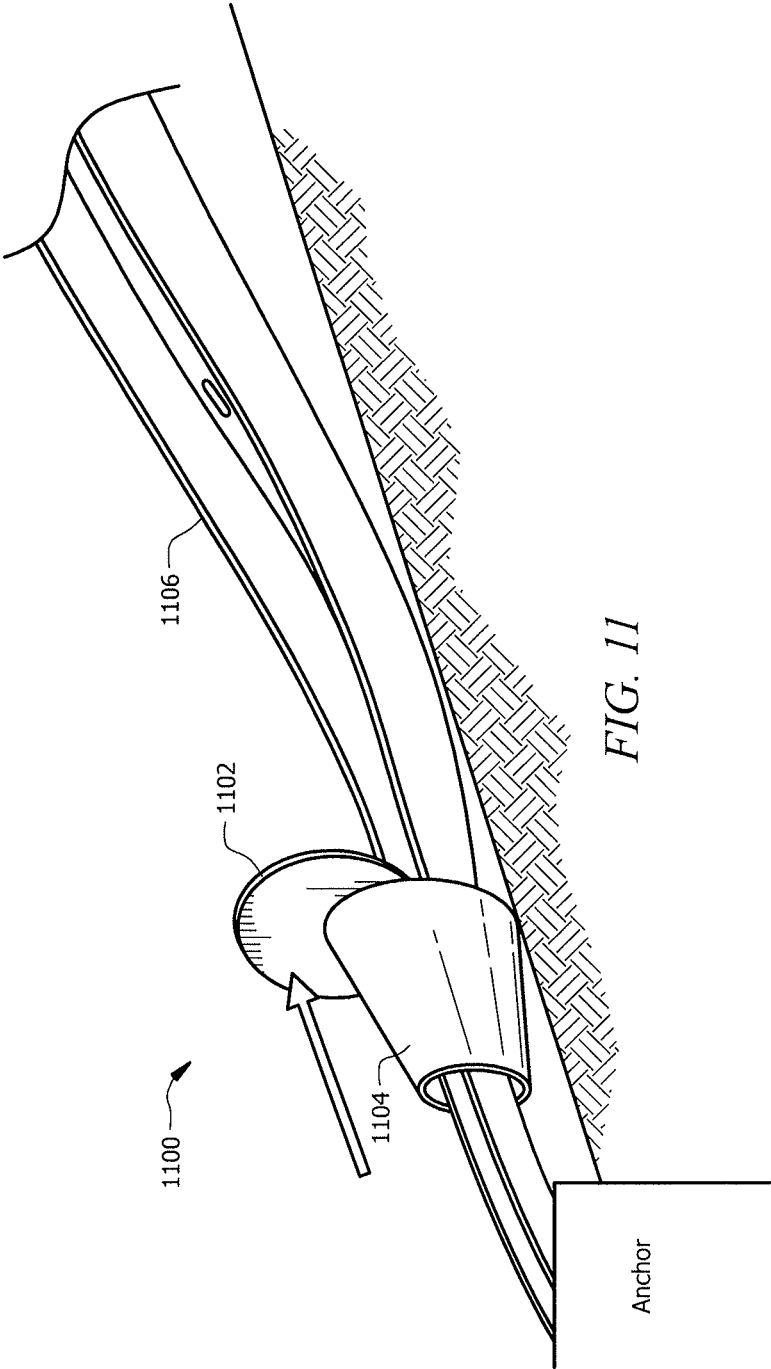

FIG. 10



## TENSION END TREATMENT FOR GUARDRAIL SAFETY SYSTEM

### RELATED APPLICATIONS

This nonprovisional patent application claims priority to U.S. Provisional Patent Application No. 62/195,006, filed Jul. 21, 2015 and entitled "Tension End Treatment For Guardrail Safety System."

### TECHNICAL FIELD

The present invention relates generally to safety end treatment for guardrail beams; and more particularly, to a tensioned end treatment for dissipating impact energy of a car colliding with the end of the guardrail beam.

### BACKGROUND

Along most highways there are hazards that can be a substantial danger to drivers of automobiles if the automobiles leave the highway. To reduce the severity of accidents due to vehicles leaving a highway, guardrails are provided. The guardrails are installed such that the beam elements are in tension to aid in re-directive type impacts. Guardrails must be installed, however, such that the terminal end of the guardrail facing the flow of traffic is not a hazard. Early guardrails had no proper termination at the ends, and it was not uncommon for impacting vehicles to become impaled on the guardrail causing intense deceleration of the vehicle and severe injury to the occupants. In some reported cases, the guardrail penetrated directly, into the occupant compartment of the vehicle fatally injuring the occupants.

Upon recognition of the problem of proper guardrail termination, guardrail designs were developed that used box beams and W-beams that allow tapering of the end of the guardrail into the ground. Such designs eliminate any spearing effect. While these end treatments successfully removed the danger of the vehicle being penetrated in a head-on collision, it was discovered that these end treatments operate in a ramp-like fashion and may induce launching of the vehicle causing it to become airborne for a considerable distance with the possibility of roll over.

In search for better end treatments, improved energy absorbing end treatments for W-beam guardrail elements were developed. For example, an extruder terminal was developed and typically includes a bending structure that squeezes the guardrail into a flat plate and then bends it about a circular arc directed away from the impacting vehicle. Example extruder terminal products include the ET 2000™ and the ET-PLUS™ offered by Trinity Highway Products. Other extruder terminal products include the SKT 350™ and FLEAT 350™ offered by Road Systems, Inc.

Many of these energy absorbing systems use a cable to connect the first w-beam guardrail segment to the first post in the system. The cable provides tension in the guardrail beam element for a redirective hit along the length-of-need portion of the guardrail. A number of cable releasing posts have also been developed for use in these terminals. The cable release posts are intended to release the cable anchor and, thus, release the tension in the system when the post is impacted in either of a forward (end-on) or reverse direction. Such systems are not able to remain in tension during end-on and reverse-direction type impacts.

### SUMMARY OF THE INVENTION

The present invention provides a new and improved tension end treatments for highway guardrails.

According to a particular embodiment, an end treatment for a guardrail safety system includes a terminal portion of a guardrail beam comprising a downstream end and upstream end, a first tension cable coupled to an upstream end of the terminal portion. an extruder configured to receive at least a portion of the guardrail beam and at least a portion of the first tension cable, and a terminal support post installed adjacent the roadway at an upstream end of the terminal portion of the guardrail beam. The extruder includes a narrowing throat providing a channel in which at least a portion of the guardrail beam is disposed. The narrowing throat is configured to flatten the guardrail beam in response to a collision with a vehicle moving the extruder in a downstream direction along the guardrail beam. The terminal support post coupled to an upstream end of the first tension cable.

Technical advantages of particular embodiments of the present invention include a guardrail end treatment that dissipates impact energy for deceleration of the impacting vehicle. Another advantage may be that a tensile and resistive coupling may be provided for connecting an end of the W-beam guardrail element to a terminal support post. The components of the system that provide the tensile connection of the guardrail beam to the terminal support post may enable the guardrail beam to remain secured after an end-on or re-directive impact. Thus, the system may remain in tension during both types of impacts. Still another advantage may be that the tension is released when the system is impacted in the reverse direction near the terminal end, however. The releasing of tension in the guardrail element for reverse direction impacts prevents vehicle instability and excessive deceleration.

Other technical advantages will be readily apparent to one skilled in the art from the following figures, descriptions and claims. Moreover, while specific advantages have been enumerated above, various embodiments may include all, some or none of the enumerated advantages.

### BRIEF DESCRIPTION OF THE DRAWINGS

FIG. 1 illustrates a top view of an exemplary guardrail safety system, according to particular embodiments;

FIGS. 2A, 2B, 2C, 2D, and 2E illustrate various views of a tension end treatment having a single round cable leader, according to particular embodiments;

FIGS. 3A, 3B, 3C, 3D, and 3E illustrate various views of a tension end treatment having a multiple round cable leaders, according to particular embodiments;

FIGS. 4A and 4B illustrate various side views of an exemplary embodiment of an end treatment having a constant slope snout, according to particular embodiments;

FIG. 5 illustrates a particular bracing scheme including to top channel bracing, triangular bracing, and angle bracing, according to a particular embodiment;

FIGS. 6A and 6B illustrate side and top perspective views of the end treatment of FIGS. 4A and 4B implemented using the bracing scheme of FIG. 5, according to a particular embodiment;

FIG. 7 illustrates side perspective view of an exemplary embodiment of an end treatment having a cable guide, according to particular embodiments;

FIG. 8 illustrates a side view of a sliding extruder terminal, according to a particular embodiment;

FIGS. 9A, 9B, and 9C illustrate various views of a sliding extruder terminal, according to another embodiment;

FIG. 10 illustrates a side perspective view of a sliding twister extruder terminal, according to a particular embodiment; and

FIG. 11 illustrates guardrail end treatment having a cone-shaped throat for receiving a terminal portion of a guardrail beam, according to a particular embodiment.

#### DETAILED DESCRIPTION OF EXAMPLE EMBODIMENTS

Existing guardrail end treatments have proven to be unsafe for some collision conditions that happen on the highway, sensitive to installation details, and/or very costly. However, the end treatments described below are safety treatments for the ends of a W-beam or other guardrail that provide a higher level of performance over a wider range of collision conditions and reduces end treatment costs and the number of injuries and deaths associated with guardrail terminal accidents. The described system maintains the tension in the guardrail beam element during both end-on and re-directive type impacts. When the system is impacted in the reverse direction near the terminal end, however, the anchorage system may release to prevent vehicle instability or excessive deceleration.

FIG. 1 illustrates a guardrail safety system 100 that incorporates certain aspects of the present invention. Guardrail system 100 may be installed adjacent a roadway 101, to protect vehicles, drivers and passengers from various obstacles and hazards, and prevent vehicles from leaving the roadway 101 during a traffic accident or other hazardous condition. Guardrail systems that incorporate aspects of the present invention may be used in median strips or shoulders of highways, roadways, or any path that is likely to encounter vehicular traffic.

Guardrail system 100 includes a guardrail beam 102 and support posts 104 that anchor guardrail beam 102 in place along the roadway 101. In a particular embodiment, guardrail beam 102 may include multiple 12-gauge W-beam rail elements of a length on the order of approximately 12.5 feet or 25 feet. The guardrail beam sections may be mounted at a height of on the order of approximately 27 to 31 inches with rail splices positioned mid-span between the support posts 104.

Guardrail beam 102 is attached to support posts 104 with connectors that may include, in particular embodiments, slotted countersunk bolts such as, for example, 16 mm ( $\frac{5}{8}$ -inch) diameter by 38 mm ( $1\frac{1}{2}$ -inch) long flat slot machine screws. Oversized guardrail nuts may be used on the back side of the support post 104. Support posts 104 may be embedded in the ground, a concrete footing, or a metal socket. Support posts 104 may be made of wood, metal, plastic, composite materials, or any combination of these or other suitable materials. It is also recognized that each support post 104 within guardrail system 100 need not necessarily be made of the same material or include the same structural features. Furthermore, the cross-section of support posts 104 may be any engineered shape suitable for releasably supporting guardrail beam 102. Such cross-sectional shapes may include, but are not limited to, square, rectangular, round, elliptical, trapezoidal, solid, hollow, closed, or open.

Guardrail system 100 is intended to keep errant vehicles from leaving roadway 101 during a crash or other hazardous situation. In many instances, guardrail 100 is installed between roadway 101 and a significant hazard to vehicles (e.g., another roadway, a bridge, cliff, etc.). Therefore, guardrail system 100 should be designed to withstand a

significant impact from a direction generally perpendicular to roadway 101, without substantial failure. It is this strength that allows guardrail system 100 to withstand the impact, and still redirect the vehicle so that it is once again traveling generally in the direction of roadway 101.

However, testing and experience has continuously shown that guardrail systems may actually introduce additional hazards to the roadway and surrounding areas. This is particularly true with respect to vehicles that impact the guardrail system adjacent its terminal section, in a direction generally parallel to the roadway. For example, if the guardrail system were rigidly fixed in place during a crash, serious injury and damage may result to the errant vehicle, its driver and passengers. Accordingly, many attempts have been made to minimize this added risk. Such methods generally include the use of terminal portions that are tapered from the ground up to effectively reduce the impact of head on collisions and to create a ramp-like effect that causes vehicles to go airborne during a crash. Other methods include breakaway cable terminals (BCT), vehicle attenuating terminals (VAT), SENTRE end treatments, breakaway end terminals (BET) and the breakaway support posts of U.S. Pat. No. 6,398,192 ("192 patent"). Many such terminals, supports, end treatments and the like are commercially available from various organizations. Examples include the HBA post by Exodyne Technologies and Trinity Industries, and a breakaway support post similar in configuration to that described in the '192 patent.

Referring again to FIG. 1, guardrail system 100 includes one terminal post 106 and seven support posts 104. Collectively, this configuration forms a terminal section 108 of guardrail system 100. As shown, terminal section 108 is employed in a preferred embodiment as an end treatment for a conventional guardrail assembly 100.

Although FIG. 1 is illustrated with dimensions and depicts one exemplary embodiment, it is understood that the dimensions of guardrail system 100 may vary depending on the nature of the roadside hazard being shielded. As illustrated, each terminal section 108 has a length on the order of approximately 35 feet. However, the dimensions of terminal section 108 may vary as needed. Additionally, the length of the length-of-need portion of the system may of any appropriate length required by the conditions of roadway 101.

Terminal section 108 may be installed either parallel to roadway 101 or at an angular departure from roadway 101, as shown best in FIG. 1. Additionally, while the terminal section 108 at one end of the guardrail safety system may be flared or straight flared, the terminal section 108 at the opposite end of the system may not be flared, in certain embodiments. For example, in the embodiment depicted in FIG. 1, an upstream terminal section 108 is flared or straight flared while a downstream terminal section 108 is not flared. Specifically, the upstream terminal sections 108 is flared or straight flared away from roadway 101 in a substantially linear manner while the downstream terminal section 108 remains substantially parallel to the roadway. In other embodiments, both terminal sections 108 may be flared or unflared in a similar manner. Additionally, it is recognized that other configurations may be used for terminal sections 108. For example, one or both of terminal sections 108 may be installed at a parabolic flare away from the roadway. A parabolic flare may be accomplished by increasing the offset of each support post in a generally parabolic progression as the terminal portion proceeds upstream. Where incorporated, positioning of one or more of terminal sections 108 at a flared, straight flared, or angular departure away from roadway 101 may permit the terminal sections 108 to



perform a gating function by facilitating movement of the impacting vehicle to the side of the rail opposite roadway **101** as the vehicle progresses.

In a particular embodiment where terminal section **108** is linearly flared, terminal section **108** may be flared back at an angle of approximately 6 to 7 degrees from the non-terminal portion of the guardrail. Where support posts **104** of terminal section **108** are spaced apart at intervals of approximately 75 inches, the most downstream post **104** of terminal section **108** may be approximately 9 inches offset from a line tangent to the non-terminal portion of the guardrail, in a particular embodiment. Moving toward the upstream end of terminal section **108**, the next four successive support posts **104** may be 19, 29.25, 39, and 48 inches offset from a line tangent to the non-terminal portion of the guardrail, in this embodiment. Terminal post **106**, which may be positioned directly below guardrail beam **102**, may be approximately 47 inches offset from a line tangent to the non-terminal portion of the guardrail, in the described embodiment.

In various embodiments, terminal section **108** includes an end treatment at either or both ends of guardrail system **100**. The purpose of end treatment is to dissipate impact energy of the vehicle without creating a dangerous condition such as causing the vehicle to roll-over or allow the guardrail **102** to spear the vehicle or the occupant compartment of the vehicle. In certain embodiments, the end treatment may be designed to maintain tension in the guardrail **102** during and after impact.

FIGS. 2A, 2B, 2C, 2D, and 2E illustrate various views of a tension end treatment **200** having a single round cable leader through a snout, according to an exemplary embodiment. The tensioned end treatment includes a head **202** that couples to a slotted guardrail beam **204**. Guardrail beam **204** is held in tension by tension cable **206**, which attaches to a downstream end of guardrail beam **204** and exits a snout **207** and tapers to the ground. The coupling between tension cable **206** and guardrail beam **204** is affected by a paddle **208**. The coupling of guardrail beam **204** to tension cable **206** enables guardrail beam **204** to remain secured in tension even after either of an end-on or re-directive impact by a vehicle leaving roadway **101**. However, the components effecting the tensile coupling enables the tension in guardrail beam **204** to be released when the system is impacted in the reverse direction near the terminal end. The releasing of tension in the guardrail element for reverse direction impacts prevents vehicle instability and excessive deceleration.

End treatment **200** includes a front striking plate **209**, coupled to an extruder **210**. Extruder **210** surrounds the upstream portion of guardrail beam **204**. In one embodiment, extruder **210** may be made up of an upper, U-shaped channel member and a lower, U-shaped channel member, which are secured in a spaced relation to one another by strap plates. The vertical distance between the channel members may be an appropriate distance such that guardrail beam **204** is inserted into the channel created by extruder **210**. For example, where guardrail beam **204** comprises a 12-gauge W-beam rail element having a vertical dimension of approximately 12.25 inches, the distance between the top of channel member and the bottom of channel may be approximately 14 inches, in a particular embodiment.

Front striking plate **209** may be secured by welding to extruder **210** of end treatment **200**. Front striking plate **209** may be vertically elongated, in particular embodiments. Thus, front striking plate **209** may extend both above and below extruder **210** to permit front striking plate **209** to be easily engaged by either the high bumper of trucks, SUV's, and other taller vehicles and the low set bumpers of smaller

cars impacting in a frontal manner. Front striking plate **209** is also positioned so as to engage the vehicle frame or rocker panel to reduce vehicle intrusion when the upstream end of end treatment **200** is impacted by a vehicle in a sideways manner.

During an end-on or oblique end-on collision of a vehicle with front striking plate **209**, extruder **210** may be displaced in a downstream direction and downstream portions of guardrail beam element **204** may be forced into the displaced extruder **210**. During such a collision, extruder **210** functions as a guide to guide guardrail beam element **204** into flattening portion **212**, which includes a narrowing throat **213**. Extruder may include guides that prevent shaving of the W-beam guardrail element **204** by ends of extruder **210** as extruder **210** moves along the length of the guardrail beam element **204** during a collision. The guides may accommodate any irregularities or bumps in guardrail beam element **204** to ensure proper feeding of guardrail beam element **204** into flattening portion **212**.

As extruder **210** of end treatment **200** moves along guardrail beam element **204** and downstream portions of guardrail beam element **204** are forced into flattening portion **212** through narrowing throat **213**, guardrail beam element **204** is flattened vertically. Portions of guardrail beam element **204** exiting the upstream end of flattening portion **212** are flattened into what may appear to be two vertically stacked plates, in a particular embodiment. As this flattening process occurs, substantial energy is dissipated slowing the impacting vehicle.

To aid in initial flattening of guardrail beam element **204** and to aid in the coupling of guardrail beam **204** to tension cable **206**, a terminal end of guardrail beam element **204** may be slotted as shown in FIG. 2D. Specifically, the guardrail beam **204** includes a slotted zone at the upstream end of the terminal portion of guardrail beam element **200**. In a particular embodiment, slotted zone **202** comprises a series of slots longitudinally disposed in the guardrail beam element **200**. The use of three slots has proven effective in testing models of guardrails constructed similar to guardrail safety system **100**.

Slotted zone **214** may initiate at a terminal end of guardrail beam **204** and extend a desired distance downstream. The horizontal length of slotted zone **214** may vary depending on the horizontal length of end treatment **200**. It may be desirable for slotted zone **214** to include the portion of guardrail beam **204** that is coupled to paddle **208** and the portion of guardrail beam **204** that traverses through flattening portion **212**. Generally, slotted zone **214** may extend from the terminal, upstream end of guardrail beam element **200** to some distance between the first and second support posts **104**.

The placement of one or more slots in slotted zone **214**, according to a particular embodiment, may be better understood with reference to the cross-section for a typical W-beam guardrail **204** as also shown in FIG. 2E. A valley **216** is positioned between upper and lower peaks **218** and is formed at the intersections of inclined web portions **220**. Edge members **222** laterally out lie each peak **218**. In the depicted embodiment, a single slot is placed at the valley **216**. In another embodiment, multiple slots may be used and the slots may be placed proximate each peak **218** and the valley **216**. Thus, for example, first and second slots may be placed in the first and second peaks **218**, respectively, and a third slot may be placed in valley **216**.

A slot should be of a size sufficient to enhance the ability of the terminal end of guardrail beam **204** to be coupled to paddle **208** and to be flattened. For example, in one particu-

lar embodiment, a slot may be approximately 0.5 inches, as measured vertically. Thus, in a particular embodiment, the slot may have a width on the order of 0.5 inches and extend approximately 81-82 inches. Alternatively, an effective size for the slot has been found to be approximately 0.75 inches, as measured vertically. Thus, the slot may have a width on the order of approximately 0.75 inches and extend approximately 81-82 inches. The provided dimensions are for example purposes only, however. Any number of slots and any size of slot may be used for the one or more slots to enhance the ability of guardrail beam **204** to be coupled to tension cable **206**.

While guardrail beam **204** may include W-beam rail elements, it is generally recognized that the illustrated guardrail beam **204** is merely an example of a beam that may be used in a guardrail system. Guardrail beams **204** or portions of guardrail beams **204** may include conventional W-beam guardrails, thrie beam guardrails, box beams, wire ropes, or other structural members suitable for redirecting an errant vehicle upon impact. It is also recognized that the configuration and dimensions of any of the above-described elements within guardrail system **100** may vary as desired.

Returning to FIGS. **1** and **2**, following the initial end-on impact of a vehicle with end treatment **200** and the initiation of the displacement of end treatment **200** in a downstream direction, the impacting vehicle and end treatment **200** may engage one or more support posts **104**. Where the support posts **104** comprises steel yielding support posts that are modified to release guardrail beam **102** as they are impacted and bent toward the ground. Thus, support posts **104** that are impacted during the collision may be displaced, in certain embodiments, such that they do not pose a hazard to the impacting vehicle. Although guardrail beam **102** may be released from impacted support posts **104**, portions of guardrail beam **102** downstream from the impact may remain in substantially their original position relative to the ground's surface. Further, because guardrail beam **102** remains coupled to tension cable **206** during an end-on or re-directive impact, guardrail beam **102** remains in tension. This extends the range of acceptable performance of guardrail safety system **100**.

The tension in guardrail beam **102** may also be retained in this manner when guardrail system **100** is subject to a redirective impact in the length of need portion of guardrail system **100**. For example, when an impacting vehicle traveling in a direction substantially parallel to the downstream direction of guardrail system **100** leaves the roadway and impacts guardrail system **100**, any support posts **104** impacted by the vehicle may operate to release guardrail beam **102** as they are impacted. Modified support posts **104** may be bent toward the ground such that the support posts **104** are displaced and do not pose a hazard to the impacting vehicle. Because the tension in guardrail beam **102** is maintained, guardrail beam element **102** continues to operate to redirect the vehicle back onto the roadway even after one or more support posts are released from guardrail beam element **102**.

FIGS. **3A**, **3B**, **3C**, **3D**, and **3E** illustrate various views of a tension end treatment **300** having a multiple round cable leaders, according to a particular embodiment. Many features of end treatment **300** may be similar to the features described above with regard to end treatment **200**. Accordingly, common system elements have been labeled using common reference numerals. In contrast to end treatment **200**, however, end treatment **300** depicts the system being held in tension by two cable leaders **302A** and **302B** rather than one. In still another embodiment, a flattened battery

cable leader may be used in place of a round cable. As still a further possible modification, though FIGS. **2A-2E** and FIGS. **3A-3E** depict the one or more tension cables as exiting the end treatment through a snout through the head, other embodiments may include attaching the cable external to the head. Additionally, the one or more tension cables may be attached to the guardrail beam directly and run for some distance longitudinally along the length of the guardrail beam.

FIG. **4** illustrates various side views of an exemplary embodiment of an end treatment **400** having a constant slope snout **402**, according to particular embodiments. The tensioned end treatment includes a head **404** that couples to a slotted guardrail beam **406**. Guardrail beam **406** is held in tension by tension cable **408**, which exits constant slope snout **402** approximate to the ground. The coupling between tension cable **408** and guardrail beam **406** is affected by a paddle **410**. The coupling of guardrail beam **406** to tension cable **408** enables guardrail beam **406** to remain secured in tension even after either of an end-on or re-directive impact by a vehicle leaving roadway **101**. However, the components effecting the tensile coupling enables the tension in guardrail beam **406** to be released when the system is impacted in the reverse direction near the terminal end. The releasing of tension in the guardrail element for reverse direction impacts prevents vehicle instability and excessive deceleration.

Head **404** includes a front striking plate **412** coupled to an extruder **414**. Extruder **414** surrounds the upstream portion of guardrail beam **406**. In one embodiment, extruder **414** may be made up of an upper, U-shaped channel member and a lower, U-shaped channel member, which are secured in a spaced relation to one another by strap plates. The vertical distance between the channel members may be an appropriate distance such that guardrail beam **406** is inserted into the channel created by extruder **414**. For example, where guardrail beam **406** comprises a 12-gauge W-beam rail element having a vertical dimension of approximately 12.25 inches, the distance between the top of channel member and the bottom of channel may be approximately 14 inches, in a particular embodiment.

FIG. **5** illustrates a particular bracing scheme including to top channel bracing, triangular bracing, and angle bracing, in a particular embodiment. As depicted, the bracing scheme includes top channel bracing **502** near the top of extruder **414**. Top channel bracing **502** may be approximately  $\frac{3}{8}$ " thick in a particular embodiment. First triangular bracing **504** is also used proximate the top of extruder **414**. Angle bracing **506** is placed near the bottom of extruder **414** and throat **402**. In a particular embodiment, the angle bracing **506** may include 2"x2"x $\frac{1}{4}$ " bracing. Second triangle bracing **508** is depicted proximate throat **402**. FIGS. **6A** and **6B** illustrate side and top perspective views of an implementation **600** of the end treatment of FIGS. **4A-4B** incorporating the bracing scheme of FIG. **5**, according to a particular embodiment.

Returning to FIG. **4B**, front striking plate **412** may be secured by welding to extruder **414** of end treatment **400**. Front striking plate **412** may be vertically elongated, in particular embodiments. Thus, front striking plate **412** may extend both above and below extruder **414** to permit front striking plate **412** to be easily engaged by either the high bumper of trucks, SUV's, and other taller vehicles and the low set bumpers of smaller cars impacting in a frontal manner. Front striking plate **412** is also positioned so as to engage the vehicle frame or rocker panel to reduce vehicle intrusion when the upstream end of end treatment **400** is impacted by a vehicle in a sideways manner.

During an end-on or oblique end-on collision of a vehicle with front striking plate **412**, extruder **414** may be displaced in a downstream direction and downstream portions of guardrail beam element **416** may be forced into the displaced extruder **414**. Extruder **414** may include guides that prevent shaving of the W-beam guardrail element **406** by ends of extruder **414** as extruder **414** moves along the length of the guardrail beam element **406** during a collision. The guides may accommodate any irregularities or bumps in guardrail beam element **406** to ensure proper feeding of guardrail beam element **406** into constant slope snout **402**.

As extruder **414** of end treatment **400** moves along guardrail beam element **406** and downstream portions of guardrail beam element **406** are forced into constant slope snout **402**, guardrail beam element **406** is flattened vertically. Portions of guardrail beam element **406** exiting the upstream end of constant slope snout **402** are flattened into what may appear to be two vertically stacked plates. As this flattening process occurs, substantial energy is dissipated slowing the impacting vehicle.

To aid in initial flattening of guardrail beam element **406** and to aid in the coupling of guardrail beam **406** to tension cable **408**, a terminal end of guardrail beam element **406** may be slotted in a manner similar to that described above with regard to FIG. 2D. Specifically, the guardrail beam **406** includes a slotted zone at the upstream end of the terminal portion of guardrail beam element **406**. In a particular embodiment, slotted zone **416** comprises a series of slots longitudinally disposed in the guardrail beam element **406**. The use of three slots has proven effective in testing models of guardrails constructed similar to guardrail safety system **100**. Thus, in the particular depicted embodiment, slotted zone **416** includes three slots **418A-C**. A first slot **418A** that extends a first distance from the upstream end of guardrail beam **406**. For example, first slot **418A** is shown extending approximately sixty inches from the upstream end of guardrail beam **406**. A second slot **418B** is shown extending approximately 52.5 inches from the upstream end of guardrail beam **406**, and a third slot **418C** is shown extending approximately 45 inches from the upstream end of guardrail beam **406**. The placement of one or more slots in slotted zone **416**, according to a particular embodiment, may be similar to that described above with regard to FIG. 2D.

Slotted zone **416** may initiate at a terminal end of guardrail beam **406** and extend a desired distance downstream. The horizontal length of slotted zone **416** may vary depending on the horizontal length of end treatment **400**. It may be desirable for slotted zone **416** to include the portion of guardrail beam **406** that is coupled to paddle **410** and the portion of guardrail beam **406** that traverses through constant slope snout **402**. Generally, slotted zone **416** may extend from the terminal, upstream end of guardrail beam element **406** to some distance between the first support post **420** and a second support post (not depicted).

While guardrail beam **406** may include W-beam rail elements, it is generally recognized that the illustrated guardrail beam **406** is merely an example of a beam that may be used in a guardrail system. Guardrail beams **406** or portions of guardrail beams **406** may include conventional W-beam guardrails, thrie beam guardrails, box beams, wire ropes, or other structural members suitable for redirecting an errant vehicle upon impact. It is also recognized that the configuration and dimensions of any of the above-described elements within guardrail system **100** may vary as desired.

As depicted, guardbeam rail **406** feeds into a downstream end of constant slope snout **402**. Conversely, tension cable **408** feeds through an upstream end of constant slope snout

**402** at a downstream end of end treatment **400**. Further, constant slope snout **402** extends from the upstream end and slopes toward the ground. Specifically, constant slope snout **402** is configured to transition guardrail beam **406** from a height above the ground level that is appropriate for redirecting an impacting vehicle (31 inches, in a particular embodiment) to ground level.

FIG. 7 illustrates an exemplary embodiment of an end treatment **700** having a cable guide **702**, according to particular embodiments. Specifically, cable guide **702** may comprise a retrofit component that may be added to existing and in use end terminal systems. Many features of end treatment **700** may be similar to the features described above with regard to end treatment **200**. Accordingly, common system elements have been labeled using common reference numerals.

According to certain embodiments, end treatment **700** includes a terminal portion of a guardrail beam **102** comprising a downstream end and upstream end. At least a portion of the upstream end feeds into extruder **210**. In certain embodiments, a tension cable **708** is coupled to a terminal support post using any suitable technique described above. Tension cable **708** feeds through cable outlet **706** at an upstream end of extruder **210**. In a particular embodiment, for example, tension cable **708** may feed through cable outlet **706** of striking plate **208**. Tension cable **708** then traverses through cable guide **702** from an upstream end to a downstream end of extruder **210**.

In the illustrated embodiment, cable guide **702** comprises a tube through which the tension cable **708** is threaded. The cable guide **702** may be configured to transition the tension cable from a first height above ground level to a second height that is lower than the first. Cable guide may be uniformly sloped from the first height to the second height. At a downstream end of extruder, tension cable **708** may be threaded through cable **704** to exit the extruder **210**.

In a particular embodiment, cable guide **702** may include two sections through which tension cable **708** is disposed. The first portion is a downstream portion that is substantially horizontal and runs substantially parallel to extruder **210** and guardrail beam **102**. A second portion extends from the upstream end of the first portion and slopes toward the ground. In a particular embodiment, the second portion may be uniformly sloped from the first height to the second height. Specifically, the second portion is configured to transition tension cable **708** from a first height above the ground level that is appropriate for redirecting an impacting vehicle (31 inches, in a particular embodiment) to an outlet **706** of extruder **210** that is lower than the first height.

An upstream end of tension cable **708** is then anchored to a terminal support post, similar to the terminal support post **106** described with regard to FIG. 1. To maintain the system in tension, a downstream end of the tension cable may be coupled to a terminal support post and an upstream end of the tension cable may be coupled to a support post positioned downstream from the extruder **210**.

FIG. 8 illustrates an exemplary sliding extruder terminal system **800**, according to a particular embodiment. As described above, certain prior terminal systems may share a common limitation, which is the inability to sustain tension in the rail system once the anchor cable is disengaged. The only system known to carry tension in the turned-down guardrail system is not approved for installation on national highway systems due to the system's role in destabilizing a vehicle (i.e., rollover).

As illustrated in FIG. 8, however, sliding extruder terminal system **800** includes a modified extruder terminal throat

**802**, which accepts a guardrail beam and twists the guardrail beam from a substantially vertical position to a substantially horizontal position. According to particular embodiments, extruder terminal system **800** includes throat **802** having an inlet at a downstream end that is wider than the outlet at the upstream end of the throat **802**. In operation, throat **802** converts the impacting vehicle kinetic energy into internal energy by flattening the rail. In a particular embodiment, throat **802** may flatten a W-beam guardrail beam into a flat plate. Thus, extruder terminal system **800** includes a guardrail beam having a substantially horizontal portion **804**, a pre-twisted portion **806**, and a flattened end portion **808**. The upstream end of flattened end portion **804** may be anchored to a terminal anchor post at ground level or in any other suitable anchoring system.

The twister may help maintain the flat portion of the rail on a horizontal traversable profile. In certain embodiments, sliding ET **800** may consist of two main components: the slider top **810** and slider bottom **812**. The slider top **810** and slider bottom **812** may be joined during construction using bolting and/or clamping fastening techniques.

FIGS. 9A-C illustrate various views of a sliding extruder terminal **900**, according to another embodiment. Specifically, FIG. 9A is an oblique view of sliding extruder terminal system **900**, according to a particular embodiment. Sliding extruder terminal system **900** includes front portion **902** and back portion **904**, which may be joined at the time of installation through some connection details such as bolting. In particular embodiments, an undeformed portion of guardrail beam **906** and sliding extruder terminal **900** are at the same height as that of a standard w-beam when installed adjacent a roadway.

In a particular embodiment, sliding extruder terminal **900**'s includes a throat twister **908**, which takes the standard w-beam shape and flattens it as the guardrail beam **906** moves through the throat twister **908**. Throat twister **908** also simultaneously twists guardrail beam **906** toward the ground. The profile of the w-beam **906** before, thru and after engaging sliding extruder terminal **900** is shown in FIG. 9B. FIG. 9C illustrates the components of throat twister **908** in more detail. As depicted, in a particular embodiment, throat twister **908** includes a first plate **910** and a second plate **912**, which are disposed proximate one another such that when guardrail beam **906** moves between first and second plates **910** and **912** guardrail beam **906** is flattened into a substantially flat plate.

FIG. 10 illustrates a sliding twister extruder terminal **1000**, according to a particular embodiment. Similar to the extruder terminal system of FIG. 9, sliding twister extruder terminal system **1000** includes a first plate **1010** and a second plate **1012**, which are positioned proximate one another to result in the flattening of guard rail beam **906** into a substantially flat plate. as extruder terminal is moved along the guard rail beam in a collision. More specifically, sliding twister extruder terminal **1000** receives the standard w-beam guardrail **1014** at a downstream end and flattens guardrail beam **1014** as guardrail beam **1014** moves through the throat including the first and second plates **1010** and **1012**. Sliding twister extruder terminal **1000** also twists guardrail beam **1014** toward the ground. In particular embodiments, sliding twister extruder terminal **1000**, squeezes guardrail beam **1014** into a substantially flat plate while simultaneously twisting guardrail beam **1014** by 90 degrees. Extruder terminal **1000** then turns the guardrail beam around 90 degrees again to run parallel to the ground. Tension is accomplished

in guardrail beam **1014** by fixing the upstream end of the guardrail beam **1014** to the ground.

FIG. 11 illustrates guardrail end treatment **1100** having a striking plate **1102** and a cone-shaped throat **1104** for receiving a terminal portion of a guardrail beam **1106**, according to a particular embodiment. The guardrail end treatment **1100** may suitable for turned down guardrail end treatment. In a particular embodiment, for example, guardrail end treatment **1100** may be appropriate for incorporation into the terminal system known as the Texas Twist.

In a particular embodiment, the terminal portion of a guardrail beam **1106** includes a downstream end and upstream end. The cone-shaped throat **1104** may be configured to receive at least a portion of the guardrail beam **1106**. As depicted, cone-shaped throat **1104** may form a narrowing channel through which at least a portion of the guardrail beam **1106** is threaded. In a particular embodiment, a diameter of a downstream end of the cone-shaped throat **1104** may be greater than a diameter of an upstream end of the cone-shaped throat **1104**. As a result, cone-shaped throat **1104** may operate to flatten guardrail beam **1106** in response to a collision with a vehicle, such as when the vehicle results in the displacement of cone-shaped throat **1104** in a downstream direction along the terminal portion of the guardrail beam **1106**.

In a particular embodiment, the guardrail beam **1106** comprises a w-beam member such as that described above. Additionally, guardrail beam **1106** may be configured with at least one slotted zone formed in an upstream end of the w-beam member **1106**. Cone-shaped throat **1104** may be configured to flatten the slotted w-beam member into a plurality of stacked plates.

In certain embodiments, the guardrail end treatment **1100** may be located where the guardrail transitions from vertical at a support post such as support post **104** to horizontal at the grade. In a particular embodiment, the striking plate **1102** comprises a rounded vertical plate that serves to catch the errant vehicle and push/slide a cone-shaped throat **1104** downstream along the guardrail beam **1106**. In certain example implementations, the depicted embodiment may be used as a retrofit to an existing guardrail end treatment system.

Technical advantages of particular embodiments of the present invention include a guardrail end treatment that dissipates impact energy for deceleration of the impacting vehicle. Another advantage may be that a tensile and resistive coupling may be provided for connecting an end of the W-beam guardrail element to a terminal support post. The components of the system that provide the tensile connection of the guardrail beam to the terminal support post may enable the guardrail beam to remain secured after an end-on or re-directive impact. Thus, the system may remain in tension during both types of impacts. Still another advantage may be that the tension is released when the system is impacted in the reverse direction near the terminal end, however. The releasing of tension in the guardrail element for reverse direction impacts prevents vehicle instability and excessive deceleration.

Although the present invention has been described by several embodiments, various changes and modifications may be suggested to one skilled in the art. It is intended that the present invention encompass such changes and modifications as fall within the scope of the present appended claims. For example, the features described above may be used independently and/or in combination with each other or other design modifications.

What is claimed is:

13

- 1. An end treatment for a guardrail safety system comprising:
  - a terminal portion of a guardrail beam comprising a downstream end and an upstream end;
  - a first tension cable having a downstream end and an upstream end, the upstream end being coupled to a terminal support post installed adjacent the roadway at an upstream end of the end treatment, the downstream end of the first tension cable being coupled to a support post;
  - an extruder configured to receive at least a portion of the terminal portion of the guardrail, the extruder configured to be displaced in a downstream direction in response to a collision with a vehicle moving in the downstream direction;
  - a striking plate at an upstream end of the extruder, the striking plate extending above and below the extruder, the striking plate being configured with an outlet through which the first tension cable passes, the outlet being at a location above ground level;
  - a cable guide coupled to the extruder, the cable guide comprising a tube through which the first tension cable passes, the cable guide configured to transition the tension cable from a first height above the ground level to a second height that is lower than the first height and proximate the location of the outlet in the striking plate at the location above the ground level.
- 2. The end treatment of claim 1, wherein the cable guide comprises:
  - a first portion that is horizontal and runs parallel to a length of the extruder; and
  - a second portion that extends from an upstream end of the first portion and slopes toward the ground, wherein the second portion is configured to transition the tension cable from the first height to the second height that is lower than the first height.
- 3. The end treatment of claim 1, wherein at least a portion of the cable guide is uniformly sloped from the first height to the second height.
- 4. The end treatment of claim 1, wherein the extruder comprises a cable eye at a downstream end of the extruder, the tension cable passing through the cable eye.
- 5. An end treatment for a guardrail safety system comprising:
  - a terminal portion of a guardrail beam comprising a downstream end and an upstream end;
  - a first tension cable coupled to the upstream end of the terminal portion of the guardrail beam;

14

- a second tension cable having a downstream end and an upstream end, the downstream end of the first tension cable being coupled to a support post;
- an extruder configured to receive at least a portion of the guardrail beam and at least a portion of the first tension cable, the extruder comprising a narrowing throat providing a channel in which the at least a portion of the guardrail beam is disposed, wherein the narrowing throat is configured to flatten the guardrail beam in response to a collision with a vehicle moving the extruder in a downstream direction along the guardrail beam;
- a striking plate at an upstream end of the extruder, the striking plate extending above and below the extruder, the striking plate being configured with an outlet through which the first tension cable passes, the outlet being at a location above ground level;
- a cable guide coupled to the extruder, the cable guide comprising a tube through which the first tension cable passes, the cable guide configured to transition the tension cable from a first height above the ground level to a second height that is lower than the first height and proximate the location of the outlet in the striking plate at the location above the ground level; and
- a terminal support post installed adjacent the roadway at the upstream end of the end treatment, the terminal support post being coupled to an upstream end of the first tension cable and the upstream end of the third tension cable proximate ground level, and wherein the guardrail beam comprises a w-beam member, wherein the guardrail beam includes a plurality of slotted zones formed in an upstream end of the w-beam member, wherein the first tension cable is coupled to the terminal portion of the guardrail beam by a first paddle configured to maintain the tension cable in tension during an end-on or re-directive impact by a vehicle leaving a roadway, wherein the second tension cable is coupled to the terminal portion of the guardrail beam by a second paddle configured to maintain the tension cable in tension during the end-on or re-directive impact by the vehicle leaving the roadway, and wherein the narrowing throat is configured to flatten the w-beam member into a plurality of stacked plates.

\* \* \* \* \*