

Bhopal gas Tragedy: A safety case study

CHEN 455: Chemical Process Safety - Fall 2009

Texas A&M University at Qatar

17/11/2009

To: Dr. Simon Waldram

Done By:

Omar Basha

Jawaher Alajmy

Tahira Newaz

Table of contents:

1. Introduction	5
2. Background.....	6
2.1 Union Carbide India Limited	6
2.2 Union carbide MIC plant: layout and process chemistry	6
2.3 MIC Toxicity.....	7
2.4 Process chemistry of carbamate pesticides.....	8
2.5 Available safety systems	9
2.6 Previous warnings and accidents at Bhopal	10
3. The leak	10
3.1 The leak timeline	10
3.2 Causes of the release	12
3.3 Leak development and gas dispersion	14
3.4 Emergency planning and response	16
3.5 Consequences	16
4. Bhopal: Investigations and lessons	17
4.1 Introduction:.....	17
4.2 They had it coming: Union Carbide- A history of negligence	17
4.2.1 Safety failures at Union Carbide’s plant: FACTS.....	17
4.2.2 Previous Incidents at the Union Carbide plant	19
4.3 Previous Investigations and results:.....	22
4.3.1 The Indian Government Version: Water Washing Theory	22
4.3.2 The Union Carbide Version: Sabotage theory	24
4.3.3 Conclusion.....	28
5. Lessons and Observations from Bhopal	29
6. Conclusion	32
7. References	33

List of Tables and Figures:

1. **Table 1:** Major industrial accidents²
2. **Figure 1:** Map of Bhopal showing ULIC location⁴
3. **Figure 2:** Health and Regulatory guidelines for MIC⁵
4. **Figure 3:** MIC Storage System²
5. **Figure 4:** The MIC Plant¹⁰
6. **Figure 5:** affected areas of Bhopal City (shaded region)¹⁶
7. **Figure 6:** Flow diagram of the Tank 610 system
8. **Figure 7:** An accident model for Bhopal showing critical events and recommendations

Executive Summary

This report provides an overview of the Bhopal Gas disaster which occurred at the Union Carbide pesticide production plant in India in 1984. A large amount of Methyl Isocyanate (MIC) was released from tank 610 within the facility, a failure of safety and alarm systems allowed the gas cloud spread and kill thousands of people resulting in one of history's worst chemical accidents.

This paper will first discuss the plants setting and establishment before providing a brief background on the layout of the plant and the chemical process underwent. It will then discuss MIC and pesticide toxicity and the importance of safety systems within the plant and how Union Carbide's plant failed to meet such standards.

The second major section of the report will describe how the leak propagated and dispersed throughout the city, what emergency procedures were taken to counteract it, and its aftermath and effects both on the local people and the people involved with Union Carbide.

The report will then discuss previous investigations about the tragedy and will focus primarily on the two biggest investigations conducted by both the Indian Government and Union Carbide respectively, investigating the proposed scenarios and their feasibility and whether there are other probable scenarios.

The last major part of the report will discuss how such an incident revolutionized chemical process safety and the various conclusions that could be drawn from this situation to prevent similar tragedies from occurring in the future.

1. Introduction

On December 3 1984, in the city of Bhopal, a highly toxic cloud of methyl isocyanate(MIC) vapor burst from the Union Carbide pesticide plant. Of the 800,000 people living in Bhopal at the time, 2,000 died immediately, and as many as 300,000 were injured¹. MIC was a major component for the production of the pesticide Sevin by the Union Carbide factory at Bhopal. This incident we now refer to as the Bhopal Gas Tragedy is one of the worst commercial industrial disasters in history. It is described as a low probability-high consequence accident. The tumultuous outcome of the accident was a cumulative effect of the following seven reasons².

1. Large release of chemical from the plant.
2. Release of colorless, odorless MIC, which is highly toxic.
3. Heavily populated areas adjacent to the plant.
4. Calm weather conditions, bringing the vapor cloud down
5. Leak occurs at night when people are sleeping.
6. Failure or late warnings
7. Unqualified and unaware people working at the plant

Due to the magnitude of the accident, the Bhopal disaster has been the focus of media and an example of lessons to be learnt for industrial safety. This incident which has also been called “Hiroshima of the Chemical Industry” one of the worst commercial industrial disasters in history³. Table 1 below provides a list of the major industrial accidents that occurred in a period of 65 years (1921-1986) with their fatalities. After the incidence, over the next few years, numerous studies were conducted, many theories were explored, and the involved parties accused each other. This report will explore the various causes offered for the tragedy and the strategies that Union Carbide Corporation used through the course of the crisis.

Table 1: Major industrial accidents²

Year	Accident	Site	Fatalities (Number)
1921	Explosion in chemical plant	Oppau, Germany	561
1942	Coal dust explosion	Honkeiko Colliery, China	1527
1947	Fertilizer ship explosion	Texas City, USA	562
1956	Dynamite truck explosion	Cali, Colombia	1100
1974	Explosion in chemical plant	Flixborough, UK	28
1975	Mine flooding	Chasnala, India	431
1976	Chemical leak	Seveso, Italy	(?)
1979	Biological warfare plant accident	Novosibirsk, USSR	300
1984	Natural gas explosion	Mexico City, Mexico	452
1984	Poisonous gas leak	Bhopal, India	2500
1986	Nuclear power plant accident	Chernobyl, USSR	Exact number not known

2. Background

After the independence of India, in 1947, the first major problem faced by the nation was to cope with food shortage. The government decided to join the Green Revolution initiative started by the United States, aimed at tremendously increasing the production of food grains in underdeveloped countries⁴. However, the change from traditional to capitalist farming required many inputs including pesticides. Bhopal, the capital of Madhya Pradesh, an agricultural city had few industries.

2.1 Union Carbide India Limited (UCIL)

The UCIL was a 50.9% subsidiary of the Union Carbide Corporation, the third largest chemical manufacturing corporation functioning at the time of the accident⁴. The UCIL was founded in Bhopal and was fully operated by Indian labor. This plant was a packaged transfer where UCC arranged for starting the project, attaining process licenses and all other technicalities. The Chief Minister of Madhya Pradesh, Mr. Arjun Singh was responsible for moving the agricultural office of Union Carbide India Limited (UCIL) from Bombay to Bhopal in 1968 and actual production began in 1979⁴. The manufacture of the pesticide Sevin was undertaken by importing the Sevin Technical Concentrate from the United States and the processing was done at Bhopal. The profit from manufacturing Sevin from UCIL was low due to competition from other pesticide manufacturers nearby. Despite initial expectations of producing 2000 tons of carbaryl, the plant was actually producing much less due to the decreasing demand. However, within four years of the operation of the plant, 30 metric tons of MIC gas leaked out UCIL plant². This accident proved to be disastrous for Union Carbide, since the loss of thousands of people due to improper safety regulations Union Carbide became a subsidiary of Dow Chemical to avoid bankruptcy.

2.2 Union Carbide MIC plant: Layout and Process Chemistry

It has been speculated that the high number of casualties occurred due to the location of residents in close proximity of the ULIC plant. The dense cloud formed from the leak settled over these shanty towns around the plant, most of which were inhabited by factory workers⁴. It is estimated that about 5000 people died within two days of the accident³. The Bhopal UCIL plant was located just on the outskirts of the city, a mere 3km away from two major hospitals and just about a 1 km away from the railway station, despite regulations requiring chemical plants producing pesticides and insecticides to be located within an industrial zone of 25 km away from the nearest city². The plant's location has been questioned by the commissioner and director of Bhopal and many futile attempts have been done to try and relocate it due to the numerous health risks involved. Figure 1 below shows the location of the ULIC plant relative to the city at the time of the leak.

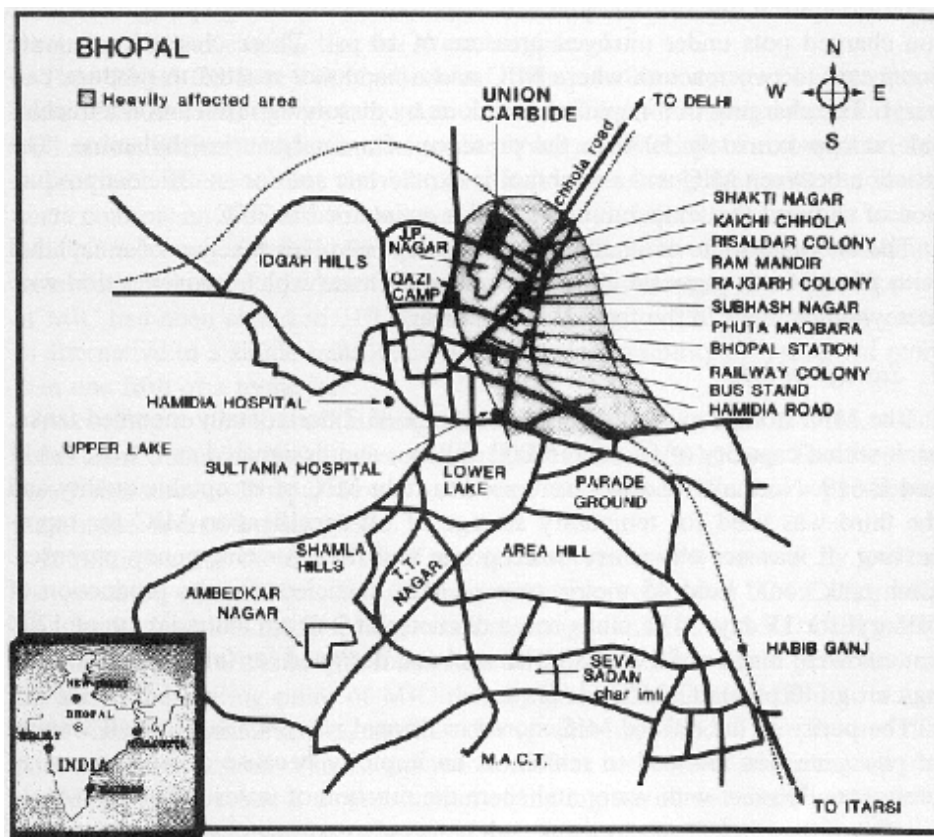

Figure 1: Map of Bhopal showing ULIC location⁴

2.3 MIC Toxicity

To understand the toxicity of MIC, the chemistry of isocyanates, which accounted for the high fatality, will be discussed. Isocyanates consists $R-N=C=O$ and thus belong to the heterocumelene group. Methyl isocyanate is highly reactive due to the cumulative action from the presence of adjacent double bonds. MIC is more adverse to health when inhaled than ingested, which explains the catastrophic effect caused on that fateful day. Having a boiling point of 39.1°C , MIC vaporizes at room temperature and exists as an odorless, colorless gas⁴. The effects of MIC can be detected by contact, resulting in watering of the eyes and irritation of the throat. According to the Occupational Safety and Health Administration (OSHA), the exposure limit for MIC has been set s 0.02ppm during an 8 hour period⁴, this is an indication of how serious a risk MIC poses. However, at the time of the Bhopal disaster, only one report stating the toxicity of MIC was present in literature. An appalling price had to be paid before the fatal effects of MIC were known.

The health regulations and guidelines by NIOSH and OSHA are shown in figure 2 below.

Health & Regulatory Guidelines

- **EPA Regulations:**
 - Reportable Quantity: 10 Lbs
- **NFPA 704 Rating:**
 - Health Hazard Rating: 4
 - Fire Hazard Rating: 3
 - Reactivity Hazard Rating: 2
 - Other Hazards: H2O
- **NIOSH Guidelines:**
 - TWA: 0.02 ppm
 - IDLH: 3 ppm
 - Conversion: 1 PPM = 2.34 mg/m³@ 25°C & 1ATM
- **OSHA Regulations:**
 - TWA: 0.02 ppm
 - TWA Vacated: 0.02 ppm
- **Health Risks:** Highly Toxic
- **Notes:** Usually contains inhibitors to prevent polymerization.

Figure 2: Health and Regulatory guidelines for MIC⁵

2.4 Process Chemistry of Carbamate Pesticides

The following scenario was used by ULIC to produce carbamate pesticides⁴:

- I. $2C + O_2 \rightarrow 2CO$
- II. $CO + Cl_2 \rightarrow COCl_2$
- III. $PH_3 + CH_3NH_2 \rightarrow CH_3NHC OCL + HCL$
- IV. $CH_3NHC OCL \rightarrow MIC(CH_3NCO) + HCL$
- V. $MIC + \alpha\text{-naphthol} + CCl_4 \rightarrow 1\text{-naphthyl methylcarbamate}$

MIC reacts with water exothermically, generating heat above its boiling point and thus turns from liquid to vapor. Hence the existence of even a small amount of water can be sufficient to produce enough heat to cause ruptures and leaks.

2.5 Available safety systems

Investigations after the incident showed that the Bhopal plant was loosely maintained, with serious lapses in the day to day operations of the plant. Over time, more unqualified staff were hired and the mandatory six months training was abandoned. At the time of the tragedy the staff maintaining the plant was reduced

to half with only six operators, one supervisor and no full time superintendent². The plant could not detect leaks automatically and many times a leak was identified by its symptoms of throat irritation and watering of eyes among the plant workers. The emergency alarms installed to warn of any leaks were nonoperational and no effective public evacuation scheme was reserved⁶.

The primary existing safety systems at the Bhopal MIC plant were the scrubber, water spraying system and flare, all of which were nonfunctional during the time of the leak. The scrubber was capable of neutralizing MIC entering at 90 kg/hr at 35°C at 15 psi at its peak performance⁴. The MIC that escaped that night was 200 times higher in pressure and about 6 to 10 times higher in temperature, which eventually led to the scrubber's failure⁴. Likewise, the flare was capable of burning only miscible amounts of MIC and the water curtain system was capable of spraying water only to a height of 15m while the MIC leaked at heights of about 50 m⁴. Figure 3 below is a schematic showing the vent gas scrubber, the flare tower and the MIC storage tank.

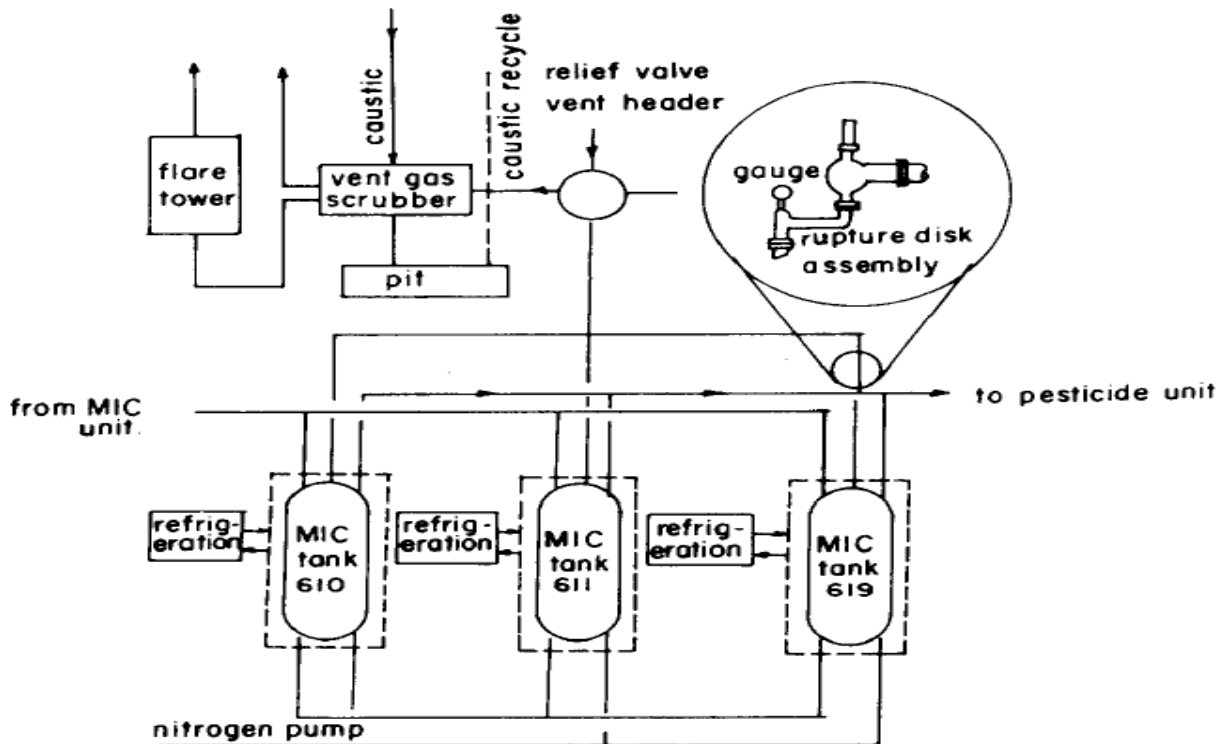

Figure 3: MIC Storage System²

2.6 Previous Warnings and Accidents in Union Carbide Industry:

The absence of proper safety systems and the general staff negligence at ULIC contributed greatly to the disastrous effects of the Bhopal gas leak. Many previous warnings and similar incidents from the plant were ignored by the ULIC management. As many as six accidents had occurred at the plant before the major catastrophe. Previously, Safety auditors from Union Carbide had reported that plant

operations were unsafe and required the ULIC plant to have a disaster and evacuation emergency plan². Moreover, the Indian Labor Department had previously ordered for changes at the plant, none of which were taken into consideration to improve plant safety. Many journalists concluded that ULIC's inattention to requests for restructuring the plant were ignored due to the dwindling demand for its pesticide- Sevin in the 1980s as poor Indian farmers preferred buying the same pesticides from smaller operating plants at half the price⁶.

Basically, the Bhopal disaster was a result of many legal, technological, organizational, and human errors all which contributed to cause this industrial disaster.⁷ Before the disaster, many prior warnings and accidents related to methyl isocyanate had occurred in the industry, but none received the massive media attention Bhopal did.

One of these accidents took place in 1981 when a worker was exposed to phosgene gas. As known, phosgene gas is a severe eye and respiratory irritant. A concentration of 3 ppm is enough to cause an immediate throat irritation. As the concentration increases, immediate eye irritation may occur and results in death.⁸ When the worker got splashed with the phosgene gas, he panicked, immediately removed his safety mask, inhaled a large amount of phosgene gas and died 72 hours later. In 1982, another phosgene leak occurred and 24 workers were exposed to the gas, because protective masks was not enforced, the exposure resulted in severe injuries to the workers.⁹ After this incident, the workers futilely demanded safer working conditions. Another incident took place in 1982 when an engineer also came into contact with methyl isocyanate, resulting in burns to 30% of his body.¹⁰

Moreover, In October 1982, there was a leak of some substances including: MIC, methylcarbaryl chloride, chloroform, and hydrochloric acid. When one of the valves in the MIC pipeline was opened, the joint of the pipeline connecting it to the other pipelines suddenly broke. The operator suffered from serious chemical burns in an attempt to stop the leakage.¹⁰ All these incidents were ignored by the plant management.

3. The Leak

3.1 Leak Timeline

The timeline below gives the most popular account of the events that took place on December 2nd and 3rd at the Bhopal Plant.

December 2, 1984:

- 8-9 pm: The MIC plant supervisor was ordered to wash out several pipes running from the phosgene system to the scrubber through the MIC storage tanks. The maintenance department is responsible for inserting the slip bind (a solid disk) into the pipe above the water washing inlet. However, the MIC unit workers were not aware that the installation of these slip blinds is a required safety procedure, and the slip bind was not installed. The temperature of MIC in tanks was between 15 and 20 °C.¹¹
- 9:30 pm: The water washing begins. One of the bleeder valves (overflow device) was blocked so water did not come out as it was supposed to. It was collected in the pipes. The plant supervisor ordered that the washing continue until it had risen past a leaking isolation valve in the lines being washed and got into the relief valve pipe 20 feet above ground.¹¹
- 11 pm: The operator in the control room noticed pressure gauge connected to Tank E610 had risen from 2 psi to 10 psi. The rise in pressure didn't arouse any concerns to the operator since 10 psi is within the normal 2-25 psi range. However, the control room lacked monitoring the temperature of the tank.¹¹
- 11.30 pm: The unit workers in the area noticed MIC's smell and saw an MIC leak near the scrubber. They also found MIC and dirty water leaking out of one of the relief valve pipes on the downstream side of the safety valve, away from the tank area. The workers then set up a water spray to neutralize the leaking of MIC and the people in the control room were also informed of the situation and their corresponding actions.¹¹

December 3, 1984:

- 12.15-12:30 am: The control room operator noticed that control room pressure indicator for Tank E610 reads 25-30 psi. About 12.30 am, the control room operator found out that the pressure reading for same tank reached the maximum value of 55 psi. He found out that one of the safety valves popped out and clouds of lethal gas were discharging from the plant stack vent scrubber and spreading rapidly through Bhopal.¹¹
- 12.40 am: The plant supervisor turned on the in-plant and external toxic gas sirens. The operators also turned on the fire water sprayer. However, water could not reach the gas cloud formed at the top of the scrubber stack. Moreover, attempts to cool the tank with the refrigeration system failed because the Freon had been drained.¹¹
- 1 am: Plant supervisor realized that the spare tank, E619, was also not empty, so workers failed to reduce the pressure in E610 by transferring any MIC to E619.⁹

The gas smell was obvious outside the plant.

- 1.30 am: Bhopal police chief was informed of the leak; no significant police mobilization was followed.
- 8 am: Madhya Pradesh governor ordered closure of the plant and arrest of the plant manager and 4 other employees.

3.2 Causes of the Release

A detailed analysis of the accident has shown that safety management was poor at the plant level. The disaster that happened at the plant was a result of poor zoning and industrial siting procedures, poor emergency management procedures, and poor safety regulatory frameworks.¹² The causes of the releases behind the disaster were classified into three errors: hard, human, and system errors.

1. **Hard Errors:** The workers in the industry were informed to wash the pipelines with water without placing slip blind isolation plates. The washing is normally done after inserting a slip blind near the valve to close off the rest of the system. Slip blinds are mostly used for hydrotesting piping. When maintaining equipment or piping, the equipment or piping must be isolated to ensure a safe working environment.¹³ Because of this, and of the bad maintenance, the workers consider it possible for water to have accidentally entered the MIC tank. Since MIC polymerizes easily, phosgene is added while storing MIC to avoid the initiation of polymerization. As the water entered the MIC tank, it reacted with phosgene and generated hydrochloric acid, which is a catalyst for the polymerization of MIC.¹² The environment helped the reaction to proceed, as high temperatures, containments and other factors helped to speed the reaction. The reaction took place at 200 °C and 180 Psig, which forced the emergency vent scrubber to release a large volume of toxic gases. The reaction increased and accelerated more due to the presence of iron that resulted from corroding non-stainless steel pipelines.¹⁰ The ferric ions also catalyze MIC polymerization. Reaction of water with MIC (catalyzed by the presence of ferric ions and hydrochloric acid) initiated the polymerization, which is an exothermic reaction.¹²

None of the workers was aware of the runaway reactions that were taking place in the storage tank between water and MIC. Therefore proper emergency steps were not taken.

Another important cause was the bad structural design. The design of the vent gas scrubber was constructed to handle a flowrate of 88 Kilograms of MIC per hour. However, the actual flowrate was 20,000 Kg/hr during the time of the accident.¹² Moreover, the storage systems were designed to carry 5 tons on a daily basis. However, during the accident, there were three storage tanks and 55 tons of MIC

was stored. Large scale storage without a proper safety system was a major hard error.¹²

Most of the safety systems were not functioning and many valves were in poor condition. The pressure control valve for the MIC storage tank (610) had not been working for over a month. The pressure gauge of the MIC relief valve was only reading 10 psi, whereas the actual pressure value exceeded 40 psi.¹²

The refrigeration unit (30 tons capacity) was used to keep the MIC cool below 5 °C. However, it was shut down, and the MIC was kept at ambient temperature .¹⁴

Another important cause behind the Bhopal gas disaster was the malfunctioning of the temperature sensor for the MIC storage tank for almost four years. Thus, the regular recording of the temperature in the log sheets had not been done. This factor was not important as some officers declared, but it could have warned of the runaway reaction that occurred much earlier.¹⁵

2. **Human Errors:** The operator failed to recognize the entry of water into the MIC tank. The process took more than an hour for him to be aware of the reaction in the tank. Moreover, the operator ignored the rise in pressure from 3 psi to 10 psi; he did not consider it to be a serious problem.¹² Even when the shift occurred, the previous operator failed to inform the current operator about the rise in pressure; this results in communication error between the workers.
3. **System Errors:** There was poor examination and follow up in the Union Carbide Industry despite the previous accidents and warnings that took place before this disaster. There were not any systematic procedures made to improve the safety regulations. Moreover, insufficient operational procedure took place in examining the status of the valves when the MIC tank failed to get pressurized. In addition, an empty tank for the evaluation of MIC was not used and the operator failed to switch on the vent gas scrubber.¹²
4. Additional Causes Behind the release of the MIC taken from an article called *The Unfolding of Bhopal Disaster*¹⁵ were:
 - The vent gas scrubber was not operating at the time of the accident.
 - The flare tower had been under maintenance since November 25, 1984 and maintenance was not completed until the accident. The job could have been completed within 8 h but for the shortage of staff.
 - Fire and rescue squad (emergency squad) members were not qualified and trained to handle such an accident.
 - There was no maintenance supervisor for the night shift.

3.3 Leak Development and Gas Dispersion

Figure 4 below shows a schematic diagram for the MIC plant with numbers indicating the corresponding units or valves. As mentioned, strong reaction was initiated as water entered Tank 610. Water entry to the tank was through the jumper lines crossing valve 1 and valve 2, valve 3 and blow down DMV 4, and through valve 12. Water reacted with phosgene and generated hydrochloric acid, which is a catalyst for the polymerization of MIC.¹² The reaction increased and accelerated more due to the presence of iron that resulted from corroding non-stainless steel pipelines.¹⁰ The MIC leaked out of the tank to the atmosphere through the same route by which the water entered, and then through the relief valve vent header (RVVH). This incident clearly indicates the main factors of causing the accident are: the jumper line connection, the leaking bleeder, and a leaking DMV. If the PVH and RVVH had been connected through the jumper line, water would not have leaked into the tank. If MIC tank 610 was not getting pressurized, then the blow-down DMV should have been checked and replaced.¹⁰

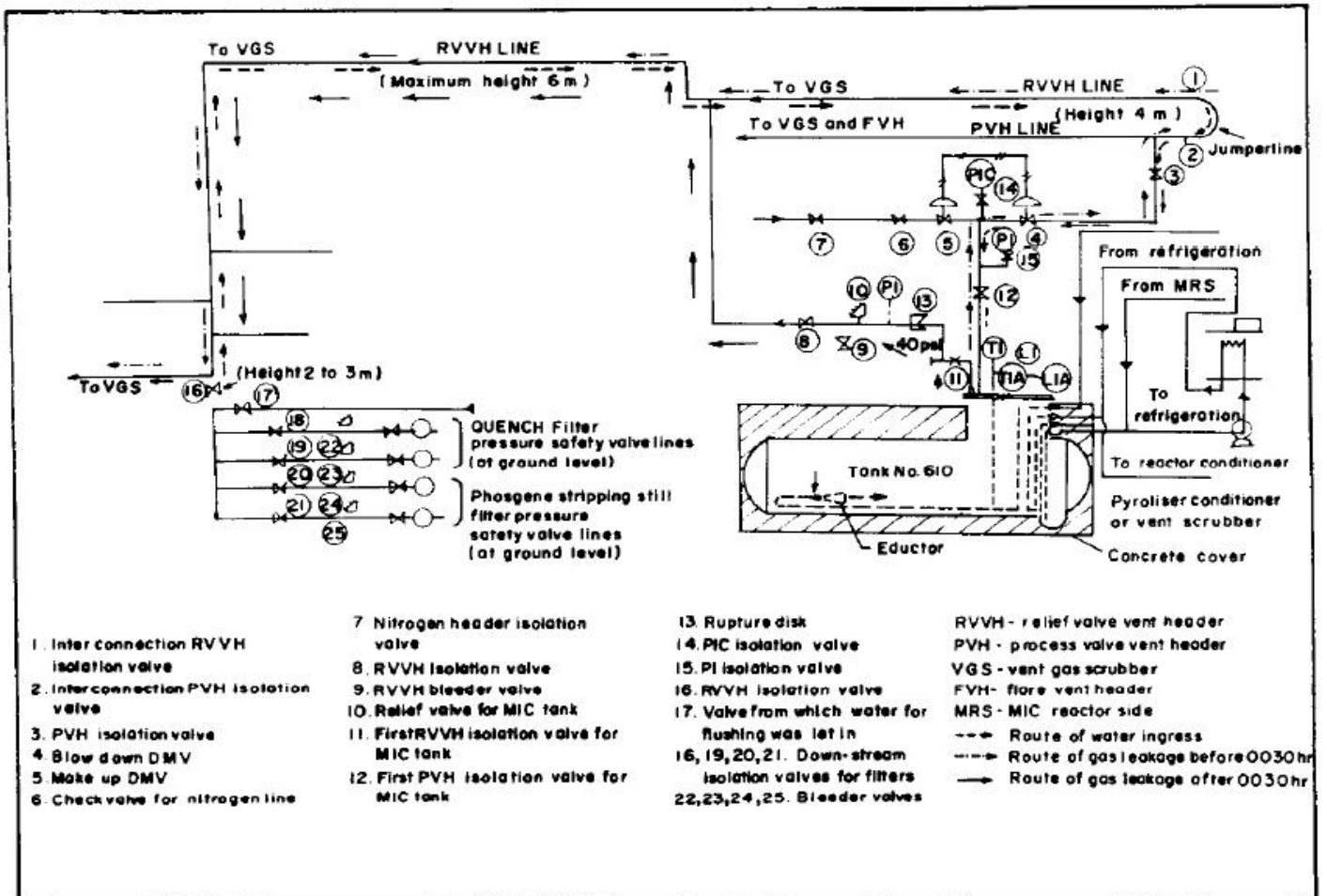

Figure 4: The MIC Plant¹⁰

The gas cloud, consisting of methylisocyanate, its decomposition products, and its reaction products, began to disperse in neighboring areas close to the Union Carbide Industry. Many people began to be affected by the dispersion. On early hours of December 3, 1984, about 12,000 people had gone to the Hamidia Hospital.¹² Moreover, residents nearby the plant had died from exposure to MIC and its decomposition products. This was not the case only, but even during the night of December 3 and early hours of December 4, 1984, the MIC cloud recondensed all over the city. More people were affected and about 55,000 patients came to the local hospital. According to the official estimates, about 2500 persons died.¹² Figure 5 below shows the gas affected area in the Bhopal city by the shaded region.

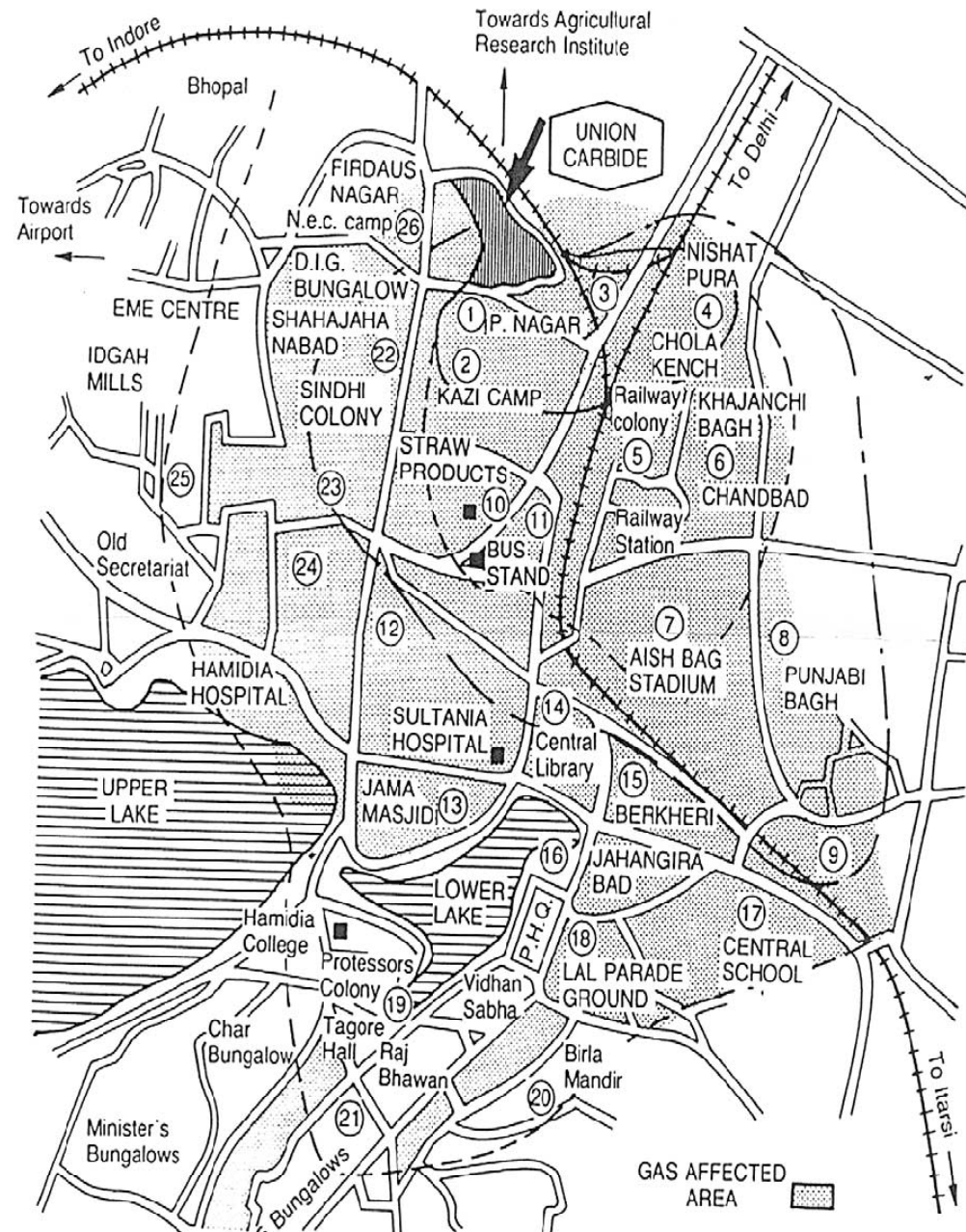

Figure 5: affected areas of Bhopal City (shaded region)¹⁶

3.4. Emergency Planning and Response:

Although many causes lead to the Bhopal disaster, there seems to be a general agreement that offsite emergency response plans, procedures, and actions were below the general standards. The Union Carbide Industry lacked automatically controlled safety devices. The plant relied heavily on manual control devices. For similar sized hazardous plants in Europe, warning systems and sensors detecting leaks are often connected to a telephone system to automatically dial out alerts. However, in Bhopal, there weren't even any emergency planning measures and local authorities knew nothing about the dangers of MIC.¹⁷ Emergency planning should involve all of the emergency services and public broadcast systems. Moreover, a 30,000 gallon dump tank should be kept empty and ready to receive any run-off MIC.¹⁷ Another important drawback was the reduction of the work force by half from 1980 to 1984 and the period of safety training to the workers from 6 months to 15 days only.

After the incident, one of the lessons learned was the design of proper emergency planning and response in case of any chemical toxic releases. The United States issued legislation in 1986 to plan and design specific emergency response activities for chemical releases.¹⁵ This legislation contained: emergency planning, emergency release notification, hazardous chemical storage reporting requirements, and toxic chemical release inventory.¹⁵

3.5 Consequences:

1. **Death rates:** For the first two days after the disaster, the death rate in some affected areas reached 20 per thousand of population. In the month of December 1984, the death rate raised to 24 per thousand as compared with the national average of 1 per thousand for a corresponding period. The highest death rate was 33 per thousand for the age group less than 5 years, followed by 15 per thousand in both the age group of 15-40 and above 45 years.¹⁸ Although not all the dead bodies were found immediately, around 311 bodies were received on the 3rd of December, followed by 250 bodies found on the 4th of December 1984. The total number of dead bodies received in December 1984 following the disaster was 837 dead bodies.¹⁸ Of the more than 200,000 people exposed to the gas, the death rate exceeded 2,500 after 1 week of the accident. In November 1989, the Department of Relief and Rehabilitation, Government of Madhya Pradesh, placed the death toll at 3,598, and by 1994 the toll was estimated at 6,000.¹⁹
2. **Health Effects:** The exposure of MIC resulted in a severe eye irritation and blindness. Most symptoms included burning sensations of the eyes and throat and coughing. "Moreover, it has caused respiratory diseases such as chronic bronchitis and emphysema, ophthalmic problems like chronic conjunctivitis and early cataracts, neurological disorders such as memory and motor skills, psychiatric problems of various types including varying grades of anxiety and depression, musculoskeletal problems and gynecological problems among the victims".²⁰ Estimations showed that

born children in Bhopal after the accident face twice the risk of dying as do children in other areas.²⁰

4. Bhopal: Investigations and Lessons

4.1 Introduction:

Union Carbide described Bhopal with words like accident, disaster, catastrophe, crisis, sabotage, conspiracy, massacre, and experiment all which tend to shun the issue of direct responsibility. In our analysis we shall describe Bhopal as a tragedy, because in calling it a tragedy we are allowed to consider that intent and offense played a role on how the event unfolded and that ultimately someone has to take the blame, without necessarily having to 'pin' the blame onto some diabolical marauding human guinea pigs bent on sabotaging the life of thousands of poor families. In contrast, we would like to think of it as a complex glut of injudicious intentions combining in the most unfortunate way possible.²⁸

Many theories have been proposed as to what actually happened in Bhopal, many of which were created by the media immediately after the incident for publicity purposes and almost all of them faulty. In this section, we shall consider the two most exhaustive investigations carried out by both the Indian Government and Union Carbide respectively. But before that, we shall talk about the safety failures within the plant, in addition to Union Carbide and the Indian Governments responsibility for the incident.

4.2 They had it coming: Union Carbide- A history of negligence:

4.2.1 Safety failures at Union Carbide's plant: FACTS

Union Carbide lacked a damning number of safety and security measures that a similar US based plant would have considered necessary for operation. Despite Union Carbide's claims that the plant was held at the same operational standards as its US equivalents, investigations of the plant proved otherwise. The following are some of the serious failures present at the Bhopal plant.

→Operational and safety failures:

The following is a list of equipment failure present at the Union Carbide plant prior to the incident

1. Storage of MIC for a period longer than permissible
2. Chloroform was fully not separated from MIC before storage, this played an important role in the runaway reaction.²²
3. Non functional and nonexistent detection and warning devices

4. Temperature and pressure gauges at various parts of the plant were extremely faulty and were generally ignored by workers
5. Insufficient and untrained staff
 - a. Faulty pipe washing
 - b. Storage of contaminated MIC
6. Failure of Union Carbide to respond to defects and lapses pointed out earlier
7. Shutdown of MIC refrigeration unit
8. Shutdown of caustic soda spray system
9. Out of order flare towers
10. Excess MIC in the tank
11. Lack of a spare tank for diverting MIC from the main tank, the emergency tank present to hold any excess MIC was being used for something else
12. Misinformation about the toxic effects of MIC and the treatment
13. No valves to prevent water entering the tank
14. Safety devices defective:
 - a. Vent gas scrubber lacked sodium hydroxide for neutralizing the gases; it was also not prepared to handle the high pressures reached during the tragedy.
 - b. Pipe leading to the flare tower had been dismantled for repairs and could not be used to burn escaping gases
 - c. Water curtains around the plant could not be used because they lacked sufficient pressure to reach the height of the release
 - d. Lack of coolant in the MIC tank refrigerator

→**Management failure:**

1. Union Carbide claimed MIC is merely “ a mild throat and ear irritant”
2. Sloppy safety procedures
3. Management neglect of general plant operations
4. Lack of investment in plant safety
5. Cost cutting:
 - Employee training and factory maintenance were radically cut.
 - Skilled employees were replaced with lower paid workers
 - Stainless valving and pipes were replaced with Carbon Steel
6. No on-site emergency plan
7. Locating the plant in a densely populated area
8. Haphazard urbanization in surrounding areas
9. Indian government’s acceptance of the plant for political reasons without any safety analysis
10. Failure of Indian government to identify hazards and mandate safety standards
11. The lack of written reference manuals/instructions for the workers’ reference
12. Data logging of both technical and general activities was not enforced by management.

4.2.2 Previous Incidents at the Union Carbide plant: FACTS²¹

Union Carbide had a history of safety failures, yet they never seemed to invest heavily in that direction. The following is a list of previous incidents that resulted in casualties at Union Carbide, this list does not include the various hazardous waste, pollution and other incidents at Union Carbide over the years.

- 1930: Hundreds of Union Carbide workers die from acute silica poisoning during the construction of a hydroelectric power tunnel Near Hawk's Nest, West Virginia.
- 1973:
 - Three employees killed, Puerto Rico, Penuelas complex.
 - One employee killed from a Benzene gas leak, Puerto Rico, Penuelas complex.
 - One employee killed by propane fumes at Institute, West Virginia.
- 1975: Six employees dead from an explosion at Union Carbide's polyethylene plant, Antwerp, Belgium.
- 1978: One employee electrocuted at Union Carbide's Eveready battery plant, Jakarta, Indonesia.
- 1980: 18 workers died of brain cancer at Union Carbide's Petrochemical Texas City Facility as reported by U.S. Departments of Labor and Health & Human Services reported
- 1981:
 - Fire at Union Carbide's graphite electrode plant, Yabucoa, Puerto Rico.
 - More than half of Union Carbide's employees in Indonesia are reported to suffer from kidney disease due to exposure to mercury levels twenty times more than that acceptable in the US
- 1982:
 - Hydrogen chloride leak at Union Carbide's Massey yard, South Charleston, West Virginia. Hundred of residents evacuated, some were hospitalized.
 - Acrolein tank explosion, Taft, Louisiana. Pressure wave destroyed windows within a mile and a half radius, thousands were evacuated.
- 1983: Significant increase of cancer deaths reported among workers at Union Carbide's plant. Seadrift, Texas.

- **1984 December 2-3. Bhopal, India: disaster killed thousands of people.**
- **1981: One worker splashed with phosgene. In panic he ripped off his mask, inhaling a large amount of phosgene gas; he died 72 hours later.**
 - **1982 January: 24 workers hospitalized due to a phosgene leak. None were wearing protective masks.**
 - **1982 February: 18 workers affected due to an MIC leak .**
 - **1982 August: A chemical engineer hospitalized with burns in over 30% of his body after coming into contact with liquid MIC.**
 - **1982 October: Three workers suffered severe burns and exposure after attempting to stop a leak of MIC, methylcarbaryl chloride, chloroform and hydrochloric acid.**
 - **During 1983 and 1984, several leaks occasionally took place at the plant.**
 - **1982: Union Carbide inspection team indicated that the plant at Bhopal, India was unsafe.**
 - **September 11, 1984: An internal Union Carbide memo warned of a "runaway reaction that could cause a catastrophic failure of the storage tanks holding the poisonous [MIC] gas" at the Institute, West Virginia plant. The memo was ignored and never reached senior staff . The memo was released in January 1985 by U.S. Representative Henry Waxman (D-CA), Chairman of the House Health and the Environment Subcommittee.**
 - ***"Now, we can confidently say," he said smugly after the investigation, "it can't happen here." By "here" Browning meant America not India. In an attempt to appease the American public, who mattered the most.***²⁸
- **1985:**
- **Around 2000 tons of acetone and mesityl oxide leaked from a distillation column at Union Carbide's plant in South Charleston, West Virginia.**
 - **Six workers and more than a hundred residents were hospitalized at Institute, West Virginia when Union Carbide's plant leaked methylene chloride and aldicarb oxime, chemicals used to manufacture the pesticide Temik.**
- **1986:**
- **February: One employee killed in a coal crusher at Institute, West Virginia.**

- April: OSHA's investigation of Union Carbide's Operations in Institute, West Virginia discovers an alleged 221 violations of 55 health and safety laws, fines Union Carbide \$1.4 million. 72 of these violations were classified as serious with a substantial probability of death or physical harm.
- 1988: August: Institute, West Virginia
 - Fire and explosion of around 1500 tons of ethylene oxide.
 - Tetranaphthalene spilled into the Kanawha River, killing 3,000 fish.
- 1990: Seven workers were injured and around 15000 residents ordered to remain indoors after MIC leaked at Union Carbide's plant at Institute, West Virginia.
- 1991:
 - March: One worker dead and 26 other injured due to an ethylene oxide explosion at Union Carbide's Seadrift plant, Texas.
 - December: One employee killed due to an asbestos tank explosion at South Charleston, West Virginia.
- 1993:
 - February: Large amounts of benzene, around 7,000 tons of methane, 18,500 tons of ethylene, and 12000 tons of by product gases were spilled at Texas City, Texas.
- End of Union Carbide- 1999 September: Dow Chemical overtakes Union Carbide for \$11.6 billion.

4.3 Previous Investigations and results:

The tragedy spiraled immediate media attention, and immense pressure was placed to quickly identify the cause of the incident. The media heavily publicized the event and many false theories were developed in an attempt to garner popular appeal. Investigations were started immediately by the Indian Government, and Union Carbide was denied access to any of its facilities or to interrogate any of the workers. Union Carbide took the case to US courts, eventually forcing the Indian Government to allow them to investigate the tragedy almost a whole year after its occurrence. Investigations resulted in two major theories, developed by the Indian Government and Union Carbide respectively, as to what actually happened that night; these will be discussed in the upcoming sections.

4.3.1 The Indian Government Version: Water Washing Theory^{25,34}

The water washing theory began circulating days after the incident and was fueled by the media. It claimed that an operator's failure to insert a slip-blind, which is required by plant operating procedures, while washing sections of a sub header of the relief valve vent

header (RVVH) at the MIC unit resulted in water flowing back into the tank located more than 400 feet away. Washing pipes with water to remove clogs and corrosion was a commonplace practice at the plant.

This theory was very popular with the media and the public, despite plant engineers declaring it highly implausible, later investigation declared it false as it failed to withstand even minimal scientific scrutiny. Despite all these results, the Indian Government remained loyal to its findings.

The Indian government investigations concluded that the following scenario occurred on December 2 1984:

- 10:20 p.m.:
 - the pressure in Tank 610 was at 2 psig . This is normal and indicates that no reaction has taken place yet.
- 10:45 p.m.:
 - Start of shift change, the shift change takes at least half an hour during which the MIC storage tanks are completely deserted
- 11:30 to 12:45 p.m.:
 - MIC reaction with water was initiated and MIC together with carbon dioxide were carried through the header system and out of the stack of the vent gas scrubber
- 11:30 p.m.:
 - A small MIC leak reported downwind in vicinity of the MIC unit
 - When notified, the supervisor said that he would deal with it after tea which went from 12:15 a.m. to 12:40 a.m.
- 12:40 p.m.:
 - Control room operator observes sharp rise in pressure within the tank.
- 12:45:
 - Safety valve opened and the gas escaped out of the scrubber.
 - Workers start transferring around one ton of the tank contents to the SEVIN unit, trying to get the water out.
- Next morning:
 - Not realizing the gravity of the tragedy, the workers involved during the previous night altered logs to disguise their involvement.

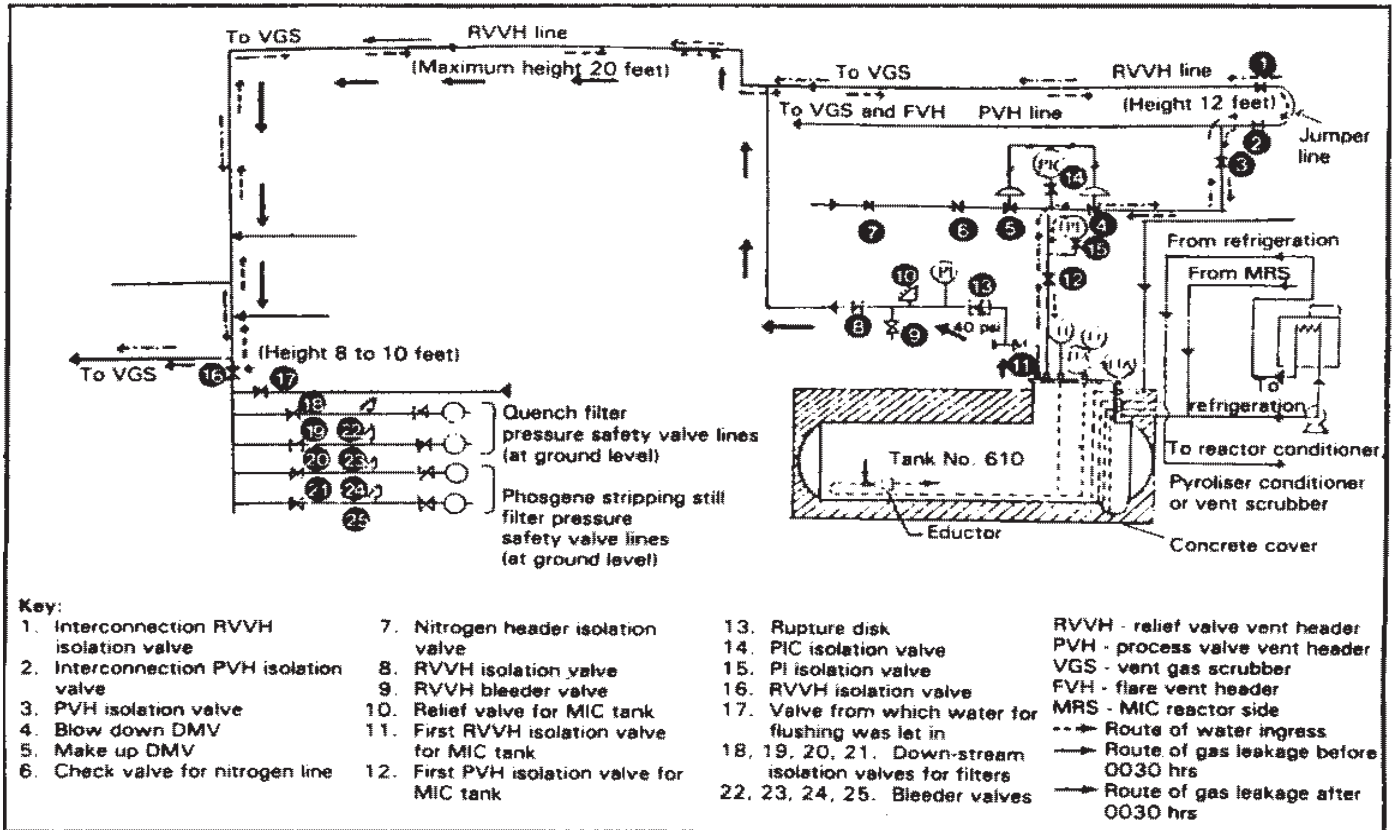

Figure 6: Flow diagram of the Tank 610 system

Feasibility:

Union Carbide's Investigation discredited the Indian Government's theory as implausible and scientifically impossible; they had the following points against the theory:

1. The water was introduced through the 0.5 inch inlet valve 17 (Figure 6), the difference in head between this point and the tank inlet was around 10.4 feet, whereas the three open bleeder valves would have limited the water pressure to 0.7 ft.
2. The valves between the tank inlet point and the tank should have been open or not tight proof for the water to enter the tank. Whereas Union Carbide claims that one of these tanks had been shut since November and was given a one hour test during which no water leaked through it.
3. For the water to have reached the tank, it would have needed to completely flood the whole piping system leading to the tank. This included a 6 in. diameter connecting pipe, 65 ft of 8 in. RVVH with numerous branches coming off and around 340 ft of 6 in RVVH, this would need an estimated 4500 lb of water. The piping system had no bleeders or flanged joints and should have been filled with water for the hypothesis to suffice, nevertheless they were found to be completely dry.

4.3.2 The Union Carbide Version: Sabotage theory^{25,34}

Union Carbide's Investigation discredited the Indian Government's theory as improbable. They instead proposed the scenario of sabotage during the shift period when the plant was left unattended.

Union Carbide's insistence on sabotage has been considered by many 'the easy way out' in an attempt to appease the American public and protect its image in the United States. Their statements about the tragedy lacked any sense of responsibility on their behalf; on their website Union Carbide claim that:

*"Investigations suggest that only an employee with the appropriate skills and knowledge of the site could have tampered with the tank. An independent investigation by the engineering consulting firm Arthur D. Little determined that the water could only have been introduced into the tank deliberately, since process safety systems -- in place and operational -- would have prevented water from entering the tank by accident."*²³

Their claim that safety systems were "in place and operational", despite the internal investigation by its own claiming otherwise is baffling, Union Carbide then continues its streak of outlandish passive aggressive claims :

*"The Indian authorities are well aware of the identity of the employee"*²³

*"Indian authorities refused to pursue this individual because they, as litigants, were not interested in proving that anyone other than Union Carbide was to blame for the tragedy. The fact that employee sabotage caused the disaster under existing law would have exculpated Union Carbide"*²³

There have been two theories regarding the motives behind such sabotage:

The first one claims that the Indian government's political agenda has fueled the incident; basically the Hindu led Indian government has been sparring with Sikh militants for a while²²:

- June 1984: Indira Gandhi orders Operation blue star which kills around 500 Sikh separatist and destroys their sacred shrine in the Indian State of Punjab
- October 1984: Indira Gandhi gets killed by her Sikh bodyguards
- Hours after the assassination: Violence and assassinations targeting Sikh's erupts in Delhi and other cities which last for three days, around 3000 Sikh's are killed.
 - These mass assassinations are unexpectedly endorsed by India's new prime minister Rajiv Gandhi (Indira Gandhi's son), who declared: *"When a mighty tree falls, it is only natural that the earth around it does shake a*

little,"²²

- Union Carbide makes use of the recent unrest among Sikh supporters and given that Bhopal is a Hindu province; Union Carbide tries to play that card.

Union carbide's president Warren Anderson even went ahead to declare that the incident was caused by 'Sikh Terrorists' from an organization called 'Black June'²⁹. Such a cynical claim against the Indian Government was met with wide scale skepticism and derision and has resulted in increased tension between the company and the Indian Government. Union Carbide then rapidly changed its story to claim that the incident was caused by a disgruntled employee.

The second theory claims that a dissatisfied employee, unhappy with his recent transfer to a separate part of the plant, decided to take matters into his own hand. This worker was described as being disgruntled at being transferred to the Sevin plant but remained "illegally" at the MIC unit, he was later found out to be Mr. Mohan Lal Varma [8].

Mr. Varma joined Union Carbide's alpha-naphthol on 28 March 1977. He claims to have had six months of classroom training, but no actual practical onsite training. The naphthol plant proved to be a failure and plans for large scale modifications were in action. When the plant was restarted, it still failed to meet expectation and was closed permanently, laying off all the operating staff including Mr. Varma.

Mr. Varma was then sent for theoretical training at the MIC plant, he passed a qualifying exam and was selected to become an MIC unit operator. He had no practical training for the job and was asked to take charge of the plant many times, when he refused to take charge because he lacked the required expertise he was given an oral warning, but never in writing since they were well aware of the legal implications it may have. Mr. Varma's continuous refusal to take charge resulted in a threat of being transferred to other units by the MIC plant manager S.P. Choudhry in November of 1984. Mr. Varma demanded he gets proper training before taking the job and also requested that if transferred, he wanted it to be declared in writing so that he can take legal action.

Things then become slightly bizarre, Mr. Varma was given an oral test by S.P Choudhry about the MIC plant, which he predictably, due to his lack of training, failed miserably. S.P Choudhry then ordered him to be transferred to the Sevin plant due to his incompetence.²⁶ His transfer was never documented in writing nor was it mentioned on the company's notice board. This part has raised many flags, because despite claiming him ineligible to work in the MIC plant, Union Carbide have been trying for months to force Mr. Varma to take charge of the MIC unit.

Mr. Varma describes the transfer as a revenge token by S.P Choudhry for not obeying him in the past. Mr. Varma's transfer was announced on the 26th of November, around a week before the incident. He refused to transfer and continued to report to the MIC unit.

On the night of the incident Mr. Varma recollects the story as follows:

"On 2 December 1984 I was on night shift. I punched my card around 10:50 and reported to the production assistant of the MIC plant. About 11:15 P.M., I was sitting in the MIC control room along with my fellow workers. Then I went to the tea room at the 200-ton refrigeration unit. Generally, when we are free MIC operators sit in this room. The window of the tea room toward the MIC unit was open. Around 11:30, we felt MIC irritation so we came out from the room to locate the source of the leak. We saw that some water was dropping from the MIC plant structure. Near that water the MIC was in greater concentration. As we came toward the vent gas scrubber side we felt high MIC concentration. We reported the MIC leak to production assistant S. Qurashi. The plant superintendent was also sitting there in the control room. They replied that the MIC plant is down and thus there is no chance of leak. They did not take our report seriously, saying "Koi baht nahin appan chay ke bad dhekhenge" ("Okay, no problem, we'll see after tea").

In the meantime, the tea boy came to the control room and we took tea. Then the plant superintendent went to smoke a cigarette near the security gate, as it is not allowed on the plant premises. Now the time was around 12:30. With the supervisor, we went to the MIC. The operator, Khampariya, was ordered to spray water on the leaking point. The supervisor was not able to trace out the source of the leak. Around 12:50 the leak became vigorous and started coming out from, the vent gas scrubber atmospheric line. I was standing in front of the control room when the siren started. After a few minutes, the plant superintendent came back to the MIC unit. As he met me, he asked, "What happened?" I told him MIC was pouring from the top of the vent gas scrubber.

Because of the siren, the emergency squad came to the MIC unit. They tried to control the leak by massive water spraying. I also helped them until the conditions in the area became unbearable. Then along with other workers I left the MIC unit area in the opposite wind direction. The MIC production assistant also fled. When the plant superintendent came back from smoking, he ordered that the loud siren be stopped. This was around 1:00 A.M. Around 2:00 A.M. when we learned that the toxic release was affecting the communities outside the plant, we argued with the plant superintendent to restart the loud siren. He refused saying it would serve no purpose, but we insisted until he switched it on again. Around 2:15, the gas leak stopped so we returned to the MIC unit and discovered that the MIC production assistant was missing. After some time, we learned that he was lying near the boundary wall. Some workers brought him to the dispensary. Around 3:00 A.M. I saw many people from outside coming for medical help. Many were in dying condition. A managerial staff member, Roy Choudhry, and others were denying help to these people from outside. We argued with the dispensary staff, telling them that we must provide any help possible since they were affected by a leak from our factory. Finally they began to administer basic first aid. When I came to know that the area in which my family was living was also affected, I rushed home. This was around 5:00 A.M. Outside the plant; I saw how badly the gas had affected people. "26

Mr. Varma's declarations continue as he denies the possibility of direct entry of water and instead blames Union Carbide's negligent management:

"Beyond UCC lies suggesting that I am to blame, there are other reasons why the sabotage theory is clearly incorrect: it is not possible for any worker to put water directly into the MIC tank, as it is a very dangerous job. Further, everyone knows that a MIC and water reaction is very dangerous, not just spoiling the contents of the tank. So, it may be sabotage that caused the leak but not by any worker. If the leak was caused by sabotage, the culprit is the management who was responsible for overseeing the safety of the MIC plant. The leak was a result of continuous negligence, unsafe handling and a poor warning system"26

Feasibility:

Given the fact that the factory was mismanaged, run down, neglected and marked for closure due to financial losses makes us skeptical of Union Carbide's theories, especially when considering that warnings by Carbide's own safety auditors, citing the possibility of 'a major toxic release'³² were ignored and the fact that not a single one of the safety systems was working when the tragedy occurred. Moreover, the night of the plant not a single trained worker was available, and the present workers at that time panicked at the prospect of a reaction, because all they knew about MIC and water is that they reacted like eighties movie teenagers and will produce a hell of a lot of heat without really understanding how it could happen and how can they stop it.

Union Carbide's theory is based on claims that its safety devices were well equipped and prepared and the plant was up to standard, which was not the case at Bhopal, In fact investigations of the plan proved otherwise. In his book, *The Bhopal Saga*, Ingrid Eckerman mentions that tank 610 was faulty and 'misbehaved' whenever used for operation, it was reported that it could not be pressurized. Instead of taking such reports seriously, plant management just ordered the abandonment of the tank and the use of tank 611 instead, without draining the tank of its contents. During the post tragedy investigations operators have unanimously claimed the story that during tests, whenever nitrogen was pumped into the tank, it leaked out again through an unknown route.³⁰

With Union Carbide's claim of knowing the assailant one would think that revealing him to the public would have made things a lot easier when dealing with the law, this brings up another question: How is it that almost thirty years after an event of such large consequences these still has been no legal closure?

This is a classic case of corporations bullying their way out of trouble; Union Carbide simply could not afford to take the blame. The main reason behind Union Carbide's demise is the damage of its public image in the US facilitated by the media, they managed to get away with it numerous times before, but this time the magnitude of the tragedy worked against them. The tone in all of Union Carbide's documents and statements suggested that the main audience was the media in a plan to 'save face'. In his document about the incident, Jackson Browning, who was the vice president of Union Carbide at that time, had a sub section titled: "Keeping vital audiences informed" , where he mentions the media, customers, shareholders and suppliers. But nowhere in this section did he mention the people of India or Bhopal.

The fact is that the Union Carbide plant was an utter disgrace when compared to United States chemical plant regulations. Just a brief example of the magnitude of negligence practiced by the plant's management is manifested when the plant alarm started an astounding one hour after the toxic cloud had escaped only for the workers to immediately stop it in an attempt to save their jobs, most of the damage had occurred by then.[2]

4.3.3 Conclusion

Given the circumstances, we think that the truth lies somewhere in between the two investigations. We do agree, the water was directly and intentionally placed into the tank, but due to sheer incompetence rather than sabotage, as a desperate attempt by untrained workers to save the situation. What we think happened, was that a small leak was detected when some water remains from the washing process entering the tank, this leak should have been handled by either the safety systems or any trained worker, both which the plant lacked at that time. Panicking workers then decide to 'wash it off' by adding more water into the tank resulting in the tragedy, other chemicals like chloroform and rusted iron from the piping network were reported to have played a role in aggravating the reaction, but no real effort was made to further investigate the chemistry. After realizing the gravity of what they've done, the workers then cover up for each other.

Moreover, because investigations were kept secret by the Indian Government, no details are available as to how they were conducted and what the full findings were, this led to the evolution of numerous theories regarding the chemistry of the runaway reaction and what actually caused it.

5. Lessons and Observations from Bhopal³⁴

The Bhopal tragedy was a long overdue wake up call to the chemical industry, a tragedy of such magnitude has changed the chemical industry for the better; many lessons were learned from Bhopal which helped raise safety awareness within the chemical industry. Many companies and universities started incorporating process safety into its training curriculum, the United States formed the Chemical Safety board in an attempt to use the lessons learned from such Bhopal and invoke positive change within the industry to prevent future incidents and save lives.

Some of the major lessons from Bhopal outlines in Lee's Process Safety in the Chemical Industry are:

- Unlike the Flixborough and Seveso incidents, Bhopal invoked worldwide and intense publicity for a long time. This helped bring chemical process safety to the forefront, both within the chemical industry and to the general public who started perceiving it as unsafe and risky.
- Siting at major hazard installations was taken lightly before the incident, had the plant been located in a less densely populated area, such a tragedy could have been averted.
- Bhopal also brought the issue of development control into attention. Despite the area being relatively populated beforehand, the development of densely populated shantytowns which came up to the site boundaries should have been controlled and

prevented both by Union Carbide and the Indian Government.

- The tragedy shed light onto the issue of plant management and how it is important to minimize continuous changes in management and staff within a plant, especially one that needs significant levels of technical familiarity to handle due to both its location and its hazardous product. Furthermore, the issue of prioritizing safety in decision making was established, one absolutely cannot afford to cut costs by jeopardizing plant safety.

- Storage of toxic substances was revolutionized after the tragedy, one cannot be too careful when handling such toxic material, especially those that are routinely handled in the chemical industry. Inherent design safety, should be incorporated into facilities handling these materials and dispersion mechanisms should always be present and functional. There should always be a limit to the amount of toxic material one can store, process design needs to take into consideration the amount of inventory needed and try to minimize it. Moreover, guidelines on the storage of runaway reactions have been developed.

- It has established that a safety valve should only open when the pressure rise inside the vessel threatens its integrity but not with any minor pressure deviation. Nevertheless, when the risk of an excessive rise in temperature, such as the case of highly exothermic or runaway reactions, a compromise needs to be made so as when the venting starts.

- Under no circumstances shall any safety devices be disabled in a plant, it is crucial to have strict procedures for disabling any safety equipment and to try to keep it to minimum.

- Regular and effective maintenance is crucial in any plant setting, and immediate action should be taken when anything unusual is detected.

Figure 7 below shows an accident model developed by Kletz showing the different safety modifications learned throughout the process of the leak.

These are just some of the many lessons which can be extracted from the Bhopal tragedy, one which the chemical industry hopes never to witness again.

Event	Recommendations for prevention/mitigation 1st layer: Immediate technical recommendations 2nd layer: Avoiding the hazard 3rd layer: Improving the management system
Public concern compelled other companies to improve standards	Provide information that will help public keep risks in perspective.
Emergency not handled well	Provide and practise emergency plans.
About 2000 people killed	Control building near major hazards.
Scrubber not in full working order Flare stack out of use Both may have been too small	Keep protective equipment in working order. Size for foreseeable conditions.
Discharge from relief valve	
Refrigeration system out of use	Keep protective equipment in use even though plant is shut down.
Runaway reaction	
Rise in temperature	Train operators not to ignore unusual readings.
Water entered MIC tank	
.....	
Decision to store over 100 tonnes MIC	<i>Minimize stocks of hazardous materials.</i>
Decision to use MIC route	<i>Avoid use of hazardous materials.</i>
Joint venture established	Agree who is responsible for safety.
	To achieve the above: Train chemical engineers in loss prevention

Figure 7: An accident model for Bhopal showing critical events and recommendations³⁴

6. Conclusion:

The Bhopal tragedy sent shockwaves throughout the chemical industry, both the human heartbreak and the utter technical negligence came as a slap across the face for the chemical industry, provoking wide scale changes and highlighting process safety as a crucial and indispensable element at both the technical and managerial levels. Perhaps it is too late as to search for 'who' was behind such a tragedy, as the balance of power between the poor laborers and the major multinational will just carve another chapter into our book of human misery. Nevertheless, it is crucial to analyze the tragedy and try to overcome all the failures that led to it, something the chemical industry has successfully managed to achieve over the past decades.

7. References

1. Stix G. Bhopal: A Tragedy in Waiting. *IEEE Spectrum*. 1999.
2. Bowonder B. The Bhopal Accident. *Technological Forecasting and Social Change*. 1987; 32.
3. CommonDreams“Bhopal: The Hiroshima of the Chemical Industry” WWW URL: <http://www.commondreams.org/headline/2009/07/12-3> (November, 2009)
4. Varma R, Varma DR. The Bhopal Disaster of 1984. *Bulletin of Science, Technology & Society*. 2005; 25.
5. OSHA. “Methyl Isocyanate” WWW URL: <http://www.osha.gov/dts/sltc/methods/organic/org054/org054.html> (November, 2009)
6. Bowonder B, Mitaki T. Managing Hazardous Materials: Lessons from the Bhopal Accident. *Journal of Hazardous Materials*. 1988. 19.
7. TED Case Studies: Bhopal Disaster. American University, Washington DC Website.1997. Available at <http://www1.american.edu/ted/bhopal.htm>. Accessed October 23, 2009.
8. Warren Hendricks. Phosgene. Occupational Safety and Health Administration Website. 1986. Available at <http://www.osha.gov/dts/sltc/methods/organic/org061/org061.html>. Accessed October 25, 2009.
9. Bhopal Timeline: The Chronology of the Disaster. India Together Website. 2009. Available at <http://www.indiatogether.org/campaigns/bhopal/timeline.htm>. Accessed October 25, 2009.
10. Ingrid Eckerman, Sweden. The Bhopal Disaster 1984. UC Davis Computer Science Website. 2006. Available at <http://www.cs.ucdavis.edu/~rogaway/classes/188/materials/bhopal-short.pdf>. Accessed October 25, 2009.
11. . MJ Peterson. Bhopal Plant Disaster Chronology. *International Dimensions of Ethics Education in Science and Engineering*.2009. Available at <http://www.umass.edu/sts/ethics/bhopal.html>. Accessed October 23, 2009.
12. B.Bowonder. The Bhopal Accident. *Technological forecasting and social change*. 1987; 32: 169-182.

13. Jaan Taagepera, Trevor G. Seipp. Slip Blinds at Pressures Causing Permanent Deformation. ASME Digital Library. 2007; 129: 248-252. Available at <http://scitation.aip.org/getabs/servlet/GetabsServlet?prog=normal&id=JPVTAS000129000002000248000001&idtype=cvips&gifs=yes>. Accessed November 2, 2009.
14. Giby Joseph, Mark Kaszniak, Lisa Long. Lessons after Bhopal: CSB a catalyst for change. *Loss Prevention in the Process Industries*. 2005; 18: 537-548. Available at www.sciencedirect.com. Accessed October 26, 2009.
15. T.R. Chouhan. The unfolding of Bhopal disaster. *Loss Prevention in the Process Industries*. 2005; 18: 205-208. Available at www.sciencedirect.com. Accessed October 26, 2009.
16. J.K. Gehlawat. Bhopal disaster—a personal experience. *Loss Prevention in the Process Industries*. 2005; 18: 261-263. Available at www.sciencedirect.com. Accessed October 26, 2009.
17. Emily Monosson. Environmental Health. *Encyclopedia of Earth*. 2008. Available at http://www.eoearth.org/article/Bhopal,_India. Accessed November 4, 2009.
18. S. Sriramachari. Bhopal gas tragedy: scientific challenges and lessons for future. *Loss Prevention in the Process Industries*. 2005; 18: 264-267. Available at www.sciencedirect.com. Accessed October 26, 2009.
19. Rosaline Dhara, V. Ramana. The Union Carbide Disaster in Bhopal: A Review of Health Effects. *Archives of Environmental Health*. 2002; 57. Available at <https://webdrive.service.emory.edu/users/vdhara/www.BhopalPublications>. Accessed October 26, 2009.
20. Justice for Bhopal Gas Victims. International Campaign for Justice in Bhopal Website. 2009. Available at <http://old.studentsforbhopal.org/WhatHappened.htm>. Accessed November 2, 2009.
21. Chronology of the Union Carbide Corporation. Endgame Research Website. Available at: <http://www.endgame.org/carbide-history.html>. Accessed November 10, 2009.
22. Bhopal Revisited. Chemical and Engineering news Website. Available at: <http://pubs.acs.org/cen/books/85/8528books.html>. Accessed November 8, 2009.
23. Operation Blue Star. Wikipedia. Available at http://en.wikipedia.org/wiki/Operation_Blue_Star. Accessed November 1, 2009.
24. Bhopal Information Center: Frequently Asked Questions. Union Carbide Website. Available at: <http://www.bhopal.com/faq.htm>. Accessed November 2, 2009.

25. Methyl Isocyanate. Union Carbide F-41443A - 7/76. Union Carbide Corporation, New York (1976)
26. Bhopal Methyl Isocyanate Incident. Investigation Team Report. Union Carbide Corporation, Danbury, CT (1985).
27. M.L. Varma, the worker believed to be Carbide's sabotage suspect, tells his story of the night of the gas disaster and of the factory's internal politics. Source: by M.L.Varma, from T.R. Chouhan, et al., Bhopal: The Inside Story, New York: The Apex Press and Mapusa, Goa: The Other India Press, 1994, revised edition, 2004.
Available at: <http://old.studentsforbhopal.org/BhopalStories.htm#MLVarma>. Accessed November 4,2009.
28. Bogard, William The Bhopal Tragedy: Language, Logic and Politics in the Production of a Hazard SanFrancisco: Westview Press, Inc. 1989
29. EarthBase "The Bhopal Disaster" . Available at:
<http://www.earthbase.org/home/timeline/1984/bhopal/> . Accessed November 7, 2009.
30. Eckerman, Ingrid (2004). The Bhopal Saga — Causes and Consequences of the World's Largest Industrial Disaster. India: Universities Press. ISBN 81-7371-515-7.
31. Kalelkar AS, Little AD. (1998) Investigation of Large-magnitude incidents: Bhopal as a Case Study. London: The Institution of Chemical Engineers Conference on Preventing Major Chemical Accidents (Arthur D. Little Report)
32. Labunska I, Stephenson A, Brigden K, Stringer R, Santillo D, Johnston P.A. (1999). The Bhopal Legacy. Toxic contaminants at the former Union Carbide factory site,Bhopal, India: 15 years after the Bhopal accident. Greenpeace Research Laboratories, Department of Biological Sciences, University of Exeter, Exeter UK
33. Stringer R, Labunska I, Brigden K, Santillo D. (2002). "Chemical Stockpiles at Union Carbide India Limited in Bhopal: An investigation". Greenpeace Research Laboratories.
34. Frank P. Lees, Sam Mannan. Lee's loss prevention in the process industries. 3rd edition. Elsevier. 2005.

"On my honor, As an Aggie, I have neither given nor received any unauthorized aid on this academic work."