

**PRODUCTION ENGINEERING, COST ESTIMATING AND SOFTWARE  
DEVELOPMENT FOR A CUTTER SUCTION DREDGE**

A Thesis

by

KIRSTIN M HAAS

Submitted to the Office of Graduate and Professional Studies of  
Texas A&M University  
in partial fulfillment of the requirements for the degree of

MASTER OF SCIENCE

|                     |                   |
|---------------------|-------------------|
| Chair of Committee, | Robert E. Randall |
| Committee Members,  | Robert Gordon     |
|                     | Achim Stössel     |
| Head of Department, | Sharath Girimaji  |

May 2019

Major Subject: Ocean Engineering

Copyright 2019 Kirstin Haas

## ABSTRACT

Dredging is a normal and essential part of maritime commerce not only for the largest ports in the United States but also for the smallest marinas in harbors, lakes, and rivers. Dredging projects are often awarded to local contractors via a competitive bidding process. To appropriately estimate the final cost for individual dredging projects, contractors need accurate programs to compile known information about the project, and use this information to accurately estimate the dredging cost. This thesis describes a program to accurately determine the production rate and cost estimate for cutter suction dredges, using minimal information from the dredging site and the dredge being used.

The program used for the cutter suction dredge cost estimation incorporates the production rate and final cost estimation. The production rate is found first and used to estimate the project duration and total dredging cost. Using the Cutter Suction Dredge Cost Estimating Program (CSDCEP) developed from MS Excel, a user can add specific project information for a more accurate result. The CSDCEP uses the MS Excel interface, making it publicly available and incorporates fluid mechanics, dimensionless pump curve analysis, and current economic data, to create a reliable, customizable program regardless of the amount of user input.

Sixteen dredging projects including four beach nourishment projects completed between 2016 and 2018 were selected from the U.S. Army Corps of Engineers, the winning bids were compared with the final cost estimates from the Cutter Suction Dredge Cost Estimating Program.

CSDCEP accurately estimated the winning bids with a mean absolute percent difference of 10% for the dredging projects chosen and 9% for the beach nourishment dredging operation costs.

## **ACKNOWLEDGEMENTS**

I would like to thank my committee chair, Dr. Robert Randall, and my committee members, Dr. Robert Gordon, and Dr. Achim Stössel, for their guidance and support throughout the course of this research.

## **CONTRIBUTIONS AND FUNDING SOURCES**

### **Contributors**

This work was supervised by a thesis committee consisting of Professor Randall of the Department of Ocean Engineering, Professor Gordon of the Department of Ocean Engineering, and Professor Stössel of the Department of Oceanography.

All other work conducted for the thesis was completed by the student independently.

### **Funding Sources**

Graduate study was supported by the United States Coast Guard Office of Marine Engineering.

# TABLE OF CONTENTS

|   | Page |
|---|------|
| ABSTRACT .....  | ii   |
| ACKNOWLEDGEMENTS.....   | iv   |
| CONTRIBUTIONS AND FUNDING SOURCES .....                         | v    |
| TABLE OF CONTENTS .....   | vi   |
| LIST OF FIGURES .....   | viii |
| LIST OF TABLES.....   | x    |
| INTRODUCTION .....  | 1    |
| Dredging Overview .....   | 1    |
| Objectives .....  | 3    |
| CUTTER SUCTION DREDGE .....                                     | 4    |
| REVIEW OF LITERATURE .....                                      | 8    |
| METHODOLOGY FOR ESTIMATING PRODUCTION .....                     | 12   |
| Hydraulic Transport.....  | 12   |
| Critical Velocity.....  | 20   |
| System Head Losses .....  | 23   |
| Friction Factor .....   | 26   |
| Dimensionless Pump Characteristics Curves .....                 | 32   |
| Total Production Rate .....                                     | 35   |
| U.S. Army Corps of Engineers Method of Production Estimate..... | 38   |
| DEVELOPMENT OF THE COST ESTIMATE .....                          | 40   |
| Fuel .....  | 41   |
| Capital Cost .....  | 41   |
| Repairs and Maintenance.....                                    | 42   |
| Pipeline .....  | 42   |

|  | Page   |
|--|--------|
| Depreciation.....                          | 43     |
| Insurance.....                             | 43     |
| Overhead.....                              | 44     |
| Crew and Labor .....                       | 44     |
| Mobilization and Demobilization.....       | 45     |
| Cost Factors .....                         | 46     |
| Beach Nourishment .....                    | 46     |
| <br>USING THE COST ESTIMATING PROGRAM..... | <br>49 |
| Program Organization.....                  | 49     |
| Data Input .....                           | 49     |
| Defaults.....                              | 54     |
| Mobilization and Demobilization .....      | 57     |
| Data Base .....                            | 58     |
| Production.....                            | 58     |
| Head Loss .....                            | 60     |
| Critical Velocity.....                     | 61     |
| Net Positive Suction Head .....            | 61     |
| <br>RESULTS .....                          | <br>62 |
| Cost Comparison .....                      | 62     |
| Sensitivity Analysis .....                 | 68     |
| <br>CONCLUSION AND RECOMMENDATIONS .....   | <br>75 |
| <br>REFERENCES .....                       | <br>78 |
| <br>APPENDIX A USER’S MANUAL .....         | <br>81 |

## LIST OF FIGURES

|   | Page |
|---|------|
| Figure 1: Typical Cutter Suction Dredge and Components.....   | 4    |
| Figure 2: Cutter Suction Dredge: Method of Advancing.....   | 7    |
| Figure 3: Schematic of Reference Points 1 and 2.....  | 13   |
| Figure 4: Sediment Distribution in a Pipeline.....  | 15   |
| Figure 5: Nomograph for Estimating Critical Velocity in Slurry Pipelines (Wilson et al. 2006)               | 21   |
| Figure 6: Effect of Angle of Inclination on the Critical Velocity (Wilson & Tse, 1984).....                 | 22   |
| Figure 7: Picture of HDPE Piping (Performance Pipe 2018).....   | 31   |
| Figure 8: Picture of Steel Piping (HI-SEA Marine 2018).....   | 31   |
| Figure 9: Pump Characteristics Curve (GIW Industries, 2003).....  | 34   |
| Figure 10: Example of System Head Curve Superimposed on Pump Head Curve.....                                | 35   |
| Figure 11: Example of a Beach Nourishment Project.....  | 47   |
| Figure 12: Bank Factor Determination (Turner, 1996).....  | 52   |
| Figure 13: Dimensionless Characteristics Curve.....   | 60   |
| Figure 14: Comparison of Program Estimate, Government Estimate, and Winning Bids for<br>Large Projects..... | 66   |
| Figure 15: Comparison of Program Estimate, Government Estimate, and Winning Bid for<br>Small Projects.....  | 67   |
| Figure 16: Comparison of Beach Nourishment Project Costs.....   | 67   |
| Figure 17: Variation of Cost with Bank Height: 30-inch Dredge.....  | 70   |
| Figure 18: Variation of Cost with Discharge Pipeline Length: 30-inch Dredge.....                            | 71   |
| Figure 19: Variation of Cost with Volume Dredged: 30-inch Dredge.....                                       | 72   |
| Figure 20: Variation of Cost with Sediment Type: 30-inch Dredge.....  | 73   |



Figure 21: Variation of Cost with Dredge Size: 30-inch Dredge ..... 74

## LIST OF TABLES

|   | Page |
|---|------|
| Table 1: Minor Loss Coefficients (K) for Common Dredge Components .....             | 25   |
| Table 2: Values of Absolute Roughness $\epsilon$ for Pipes.....                     | 29   |
| Table 3: USACE Estimate Production Chart.....                                       | 39   |
| Table 4: Cutter Suction Dredge Properties from Main Data Input Sheet .....          | 50   |
| Table 5: Final Cost Estimate Example from Main Data Sheet Input .....               | 54   |
| Table 6: Defaults Page in Cutter Suction Dredge Cost Estimating Program .....       | 55   |
| Table 7: Relationship from Dimensional to Nondimensional Pump Characteristics ..... | 59   |
| Table 8: Projects used to Compare Cost Estimates .....                              | 64   |
| Table 9: Percent Difference Between Estimated and Actual Costs.....                 | 65   |
| Table 10: Cutter Suction Dredge Cost Estimating Program Estimate Values.....        | 69   |

# INTRODUCTION

## **Dredging Overview**

Removing sediment from the bottom of a body of water and moving it to another place, either onshore, or in a placement area, is called dredging. Often, the removed sediment can be beneficially used in other projects such as land restoration or beach nourishment. Most coastal communities, ports, and harbors across the United States use dredging to deepen and maintain navigational waterways, and often to increase coastal land area. As a vital part of the marine transportation system, the average dredging costs from 1996 to 2017 was \$1.07 billion dollars each year. The average dredging cost per cubic yard was \$4.67, with a total volume of 238 million cubic yards dredged each year in the United States (USACE 2017). Dredging provides widespread positive impacts such as deepening the shipping channel in the Columbia River, for larger container vessels and bulk carriers to conduct trade in the Pacific Northwest, to emergency dredging in New Jersey, repairing the waterways and beaches after Hurricane Sandy.

There are two methods of dredging: hydraulic and mechanical. Hydraulic dredging uses a pump to move sediment particles suspended in water for removal and transportation. Mechanical dredging lifts the sediment out of the water, mainly excavating the dredged material using buckets. The cutter suction dredge is the most prolific type of hydraulic dredge, and the most versatile. Cutter suction dredges provide the advantage of moving dredged material hydraulically to a placement area without the need to re-handle the sediment. Cutter suction dredges have the ability to dredge and work 24 hours a day as the dredge can pump the slurry directly to a

placement site. As the most prevalent dredge, cutter suction dredges account for approximately 70% of the total dredging work done in the United States, with over 1 billion dollars spent from 2016-2017 (USACE 2017), with many of these projects being funded by the U. S. Army Corps of Engineers (USACE). The U. S. Army Corps of Engineers is a U.S. federal agency and is the world's largest public engineering, design, and construction management agency. The USACE's mission is to "deliver vital public and military engineering services; partnering in peace and war to strengthen our Nation's security, energize the economy and reduce risks from disasters" (USACE 2017). By performing emergency work using their own dredges or awarding dredging contracts to commercial companies based on competitive bidding, the USACE is a major part of the dredging industry in the United States.

Dredging contracts are commonly awarded through a competitive bidding process, a standard in industry and in government work. A competitive bidding process consists of several companies bidding on the final cost of a dredging project. Usually, the contractor with the lowest sensible bid is awarded the final dredging contract. Having the most competitive and accurate estimate on a bid enhances the likelihood of obtaining the contract and profits associated with the project. Inaccurate or mistaken estimates, however, cost bidding companies time, profit, or business. Ill-conceived bids are equally problematic for the entities who need to evaluate the bids. The public or agency that wants to complete dredging work also needs a way to accurately check the contractor's bids. If the winning bid is too low for a project, there can be delays or costly additions to the initial bid. Likewise, if the bid is too high, there might be unnecessary waste and spending.

Cost estimates are based on volume of material excavated, dredging location, discharge location, site conditions, environmental restrictions, and available dredging equipment. The more detailed information provided in an estimate, the more accurate production rates and costs can be determined. The final cost of the project is estimated using the dredging production rate. When the production rate is higher, a dredging project can be completed earlier and have a lower cost. If the production rate is lower, the project will take more time and have a higher cost.

## **Objectives**

The objective of this thesis is to develop, assess, and validate a user-friendly MS Excel software program to accurately estimate the production and final cost of cutter suction dredge projects. Included in the Cutter Suction Dredge Cost Estimating Program are cost estimates for beach nourishment dredging projects, up to date non-dimensional pump characteristics curves, dredge project production rate calculations, critical velocity determination, net positive suction head calculations, booster pump requirements, and an estimated final cost, cost per cubic yard of dredged material, and time to complete the project. The cost estimating spreadsheet developed is available to the public. Building on previously developed cost estimating software from the Center for Dredging Studies (CDS) by Miertschin (1997), Miertschin and Randall (1998), and Auger (2012), this research updates dimensionless pump characteristics curves used to apply the program to any size dredge pump, including a manual entry of dredge pump characteristics, and includes the need for a ladder pump or booster pump. The updated program also has the ability for the user to specify if the dredged material is used for beach nourishment. By inputting known or estimated information from the dredge equipment or site characteristics, the user can find an accurate cost estimation using the CSDCEP.

## CUTTER SUCTION DREDGE

The cutter suction dredge is the most versatile, and most common type of dredge, having the major advantage of being able to move dredged material hydraulically to a placement area without the need to re-handle the sediment. Typically, a cutter suction dredge consists of a pipeline, cutter, ladder pump (if necessary), spuds, winches, and the main cabin which houses the dredge pump and crew facilities. A typical cutter suction dredge is illustrated in Figure 1. There are many sizes of cutter suction dredges, the size of the dredge is determined by the diameter of the discharge pipeline (Randall 2017). The floating discharge pipeline is connected to the stern swivel on the dredge. A ladder supports the suction pipe, cutter, and lubricating lines. The ladder is supported on deck and consists of hoisting equipment to raise or lower the ladder.

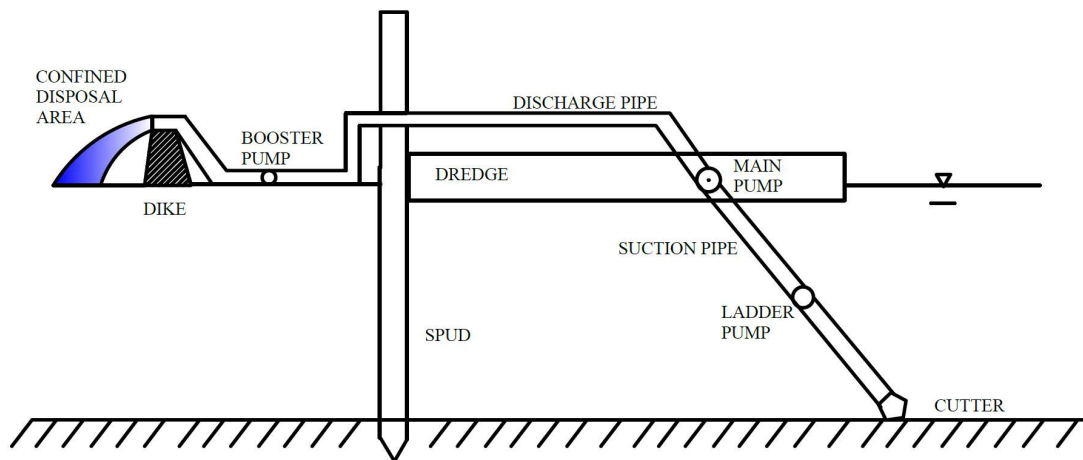

**Figure 1: Typical Cutter Suction Dredge and Components**

During dredging, the cutter loosens and excavates sediment that then gets transported into the suction pipeline. A centrifugal pump allows hydrostatic pressure to force both the sediment and water through the suction pipe. The water sediment mixture or slurry is then moved through the discharge pipe using a main pump and possibly booster pumps to the placement site. The discharge line consists of three sections, the pipeline on the dredge, the floating or submerged pipeline, and the pipeline on shore. The length of the pipelines and slurry characteristics determine if additional pumps or booster stations along the pipeline are needed. Pipelines can be set up for discharge to an upland site, beneficial use (such as a beach nourishment project), or to barges that are towed out to sea to an approved placement area in the open water. There are two common types of cutter suction dredges advancement methods, the spud carriage advancement, and the fixed spud advancement. Fixed spud dredges can only excavate material half the time for a dredge efficiency of 50%, while the spud carriage increases the dredge efficiency to 75% (Randall 2017).

The spuds allow the dredge to advance in steps of one cutter head length into the dredging face. In each position, the dredge is swung from side to side and completes an almost continuous operation. The speed of the cutter depends on the material being dredged, the dredging depth, and the size of the dredge. In order for the dredge to discharge at a different location, the pump must be stopped. The operating cycle of the cutter suction dredge is to cut, advance on spuds, cut, advance on spuds and repeat. Spuds are used as an anchor point around which the cutter swings. At the end of the swing, the dredge needs to move forward to begin the next cut. For the fixed spud system, the spuds are fixed to the aft end of the dredge. The spuds can only move up

and down as the spuds are raised from or lowered into the seabed. A fixed spud dredge has a working spud and an auxiliary spud. The working spud is on the centerline of the seabed being dredged. When the cutter reaches the end of the swing and is ready to advance, the dredge returns to the step angle (approximately 10 degrees off the centerline), the auxiliary spud is lowered and the working spud is raised, then the dredge swings around the auxiliary spud to its step angle on the opposite side of centerline. At this point the working spud is lowered to the seabed and the auxiliary spud is raised. The dredge continues working until it must advance again, and the steps are repeated. The fixed spud dredge system is not as efficient as the spud carriage, since a fixed spud advancing system only excavates material about 50% of the time, as the cutter must swing over areas that have already been dredged.

The spud carriage system is more efficient than the fixed spud system. A spud carriage enables the dredge to move forward on the working spud without the need to frequently raise and lower the spud. The only time the work spud needs to be repositioned is when the spud carriage is fully extended, then the auxiliary spud is lowered to the seabed, and the working spud is raised out of the seabed. The working spud on the carriage is repositioned to the front of the carriage slot using hydraulic power. Figure 2 shows the method of advancing for a cutter suction dredge with fixed spuds and with a spud carriage.



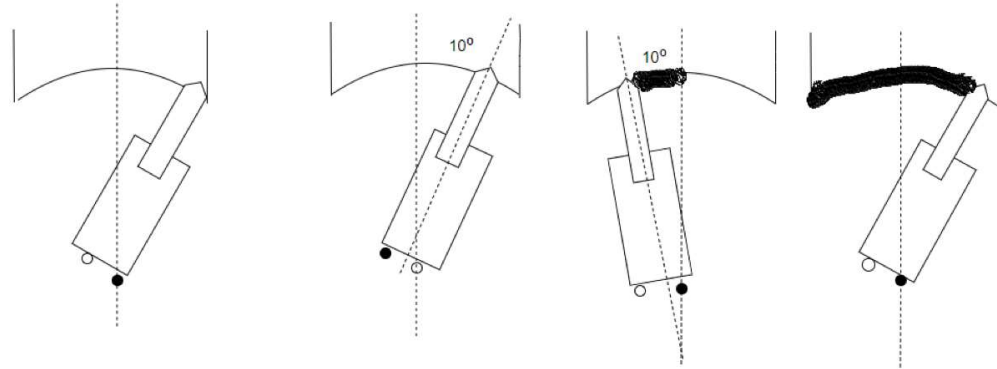

Cutter Suction Dredge with Fixed Spuds

Black = Spud lowered  
White = Spud raised

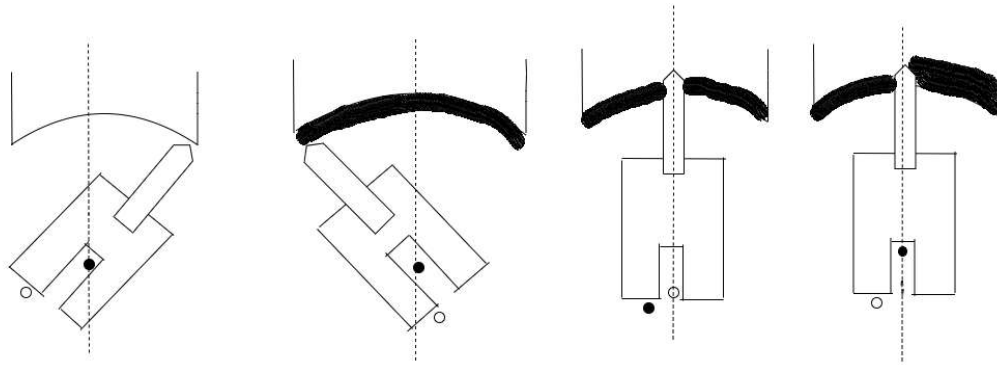

Black = Spud lowered  
White = Spud raised

Cutter Suction Dredge with Spud Carriage

**Figure 2: Cutter Suction Dredge: Method of Advancing**

## REVIEW OF LITERATURE

Since commercial dredging began, extensive academic research and work has been conducted to develop a reliable, publicly available production and cost estimating procedure for dredging projects. Any review of prior research on cost estimating and hydraulic transport fundamentals points to the same conclusion: accurate production rates are critical in determining accurate cost estimates.

A production estimate determines how much time a dredging project will take to be completed. It also leads to the final cost because, the longer a job takes the higher the final cost. Turner (1996) states that production for hydraulic dredges is simply the quantity of solids transported.

Therefore, the average flow rate of the slurry times the average percent solids is the simplest form of the production equation. If the flowrate (gallons per minute, cubic meters per second), and the average percent solids are both known then the production rate can be calculated. Turner (1996) also describes the importance of the bank factor in the production estimate for cutter suction dredges. The bank factor is the ratio of work face (bank height) to cutter diameter that the cutter is excavating on the sea floor. The bank factor impacts the dredge efficiency, which in turn affects production.

Bray et al. (1997) also discusses the importance of production to the final cost estimate. Bray defines production as output, or the rate at which a dredge moves an in-situ quantity of soil in a

given period. The varying bank heights cause different levels of efficiency, depending on the material being dredged, as well as the cutterhead's size.

According to Randall (2017), the best way to find the optimal flow rate to determine production is by comparing the pump characteristics curve and the system head curve. Pump characteristics curves graph the total head, power, and efficiency as a function of the flow rate of water. The system head curve is found using the modified Bernoulli or energy equation. The intersection of the system head curve and the pump head curve is the operating point, and the point at which the optimal flow rate is found.

Wilson et al. (2006) offers a way to calculate losses for slurry moving through a pipeline. Slurry is the mixture of solid particles in a fluid that is carrying it, most often water. There are three types of slurry flow that Wilson et al. (2006) discusses, large rapidly-settling particles which create a fixed bed, fine grained particles that are distributed evenly in the fluid, homogeneous flow, or a mixture of both, heterogeneous flow.

Miertschin (1997) developed the first Cutter Suction Dredge Cost Estimating Program for the Center for Dredging Studies at Texas A&M University in 1997. The same method influenced all future dredging estimation programs developed at Texas A&M, including programs for hopper dredges, and mechanical dredges with the same program function. When pump information is unknown the Cutter Suction Dredge Cost Estimating Program uses dimensionless pump characteristics curves to estimate specific pump characteristics curves. This ensures the cost estimating program is able to work for different sizes dredges no matter if specific pump

information is known. Non-dimensional pump characteristics created production estimation flexibility by calculating the non-dimensional pump head, power, and efficiency across all pump speeds and sizes. A specific pump characteristics curve is not needed but can be added by the user for more accurate results.

Belesimo (2000) updated the cost estimating program for the cutter suction dredge created by Miertschin and added hopper dredge estimates. In addition to including the new calculations for hopper dredges, Belesimo focused on large cutter suction dredges of 68.6 centimeters (27 inches) and larger and created more customization from Miertschin's previous version. Belesimo's 2010 cost estimating program achieved an average difference of 17.3% from the winning bid to the cost estimating program, as compared to the 16.2% difference between the government estimate and the winning bid from the dredging projects that were chosen for the comparisons.

Auger (2012) developed the most recent update to Miertschin's initial cutter suction dredge cost estimation program in 2012. Auger used Miertschin's previous work and added the Matousek (1997) equation to calculate critical velocity, determined ladder pump requirements, applied regional indices, and updated cost information. Auger's cost estimating program improved Miertschin's results with an average difference from the winning bid to the estimate of 18% as compared with the 19% difference between the winning bid and the government estimate.

The Center for Dredging Studies at Texas A&M has been updating and adding new aspects to the dredge cost estimating program for over twenty years. In addition to the cutter suction

dredge, the hopper and mechanical dredge cost estimates are also calculated in the Combined Cost Estimating Program. Adair (2006) added mechanical dredges in 2006 and Papis (2017) updated the program in 2017. After Belesimo added the hopper dredges in 2000, Hollinberger (2010) updated the hopper dredge cost estimating program and Wowtschuk (2016) describes the most recent update to hopper dredges in 2016.

## METHODOLOGY FOR ESTIMATING PRODUCTION

As previously stated, the production rate is the most important factor in determining an accurate cost estimate. Bray et al. (1997) defines the production rate as the amount of material moved per unit of time. Once the production rate is known then the amount of time for a project can be calculated. The longer a project takes the more it will cost, and the more resources used. In order to determine an accurate cost estimate, an accurate production rate must first be found.

### Hydraulic Transport

The transportation of solid material suspended in liquid, or hydraulic transport, is the basis behind cutter suction dredging. For the dredged material to be pumped long distances, the main pump might not have enough power or “head” to transport the slurry to the disposal site. The total pump head ( $H_p$ ) is the difference between the discharge head ( $H_2$ ) and the suction head ( $H_1$ ).

$$H_p = H_2 - H_1 \quad (1)$$

$$H_1 = \frac{P_1}{\gamma} + \frac{V_1^2}{2g} + z_1 \quad (2)$$

$$H_2 = \frac{P_2}{\gamma} + \frac{V_2^2}{2g} + z_2 \quad (3)$$

These equations are derived from Bernoulli's equation and assume steady flow, incompressible fluid, and a frictionless pipe. The symbol  $P$  is the pressure in the pipe,  $\gamma$  is the specific weight of the slurry,  $V$  is the mean velocity in the pipe,  $g$  is acceleration due to gravity, and  $z$  is the elevation of the centerline of the pipe with respect to the centerline of the pump. The subscripts 1 and 2 are for the discharge and suction ends of the pipes, respectively, as shown in Figure 3. Pipes in the real world are not frictionless and friction losses are added with an additional head loss term which will be discussed. The energy equation is a modified version of Bernoulli's equation that combines Equations (2) and (3) and including the friction losses,  $H_f$  and minor losses,  $H_m$  (Kondu, et al. 2016).

$$\frac{P_1}{\gamma} + \frac{V_1^2}{2g} + z_1 + H_p = \frac{P_2}{\gamma} + \frac{V_2^2}{2g} + z_2 + H_f + H_m \quad (4)$$

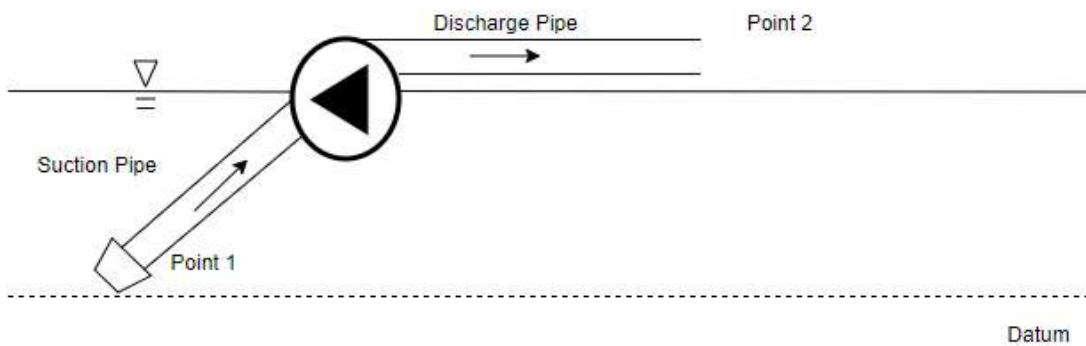
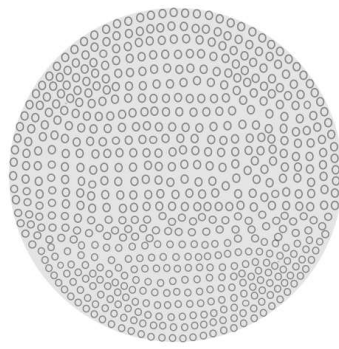

**Figure 3: Schematic of Reference Points 1 and 2**

Centrifugal dredge pumps introduce energy into the hydraulic transport system by increasing the velocity of the slurry inside the pump. The volume of an incompressible fluid into the pump must equal the volume exiting the pump, according to the law of continuity. As the fluid leaves the pump to a pipeline, which has the same diameter as the inlet pipeline, the discharge velocity must approach the inlet velocity (Jin and Randall 2018). According to Bernoulli's Law, as velocity increases there is a simultaneous decrease in pressure or a decrease in the slurry's potential energy, or vice versa, if the elevation and diameter remain the same. Using this principle, the pressure, or head of the dredging hydraulic transport system can be increased.

Wilson et al. (2006) discusses three types of flow regimes and sediment distribution in pipelines. The flow varies depending on the type of sediment and type of fluid. The first is when the sediment particles are supported by the sides and bottom of the pipe that creates a fixed bed and results in large friction losses. On the other side of the spectrum sediment particles are evenly distributed over the pipe diameter due to high velocity and turbulence and is called homogeneous flow. The final type of flow is in between the fixed bed and homogeneous flow and is called heterogeneous flow. For this case the sediment particles are supported by water, friction losses are reduced, and less power is needed. In heterogeneous and homogeneous flow, the sediment travels at the same velocity as the fluid. Figure 4 shows the distribution of sediment in homogeneous flow, heterogeneous flow, and a fixed bed.





Homogeneous Flow

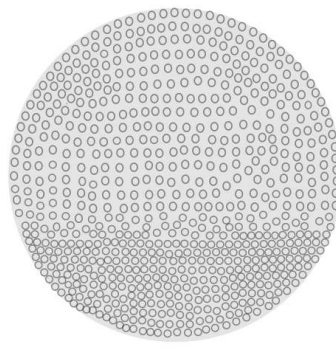

Heterogeneous Flow

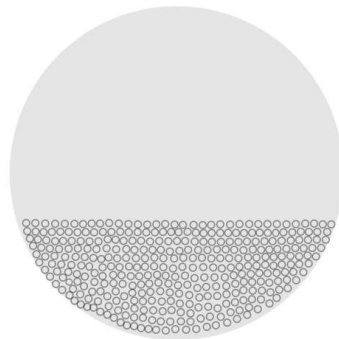

Fixed Bed

**Figure 4: Sediment Distribution in a Pipeline**

In heterogeneous flow, the sediment is just supported by the water and is the ideal sediment distribution for dredging. If the dredging slurry consists of homogeneous flow, more energy is required since a higher velocity is needed to pump the slurry, due to the distribution of particles. With the higher velocity there is also an increase in losses and wear in the pipeline, which leads to higher costs. The fixed bed slurry flow is the least desirable slurry flow as the sediment is stationary on the bottom of the pipe and can lead to plugging or clogging of the pipeline. The velocity changes for each slurry flow, as a higher velocity is needed for homogeneous, and the

lowest velocity for fixed bed flows. The settling velocity ( $v_t$ ) is calculated using Schiller's (1992) equation

$$v_t = 134.14(d_{50} - 0.039)^{0.972} \quad (5)$$

where  $v_t$  is the settling velocity in mm/s and  $d_{50}$  is the median grain diameter in mm. This equation is used in the cost estimating program and is widely used due to its simplicity.

Schiller's equation only requires the knowledge of the median grain size ( $d_{50}$ ) in millimeters.

There are four equations, in addition to Schiller's (1992) equation, that Miedema (2016) discusses to calculate the settling or terminal velocity of sediment particles. Most of the equations used for calculating settling velocity derive the equations empirically. The particle size, density, shape, and fluid properties are all important factors when developing the empirical equations. The equations most commonly used are by Schiller (1992), Cheng (1997), Swamee and Ojha (1991), Wilson et al. (2006), and Hartman et al. (1994).

Cheng (1997) developed an empirical relationship for settling velocity of non-spherical particles based on the data by Schiller and Naumann (1933). The equation developed by Cheng is only valid for natural sand. The formula is as follows:

$$v_t = \frac{v}{d} \left[ \sqrt{25 + 1.2d_*^2} - 5 \right]^{1.5} \quad (6)$$

where

$$d_* = \left[ \frac{(\rho_s - \rho_f)g}{\rho_f v^2} \right]^{\frac{1}{3}} d_{50} \quad (7)$$

$\rho_s$  and  $\rho_f$  are the density of solids and fluids respectively,  $g$  is the acceleration of gravity,  $d_{50}$  is the median grain size, and  $v$  is the kinematic viscosity of the fluid.

Swamee and Ojha (1991) derived an empirical equation for the settling or terminal velocity of non-spherical particles. This equation is valid for a wide range of particle grain sizes, and for any specific gravity. The equation is as follows:

$$w_* = \left[ \frac{44.84v_*^{0.667}}{(1 + 4.5\beta^{0.35})^{0.833}} + \frac{0.794}{(\beta^4 + 20\beta^{20} + v_*^{2.4}e^{18.6\beta^{0.4}})^{0.125}} \right]^{-1} \quad (8)$$

with the non-dimensional parameters of:

$$w_* = \frac{v_t}{\sqrt{(SG_s - 1)gd_n}} \quad (9)$$

$$v_* = \frac{v}{d_n\sqrt{(SG_s - 1)gd_n}} \quad (10)$$

where  $g$  is the acceleration of gravity,  $SG_s$  is the specific gravity of solids,  $d_n$  is the nominal grain diameter, and  $\beta$  is the Corey shape factor defined respectively as:

$$d_n = \left(\frac{6V}{\pi}\right)^{\frac{1}{3}} \quad (11)$$

$$\beta = \frac{c}{\sqrt{ab}} \quad (12)$$

The Corey shape factor is the ratio of the shortest particle axis,  $c$ , to the square root of the product of the other two axes,  $a$  and  $b$ .

Wilson et al. (2006) calculated the settling velocity for a sphere in water. This equation is more complicated, but is valid for any grain size or specific gravity.

$$v_{ts}^* = d_{50} \left[ \frac{\rho_f (\rho_s - \rho_f) g}{\mu^2} \right]^{\frac{1}{3}} \quad (13)$$

$$v_{tf} = \left[ \frac{\rho_f^2}{(\rho_s - \rho_f) g \mu} \right]^{\frac{1}{3}} \quad (14)$$

$$v_{ts} = \frac{v_{ts}^*}{v_{tf}} \quad (15)$$

$$v_t = \zeta v_{ts} \quad (16)$$

The term  $\zeta$  is the velocity ratio and obtained from the chart created by Wilson et al. (2006),  $\rho_s$  and  $\rho_f$  are the density of the solids and fluids respectively,  $d_{50}$  is the median grain size,  $\mu$  is the coefficient of friction, and  $g$  is the acceleration of gravity.

Hartman et al. (1994) used more than 400 experiments conducted on limestone to determine shape factors for different size particles. This equation is the most complicated to calculate but is valid for all grain sizes and specific gravities. To determine the shape factor for the Hartman et al. (1994) equation the sphericity shape factor  $\psi$  is used.

$$\psi = \frac{A_{sphere}}{A_{particle}} \quad (17)$$

The relationship for Reynolds number (Re) is also given as:

$$\log_{Re}(A_r, \varphi) = \log_{Re}(A_r, 1) + P(A_r, \varphi) \quad (18)$$

$$v_t = \frac{v d_{50}}{Re} \quad (19)$$

$$\begin{aligned} \log_{Re}(A_r, 1) = & -1.2738 + 1.04186 \log A_r - 0.060409(\log A_r)^2 \\ & + 0.0020226(\log A_r)^3 \end{aligned} \quad (20)$$

$$\begin{aligned} P(A_r, \varphi) = & -0.071876(1 - \varphi) \log A_r - 0.023093(1 - \psi)(\log A_r)^2 \\ & + 0.0011615(1 - \varphi)(\log A_r)^3 + 0.075772(1 - \varphi)(\log A_r)^4 \end{aligned} \quad (21)$$

$$A_r = d_{50}^3 g \frac{\rho_f (\rho_s - \rho_f)}{\mu_f^2} \quad (22)$$

where  $d_{50}$  is the median grain size,  $\rho_s$  and  $\rho_f$  are the density of the solids and fluids respectively,  $\mu_f$  is the coefficient of friction, and  $g$  is the acceleration of gravity.

### Critical Velocity

As the sediment travels through the pipeline the fluid must maintain a critical velocity to prevent the sediment from falling to the bottom of the pipe. Critical velocity is the velocity at which a particle falls from suspension and causes deposits in the pipeline. If the sediment does not reach the critical velocity then the pipeline can become clogged, due to the particles falling. This can cost time and effort to unblock. Therefore, critical velocity must be maintained. Critical velocity is a function of the specific gravity of the sediment, the grain size, and the inside pipe diameter. Most dredging projects try to maintain an average velocity 10% above the critical velocity. A higher velocity lessens pipeline wear, head losses, and power requirements. Wilson, et al. (2006) developed a method to determine the critical velocity using a nomograph, as shown in Figure 5, and Matousek (1997) developed an equation using a curve fit for Wilson's nomograph as:

$$V_c = \frac{8.8 \left[ \frac{\mu_s (S_s - S_f)}{0.66} \right]^{0.55} D^{0.7} d_{50}^{1.75}}{d_{50}^2 + 0.11D^{0.7}} \quad (23)$$

where  $\mu_s$  is the coefficient of mechanical friction between the solid particles, and the pipe wall, usually equal to 0.44,  $S_s$  is the specific gravity of solids,  $S_f$  is the specific gravity of fluid,  $d_{50}$  is the median grain diameter (mm), and  $D$  is the inside pipe diameter (m). The Matousek equation for critical velocity is used in the Cutter Suction Dredge Cost Estimating Program.

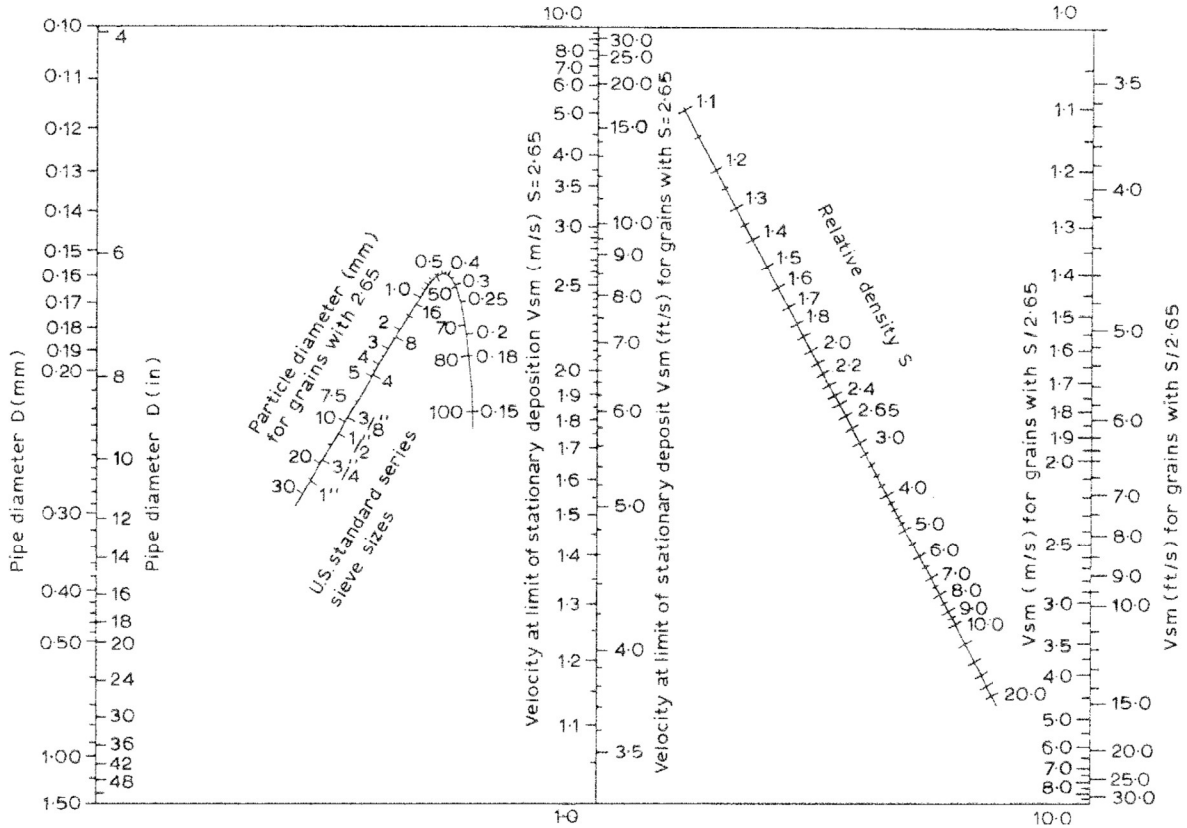
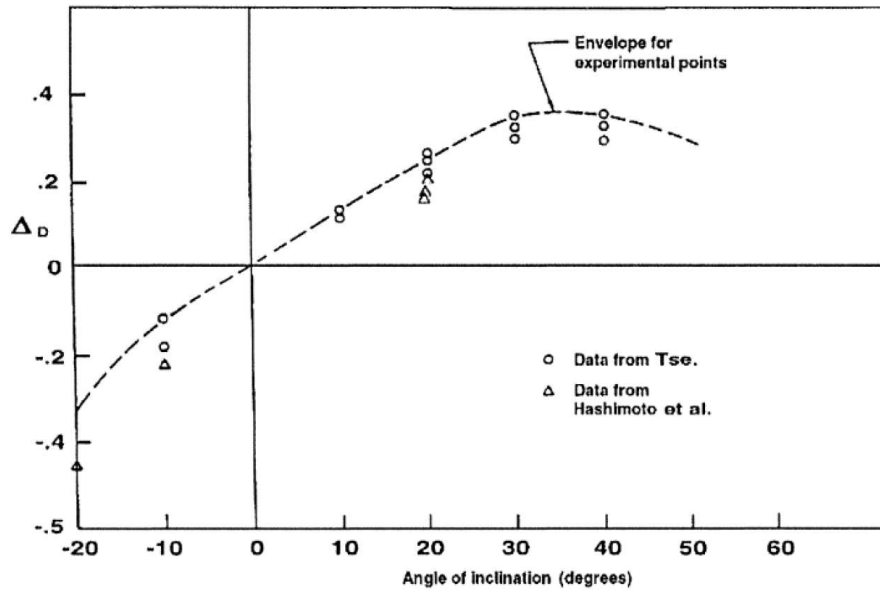

**Figure 5: Nomograph for Estimating Critical Velocity in Slurry Pipelines (Wilson et al. 2006)**

When the pipeline is inclined, the critical velocity increases. This effect of pipe inclination on critical velocity was studied by Wilson & Tse (1984) to show that the critical velocity increases as the angle between the pipe and horizontal increases up to an angle of 35 degrees. This increase needs to be taken into consideration using the following equation:

$$V_c(\text{inclined}) = V_c(\text{horizontal}) + \Delta_D(\sqrt{2g(SG_S - 1)D}) \quad (24)$$

where  $\Delta_D$  is found from Figure 6 as a function of the angle of inclination (degrees).



**Figure 6: Effect of Angle of Inclination on the Critical Velocity (Wilson & Tse, 1984)**

Slurry transport in pipelines is also classified between settling and nonsettling. If the slurry consists of mostly sands, the sand settles to the bottom of the pipeline, then the slurry is a settling flow. When the sediment is silts and clays, the slurry is considered a nonsettling flow. Most dredging projects consist of sands, silts, and clays, and the flow is considered as settling due to the presence of sand. Both settling and non-settling flows involve energy losses. The critical and settling velocity are used in the determination of the frictional losses inside the pipeline.



## System Head Losses

The first step to finding the production is to determine the optimal flow rate, Q. To determine Q, the pump characteristics curve and the system head curve are plotted, and the intersection point is found (Randall 2017).

The system head curve must first be determined by estimating the system head losses. These head losses are broken into minor losses,  $h_m$ , and frictional or major losses,  $h_f$ . The minor losses result from fittings and joints in the piping system and is estimated with the minor loss coefficient (K) and the equation:

$$h_m = \sum K \frac{V^2}{2g} \quad (25)$$

with K as the minor loss coefficient, V is velocity, and g is the acceleration of gravity. The frictional losses in a piping system are dependent on the length of pipe, diameter of pipe, transport velocity, and the properties of the sediment being transported. Wilson et al. (2006) provides a method for determining frictional losses in a slurry flow applicable to hydraulic dredges, using the following equation:

$$\text{Pipe head loss} = i_m \times \text{length of pipe} \quad (26)$$

where  $i_m$  is the head loss due to friction per unit length of pipe. To calculate  $i_m$  the Matousek equation, Equation (23), is used to find the critical velocity in the equation for  $i_m$  developed by Wilson et al. (2006):

$$i_m = \frac{fV^2}{2gD} + 0.22(SG_s - 1)V_{50}^{1.7}C_vV^{-1.7} \quad (27)$$

$$V_{50} = w \sqrt{\frac{8}{f}} \cosh \left[ \frac{60d}{D} \right] \quad (28)$$

$$w = 0.9v_t + 2.7 \left[ \frac{(\rho_s - \rho_f)g\mu}{\rho_f^2} \right]^{\frac{1}{3}} \quad (29)$$

where  $f$  is the friction factor,  $V$  is the average velocity in the pipeline,  $g$  is the acceleration of gravity,  $D$  is the pipe inside diameter,  $SG_s$  is the specific gravity of the solids,  $V_{50}$  is the fluid velocity at which 50% of the solids are suspended,  $C_v$  is the delivered concentration by volume,  $d$  is the medium particle diameter,  $\rho_s$  and  $\rho_f$  are the density of the solid and the fluid, respectively,  $\mu$  is the dynamic viscosity of the fluid, and  $v_t$  is the particle settling velocity. The total losses are the combination of the minor and major losses. The Wilson equations are used to determine major losses in the Cutter Suction Dredge Cost Estimating Program.

Table 1 contains common minor loss coefficients (K) values found on cutter suction dredges based on Randall (2017). The total minor loss coefficient (K) is found by summing all of the K values and using that number in Equation (25).

**Table 1: Minor Loss Coefficients (K) for Common Dredge Components**

| <b>Component</b>        | <b>K</b> |
|-------------------------|----------|
| <u>Suction Entrance</u> |          |
| Plain end suction       | 1.0      |
| Rounded suction         | 0.05     |
| <u>Elbows</u>           |          |
| Long radius suction     | 0.6      |
| 45° elbows              | 0.3      |
| 90° elbows              | 0.9      |
| Stern swivel            | 1.9      |
| <u>Ball joints</u>      |          |
| Straight                | 0.1      |
| Medium cocked           | 0.4-0.6  |
| Fully cocked            | 0.9      |
| Discharge               | 0.5      |

When calculating friction loss, the assumption that the flow is horizontal is made. If the flow has any incline then the friction loss changes and needs to be calculated using additional equations from Wilson et al. (2006).

$$\Delta i(\theta) = \Delta i(0) \cos \theta + (SG_s - 1)C_v \sin \theta \quad (30)$$

$$\Delta i(0) = i_m - i_w \quad (31)$$

where  $i_w$  is the head loss of water per meter/foot of pipe for water,  $i_m$  is the head loss of water per meter/foot of pipe for the mixture,  $C_v$  is the concentration by volume,  $SG_s$  is the specific gravity

of the solids, and  $\theta$  is the angle of inclination measured from the horizontal. The length of horizontal pipe and the friction loss is added to the friction loss occurring at the incline pipeline. The final results are the total loss due to friction in the pipeline.

If the main pump head is less than five percent greater than the head losses, then a booster pump is added to the system. With the addition of the booster pump to the discharge line, the booster pump's head is added to the main pump's head. Additional booster pumps are added until the total system head is greater than the head losses, and the slurry can be transported through the pipeline.

### **Friction Factor**

The friction factor is a dimensionless factor which relates the friction of a pipe. It depends on the characteristics of the pipe, diameter, roughness, the characteristics of the fluid, and the Reynolds number. The friction factor ( $f$ ) is a function of Reynolds number ( $Re$ ) and the relative roughness ( $\epsilon/D$ ). There are many equations and methods to find the friction factor. The most well-known method is from the Moody diagram, developed by Moody in 1944. The Colebrook-White equation (1937) is also used extensively, but this equation cannot be solved directly since the friction factor ( $f$ ) appears on both sides of the equation. The Colebrook-White equation is below:

$$\frac{1}{\sqrt{f}} = -2 \log_{10} \left[ \frac{(\epsilon/D)}{3.7} + \frac{2.51}{Re\sqrt{f}} \right] \quad (32)$$

where  $\varepsilon/D$  is the relative roughness,  $f$  is the friction factor, and  $Re$  is the Reynolds number.

Using the Colebrook-White equation, Swamee and Jain developed another equation to solve for the friction factor directly in 1976. The Swamee and Jain (1976) equation is as follows:

$$f = \frac{0.25}{\left[ \log \left( \frac{\varepsilon}{3.7D} + \frac{5.74}{Re^{0.9}} \right) \right]^2} \quad (33)$$

This equation is valid for a range of Reynolds numbers and relative roughness between  $5 \times 10^{-3} \leq Re \leq 10^8$  and  $10^{-6} \leq \frac{\varepsilon}{D} \leq 10^{-2}$ .  $\varepsilon$  is the pipe surface absolute roughness (millimeters) and  $Re$  is the Reynolds number.

$$Re = \frac{\rho_f V D}{\mu} = \frac{V D}{\nu} \quad (34)$$

where  $\nu$  is the kinematic viscosity,  $L$  is the length of pipe, and  $D$  is the inside pipe diameter. The friction factor can also be determined using the Moody diagram (1944) which is a non-dimensional chart that relates the friction factor, relative roughness, and the Reynolds number.

Moody also developed a relationship from the chart that is valid for all ranges of Reynolds numbers and relative roughness.

$$f = 5.5 \times 10^{-3} \left[ 1 + \left( 2 \times 10^4 \left( \frac{\varepsilon}{D} \right) + \frac{10^6}{Re} \right)^{\frac{1}{3}} \right] \quad (35)$$

The cost estimating program uses the Swamee and Jain (1976) equation to find the friction factor. Herbich (2000) and Randall (2000) state that the Swamee and Jain (1976) equation is a comparative substitute for Colebrook-White (1937) and Moody (1944). The relative error between the Moody and Swamee and Jain equations compared to the Colebrook-White equation was calculated using the following equation.

$$Relative\ error = \frac{(f_{Colebrook-White} - f_{Swamee})}{f_{Colebrook-White}} \times 100 \quad (36)$$

This same equation is used to compare the Colebrook-White equation to Moody. Asker et al. (2014) conducted a review of many friction factor equations including Colebrook-White, Swamee and Jain, and Moody. Using a relative roughness  $\epsilon/D$  of .001 for comparison, the percent average deviation from Moody to Colebrook-White is 6.56% and the percent average deviation from Swamee and Jain to Colebrook-White is 4.44%. The percent standard deviation was calculated as 3.29% and 0.66% for Moody and Swamee compared to Colebrook-White respectively. These results are relatively close, and the differences will not affect the results of the cost estimating program.

The friction factor is used in Equation (27) to determine the major losses for the Cutter Suction Dredge Cost Estimating Program. To find the friction factor, the roughness or the relative roughness must be known. The default setting for the roughness in the program is set for a commercial steel pipe, which has a roughness of 0.00015 feet. The user can change the absolute

roughness number if a different material of pipe is used for the dredging project. Table 2 shows a few common pipe materials with the value of their absolute roughness,  $\epsilon$ .

**Table 2: Values of Absolute Roughness  $\epsilon$  for Pipes**

| Type of Pipe                     | $\epsilon$ : Absolute Roughness of Surface (ft) | $\epsilon$ : Absolute Roughness of Surface (mm) |
|----------------------------------|---|---|
| Smooth                           | 0   | 0   |
| High-Density Polyethylene (HDPE) | 0.000005  | 0.001524  |
| Commercial Steel                 | 0.00015   | 0.04572   |
| Concrete                         | 0.001-0.01                                      | 0.3048-3.048                                    |
| Riveted Steel                    | 0.003-0.03                                      | 0.9144-9.144                                    |

Dredges are starting to use more high-density polyethylene (HDPE) pipe. HDPE pipe is made from a thermoplastic polymer produced from ethylene. HDPE is lightweight, flexible, and easy to install. Depending on the application, HDPE pipe has a large strength to density ratio and can be used in many fields. HDPE is used in the production of plastic bottles, plastic lumber, and corrosion-resistant piping. The high abrasion resistant HDPE pipe has a lower roughness than steel and creates less friction causing less friction losses (Barfuss and Tullis, 1988). But as slurry passes through steel the abrasion can create a smoother surface, creating less friction as time

increases. There is no one answer for which material is better in terms of roughness, there are pros and cons for each pipe material. HDPE pipes are easy to transport and install due to their lightweight and flexibility. HDPE is produced in many sizes of inside pipe diameters and depending on the dredging project, using a larger pipe can increase production and efficiency. Most of the HDPE pipe made is also lighter than water, which lends to towing using smaller tugs, or requires less floatation during a project if a floating pipeline is needed. With a high resistance to corrosion, HDPE piping has a lifespan of 50-100 years, but can also be more prone to cracking, and cannot stand high heat or pressure. Certain dredging projects which include the need to dredge sharper material would not be suited for HDPE piping because of the predisposition of the HDPE pipe to tears or leaks. Steel pipe is reliable, strong, durable and is also resistant to corrosion. Steel pipes come in lengths from 6 meters to 20 meters or 20 feet to 65 feet lengths. HDPE pipes can also be purchased in the same length sizes. The type of pipe material should be chosen for each specific dredge project. HDPE piping can be an efficient alternative or supplement to steel discharge piping, depending on the dredging conditions. Figure 7 shows a picture of high-density polyethylene pipe. Figure 8 shows a picture of steel pipe.





**Figure 7: Picture of HDPE Piping (Performance Pipe 2018)**



**Figure 8: Picture of Steel Piping (HI-SEA Marine 2018)**

## Dimensionless Pump Characteristics Curves

The pump characteristics curve depends on the type, location, and quantity of pumps used.

Pump information for various dredging pumps can be provided by the manufacturer and can be input directly into the software by the user. There is also an option to use dimensionless pump curves if the specific pump information is not known. Many users or government agencies may not know the specific pumps being used or may not have the pump curves that the project needs. In order for the program to work without a specific pump, a dimensionless pump curve is available in the spreadsheet. These dimensionless values are determined using the following dimensionless equations and used to create the dimensionless pump curve.

Dimensionless horsepower:

$$P_{dim} = \frac{P}{\rho \omega^3 D^5} \quad (37)$$

Dimensionless flowrate:

$$Q_{dim} = \frac{Q}{\omega D^3} \quad (38)$$

Dimensionless head:

$$H_{dim} = \frac{gH}{\omega^2 D^2} \quad (39)$$

where P is horsepower,  $\rho$  is the fluid density, D is the impeller diameter, Q is the flowrate, H is the head, g is acceleration due to gravity, and  $\omega$  is the angular velocity or speed. The dimensionless curves used in the cost estimating program were developed from six dimensional curves by GIW Industries Inc. Industry is consistently improving and updating pump

manufacturing and producing pumps that can generate more head. The last update in the Cutter Suction Dredge Cost Estimating Program for the non-dimensional pump curves was in 1997 by Miertschin (1997). Current pump characteristics curves from GIW Industries were used to update the non-dimensional pump characteristics curve in the Cutter Suction Dredge Cost Estimating Program. Two nondimensionalized pump characteristics are included in the cost estimating spreadsheets from a GIW 12-inch x 14-inch dredge pump and a 24-inch x 24-inch dredge pump. Depending on the size of dredge the user selects, the nondimensionalized pump curve that fits the dredge size best is automatically chosen, unless the user opts to input pump characteristics manually for a specific pump. The pump characteristics curve for a 24-inch suction and 24-inch discharge centrifugal pump with a 64-inch impeller manufactured by GIW Industries Inc. (GIW 2003) is shown in Figure 9.

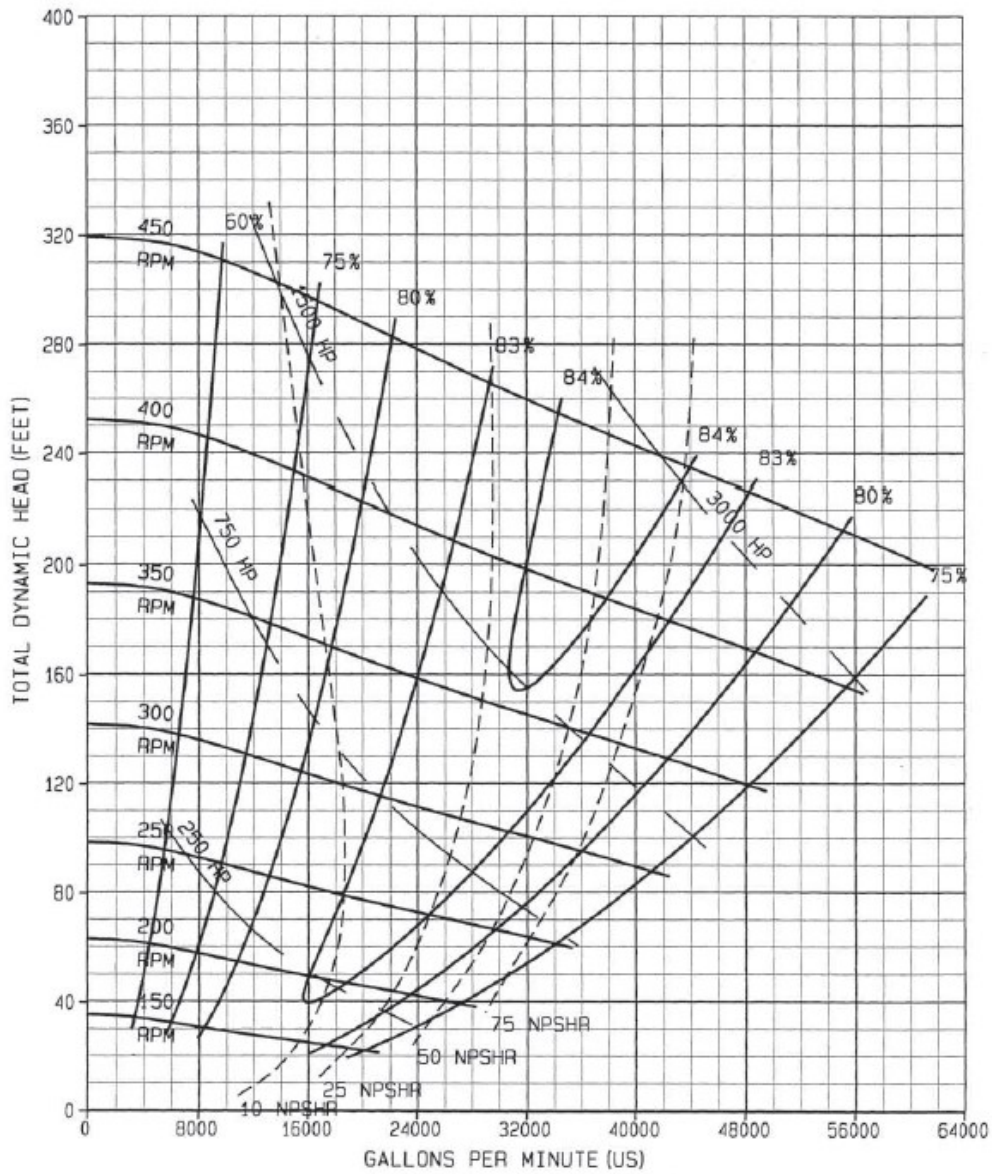

**Figure 9: Pump Characteristics Curve (GIW Industries, 2003)**

The pump head curve is plotted along with the system head curve, calculated by Equations (4), (25), and (26), as a function of flowrate. Figure 10 shows the system head curve and the pump head curve plotted together. The optimal flowrate, or the point where the system head curve and

the pump head curve intersect is the flowrate used in the Cutter Suction Dredge Cost Estimating Program. Figure 10 also shows the critical flowrate,  $Q_c$ , the optimal flowrate must be greater than the critical flowrate.

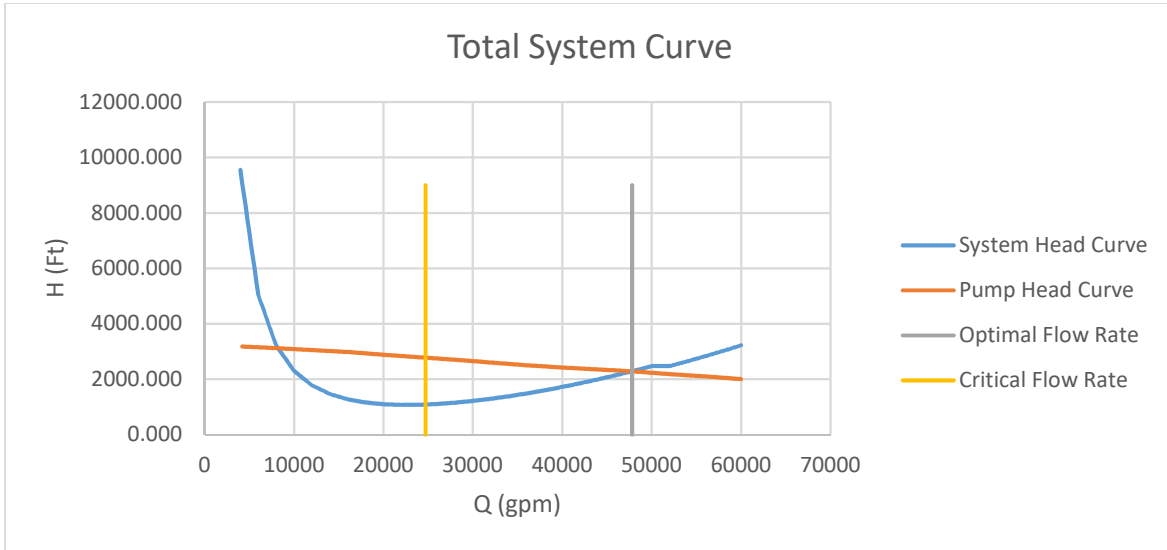

**Figure 10: Example of System Head Curve Superimposed on Pump Head Curve**

### Total Production Rate

The operating point, or the intersection of the pump head curve and the system head curve will be used for the flow rate,  $Q$ , in GPM as shown in Figure 10. The production rate of a dredge is defined by Bray et al. (1997) as the amount of material moved per unit of time. After the production rate is found, the length of time to complete the dredging project can be determined, using the cubic volume of the dredged material from a specific project. For cutter suction dredges the material is removed from the sea floor with an induced water flow created by a

centrifugal pump. Turner (1996) developed an equation to estimate the production of a pipeline dredge as:

$$P = AQ C_{v\ ave} \quad (40)$$

$$P = AQ C_{v\ max} DE \quad (41)$$

where A is a conversion factor of 0.222 in SI units (m<sup>3</sup>/hr) and 0.297 in English units (cy/hr), P is the production (cy/hr), Q is the average flow rate (GPM),  $C_{v\ ave}$  is the average delivered concentration of solids by volume,  $C_{v\ max}$  is the maximum delivered concentration of solids by volume, and DE is the dredging efficiency. The dredging efficiency is 50% when using fixed spuds or 75% when using a spud carriage advancement. Production can be estimated using Equations (40) and (41). Either production equation can be used in the spreadsheet with the user choosing to input either  $C_{v\ avg}$  or  $C_{v\ max}$  depending on the information available.

The concentration of solids by volume,  $C_v$ , is the ratio of solids to the total amount of water and sediment mixture, known as slurry, expressed as:

$$C_v = \frac{SG_m - SG_f}{SG_s - SG_f} \quad (42)$$

where  $SG_m$  is the specific gravity of the mixture,  $SG_f$  is the specific gravity of fluid with water normally equaling 1.0, and  $SG_s$  is the specific gravity of the solids or in-situ specific gravity of material dredged (Turner 1996).

The spreadsheet determines if a ladder pump is required. A ladder pump is an additional pump located in the suction line of the dredge. If cavitation occurs in the pump then a ladder pump is needed. Cavitation is the formation and collapse of low-pressure cavities in a flowing liquid and can cause serious damage or failure to pumps. To determine if cavitation is present, the net positive suction head (NPSH) is calculated. By comparing the available NPSH to the required NPSH it can be determined if cavitation occurs or not. If the available NPSH is greater than the required NPSH then the pump does not cavitate (Volk 2014).

Available NPSH is calculated using the following equation:

$$\text{Available NPSH} = \frac{P_a}{\gamma_m} - \frac{P_v}{\gamma_m} + \frac{d}{SG_m} - z_2 - H_L \quad (43)$$

where  $P_a$  is the local atmospheric pressure,  $\gamma_m$  is the specific weight of the mixture,  $P_v$  is the vapor pressure of water,  $d$  is the digging depth,  $z_2$  is the height from the datum to the pump (shown previously in Figure 1 as the channel bottom), and  $H_L$  are the head losses. If the available NPSH is less than the required NPSH then a ladder pump is added to the cost estimate.

### **U.S. Army Corps of Engineers Method of Production Estimate**

The U.S. Army Corps of Engineers developed a database of typical dredge production rates based on typical dredge sizes and pipeline length. The cost estimating program uses the pipeline lengths and production rates from USACE as another method to determine production. The user can choose to calculate the production from the spreadsheet's method as discussed previously or from the USACE method. If the USACE method is chosen, the spreadsheet will interpolate from the dredge size and pipeline length entered on the Data Input tab.

The method that the U.S. Army Corps of Engineers developed for estimating production started with a compilation of typical dredge production rates based on the dredge size and pipeline length. Using the pipeline length entered into the Data Input tab the production rate is interpolated from the values of typical rates. If the rate is insufficient, the program notifies the user that a booster pump needs to be added to the main Data Input page. Table 3 shows the production chart used in the cost estimating program from the U. S. Army Corps of Engineers.



**Table 3: USACE Estimate Production Chart**

| Production Charts (Used for USACE Estimate) |                  |                     |                  |                     |                  |                     |
|---|------------------|---------------------|------------------|---------------------|------------------|---------------------|
| Dredge size (in)                            | Pipe Length (ft) | Production (cy/hr.) | Pipe Length (ft) | Production (cy/hr.) | Pipe Length (ft) | Production (cy/hr.) |
| 12  | 2225             | 270                 | 4450             | 180                 | 6675             | 80                  |
| 14  | 3000             | 380                 | 6000             | 250                 | 8500             | 110                 |
| 16  | 3430             | 500                 | 6860             | 330                 | 9800             | 140                 |
| 18  | 4240             | 650                 | 8480             | 420                 | 11660            | 180                 |
| 20  | 4520             | 800                 | 9040             | 520                 | 12995            | 220                 |
| 22  | 4500             | 1000                | 9000             | 650                 | 13000            | 280                 |
| 24  | 5650             | 1200                | 11300            | 780                 | 15820            | 330                 |
| 27  | 6875             | 1500                | 13750            | 980                 | 19375            | 420                 |
| 30  | 10380            | 1800                | 20760            | 1170                | 29410            | 500                 |
| 32  | 11567.5          | 1836                | 23135            | 1193                | 32597.5          | 509                 |

## DEVELOPMENT OF THE COST ESTIMATE

The total average production rate is used in conjunction with various price assumptions to estimate the cost of a dredging project. The total cost to execute a dredging project is divided into two major components: mobilization/demobilization costs and operating cost. The mobilization and demobilization costs, which incorporates the transportation of the dredging equipment to and from a job site, can be difficult to predict. Randall (2017) identified the operating costs to include: fuel, lubricants, dredge crew, land support crew, routine maintenance and repairs, major repairs and overhauls, depreciation, overhead, and profit. Procedures set forth by Bray et al. (1997) and Randall (2004), are used to combine the cost data with the estimated project completion time in order to calculate the total cost estimation. Once the production is determined the cost estimate is calculated. The major components of the cost estimate are the project duration, mobilization, demobilization and operating costs.

To calculate the project duration, the time the dredge is operating within a month is estimated. Labor rates are added hourly along with equipment, material and overhead. The most current labor rates for the dredging crew were obtained from the U.S. Bureau of Labor Statistics (2017) and RSMeans Heavy Construction Labor Data (2018); additionally, fuel costs were obtained from the U.S. Energy Information Administration. Since wages and fuel costs are location dependent, these costs must be adjusted to reflect regional differences. Equipment capital costs are estimated using data provided by Bray et al. (1997) and RSMeans Heavy Construction Indexes (2018).

## Fuel

The cost of fuel can approach 30% of the total cost of a dredging project and is one of the most expensive parts of running a dredge. Fuel costs cover all the costs associated with the dredge engines, horsepower on the dredge, and lubricants needed for the dredge. The daily usage for fuel is entered directly in gallons and multiplied by the cost per gallon for the fuel. The formula from Bray et al. (1997) is used as follows:

$$Consumption \left( \frac{gal}{day} \right) = Installed Power (hp) \times Daily Power (hrs) \times .0481 \left( \frac{gal}{hph} \right) \quad (44)$$

where the installed power is the total installed horsepower on the dredge, the daily power is an estimate of how many hours a day the dredge is operating at 100% of its installed horsepower, and 0.0481 is the gallons of fuel consumed per horsepower-hour (hph). The cost estimating program averages the default inputs for the hours spent at 100%, 75%, and 10% power to find the 100% power per day and the user can adjust the values as needed. The fuel costs are from the U.S. Energy Information Administration (2018) and the daily lubrication costs are 10% of the daily fuel cost. The fuel costs and the Cutter Suction Dredge Cost Estimating Program assume the dredge is operating with 100% energy efficiency. Water depth, soil composition, sailing speeds, and amount of maneuvering can all affect fuel efficiency. Specific dredge companies try to maximize fuel efficiency to keep costs low.

## Capital Cost

The dredge capital cost is the initial price to build a dredge. The capital investment for a new cutter suction dredge can cost tens of millions of dollars, depending on the size of the dredge and

the amount of specialized equipment, because of the high initial costs many dredges currently in operation are many years old. The capital cost items are initially from Bray et al. (1997) with the revised costs from the RSMeans Heavy Construction (2018) annual cost indices.

### **Repairs and Maintenance**

The capital cost is used to estimate the cost of maintenance, insurance, and depreciation costs. Costs of maintenance and repairs can account for 20% of the total dredging job costs. Regular maintenance consists of minor repairs, preventative maintenance on the engines and dredge equipment, painting, cleaning and routine upkeep of the dredge. Regular maintenance can be completed while the dredge is working and has no impact on the work schedule. Maintenance helps keep the dredge and equipment running efficiently and hopefully ensures fewer unexpected repairs. Bray et al. (1997) approximates the regular maintenance and repairs costs by multiplying the capital cost of the dredge by 0.00044 for cutter suction dredges. For any major repairs that require a vital piece of machinery or equipment to be shut down Bray et al. (1997) multiplies the capital cost of the dredge by 0.0003.

### **Pipeline**

The pipeline costs are determined from Bray et al. (1997) by multiplying the total number of pipeline sections by the cost per section obtained from RSMeans Heavy Construction (2018). The average pumping distance entered on the data input page of the cost estimating program is used to determine the costs of the main pipe lengths. The total length of pipeline is divided between the percent floating, percent submerged, or the percent of pipeline on shore. Pipeline

that is submerged is most expensive, and floating pipeline is more expensive than pipeline on shore. The percentages of the pipeline help the cost estimating program obtain a more accurate cost for the pipeline. Depreciation of the pipeline is also considered. The useful life of a section of the pipeline that is in constant use is much shorter due to the constant abrasive wear of the dredged material pumped through the pipe. The default pipeline material in the Cutter Suction Dredge Cost Estimating Program is steel. As discussed previously, high-density polyethylene (HDPE) pipe can also be used. The cost for HDPE pipe might be less than calculated in the cost estimating program.

### **Depreciation**

Depreciation is the rate at which the dredge loses its value over time. Depreciation depends on the owner and their fiscal policy. A linear depreciation to zero is used with an assumed service life of thirty years. The daily depreciation used for the cost estimating program is calculated as the capital cost divided by the useful life and the number of days per year the dredge is in operation.

### **Insurance**

Insurance costs depends on the particular dredge used and its owner's risk tolerance. Bray et al. (1997) calculates an average insurance cost by multiplying the capital cost of the dredge by 0.025 and dividing it by the average number of working days per year. This comes to an annual insurance premium of 2.5 percent of the plant value.

## **Overhead**

Overhead costs also vary depending on the dredge owner. In the cost estimating program, the overhead costs are estimated to be 9 percent of the total daily costs of equipment and pipeline as recommended by Bray et al. (1997). In the cost estimating program additional space is left for the program user to add any specific costs relevant to a particular project, as a lump sum or a daily cost. The time required to complete the dredging project is calculated based on the production rate and the hours per month the dredge is in operation. This value is multiplied by the daily cost to obtain the total cost of execution.

## **Crew and Labor**

Dredges require a crew to conduct dredging operations and run the vessel for mobilization and demobilization transits. The crew keeps the maintenance on the dredge up to date and runs the day to day operations. The crew includes deck and engineering departments, as well as dredge operators. Depending on the size of the dredge, the complexity of the engines, if automation is used, and the length of the project and transit, the number of crew members can vary. The cost estimating program estimates the number of crew positions based on recommendations from Bray et al. (1997), and the crew numbers for the U. S. Army Corps of Engineers dredges. The program user can select additional crew depending on the specific job if necessary. The hourly wage rate for each of the crew members is in the program based on 2018 U.S. Bureau of Labor Statistics (2017), and RSMeans Heavy Construction Cost Data (RSMeans, 2018). The user can also enter specific hourly wages if available.

## **Mobilization and Demobilization**

Mobilization and demobilization costs are the prices associated with the transportation of dredging equipment to and from the job site. These costs are difficult to predict as they can vary based on the distance and route of travel, time of year, and type of dredge contract. No two dredges usually start or end in the same place and estimating the cost to move each dredge can vary greatly from one project to the next. Estimating the mobilization/demobilization cost is primarily based on the distance to and from the job site, the cost of transporting additional crew and equipment to the job site, and may include revenue lost due to set-up downtime. The cost estimating program allows the program user to either estimate the mobilization cost from Bray et al. (1997), from the historical trend, leave the mobilization out of the final estimated project cost, or manually enter a specific cost.

The program user can enter a self-determined mobilization/demobilization cost or use the cost estimating program to estimate the mobilization cost from two different options. The default choice is calculated from the mobilization time and cost from Bray et al. (1997), a cost inflation of 1.167 was added to the final total from Bray et al. since the costs were calculated from 1997 data. The historical trend estimate is based on the median value of the mobilization and demobilization cost estimates from the ten most recent dredging projects from the U.S. Army Corps of Engineers trends.

## **Cost Factors**

Both crew wages and fuel costs are dependent on location of the dredging project. Estimated changes in costs are accounted for in the cost estimating program. RSMeans Heavy Construction Cost Data (2018) which has a year cost index table with adjusted costs for the past ten years as well as a regional cost index table for the East Coast, West Coast, Great Lakes, Gulf Cost, Alaska, and Hawaii. The total cost estimate in the cost estimating program accounts for these differences based on the region the program user enters in the defaults tab or the year entered in the data input section.

## **Beach Nourishment**

Beach nourishment is the process by which dredged material is used to replace lost or eroded sand or build up beaches on the coast in need of rehabilitation. A beach nourishment project is a specific beneficial use project which can be accomplished using dredged material. Beach nourishment has many benefits including reducing storm damage to the coast, protecting infrastructure, and creating wider beaches for the public. While more and more dredge projects now include an aspect of beneficial use, these projects can be more costly than traditional dredging projects. The additional costs come from increased pipeline lengths, more workers on shore, and environmental surveys. Regulation is a necessary and important part of dredging, and the placement of the dredged material must follow all state and federal laws. For beach nourishment dredge projects, the Clean Water Act (CWA) section 404 needs to be followed. The Clean Water Act gives the U. S. Army Corps of Engineers the authority to authorize all discharges of dredged material following the Environmental Protection Agency (EPA)'s



guidelines. Beach nourishment projects must also get approval from the state to ensure state water quality standards are met. To meet these standards the National Environmental Policy Act (NEPA) must be followed. Included in this policy is the need to have an Environmental Assessment (EA) or an Environmental Impact Statement (EIS). The EA and the EIS must be approved and analyzed by the state and the USACE.

There are many types of beneficial use projects that can be created using dredged material. Some examples are habitat creation or restoration, agriculture reuse, bird islands or nesting areas, and beach nourishment. An example of a beach nourishment project is shown in Figure 11. The dredged material is added to the original shoreline and used to create a wider beach.

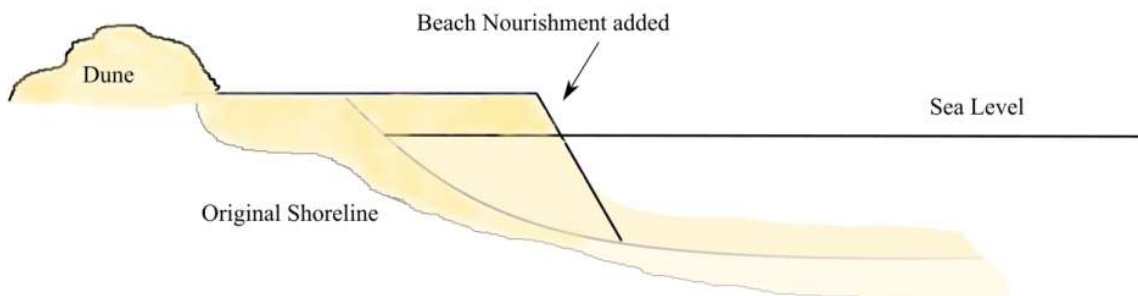

**Figure 11: Example of a Beach Nourishment Project**

If the user is estimating a dredge project that includes beach nourishment, additional information is needed to estimate the final cost, including the extra beach nourishment pipeline length, which

is added to the data input section of the cost estimating program. Once the program user changes the default section to beach nourishment the cost estimating program will include the added costs of the extra pipeline and booster pumps, extra beach crew, equipment, environmental protection and monitor surveys.

## USING THE COST ESTIMATING PROGRAM

### **Program Organization**

The Cutter Suction Dredge Cost Estimating Program consists of user input and automatic calculations. It was designed so the user can be flexible in the level of detail provided for each dredging project. There are nine tabs in the cost estimating program and it is broken up into User Input, including data input and defaults, Mobilization and Demobilization, Project Execution, and Production which includes calculations for critical velocity, head loss, net positive suction head, and the production estimation.

### **Data Input**

The main input page is labeled data input and includes all the specific information for the dredge project the user wishes to include. Table 4 shows the main data inputs from the Cutter Suction Dredge Cost Estimating Program.

Table 4: Cutter Suction Dredge Properties from Main Data Input Sheet

| Main Inputs                |         |            |         |         |
|----------------------------|---------|------------|---------|---------|
| Year                       | 2018    |            |         |         |
| Dredge size ( $D_d$ ):     | 30      | in         |         |         |
| Quantity to be dredged:    | 1000000 | cy         |         |         |
| Bank Height:               | 5       | ft         |         |         |
| Digging Depth:             | 30      | ft         |         |         |
| Fuel Cost:                 | \$2.50  | per gallon |         |         |
| Max Pumping Distance:      | 50000   | ft         |         |         |
| Avg Pumping Distance:      | 50000   | ft         | Average | Reserve |
| % Floating Pipeline:       | 10      | →          | 5000    | 0       |
| % Submerged Pipe:          | 0       | →          | 0       | 0       |
| % Shore Pipe:              | 90      | →          | 45000   | 0       |
| Beach Nourishment Pipeline | 11000   | ft         |         |         |
| Number of Boosters:        | 1       |            |         |         |
| Additional Boosters?       | No      |            |         |         |
| Ladder Pump Required?      | No      |            |         |         |
| Production Rate:           | 2355    | cy/hr.     |         |         |
| Production Override:       | 0       | cy/hr.     |         |         |
| Sediment Type              |         |            |         |         |
| Material                   | Percent | SG         | Factor  |         |
| Mud and Silt               | 0.00%   | 1.2        | 3       |         |
| Mud and Silt               | 90.00%  | 1.3        | 2.5     |         |
| Mud and Silt               | 0.00%   | 1.4        | 2       |         |
| Loose Sand                 | 0.00%   | 1.7        | 1.1     |         |
| Loose Sand                 | 10.00%  | 1.9        | 1       |         |
| Comp. Sand                 | 0.00%   | 2          | 0.9     |         |
| Stiff Clay                 | 0.00%   | 2          | 0.6     |         |
| Comp. Shell                | 0.00%   | 2.3        | 0.5     |         |
| Soft Rock                  | 0.00%   | 2.4        | 0.4     |         |
| Blasted Rock               | 0.00%   | 2          | 0.25    |         |

### ***Dredge size***

The size of a dredge is measured by the inside diameter of the discharge pipeline in inches. This number is used in many aspects of the cost estimating program and is the basis for determining the dredge production rates, equipment costs, crew sizes and production. The program user can choose between a dredge size of 8 to 32 inches.

### ***Quantity to be dredged***

This is the volume in cubic yards of the material to be dredged.

### ***Bank Height***

The bank height is the face of the material to be dredged, or the average depth of the cut to be made in the dredging channel. The Cutter Suction Dredge Cost Estimating Program calculates the bank height efficiency, or the bank factor to apply to the production rate. Turner (1996) developed a graph to calculate the bank factor using the ratio of cutter diameter to the bank height. Figure 12 shows the bank height and cutter diameter ratio which is used to find the bank height efficiency.

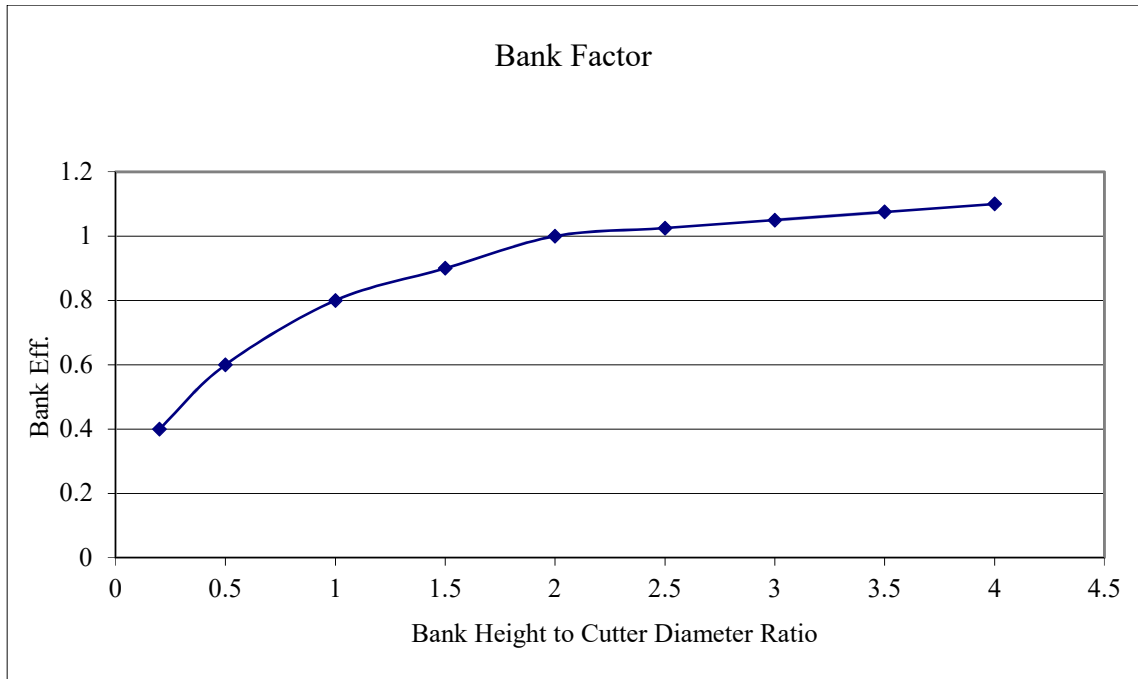

**Figure 12: Bank Factor Determination (Turner, 1996)**

***Fuel Cost***

The fuel cost is the current price of fuel per gallon. The user can input a fuel cost or use the default fuel costs. Fuel costs by region are listed in the database tab of the Cutter Suction Dredge Cost Estimating Program.

***Average Pumping Distance***

The average pumping distance is the average length of pipeline from which the dredged material is pumped from the dredging site to the placement site.

***Number of Boosters***

Booster pumps are needed if the main pump head is less than five percent greater than the head losses, if the pipeline is too long for the main dredge pump to maintain velocity (Randall and Yeh, 2013). If so, the spreadsheet prompts the user to add a booster pump to the input page, and

the booster pump's head is added to the main pump's head. Additional booster pumps can be added until the total system head is greater than the head losses, and the slurry can be transported down the pipeline. The user can also add booster pumps if desired, more booster pumps might lower the dredging costs by increasing dredge production.

### ***Sediment Type***

There are many areas of the country that cutter suction dredges operate. Each area has different site characteristics, including unique sediment types. A fine-grained silt is much easier to pump than larger grained clay. The Cutter Suction Dredge Cost Estimating Program has different sediment types listed that the user can leave as default or update with the specific dredge site sediment characteristics. The Cutter Suction Dredge Cost Estimating Program uses a factor in the program to account for the percentages of sediment type. Loose sand with a specific gravity of 1.9 is the base with a factor of 1. Any sediments with a specific gravity less than 1.9 are easier to transport through the pipeline and therefore have a higher factor which is multiplied to the production rate, increasing the final production rate. The sediments with a specific gravity of greater than 1.9 are harder to transport and have a smaller factor multiplied to the production rate, lowering the final production.

### ***Cost estimate***

On the right side of the main input page is the program output. Here the total cost of the project, cost per hour, cost per cubic yard and time required are shown. The costs are also broken down further with crew costs, equipment costs, pipeline costs, overhead costs and any additional profit or costs the user added. The user has the option to include the mobilization and demobilization

costs in the final cost or leave it separate. Table 5 shows an example of the final cost estimate from the cutter suction dredge spreadsheet.

**Table 5: Final Cost Estimate Example from Main Data Sheet Input**

| <b>Final Cost Estimate - Year 2018</b> |                            |
|--|----------------------------|
| Total Cost of Project:                 | \$3,802,561.19             |
| Cost per Hour                          | \$5,969.44 per hour        |
| Cost per Yard <sup>3</sup>             | \$3.80 per yd <sup>3</sup> |
| Time Required:                         | 0.9 Months                 |
|  |                            |
|  |                            |
| Crew Cost:                             | \$23,955.60 per day        |
| Equipment Costs:                       | \$46,679.93 per day        |
| Pipeline Costs:                        | \$403.19 per day           |
| Overhead Costs:                        | \$6,393.48 per day         |
| Additional Costs:                      | \$55,000.00 per day        |
| Total Cost of Execution:               | \$132,432.21 per day       |
|  |                            |
| Contractor's Profit                    | 9.00%                      |
| Contractor's Bond                      | 1.00%                      |
|  |                            |
| Total Mob/Demob Cost:                  | \$224,088.23               |
| Include in Total Cost?                 | Yes                        |

### Defaults

The next tab in the Cutter Suction Dredge Cost Estimating Program is for the default calculations the program needs to make a cost estimate. The left column consists of suggestions for default values, and the user can leave it or change the option depending on the project. These values do not need to be changed and are based on the current equipment and economy. There are five subgroups of the default values, general, mobilization and demobilization, crew rates, execution, and production. Table 6 shows the defaults page from the Cutter Suction Dredge Cost Estimating Program.



**Table 6: Defaults Page in Cutter Suction Dredge Cost Estimating Program**

|            | Default Value        | Chosen Value         | Units                                 | Description   |
|------------|----------------------|----------------------|---------------------------------------|---|
| General    | 8                    | 8                    | hrs./day                              | Crew shift duration   |
|            | 3                    | 3                    | /day                                  | Number of shifts per day                                      |
|            | Gulf Coast           | Gulf Coast           |                                       | Region  |
| Mob/Demob  | Bray, Bates and Land | Bray, Bates and Land |                                       | Method for estimating mobilization and demobilization costs   |
|            | 200                  | 200                  | /day                                  | Supplies and small tools                                      |
|            | 600                  | 600                  | /day                                  | Support equipment with operators                              |
|            | 200                  | 200                  | /day                                  | Fuel (plant idle)   |
|            | 25                   | 25                   | /man /day                             | Subsistence   |
|            | 100                  | 100                  | miles/day                             | Towing speed  |
|            | 4000                 | 4000                 | /day                                  | Towing vessel cost  |
|            | 1                    | 1                    |                                       | Number of vessels   |
|            | 150                  | 150                  | /man                                  | Travel expenses   |
|            | 200                  | 200                  | /day                                  | Local hire  |
|            | 1                    | 1                    | Days                                  | Demob time required to prepare dredge for transfer from site  |
|            | 20                   | 20                   | Miles                                 | Demobilization transfer all from site Distance                |
|            | 1                    | 1                    | Days                                  | Demobilization time to Prepare Dredge for Storage             |
|            | 1                    | 1                    | Days                                  | Demobilization time to Prepare Pipeline for Storage           |
|            | \$0.00               | \$0.00               | dollars                               | Demobilization other lump sum cost                            |
|            | 20                   | 20                   | Miles                                 | Mobilization transfer to site distance                        |
|            | 3                    | 3                    | men/shift                             | Mobilization transfer to site crew size                       |
|            | 1                    | 1                    | Days                                  | Mobilization Time Required to Prepare Dredge for work at site |
| \$0.00     | \$0.00               | dollars              | Mobilization other lump sum cost      |   |
| Crew Rates | \$ 62.00             | \$ 62.00             | /hour                                 | Master  |
|            | \$ 51.00             | \$ 51.00             | /hour                                 | Assistant Master  |
|            | \$ 35.00             | \$ 35.00             | /hour                                 | Mates (2 <sup>nd</sup> or 3 <sup>rd</sup> )                   |
|            | \$ 61.00             | \$ 61.00             | /hour                                 | Chief Engineer  |
|            | \$ 37.00             | \$ 37.00             | /hour                                 | Assistant Chief Engineer                                      |
|            | \$ 35.00             | \$ 35.00             | /hour                                 | Assistant Engineer (2 <sup>nd</sup> or 3 <sup>rd</sup> )      |
|            | \$ 31.00             | \$ 31.00             | /hour                                 | Marine Electrician  |
|            | \$ 26.00             | \$ 26.00             | /hour                                 | Marine Oiler  |
|            | \$ 30.00             | \$ 30.00             | /hour                                 | Electronics Mechanic  |
|            | \$ 39.60             | \$ 39.60             | /hour                                 | Foreman   |
|            | \$ 43.60             | \$ 43.60             | /hour                                 | Leverman  |
|            | \$ 34.35             | \$ 34.35             | /hour                                 | Laborer   |
|            | \$ 48.60             | \$ 48.60             | /hour                                 | Equipment Operator  |
| \$ 40.30   | \$ 40.30             | /hour                | Cook                                  |   |
| 9%         | 9%                   |                      | Overhead                              |   |
| Execution  | Upland               | Upland               |                                       | Disposal Method   |
|            | 300                  | 300                  | days/year                             | Days per year dredge is in use                                |
|            | 15.6                 | 15.6                 | hrs./day                              | Dredge operating at 100%                                      |
| Production | CSDCEP               | CSDCEP               |                                       | Method for production estimate                                |
|            | 10                   | 10                   |                                       | Discharge lift (ft)   |
|            | 44                   | 44                   |                                       | Ladder length (ft)  |
|            | 1.025                | 1.025                |                                       | Specific gravity of surrounding water                         |
|            | 0.1                  | 0.1                  |                                       | K for ball joints   |
|            | 1.9                  | 1.9                  |                                       | K for swivel joints   |
|            | 1.6                  | 1.6                  |                                       | K for head losses at suction                                  |
|            | 0.5                  | 0.5                  |                                       | K for head losses at discharge                                |
|            | 0.3                  | 0.3                  |                                       | K for elbows  |
|            | 1.35                 | 1.35                 |                                       | Maximum possible SG of slurry                                 |
|            | 1.2                  | 1.2                  |                                       | Minimum allowable SG of slurry                                |
|            | 5                    | 5                    |                                       | Percent of total system head that must be greater than Hp-HL  |
|            | Spud Carriage        | Spud Carriage        |                                       | Type of Dredge  |
|            | No                   | No                   |                                       | Enter pump characteristics curves manually?                   |
|            | 0.4                  | 0.4                  | mm                                    | d <sub>50</sub>   |
|            | 2.1                  | 2.1                  |                                       | SG Solids   |
|            | 0.00015              | 0.00015              | feet                                  | Pipe Roughness  |
|            | 0.00000117           | 0.00000117           |                                       | Kinematic Viscosity   |
| 0.0012     | 0.0012               |                      | Dynamic Viscosity                     |   |
| 0          | 0                    |                      | Pipe Inclination                      |   |
| Matousek   | Matousek             |                      | Method for calculating V <sub>c</sub> |   |

### ***General***

The general section consists of the crew shift duration; the number of crew shifts per day and the region of the country the project is located.

### ***Mobilization/Demobilization***

The next section consists of the default parameters for calculating the mobilization and demobilization costs. The user has a choice for which method of calculation to use as discussed in the cost estimating section, either the method from Bray et al. (1997), the historical trend calculation, or a manual entry. There are also typical daily costs, times, and distances of mobilization and demobilization listed.

### ***Crew Rates***

The crew rates are given from the U.S. Bureau of Labor Statistics (2017) and RSMeans Heavy Construction Cost Data (RSMeans, 2018). A typical dredge crew and sailing crew is assumed by the program.

### ***Execution***

There are three choices the program user has for the dredged material disposal method, upland, open water, or beach nourishment.

### ***Production***

The final section in defaults is for the production calculation. The user has the option to calculate the production from the U. S. Army Corps of Engineering method of production estimation or from the program's equations. The minor loss coefficient,  $K$  is listed for different parts of the dredge and pipeline. There is also a choice for the type of dredge either a spud carriage, or a fixed spud. If the pipeline has any inclination there is a section to add the degree of pipe

inclination for the program to calculate using Equation (24). The dredging efficiency value in Equation (41) uses 0.5 for a fixed spud and 0.75 for a spud carriage.

### **Mobilization and Demobilization**

The Mobilization tab is where the mobilization and demobilization information are calculated. The user can manually input this information if it is provided. This section includes the typical values for equipment, supplies, crew, fuel, and other mobilization/demobilization values. There are three ways the user can choose to calculate the mobilization and demobilization costs. Bray et al. (1997) developed a method for mobilization and demobilization including prices in 1997. This method was used in the Cutter Suction Dredge Cost Estimating Program and a cost inflation was added to account for the twenty years since Bray et al. (1997) developed their method. The user has the option of adding the mobilization and demobilization cost using the manual entry block if the number is known or estimated. The final method is the historical trend. The historical trend estimate is based on the average of the ten most recent cutter suction dredging projects mobilization and demobilization cost estimates from the U.S. Army Corps of Engineers (USACE 2018).

### **Execution**

The Execution tab contains the production calculations. The user can add additional daily costs here if needed. The crew rates, equipment values, and pipeline costs are shown in the project execution tab. As previously discussed, the user can use the spreadsheet calculations for total

production or use the USACE method.

### **Data Base**

The Data Base tab is for references and acts as the collection sheet for all valves, assumptions, and data used throughout the cost estimating program. The user does not need to reference or change any values on this tab.

### **Production**

The Production tab is useful for adding specific pump characteristics. If the user lacks specific pump information, the nondimensionalized pumps equations will be used for estimating. Table 7 and Figure 13 show the relationship between the 24-inch x 24-inch GIW dredge pump dimensional curves to dimensionless pump characteristics. There are two conversions for smaller and larger pumps.

**Table 7: Relationship from Dimensional to Nondimensional Pump Characteristics**

| Georgia Iron Works dredge pump<br>24"X 24" dredge, 62" impeller, 450rpm |      |        |              | Pump Characteristics                    |           |          |             |             |            |
|---|------|--------|--------------|---|-----------|----------|-------------|-------------|------------|
|   |      |        |              | Nondimensionalized pump characteristics |           |          |             |             |            |
|   |      |        |              | D:                                      | 62 in     |          | 5.17 ft     |             |            |
|   |      |        |              | Speed:                                  | 450 rpm   |          | 47.12 rad/s |             |            |
| Q (gpm)   | BHP  | H (ft) | Efficiency % | Q (dim)                                 | BHP (dim) | BHP (hp) | ca H (dim)  | H (ft) calc | Efficiency |
| 4000  | 750  | 318    | 50           | 1.37                                    | 0.54      | 212.80   | 17.27       | 318.00      | 50         |
| 8000  | 900  | 312    | 60           | 2.74                                    | 0.64      | 255.36   | 16.94       | 312.00      | 60         |
| 12000   | 1300 | 305    | 70           | 4.11                                    | 0.93      | 368.86   | 16.56       | 305.00      | 70         |
| 16000   | 1500 | 298    | 75           | 5.49                                    | 1.07      | 425.61   | 16.18       | 298.00      | 75         |
| 20000   | 1720 | 288    | 80           | 6.86                                    | 1.23      | 488.03   | 15.64       | 288.00      | 80         |
| 24000   | 1860 | 279    | 81.5         | 8.23                                    | 1.33      | 527.75   | 15.15       | 279.00      | 81.5       |
| 28000   | 2000 | 270    | 83           | 9.60                                    | 1.43      | 567.48   | 14.66       | 270.00      | 83         |
| 32000   | 2400 | 260    | 84           | 10.97                                   | 1.71      | 680.97   | 14.12       | 260.00      | 84         |
| 36000   | 2600 | 250    | 84           | 12.34                                   | 1.86      | 737.72   | 13.57       | 250.00      | 84         |
| 40000   | 3000 | 242    | 84           | 13.71                                   | 2.14      | 851.22   | 13.14       | 242.00      | 84         |
| 44000   | 3100 | 235    | 84           | 15.08                                   | 2.22      | 879.59   | 12.76       | 235.00      | 84         |
| 48000   | 3300 | 228    | 83           | 16.46                                   | 2.36      | 936.34   | 12.38       | 228.00      | 83         |
| 52000   | 3600 | 218    | 81           | 17.83                                   | 2.57      | 1021.46  | 11.84       | 218.00      | 81         |
| 56000   | 4000 | 210    | 80           | 19.20                                   | 2.86      | 1134.95  | 11.40       | 210.00      | 80         |
| 60000   | 4200 | 200    | 75           | 20.57                                   | 3.00      | 1191.70  | 10.86       | 200.00      | 75         |

The user can also input a specific dredge or booster pump manually in this section of the program. Figure 13 shows the dimensionless curve for this same GIW dredge pump.

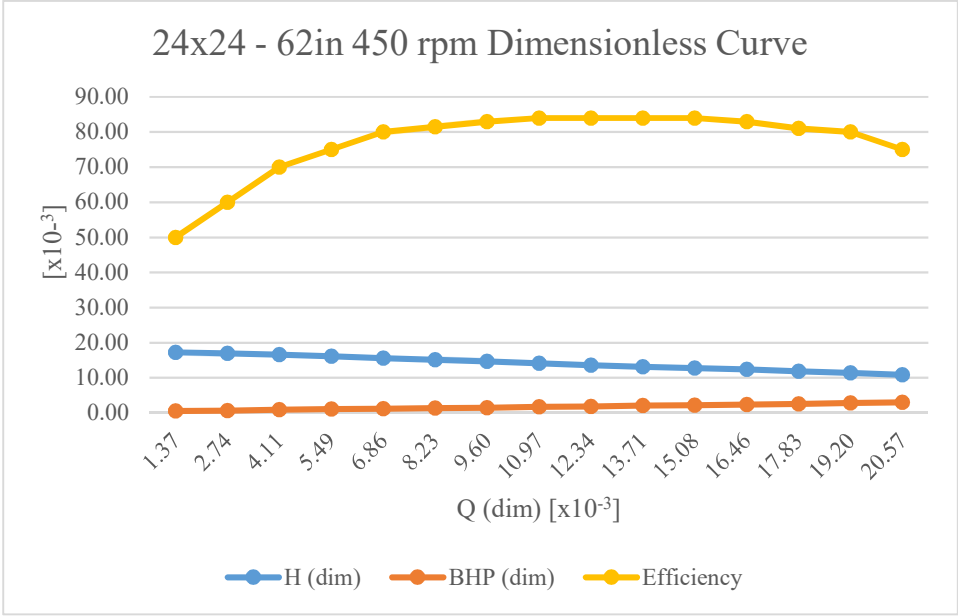

**Figure 13: Dimensionless Characteristics Curve**

**Head Loss**

In the Head Loss tab, the head losses in the pipeline are calculated due to friction. Minor losses due to pipe joints and bends are also calculated here. This section shows the total system curve that includes the system head curve, pump head curve, optimal flow rate, and critical flow rate.

### **Critical Velocity**

The  $V_c$  tab calculates the critical velocity using either the Wilson method or the Matousek equation. The user can choose to use the Wilson method (2006) or the Matousek equation to calculate the critical velocity.

### **Net Positive Suction Head**

The Net Positive Suction Head or NPSH tab is the last step of the program. This page shows the available and required net positive suction head. If the available NPSH is less than the required NPSH then cavitation will occur, and the program will add a ladder pump to the estimate. The required NPSH is determined from the pump curve and interpolation. Required NPSH is a function of flowrate and impeller speed. When flowrate and impeller speed increases, the required NPSH will increase. Available NPSH is determined as shown in Equation (43).

## **RESULTS**

In order to test the cutter suction dredge program for accuracy sixteen actual dredge projects were selected from different regions in the United States from 2016 to 2018. Of those sixteen projects, four were specifically beach nourishment dredging projects. The final cost estimate from the Cutter Suction Dredge Cost Estimating Program was compared to the winning bid, and the government estimate for each project. The project cost data was obtained from the U.S. Army Corps of Engineering Navigation Data Center (NDC 2018) and usually only includes the name of the project, date, location, volume of material to be dredged, type of dredge, government cost estimate, and contractors winning bid. The USACE collects the data from dredging projects across the country and provides the winning bid and government estimate to the public. The U.S. Army Corps of Engineers also combine the data yearly to show the annual dredging cost information. In order to accurately estimate the costs for dredging projects it is important to know as much information as possible. This cost comparison was used with minimal information, such as the user might have. Even with minimal information, the costs were comparable with the government estimates and the winning bids.

### **Cost Comparison**

To determine the government estimate, the USACE evaluates the project in their own cost estimating software. The government estimate is used to determine the feasibility of the proposed dredging project, and to evaluate the reasonability of the contractors bid. Usually, the winning bid is the contractor's lowest price that meets the project requirements. The contractor is



sometimes provided with more detailed information for the proposed project. The more information given, the better the cost estimate. The contractor also knows the accurate status of their equipment, and personnel. The government lacks the detailed knowledge of equipment and personnel, as this is dependent on the contractor. Table 8 and Table 9 show the sixteen projects used to compare the government estimates, winning bids, and cost estimating program estimate. Included in the table are five different regions of the country including, Alaska, Great Lakes, Gulf Coast, West Coast, and East Coast. Four beach nourishment projects are included two from the Gulf Coast and two from the East Coast. The dredge size was estimated based on the total volume to be dredged and the region. The dates range from June 2016 to June 2018. The total volume is included in cubic yards, and the three cost estimates include the government estimate, the winning bid, and the Cutter Suction Dredge Cost Estimating Program estimate. The Cutter Suction Dredge Cost Estimating Program percent differences between the government estimates and the winning bids can be seen in Table 9.

**Table 8: Projects used to Compare Cost Estimates**

| Region       | Name                           | Beach Nourishment | Dredge Size | Date       | Total volume (yd <sup>3</sup> ) | Government Est | Winning Bid  | Program estimate |
|--------------|--------------------------------|-------------------|-------------|------------|---------------------------------|----------------|--------------|------------------|
| Alaska       | Dillingham Harbor              |                   | 20          | 12/6/2016  | 110,000                         | \$895,400      | \$690,100    | \$611,509.63     |
| Detroit      | Grand Haven, MI                |                   | 20          | 12/15/2017 | 27,400                          | \$242,520      | \$242,520    | \$295,344.98     |
| Galveston    | PT Comfort                     |                   | 30          | 9/13/2017  | 2,478,518                       | \$5,517,754    | \$4,727,518  | \$5,291,164.74   |
| Galveston    | HSC Redfish June               | Beach Nourishment | 30          | 6/23/2016  | 1,500,000                       | \$15,836,150   | \$21,442,500 | \$18,661,741.60  |
| Galveston    | HSC Redfish August             | Beach Nourishment | 30          | 8/24/2016  | 4,000,000                       | \$31,692,945   | \$32,172,330 | \$29,957,066.21  |
| Galveston    | Turning Basin                  |                   | 30          | 6/2/2017   | 1,393,000                       | \$8,843,883    | \$4,669,073  | \$4,515,052.16   |
| New Orleans  | Mississippi River              |                   | 30          | 11/16/2016 | 10,314,453                      | \$16,970,285   | \$21,146,250 | \$22,805,415.00  |
| Vicksburg    | Black Maintenance              |                   | 30          | 12/15/2017 | 1,990,000                       | \$7,016,740    | \$7,993,809  | \$7,048,083.22   |
| Seattle      | Everett                        |                   | 20          | 8/17/2017  | 140,000                         | \$1,587,100    | \$1,534,999  | \$1,352,666.37   |
| Philadelphia | Wilmington Harbor              |                   | 20          | 7/26/2017  | 501,402                         | \$2,820,204    | \$2,197,752  | \$2,015,819.19   |
| Philadelphia | Brigantine Harbor, NJ          | Beach Nourishment | 30          | 5/31/2017  | 915,000                         | \$13,673,725   | \$11,168,700 | \$9,984,271.62   |
| New York     | Long Beach, NY                 | Beach Nourishment | 30          | 1/12/2018  | 4,800,000                       | \$66,083,970   | \$54,384,243 | \$52,884,843.73  |
| Savannah     | Savannah Inner Harbor          |                   | 30          | 6/21/2018  | 4,500,000                       | \$24,033,100   | \$28,988,500 | \$25,472,113.68  |
| Norfolk      | Craney Island                  |                   | 30          | 1/17/2017  | 1,400,000                       | \$5,142,730    | \$4,414,645  | \$4,953,621.66   |
| Charleston   | Joint Base Charleston          |                   | 30          | 3/6/2017   | 1,800,000                       | \$6,425,370    | \$5,861,810  | \$5,973,089.39   |
| Wilmington   | Wilmington Harbor Anchor Basin |                   | 30          | 8/2/2017   | 1,225,000                       | \$5,003,935    | \$5,896,500  | \$4,924,947.46   |

**Table 9: Percent Difference Between Estimated and Actual Costs**

| <u>Region</u> | <u>Name</u>                    |                            | <u>Percent Difference Government bid to winning bid</u> | <u>Percent Difference Winning bid to program</u> | <u>Percent Difference Government bid to program</u> |
|---------------|--------------------------------|----------------------------|---|--|---|
| Alaska        |                                |                            |   |  |   |
| Alaska        | Dillingham Harbor              |                            | 22.93%  | 11.39%   | 31.71%  |
|               |                                |                            |   |  |   |
| Great Lakes   |                                |                            |   |  |   |
| Detroit       | Grand Haven, MI                |                            | 0.00%   | 21.78%   | 21.78%  |
|               |                                |                            |   |  |   |
| Gulf Coast    |                                |                            |   |  |   |
| Galveston     | PT Comfort                     |                            | 14.32%  | 11.92%   | 4.11%   |
| Galveston     | HSC Redfish June               | Beach Nourishment          | 35.40%  | 12.97%   | 17.84%  |
| Galveston     | HSC Redfish August             | Beach Nourishment          | 1.51%   | 6.89%  | 5.48%   |
| Galveston     | Turning Basin                  |                            | 47.21%  | 3.30%  | 48.95%  |
| New Orleans   | Mississippi River              |                            | 24.61%  | 7.85%  | 34.38%  |
| Vicksburg     | Black Maintenance              |                            | 13.92%  | 11.83%   | 0.45%   |
|               |                                |                            |   |  |   |
| West Coast    |                                |                            |   |  |   |
| Seattle       | Everett                        |                            | 3.28%   | 11.88%   | 14.77%  |
|               |                                |                            |   |  |   |
| East Coast    |                                |                            |   |  |   |
| Philadelphia  | Wilmington Harbor              |                            | 22.07%  | 8.28%  | 28.52%  |
| Philadelphia  | Brigantine Harbor, NJ          | Beach Nourishment          | 18.32%  | 10.60%   | 26.98%  |
| New York      | Long Beach, NY                 | Beach Nourishment          | 17.70%  | 2.76%  | 19.97%  |
| Savannah      | Savannah Inner Harbor          |                            | 20.62%  | 12.13%   | 5.99%   |
| Norfolk       | Craney Island                  |                            | 14.16%  | 12.21%   | 3.68%   |
| Charleston    | Joint Base Charleston          |                            | 8.77%   | 1.90%  | 7.04%   |
| Wilmington    | Wilmington Harbor Anchor Basin |                            | 17.84%  | 16.48%   | 1.58%   |
|               |                                | Averages                   | 17.66%  | 9.85%  | 18.11%  |
|               |                                |                            |   |  |   |
|               |                                | Beach Nourishment Averages | 25.41%  | 8.32%  | 26.73%  |

The average percent difference between the winning bid and the program estimate is 9.85% while the average percent difference between the government estimate and the winning bid is 17.66%. The average percent difference between the winning bid and the program estimate for beach nourishment projects is 9%, while the average percent difference between the government estimate and the winning bid is 25.41%. Figures 14 and 15 show the program estimate cost, government estimate, and the cost of the winning bids for each project. Figure 16 shows the same cost estimate for the beach nourishment dredging projects.

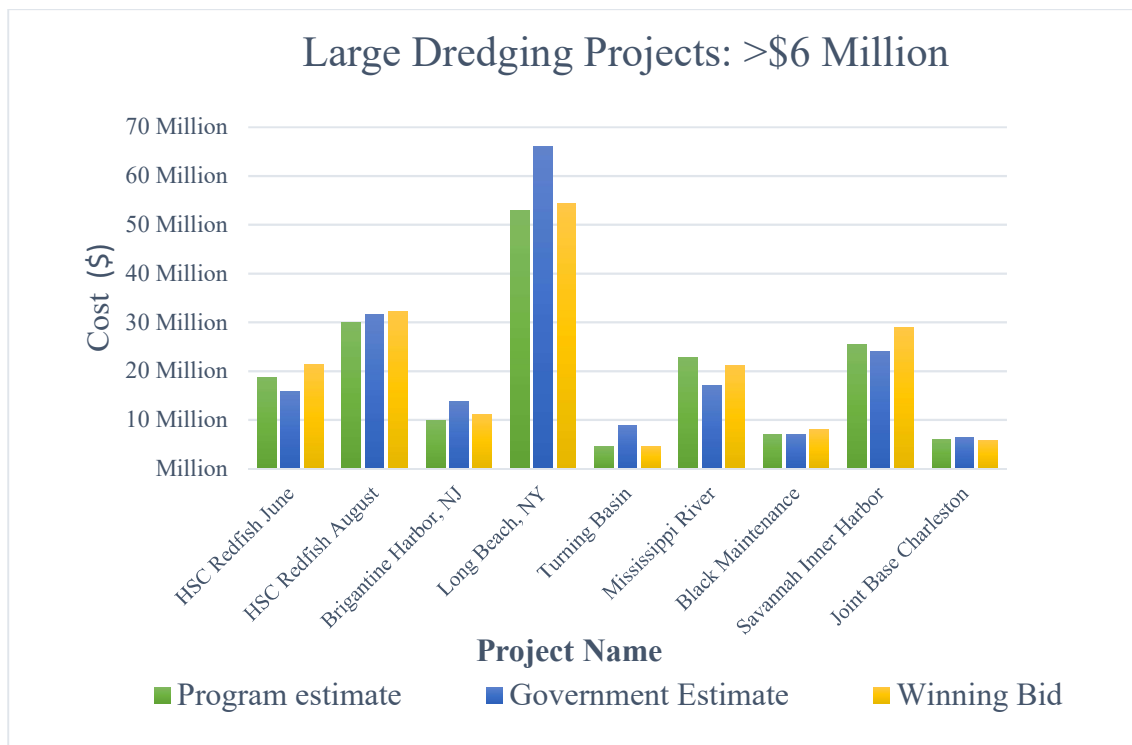

**Figure 14: Comparison of Program Estimate, Government Estimate, and Winning Bids for Large Projects**

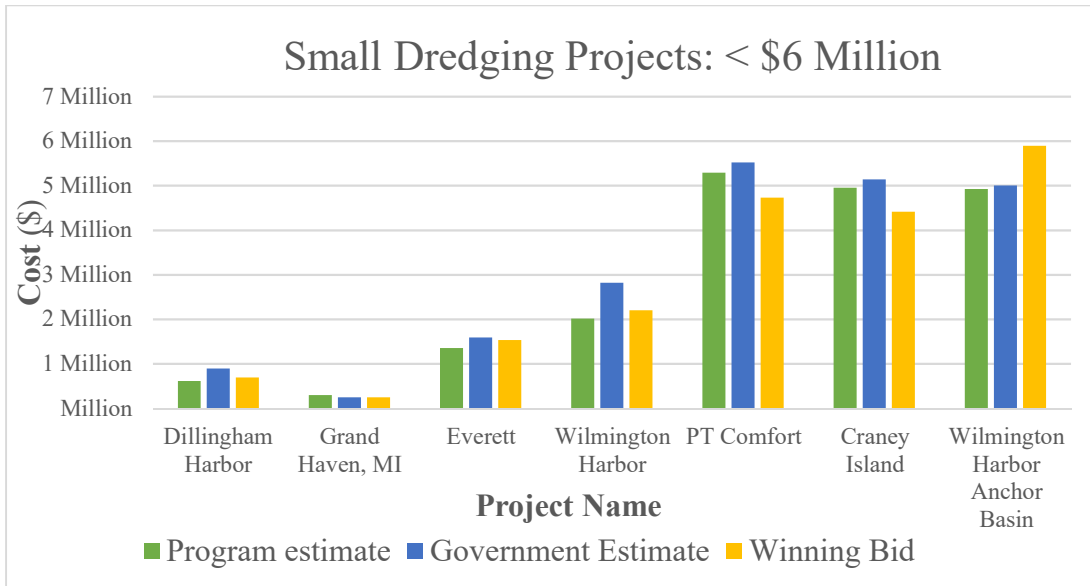

**Figure 15: Comparison of Program Estimate, Government Estimate, and Winning Bid for Small Projects**

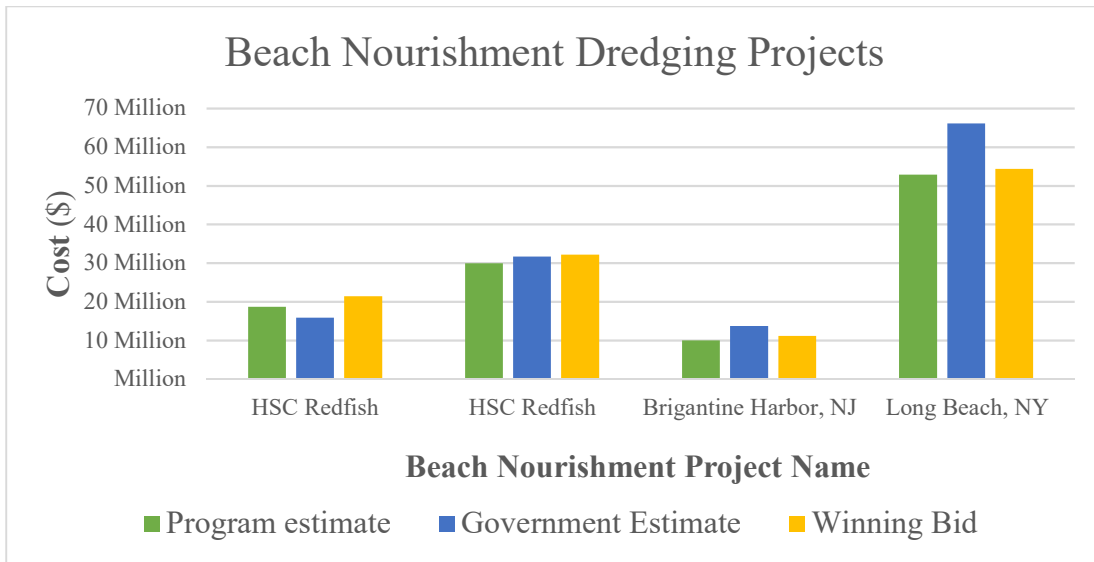

**Figure 16: Comparison of Beach Nourishment Project Costs**

Some differences in the cost estimate can be attributed to the mobilization and demobilization costs. Also, with more information known of the soil composition, pipeline length, and specific

dredge specifications, including pump curves, the estimate can be more accurate for both the government estimate and the Cutter Suction Dredge Cost Estimating Program.

### **Sensitivity Analysis**

To estimate the final cost of the dredging projects, the most general information was input into the Cutter Suction Dredge Cost Estimating Program. Depending on the specific information given, the final cost of the same dredging project can significantly vary. A sensitivity analysis was conducted to determine how different inputs affect the final cost and production estimates. By changing each variable separately and holding all other parameters constant, the knowledge of how critical each input is, was found. The base values that remained constant for the dredge characteristics and defaults are shown in Table 10 and include the assumed base dredging project to be in 2018, located in the Gulf Coast, with the dredged material going to an upland confined disposal area. The variables selected for the sensitivity analysis were the bank height, length of discharge pipeline, volume of dredged material, sediment type, and dredge size, the defaults of which are also located in Table 10.

**Table 10: Cutter Suction Dredge Cost Estimating Program Estimate Values**

| <b>Dredge Information</b>                                   | <b>Cutter Suction Dredge Cost Estimating Program</b> |
|---|--|
| Year  | 2018   |
| Dredge Size   | 30 in  |
| Digging Depth   | 12 ft  |
| Fuel Cost   | \$3.50   |
| Region  | Gulf Coast   |
| Method for Estimating Mobilization and Demobilization Costs | Bray, Bates, and Land (1997)                         |
| Disposal Method   | Upland   |
| Type of Cutter Suction Dredge                               | Spud Carriage  |
| Bank Height   | 5 ft   |
| Length of Discharge Pipeline                                | 5,000 ft   |
| Volume of Dredged Material                                  | 1,000,000 cubic yards                                |
| Sediment Type   | 100% Loose Sand (SG 1.9)                             |

The first variable that was adjusted was bank height. Figure 17 shows the results from varying the bank height while the other factors remained constant as shown in Table 10. As bank height increases the cost per cubic yard decreases. Since bank height efficiency is an important part of calculating dredge production, it is also an important factor in the final dredge cost estimate.

Using a volume of material to be dredged of 1 million cubic yards, the larger dredges of 30 inches or more are more economical. If a smaller volume of dredged material, a smaller dredge would be used to maintain the bank height efficiency as the bank height decreases.

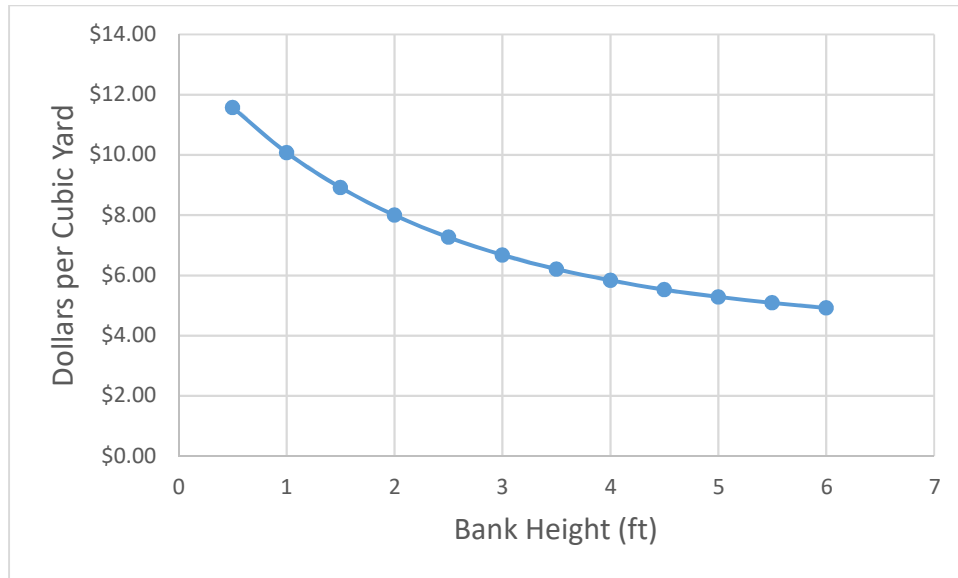

**Figure 17: Variation of Cost with Bank Height: 30-inch Dredge**

The next variable tested was discharge pipe length. Figure 18 shows the variation of cost per cubic yard with the length of discharge pipeline. The longer the pipeline the more expensive the project is. During the sensitivity analysis of discharge pipeline length, the cutter suction dredge cost estimation program prompted the user to add additional booster pumps as the length increased. The booster pumps were added as needed at 3, 4.5 and 4.5 miles, but if the user decided not to add the needed booster pumps the cost would be much higher per cubic yard.



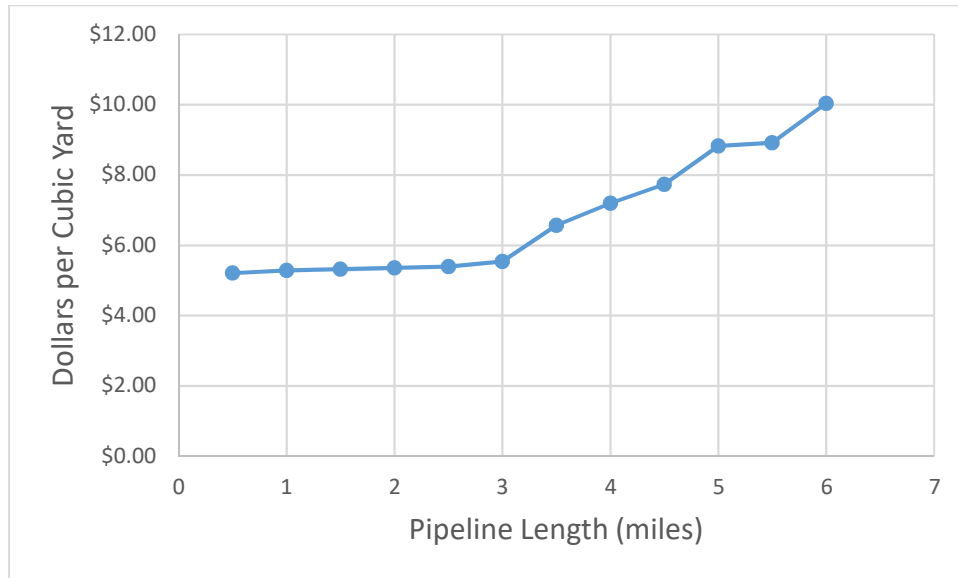

**Figure 18: Variation of Cost with Discharge Pipeline Length: 30-inch Dredge**

Figure 19 shows the variation of cost with the volume of material to be dredged. As seen the cost decreases as the volume increases. The default dredge size used for the sensitivity analysis is 30 inches. If the dredge was a smaller size it would cost more to dredge a greater volume of material, while being more economical for the smaller amounts of dredged material.

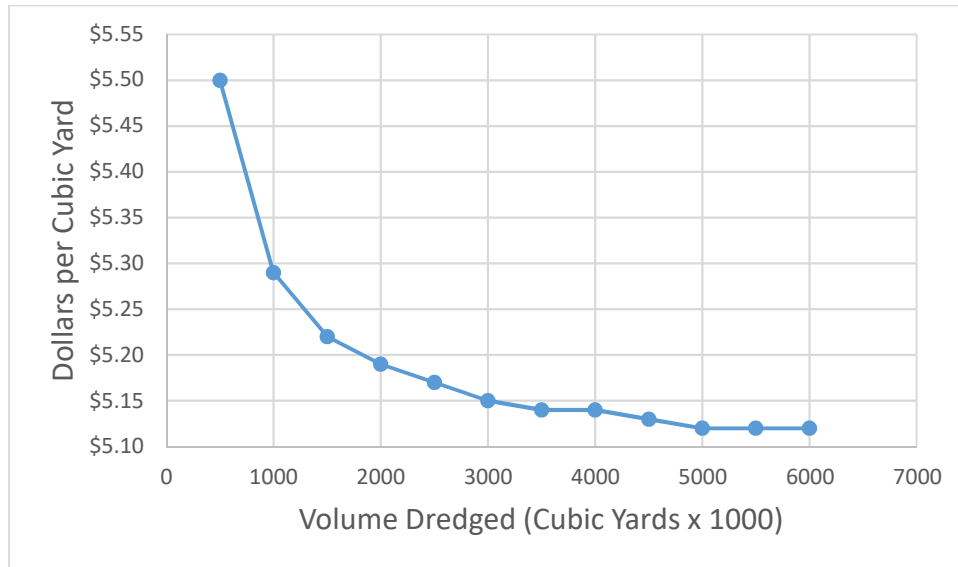

**Figure 19: Variation of Cost with Volume Dredged: 30-inch Dredge**

The variation of cost per cubic yard with sediment type is shown in Figure 20. The default used for sediment type was 100% sand with a Specific Gravity (SG) of 1.9. As the percentage of sand decreased, the remaining percentage was added as Mud and Silt with a SG of 1.3. As expected, the cost increases as the percentage of sand increases and the higher the mud and silt the lower the cost. The grain size of silt and mud is relatively small. This allows the silt and mud to be suspended in the water and much easier to transport, which reduces the final costs.

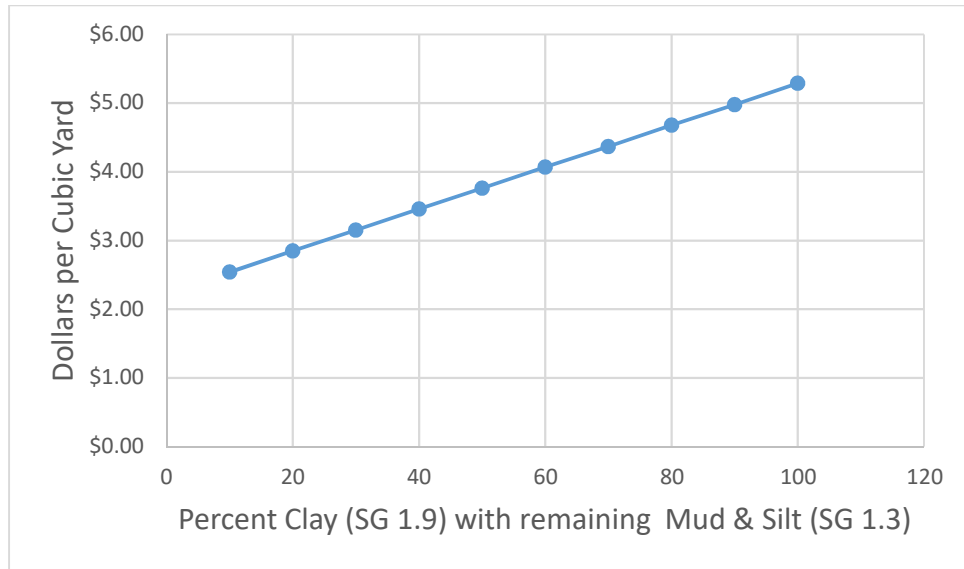

**Figure 20: Variation of Cost with Sediment Type: 30-inch Dredge**

The final sensitivity analysis shows the variation of cost with dredge size, as seen in Figure 21.

Using the default volume dredged of 1 million cubic yards, it is expected that the larger the dredge the more economical the cost, which can be verified in Figure 21.

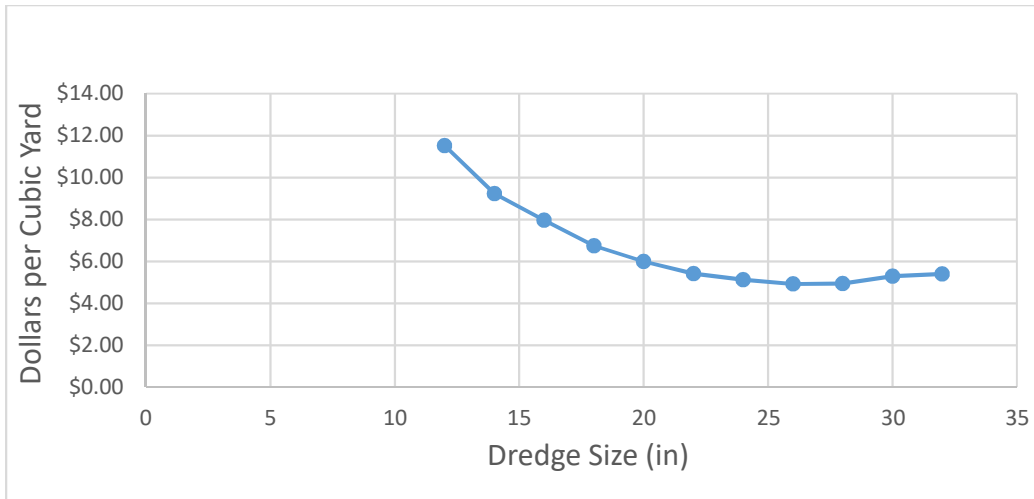

**Figure 21: Variation of Cost with Dredge Size: 30-inch Dredge**

## CONCLUSION AND RECOMMENDATIONS

To determine the level of accuracy of the Cutter Suction Dredge Cost Estimating Program, comparisons were made between the CSDCEP program and the U. S. Army Corps of Engineers (USACE) actual dredging costs. To ensure the program is effective, sixteen projects were selected and compared with the winning bids and the spreadsheet's estimate. The Navigation Data Center's website, <http://www.navigationdatacenter.us/dredge/dredge.htm>, contains the information for awarded contracts: government cost estimates, and the winning bid estimate.

Sixteen projects were selected from the USACE government estimates and winning bids from across the country from 2016-2018. The projects included the type of dredge used for the project, the location, the opening bid date, the quantity to be dredged (cubic yards), the government estimate, and the winning bid. The winning bid was submitted by the contractor that was chosen for the particular project. The final cost of the project is not provided so any additional changes are unknown. Contractors usually use historical knowledge and proprietary estimating software to provide an accurate estimate. Sometimes, the contractors have more information than is provided on the final USACE project costs that is publicly available. The average difference between the actual cost and the estimate by the Cutter Suction Dredge Cost Estimating Program was 10 percent absolute difference. The average difference between the government estimates and the winning bids was 18 percent absolute difference. This is comparable, especially because two of the government's bids were the same as the winning bids. No data were available for the

bank height, sediment type, or pipeline length, estimates were made for these and default parameters were used in the spreadsheet.

Four beach nourishment projects were among the sixteen chosen projects, two in the Gulf of Mexico, one in New York, and one in New Jersey. The average difference between government estimates and the winning bids for the beach nourishment projects were 25% absolute difference. The Cutter Suction Dredge Cost Estimating Program (CSDCEP) calculated the average difference as 9% by considering much longer pipelines, increased labor costs, and increased equipment costs.

As technology and information increases the Cutter Suction Dredge Cost Estimating Program can become more accurate. The cost estimating data can be updated every five years as a base to ensure the costs are current and reflect up to date economic information. The beneficial use section can be expanded to include not only beach nourishment projects but also habitat creation, restoration, agriculture reuse, bird islands, or nesting areas. Another option to include in the Cutter Suction Dredge Cost Estimating Program is the addition of contaminated sediment removal and the additional costs associated with hazardous material removal.

This thesis focused on the Cutter Suction Dredge Cost Estimating Program by updating and improving the existing software. The new program includes cost estimates for beach nourishment projects, ladder pump or booster pump estimates, improved calculations if the

pipeline is on an incline, and improvements to the non-dimensional pump curves for more accurate representation of the cutter suction dredge size chosen.

As described previously, the Cutter Suction Dredge Cost Estimating Program (CSDCEP) estimates the production rate, the cost of cutter suction dredge projects, and projected time to complete a dredging project. This program is non-proprietary and can be used by the public, government, or even contractors to accurately estimate dredging projects. The CSDCEP is a generalized program to estimate cost since access to specific dredge characteristics or site properties is not always available to either the bidding contractors or the government. With the generalized program, a user can still accurately estimate the cost within a varying degree of certainty. This program may not be as accurate as the contractors who have their own programs with the specifics of their equipment. While some inaccuracy is unavoidable, some of the uncertainty can be minimized by the user entering defaults, and specifications that are known, or making estimates for others.

## REFERENCES

- Adair, R.F. (2004). "Estimating Production and Cost for Clamshell Mechanical Dredges." M.S. Thesis, Texas A&M University, College Station, TX.
- Asker, M. Turgut, O. E., Coban, M. T., (2014). "A Review of Non Iterative Friction Factor Correlations for the Calculation of Pressure Drop in Pipes." *Bitlis Eren Univ J Sci & Technol* 4(1), pp 1-8.
- Auger, C. (2012). "Update to Cost and Production Estimation for Cutter Suction Dredge." Texas A&M University, College Station, Texas.
- Barfuss, Steven L. and Tullis, J. Paul, (1988). "Friction Factor Tests on High Density Polyethylene Pipe." Paper 612
- Bray, R.N., Bates, A.D., and Land J.M. (1997). "Dredging a Handbook for Engineers." 2<sup>nd</sup> Edition. John Wiley & Sons, Inc., New York, NY.
- Center for Dredging Studies (CDS), (2015). "Cost Estimating Spreadsheet." Department of Ocean Engineering. Texas A&M University, College Station, Texas.
- Cheng, N.S. (1997). "Simplified Settling Velocity Formula for Sediment Particle." *J. Hydr. Engr. Div., ASCE*, 123 (2), pp 149-152.
- Colebrook C. F., White, C. M. (1937). "Experiments with Fluid Friction Roughened Pipes." *Proc R Soc (A)*, pp 161.
- Hartman, M., Trnko, O., and Svoboda, K. (1994). "Free Settling of Non-spherical Particles." *Ind. Eng. Chem. Res.*, 33(8), pp 1979-1983.
- Herbich, J. B. (2000). "Handbook of Dredging Engineering." Second Edition, McGraw-Hill, New York, NY.
- Hi-Sea Marine (2018). "Marine Equipment Suppliers and Manufactures-Hi-Sea Marine." [<http://www.hiseamarine.com/>]. Chongqing, China.
- Hollinberger, T.E. (2010). "Cost Estimation and Production Evaluation for Hopper Dredges." M.S. Thesis, Texas A&M University, College Station, TX.
- Jin, C. & Randall, R. E. (2018). "The Estimation of Production and Location of Pumps for a Cutter Suction Dredge using a Long Distance Pipeline." *Western Dredging Association Journal of Dredging*, Vol 16, No. 1, Las Vegas, NV, USA, pp. 24-42.



- Kundu, P. K., Cohen, I. M., and Dowling, D. R., (2016). "Fluid Mechanics." Academic Press, San Diego, CA.
- Matousek, V. (1997). "Flow Mechanism of Sand-water Mixtures in Pipelines." PhD Dissertation, Delft University of Technology, Delft, Netherlands
- Miedema, S.A. (2016). "Slurry Transport Fundamentals, A Historical Overview & The Delft Head Loss and Limit Deposit Velocity Framework." Dr.ir. S.A. Miedema (SAM-Consult).
- Miertschin, M.W. (1997). "Cost and Production Estimation for a Cutter Suction Dredge." M.S. Thesis, Texas A&M University, College Station, TX.
- Miertschin, M. and Randall, R. E. (1998). "A General Cost Estimation Program for Cutter Suction Dredges." *Proceedings of 15<sup>th</sup> World Dredging Congress*, Las Vegas, NV, USA, pp. 1099-1115, June 28 – July 2.
- Moody, L. F. (1944). "Friction Factors for Pipe Flow." *Trans., America Society of Mechanical Engineers*, vol 66.
- Navigation Data Center (NDC) (2018). "Dredging Program." [<http://www.navigationdatacenter.us/dredge/dredge.htm>]. Unites States Army Corps of Engineers, Alexandria, VA.
- Paparis, N. A. (2017). "Clamshell Mechanical Dredge Production and Cost Estimation." M.S. Thesis, Texas A&M University, College Station, TX.
- Performance Pipe (2018). "Chevron Phillips Chemical Company." [<http://www.performancepipe.com/en-us/Pages/default.aspx>]. Plano, TX.
- Randall, R. E. (2000). "Estimating Dredging Costs." Appendix 9, *Handbook of Dredging Engineering*, Editor: J.B. Herbich, Second Edition, McGraw-Hill Book Co., New York, NY
- Randall, R. E. (2004). "Dredging." Chapter 11, *Port Engineering: Planning, Construction, Maintenance, and Security*, Editor: G. P. Tsinker. John Wiley & Sons, Inc, Hoboken, NJ.
- Randall, R. E. and Yeh, P. (2013). "Estimating Dredge Production and Booster Pump Location." *Proceedings of the World Dredging Congress XIX*, Brussels, Belgium, June 3-6,
- Randall, R.E. (2017). "Dredging and Dredged Material Placement." Center for Dredging Studies, Department of Ocean Engineering, Texas A&M University, College Station, TX.

- RSMMeans Company Inc. (2018). "Heavy Construction Cost Data." 29th Annual Edition. RSMMeans Construction Publishers & Consultants., Norwell, MA.
- Schiller, R.E. (2000). "Sediment Transport in Pipes." Chapter 6. Handbook of Dredging Engineering, Herbich Editor, Second Edition, McGraw-Hill, Inc, New York, NY, pp 6.39-6.54.
- Swamee, D. K. and Jain, A. K. (1976). "Explicit Equations for Pipe Flow Problems." *Journal of Hydraulics Division* 102, pp. 657-644.
- Swamee, P. K. and Ojha, C. S. (1991). "Drag Coefficient and Fall Velocity of Non-spherical Particles." *J. Hydr. Engr. Div., ASCE 117(5)*, pp 660-667.
- Turner, T.M. (1996). "Fundamentals of Hydraulic Dredging." 2<sup>nd</sup> Edition. American Society of Civil Engineers Press.
- U.S. Bureau of Labor Statistics (2017). "Overview of BLS Wage Data by Area and Occupation." [<http://www.bls.gov/bls/blswage.htm>]. United States Department of Labor, Washington, D.C.
- U.S. Energy Information Administration (2018). "Petroleum & Other Liquids." [<http://www.eia.gov/petroleum/gasdiesel/>]. U.S. Department of Energy, Washington, D.C.
- Volk, M. (2014). "Pump Characteristics and Applications." 3<sup>rd</sup> Edition. Taylor & Francis Group., Boca Raton, FL.
- Wilson, K. C., & Tse, J. K. P. (1984). "Deposition Limit for Coarse Particle Transport in Inclined Pipes." *In Proceedings of the 9<sup>th</sup> International Conference on the Hydraulic Transport of Solids in Pipes*, Cranfield, England, pp. 149-161.
- Wilson, K.C., Addie, G.R., Sellgren, A., and Clift, R. (2006). "Slurry Transport Using Centrifugal Pumps." 3<sup>rd</sup> Edition, Elsevier Applied Science, New York, NY.
- Wowtschuk, B.M. (2016). "Production and Cost Estimating for a Trailing Suction Hopper Dredge." M.S. Thesis, Texas A&M University, College Station, TX.

## **APPENDIX A**

### **USER'S MANUAL**

The user's manual for the Cutter Suction Dredge Cost Estimating Program is designed to provide the operator a guide for the program, starting with data entry and ending with an analysis of the final results. This program estimate is non-proprietary and is made for anyone in the public to use. The user's manual will ensure the public knows how to use the program to its full potential.

#### **Organization**

The program is divided into nine sections: data input, defaults, mobilization and demobilization (mob), execution, critical velocity ( $V_c$ ), database, production, head loss, and net positive suction head (NPSH). The user can input specific values and data in the program cells that are highlighted in green. The program cells that are highlighted in yellow are the final results calculated by the spreadsheet. Each page of the program has links to the other pages for easy access through the program. Most of the user input is located in the first two sections: data input and defaults.

#### **Data Input**

The data input tab labeled "Data Input CS" is the first section of the program, as well as the most importation section for the user. Here, the operator will input information based on the specific dredging project. Minimally, the user should input the year, dredge size (inches), and quantity to be dredged (cubic yards).

### ***Year***

The year should be entered for the year of the project, the year will affect the final mobilization and demobilization cost and the final cost due to inflation.

### ***Dredge size***

The dredge size is the size of the dredge used in the specific dredging project. The dredge size is measured by the diameter of the discharge pipeline, and measured in inches. The values for typical dredge sizes are shown in a dropdown menu and range from 8 inches to 32 inches.

### ***Quantity to be dredged***

The quantity to be dredged is the volume of material that will be removed, and is measured in cubic yards.

### **Additional Data Inputs**

There are additional inputs in the data input tab, the more information that the user knows and can enter, the more accurate the program cost estimate will be. Some additional inputs include, bank height, digging depth, fuel cost, maximum pumping distance, average pumping distance, percentage floating, submerged, and shore pipeline, beach nourishment pipeline, number of boosters, production override, and sediment type.

| Main Inputs                    |         |            |         |         |
|--------------------------------|---------|------------|---------|---------|
| Year                           | 2018    |            |         |         |
| Dredge size (D <sub>d</sub> ): | 30      | in         |         |         |
| Quantity to be dredged:        | 1000000 | cy         |         |         |
| Bank Height:                   | 5       | ft         |         |         |
| Digging Depth:                 | 12      | ft         |         |         |
| Fuel Cost:                     | \$2.50  | per gallon |         |         |
| Max Pumping Distance:          | 5000    | ft         |         |         |
| Avg Pumping Distance:          | 5000    | ft         | Average | Reserve |
| % Floating Pipeline:           | 10      | →          | 200     | 0       |
| % Submerged Pipe:              | 0       | →          | 0       | 0       |
| % Shore Pipe:                  | 90      | →          | 1800    | 0       |
| Beach Nourishment Pipeline     | 2000    | ft         |         |         |
| Number of Boosters:            | 2       |            |         |         |
| Additional Boosters?           | No      |            |         |         |
| Ladder Pump Required?          | No      |            |         |         |
| Production Rate:               | 4374    | cy/hr.     |         |         |
| Production Override:           | 0       | cy/hr.     |         |         |
| Sediment Type                  |         |            |         |         |
| Material                       | Percent | SG         | Factor  |         |
| Mud and Silt                   | 0.00%   | 1.2        | 3       |         |
| Mud and Silt                   | 90.00%  | 1.3        | 2.5     |         |
| Mud and Silt                   | 0.00%   | 1.4        | 2       |         |
| Loose Sand                     | 0.00%   | 1.7        | 1.1     |         |
| Loose Sand                     | 10.00%  | 1.9        | 1       |         |
| Comp. Sand                     | 0.00%   | 2          | 0.9     |         |
| Stiff Clay                     | 0.00%   | 2          | 0.6     |         |
| Comp. Shell                    | 0.00%   | 2.3        | 0.5     |         |
| Soft Rock                      | 0.00%   | 2.4        | 0.4     |         |
| Blasted Rock                   | 0.00%   | 2          | 0.25    |         |

Figure A1: Main Input Section

***Bank height***

The bank height is the average depth of cut made into the channel.

***Digging depth***

Digging depth is the depth of the area to be dredged.

***Fuel cost***

The current cost of diesel fuel per gallon. The user can leave the default value or add values as needed.

***Maximum pumping distance***

The maximum length of pipe used. This adds to the cost of the pipeline due to material cost, and mobilization and demobilization costs.

***Average pumping distance***

The average pumping distance is the average length of pipe through which the dredged material travels to the dredging placement site. This number is used for production rates, boosters, cost of pipeline, and mobilization and demobilization costs.

***Percentage floating, submerged, and shore pipeline***

The percentage of floating, submerged, and shore pipeline are the amounts of each length of pipeline. The cost is more expensive with more floating and submerged pipelines. The user can add exact lengths or leave the defaults in place.

***Beach nourishment pipeline***

Beach nourishment pipeline can be added if the dredging project is in combination with beneficial use and the dredging material is being used for beach nourishment. If known the additional length of shore pipeline for the beach nourishment can be added here. This number

will only be included in the final cost estimate if the beach nourishment option is included on the Defaults tab.

### ***Number of boosters***

The number of boosters section lets the user add additional booster pumps. Booster pumps are needed if the pipeline length is too long for the main pump to maintain the velocity. The additional booster output block will let the user know if another booster pump is required for the dredging job. If another booster pump is needed the user can increase the number of boosters manually until the additional boosters needed output block says “No”. The user can vary the number of boosters and determine the optimum booster pump number by observing the effect on the final cost estimate.

### ***Ladder pump***

The cost estimating program determines the net positive suction head (NPSH) for the dredging project in the tab labeled NPSH. If the main pump shows it will cavitate a ladder pump will be added to the estimate and the user can see if one is required on the data input page.

### ***Production***

The cost estimating program calculates the production by determining the discharge rate from the entered dredge size. If the user wishes to enter a specific production rate they can add it to the production override block to bypass the program’s estimate.

### ***Sediment type***

If the sediment type is known for a specific project the user can add material percentages. These percentages are used to calculate the specific gravity (SG) of the sediment. If sediment analysis has not been conducted, the user can estimate or leave the defaults percentages in place. There

are ten different sediment types listed with specific gravities ranging from 1.2 for mud and silt to 2 for rock. Mud and silt will obviously be much easier to pump than rock, so if the sediment type can be estimated a better cost estimate will be obtained.

### **Final Cost Estimate**

The final cost estimate results are also displayed on the Data Input tab. The results are highlighted in yellow and include the total cost of the project, the cost per hour, cost per cubic yard, and time required to complete the dredging job. The total cost of the project includes the cost index for the chosen year, and a regional index for the chosen project location, located in the defaults tab. Daily costs are broken down by crew, equipment, pipeline, and overhead costs. The total mobilization and demobilization cost is listed as well and can be added to the total cost by the user's choice.



| <b>Final Cost Estimate - Year 2018</b> |                            |  |
|--|----------------------------|--|
| Total Cost of Project:                 | \$3,802,561.19             |  |
| Cost per Hour                          | \$5,969.44 per hour        |  |
| Cost per Yard <sup>3</sup>             | \$3.80 per yd <sup>3</sup> |  |
| Time Required:                         | 0.9 Months                 |  |
|  |                            |  |
|  |                            |  |
| Crew Cost:                             | \$23,955.60 per day        |  |
| Equipment Costs:                       | \$46,679.93 per day        |  |
| Pipeline Costs:                        | \$403.19 per day           |  |
| Overhead Costs:                        | \$6,393.48 per day         |  |
| Additional Costs:                      | \$55,000.00 per day        |  |
| Total Cost of Execution:               | \$132,432.21 per day       |  |
|  |                            |  |
| Contractor's Profit                    | 9.00%                      |  |
| Contractor's Bond                      | 1.00%                      |  |
|  |                            |  |
| Total Mob/Demob Cost:                  | \$224,088.23               |  |
| Include in Total Cost?                 | Yes                        |  |

**Figure A2: Main Output Section**

### Defaults

The Defaults tab in the Cutter Suction Dredge Cost Estimating Program is the next most important tab for the user. The default section lists important values and costs typical for the current equipment, industry, and economy. Figure A3 shows the defaults page of the Cutter Suction Dredge Cost Estimating Program. The first column includes all the default numbers and the green column has the values being used by the cost estimating program. The user can leave the values as default or add specific values if known. Most of the values will not need to be altered or changed, but can be in the future if an update is required. The defaults page is divided

into five categories: general, mobilization and demobilization, crew rates, execution, and production.

### ***General***

The general section includes crew shift duration, number of shifts per day and region of the country the project is located in. The cost estimating project applies a cost index depending on the region selected. The user has a choice from a dropdown list including: Alaska/Hawaii, East Coast, Great Lakes, West Coast, or No Region Index.

### ***Mobilization and demobilization***

The cost estimating program determines the mobilization and demobilization estimate from one of three options. The drop-down menu includes historical trend, Bray, Bates and Land, or manual entry. The historical trend uses historical data based on the median value of the mobilization and demobilization cost estimates from the ten most recent dredging projects from the U.S. Army Corps of Engineers trends. The Bray, Bates, and Land method is from a method from the book *Dredging-A handbook for engineers (1997)* by Bray, Bates, and Land. Since Bray, Bates, and Land developed their estimate in 1997 the cost estimating program adds a cost index to the final estimate if the user wishes to choose the final estimate from Bray, Bates, and Land. The third method allows the user to add the mobilization and demobilization costs manually with a link to manual entry where the values can be inputted.

### ***Crew rates***

The crew rates include merchant mariners on the dredge as well as dredge specific workers. The hourly rates are from RSMMeans Heavy Construction Cost Data 2018.

### ***Execution***

Included in the Execution section is the disposal method. The drop-down menu includes, upland, open water, or beach nourishment for the three dredging placement sites.

### ***Production***

The production section includes options for production estimate, type of dredge, method for calculation critical velocity and an option to enter the pump characteristics curves manually. The default method to calculate production is using the cost estimating programs formulas, the other method was developed by the U. S. Army Corps of Engineers. There are two options for type of dredge, fixed spud or spud carriage. The dredging efficiency is 50% when using fixed spuds or 75% when using a spud carriage. There are two methods to calculate the critical velocity located in the  $V_c$  tab of the spreadsheet. The first is using Matousek equation:

$$V_c = \frac{8.8 \left[ \frac{\mu_s (S_s - S_f)}{0.66} \right]^{0.55} D^{0.7} d_{50}^{1.75}}{d_{50}^2 + 0.11D^{0.7}} \quad (1)$$

where  $\mu_s$  is the coefficient of mechanical friction between the solid particles, and the pipe wall, usually equal to 0.44,  $S_s$  is the specific gravity of solids,  $S_f$  is the specific gravity of fluid,  $d_{50}$  is the median grain diameter (mm), and  $D$  is the inside pipe diameter (m).

The second method is to use the nomograph Wilson et al. (2006). The cost estimating spreadsheet uses an interpolation from the nomograph used to estimate the critical velocity of the slurry in the pipeline. There is also an option for the user to enter a pipe inclination. Critical velocity increases as the angle between the pipe and horizontal increases up to an angle of 35

degrees. The user can also elect to enter the pump characteristics manually. The cost estimating program will use a dimensionless pump curve if the characteristics are not known. If the user has specific pump information, they can select the link labeled “Link to Manual Entry” which will take the user to the manual entry section in the Production tab.

|            | Default Value        | Chosen Value         | Units   | Description  |
|------------|----------------------|----------------------|---|--|
| General    | 8                    | 8                    | hrs./day  | Crew shift duration  |
|            | 3                    | 3                    | /day  | Number of shifts per day                                     |
|            | Gulf Coast           | Gulf Coast           |   | Region   |
| Mob/Demob  | Bray, Bates and Land | Bray, Bates and Land |   | Method for estimating mobilization and demobilization costs  |
|            | 200                  | 200                  | /day  | Supplies and small tools                                     |
|            | 600                  | 600                  | /day  | Support equipment with operators                             |
|            | 200                  | 200                  | /day  | Fuel (plant idle)  |
|            | 25                   | 25                   | /man /day   | Subsistence  |
|            | 100                  | 100                  | miles/day   | Towing speed   |
|            | 4000                 | 4000                 | /day  | Towing vessel cost   |
|            | 1                    | 1                    |   | Number of vessels  |
|            | 150                  | 150                  | /man  | Travel expenses  |
|            | 200                  | 200                  | /day  | Local hire   |
|            | 1                    | 1                    | Days  | Demob time required to prepare dredge for transfer from site |
|            | 20                   | 20                   | Miles   | Demobilization transfer all from site Distance               |
|            | 1                    | 1                    | Days  | Demobilization time to Prepare Dredge for Storage            |
|            | 1                    | 1                    | Days  | Demobilization time to Prepare Pipeline for Storage          |
|            | \$0.00               | \$0.00               | dollars   | Demobilization other lump sum cost                           |
|            | 20                   | 20                   | Miles   | Mobilization transfer to site distance                       |
|            | 3                    | 3                    | men/shift   | Mobilization transfer to site crew size                      |
| 1          | 1                    | Days                 | Mobilization Time Required to Prepare Dredge for work at site |  |
| \$0.00     | \$0.00               | dollars              | Mobilization other lump sum cost                              |  |
| Crew Rates | \$ 62.00             | \$ 62.00             | /hour   | Master   |
|            | \$ 51.00             | \$ 51.00             | /hour   | Assistant Master   |
|            | \$ 35.00             | \$ 35.00             | /hour   | Mates (2 <sup>nd</sup> or 3 <sup>rd</sup> )                  |
|            | \$ 61.00             | \$ 61.00             | /hour   | Chief Engineer   |
|            | \$ 37.00             | \$ 37.00             | /hour   | Assistant Chief Engineer                                     |
|            | \$ 35.00             | \$ 35.00             | /hour   | Assistant Engineer (2 <sup>nd</sup> or 3 <sup>rd</sup> )     |
|            | \$ 31.00             | \$ 31.00             | /hour   | Marine Electrician   |
|            | \$ 26.00             | \$ 26.00             | /hour   | Marine Oiler   |
|            | \$ 30.00             | \$ 30.00             | /hour   | Electronics Mechanic   |
|            | \$ 39.60             | \$ 39.60             | /hour   | Foreman  |
|            | \$ 43.60             | \$ 43.60             | /hour   | Leverman   |
|            | \$ 34.35             | \$ 34.35             | /hour   | Laborer  |
|            | \$ 48.60             | \$ 48.60             | /hour   | Equipment Operator   |
| \$ 40.30   | \$ 40.30             | /hour                | Cook  |  |
| 9%         | 9%                   |                      | Overhead  |  |
| Execution  | Upland               | Upland               |   | Disposal Method  |
|            | 300                  | 300                  | days/year   | Days per year dredge is in use                               |
|            | 15.6                 | 15.6                 | hrs./day  | Dredge operating at 100%                                     |
| Production | CSDCEP               | CSDCEP               |   | Method for production estimate                               |
|            | 10                   | 10                   |   | Discharge lift (ft)  |
|            | 44                   | 44                   |   | Ladder length (ft)   |
|            | 1.025                | 1.025                |   | Specific gravity of surrounding water                        |
|            | 0.1                  | 0.1                  |   | K for ball joints  |
|            | 1.9                  | 1.9                  |   | K for swivel joints  |
|            | 1.6                  | 1.6                  |   | K for head losses at suction                                 |
|            | 0.5                  | 0.5                  |   | K for head losses at discharge                               |
|            | 0.3                  | 0.3                  |   | K for elbows   |
|            | 1.35                 | 1.35                 |   | Maximum possible SG of slurry                                |
|            | 1.2                  | 1.2                  |   | Minimum allowable SG of slurry                               |
|            | 5                    | 5                    |   | Percent of total system head that must be greater than Hp-HL |
|            | Spud Carriage        | Spud Carriage        |   | Type of Dredge   |
|            | No                   | No                   |   | Enter pump characteristics curves manually?                  |
|            | 0.4                  | 0.4                  | mm  | d <sub>50</sub>  |
|            | 2.1                  | 2.1                  |   | SG Solids  |
|            | 0.00015              | 0.00015              | feet  | Pipe Roughness   |
| 0.00000117 | 0.00000117           |                      | Kinematic Viscosity   |  |
| 0.0012     | 0.0012               |                      | Dynamic Viscosity   |  |
| 0          | 0                    |                      | Pipe Inclination  |  |
| Matousek   | Matousek             |                      | Method for calculating V <sub>c</sub>                         |  |

Figure A3: Defaults Page

## **Calculations**

The cost estimating program runs as soon as it is open. When any value is changed the outputs also updates immediately. Since the calculation time is short, estimates can be developed very quickly. The rest of the spreadsheet is divided to run the final cost estimate. While the user will not need to enter any or change any inputs in these tabs, they might want to find some specific information or explore the program to understand how the estimate is calculated.

## **Mobilization/Demobilization (Mob)**

The Mobilization tab is where the mobilization and demobilization costs are estimated. The user can manually enter mobilization and demobilization costs or use the estimate provided by the program. The three sections in this tab are for mobilization costs, demobilization costs, and total estimates. Included in the mobilization and demobilization costs are the time, distances, and crew sizes for the dredge to transit to and from the dredging site. In the total estimate section are the totals for using the historical trend method, Bray, Bates, and Land method, or the manual entry.

## **Execution**

On the Execution tab the user can see the project execution estimate and the different methods for estimating production. This section has six sections, total costs, production, crew, equipment, pipeline, and additional daily costs. The total cost section includes the total cost estimate from production, as well as the daily costs for equipment, crew, pipeline, and overhead. The time required to dredge in months is also included. The production section includes the production estimate calculated from the spreadsheet, and the total production estimate from the U. S. Army Corps of Engineers estimate. The crew and equipment section both show the amount of crew or equipment needed depending on the dredging project. The user can add additional crew or

equipment costs here as well. The final section is for additional daily costs. The user can add additional costs if needed. If the disposal method chosen is beach nourishment, then the environmental protection, and monitor surveys will automatically be added to the total cost.

### **Data Base**

The Data Base section allows user to view the database that the program uses to develop all the estimates and values for the program. The user should not edit anything in this tab.

### **Production**

The user can view the production outputs from the Production tab. This tab also includes the dimensionless pump curves as well as the manual entry for the user to enter specific pump characteristics. The dimensionless pump equations determine the dimensionless flowrate, head, power, and efficiency.

### **Head Loss**

In the Head Loss tab the user can view the calculations for head loss in the pipeline due to friction. Minor losses due to pipe joints and bends are also calculated here. In this section the user can view the total system curve which includes the system head curve, pump head curve, optimal flow rate, and critical flow rate. There is nothing for the user to edit in this tab.

### **Critical Velocity ( $V_c$ )**

The Critical Velocity tab includes the calculations for critical velocity of the slurry in the pipeline. The two methods of calculating critical velocity are from Wilson et al. (2006) nomograph, and from the Matousek equation. The user can compare the two methods in this section, but there is nothing for the user to edit in this tab.

## **Net Positive Suction Head (NPSH)**

The NPSH tab of the Cutter Suction Dredge Cost Estimating Program is to determine the Net Positive Suction Head and if the pump will cavitate. If the pump cavitates, the program will add a ladder pump to the estimate. The user can view the NPSH calculations but there is nothing to edit on this tab.

## **Example**

One example project was chosen for the year 2018, with a 30 in dredge size, and 1,000,000 cubic yards of sediment to be dredged. Figure A4 shows the Cutter Suction Dredge Cost Estimating Program data input for this particular example. In addition to the year, dredge size, and quantity to be dredged, the user chose a bank height of 5 feet and a sediment type of 75% loose sand and 25% mud and silt. The program suggested only one booster pump with no additional booster pumps required, and no ladder pump required.



| Main Inputs                    |         |            |         |         |
|--------------------------------|---------|------------|---------|---------|
| Year                           | 2018    |            |         |         |
| Dredge size (D <sub>d</sub> ): | 30      | in         |         |         |
| Quantity to be dredged:        | 1000000 | cy         |         |         |
| Bank Height:                   | 5       | ft         |         |         |
| Digging Depth:                 | 12      | ft         |         |         |
| Fuel Cost:                     | \$3.50  | per gallon |         |         |
| Max Pumping Distance:          | 5000    | ft         |         |         |
| Avg Pumping Distance:          | 5000    | ft         | Average | Reserve |
| % Floating Pipeline:           | 10      | →          | 500     | 0       |
| % Submerged Pipe:              | 0       | →          | 0       | 0       |
| % Shore Pipe:                  | 90      | →          | 4500    | 0       |
| Beach Nourishment Pipeline     | 11000   | ft         |         |         |
| Number of Boosters:            | 1       |            |         |         |
| Additional Boosters?           | No      |            |         |         |
| Ladder Pump Required?          | No      |            |         |         |
| Production Rate:               | 1533    | cy/hr.     |         |         |
| Production Override:           | 0       | cy/hr.     |         |         |
| Sediment Type                  |         |            |         |         |
| Material                       | Percent | SG         | Factor  |         |
| Mud and Silt                   | 0.00%   | 1.2        | 3       |         |
| Mud and Silt                   | 0.00%   | 1.3        | 2.5     |         |
| Mud and Silt                   | 25.00%  | 1.4        | 2       |         |
| Loose Sand                     | 0.00%   | 1.7        | 1.1     |         |
| Loose Sand                     | 75.00%  | 1.9        | 1       |         |
| Comp. Sand                     | 0.00%   | 2          | 0.9     |         |
| Stiff Clay                     | 0.00%   | 2          | 0.6     |         |
| Comp. Shell                    | 0.00%   | 2.3        | 0.5     |         |
| Soft Rock                      | 0.00%   | 2.4        | 0.4     |         |
| Blasted Rock                   | 0.00%   | 2          | 0.25    |         |

Figure A4: Example Input Data

|            | Default Value        | Chosen Value         | Units   | Description  |
|------------|----------------------|----------------------|---|--|
| General    | 8                    | 8                    | hrs./day  | Crew shift duration  |
|            | 3                    | 3                    | /day  | Number of shifts per day                                     |
|            | Gulf Coast           | Gulf Coast           |   | Region   |
| Mob/Demob  | Bray, Bates and Land | Bray, Bates and Land |   | Method for estimating mobilization and demobilization cost   |
|            | 200                  | 200                  | /day  | Supplies and small tools                                     |
|            | 600                  | 600                  | /day  | Support equipment with operators                             |
|            | 200                  | 200                  | /day  | Fuel (plant idle)  |
|            | 25                   | 25                   | /man /day   | Subsistence  |
|            | 100                  | 100                  | miles/day   | Towing speed   |
|            | 4000                 | 4000                 | /day  | Towing vessel cost   |
|            | 1                    | 1                    |   | Number of vessels  |
|            | 150                  | 150                  | /man  | Travel expenses  |
|            | 200                  | 200                  | /day  | Local hire   |
|            | 1                    | 1                    | Days  | Demob time required to prepare dredge for transfer from site |
|            | 20                   | 20                   | Miles   | Demobilization transfer all from site Distance               |
|            | 1                    | 1                    | Days  | Demobilization time to Prepare Dredge for Storage            |
|            | 1                    | 1                    | Days  | Demobilization time to Prepare Pipeline for Storage          |
|            | \$0.00               | \$0.00               | dollars   | Demobilization other lump sum cost                           |
|            | 20                   | 20                   | Miles   | Mobilization transfer to site distance                       |
| 3          | 3                    | men/shift            | Mobilization transfer to site crew size                       |  |
| 1          | 1                    | Days                 | Mobilization Time Required to Prepare Dredge for work at site |  |
| \$0.00     | \$0.00               | dollars              | Mobilization other lump sum cost                              |  |
| Crew Rates | \$ 62.00             | \$ 62.00             | /hour   | Master   |
|            | \$ 51.00             | \$ 51.00             | /hour   | Assistant Master   |
|            | \$ 35.00             | \$ 35.00             | /hour   | Mates (2 <sup>nd</sup> or 3 <sup>rd</sup> )                  |
|            | \$ 61.00             | \$ 61.00             | /hour   | Chief Engineer   |
|            | \$ 37.00             | \$ 37.00             | /hour   | Assistant Chief Engineer                                     |
|            | \$ 35.00             | \$ 35.00             | /hour   | Assistant Engineer (2 <sup>nd</sup> or 3 <sup>rd</sup> )     |
|            | \$ 31.00             | \$ 31.00             | /hour   | Marine Electrician   |
|            | \$ 26.00             | \$ 26.00             | /hour   | Marine Oiler   |
|            | \$ 30.00             | \$ 30.00             | /hour   | Electronics Mechanic   |
|            | \$ 39.60             | \$ 39.60             | /hour   | Foreman  |
|            | \$ 43.60             | \$ 43.60             | /hour   | Leverman   |
|            | \$ 34.35             | \$ 34.35             | /hour   | Laborer  |
|            | \$ 48.60             | \$ 48.60             | /hour   | Equipment Operator   |
| \$ 40.30   | \$ 24.00             | /hour                | Cook  |  |
| 9%         | 9%                   |                      | Overhead  |  |
| Execution  | Upland               | Upland               |   | Disposal Method  |
|            | 300                  | 300                  | days/year   | Days per year dredge is in use                               |
|            | 15.6                 | 15.6                 | hrs./day  | Dredge operating at 100%                                     |

Figure A5: Example Default Values

|            |               |            |                                       |  |
|------------|---------------|------------|---------------------------------------|--|
| Production | CSDCEP        | CSDCEP     |                                       | Method for production estimate                           |
|            | 10            | 10         |                                       | Discharge lift (ft)                                      |
|            | 44            | 21         |                                       | Ladder length (ft)                                       |
|            | 1.025         | 1.025      |                                       | Specific gravity of surrounding water                    |
|            | 0.1           | 0.1        |                                       | K for ball joints  |
|            | 1.9           | 1.9        |                                       | K for swivel joints                                      |
|            | 1.6           | 1.6        |                                       | K for head losses at suction                             |
|            | 0.5           | 0.5        |                                       | K for head losses at discharge                           |
|            | 0.3           | 0.3        |                                       | K for elbows   |
|            | 1.35          | 1.35       |                                       | Maximum possible SG of slurry                            |
|            | 1.2           | 1.2        |                                       | Minimum allowable SG of slurry                           |
|            | 5             | 5          |                                       | Percent of total system head that must be greater than H |
|            | Spud Carriage | Fixed Spud |                                       | Type of Dredge   |
|            | No            | No         |                                       | Enter pump characteristics curves manually?              |
|            | 0.4           | 0.4        | mm                                    | d <sub>50</sub>  |
|            | 2.1           | 2.1        |                                       | SG Solids  |
|            | 0.00015       | 0.00015    | feet                                  | Pipe Roughness   |
|            | 0.00000117    | 0.00000117 |                                       | Kinematic Viscosity                                      |
| 0.0012     | 0.0012        |            | Dynamic Viscosity                     |  |
| 0          | 0             |            | Pipe Inclination                      |  |
| Matousek   | Matousek      |            | Method for calculating V <sub>c</sub> |  |

**Figure A6: Example Default Production Values**

Figures A5 and A6 show the example default value page. For this example, the Gulf Coast is the region of the dredging project, with an upland disposal method, and a fixed spud dredge. Figure A7 shows the final cost estimate from the Cutter Suction Dredge Cost Estimating Program after the input and defaults were entered. The total cost of the project will be \$5,458,387.90 and can be completed in 2.5 months.

| <b>Final Cost Estimate - Year 2018</b> |                    |                     |
|--|--------------------|---------------------|
| Total Cost of Project:                 | \$5,458,397.90     |                     |
| Cost per Hour                          | \$3,003.21         | per hour            |
| Cost per Yard <sup>3</sup>             | \$5.46             | per yd <sup>3</sup> |
| Time Required:                         | 2.5                | Months              |
|  |                    |                     |
| Crew Cost:                             | \$21,820.80        | per day             |
| Equipment Costs:                       | \$46,653.59        | per day             |
| Pipeline Costs:                        | \$516.42           | per day             |
| Overhead Costs:                        | \$6,209.17         | per day             |
| Additional Costs:                      | \$0.00             | per day             |
| <b>Total Cost of Execution:</b>        | <b>\$75,199.98</b> | <b>per day</b>      |
|  |                    |                     |
| Contractor's Profit                    | 0.00%              |                     |
| Contractor's Bond                      | 0.00%              |                     |
|  |                    |                     |
| Total Mob/Demob Cost                   | \$209,193.58       |                     |
| Include in Total Cost?                 | Yes                |                     |

**Figure A7: Example Final Cost Estimate**