



(12) **United States Patent**
Holtzapple et al.

(10) **Patent No.:** **US 8,753,099 B2**
(45) **Date of Patent:** **Jun. 17, 2014**

(54) **SEALING SYSTEM FOR GEROTOR APPARATUS**

(56) **References Cited**

(75) Inventors: **Mark T. Holtzapple**, College Station, TX (US); **George A. Rabroker**, College Station, TX (US); **Michael K. Ross**, Bryan, TX (US)

U.S. PATENT DOCUMENTS
457,294 A 8/1891 Tilden
724,665 A 4/1903 Cooley
892,295 A 6/1908 Nutz
1,501,051 A 7/1924 Hill
1,854,692 A 4/1932 Cooper
2,011,338 A 8/1935 Hill

(73) Assignees: **The Texas A&M University System**, College Station, TX (US); **Starrotor Corporation**, College Station, TX (US)

(Continued)

(*) Notice: Subject to any disclaimer, the term of this patent is extended or adjusted under 35 U.S.C. 154(b) by 141 days.

FOREIGN PATENT DOCUMENTS

AU 20406/29 12/1929
DE 35 13348 10/1986

(Continued)

(21) Appl. No.: **12/978,220**

(22) Filed: **Dec. 23, 2010**

(65) **Prior Publication Data**

US 2011/0200476 A1 Aug. 18, 2011

Related U.S. Application Data

(63) Continuation of application No. 11/041,011, filed on Jan. 21, 2005, now abandoned.

(60) Provisional application No. 60/538,747, filed on Jan. 23, 2004.

(51) **Int. Cl.**

F03C 2/00 (2006.01)

F03C 4/00 (2006.01)

F04C 2/00 (2006.01)

(52) **U.S. Cl.**

USPC **418/141**; 418/104; 418/140; 418/171; 277/303; 277/412

(58) **Field of Classification Search**

USPC 418/61.3, 104, 125, 140-141, 143, 166, 418/171; 277/303, 358, 412, 415

See application file for complete search history.

OTHER PUBLICATIONS

PCT Notification of Transmittal of the International Search Report and the Written Opinion of the International Searching Authority, or the Declaration dated Aug. 16, 2007.

(Continued)

Primary Examiner — Theresa Trieu

(57) **ABSTRACT**

According to one embodiment of the invention, a gerotor apparatus includes a first gerotor, a second gerotor, and a synchronizing system operable to synchronize a rotation of the first gerotor with a rotation of the second gerotor. The synchronizing system includes a cam plate coupled to the first gerotor, wherein the cam plate includes a plurality of cams, and an alignment plate coupled to the second gerotor. The alignment plate includes at least one alignment member, wherein the plurality of cams and the at least one alignment member interact to synchronize a rotation of the first gerotor with a rotation of the second gerotor.

18 Claims, 91 Drawing Sheets

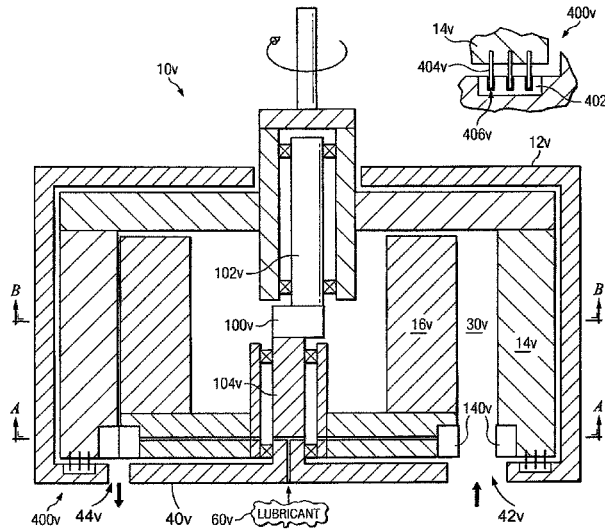

(56)

References Cited

U.S. PATENT DOCUMENTS

- | | | | | | | | |
|-----------|----|---------|----------------------------|--------------|-----|---------|----------------------------|
| 2,138,490 | A | 11/1938 | Haller | 5,284,016 | A | 2/1994 | Stark |
| 2,240,056 | A | 4/1941 | Schmitz | 5,289,072 | A | 2/1994 | Lange |
| 2,291,354 | A | 7/1942 | Sibley | 5,311,739 | A | 5/1994 | Clark |
| 2,373,368 | A | 4/1945 | Witchger | 5,472,329 | A | 12/1995 | Maynard et al. |
| 2,459,447 | A | 1/1949 | Milliken | 5,522,356 | A | 6/1996 | Palmer |
| 2,601,397 | A | 6/1952 | Hill et al. | 5,538,073 | A | 7/1996 | Stopa |
| 2,938,663 | A | 5/1960 | Luck | 5,554,020 | A | 9/1996 | Rao et al. |
| 2,965,039 | A | 12/1960 | Morita | 5,557,921 | A | 9/1996 | Fruttschi et al. |
| 2,974,482 | A | 3/1961 | Kelley | 5,617,719 | A | 4/1997 | Ginter |
| 3,037,348 | A | 6/1962 | Gassmann | 5,618,171 | A | 4/1997 | von Behr et al. |
| 3,082,747 | A | 3/1963 | Friedrich | 5,622,044 | A | 4/1997 | Bronicki et al. |
| 3,126,755 | A | 3/1964 | Friedrich | 5,634,339 | A | 6/1997 | Lewis et al. |
| 3,167,913 | A | 2/1965 | Muhlberg et al. | 5,682,738 | A | 11/1997 | Barber |
| 3,170,409 | A* | 2/1965 | McLeod et al. 418/133 | 5,733,111 | A | 3/1998 | Yu et al. |
| 3,214,087 | A | 10/1965 | Luck | 5,755,196 | A | 5/1998 | Klassen |
| 3,226,013 | A | 12/1965 | Toyoda et al. | 5,761,898 | A | 6/1998 | Barnes et al. |
| 3,273,341 | A | 9/1966 | Wildhaber | 5,769,619 | A | 6/1998 | Crvelin et al. |
| 3,295,748 | A | 1/1967 | Leitgeb | 5,798,591 | A | 8/1998 | Lillington et al. |
| 3,303,783 | A | 2/1967 | Neubauer | 5,836,192 | A | 11/1998 | Getman et al. |
| 3,303,784 | A | 2/1967 | Neubauer | 5,839,270 | A | 11/1998 | Jirnov et al. |
| 3,334,253 | A | 8/1967 | Hill | 5,854,526 | A | 12/1998 | Sakamoto |
| 3,459,337 | A | 8/1969 | Williamson | 5,951,268 | A | 9/1999 | Pottier et al. |
| 3,536,426 | A | 10/1970 | Albrecht et al. | 5,964,087 | A | 10/1999 | Tort-Oropeza |
| 3,574,489 | A | 4/1971 | Pierrat | 6,085,829 | A | 7/2000 | Neuhaus et al. |
| 3,623,317 | A | 11/1971 | Foster-Pegg | 6,174,151 | B1 | 1/2001 | Yarr |
| 3,657,879 | A | 4/1972 | Ewbank et al. | 6,273,055 | B1 | 8/2001 | White |
| 3,844,117 | A | 10/1974 | Ryan | 6,313,544 | B1 | 11/2001 | Mongia et al. |
| 3,846,987 | A | 11/1974 | Baldwin | 6,336,317 | B1 | 1/2002 | Holtzapple et al. |
| 3,877,218 | A | 4/1975 | Nebgen | 6,427,453 | B1 | 8/2002 | Holtzapple et al. |
| 3,894,255 | A | 7/1975 | Newton, Jr. | 6,487,862 | B1 | 12/2002 | Doorley |
| 3,928,974 | A | 12/1975 | Benson | 6,488,004 | B1 | 12/2002 | Adamovski |
| 3,932,987 | A | 1/1976 | Munzinger | 6,530,211 | B2 | 3/2003 | Holtzapple et al. |
| 3,972,652 | A | 8/1976 | Minnicino | 6,758,656 | B2* | 7/2004 | Maier et al. 418/61.3 |
| 3,995,431 | A | 12/1976 | Schwartzman | 6,886,326 | B2 | 5/2005 | Holtzapple et al. |
| 4,023,366 | A | 5/1977 | Schneider | 7,008,200 | B2 | 3/2006 | Holtzapple et al. |
| 4,028,023 | A | 6/1977 | Labus | 7,186,101 | B2 | 3/2007 | Holtzapple et al. |
| 4,044,558 | A | 8/1977 | Benson | 2002/0014069 | A1 | 2/2002 | Holtzapple et al. |
| 4,052,928 | A | 10/1977 | Pierrat et al. | 2003/0011268 | A1 | 1/2003 | Even et al. |
| 4,058,938 | A | 11/1977 | Harle et al. | 2003/0215345 | A1 | 11/2003 | Holtzapple et al. |
| 4,074,533 | A | 2/1978 | Stockton | 2003/0228237 | A1 | 12/2003 | Holtzapple et al. |
| 4,127,364 | A | 11/1978 | Eiermann et al. | | | | |
| 4,145,167 | A | 3/1979 | Baatrup | | | | |
| 4,179,890 | A | 12/1979 | Hanson | | | | |
| 4,199,305 | A | 4/1980 | Pareja | | | | |
| 4,336,686 | A | 6/1982 | Porter | | | | |
| 4,355,249 | A | 10/1982 | Kenwell | | | | |
| 4,392,797 | A | 7/1983 | Ruf | | | | |
| 4,439,119 | A | 3/1984 | Petersen et al. | | | | |
| 4,457,677 | A | 7/1984 | Todd | | | | |
| 4,478,553 | A | 10/1984 | Leibowitz et al. | | | | |
| 4,491,171 | A | 1/1985 | Zenkner | | | | |
| 4,502,284 | A | 3/1985 | Chrisoghilos | | | | |
| 4,519,206 | A | 5/1985 | van Michaels | | | | |
| 4,553,513 | A | 11/1985 | Miles et al. | | | | |
| 4,578,955 | A | 4/1986 | Medina | | | | |
| 4,630,447 | A | 12/1986 | Webber | | | | |
| 4,653,269 | A | 3/1987 | Johnson | | | | |
| 4,657,009 | A | 4/1987 | Zen | | | | |
| 4,674,960 | A | 6/1987 | Rando et al. | | | | |
| 4,696,158 | A | 9/1987 | DeFrancisco | | | | |
| 4,759,178 | A | 7/1988 | Joy | | | | |
| 4,775,299 | A | 10/1988 | Overfield et al. | | | | |
| 4,801,255 | A | 1/1989 | Wankel | | | | |
| 4,836,760 | A | 6/1989 | MacLeod | | | | |
| 4,940,394 | A | 7/1990 | Gibbons | | | | |
| 4,951,790 | A | 8/1990 | Blything | | | | |
| 4,958,997 | A | 9/1990 | Harwath | | | | |
| 4,976,595 | A | 12/1990 | Taniguchi | | | | |
| 4,986,739 | A | 1/1991 | Child | | | | |
| 5,044,907 | A | 9/1991 | Hirosawa et al. | | | | |
| 5,074,110 | A | 12/1991 | Singh | | | | |
| 5,101,782 | A | 4/1992 | Yang | | | | |
| 5,195,882 | A | 3/1993 | Freeman | | | | |
| 5,199,971 | A | 4/1993 | Akechi | | | | |
| 5,271,215 | A | 12/1993 | Guillet | | | | |

FOREIGN PATENT DOCUMENTS

- | | | |
|----|--------------|------------|
| DE | 3812637 | 7/1989 |
| DE | 4023299 | 2/1991 |
| DE | 19720048 | A1 11/1998 |
| EP | 02207187 | 8/1990 |
| EP | 1197634 | 4/2002 |
| FR | 2720788 | 8/1995 |
| FR | 9748884 | 12/1997 |
| FR | 2812041 | A1 7/2000 |
| GB | 2 085 969 | 5/1982 |
| GB | 2221258 | 1/1990 |
| JP | 02-207187 | 8/1990 |
| JP | 405079464 | 3/1993 |
| JP | 405001674 | 8/1993 |
| JP | 06330875 | 11/1994 |
| WO | WO 03/067030 | A2 2/2003 |

OTHER PUBLICATIONS

- PCT Written Opinion of the International Application No. PCT/US03/03549 filed Feb. 5, 2003.
- Declaration of Mark Holtzapple dated May 10, 2005, 6 pages.
- Declaration of Mark Holtzapple dated Apr. 29, 2006, 6 pages.
- Japanese Office Action (with translation) for Japanese Application No. 2006-551300, 5 pages, Jan. 21, 2005.
- Notification of Transmittal of the International Search Report and the Written Opinion of the International Searching Authority of International Application No. PCT/US2005/001941 and Invitation to pay Additional Fees, 5 pages, Jul. 23, 2006.
- PCT International Search Report dated May 28, 2003 for PCT/US03/03549 filed Feb. 5, 2003.
- EP Communication for Application No. 03737665.4; Apr. 5, 2007; Reference No. JL4578.
- PCT Notification of Transmittal of the International Search Report and the Written Opinion of the International Searching Authority, or the Declaration, PCT/US05/37802, dated May 6, 2008.

* cited by examiner

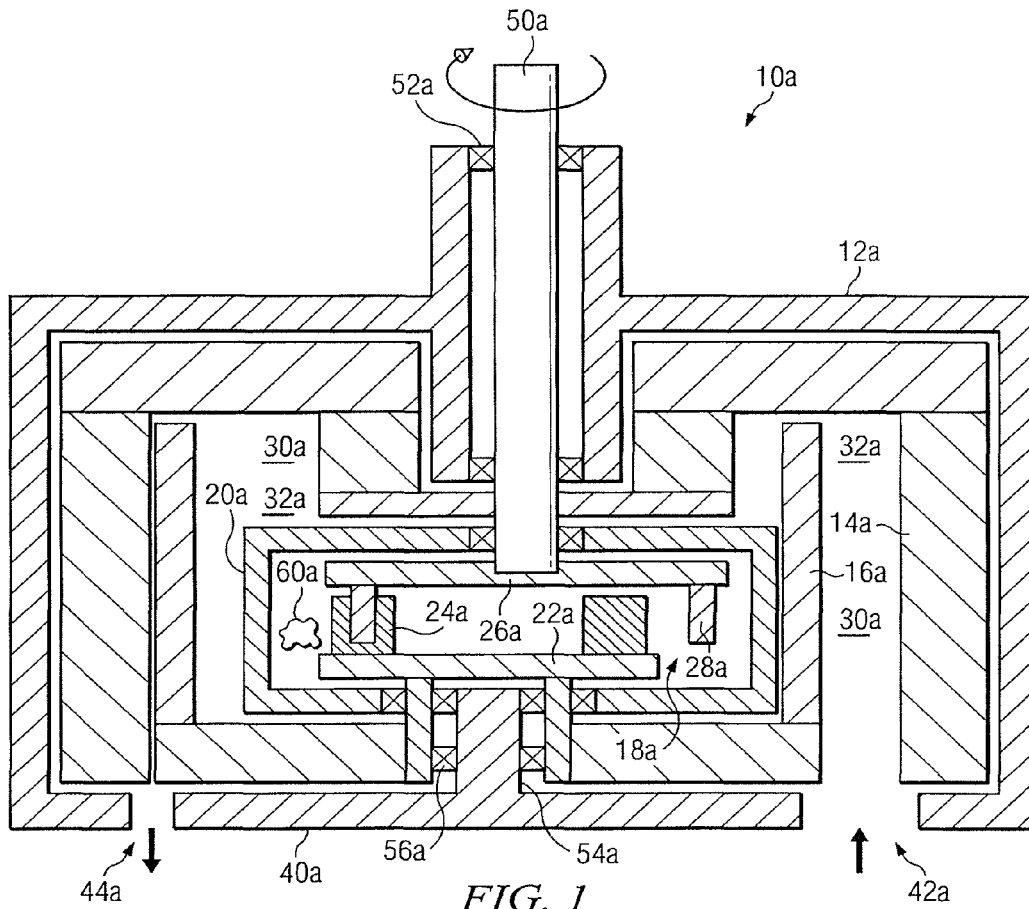

FIG. 1

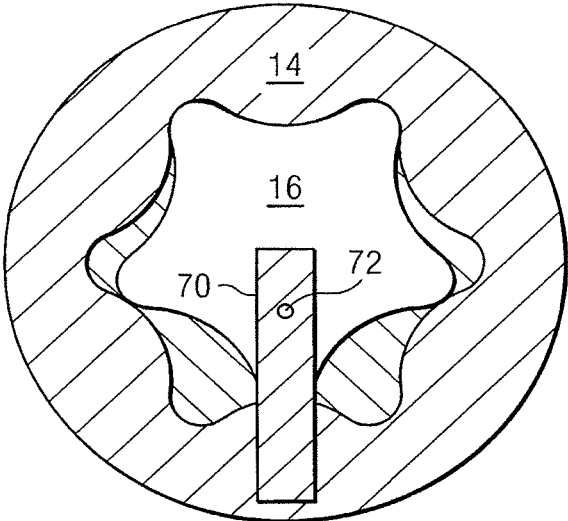

FIG. 2

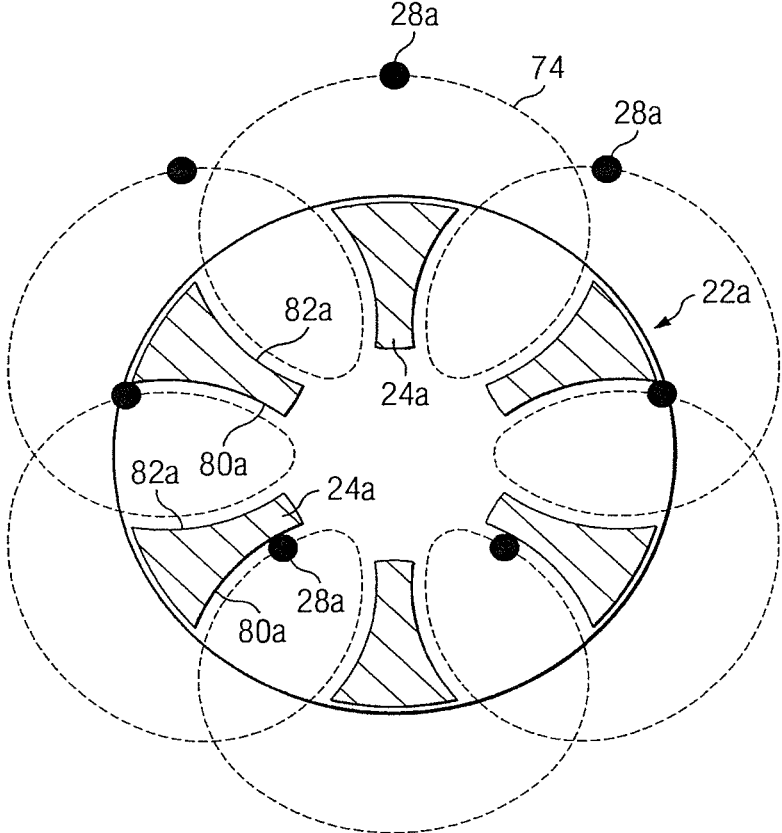
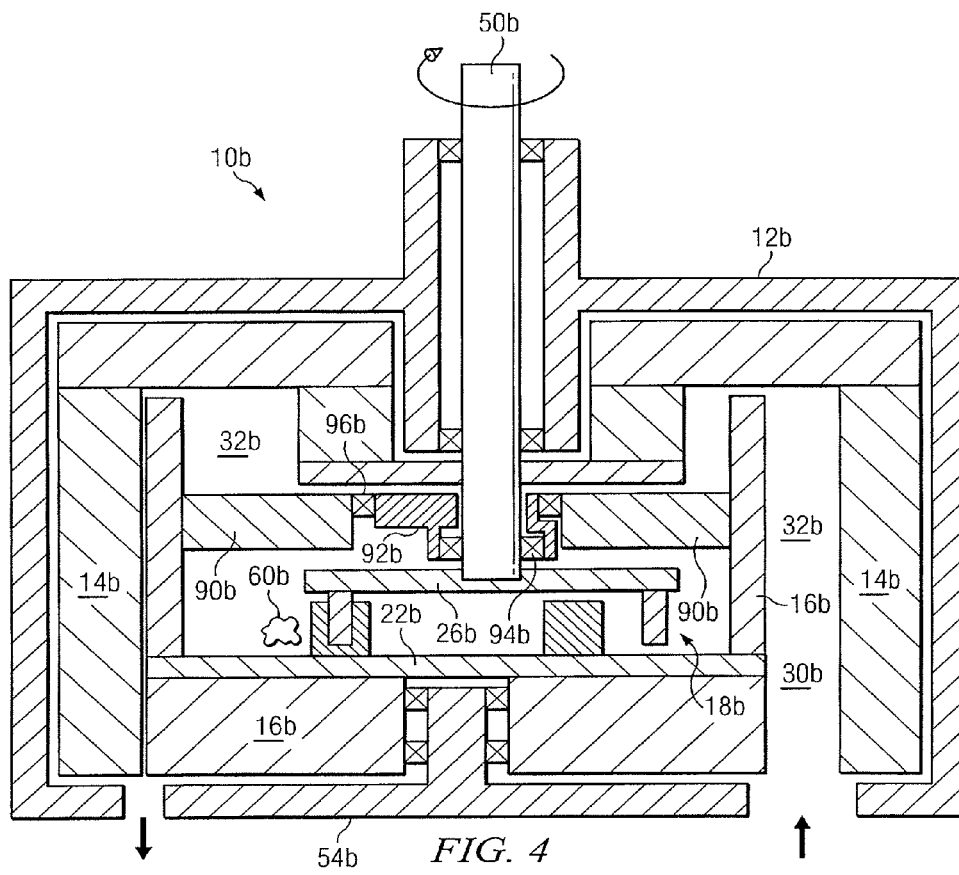

FIG. 3



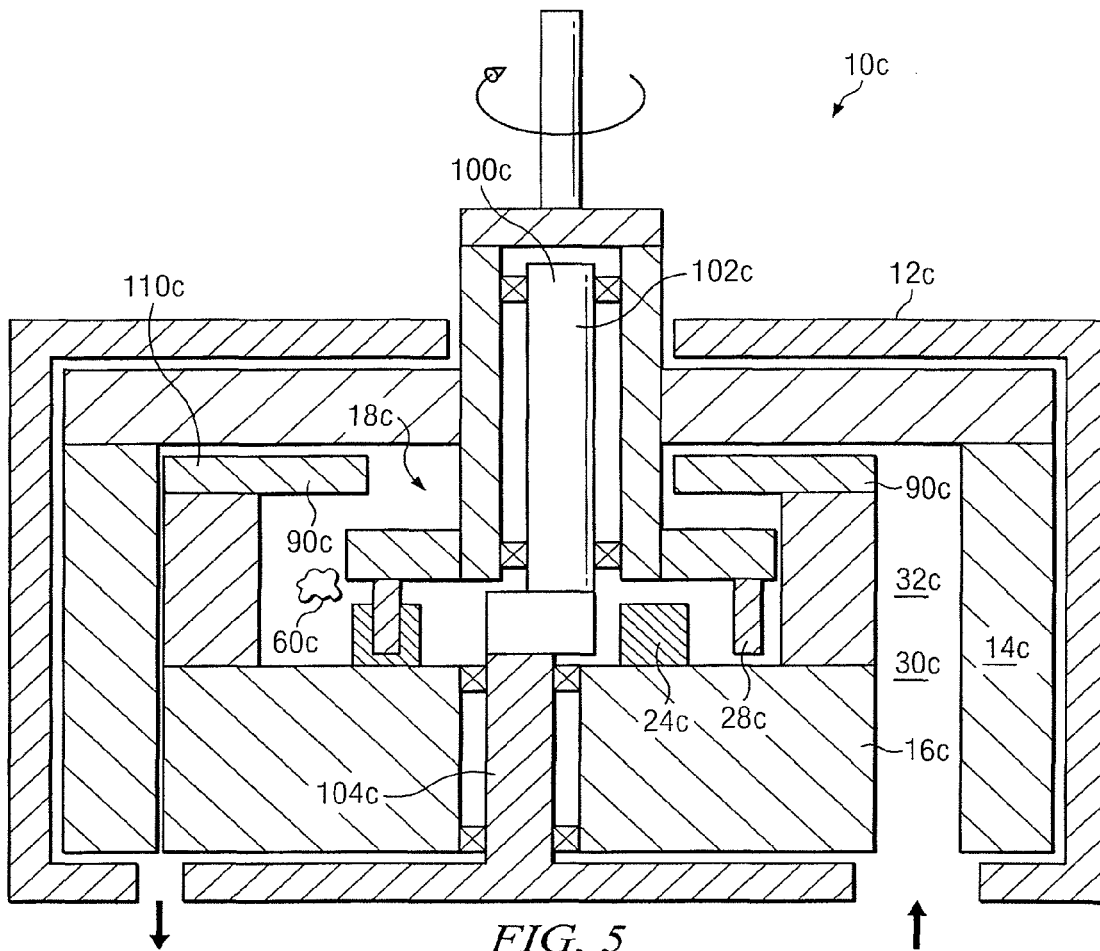

FIG. 5

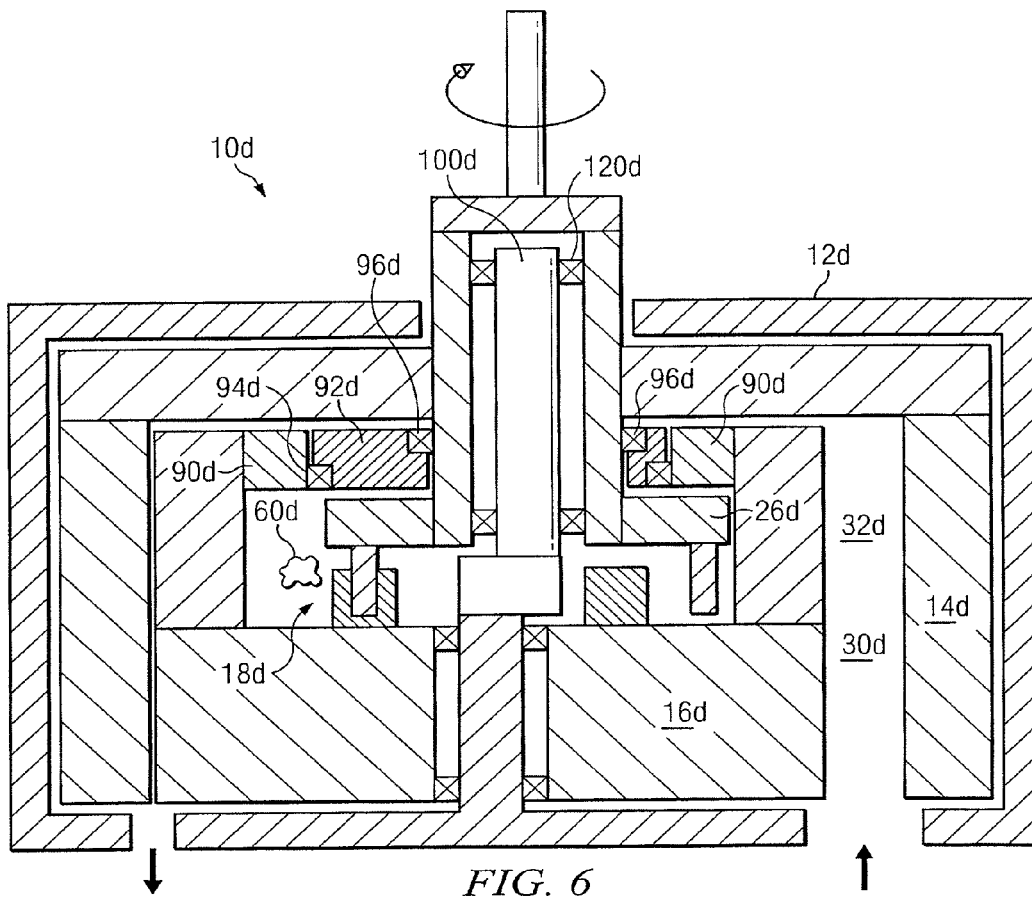

FIG. 6

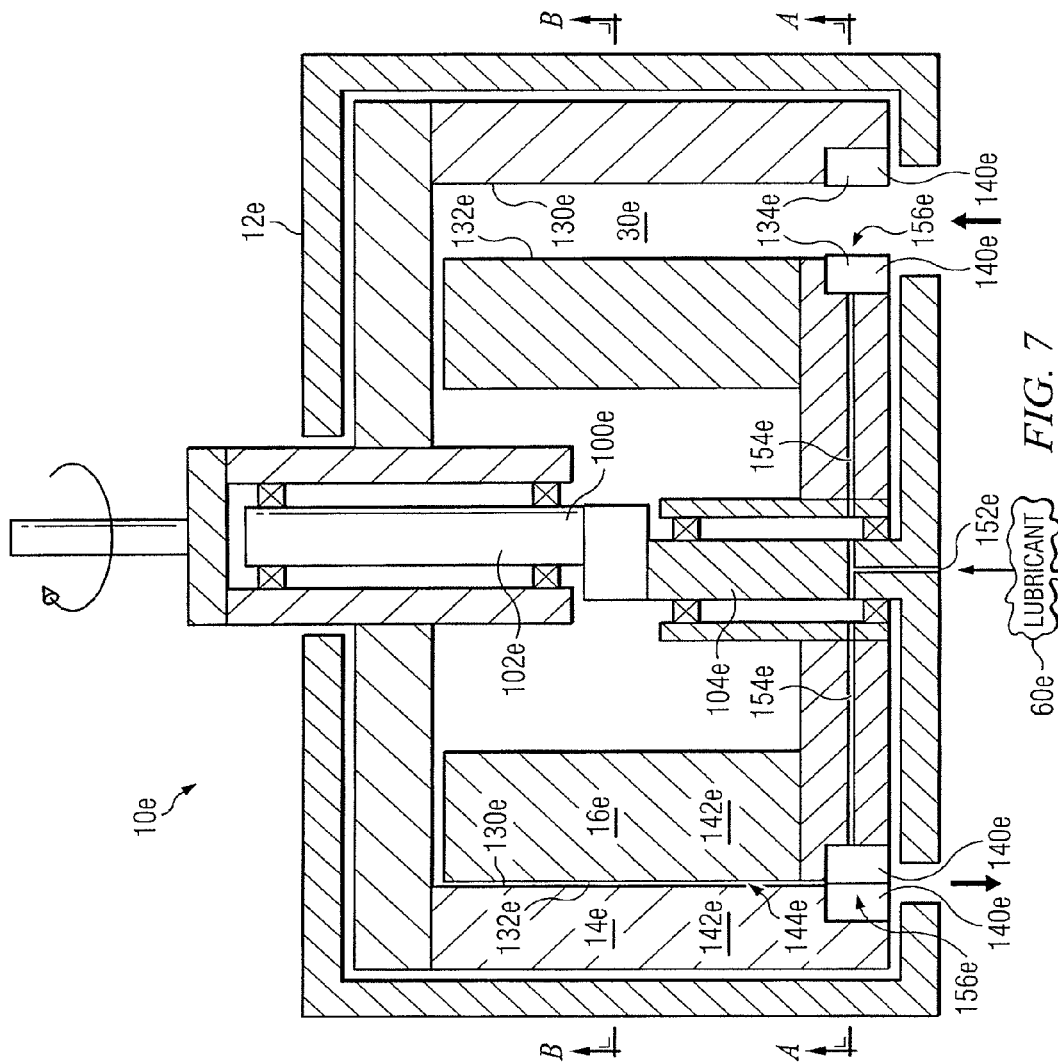

FIG. 7

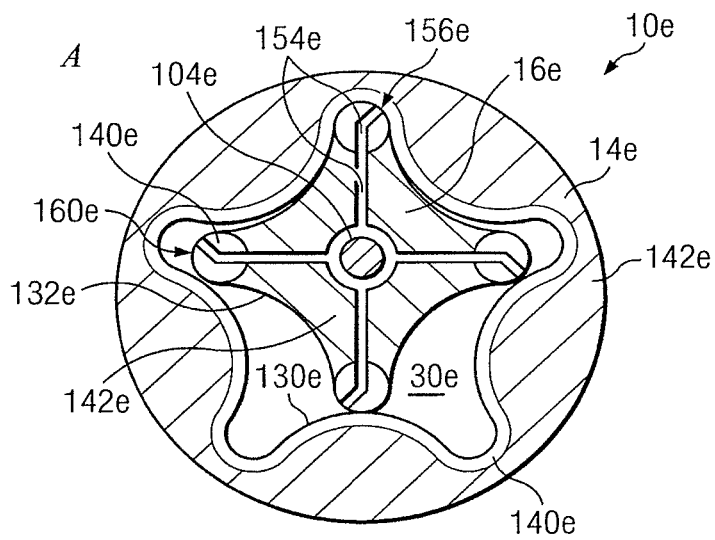
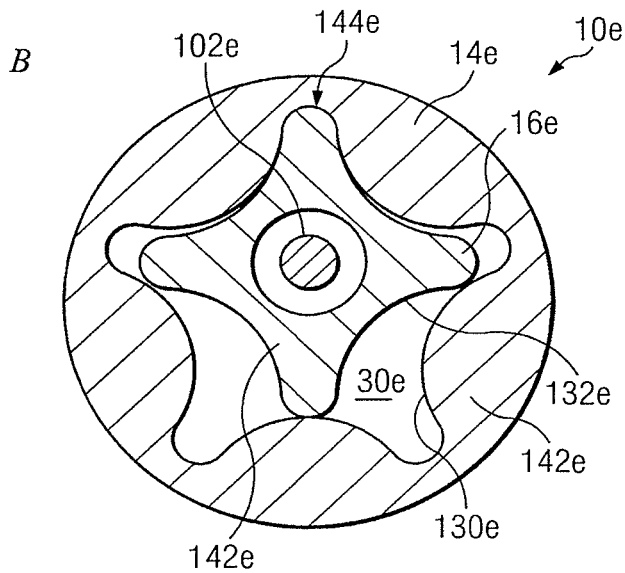

FIG. 8A



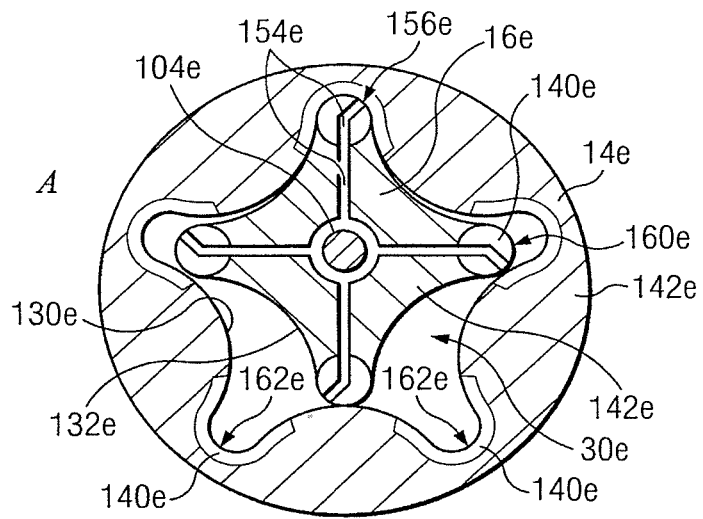
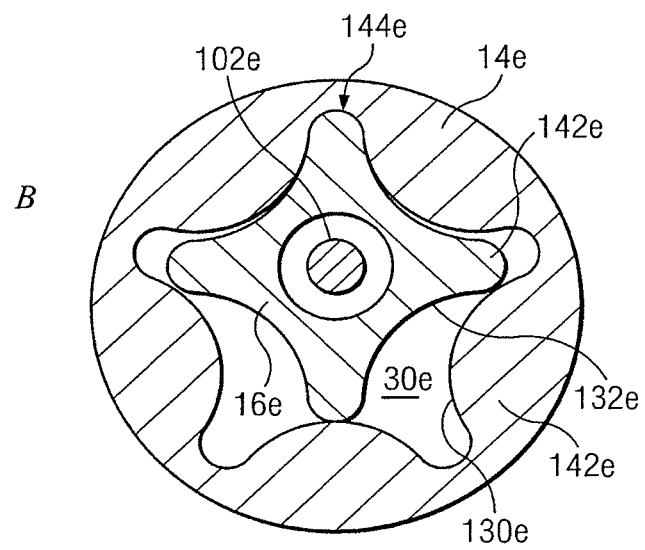

FIG. 8B



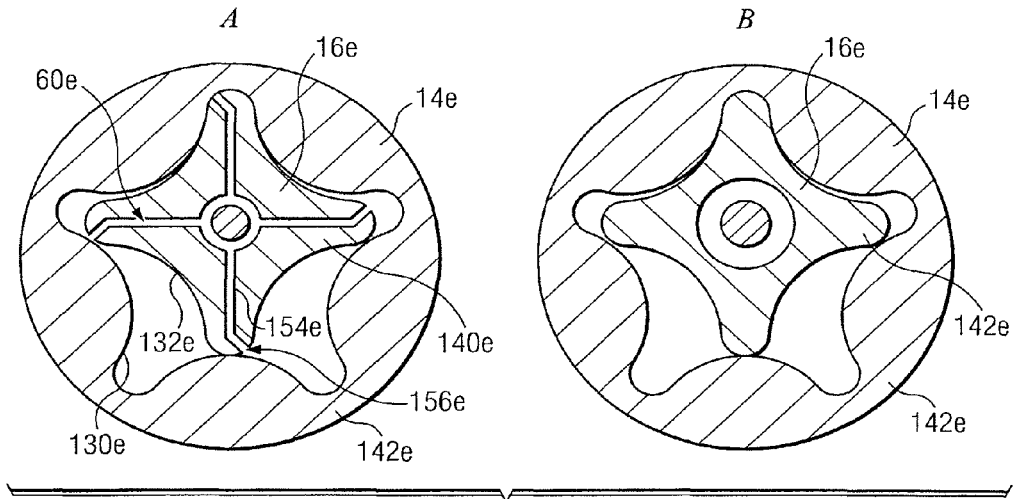

FIG. 8C

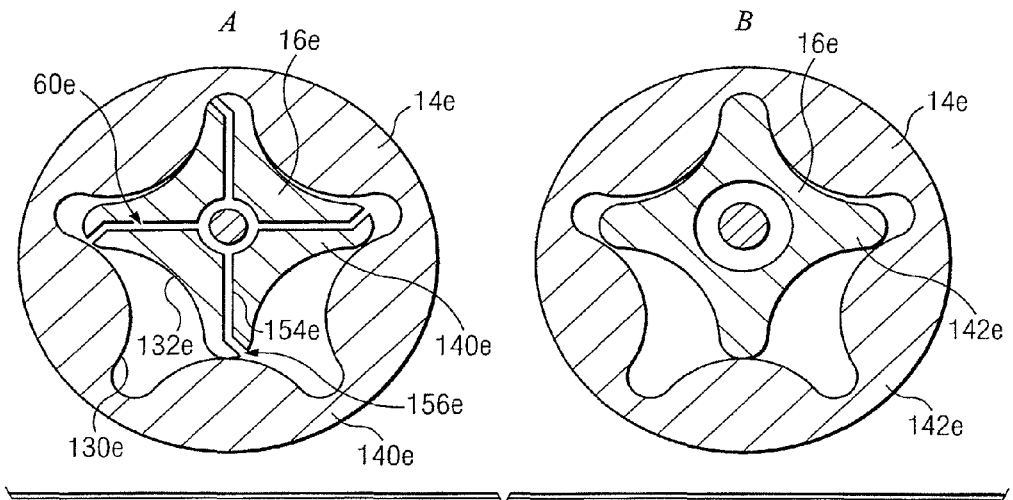

FIG. 8D

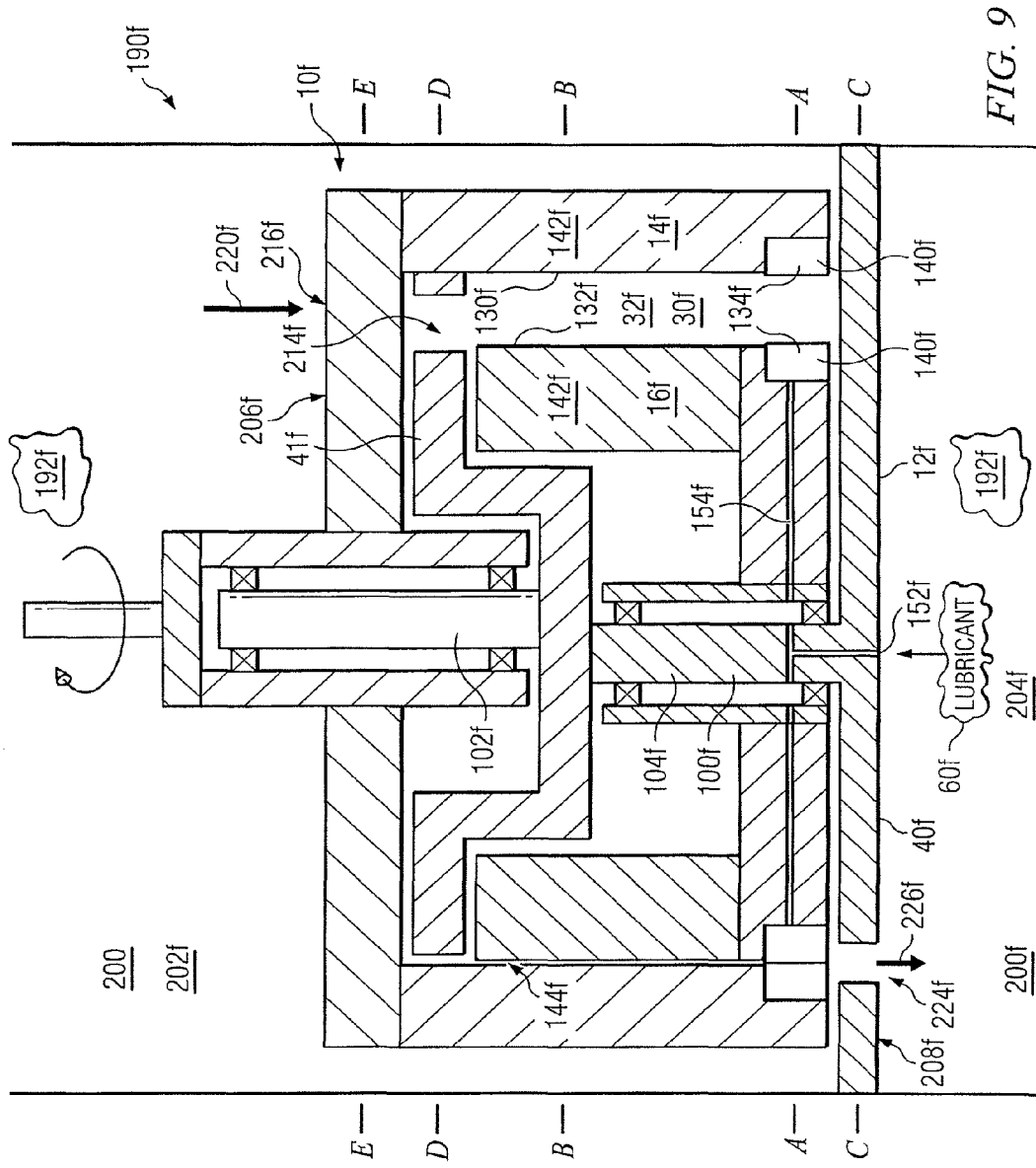

FIG. 9

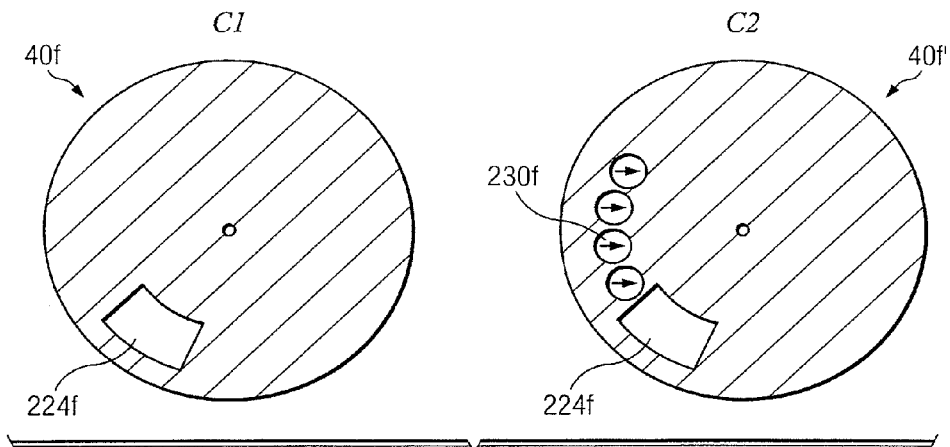

FIG. 10

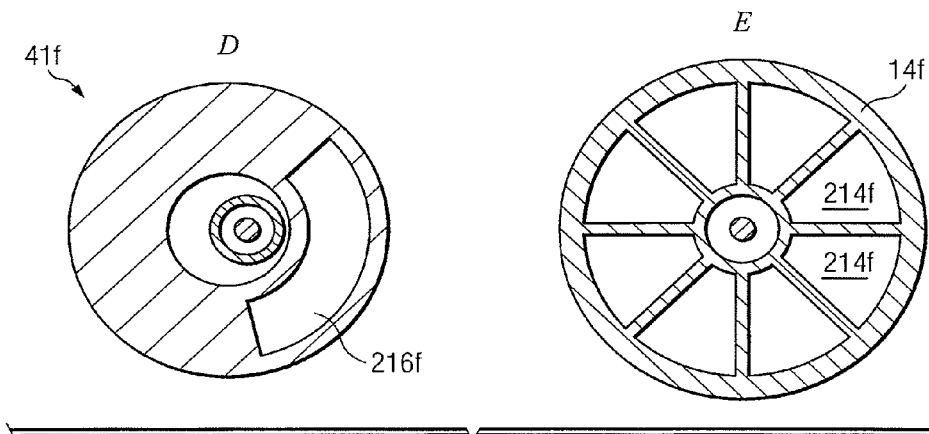

FIG. 11

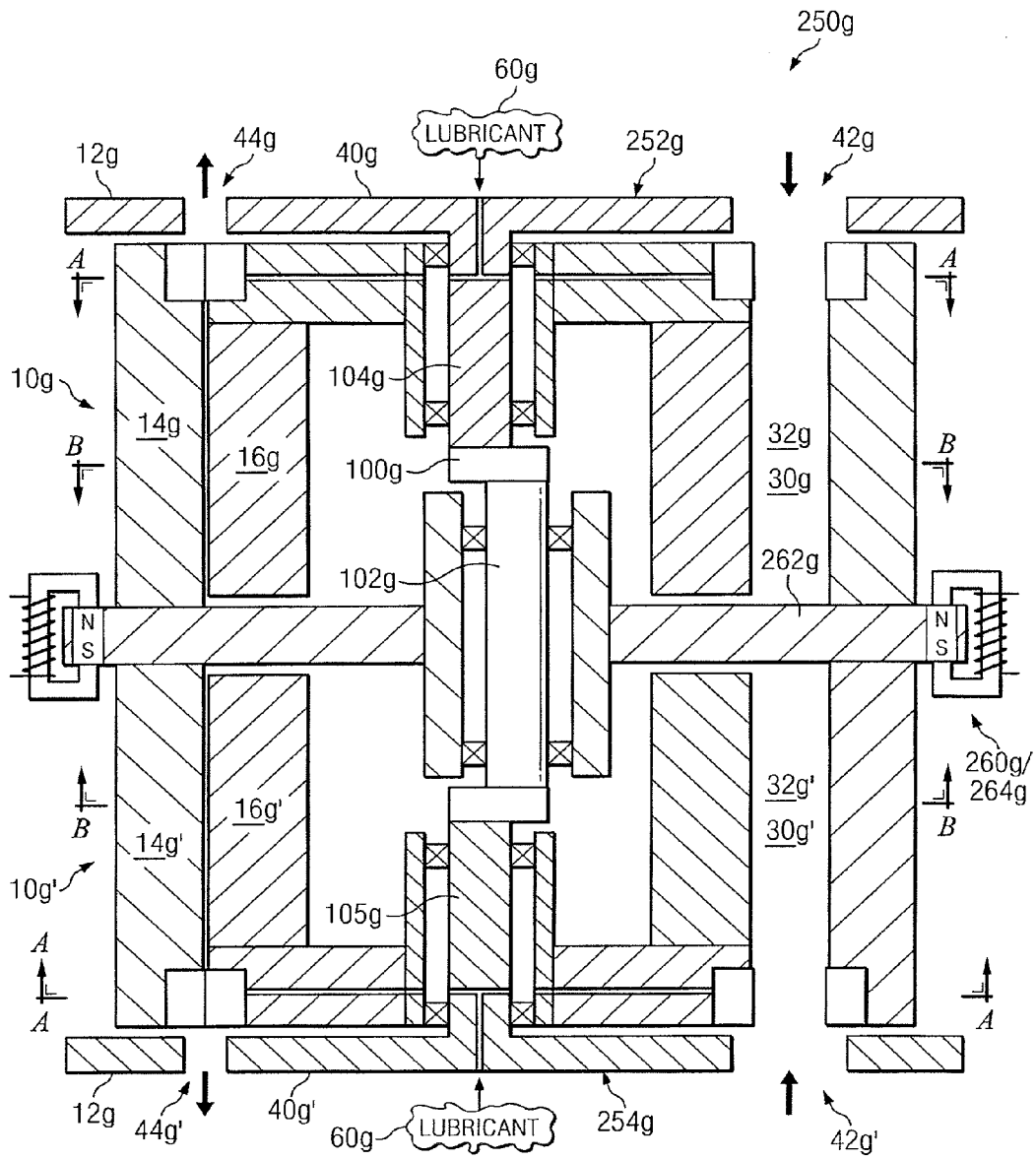

FIG. 12

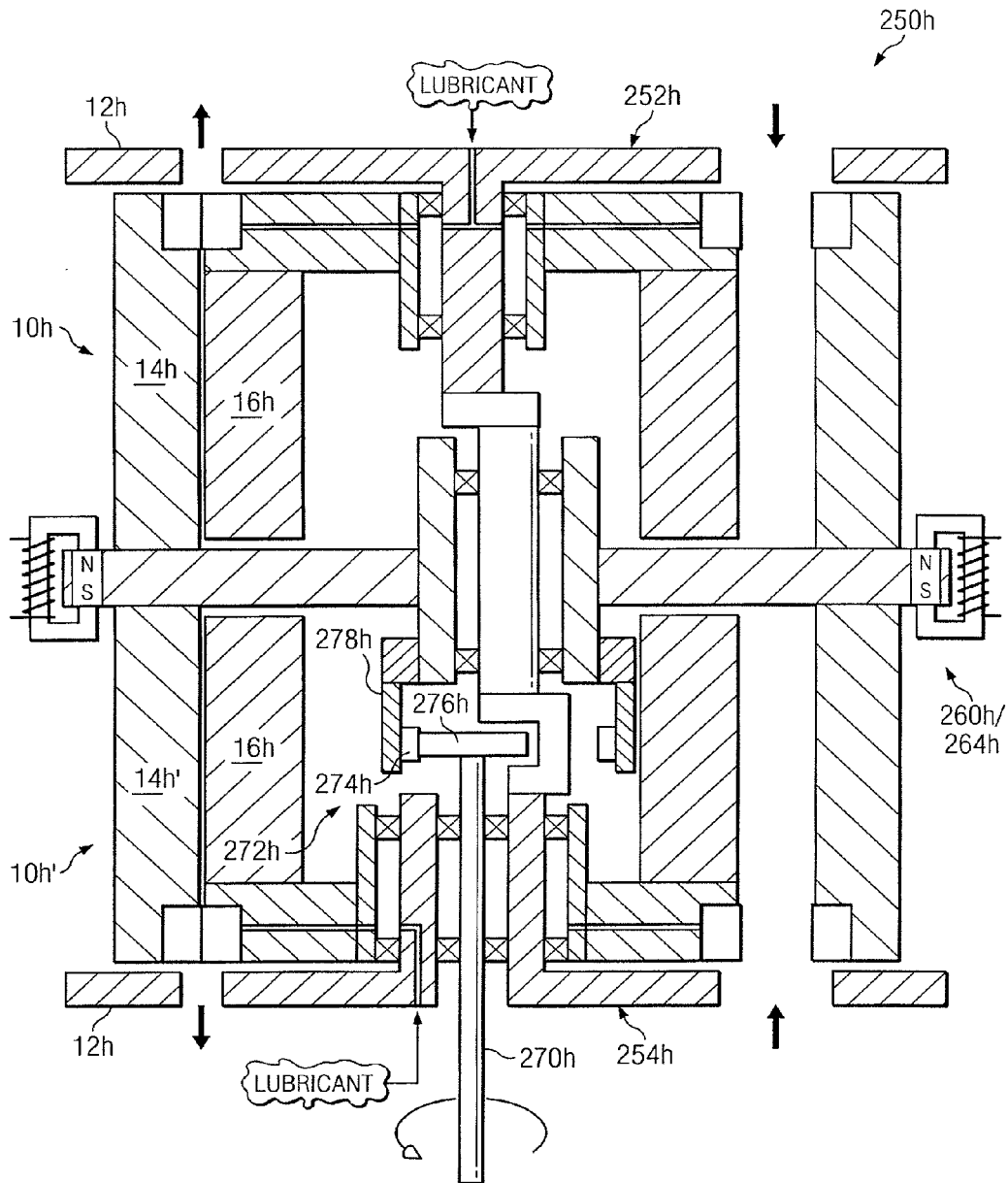

FIG. 13

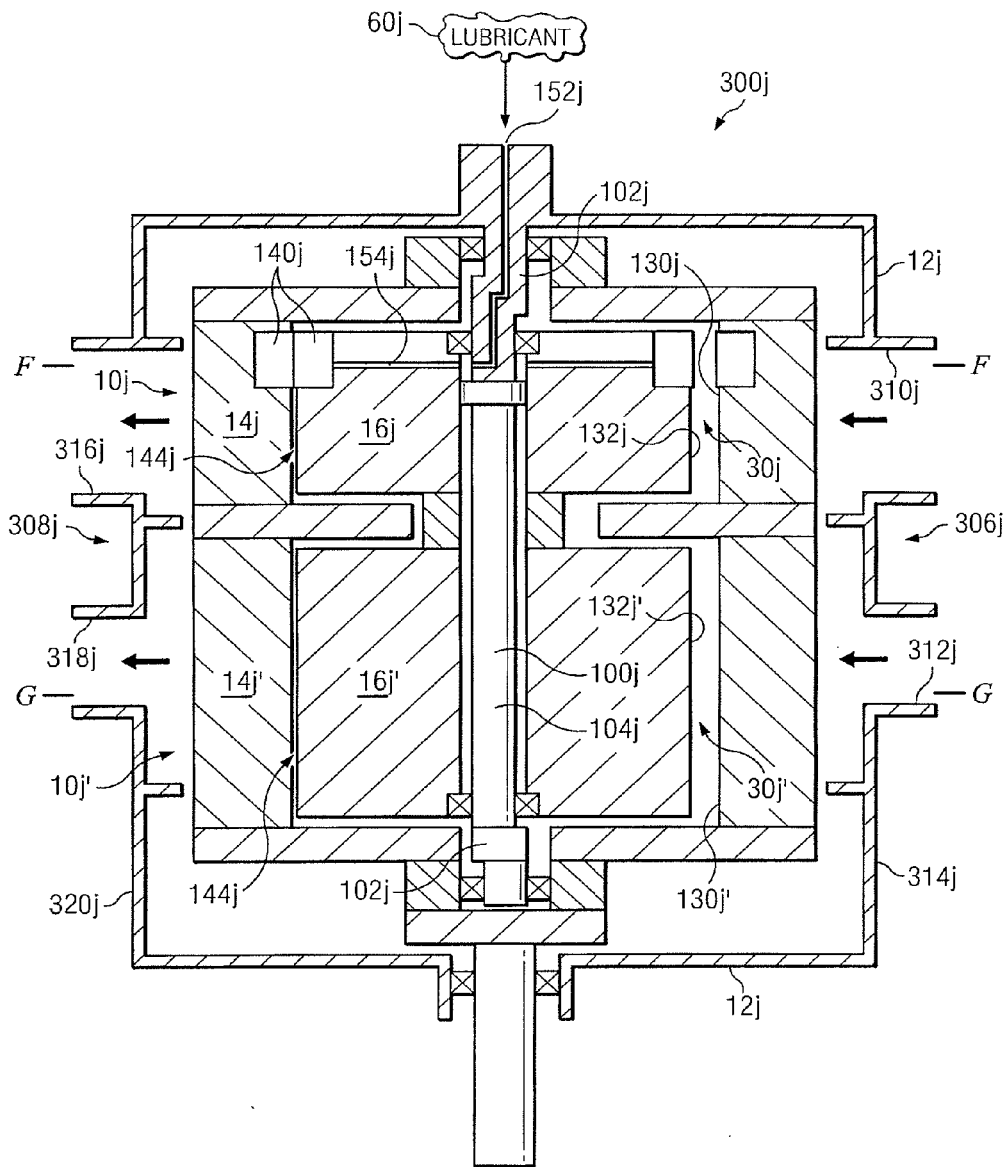

FIG. 14

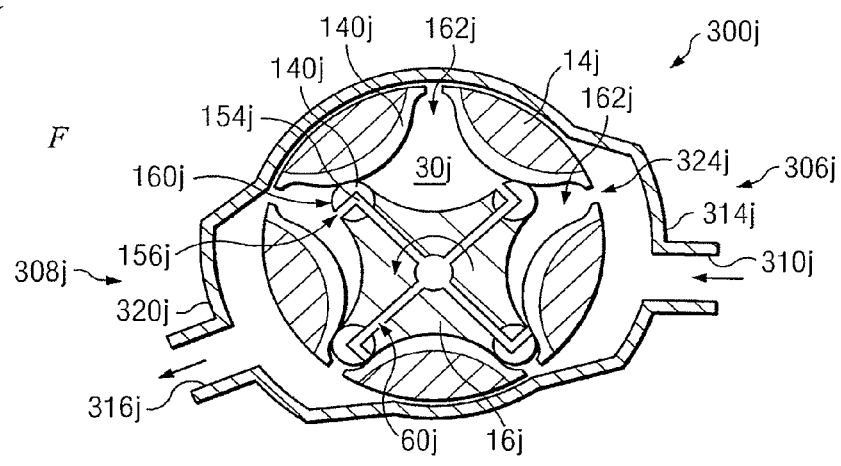
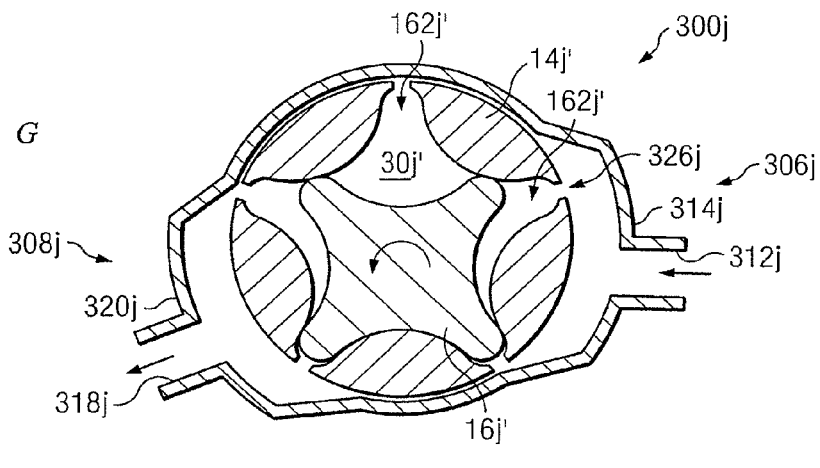

FIG. 15



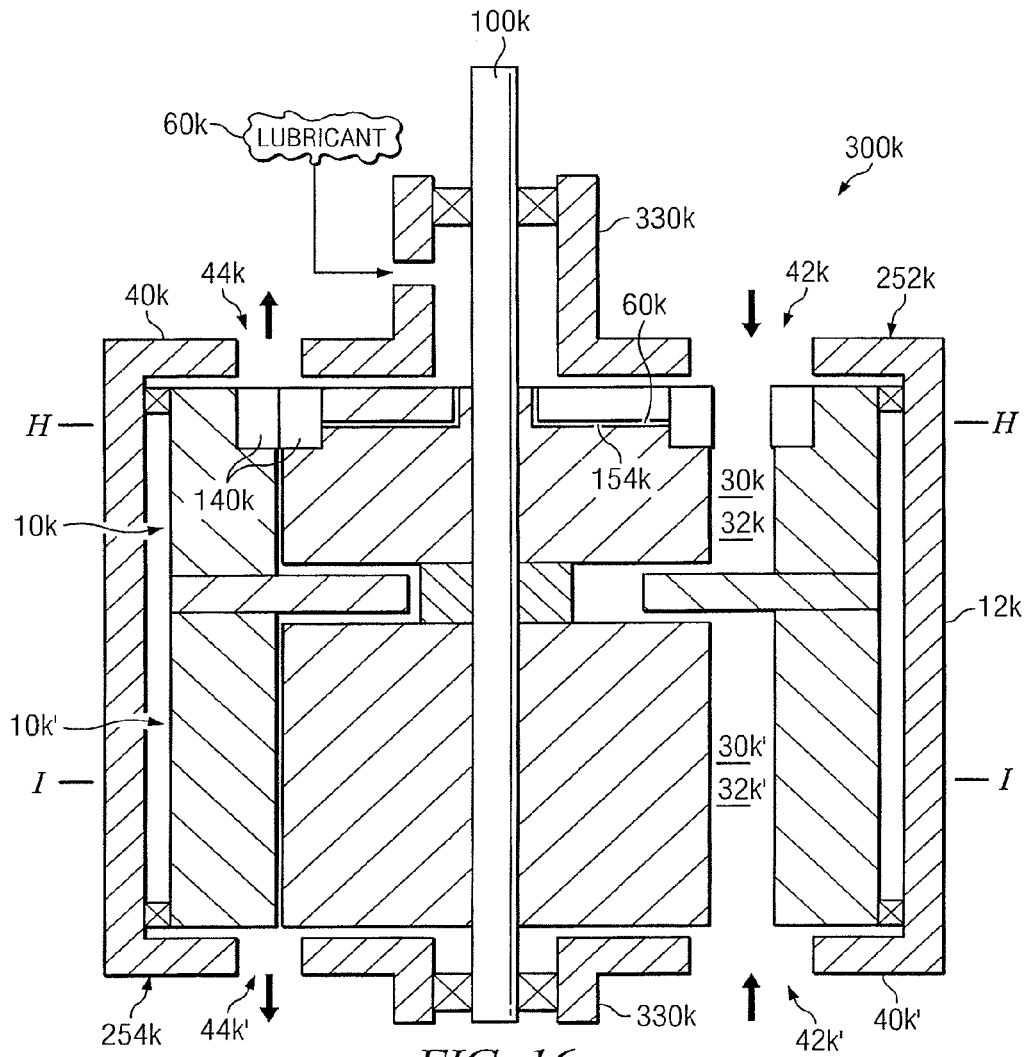

FIG. 16

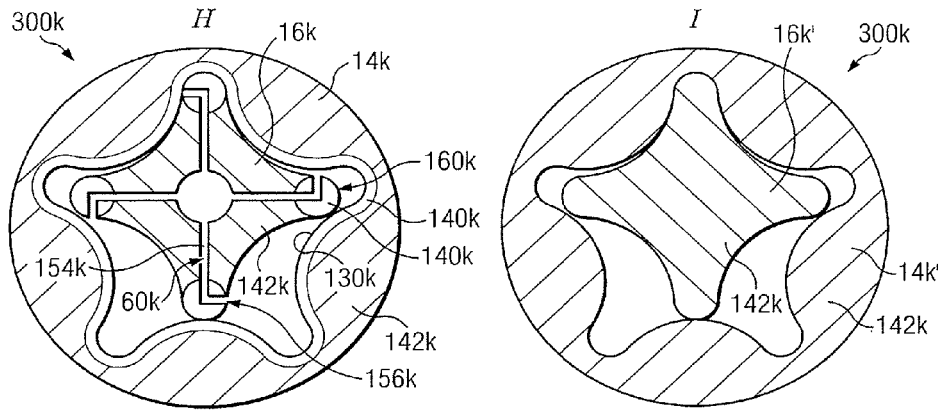

FIG. 17A

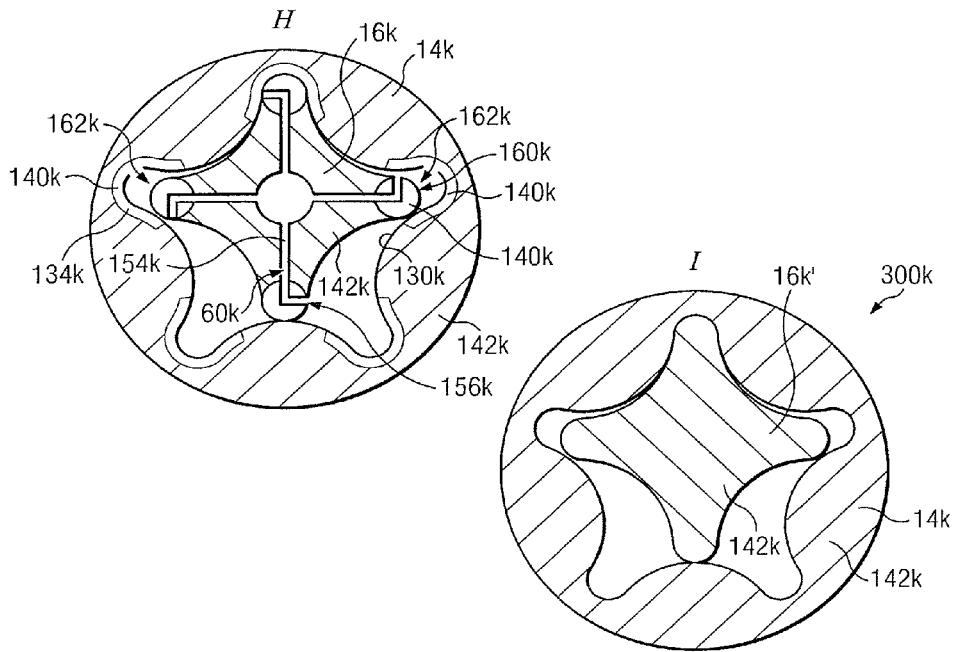

FIG. 17B

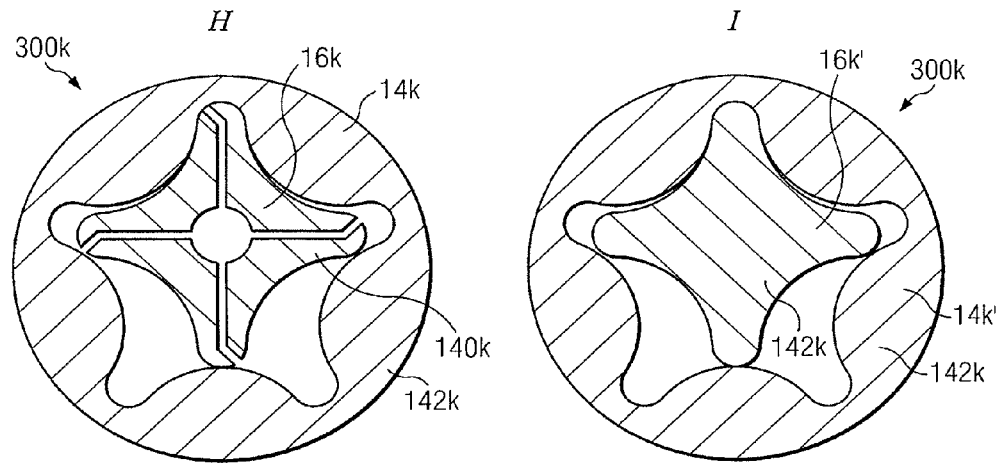

FIG. 17C

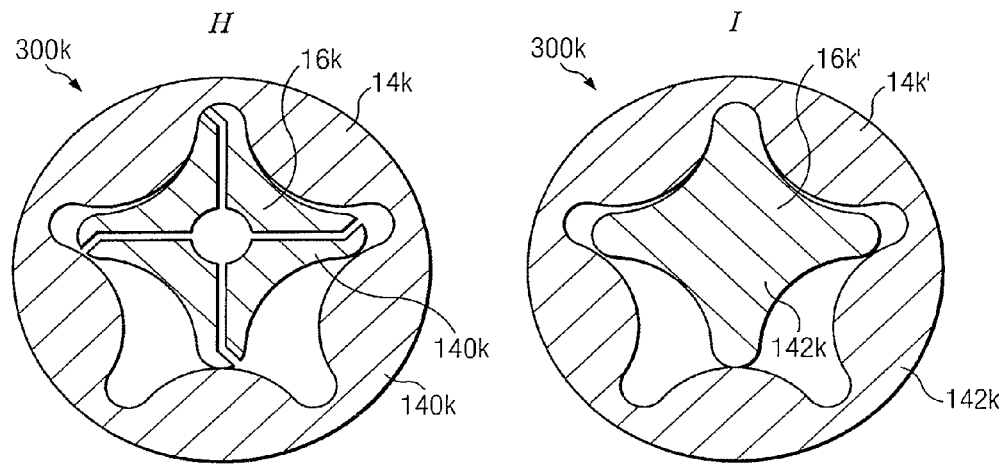

FIG. 17D

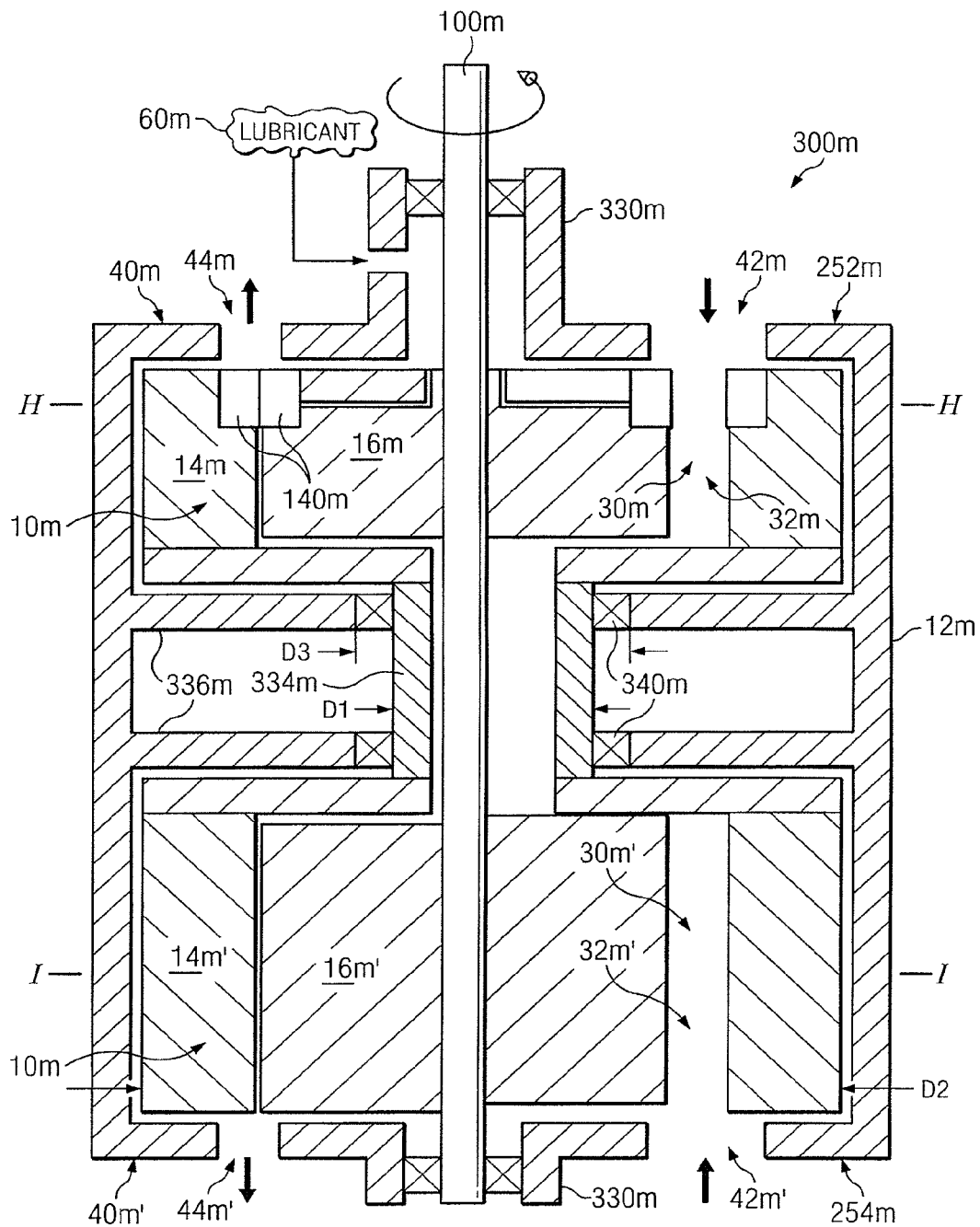

FIG. 18

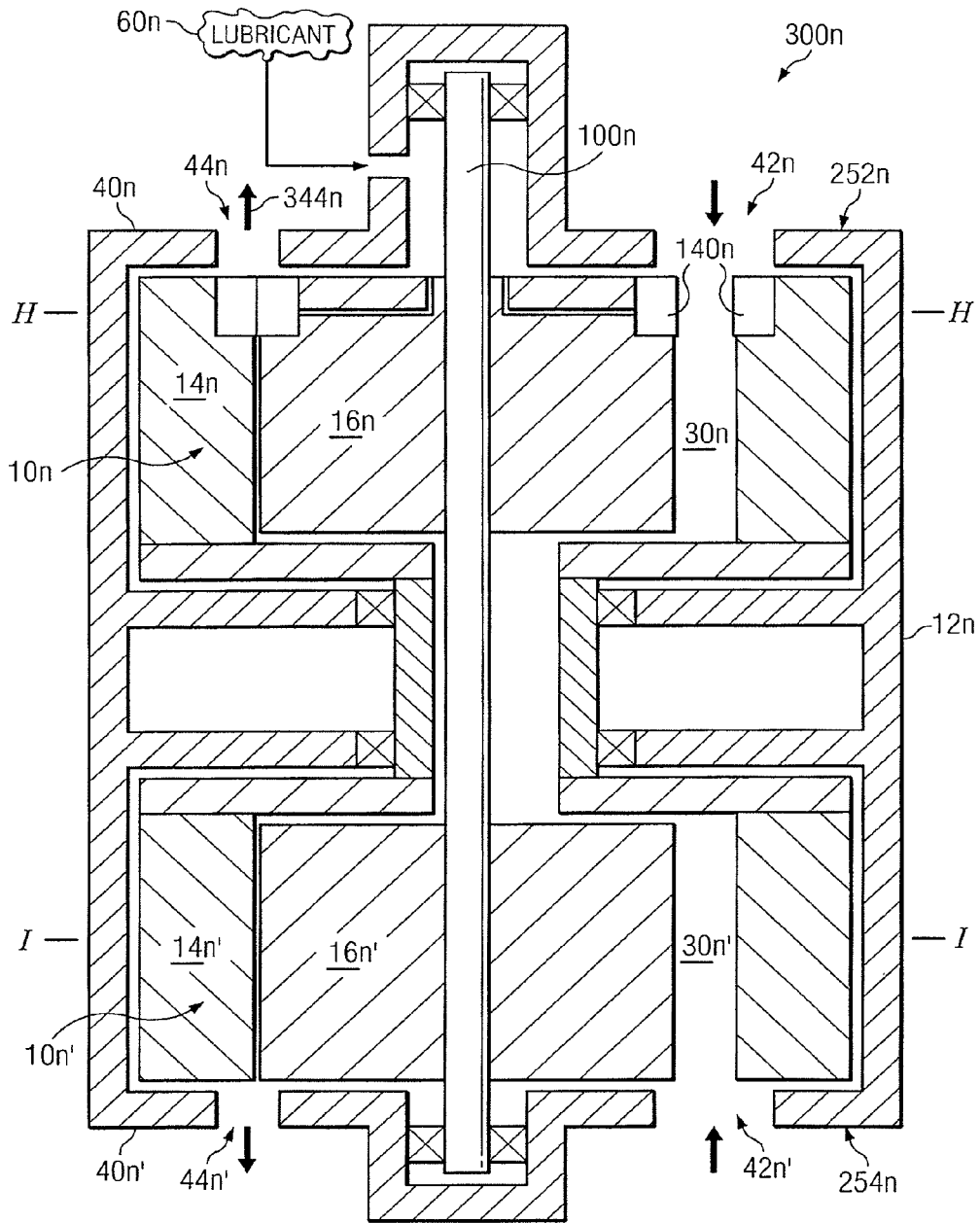

FIG. 19

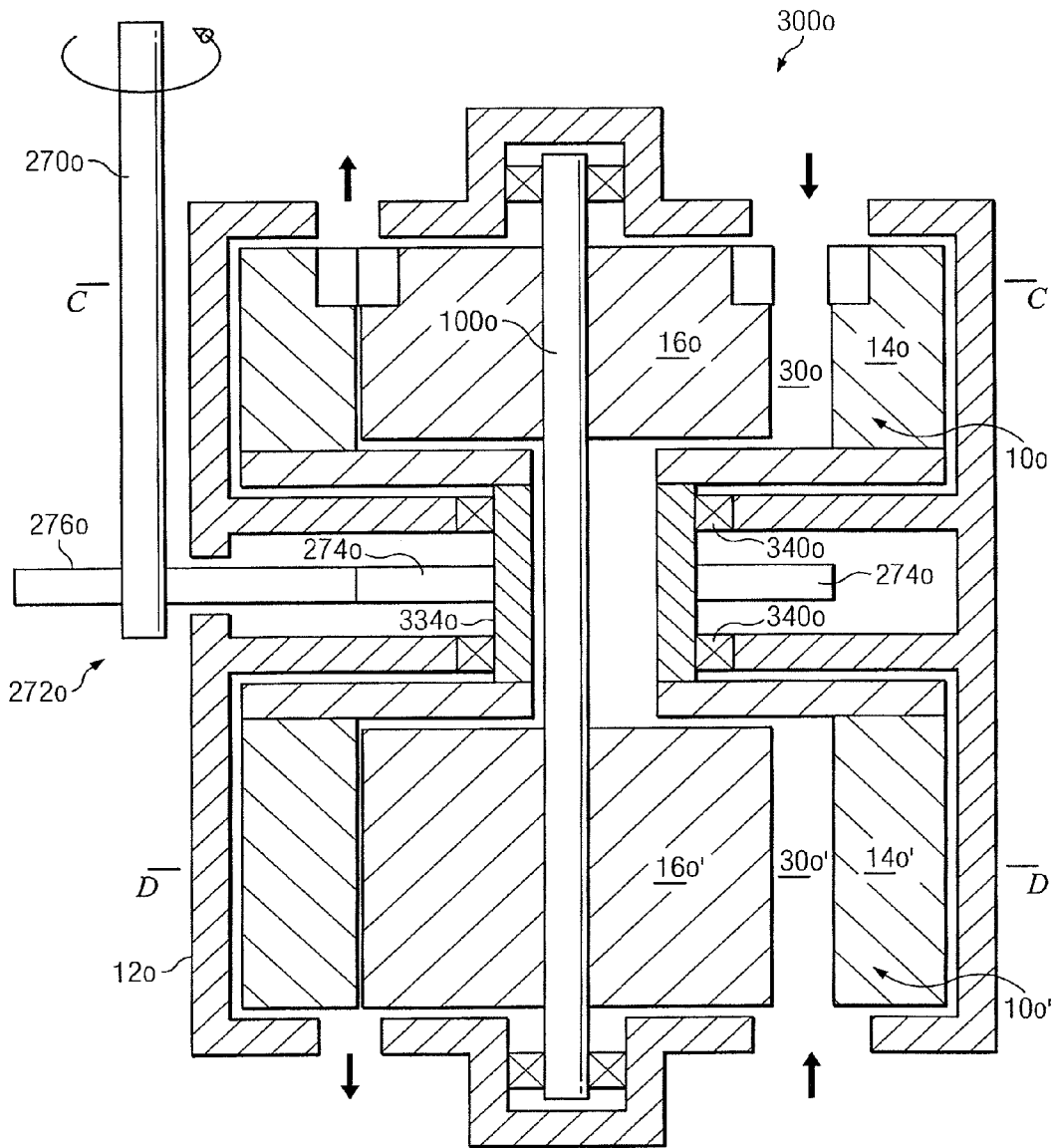

FIG. 20

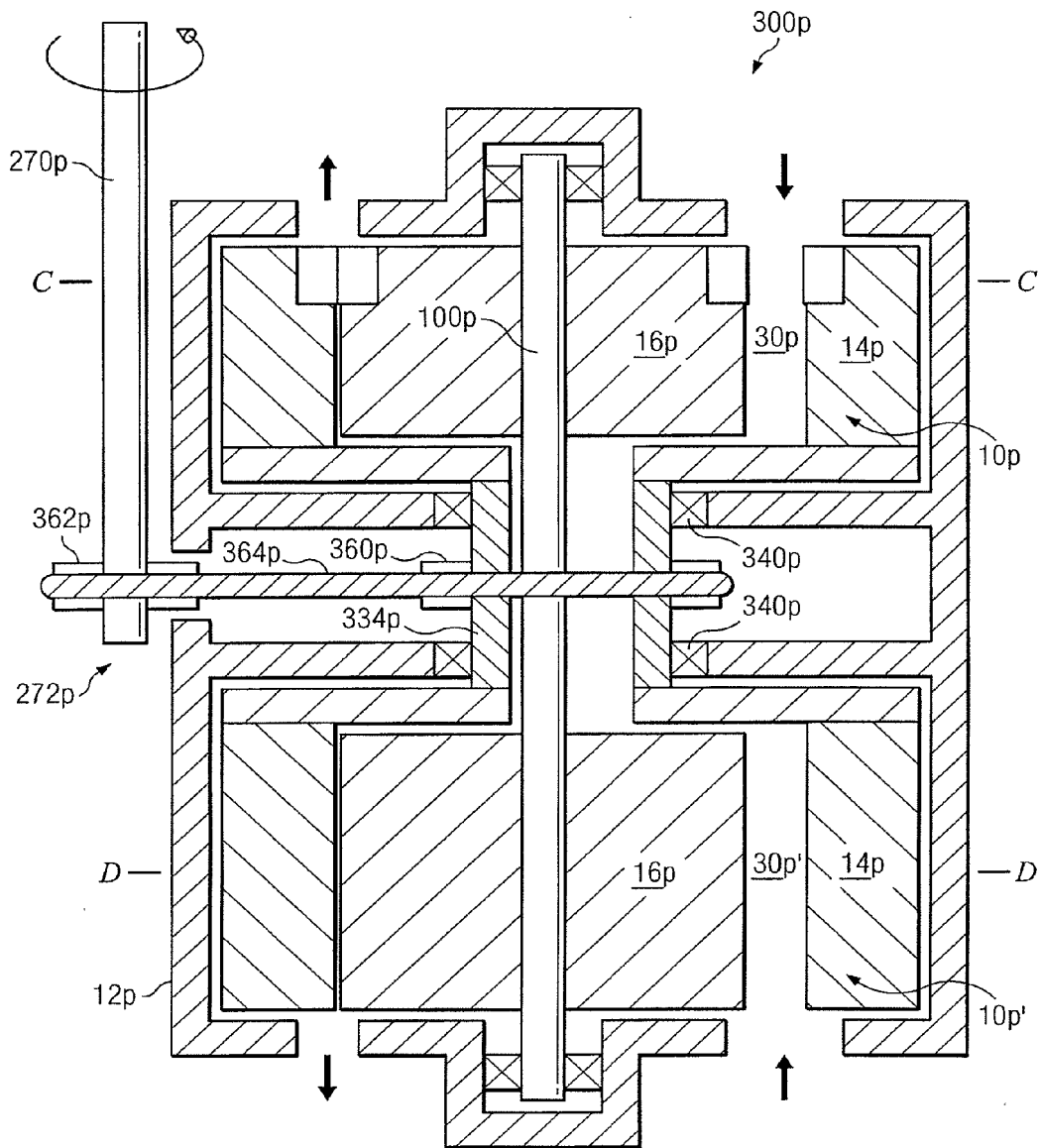

FIG. 21

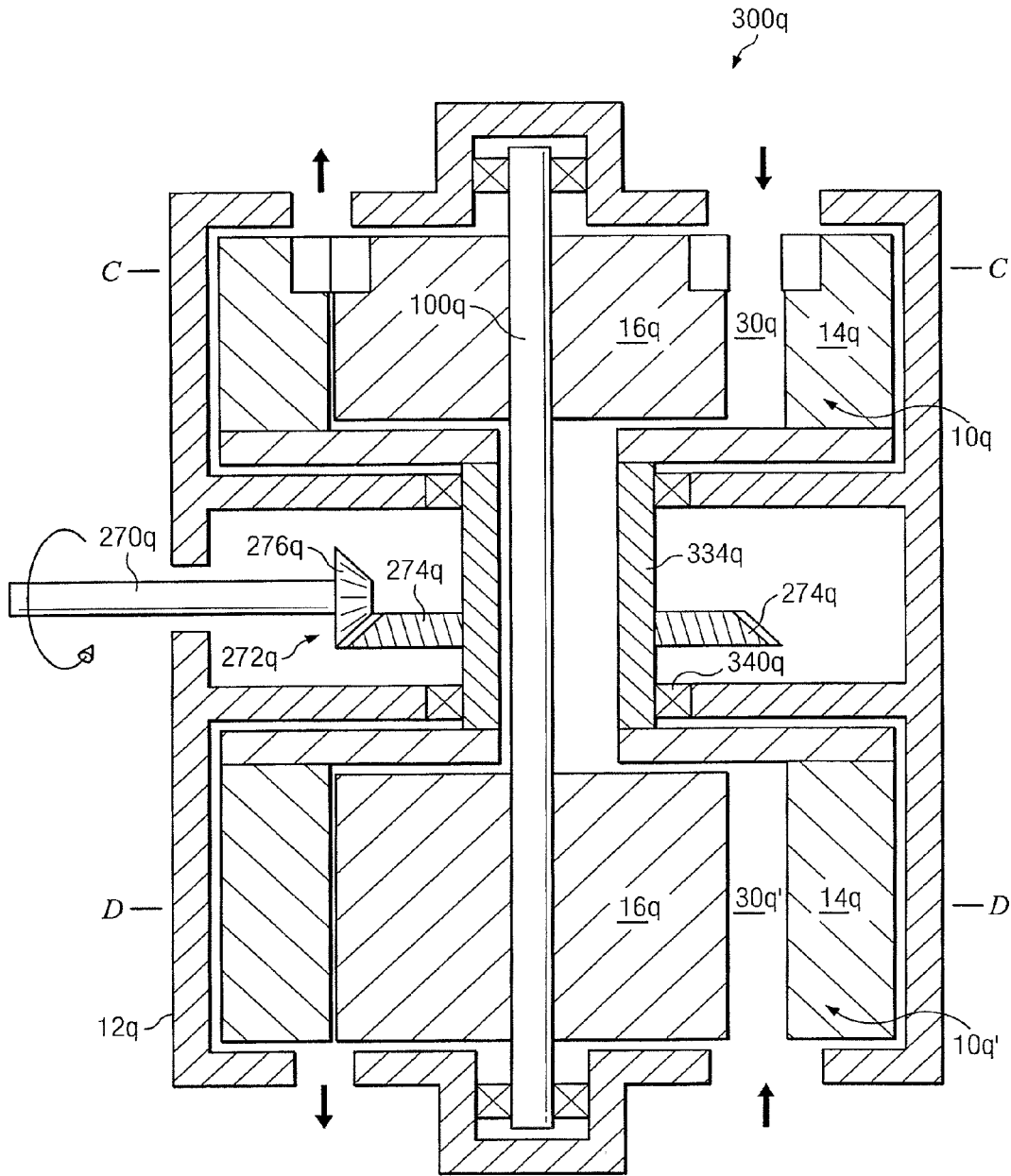

FIG. 22

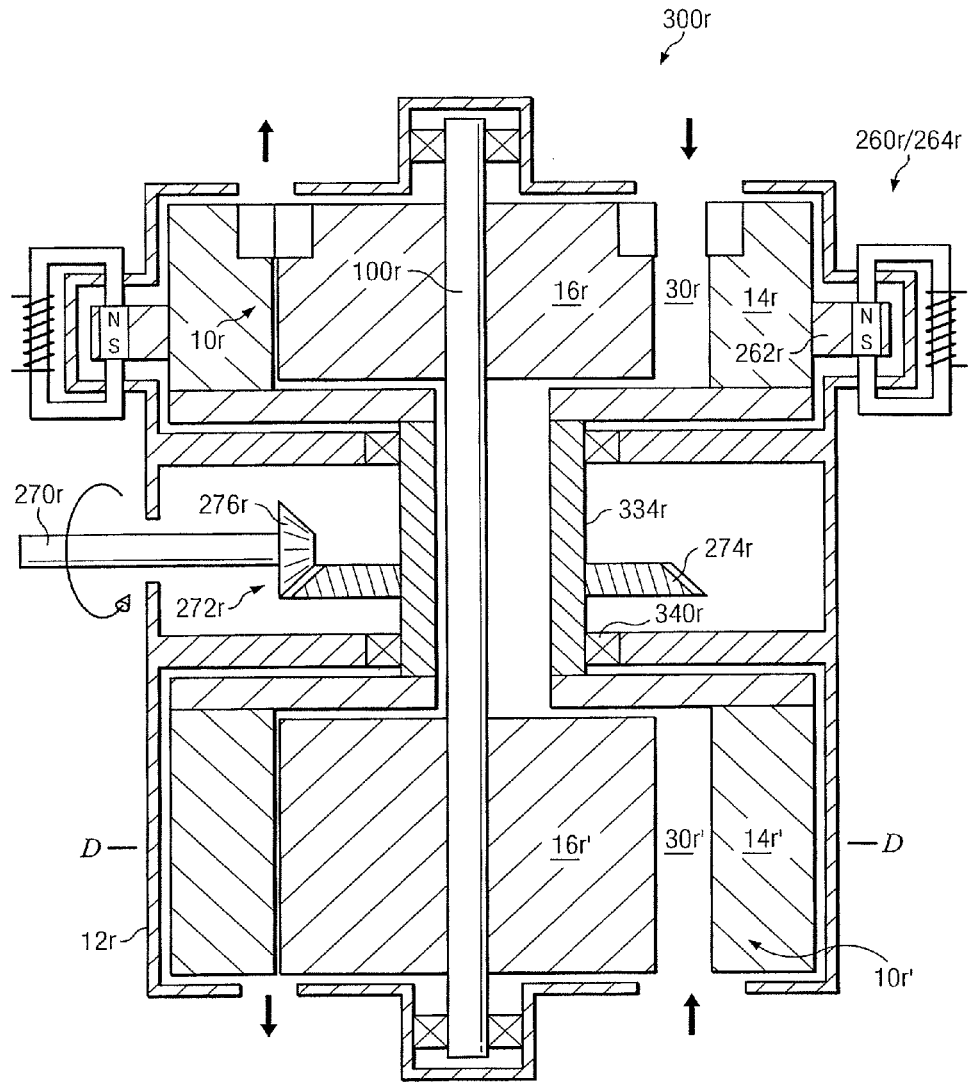

FIG. 23

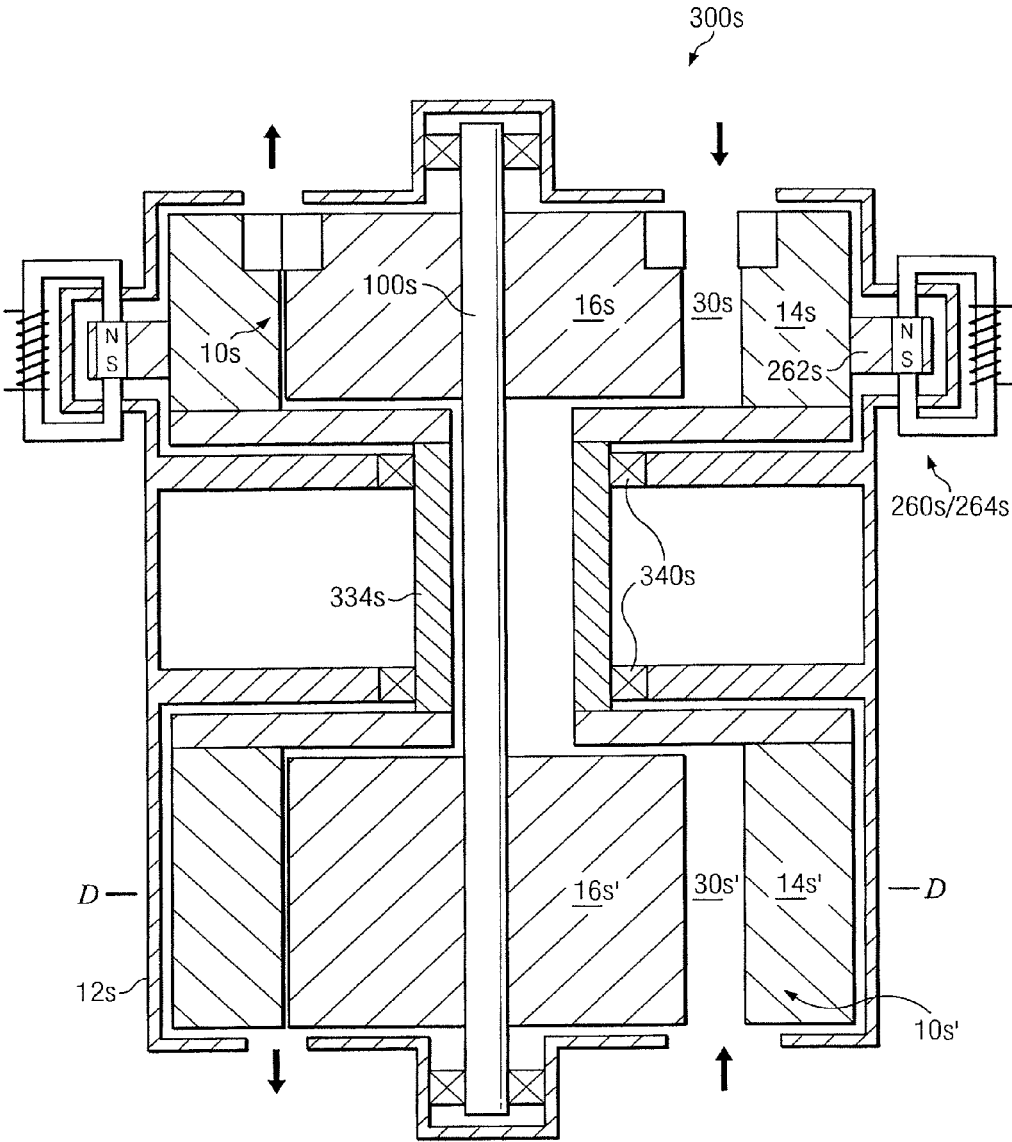

FIG. 24

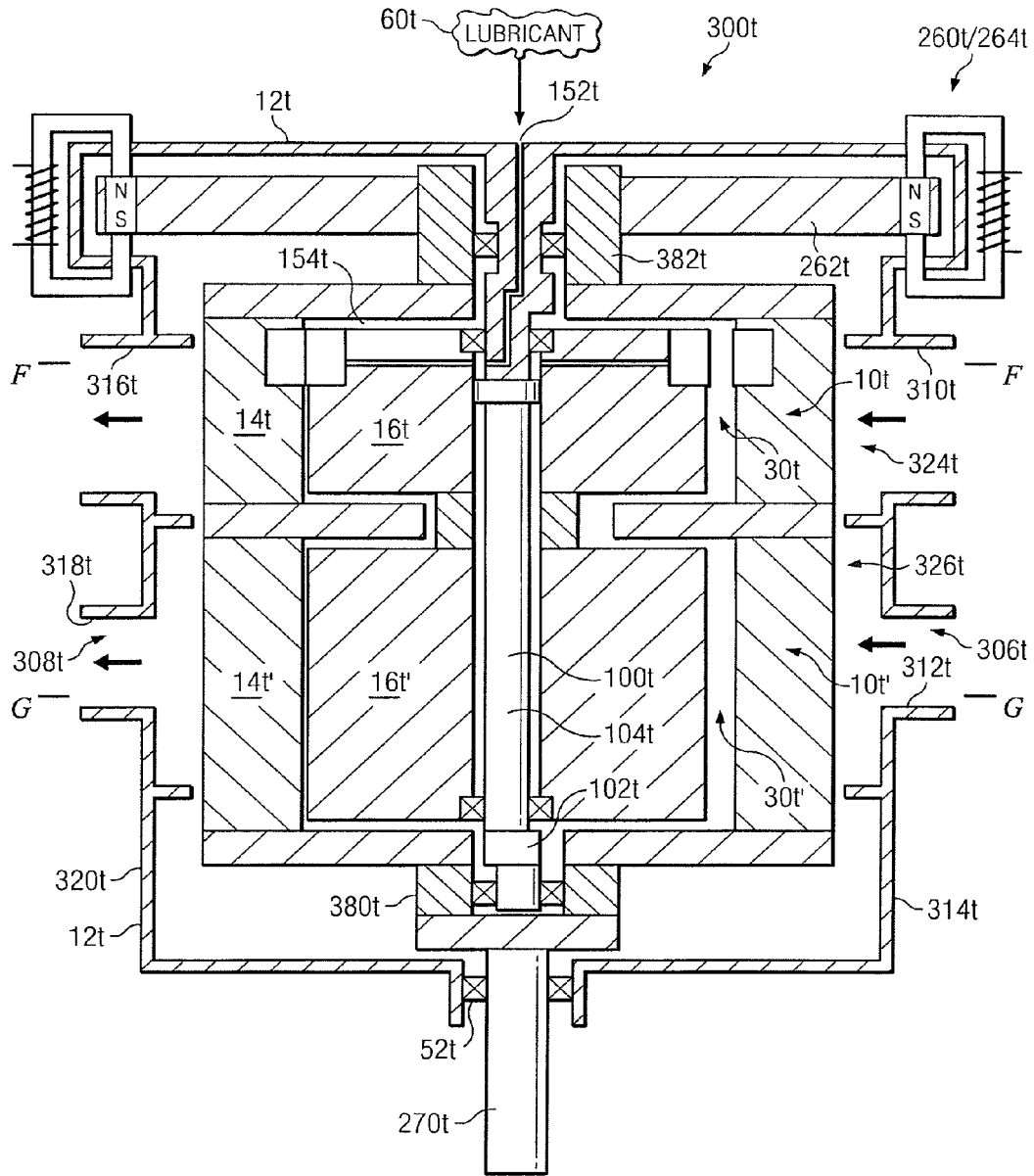

FIG. 25

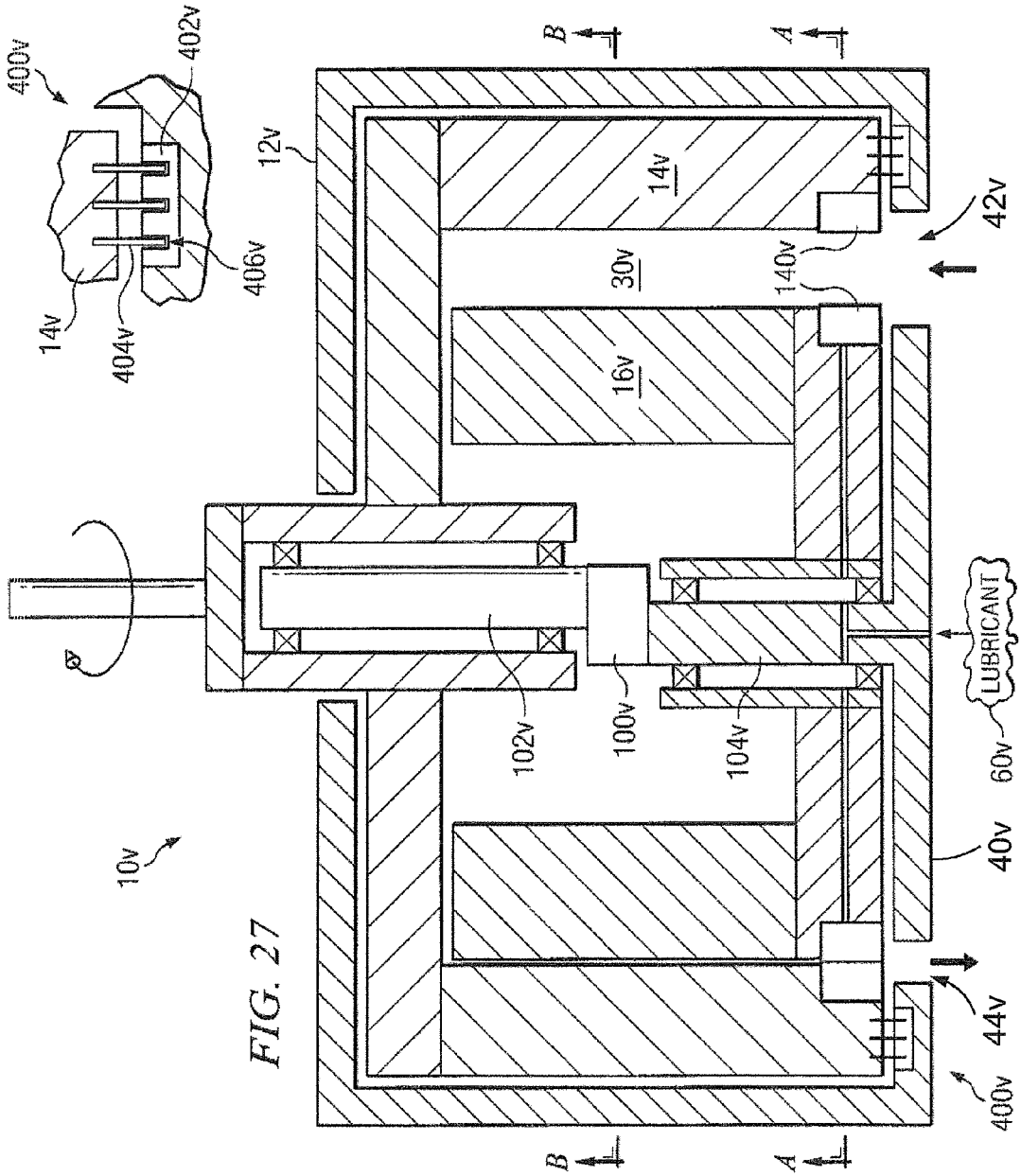
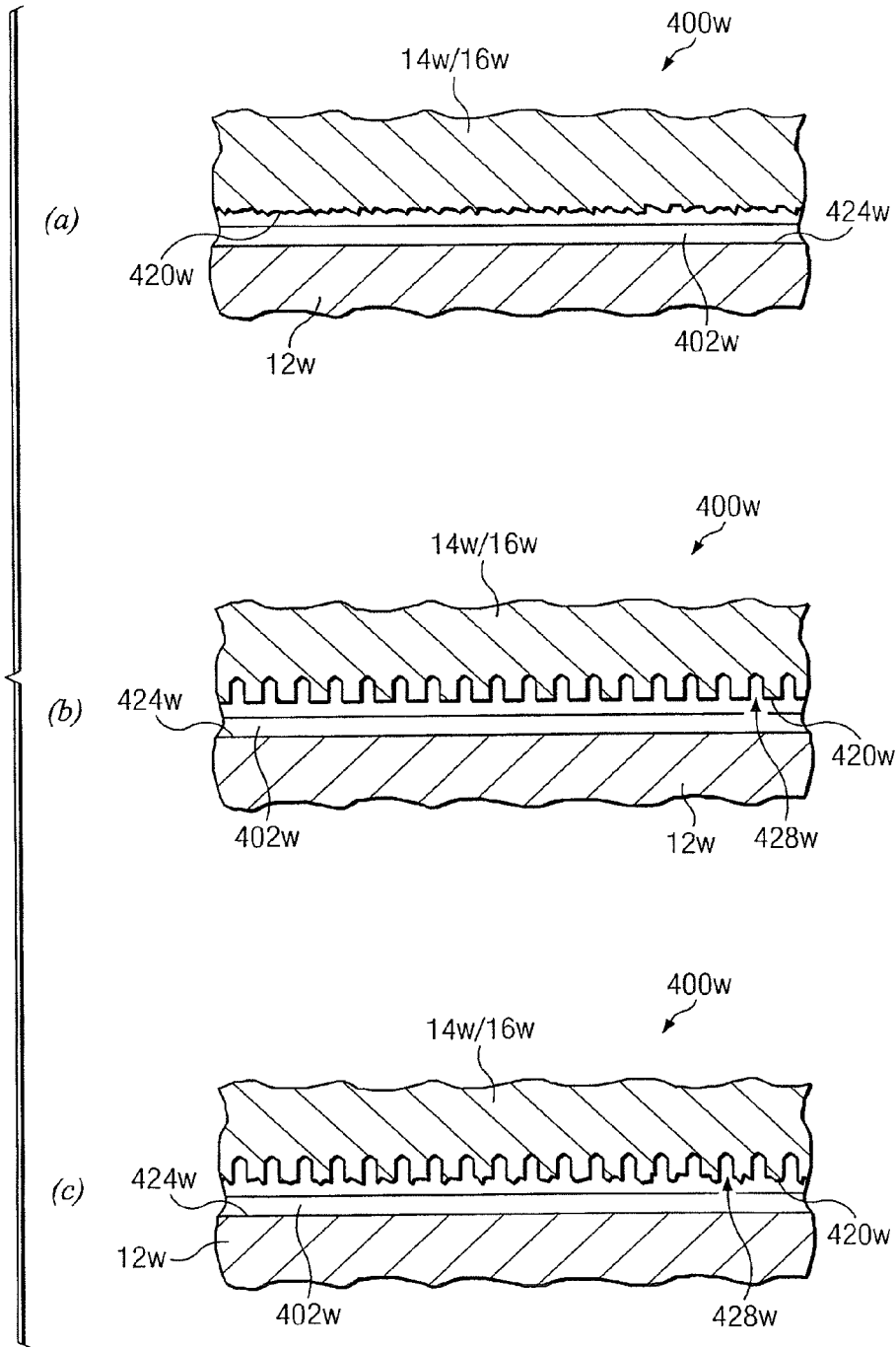

FIG. 28



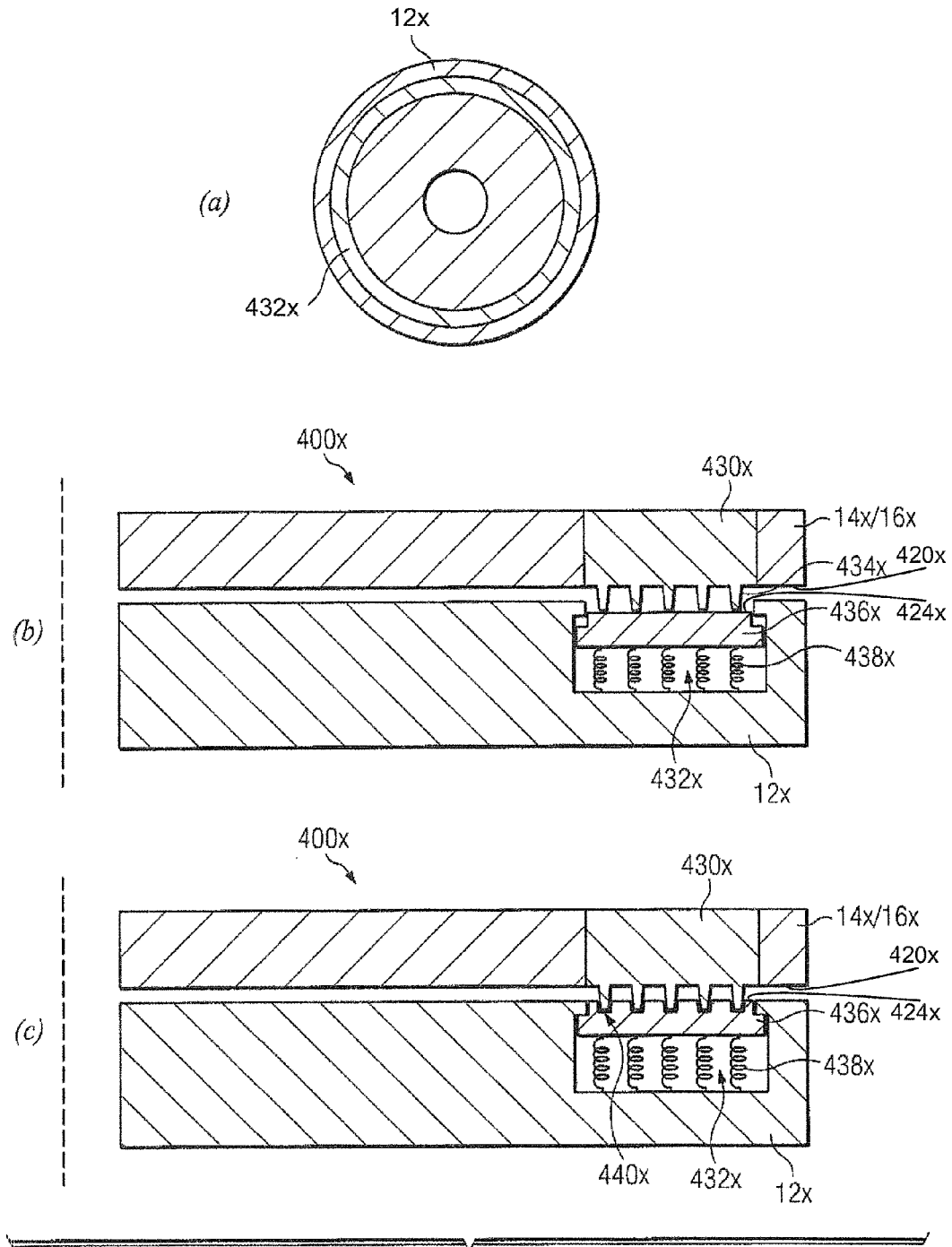

FIG. 29

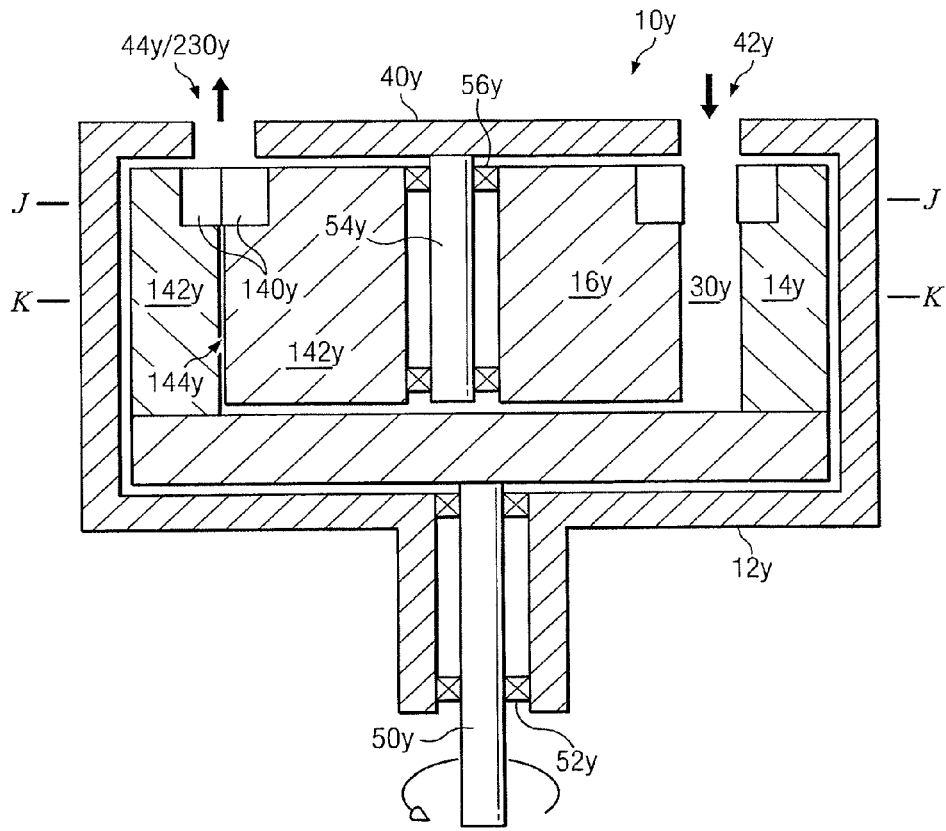

FIG. 30

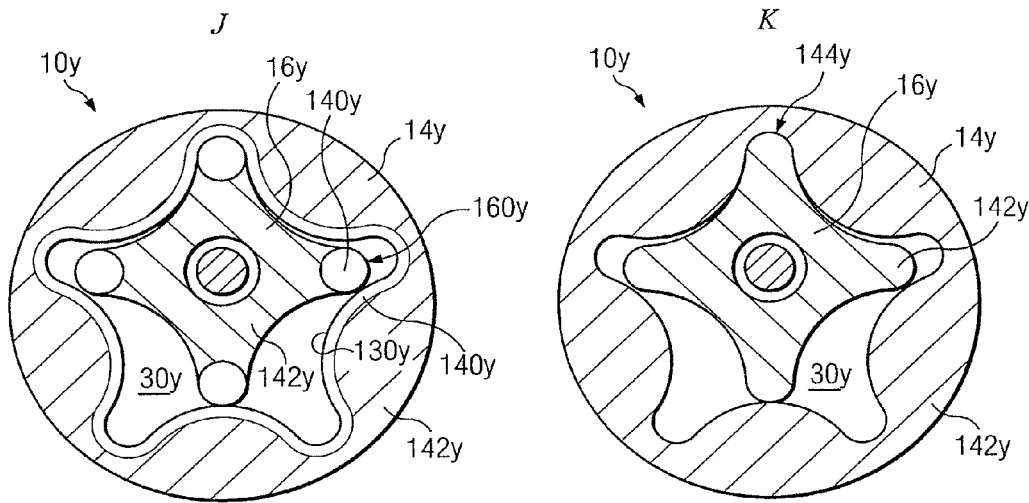

FIG. 31A

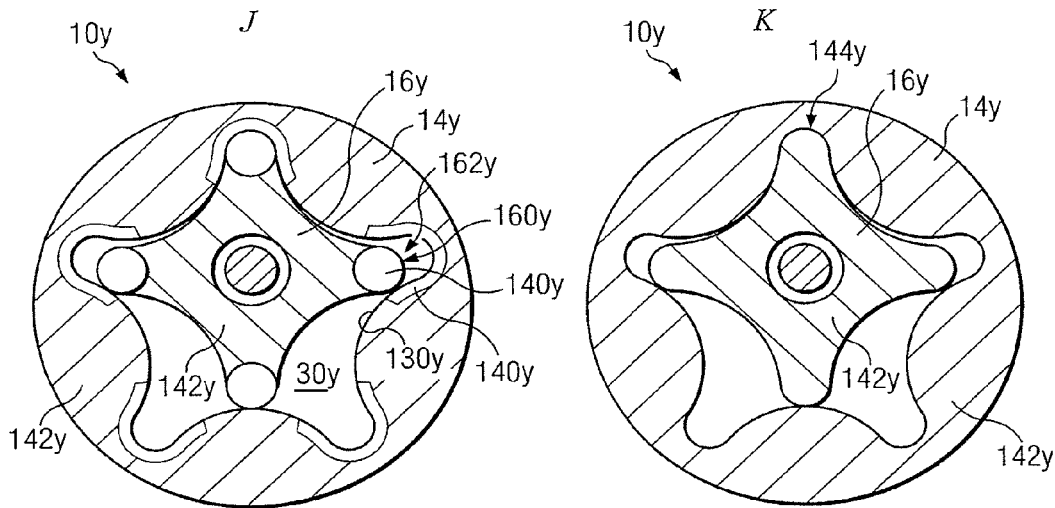

FIG. 31B

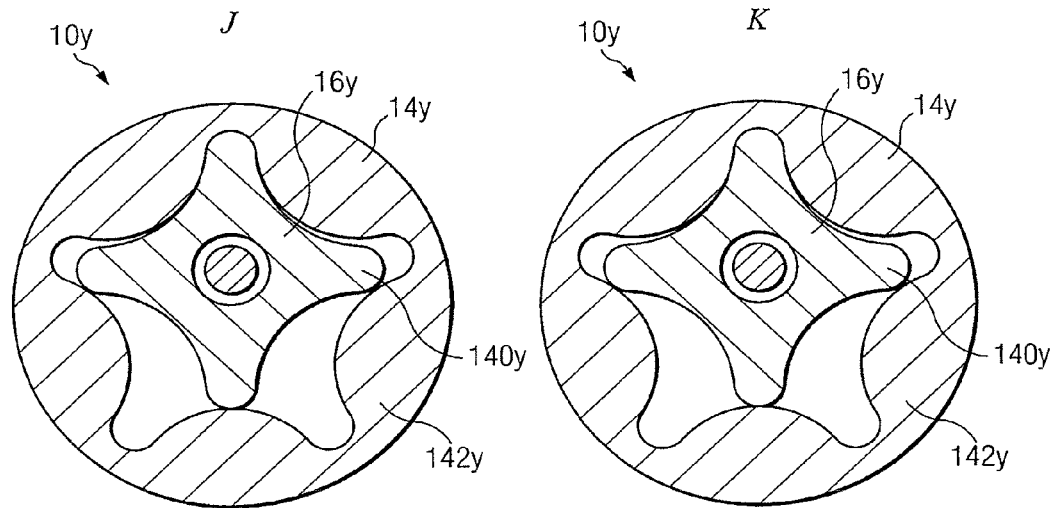

FIG. 31C

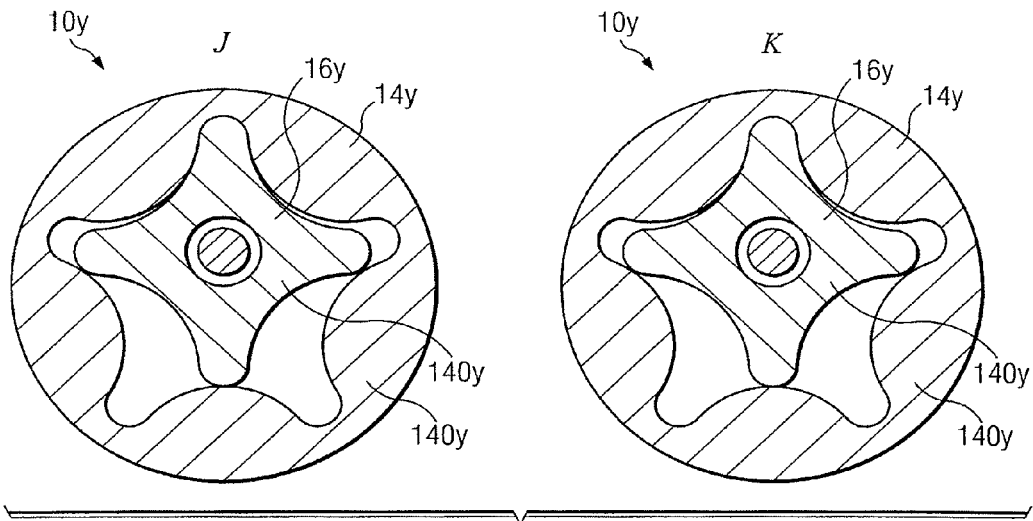

FIG. 31D

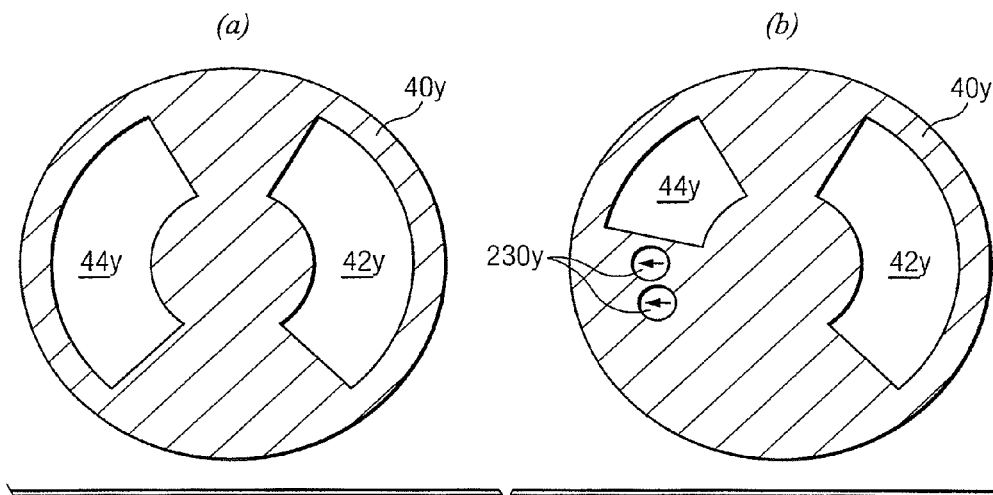

FIG. 32

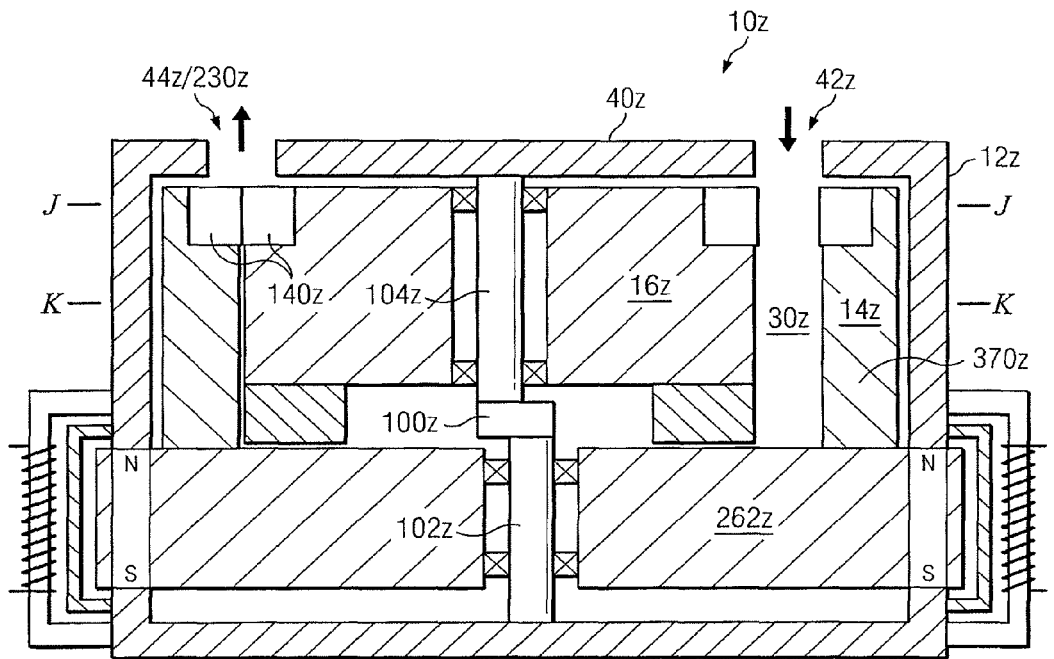

FIG. 33

260z/264z

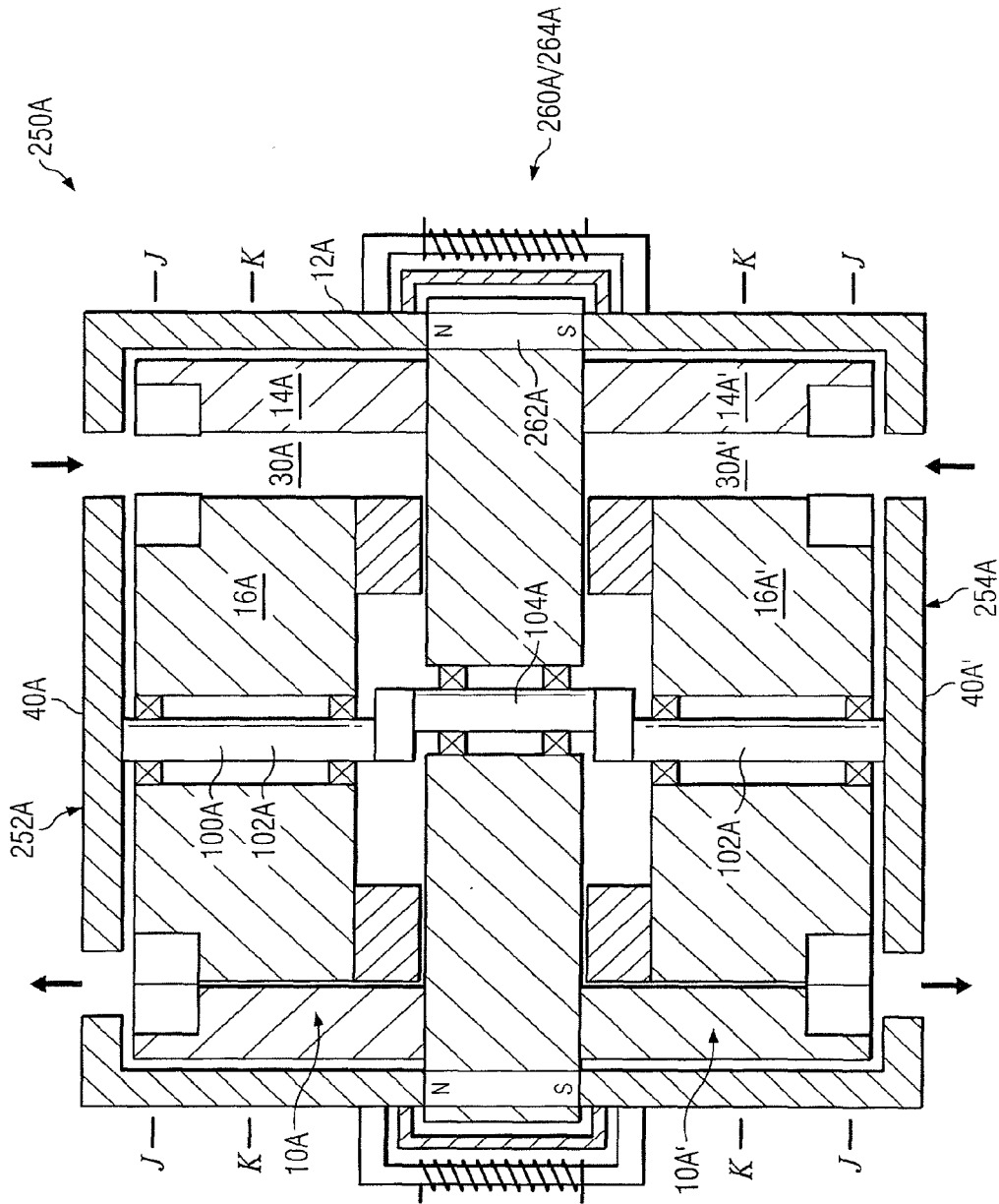

FIG. 34

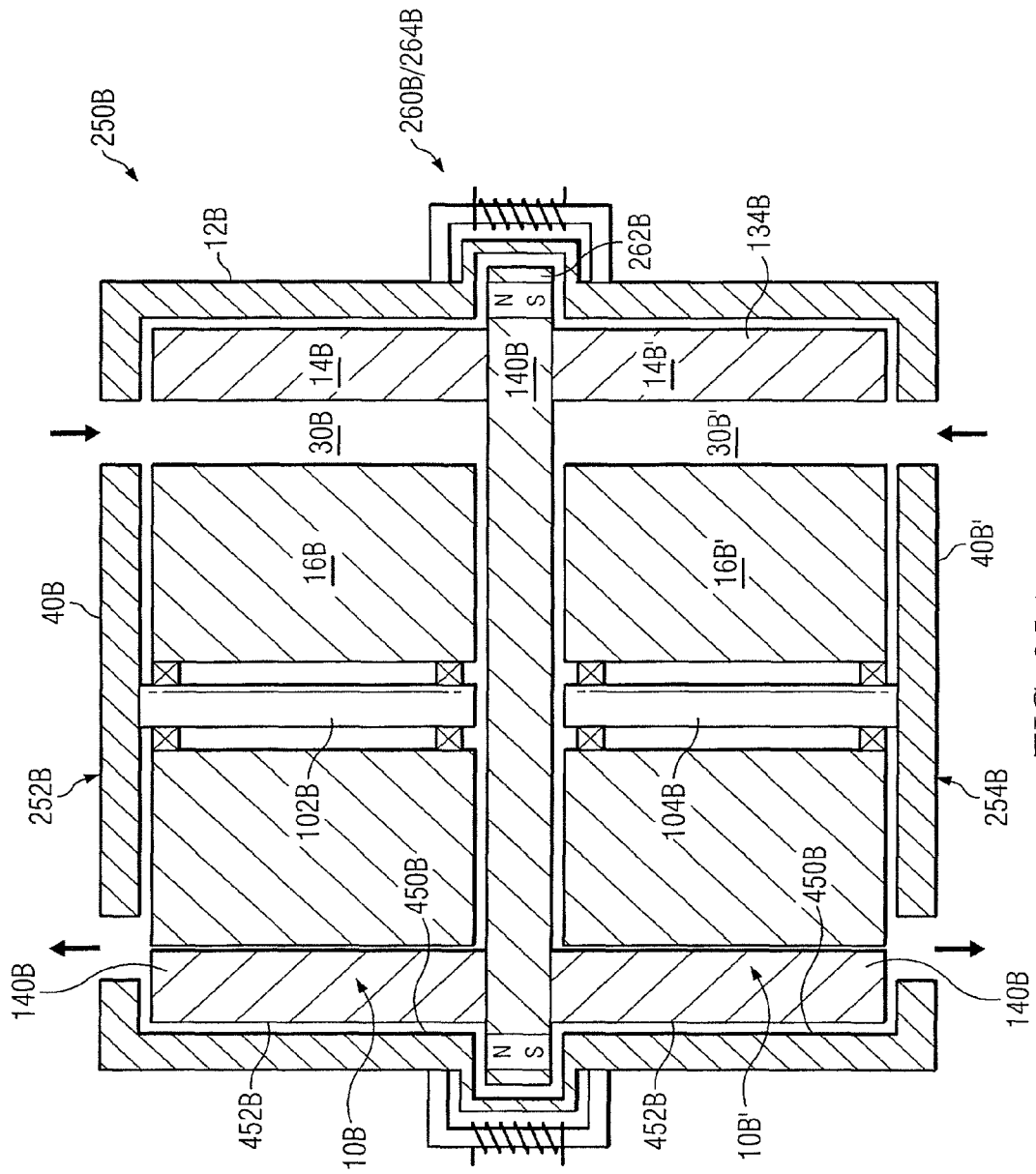

FIG. 35A

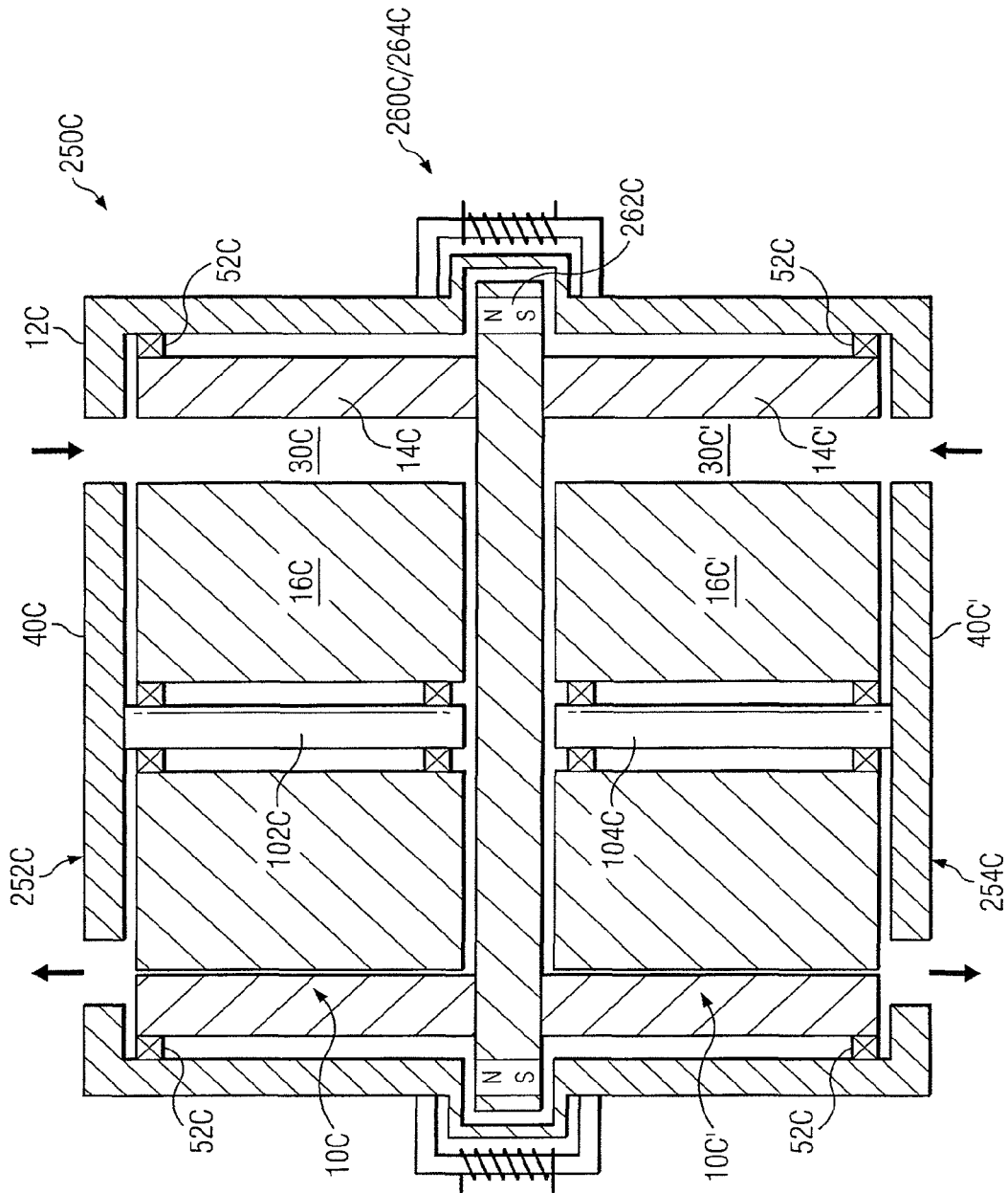

FIG. 35B

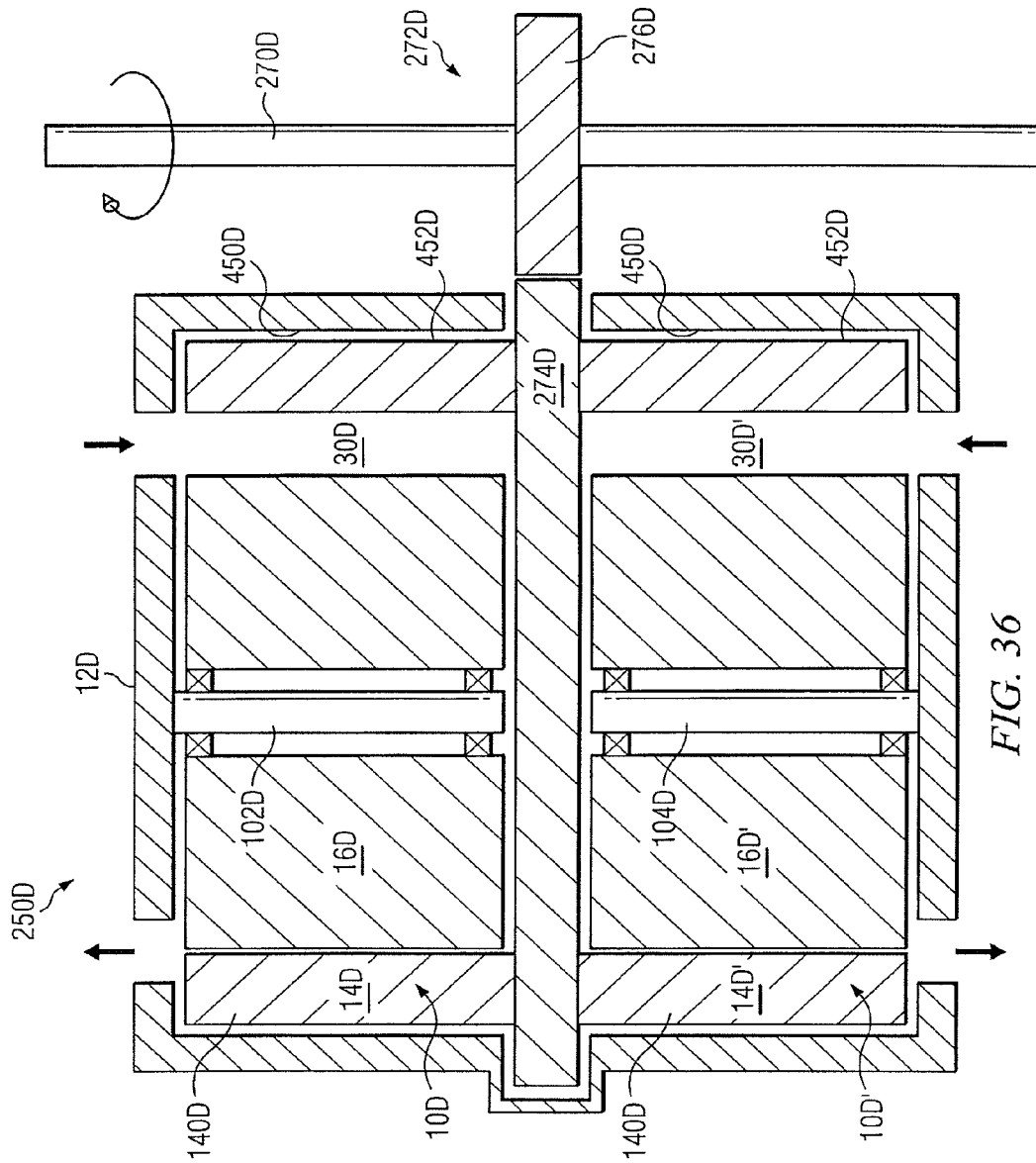

FIG. 36

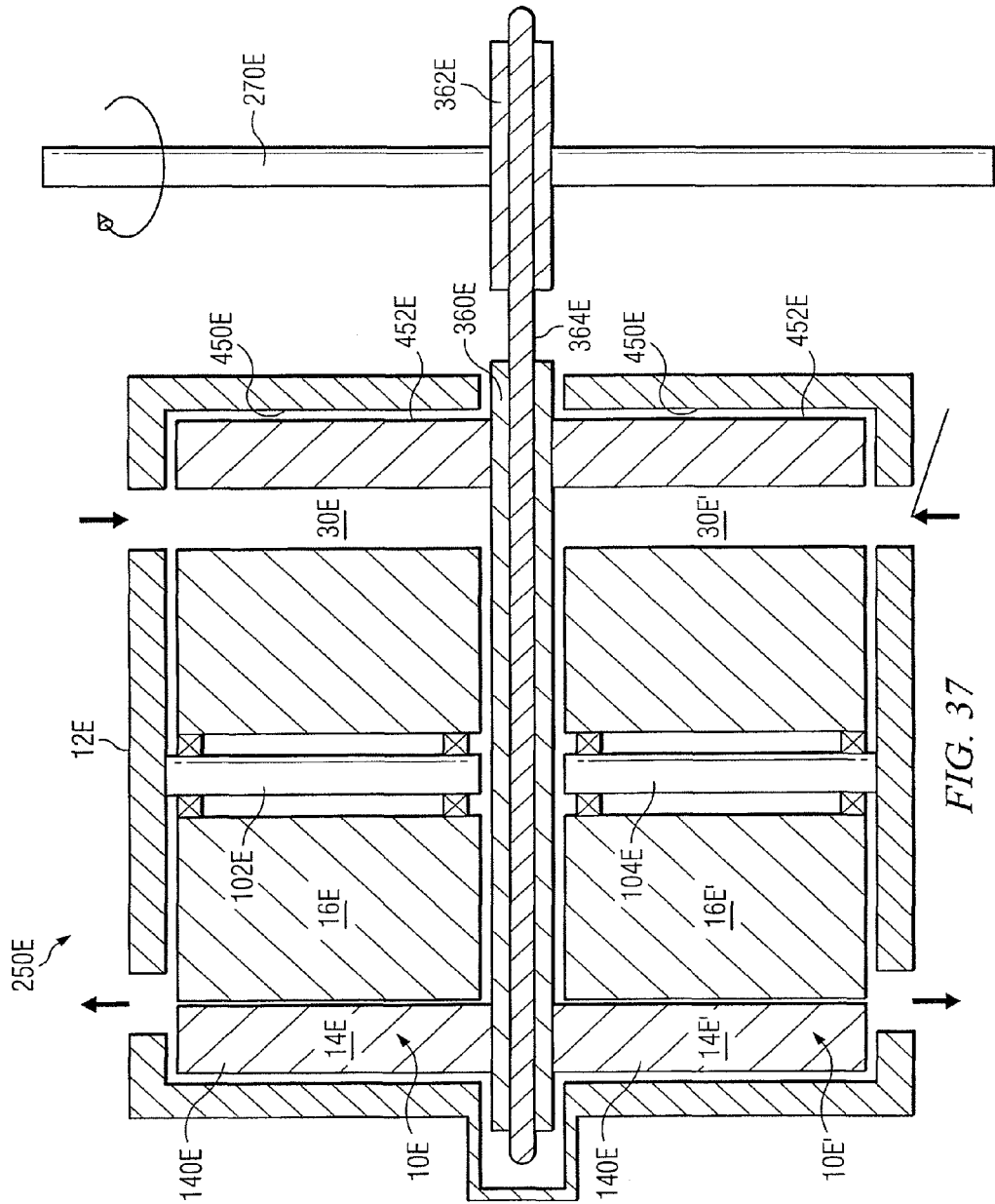

FIG. 37

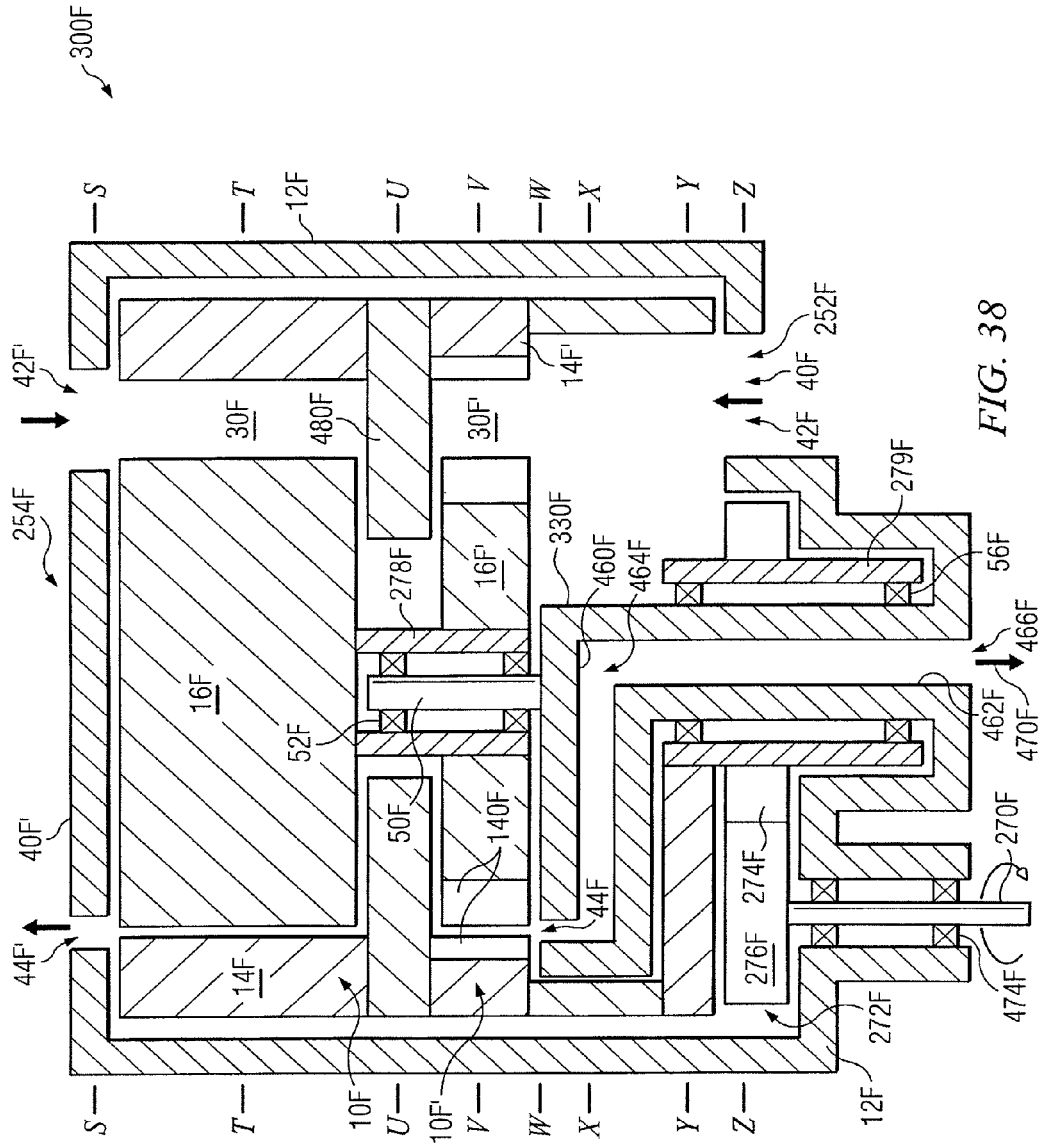

FIG. 38

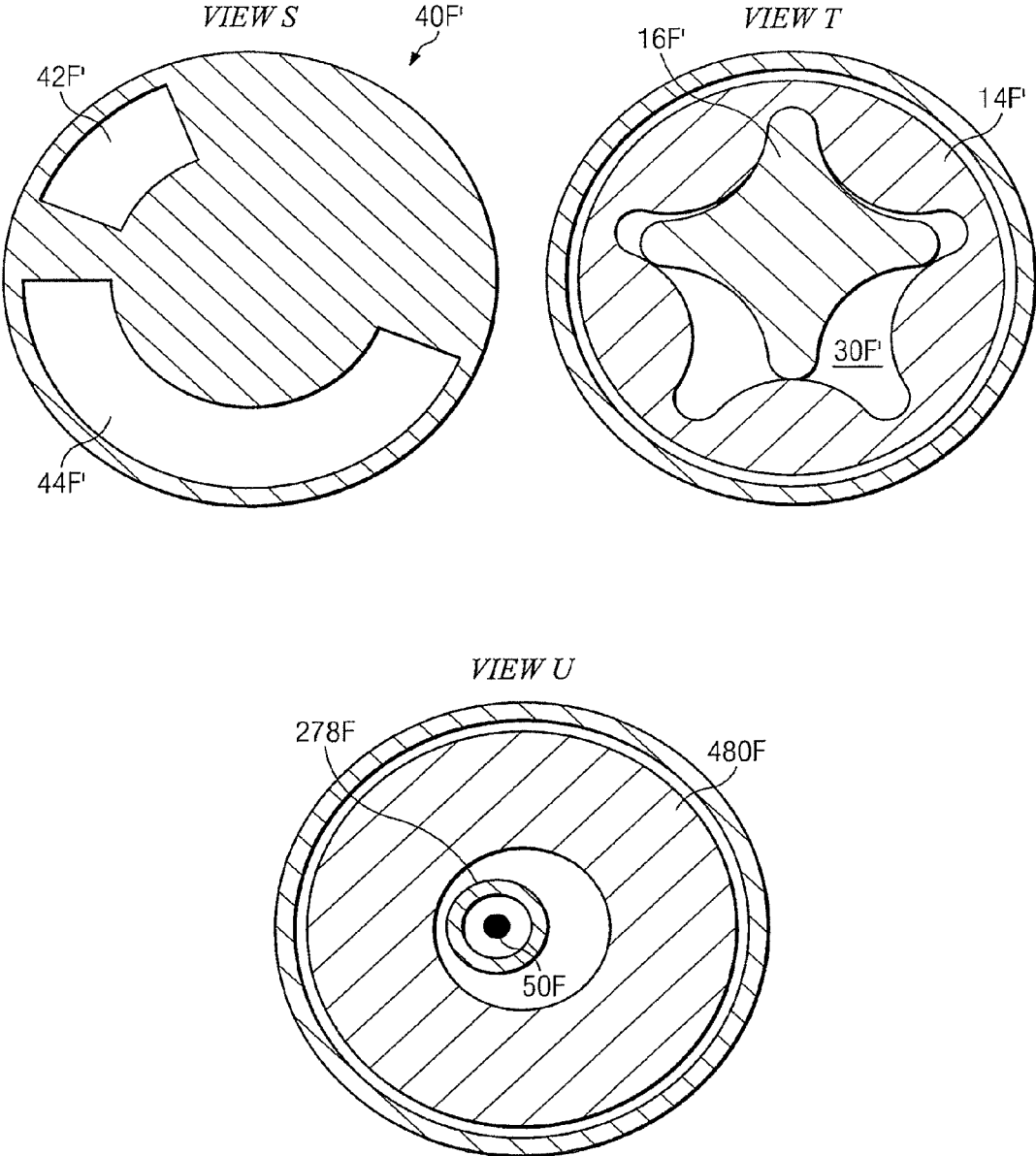
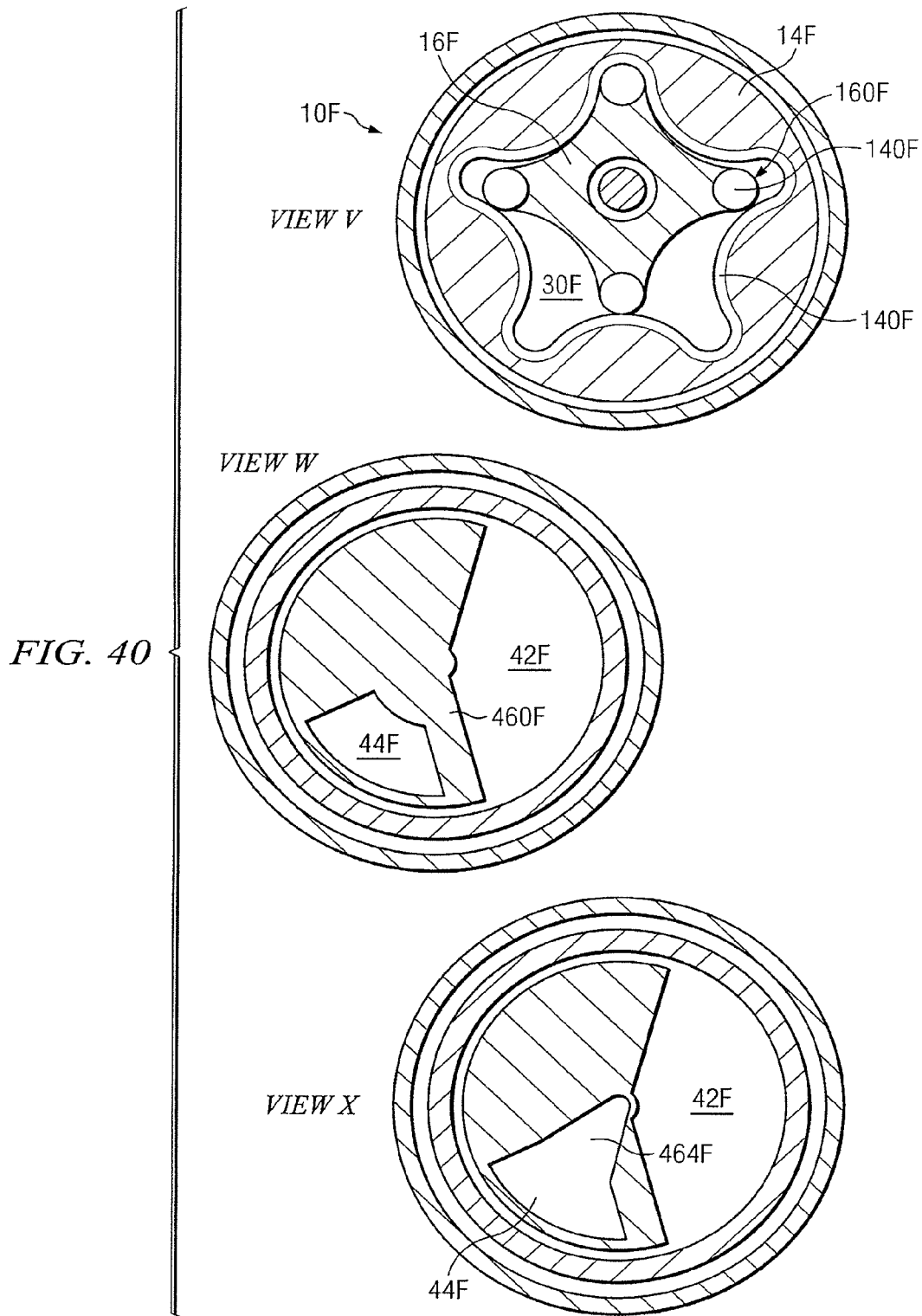
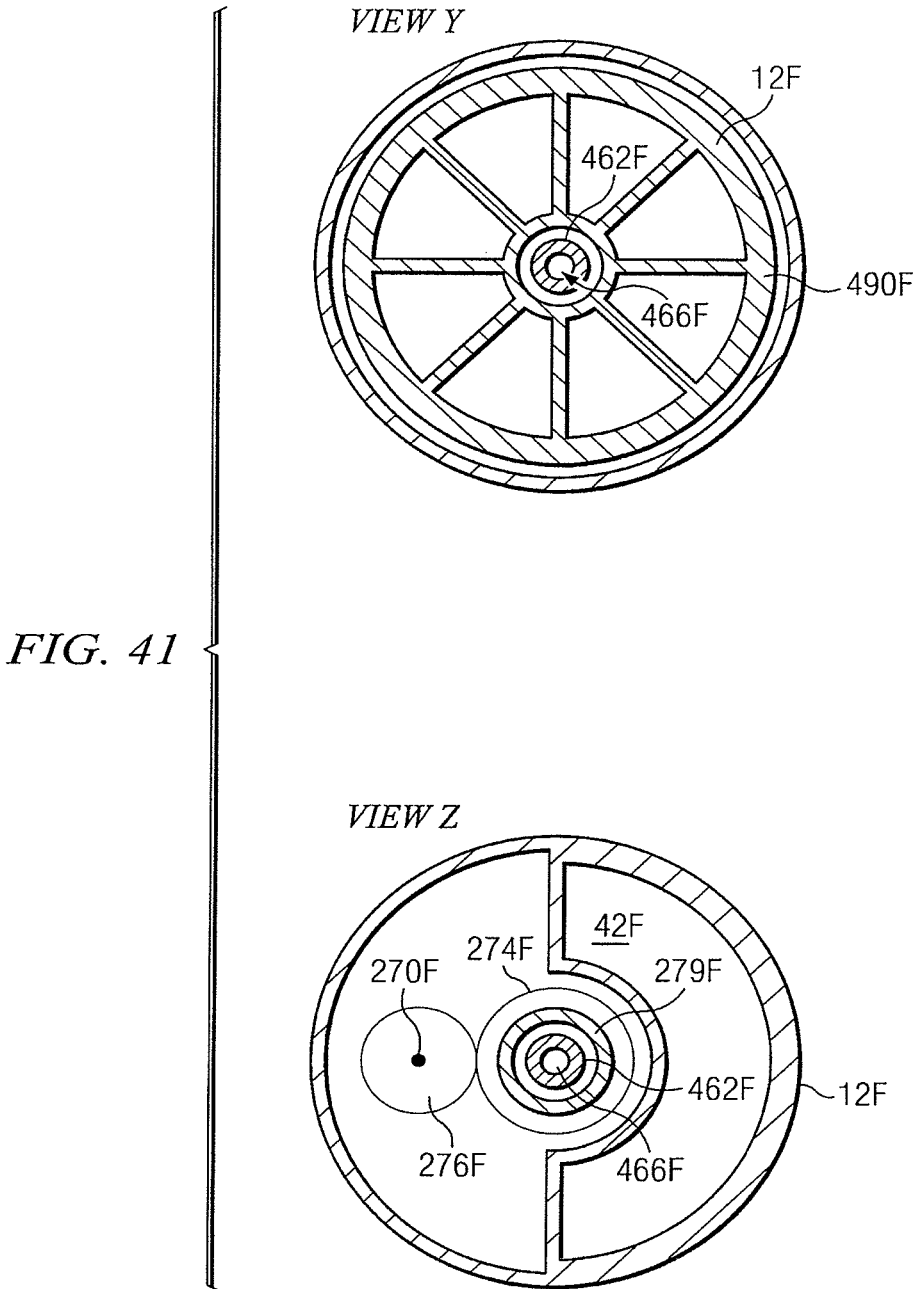
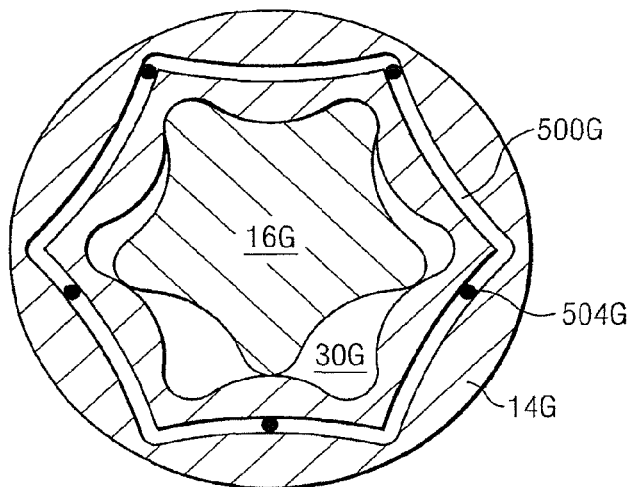
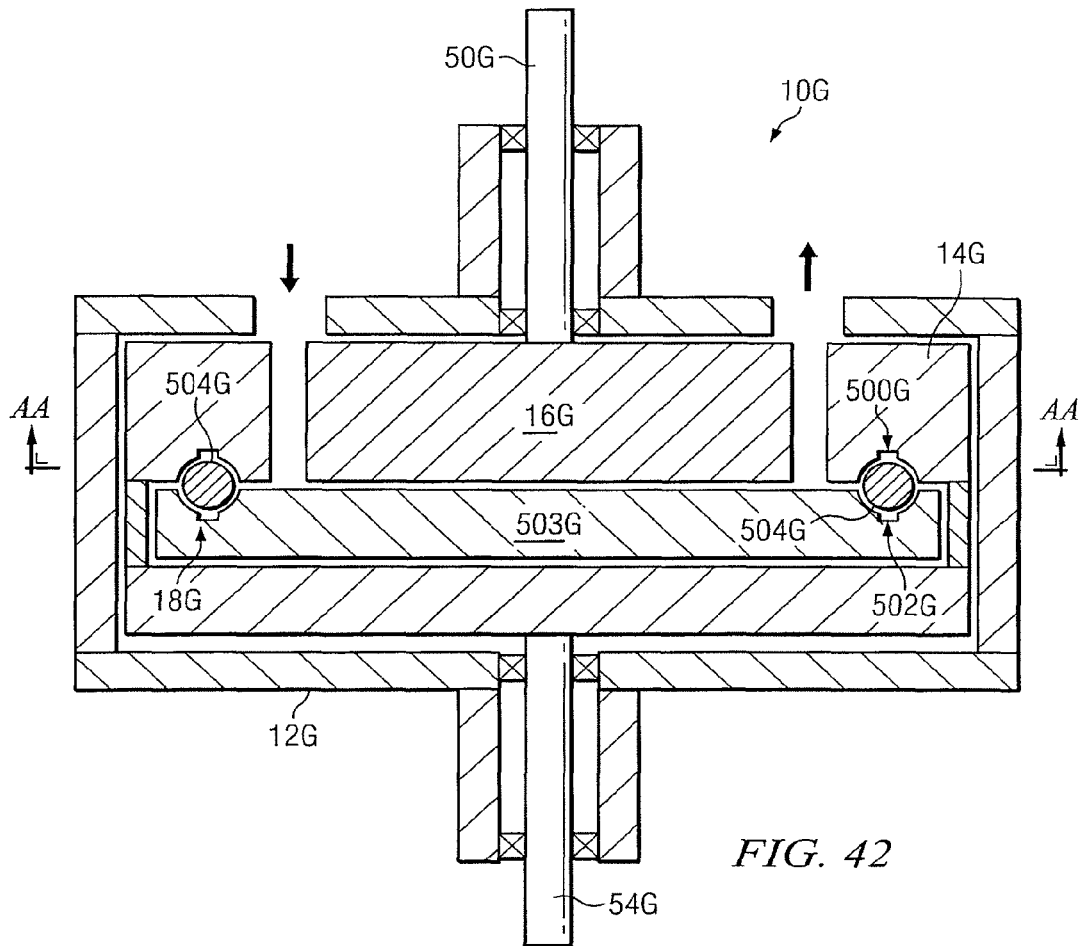

FIG. 39







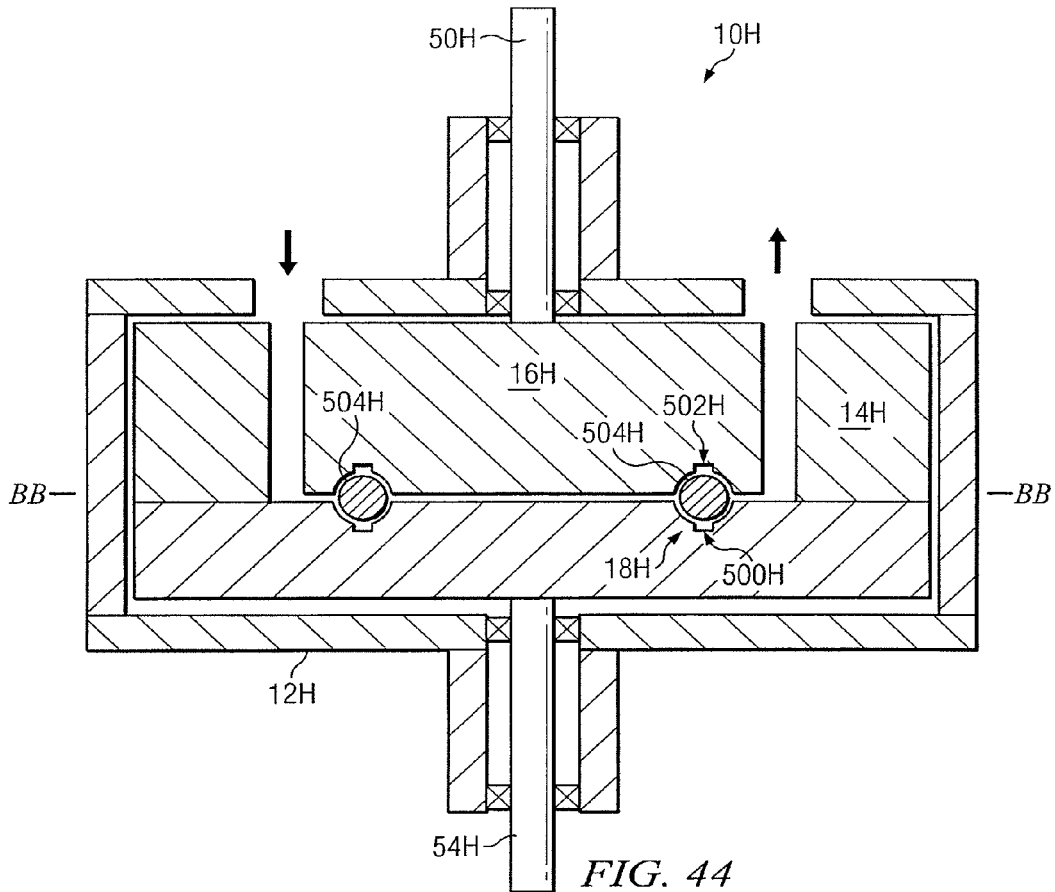

FIG. 44

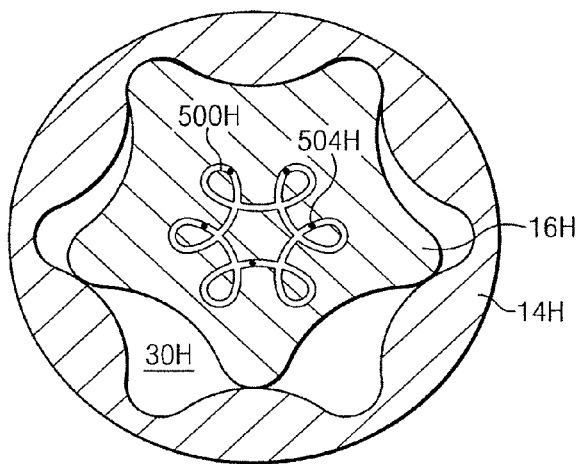

FIG. 45

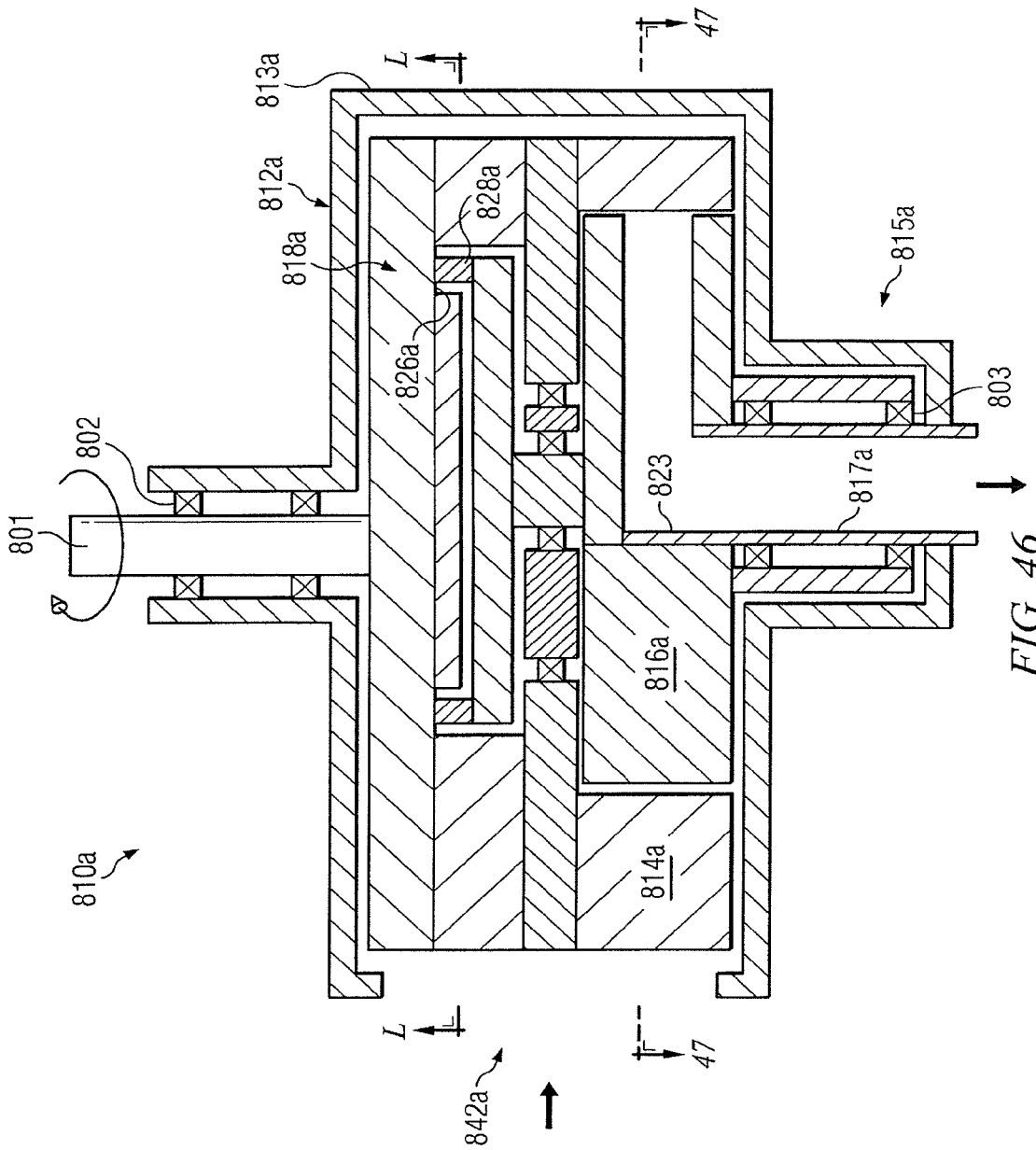

FIG. 46

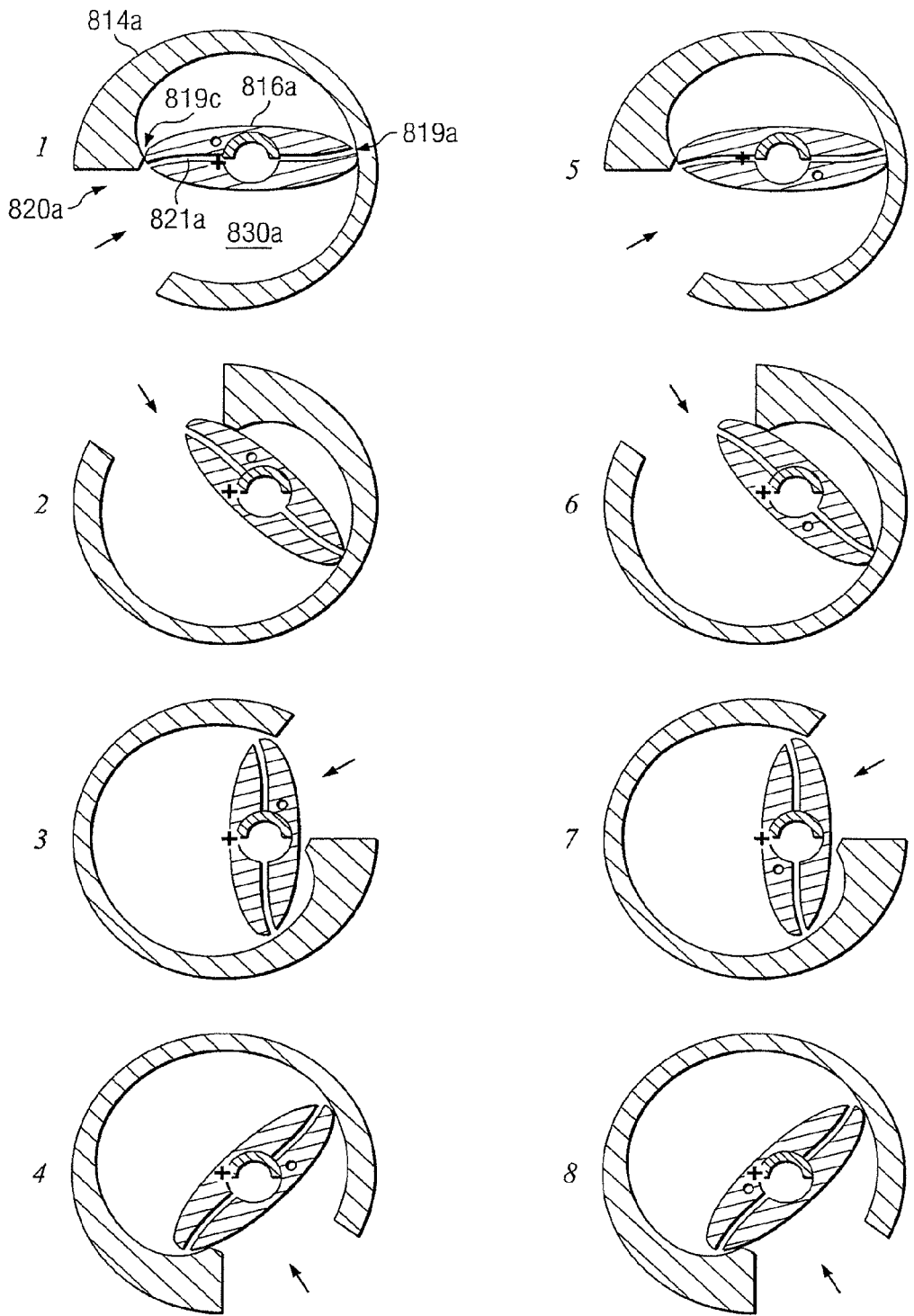

FIG. 47

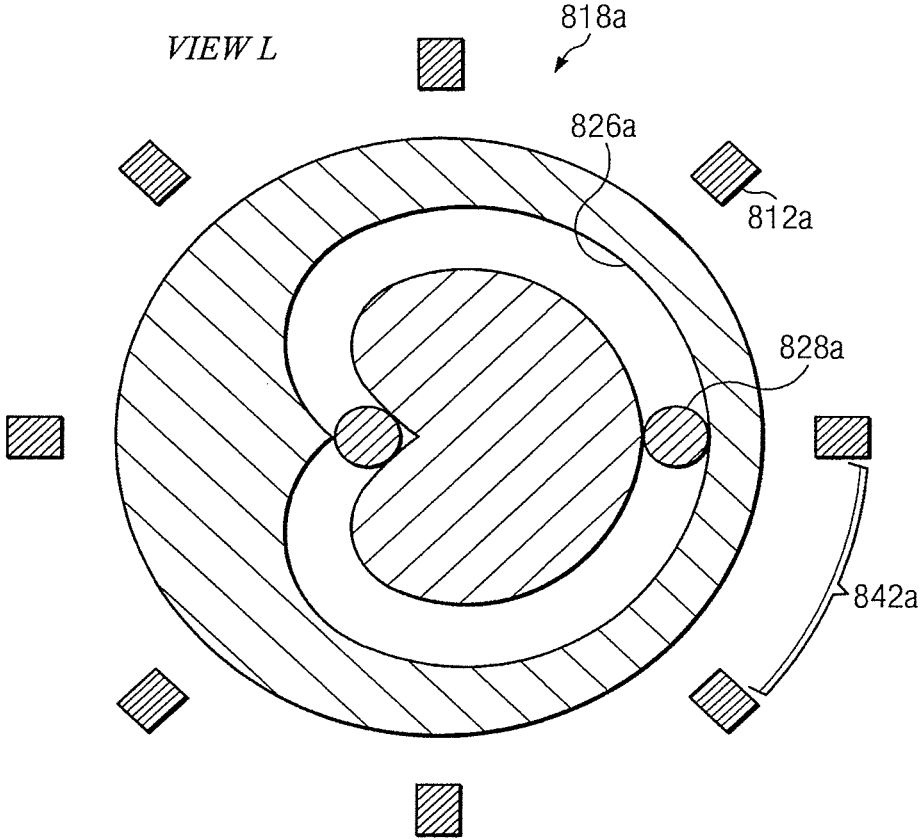

FIG. 48

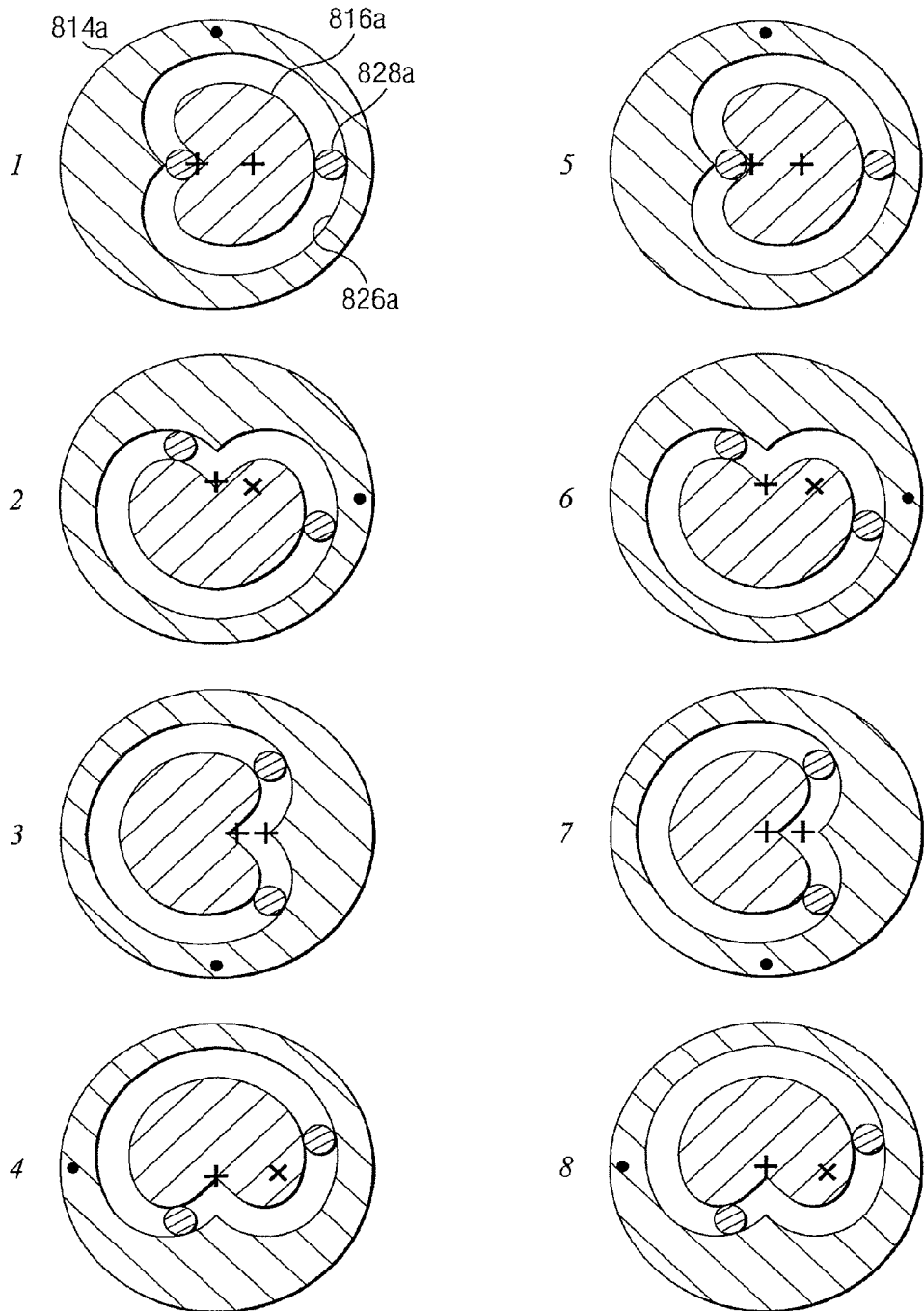

FIG. 49

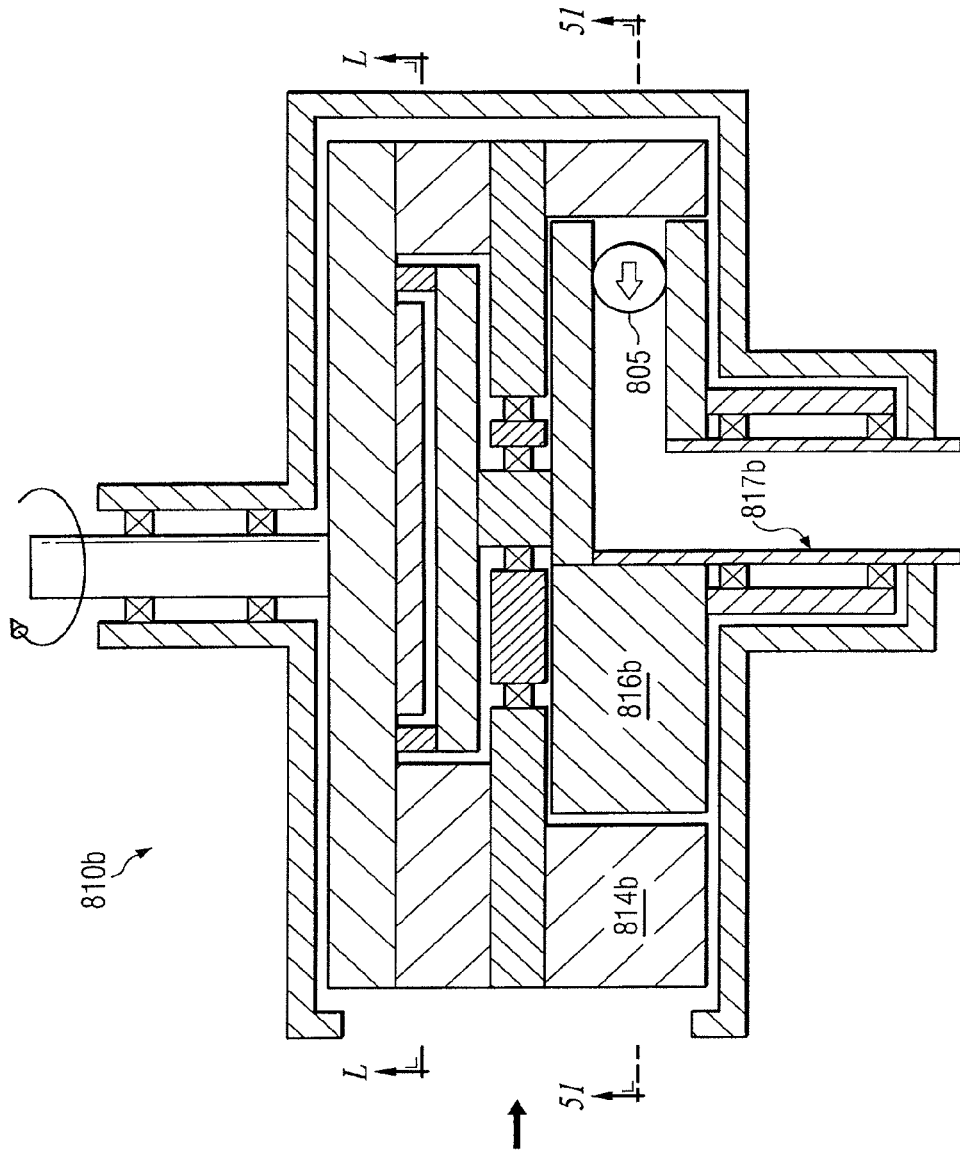

FIG. 50

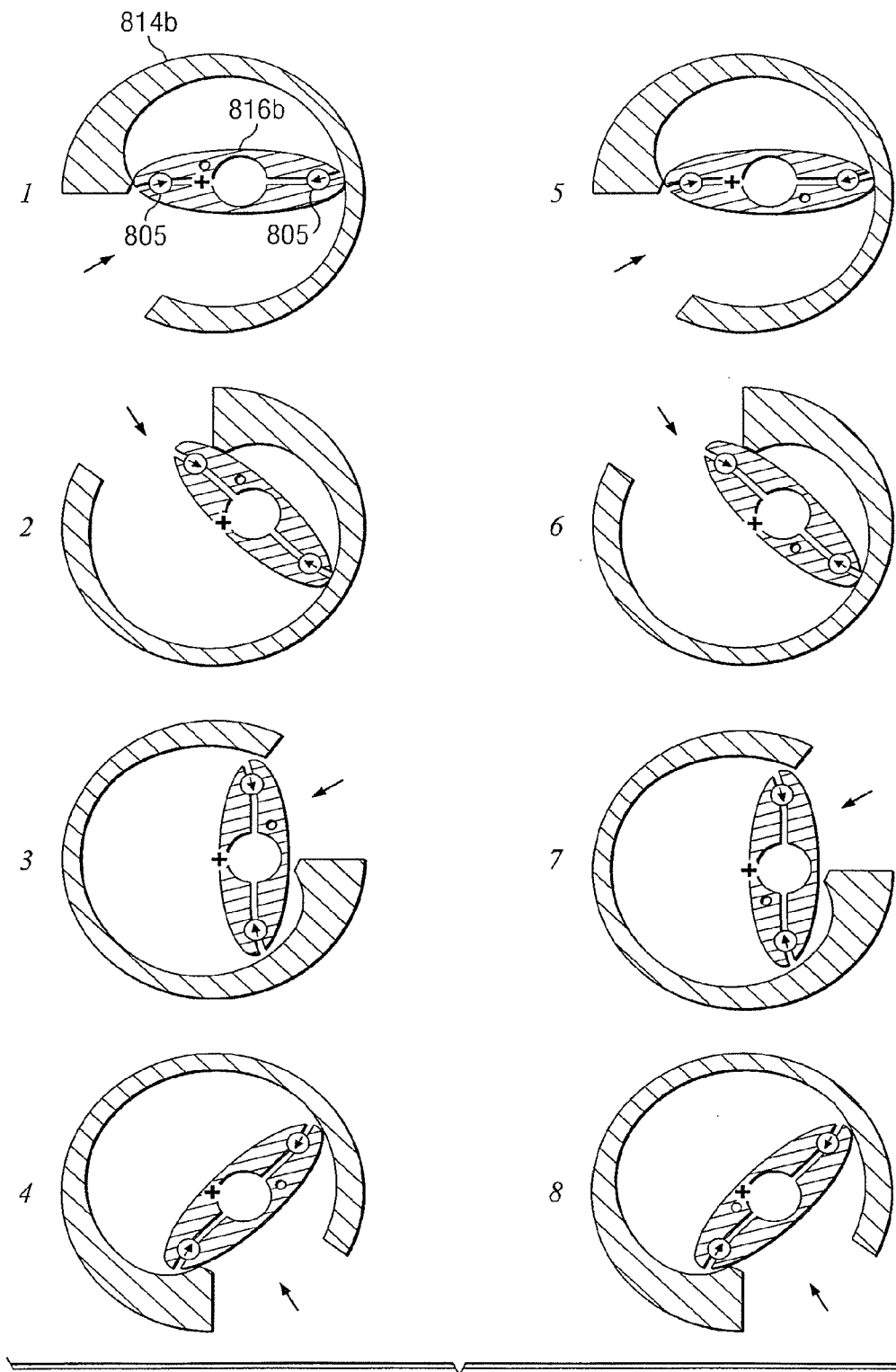

FIG. 51

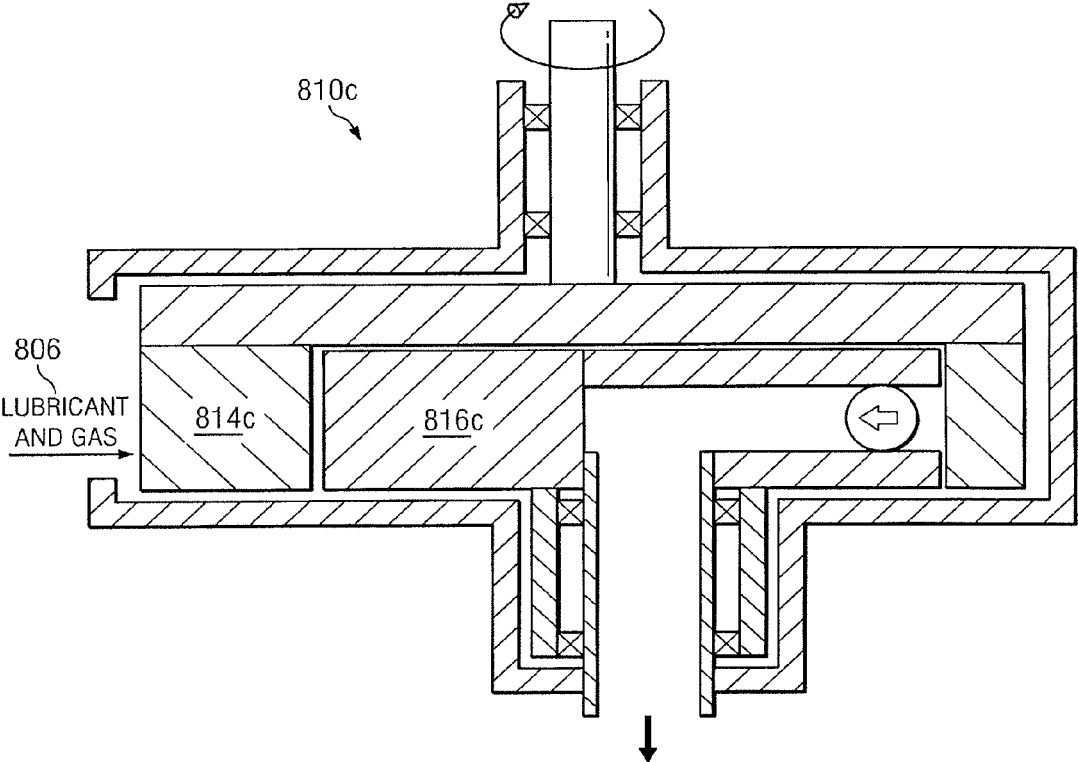

FIG. 52

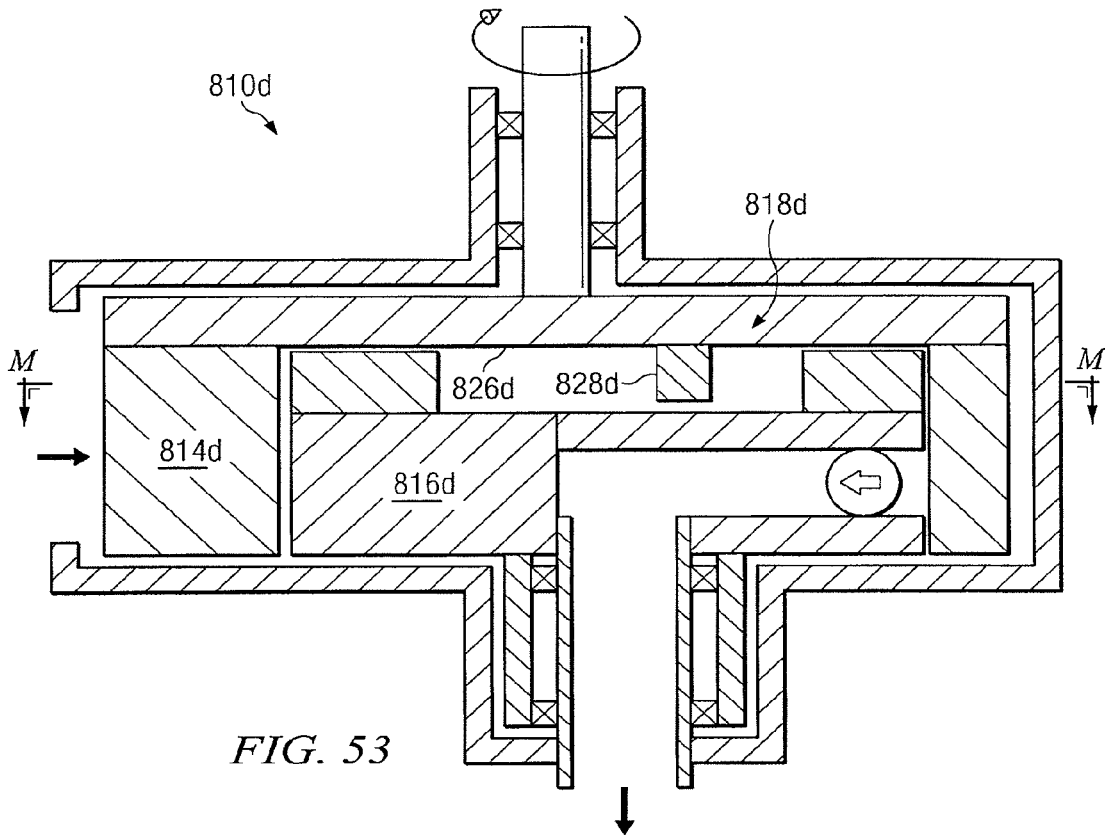

FIG. 53

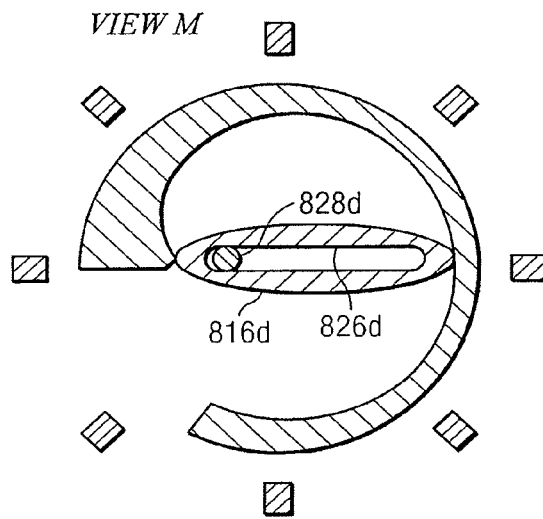

FIG. 54

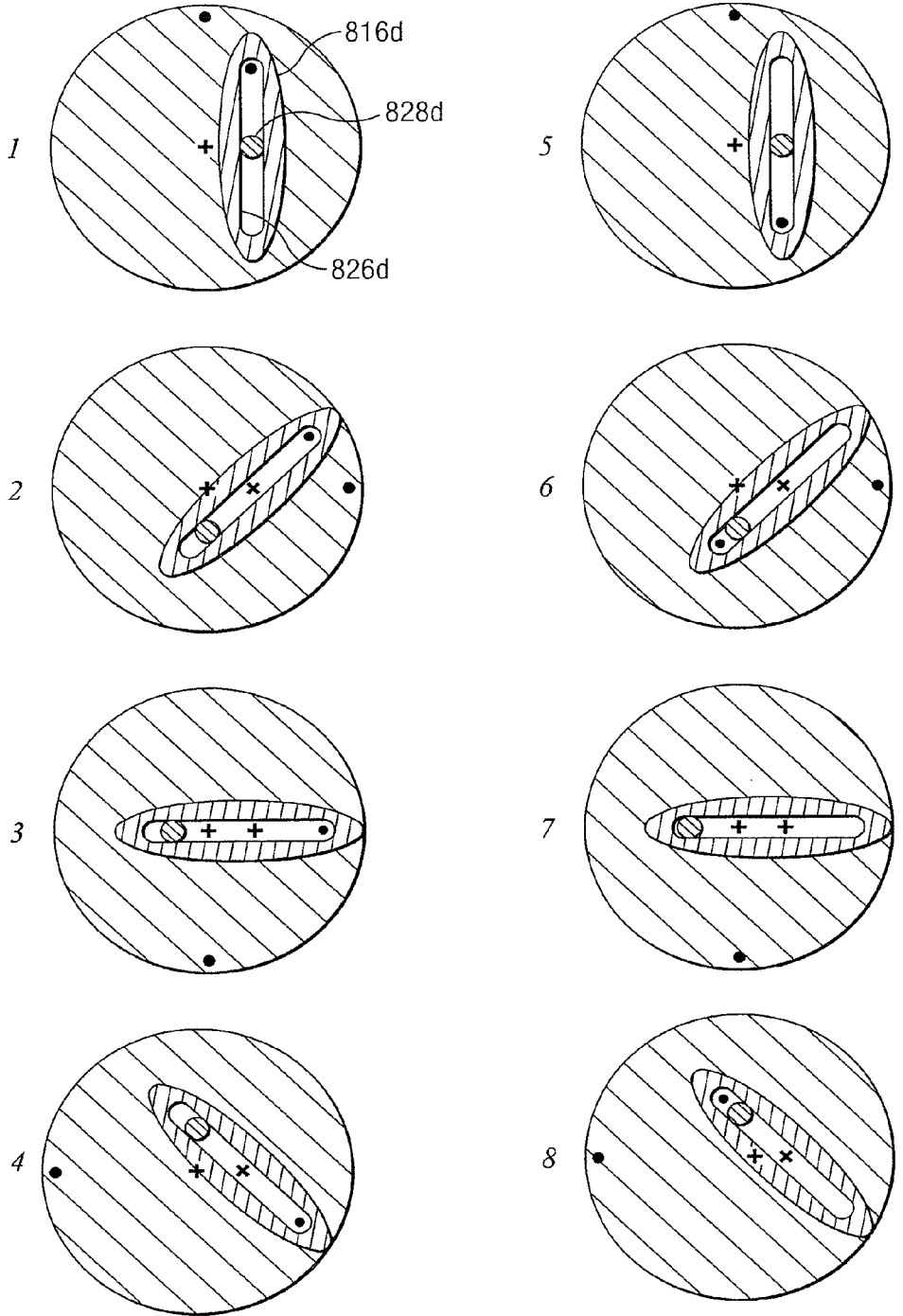

FIG. 55

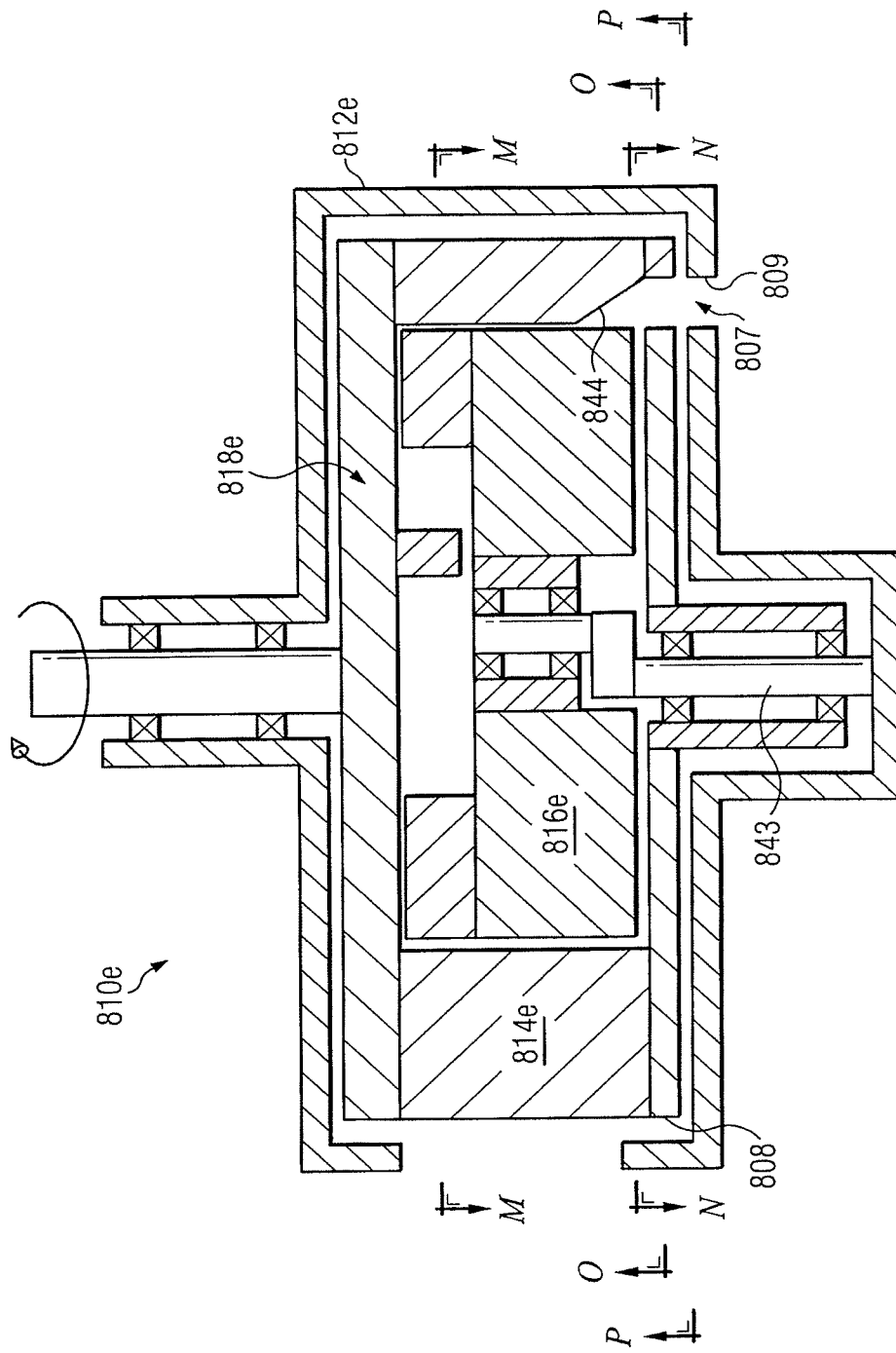

FIG. 56

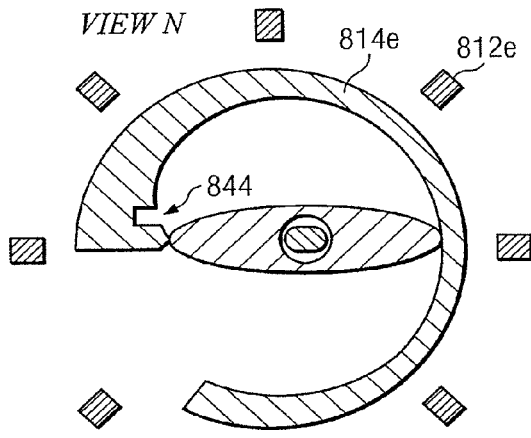

FIG. 57

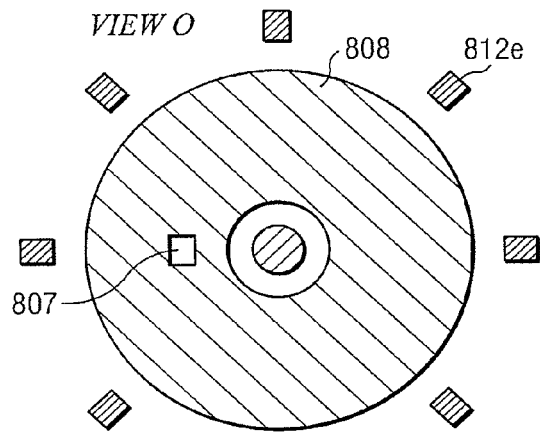

FIG. 58

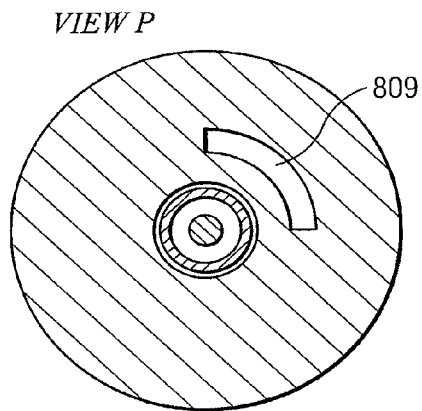

FIG. 59

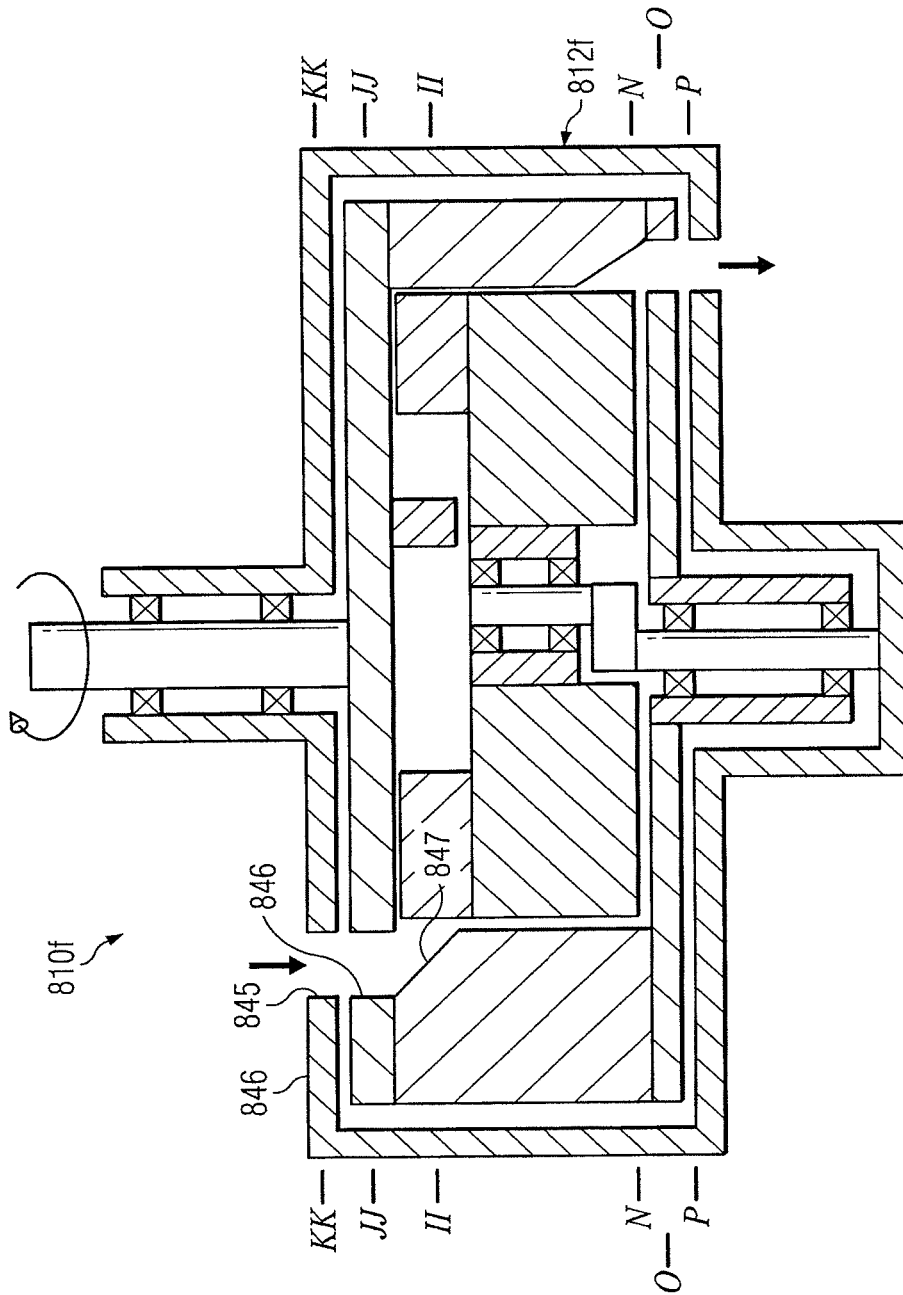
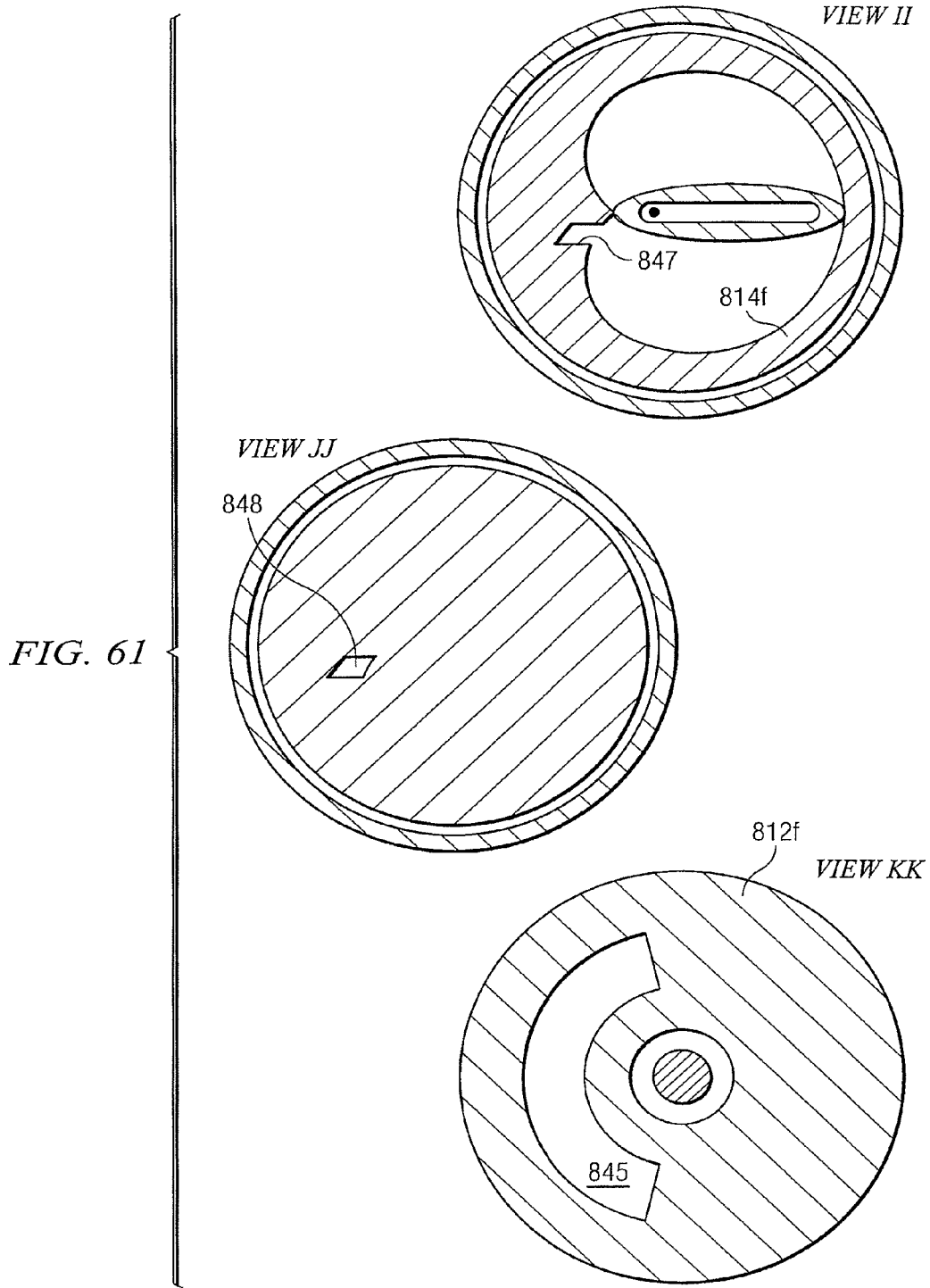

FIG. 60



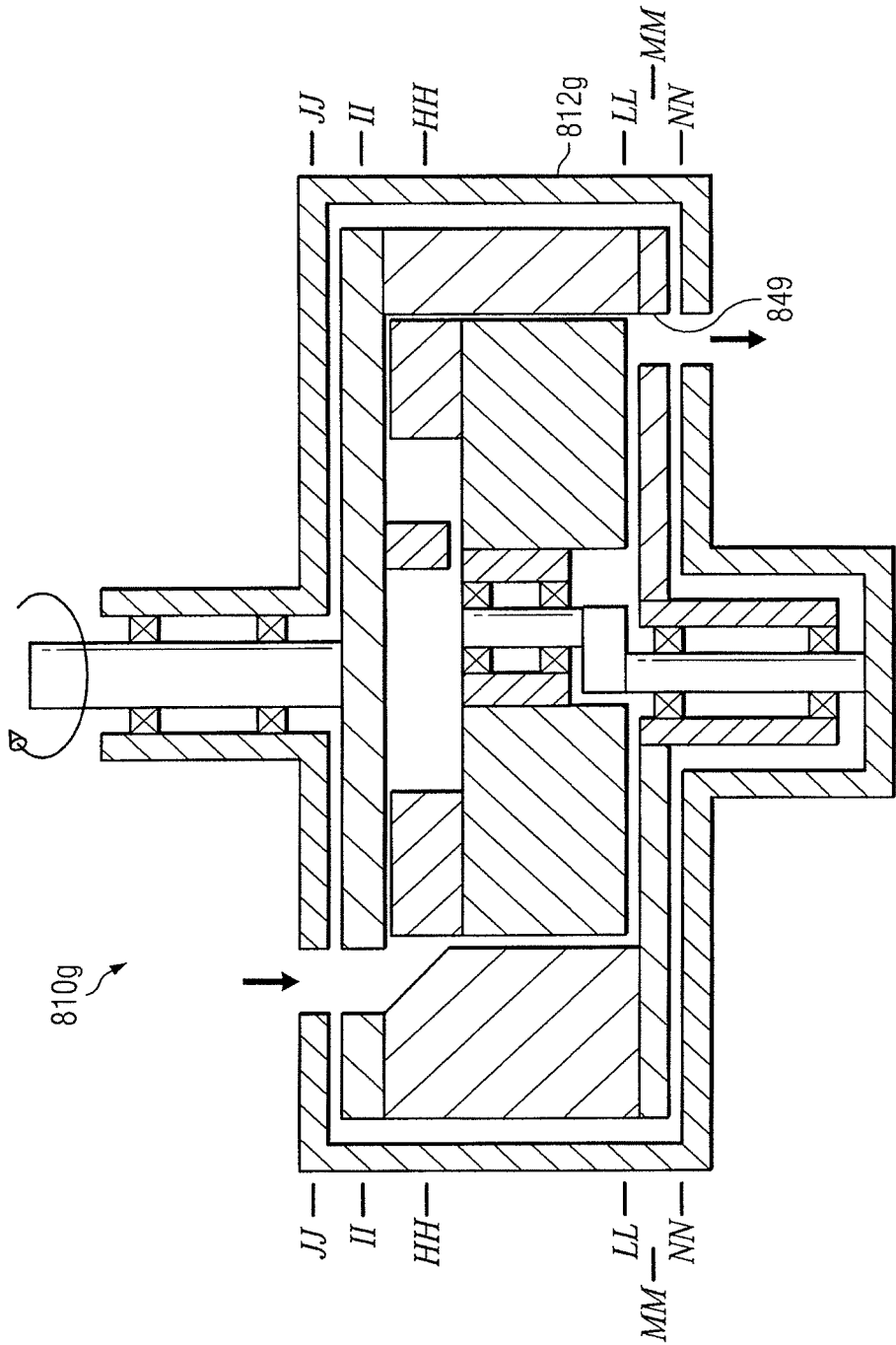
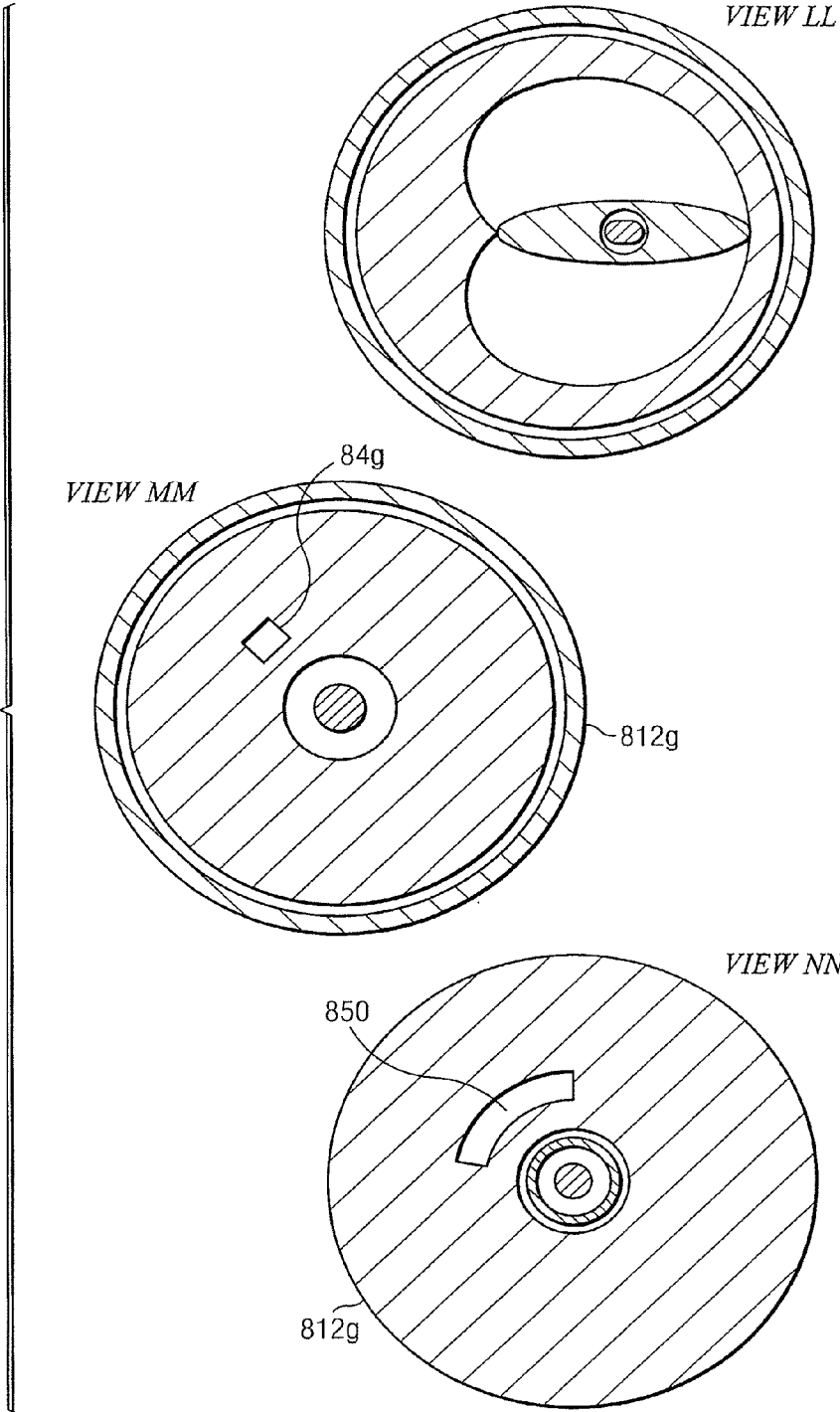

FIG. 62

FIG. 63



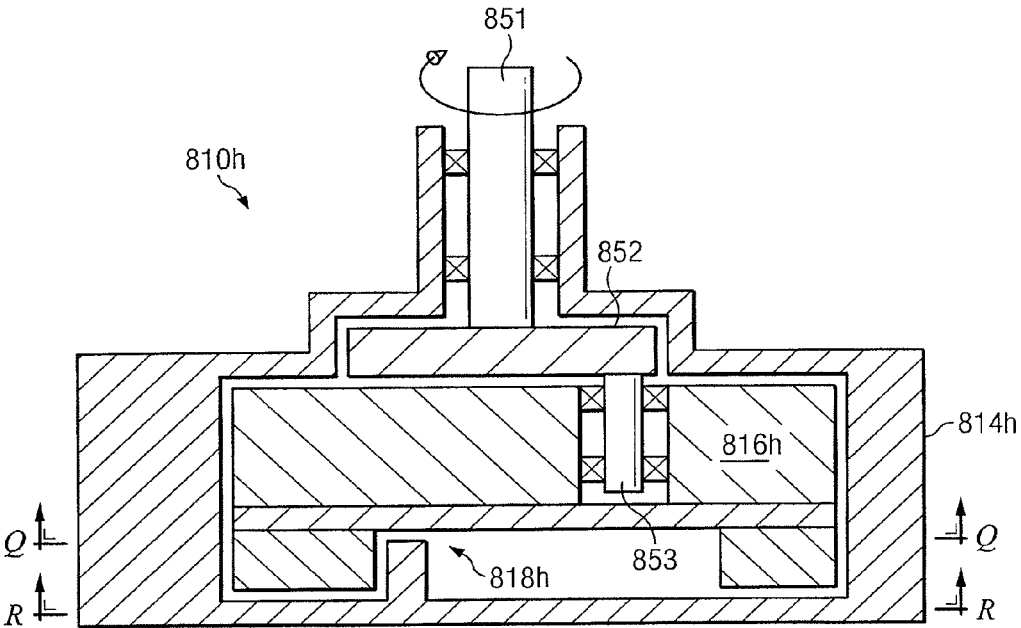

FIG. 64

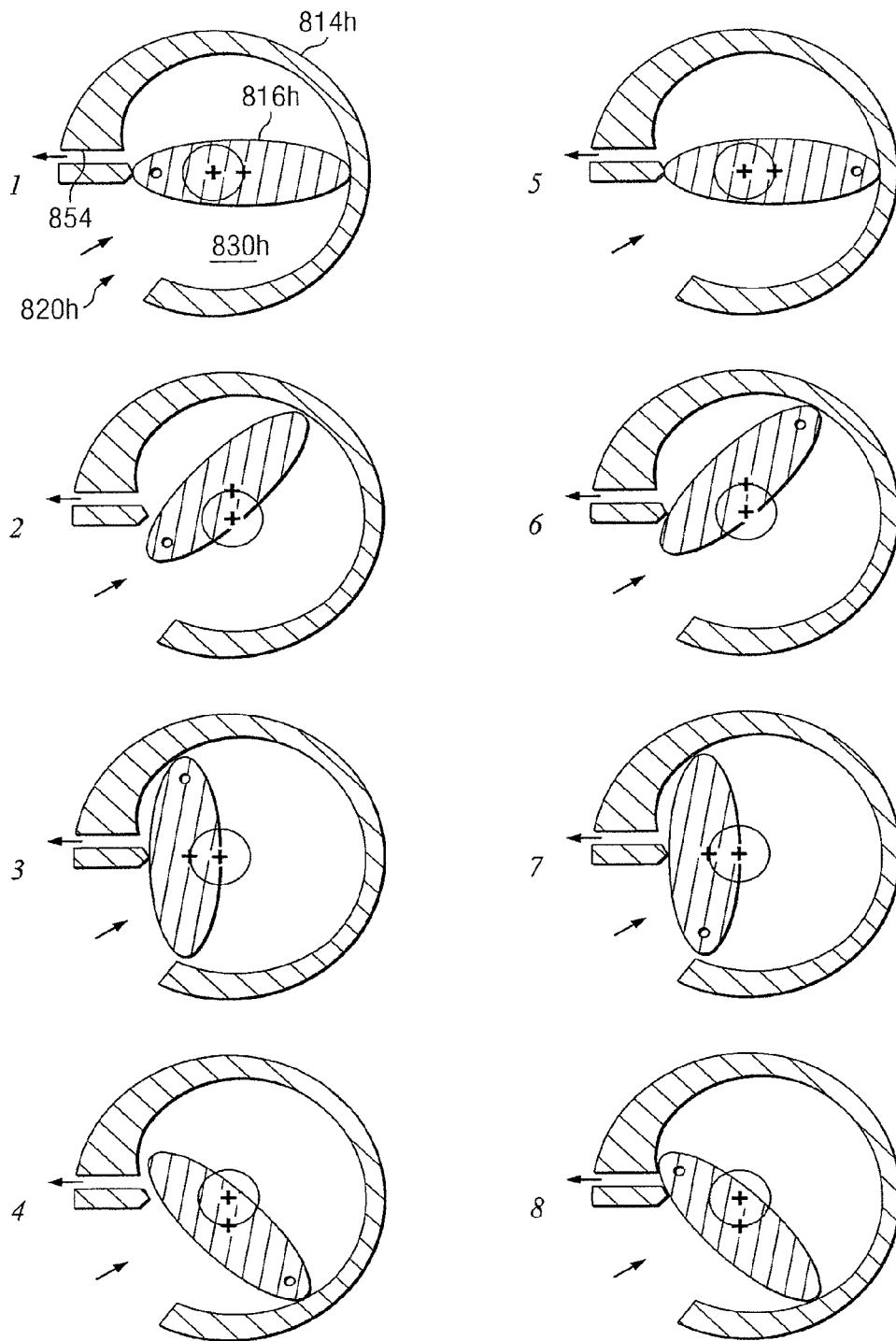

FIG. 65

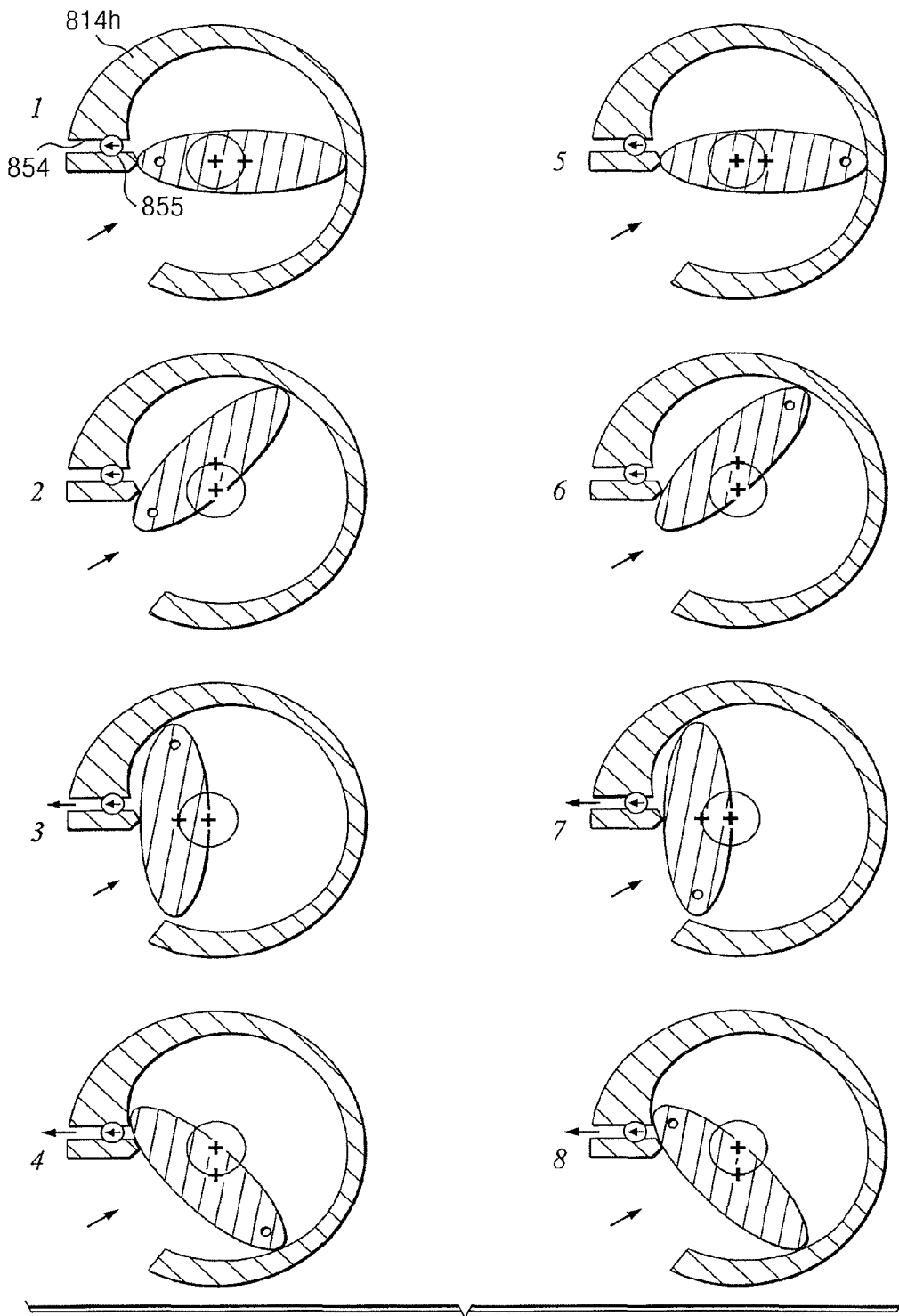
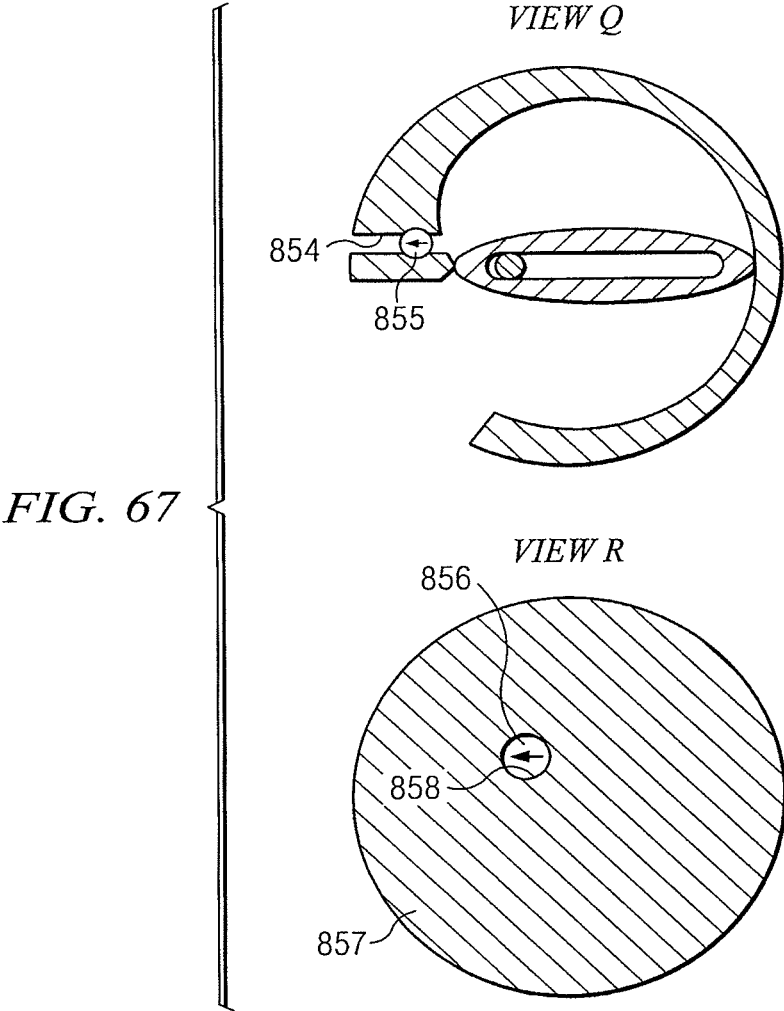

FIG. 66



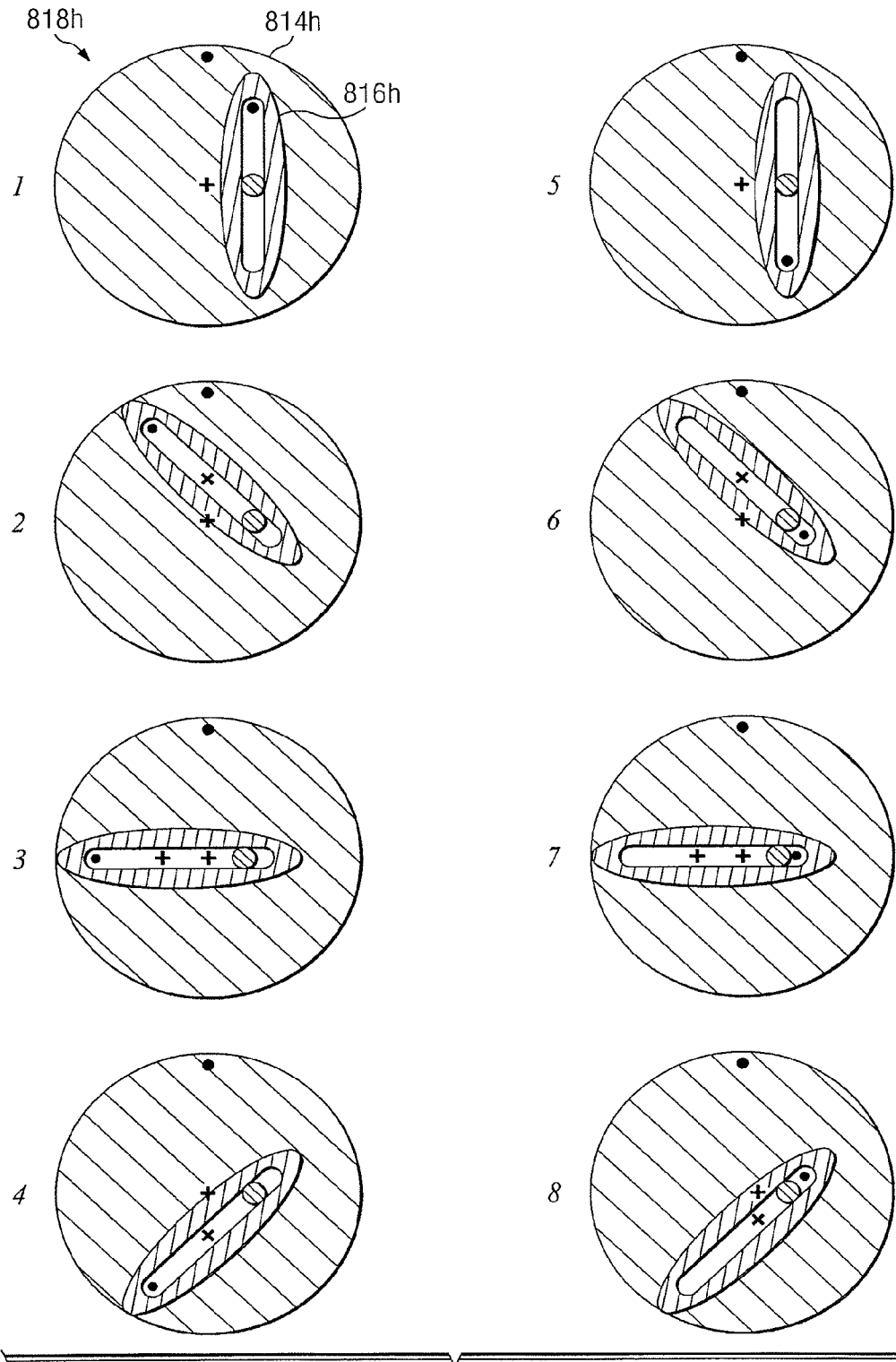

FIG. 68

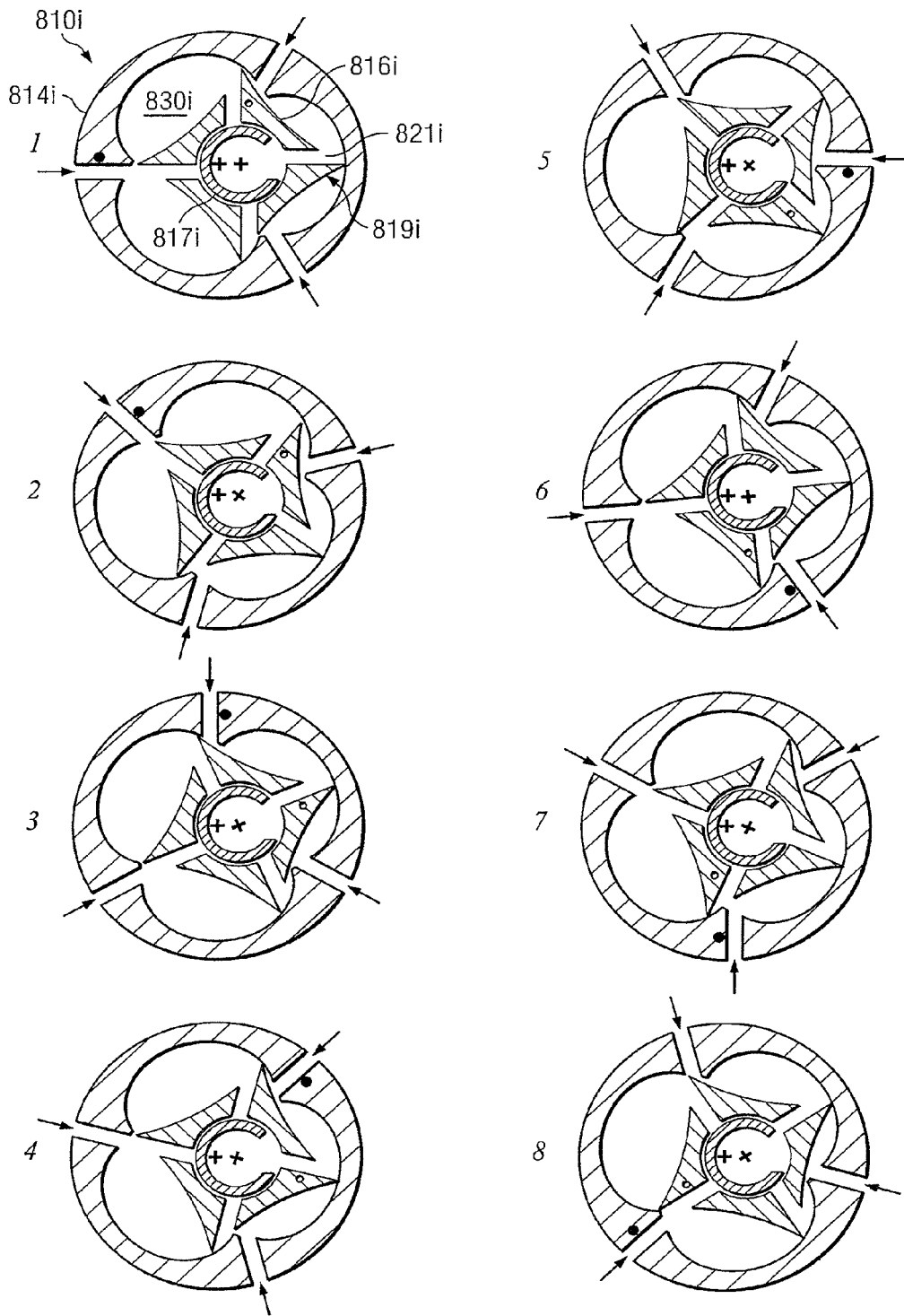

FIG. 69

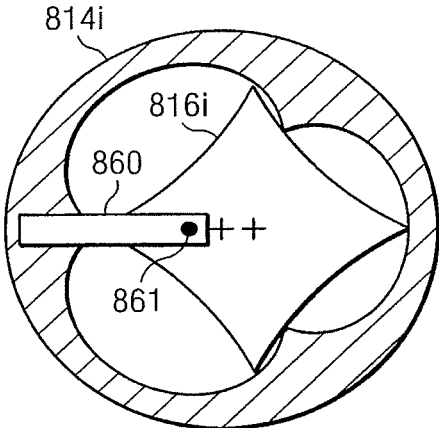

FIG. 70

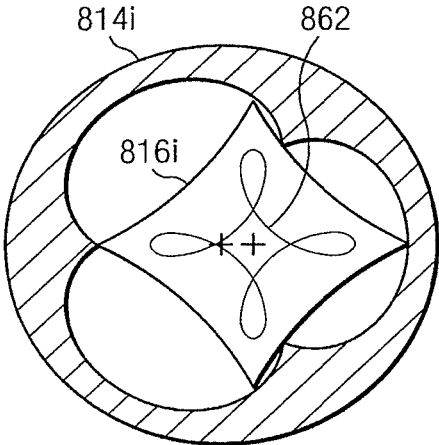
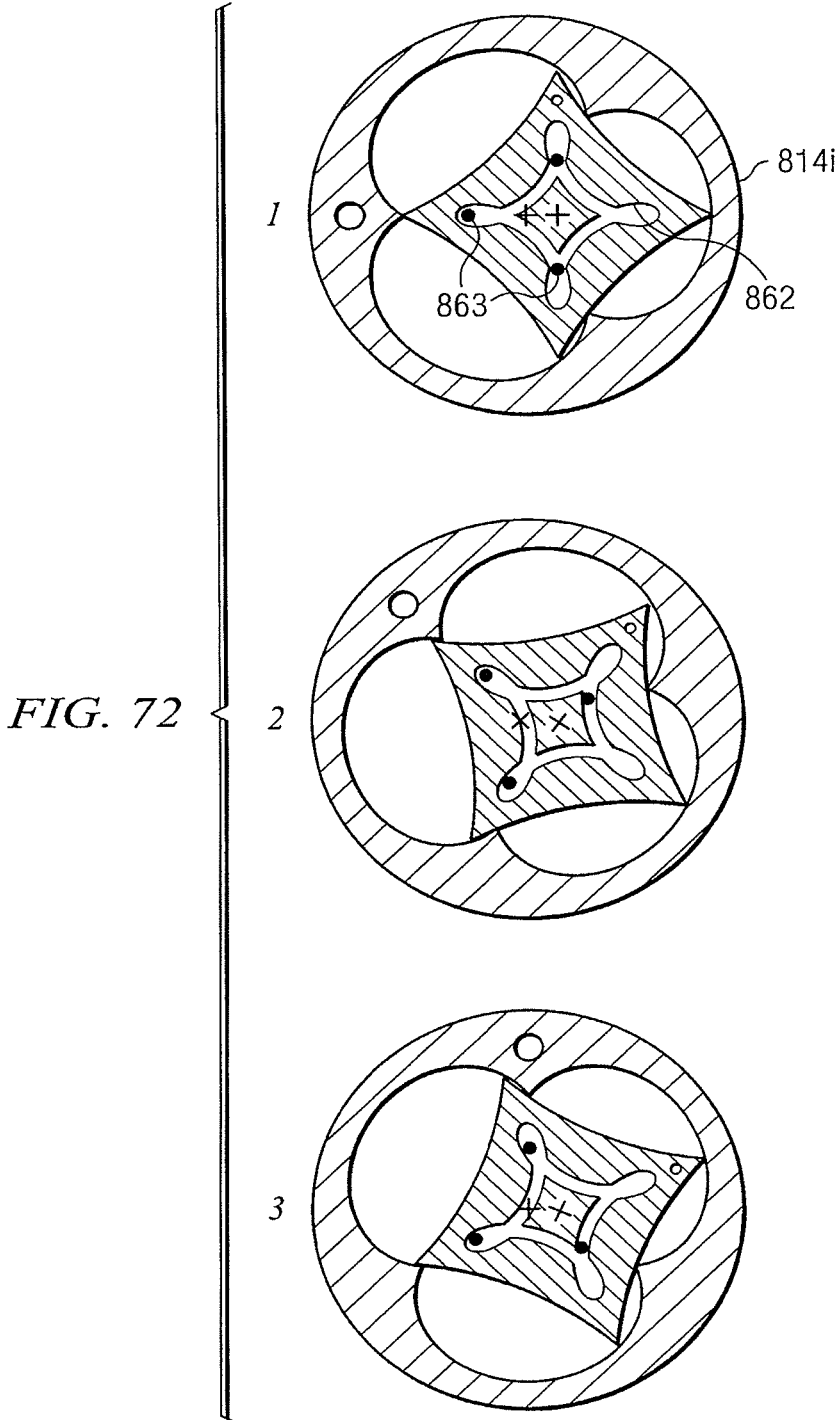

FIG. 71



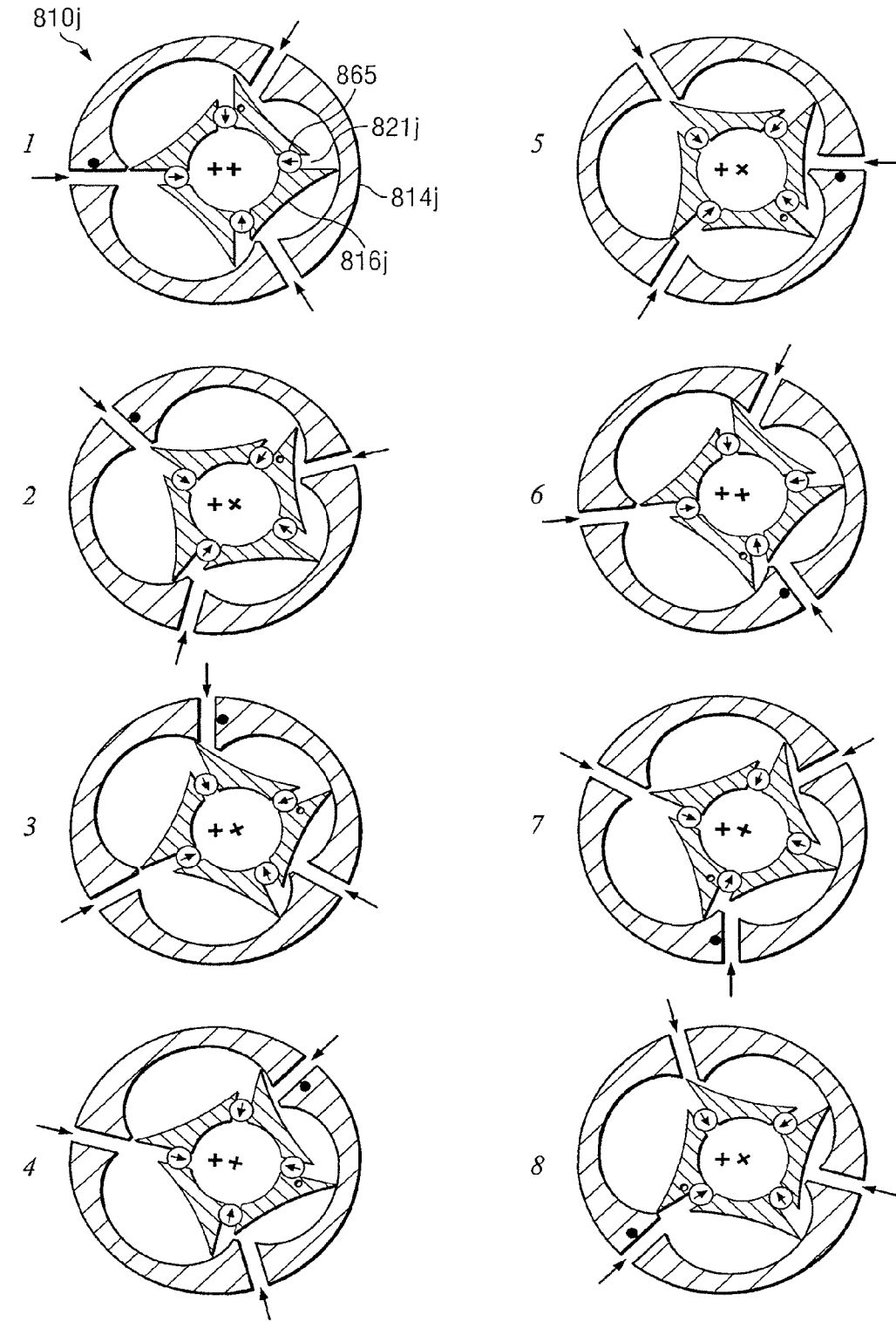

FIG. 73

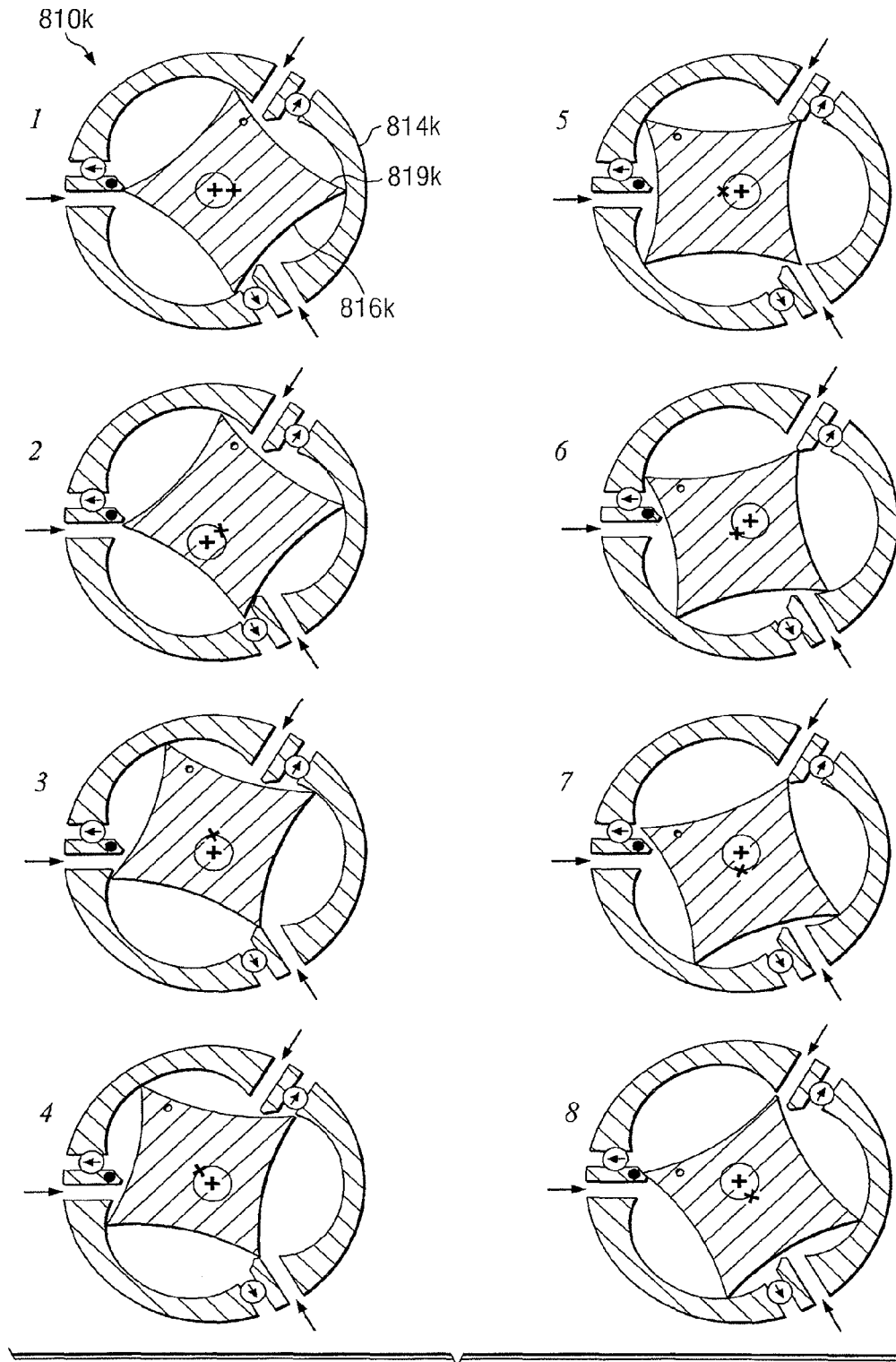

FIG. 74

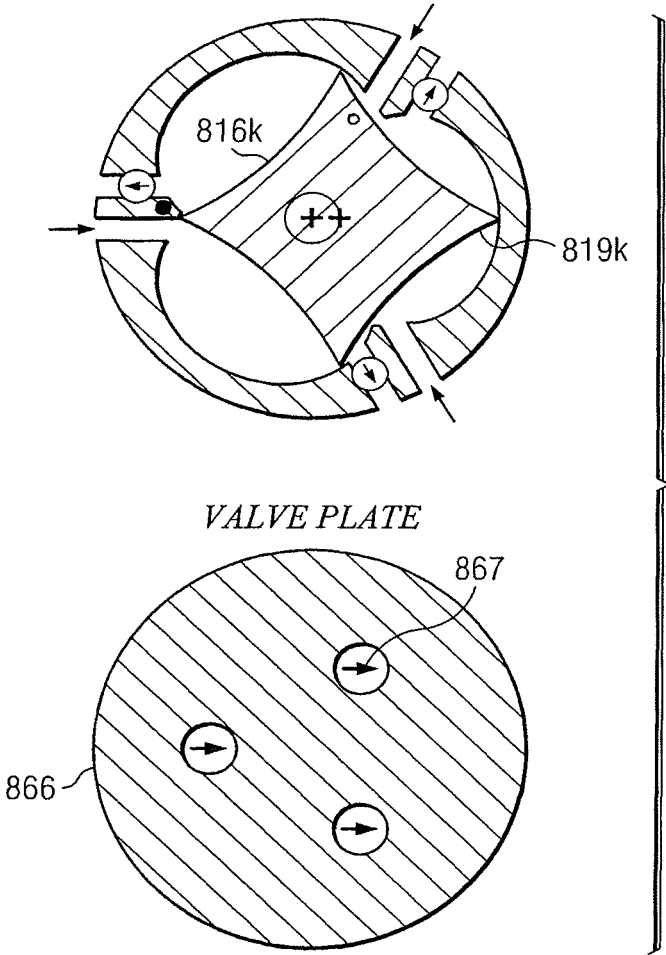

FIG. 75

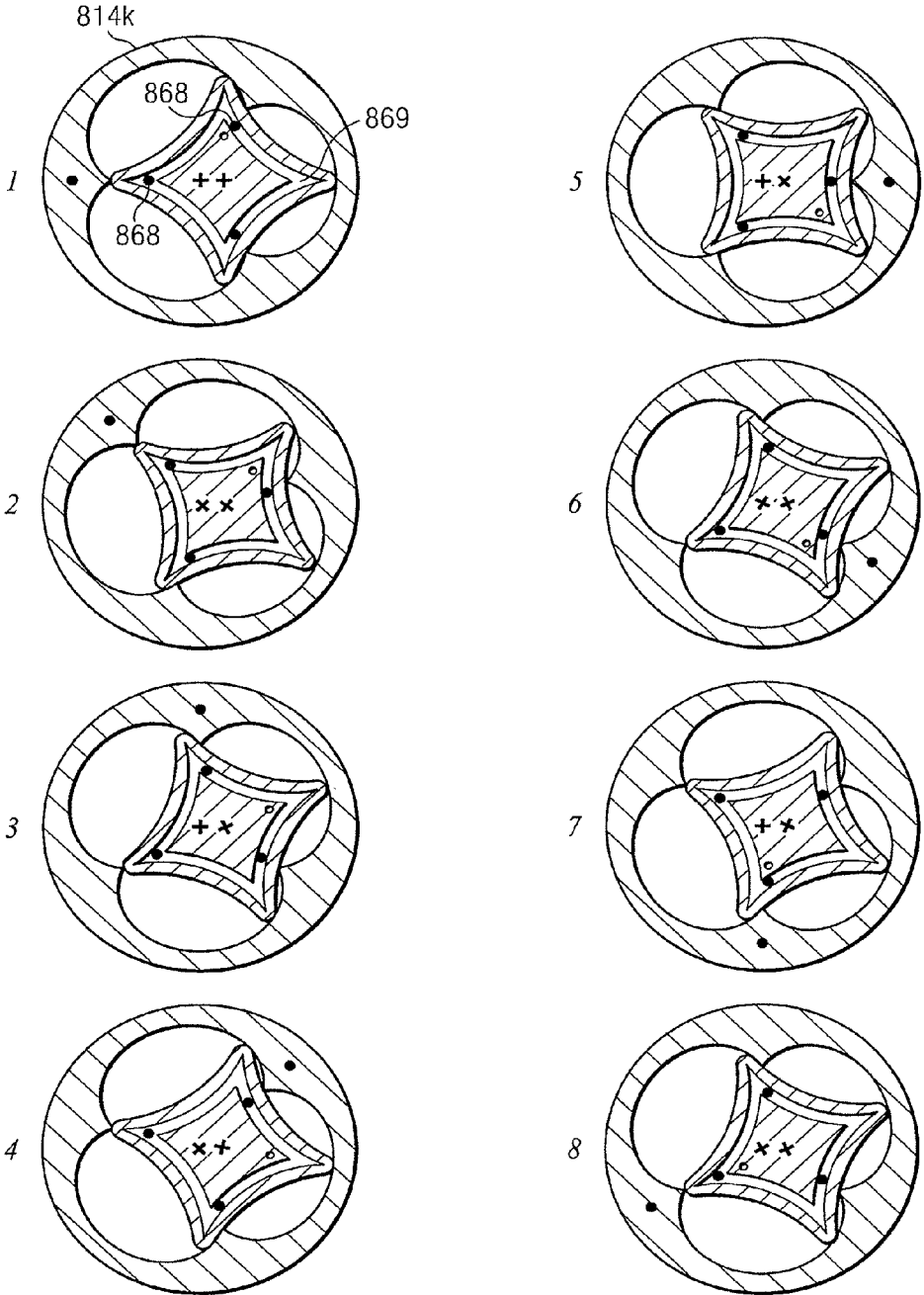

FIG. 76

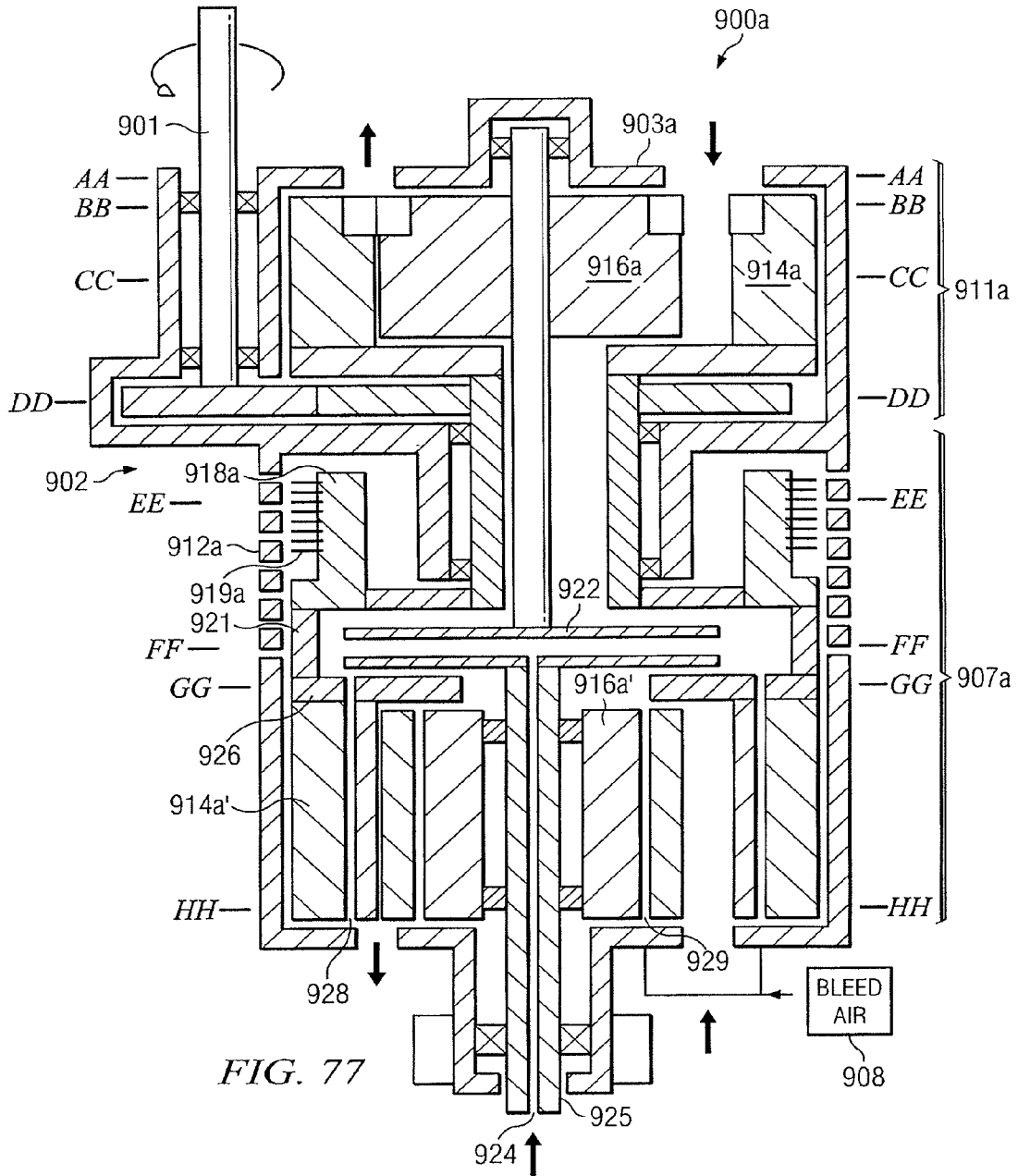
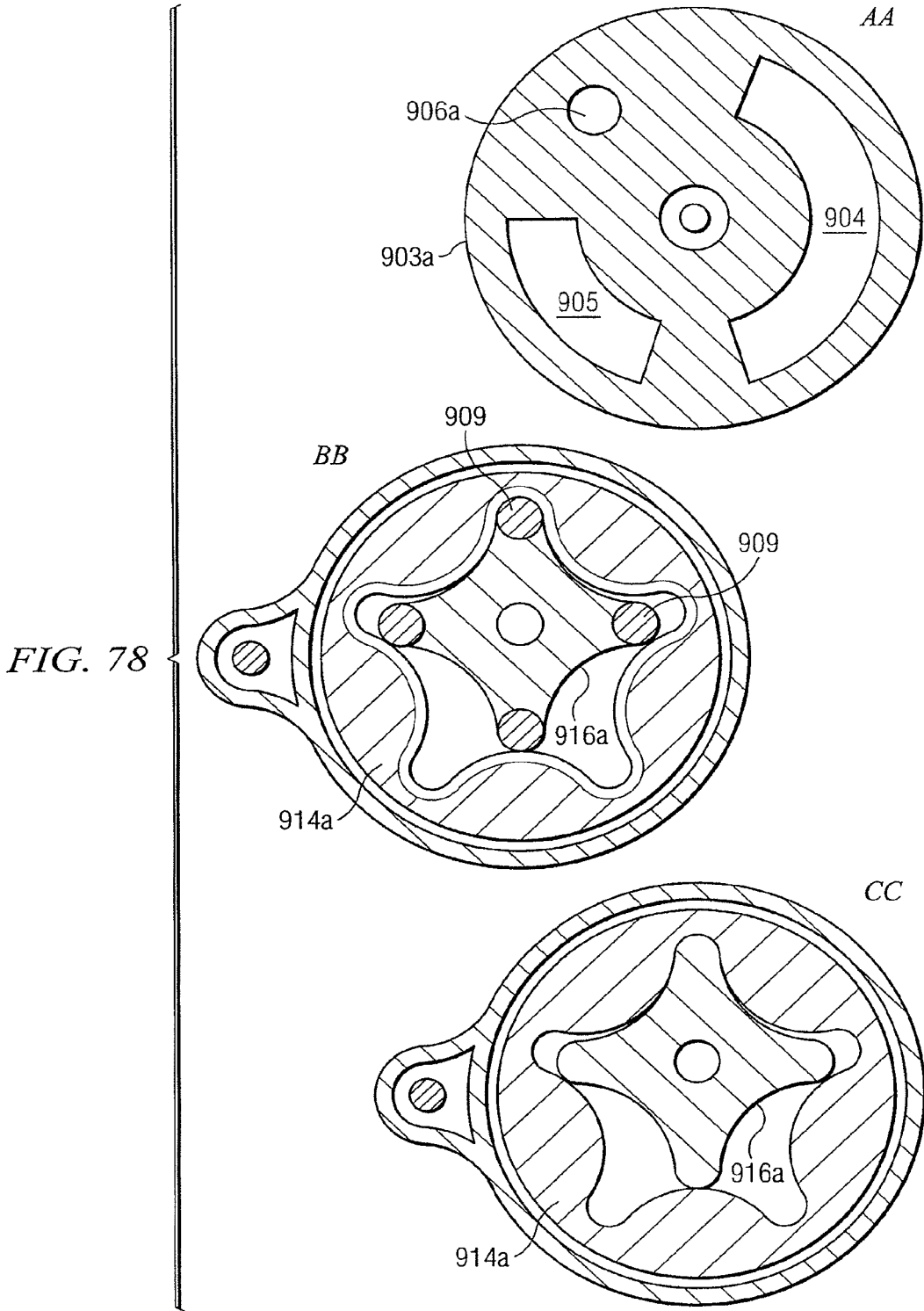
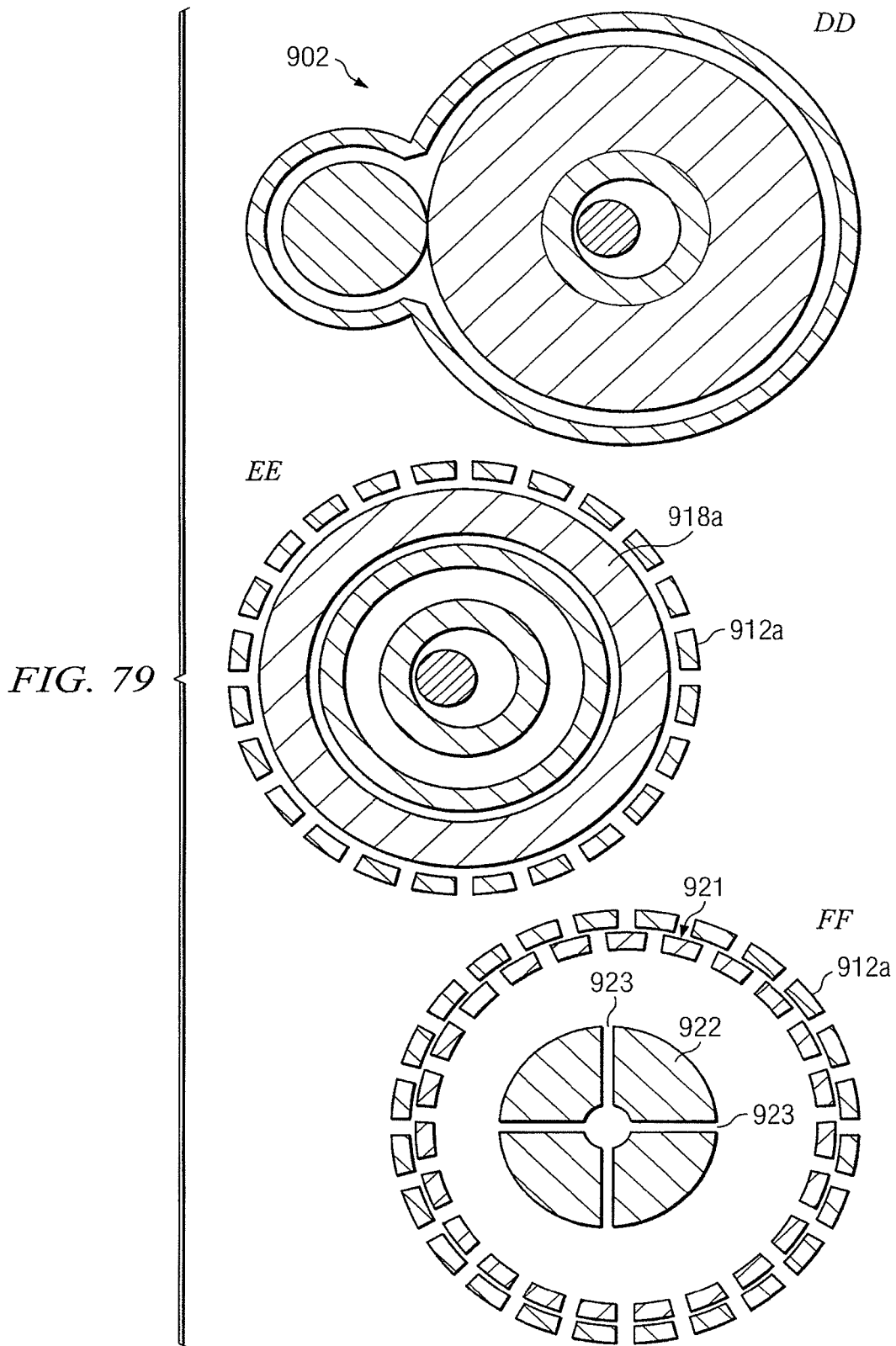
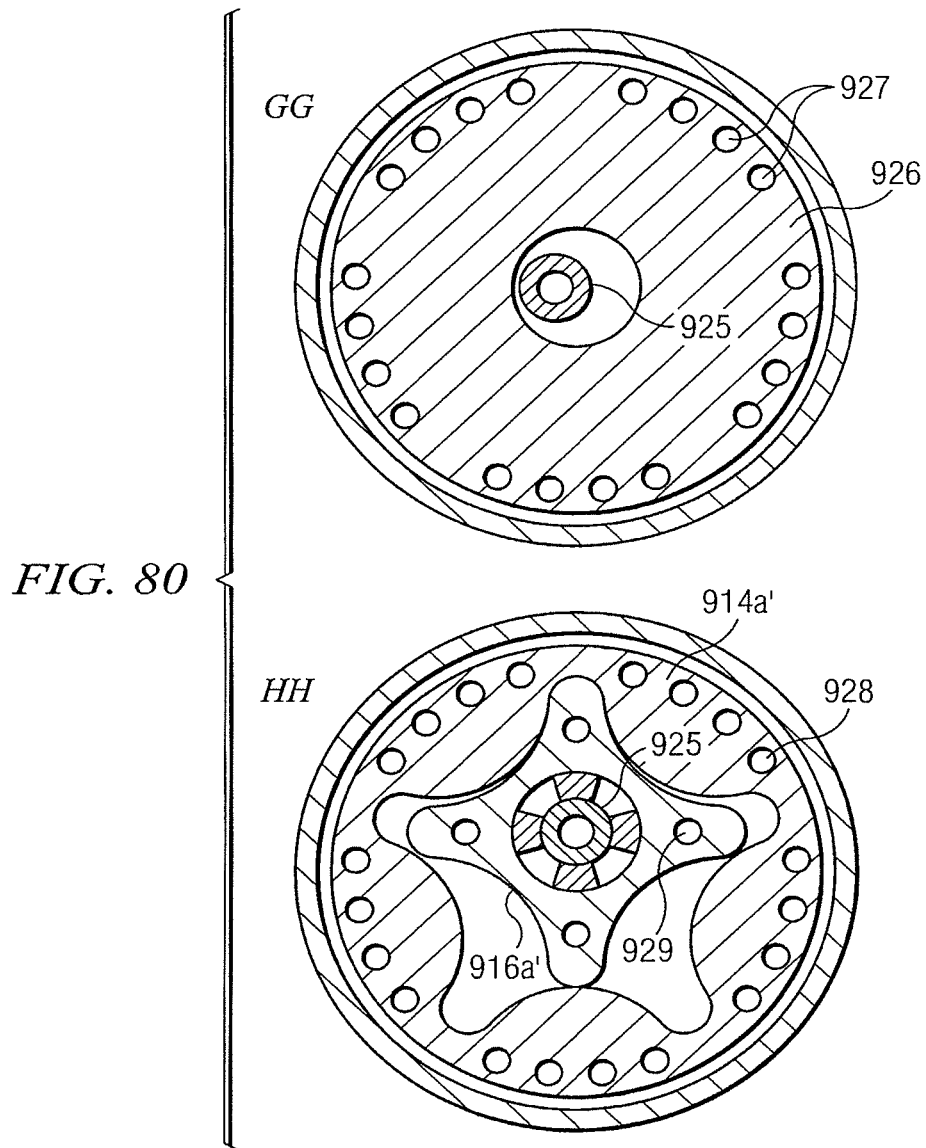
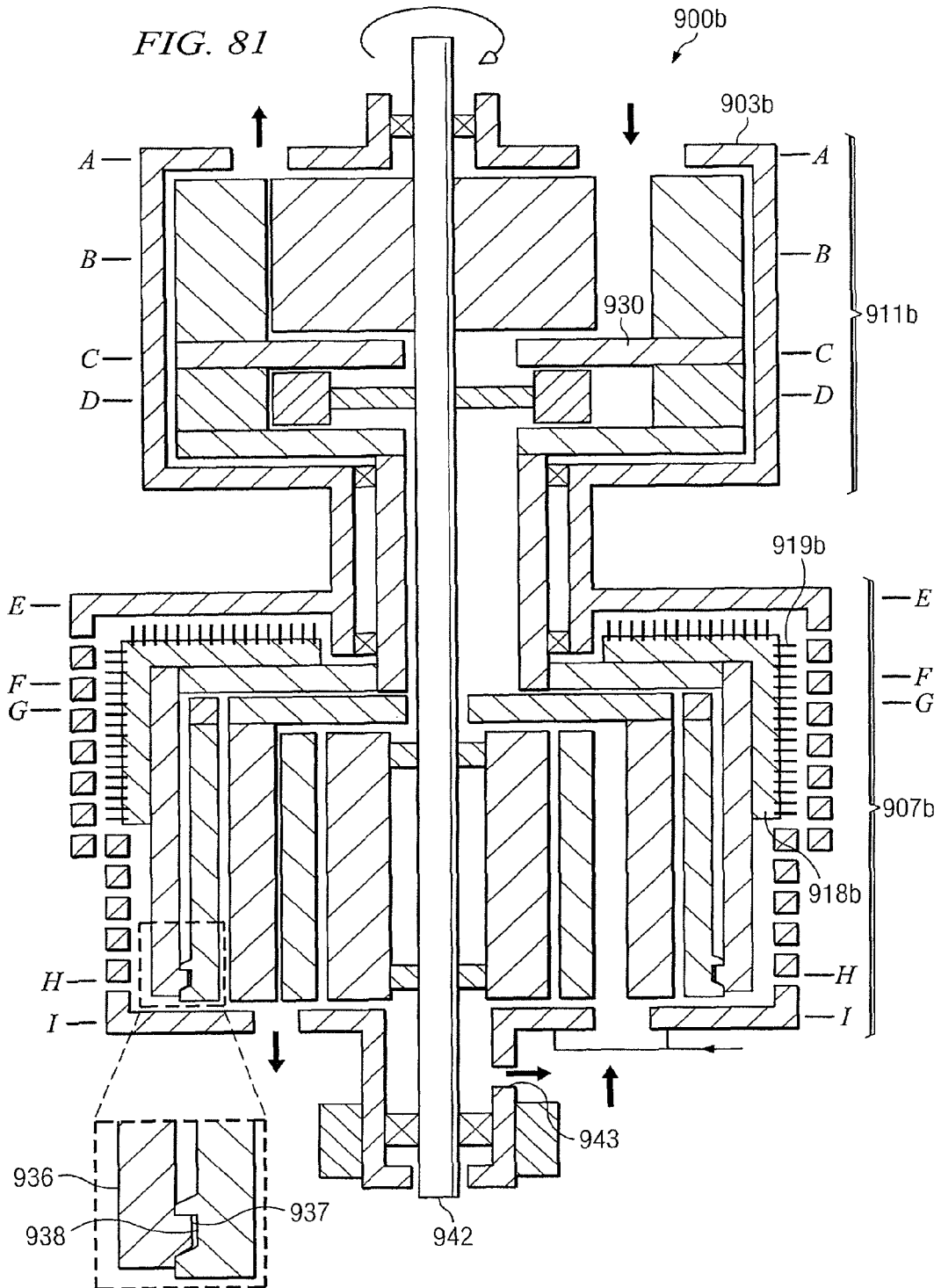

FIG. 77









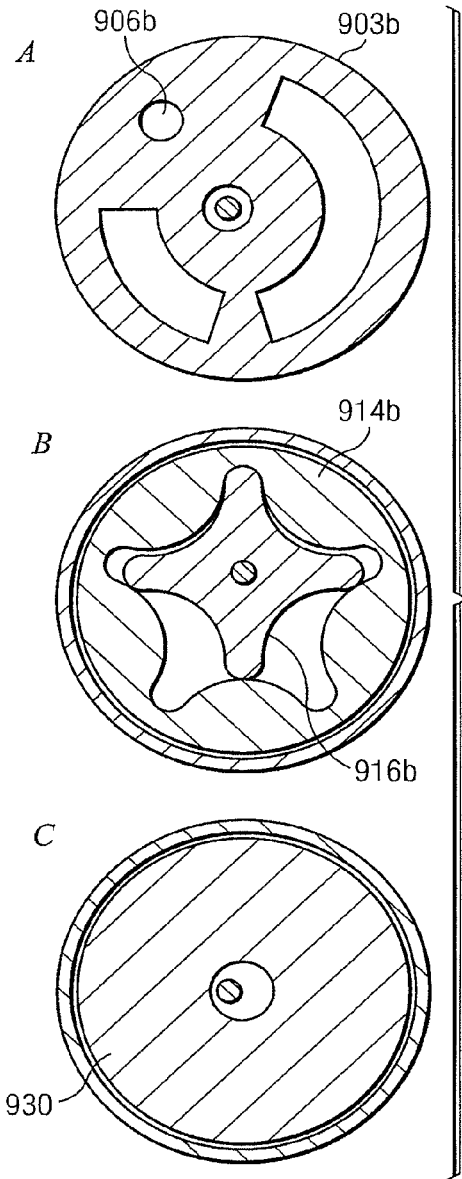

FIG. 82

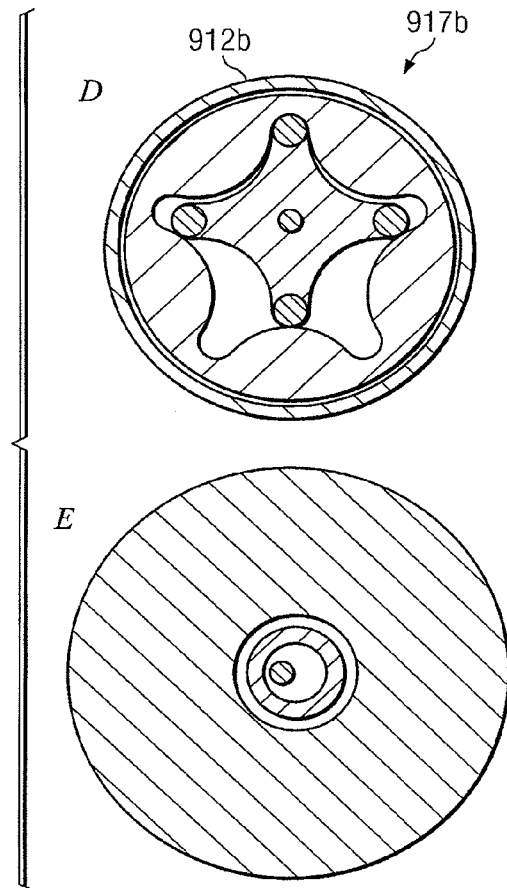
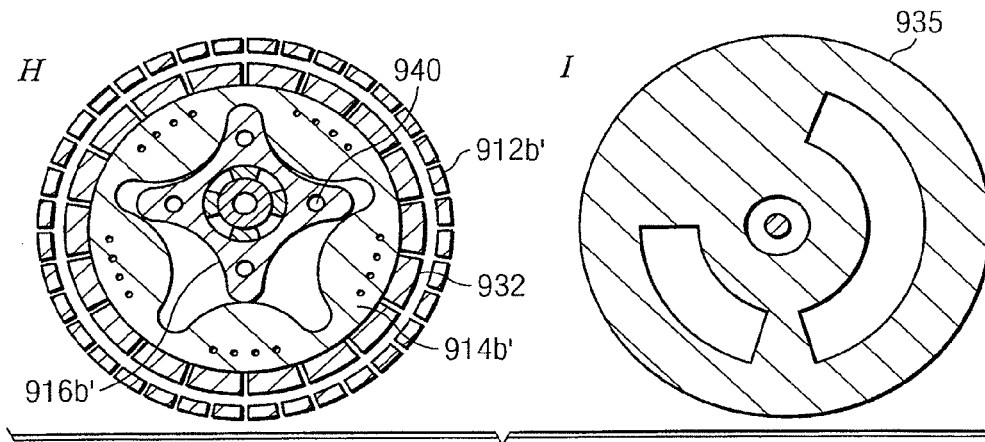
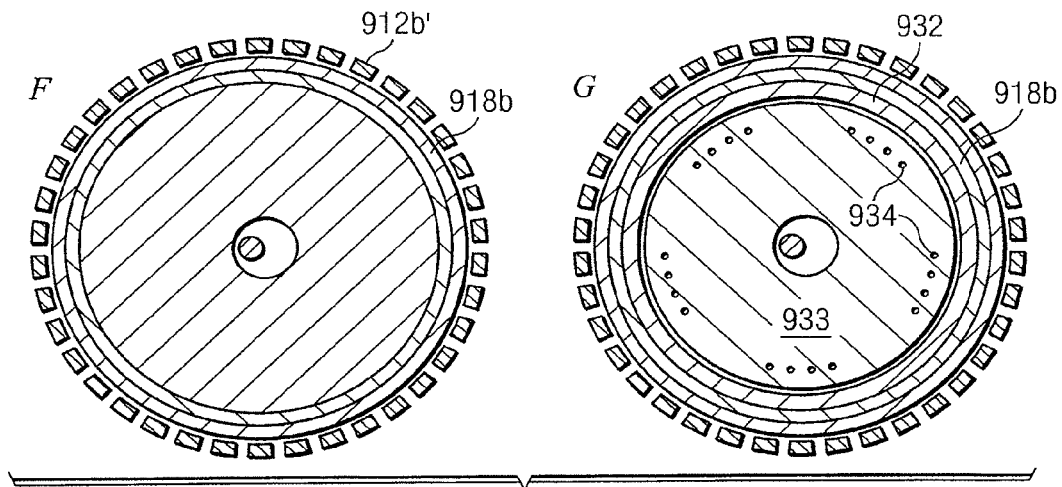

FIG. 83



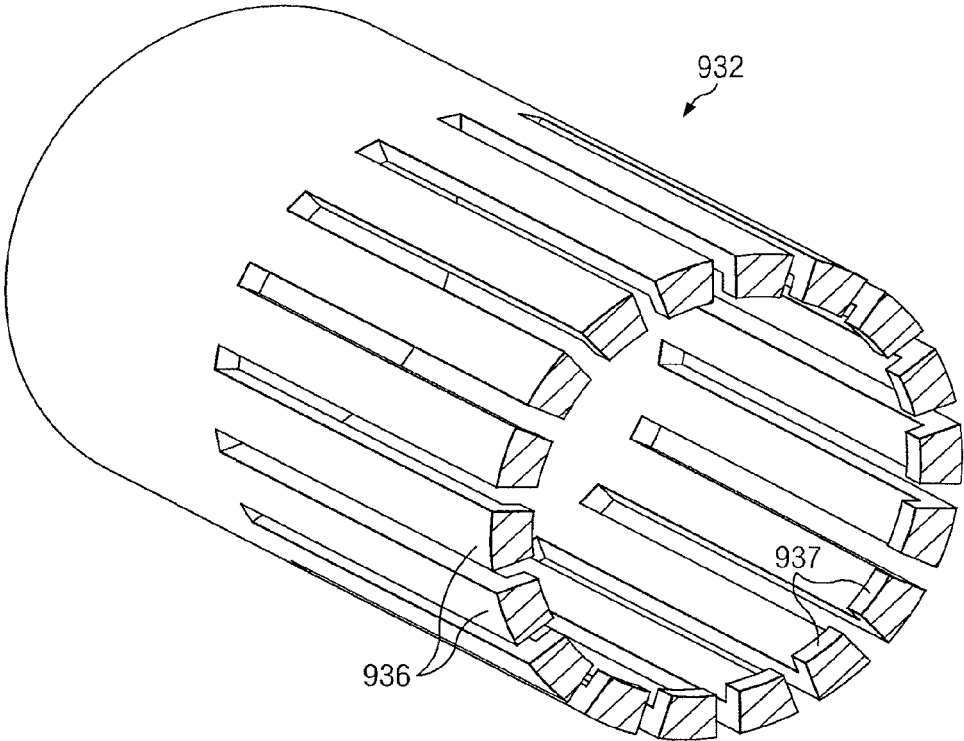

FIG. 86

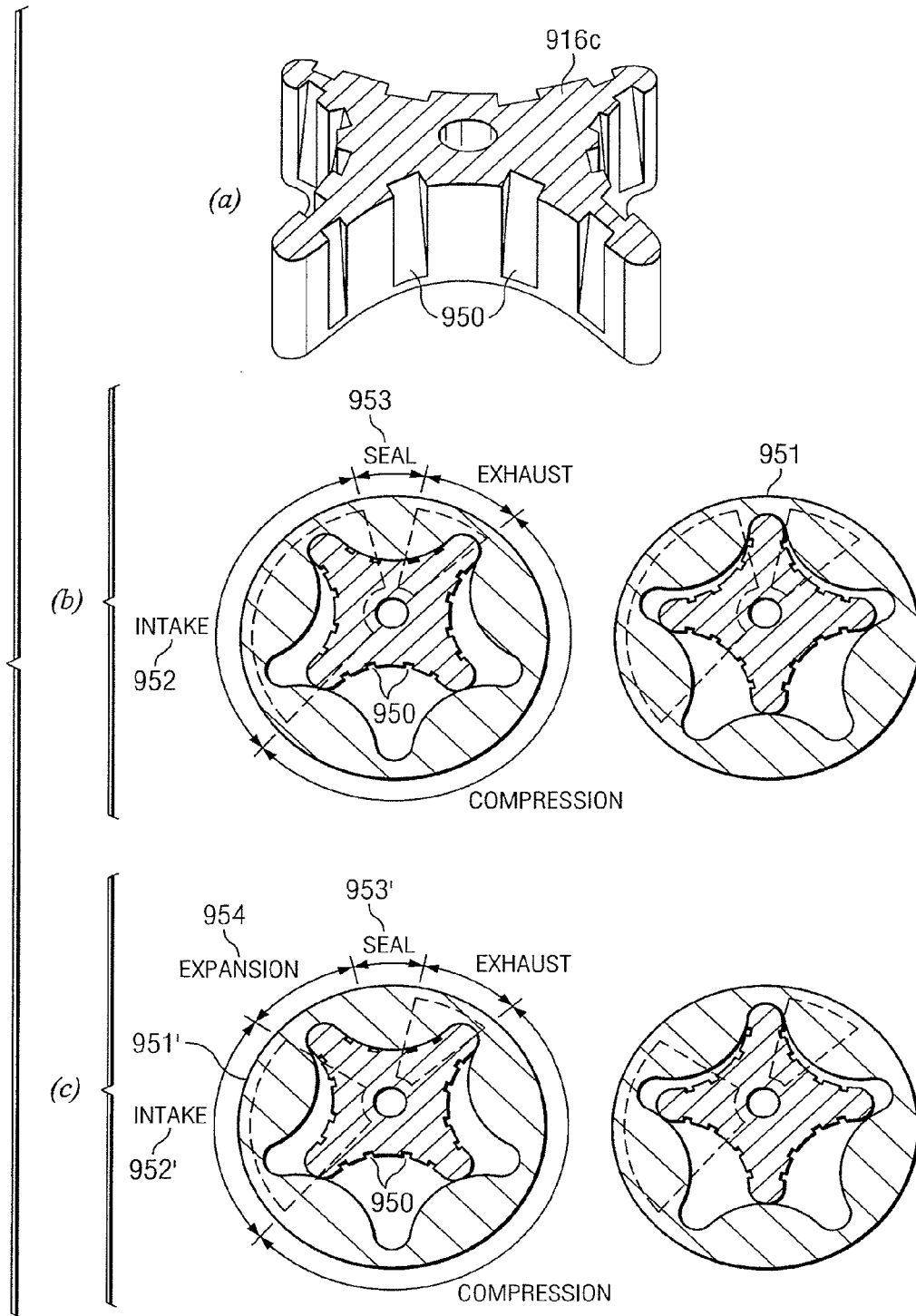
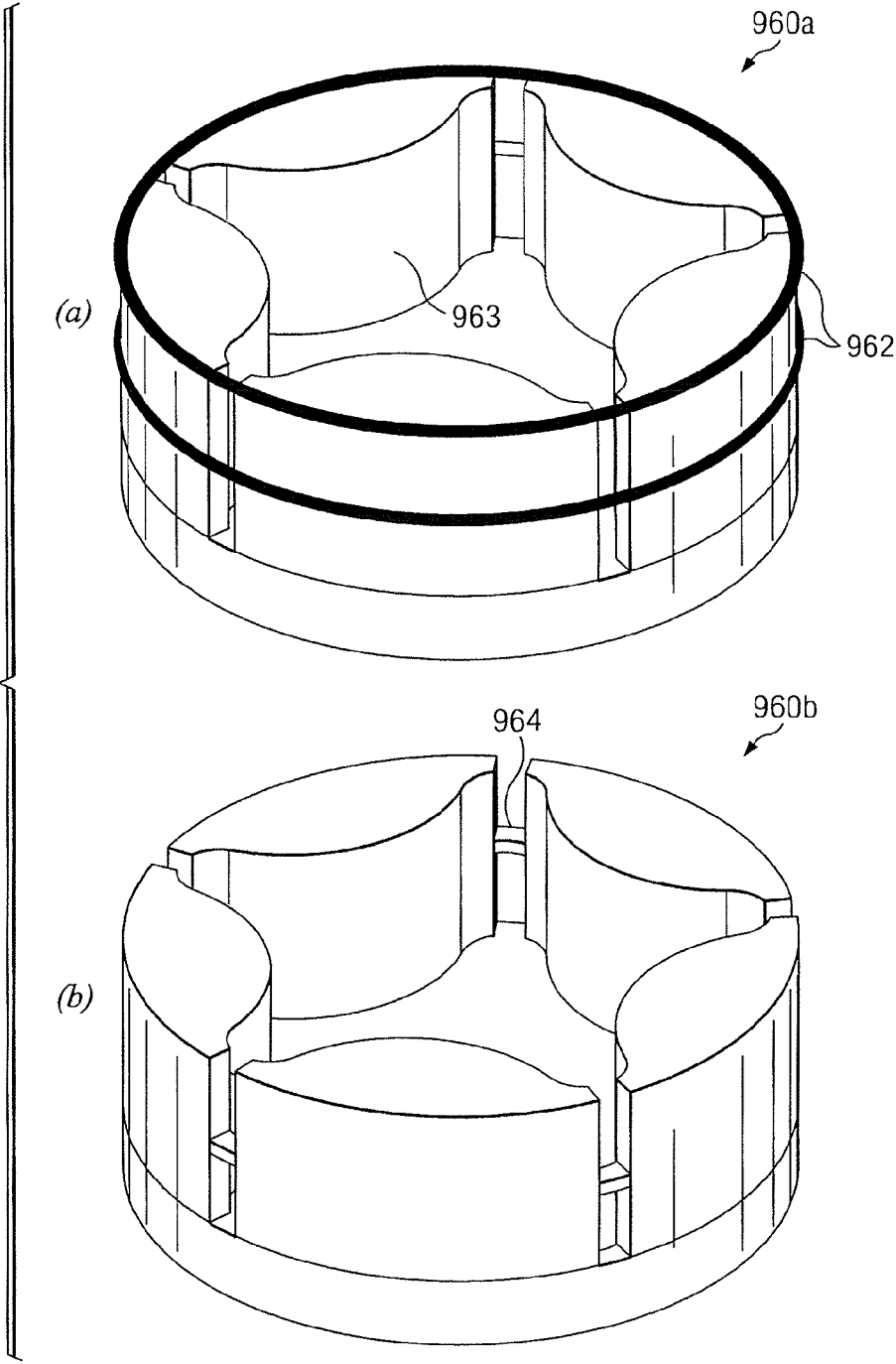
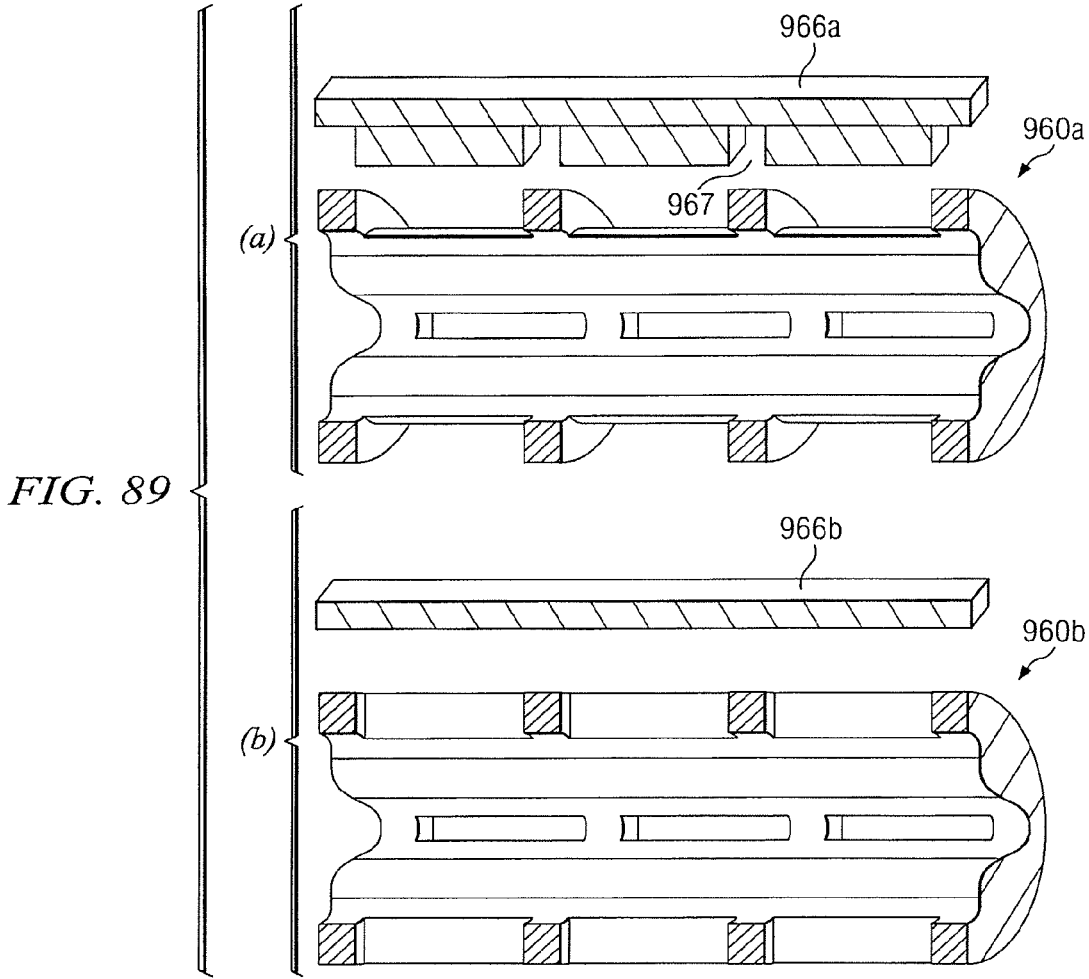
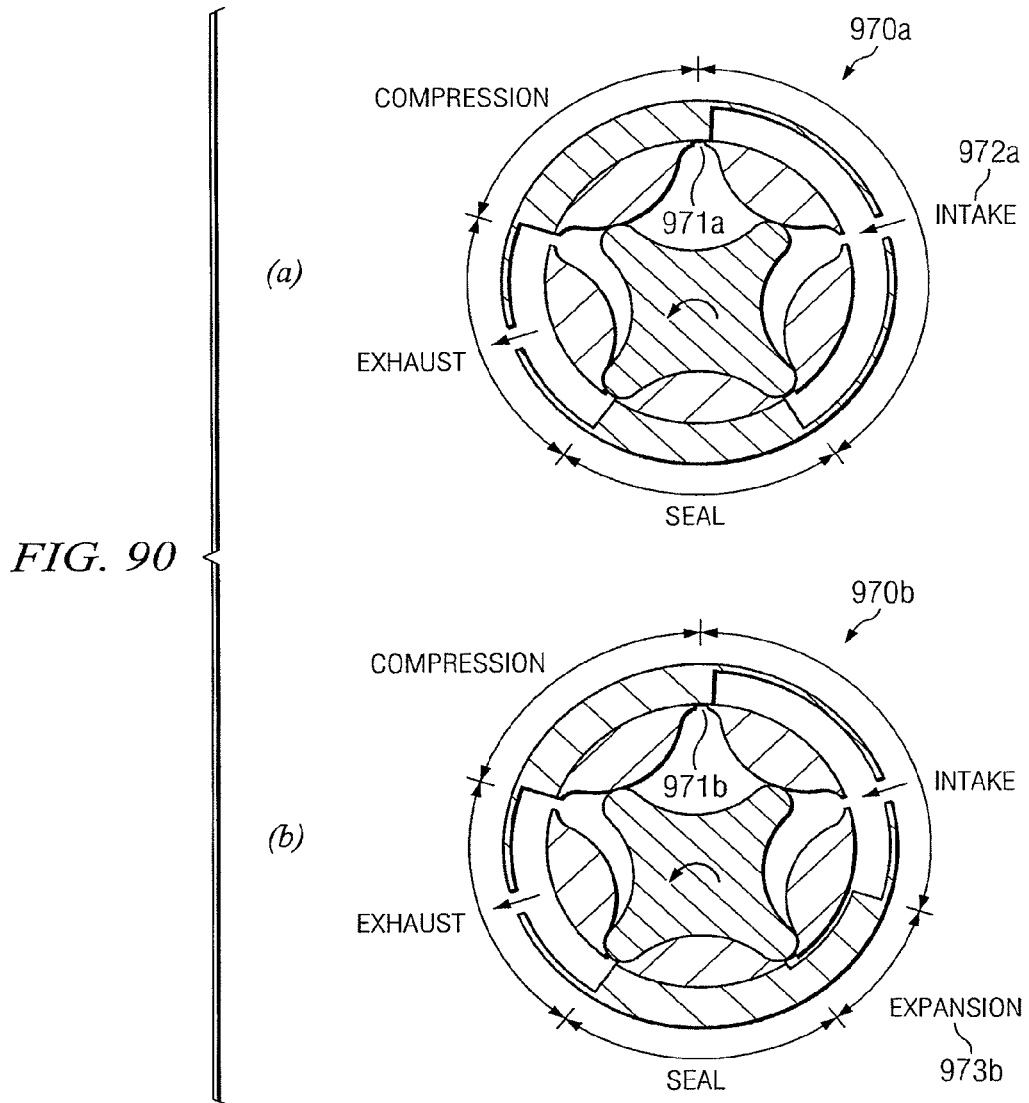

FIG. 87

FIG. 88







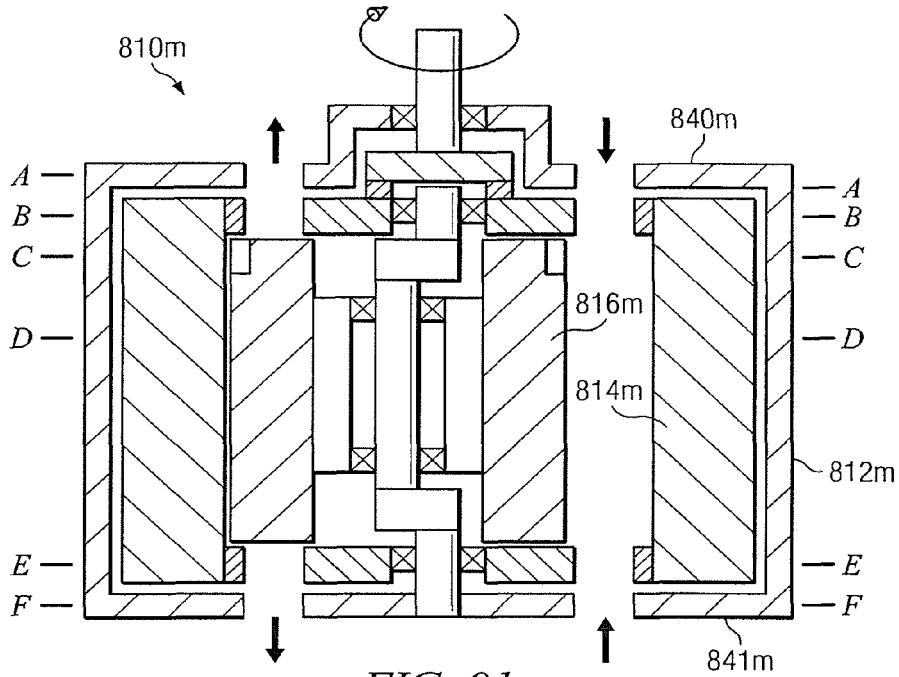

FIG. 91

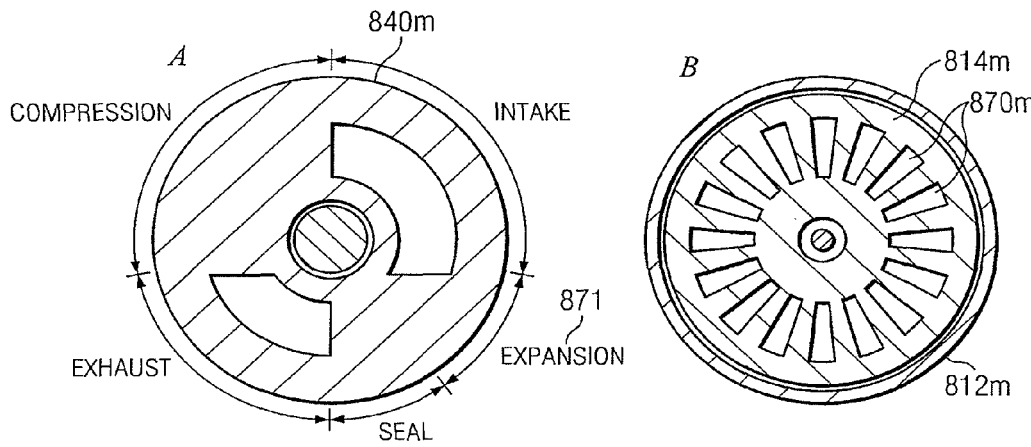
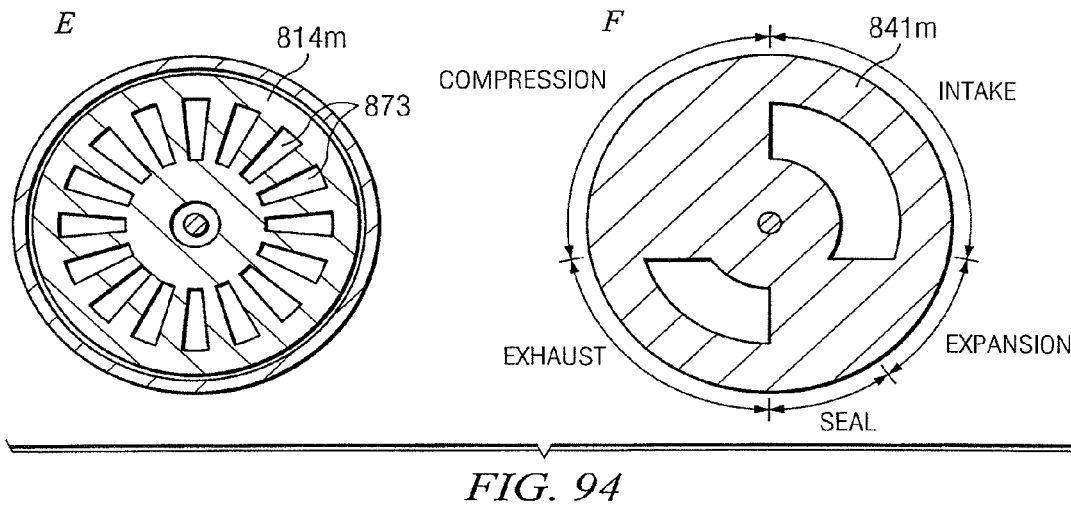
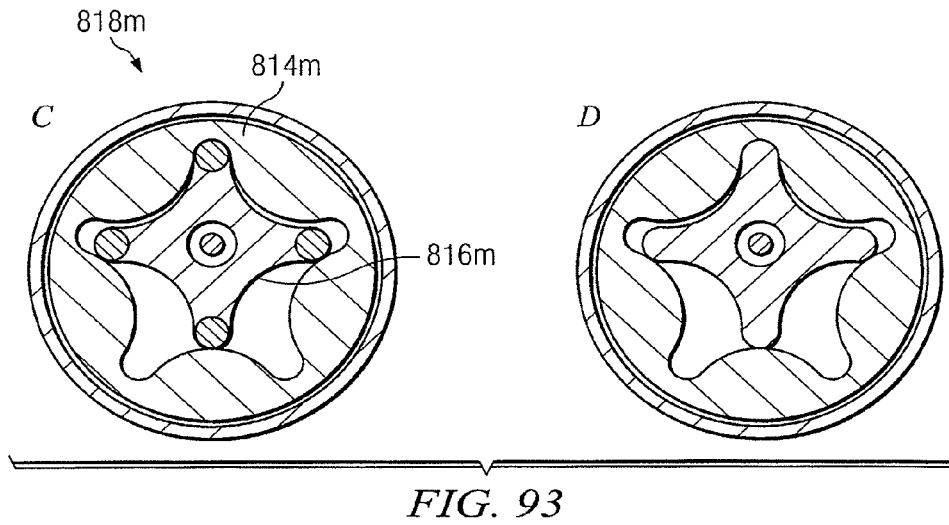

FIG. 92



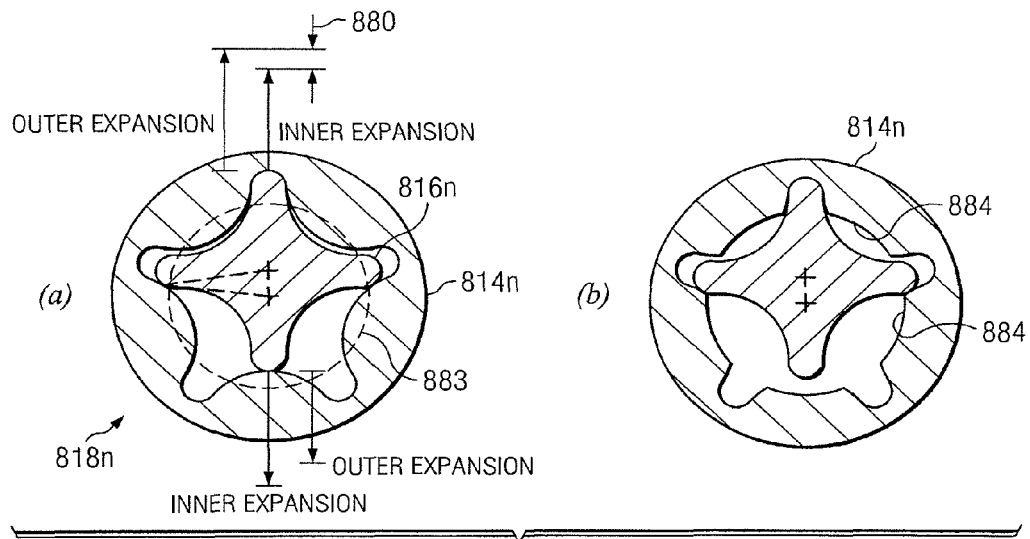

FIG. 95

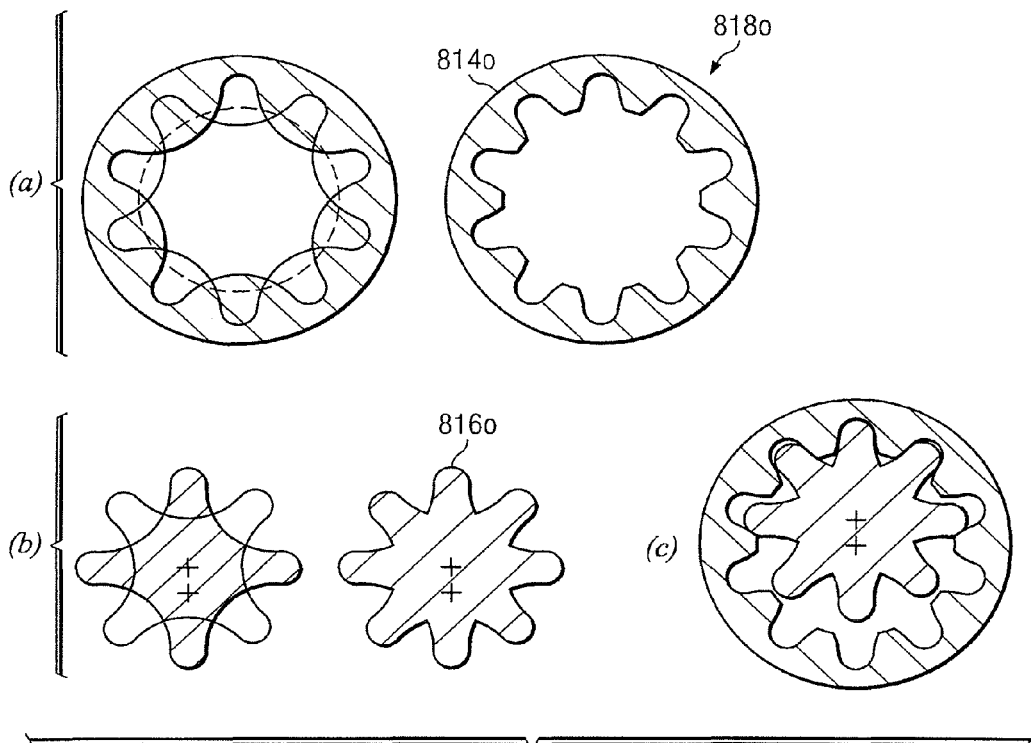

FIG. 96

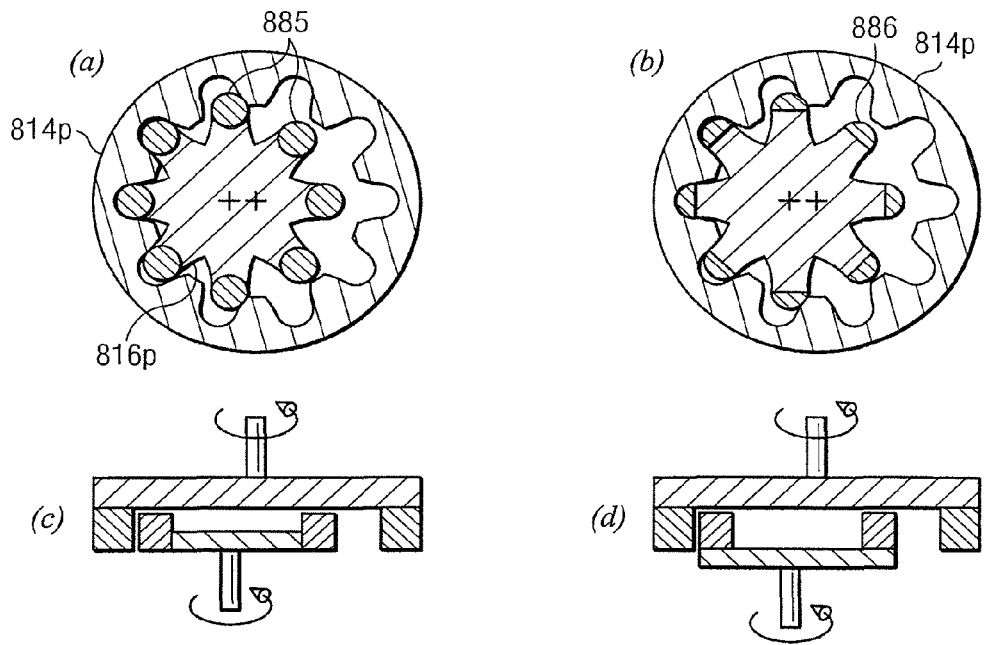

FIG. 97

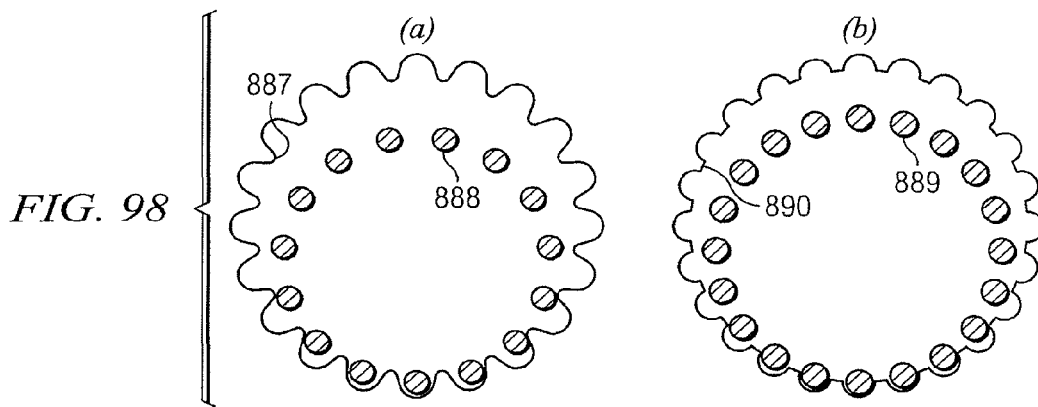
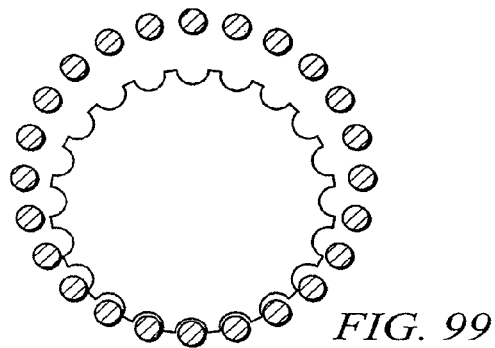

FIG. 98



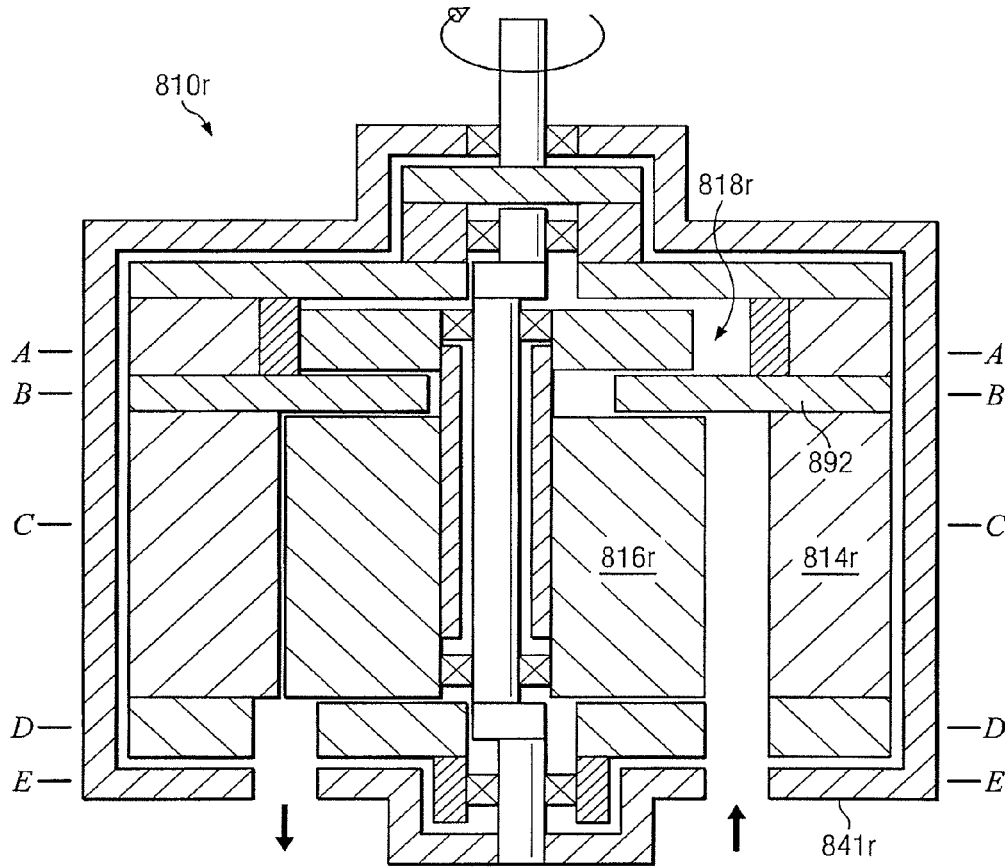

FIG. 100

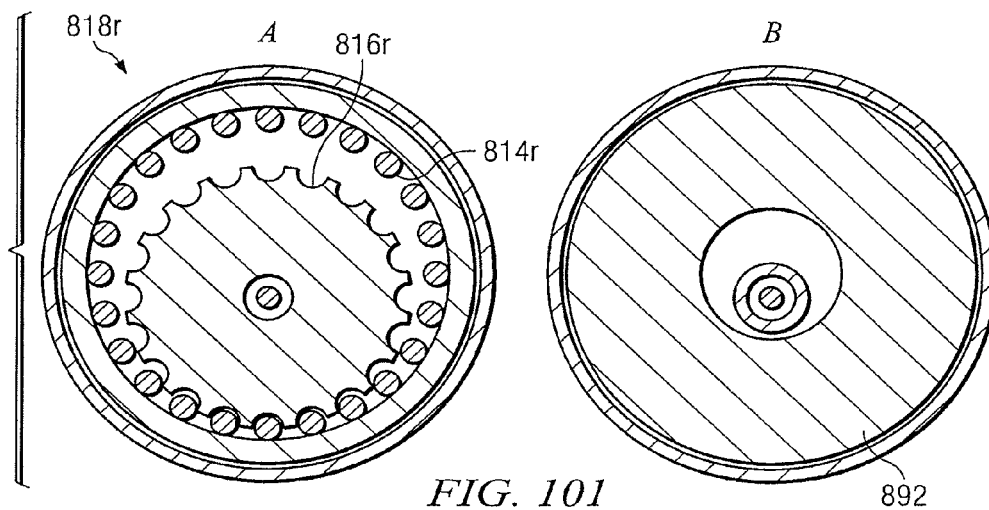

FIG. 101

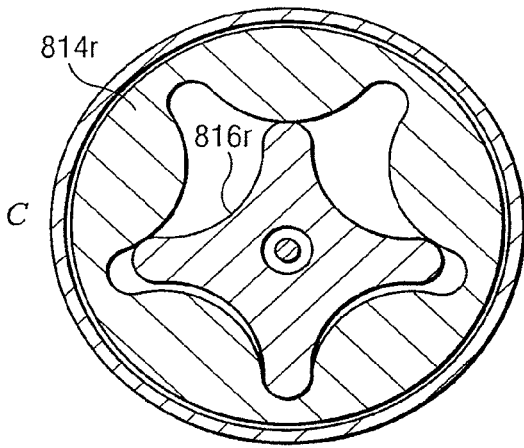

FIG. 102

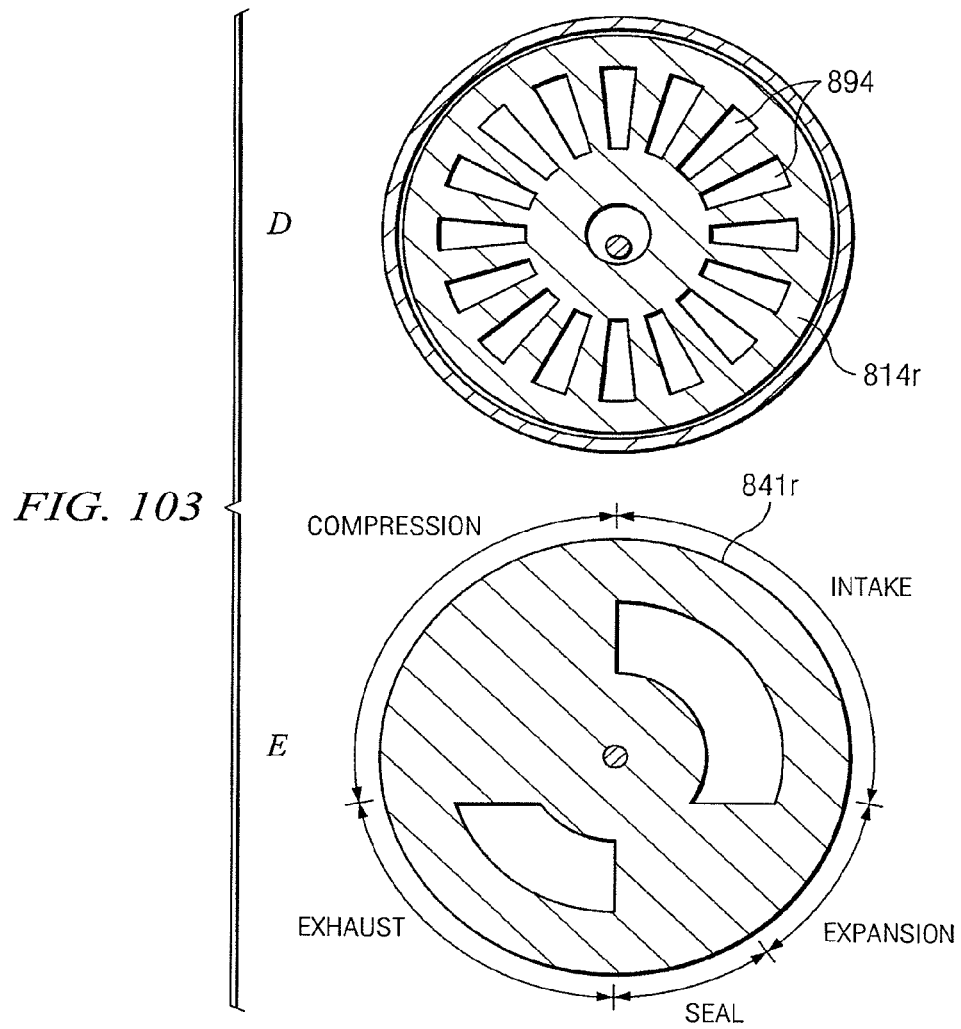

FIG. 103

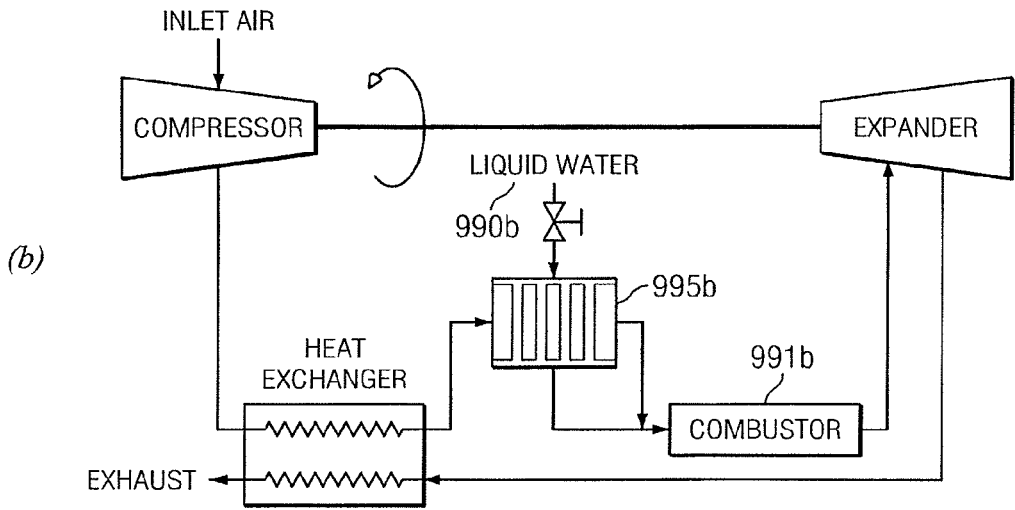
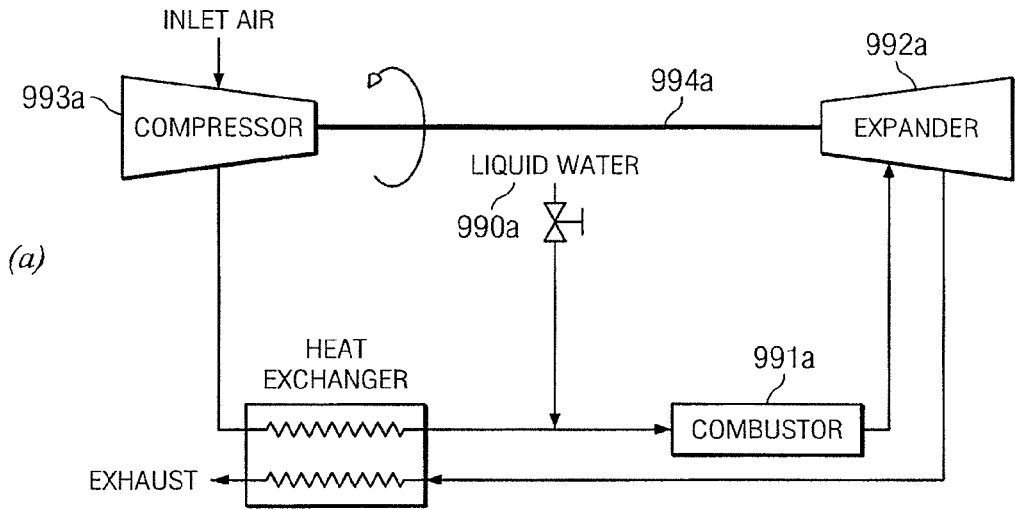

FIG. 104

1

SEALING SYSTEM FOR GEROTOR APPARATUS

RELATED APPLICATIONS

This application is a continuation of U.S. patent application Ser. No. 11/041,011, filed Jan. 21, 2005, now abandoned entitled "GEROTOR APPARATUS FOR A QUASI-ISOTHERMAL BRAYTON CYCLE ENGINE," which claims priority from U.S. Provisional Application Ser. No. 60/538,747, entitled "QUASI-ISOTHERMAL BRAYTON CYCLE ENGINE," filed Jan. 23, 2004.

TECHNICAL FIELD OF THE INVENTION

The present invention relates to a gerotor apparatus that functions as a compressor or expander. The gerotor apparatus may be applied generally to Brayton cycle engines and, more particularly, to a quasi-isothermal Brayton cycle engine.

BACKGROUND OF THE INVENTION

For mobile applications, such as an automobile or truck, it is generally desirable to use a heat engine that has the following characteristics: internal combustion to reduce the need for heat exchangers; complete expansion for improved efficiency; isothermal compression and expansion; high power density; high-temperature expansion for high efficiency; ability to efficiently "throttle" the engine for part-load conditions; high turn-down ratio (i.e., the ability to operate at widely ranging speeds and torques); low pollution; uses standard components with which the automotive industry is familiar; multifuel capability; and regenerative braking.

There are currently several types of heat engines, each with their own characteristics and cycles. These heat engines include the Otto Cycle engine, the Diesel Cycle engine, the Rankine Cycle engine, the Stirling Cycle engine, the Erickson Cycle engine, the Carnot Cycle engine, and the Brayton Cycle engine. A brief description of each engine is provided below.

The Otto Cycle engine is an inexpensive, internal combustion, low-compression engine with a fairly low efficiency. This engine is widely used to power automobiles.

The Diesel Cycle engine is a moderately expensive, internal combustion, high-compression engine with a high efficiency that is widely used to power trucks and trains.

The Rankine Cycle engine is an external combustion engine that is generally used in electric power plants. Water is the most common working fluid.

The Erickson Cycle engine uses isothermal compression and expansion with constant-pressure heat transfer. It may be implemented as either an external or internal combustion cycle. In practice, a perfect Erickson cycle is difficult to achieve because isothermal expansion and compression are not readily attained in large, industrial equipment.

The Carnot Cycle engine uses isothermal compression and expansion and adiabatic compression and expansion. The Carnot Cycle may be implemented as either an external or internal combustion cycle. It features low power density, mechanical complexity, and difficult-to-achieve constant-temperature compressor and expander.

The Stirling Cycle engine uses isothermal compression and expansion with constant-volume heat transfer. It is almost always implemented as an external combustion cycle. It has a higher power density than the Carnot cycle, but it is difficult to perform the heat exchange, and it is difficult to achieve constant-temperature compression and expansion.

2

The Stirling, Erickson, and Carnot cycles are as efficient as nature allows because heat is delivered at a uniformly high temperature, T_{hot} during the isothermal expansion, and rejected at a uniformly low temperature, T_{cold} , during the isothermal compression. The maximum efficiency, D_{max} , of these three cycles is:

$$\eta_{max} = 1 - \frac{T_{cold}}{T_{hot}}$$

This efficiency is attainable only if the engine is "reversible," meaning that the engine is frictionless, and that there are no temperature or pressure gradients. In practice, real engines have "irreversibilities," or losses, associated with friction and temperature/pressure gradients.

The Brayton Cycle engine is an internal combustion engine that is generally implemented with turbines and is generally used to power aircraft and some electric power plants. The Brayton cycle features very high power density, normally does not use a heat exchanger, and has a lower efficiency than the other cycles. When a regenerator is added to the Brayton cycle, however, the cycle efficiency increases. Traditionally, the Brayton cycle is implemented using axial-flow, multi-stage compressors and expanders. These devices are generally suitable for aviation in which aircraft operate at fairly constant speeds; they are generally not suitable for most transportation applications, such as automobiles, buses, trucks, and trains, which must operate over widely varying speeds.

The Otto cycle, the Diesel cycle, the Brayton cycle, and the Rankine cycle all have efficiencies less than the maximum because they do not use isothermal compression and expansion steps. Further, the Otto and Diesel cycle engines lose efficiency because they do not completely expand high-pressure gases, and simply throttle the waste gases to the atmosphere.

Reducing the size and complexity, as well as the cost, of Brayton cycle engines is important. In addition, improving the efficiency of Brayton cycle engines and/or their components is important. Manufacturers of Brayton cycle engines are continually searching for better and more economical ways of producing Brayton cycle engines.

SUMMARY OF THE INVENTION

According to one embodiment of the invention, a gerotor apparatus includes a first gerotor, a second gerotor, and a synchronizing system operable to synchronize a rotation of the first gerotor with a rotation of the second gerotor. The synchronizing system includes a cam plate coupled to the first gerotor, wherein the cam plate includes a plurality of cams, and an alignment plate coupled to the second gerotor. The alignment plate includes at least one alignment member, wherein the plurality of cams and the at least one alignment member interact to synchronize a rotation of the first gerotor with a rotation of the second gerotor.

Embodiments of the invention provide a number of technical advantages. Embodiments of the invention may include all, some, or none of these advantages. One technical advantage is a more compact and lightweight Brayton cycle engine having simpler gas flow paths, less loads on bearings, and lower power consumption. Some embodiments have fewer parts than previous Brayton cycle engines. Another advantage is that the present invention introduces a simpler method for regulating leakage from gaps. An additional advantage is

3

that the oil path is completely separated from the high-pressure gas preventing heat transfer from the gas to the oil, or entrainment of oil into the gas. A further advantage is that precision alignment between the inner and outer gerotors may be achieved through a single part (e.g., a rigid shaft). A still further advantage is that drive mechanisms disclosed herein have small backlash and low wear.

Other technical advantages are readily apparent to one skilled in the art from the following figures, descriptions, and claims.

BRIEF DESCRIPTION OF THE DRAWINGS

For a more complete understanding of example embodiments of the present invention and its advantages, reference is now made to the following description, taken in conjunction with the accompanying drawings, in which:

FIG. 1 illustrates a cross-section of an example gerotor apparatus having an integrated synchronizing system in accordance with one embodiment of the invention;

FIG. 2 illustrates an example method for determining the shape of cam plates according to one embodiment of the present invention;

FIG. 3 is a cross-sectional view of a synchronizing system taken through cams and alignment members;

FIG. 4 illustrates a cross-section of an example gerotor apparatus having an integrated synchronizing system in accordance with another embodiment of the invention;

FIG. 5 illustrates a cross-section of an example gerotor apparatus having an integrated synchronizing system in accordance with another embodiment of the invention;

FIG. 6 illustrates a cross-section of an example gerotor apparatus having an integrated synchronizing system in accordance with another embodiment of the invention;

FIG. 7 illustrates a cross-section of an example self-synchronizing gerotor apparatus in accordance with another embodiment of the invention;

FIGS. 8A-8D illustrate cross-sectional views A and B of an outer gerotor and an inner gerotor taken along line A and line B, respectively, shown in FIG. 7, according to various embodiments of the invention;

FIG. 9 illustrates a cross-section of a system including a gerotor apparatus located within a chamber such that a portion of chamber on one side of gerotor apparatus is at a higher pressure than a portion of chamber on the other side of gerotor apparatus, in accordance with one embodiment of the invention;

FIG. 10 illustrates example cross-sections of outlet valve plate taken along line C of FIG. 9 according to two embodiments of the invention;

FIG. 11 illustrates example cross-sections of inlet valve plate and outer gerotor taken along lines D and E, respectively, shown in FIG. 9 according to one embodiment of the invention;

FIG. 12 illustrates an example cross-section of a dual gerotor apparatus according to one embodiment of the invention;

FIG. 13 illustrates an example cross-section of a dual gerotor apparatus having a motor (or generator) according to another embodiment of the invention;

FIG. 14 illustrates an example cross-section of a side-breathing engine system 300j in accordance with one embodiment of the invention;

FIG. 15 illustrates example cross-sections of engine system taken along lines F and G, respectively, shown in FIG. 14 according to one embodiment of the invention;

4

FIG. 16 illustrates an example cross-section of a face-breathing engine system in accordance with one embodiment of the invention;

FIGS. 17A-17D illustrate example cross-sections of an engine system taken along lines H and I, respectively, shown in FIG. 16, according to various embodiments of the invention;

FIG. 18 illustrates an example cross-section of a face-breathing engine system in accordance with another embodiment of the invention;

FIG. 19 illustrates an example cross-section of a face-breathing engine system in accordance with another embodiment of the invention;

FIGS. 20-22 illustrates example cross-sections of face-breathing engine systems in accordance with three other embodiments of the invention;

FIG. 23 illustrates an example cross-section of an engine system in accordance with another embodiment of the invention;

FIG. 24 illustrates an example cross-section of an engine system in accordance with another embodiment of the invention;

FIG. 25 illustrates an example cross-section of an engine system in accordance with another embodiment of the invention;

FIG. 26 illustrates an example cross-section of a compressor-expander system in accordance with another embodiment of the invention;

FIG. 27 illustrates an example cross-section of a gerotor apparatus having a sealing system to reduce fluid (e.g., gas) leakage in accordance with one embodiment of the invention;

FIG. 28 illustrates example cross-sections of three alternative embodiments of a sealing system similar to sealing system shown in FIG. 27;

FIG. 29 illustrates a method of forming a sealing system in accordance with one embodiment of the invention;

FIG. 30 illustrates an example cross-section of a liquid-processing gerotor apparatus in accordance with one embodiment of the invention;

FIGS. 31A-31D illustrate example cross-sections of a liquid-processing gerotor apparatus taken along lines J and K, respectively, shown in FIG. 30, according to various embodiments of the invention;

FIG. 32 illustrates example cross-sections of valve plate of liquid-processing gerotor apparatus shown in FIG. 30 according to two different embodiments of the invention;

FIG. 33 illustrates an example cross-section of a liquid-processing gerotor apparatus in accordance with another embodiment of the invention;

FIG. 34 illustrates an example cross-section of a dual gerotor apparatus having an integrated motor or generator, according to another embodiment of the invention;

FIG. 35A illustrates an example cross-section of a dual gerotor apparatus having an integrated motor or generator, according to another embodiment of the invention;

FIG. 35B illustrates an example cross-section of a dual gerotor apparatus having an integrated motor or generator, according to another embodiment of the invention;

FIG. 36 illustrates example cross-sections of dual gerotor apparatuses, according to other embodiments of the invention;

FIG. 37 illustrates example cross-sections of dual gerotor apparatuses, according to other embodiments of the invention;

FIG. 38 illustrates an example cross-section of a face-breathing engine system in accordance with one embodiment of the invention;

5

FIG. 39 illustrates example cross-sectional views S, T and D of engine system taken along lines S, T and D, respectively, shown in FIG. 38 according to one embodiment of the invention;

FIG. 40 illustrates example cross-sectional views V, W and X of engine system taken along lines V, W and X, respectively, shown in FIG. 38 according to one embodiment of the invention;

FIG. 41 illustrates example cross-sectional views Y and Z of engine system taken along lines Y and Z, respectively, shown in FIG. 38 according to one embodiment of the invention;

FIG. 42 illustrates an example cross-section of a gerotor apparatus including a synchronizing system in accordance with one embodiment of the invention;

FIG. 43 illustrates a cross-section view of gerotor apparatus taken through line AA shown in FIG. 42;

FIG. 44 illustrates an example cross-section of a gerotor apparatus including a synchronizing system in accordance with one embodiment of the invention;

FIG. 45 illustrates a cross-section view of gerotor apparatus taken through line BB shown in FIG. 44;

FIG. 46, exit pipe includes a projecting portion that projects upward into inner gerotor, thereby blocking one of the passageways at certain times during the rotation of inner gerotor;

FIGS. 46-49 illustrate a gerotor apparatus according to one embodiment of the invention that is based upon;

FIG. 50 illustrates a gerotor apparatus according to another embodiment of the invention, which may only function as a compressor;

FIG. 51 illustrates a gerotor apparatus according to another embodiment of the invention, which may only function as a compressor;

FIG. 52 illustrates a gerotor apparatus according to another embodiment of the invention;

FIGS. 53-55 illustrate a gerotor apparatus according to another embodiment of the invention;

FIG. 56 illustrates a gerotor apparatus according to another embodiment of the invention;

FIG. 57 illustrates a gerotor apparatus according to another embodiment of the invention;

FIG. 58 illustrates a gerotor apparatus according to another embodiment of the invention;

FIG. 59 illustrates a gerotor apparatus according to another embodiment of the invention;

FIG. 60 illustrates a gerotor apparatus according to another embodiment of the invention;

FIG. 61 illustrates a gerotor apparatus according to another embodiment of the invention;

FIG. 62 illustrates a gerotor apparatus according to another embodiment of the invention;

FIG. 63 illustrates a gerotor apparatus according to another embodiment of the invention;

FIG. 64 illustrates a gerotor apparatus according to another embodiment of the invention;

FIG. 65 illustrates a gerotor apparatus according to another embodiment of the invention;

FIG. 66 illustrates a gerotor apparatus according to another embodiment of the invention;

FIG. 67 illustrates a gerotor apparatus according to another embodiment of the invention;

FIG. 68 illustrates a gerotor apparatus according to another embodiment of the invention;

FIG. 69 illustrates a gerotor apparatus according to another embodiment of the invention;

6

FIG. 70 shows a method by which a track may be scribed onto an inner gerotor, such as inner gerotor, according to an embodiment of the invention;

FIG. 71 illustrates a gerotor apparatus according to another embodiment of the invention;

FIG. 72 shows pegs located on outer gerotor sliding along track, according to an embodiment of the invention;

FIG. 73 illustrates a gerotor apparatus according to another embodiment of the invention;

FIG. 74 illustrates a gerotor apparatus according to another embodiment of the invention;

FIG. 75 illustrates a gerotor apparatus according to another embodiment of the invention;

FIG. 76 shows a plurality of pegs and a track for gerotor apparatus, according to an embodiment of the invention;

FIGS. 77-80 illustrate a face-breathing engine system in accordance with one embodiment of the invention;

FIGS. 81-86 illustrate a face-breathing engine system in accordance with another embodiment of the invention;

FIG. 87 shows an inner gerotor having a plurality of notches that provide extra area for gases to leave through the exhaust port allowing for more efficient breathing, according to an embodiment of the invention;

FIG. 88 shows support rings or strengthening bands that wrap around an outer gerotor that provide support to the wall of outer gerotor, according to an embodiment of the invention;

FIG. 89 shows that seals require notches to accommodate strengthening bands, according to an embodiment of the invention;

FIG. 90 shows a conventional sealing system for a tip-breathing gerotor, according to an embodiment of the invention;

FIG. 91 illustrates a face-breathing gerotor apparatus according to one embodiment of the invention that allows for an upper valve plate and a lower valve plate at opposite ends thereof;

FIG. 92 illustrates a face-breathing gerotor apparatus according to one embodiment of the invention that allows for an upper valve plate and a lower valve plate at opposite ends thereof;

FIG. 93 illustrates a face-breathing gerotor apparatus according to one embodiment of the invention that allows for an upper valve plate and a lower valve plate at opposite ends thereof;

FIG. 94 illustrates a face-breathing gerotor apparatus according to one embodiment of the invention that allows for an upper valve plate and a lower valve plate at opposite ends thereof;

FIG. 95 shows that a gap opens up at the top tip of inner gerotor, according to an embodiment of the invention;

FIG. 96 shows that a phase-shifted set of tips may be added to an outer gerotor of a synchronization system thereby giving additional contacting surfaces which spread the load over a wider surface area, according to an embodiment of the invention;

FIG. 97 shows that a plurality of tips of an inner synchronization gerotor may be comprised of full cylinders, according to an embodiment of the invention;

FIG. 98 shows even more phase-shifted sets of tips may be added to both the outer gerotor and inner gerotor, respectively, according to an embodiment of the invention;

FIG. 99 shows that this may be reversed; the male tips may be on the outer gerotor and the female tips on the inner gerotor, according to an embodiment of the invention;

FIG. 100 illustrates a face-breathing gerotor apparatus according to another embodiment of the invention;

FIG. 101 illustrates a face-breathing gerotor apparatus according to another embodiment of the invention;

FIG. 102 illustrates a face-breathing gerotor apparatus according to another embodiment of the invention;

FIG. 103 illustrates a face-breathing gerotor apparatus according to another embodiment of the invention; and

FIG. 104 shows that liquid water may be added to a combustor when a power boost is desired.

DETAILED DESCRIPTION OF EXAMPLE EMBODIMENTS OF THE INVENTION

FIGS. 1 through 104 below illustrate example embodiments of a gerotor apparatus within the teachings of the present invention. Generally, the following detailed description describes gerotor apparatuses as being used in the context of a gerotor compressor; however, some of the following gerotor apparatuses may function equally as well as gerotor expanders or other suitable gerotor apparatuses. In addition, the present invention contemplates that the gerotor apparatuses described below may be utilized in any suitable application; however, the gerotor apparatuses described below are particularly suitable for a quasi-isothermal Brayton cycle engine, such as the one described in U.S. Pat. No. 6,336,317 B1 ("the '317 patent") issued Jan. 8, 2002. The '317 patent, which is herein incorporated by reference, describes the general operation of a gerotor compressor and/or a gerotor expander. Hence, the operation of some of the gerotor apparatuses described below may not be described in detail.

Embodiments of the invention may provide a number of technical advantages, such as a more compact and lightweight design of a gerotor compressor or expander having simpler gas flow paths, less loads on bearings, and lower power consumption. In addition, some embodiments of the invention introduce a simpler method for regulating leakage from gaps, provide for precision alignment between the inner and outer gerotors, and introduce drive mechanisms that have small backlash and low wear. These technical advantages may be facilitated by all, some, or none of the embodiments described below. In addition, in some embodiments, the technology described herein may be utilized in conjunction with the technology described in U.S. patent application Ser. No. 10/359,487, which is herein incorporated by reference.

FIG. 1 illustrates a cross-section of an example gerotor apparatus 10a having an integrated synchronizing system 18a in accordance with one embodiment of the invention. Gerotor apparatus 10a includes a housing 12a, an outer gerotor 14a disposed within housing 12a, an inner gerotor 16a at least partially disposed within outer gerotor 14a, and a synchronizing system 18a at least partially housed within a synchronizing system housing 20a. More particularly, outer gerotor 14a at least partially defines an outer gerotor chamber 30a, and inner gerotor 16a is at least partially disposed within outer gerotor chamber 30a. Gerotor apparatus 10a may be designed as either a compressor or an expander, depending on the embodiment or intended application.

Housing 12a includes a valve plate 40a that includes one or more fluid inlets 42a and one or more fluid outlets 44a. Fluid inlets 42a generally allow fluids, such as gasses, liquids, or liquid-gas mixtures, to enter outer gerotor chamber 30a. Likewise, fluid outlets 44a generally allow fluids within outer gerotor chamber 30a to exit from outer gerotor chamber 30a. Fluid inlets 42a and fluid outlets 44a may have any suitable shape and size. In some embodiments, such as embodiments in which apparatus 10a is used for communicating compressible fluids, such as gasses or liquid-gas mixtures, the total area of the one or more fluid inlets 42a is different than the total

area of the one or more fluid outlets 44a. In embodiments in which apparatus 10a is a compressor, the total area of fluid inlets 42a may be greater than the total area of fluid outlets 44a. Conversely, in embodiments in which apparatus 10a is an expander, the total area of fluid inlets 42a may be less than the total area of fluid outlets 44a.

As shown in FIG. 1, outer gerotor 14a may be rigidly coupled to a first shaft 50a having a first axis, which shaft 50a may be rotatably coupled to a hollow cylindrical portion of housing 12a, such by one or more ring-shaped bearings 52a. Thus, first shaft 50a and outer gerotor 14a may rotate together about the first axis relative to housing 12a and inner gerotor 16a. In some embodiments, first shaft 50a is a drive shaft operable to drive the operation of gerotor apparatus 10a. Inner gerotor 16a may be rotatably coupled to a second shaft 54a having a second axis offset from (i.e., not aligned with) the first axis. Second shaft 54a may be rigidly coupled to, or integral with, housing 12a, such as by one or more ring-shaped bearings 56a. Thus, inner gerotor 16a may rotate together about the second axis relative to housing 12a and outer gerotor 14a.

In this embodiment, synchronizing system 18a includes a cam plate 22a including one or more cams 24a interacting with an alignment plate 26a including one or more alignment members 28a. Cam plate 22a is rigidly coupled to inner gerotor 16a, and alignment plate 26a is rigidly coupled to outer gerotor 14a via first shaft 50a. In alternative embodiments, cam plate 22a may be coupled to outer gerotor 14a and alignment plate 26a may be coupled to inner gerotor 16a. Cam plate 22a and alignment plate 26a cooperate to synchronize the relative motion of outer gerotor 14a and inner gerotor 16a. During operation of gerotor apparatus 10a, alignment members 28a ride against the surfaces of cams 24a, which synchronizes the relative motion of outer gerotor 14a and inner gerotor 16a. Alignment members 28a may include pegs or any other suitable members that may interact with cams 24a. Synchronizing system 18a may include a lubricant 60a operable to reduce friction between cams 24a and alignment members 28a. Synchronizing system 18a is discussed in greater detail below with reference to FIGS. 2 and 3.

As discussed above, synchronizing system 18a may be partially or substantially housed within synchronizing system housing 20a. In this embodiment, synchronizing system housing 20a is coupled to first axis 50a and second axis 54a and, because first axis 50a and second axis 54a are offset from each other, synchronizing system housing 20a is restricted from rotating relative to housing 12a. Synchronizing system housing 20a may be operable to restrict lubricant 60a from flowing into the portions of outer gerotor chamber 30a through which fluids are communicated during the operation of gerotor apparatus 10a. Such portions of outer gerotor chamber 30a are indicated in FIG. 1 as fluid-flow passageways 32a. Thus, synchronizing system housing 20a may substantially prevent lubricant 60a from mixing with fluids flowing through fluid-flow passageways 32a, and vice versa.

FIG. 2 illustrates an example method for determining the shape of cams 24a of cam plate 22a according to one embodiment of the present invention. As shown in FIG. 2, a rigid bar 70 is attached to an outer gerotor 14. As inner gerotor 16 and outer gerotor 14 rotate, a point 72 located on bar 70 traces a path 74 (or scribes a line) on inner gerotor 16, the shape of which path 74 is shown in FIG. 3 as a dashed line.

FIG. 3 is a cross-sectional view of synchronizing system 18a taken through cams 24a and alignment members (here, pegs) 28a. In some embodiments, the number of cams 24a on cam plate 22a is different than the number of alignment members 28a on alignment plate 26a. For example, in a

particular embodiment, cam plate 22a includes seven cams 24a, while alignment plate 26a includes six alignment members 28a. The shape of cams 24a corresponds with the path 74 determined as described above. In this embodiment, each cam 24a has a “dog bone” shape including a first surface 80a and a second surface 82a that guide alignment members 28a along portions of path 74 as outer gerotor 14a and inner gerotor 16a rotate relative to each other, thus keeping outer gerotor 14a and inner gerotor 16a in alignment. The “dog bone” shape may have a narrower width across an inner portion than the width at either end of the shape.

In the embodiment shown in FIG. 3, at any instant during the rotation of outer gerotor 14a and inner gerotor 16a, at least two alignment members 28a are touching the first surface 80a or second surface 82a of one of the cams 24a. If cam plate 22a is held rigid, one alignment member 28a prevents alignment plate 26a from rotating clockwise, and another alignment member 28a prevents alignment plate 26a from rotating counter-clockwise. When cam plate 22a rotates about its center, cams 24a and alignment members 28a cooperate to synchronize the motion of outer gerotor 14a and inner gerotor 16a.

FIG. 4 illustrates a cross-section of an example gerotor apparatus 10b having an integrated synchronizing system 18b in accordance with another embodiment of the invention. Like gerotor apparatus 10a shown in FIG. 1, gerotor apparatus 10b includes a housing 12b, an outer gerotor 14b disposed within housing 12b, an inner gerotor 16b at least partially disposed within outer gerotor 14b, and a synchronizing system 18b including a cam plate 22b and an alignment plate 26b. Outer gerotor 14b at least partially defines an outer gerotor chamber 30b, and inner gerotor 16b is at least partially disposed within outer gerotor chamber 30b. Outer gerotor 14b is rigidly coupled to a first shaft 50b, which is rotatably coupled to housing 12b, and inner gerotor 16b is rotatably coupled to a second shaft 54b rigidly coupled to, or integral with, housing 12b. Gerotor apparatus 10b may be designed as either a compressor or an expander, depending on the embodiment or intended application.

However, unlike gerotor apparatus 10a, synchronizing system 18b of gerotor apparatus 10b is partially or substantially enclosed by a dam 90b and a plug 92b. Dam 90b may comprise a cylindrical member rigidly coupled to, or integral with, inner gerotor 16b, and plug 92b may also comprise a cylindrical member. Plug 92b may be coupled to dam 90b and shaft 50b, such as by one or more bearings, such that plug 92b forms a seal between inner gerotor 16b and shaft 50b. In the embodiment shown in FIG. 4, plug 92b is coupled to shaft 50b by a first, smaller bearing 94b and to dam 90b by a second, larger bearing 96b. Dam 90b and plug 92b may be operable to restrict a lubricant 60b from flowing into fluid-flow passageways 32b of outer gerotor chamber 30b. Thus, dam 90b and plug 92b may substantially prevent lubricant 60b from mixing with fluids flowing through fluid-flow passageways 32b, and vice versa.

FIG. 5 illustrates a cross-section of an example gerotor apparatus 10c having an integrated synchronizing system 18c in accordance with another embodiment of the invention. Like gerotor apparatus 10a shown in FIG. 1, gerotor apparatus 10c includes a housing 12c, an outer gerotor 14c disposed within housing 12c, an inner gerotor 16c at least partially disposed within outer gerotor 14c, and a synchronizing system 18c including a number of cams 24c interacting with a number of alignment members 28c. Outer gerotor 14c at least partially defines an outer gerotor chamber 30c, and inner gerotor 16c is at least partially disposed within outer gerotor chamber 30c. Outer gerotor 14c and inner gerotor 16c are

rotatably coupled to a single shaft 100c rigidly coupled to housing 12c. In particular, outer gerotor 14c is rotatably coupled to a first portion 102c of shaft 100c having a first axis about which outer gerotor 14c rotates, and inner gerotor 16c is rotatably coupled to a second portion 104c of shaft 100c having a second axis about which inner gerotor 16c rotates, the second axis being offset from the first axis. Gerotor apparatus 10c may be designed as either a compressor or an expander, depending on the embodiment or intended application.

Synchronizing system 18c is partially enclosed by a dam 90c. Dam 90c may comprise a cylindrical member rigidly coupled to, or integral with, inner gerotor 16c proximate a first end 110c of inner gerotor 16c. In this embodiment, dam 90c does not completely seal synchronizing system 18c from portions of outer gerotor chamber 30c through which fluids are communicated during the operation of gerotor apparatus 10c, indicated in FIG. 5 as fluid-flow passageways 32c. A lubricant 60c may be used to lubricate synchronizing system 18c. In this embodiment, lubricant 60c may be grease or a similar lubricant. Dam 90c may help keep lubricant 60c from escaping into fluid-flow passageways 32c, thus preventing or reducing the amount of lubricant 60c mixing with fluids flowing through fluid-flow passageways 32b, and vice versa.

FIG. 6 illustrates a cross-section of an example gerotor apparatus 10d having an integrated synchronizing system 18d in accordance with another embodiment of the invention. Gerotor apparatus 10d is similar to gerotor apparatus 10c shown in FIG. 5, including a housing 12d, an outer gerotor 14d, an inner gerotor 16d, and a synchronizing system 18d. Synchronizing system 18d includes an alignment plate 26d rigidly coupled to outer gerotor 14d by a cylindrical member 120d. Gerotor apparatus 10d further includes a dam 90d coupled to, or integral with, inner gerotor 16d, and a plug 92d that cooperates with dam 90d to substantially enclose synchronizing system 18d. Plug 92d may comprise a cylindrical member, and may be coupled to dam 90d and shaft 100d, such as by one or more bearings, such that plug 92d forms a substantial seal between inner gerotor 16d and shaft 100d. In the embodiment shown in FIG. 6, plug 92d is coupled to cylindrical member 120d (and thus to outer gerotor 14d) by a first, smaller bearing 94d, and to dam 90d by a second, larger bearing 96d. Dam 90d and plug 92d may restrict a lubricant 60d from flowing into fluid-flow passageways 32d of outer gerotor chamber 30b. Thus, dam 90d and plug 92d may substantially prevent lubricant 60d from mixing with fluids flowing through fluid-flow passageways 32d, and vice versa.

FIG. 7 illustrates a cross-section of an example self-synchronizing gerotor apparatus 10e in accordance with another embodiment of the invention. Like gerotor apparatus 10a shown in FIG. 1, gerotor apparatus 10e includes a housing 12e, an outer gerotor 14e disposed within housing 12e, an outer gerotor chamber 30e at least partially defined by outer gerotor 14e, and an inner gerotor 16e at least partially disposed within outer gerotor chamber 30e. Outer gerotor 14e and inner gerotor 16e are rotatably coupled to a single shaft 100e rigidly coupled to housing 12e. In particular, outer gerotor 14e is rotatably coupled to a first portion 102e of shaft 100e having a first axis about which outer gerotor 14e rotates, and inner gerotor 16e is rotatably coupled to a second portion 104e of shaft 100e having a second axis about which inner gerotor 16e rotates, the second axis being offset from the first axis. Gerotor apparatus 10e may be designed as either a compressor or an expander, depending on the embodiment or intended application.

Outer gerotor 14e includes an inner surface 130e extending around the inner perimeter of outer gerotor 14e and at least

partially defining outer gerotor chamber 30e. Inner gerotor 16e includes an outer surface 132e extending around the outer perimeter of inner gerotor 16e. As inner gerotor 16e and outer gerotor 14e rotate relative to each other, at least portions of outer surface 132e of inner gerotor 16e contacts at least portions of inner surface 130e of outer gerotor 14e, which synchronizes the rotation of inner gerotor 16e and outer gerotor 14e. Thus, as shown in FIG. 7, outer surface 132e of inner gerotor 16e and inner surface 130e of outer gerotor 14e may provide the synchronization function that is provided by separate synchronization mechanisms 18 discussed herein with regard to other embodiments.

In order to reduce friction and wear between inner gerotor 16e and outer gerotor 14e, at least a portion of (a) outer surface 132e of inner gerotor 16e and/or (b) inner surface 130e of outer gerotor 14e is formed from one or more relatively low-friction materials 134e, which portions may be referred to as low-friction regions 140e. Such low-friction materials 134e may include, for example, a polymer (phenolics, nylon, polytetrafluoroethylene, acetyl, polyimide, polysulfone, polyphenylene sulfide, ultrahigh-molecular-weight polyethylene), graphite, or oil-impregnated sintered bronze. In some embodiments, such as embodiments in which water is provided as a lubricant between outer surface 132e of inner gerotor 16e and inner surface 130e of outer gerotor 14e, low-friction materials 134e may comprise VESCONITE.

Low-friction regions 140e may include portions (or all) of inner gerotor 16e and/or outer gerotor 14e, or low-friction implants coupled to, or integral with, inner gerotor 16e and/or outer gerotor 14e. Depending on the particular embodiment, such low-friction regions 140e may extend around the inner perimeter of outer gerotor 14e and/or the outer perimeter of inner gerotor 16e, or may be located only at particular locations around the inner perimeter of outer gerotor 14e and/or the outer perimeter of inner gerotor 16e, such as proximate the tips of inner gerotor 16e and/or outer gerotor 14e as discussed below with respect to FIG. 8B. As shown in FIG. 7, low-friction regions 140e may extend a slight distance beyond the outer surface 132e of inner gerotor 16e and/or inner surface 130e of outer gerotor 14e such that only the low-friction regions 140e of inner gerotor 16e and/or outer gerotor 14e contact each other. Thus, there may be a narrow gap between the remaining, higher-friction regions 142e of inner gerotor 16e and outer gerotor 14e, as indicated by arrow 144e in FIG. 7. Higher-friction regions 142e may have a higher coefficient of friction than corresponding low-friction regions 134e.

In some embodiments, low-friction regions 140e of inner gerotor 16e and/or outer gerotor 14e may sufficiently reduce friction and wear such that gerotor apparatus 10e may be run dry, or without lubrication. However, in some embodiments, a lubricant 60e is provided to further reduce friction and wear between inner gerotor 16e and outer gerotor 14e. As shown in FIG. 7, shaft 100e may include a shaft lubricant channel 152e and inner gerotor 16e may include one or more inner gerotor lubricant channels 154e terminating at one or more lubricant channel openings 156e in the outer surface 132e of inner gerotor 16e. Lubricant channels 152e and 154e may provide a path for communicating a lubricant 60e through lubricant channel openings 156e such that lubricant 60e may provide lubrication between outer surface 132e of inner gerotor 16e and inner surface 130e of outer gerotor 14e.

Lubricant 60e, as well as any other lubricant discussed here, may include any one or more suitable substances suitable to provide lubrication between multiple surfaces, such as oils, graphite, grease, water, or any other suitable lubricants.

FIGS. 8A-8D illustrate cross-sectional views A and B of outer gerotor 14e and inner gerotor 16e taken along line A and line B, respectively, shown in FIG. 7, according to various embodiments of the invention. In the embodiment shown in FIG. 8A, view A, inner gerotor 16e includes low-friction regions 140e at each tip 160e of inner gerotor 16e. Lubricant channels 154e provide passageways for communicating lubricant 60e through lubricant channel openings 156e such that lubricant 60e may provide lubrication between outer surface 132e of inner gerotor 16e and inner surface 130e of outer gerotor 14e. Outer gerotor 14e includes a low-friction region 140e extending around the inner perimeter of outer gerotor 14e and defining inner surface 130e of outer gerotor 14e. As discussed above, as inner gerotor 16e and outer gerotor 14e rotate relative to each other, at least portions of outer surface 132e of inner gerotor 16e contact inner surface 130e of outer gerotor 14e, which synchronizes the rotation of inner gerotor 16e and outer gerotor 14e.

View B of FIG. 8A is a cross-section taken through the portion of inner gerotor 16e and outer gerotor 14e not including low-friction region 140e. As discussed above regarding FIG. 7, a narrow gap 144e may be maintained between outer surface 132e of inner gerotor 16e and inner surface 130e of outer gerotor 14e. Thus, contact (and thus friction and wear) between higher-friction regions 142e of inner gerotor 16e and outer gerotor 14e may be substantially reduced or eliminated.

In the embodiment shown in FIG. 8B, view A, inner gerotor 16e includes low-friction regions 140e at each tip 160e of inner gerotor 16e. Lubricant channels 154e provide passageways for communicating lubricant 60e through lubricant channel openings 156e such that lubricant 60e may provide lubrication between outer surface 132e of inner gerotor 16e and inner surface 130e of outer gerotor 14e. Outer gerotor 14e includes a low-friction region 140e proximate each tip 162e of inner surface 130e of outer gerotor 14e. Because a large portion of friction and wear between inner gerotor 16e and outer gerotor 14e occurs at tips 160e and 162e of inner gerotor 16e and outer gerotor 14e, respectively, limiting low-friction regions 140e to areas near tips 160e and 162e may reduce costs where low-friction materials 134e are relatively expensive and/or provide additional structural integrity where low-friction regions 140e are less durable than higher-friction regions 142e. View B of FIG. 8B is similar or identical to View B of FIG. 8A, wherein the complete cross-sections of both inner gerotor 16e and outer gerotor 14e at section B are higher-friction regions 142e.

In the embodiment shown in FIG. 8C, view A, the complete cross-section of inner gerotor 16e at section A is a low-friction region 140e formed from a low-DALOI friction material 134e. Again, lubricant channels 154e provide passageways for communicating lubricant 60e through lubricant channel openings 156e such that lubricant 60e may provide lubrication between outer surface 132e of inner gerotor 16e and inner surface 130e of outer gerotor 14e. Outer gerotor 14e is a higher-friction region 140e formed from a higher-friction material. Providing inner gerotor 16e having a complete cross-section formed from a low-friction material 134e may provide manufacturing advantages over other embodiments that include both low-friction regions 140e and higher-friction regions 142e at a particular cross-section. View B of FIG. 8C is similar or identical to View B of FIG. 8A, wherein the complete cross-sections of both inner gerotor 16e and outer gerotor 14e at section B are higher-friction regions 142e.

In the embodiment shown in FIG. 8D, view A, the complete cross-sections of both inner gerotor 16e and outer gerotor 14e at section A are low-friction regions 140e formed from one or more low-friction materials 134e. Again, lubricant channels

154e provide passageways for communicating lubricant 60e through lubricant channel openings 156e such that lubricant 60e may provide lubrication between outer surface 132e of inner gerotor 16e and inner surface 130e of outer gerotor 14e. View B of FIG. 8D is similar or identical to View B of FIG. 8A, wherein the complete cross-sections of both inner gerotor 16e and outer gerotor 14e at section B are higher-friction regions 142e.

FIG. 9 illustrates a cross-section of a system 190f including a gerotor apparatus 10f located within a chamber 200f such that a portion of chamber 200f on one side of gerotor apparatus 10f is at a higher pressure than a portion of chamber 200f on the other side of gerotor apparatus 10f, in accordance with one embodiment of the invention. Gerotor apparatus 10f is generally located between a first chamber portion 202f and a second chamber portion 204f of chamber 200f, such that gas or other fluids may pass from first chamber portion 202f, through a first face 206f of gerotor apparatus 10f, though one or more fluid flow passageways 32f defined by gerotor apparatus 10f, and through a second face 208f of gerotor apparatus 10f and into second chamber portion 204f.

Gerotor apparatus 10f may be designed as either a compressor or an expander, depending on the embodiment or intended application. A compressible fluid 192f, such as a gas or gas-liquid mixture, may be run through system 190f, including through first chamber portion 202f, gerotor apparatus 10f, and second chamber portion 204f. In embodiments in which gerotor apparatus 10f is a compressor, compressible fluid 192f may flow through first chamber portion 202f at a first pressure, become compressed within gerotor apparatus 10f, and flow through second chamber portion 204f at a second pressure higher than the first pressure. Conversely, in embodiments in which gerotor apparatus 10f is an expander, the compressible fluid 192f may flow through first chamber portion 202f at a first pressure, expand within gerotor apparatus 10f, and flow through second chamber portion 204f at a second pressure lower than the first pressure. In some embodiments, chamber 200f is a vacuum chamber. In some embodiments, system 190f may be a portion of an air conditioning system. In a particular embodiment, system 190f is part of a water-based air conditioning system.

Like gerotor apparatus 10e shown in FIG. 7, gerotor apparatus 10f includes a housing 12f, an outer gerotor 14f disposed within housing 12f, an outer gerotor chamber 30f at least partially defined by outer gerotor 14f, and an inner gerotor 16f at least partially disposed within outer gerotor chamber 30f. Outer gerotor 14f and inner gerotor 16f are rotatably coupled to a single shaft 100f rigidly coupled to housing 12f. In particular, outer gerotor 14f is rotatably coupled to a first portion 102f of shaft 100f having a first axis about which outer gerotor 14f rotates, and inner gerotor 16f is rotatably coupled to a second portion 104f of shaft 100f having a second axis about which inner gerotor 16f rotates, the second axis being offset from the first axis.

Housing 12f includes a fluid outlet plate 40f and a fluid inlet plate 41f. Fluid inlet plate 41f includes at least one inlet opening 214f (see FIG. 11, discussed below) allowing fluids to pass through. Outer gerotor 14f also includes at least one inlet opening 216f (see FIG. 11, discussed below) allowing fluids to pass through during the rotation of outer gerotor 14f. Together, openings 214f and 216f comprise a fluid inlet port 218f allowing fluids (such as gas or water, for example) to flow from first chamber portion 202f into fluid flow passageways 32f of gerotor apparatus 10f, as indicated by arrow 220f. Fluid outlet plate 40f includes at least one outlet opening 224f and/or check valve 230f (see FIG. 10, discussed below) allow-

ing fluids to flow from fluid flow passageways 32f of gerotor apparatus 10f into second chamber portion 204f, as indicated by arrow 226f.

In this particular embodiment, gerotor apparatus 10f is a self-synchronizing gerotor apparatus 10f similar to gerotor apparatus 10e shown in FIG. 7 as discussed above. For example, at least a portion of (a) outer surface 132f of inner gerotor 16f and/or (b) inner surface 130f of outer gerotor 14f of gerotor apparatus 10f may include one or more low-friction regions 140f formed from low-friction materials 134f in order to reduce friction and wear between inner gerotor 16f and outer gerotor 14f, thus allowing outer surface 132f of inner gerotor 16f and inner surface 130f of outer gerotor 14f to synchronize the rotation of inner gerotor 16f and outer gerotor 14f. Low-friction regions 140f may extend a slight distance beyond the outer surface 132f of inner gerotor 16f and/or inner surface 130f of outer gerotor 14f to provide a narrow gap 144f between remaining, higher-friction regions 142f of inner gerotor 16f and outer gerotor 14f such that only the low-friction regions 140f of inner gerotor 16f and/or outer gerotor 14f contact each other. In other embodiments, gerotor apparatus 10f may include a synchronizing system 18f, such as shown in FIGS. 1-6, for example. In addition, in some embodiments, as shown in FIG. 9, a lubricant 60f may be communicated through lubricant channels 152f and 154f to provide lubrication between outer surface 132f of inner gerotor 16f and inner surface 130f of outer gerotor 14f.

FIG. 10 illustrates example cross-sections of outlet valve plate 40f taken along line C of FIG. 9 according to two embodiments of the invention. In the first embodiment, C1, outlet valve plate 40f includes an outlet opening 224f allowing fluids to exit fluid flow passageways 32f into second chamber portion 204f. In some embodiments in which gerotor apparatus 10f is a compressor, the area of outlet opening 224f is smaller than the total area of inlet opening(s) 214f formed in inlet valve plate 41f (see FIG. 11, discussed below).

In the second embodiment, C2, outlet valve plate 40f includes an outlet opening 224f, as well as one or more check valves 230f, allowing fluids to exit fluid flow passageways 32f into second chamber portion 204f. Providing one or more check valves 230f allows various types of fluids 192f to be run through gerotor apparatus 10f, such as gasses, liquids (e.g., water), and gas-liquid mixtures. The area of outlet opening 224f may be smaller than the total area of inlet opening(s) 214f formed in inlet valve plate 41f (see FIG. 11, discussed below). The total area of outlet opening 224f and check valves 230f may be approximately equal to the total area of inlet opening(s) 214f formed in inlet valve plate 41f. The appropriate check valves 230f may open to discharge the particular fluid 192f running through gerotor apparatus 10f. For example, if a low compression ratio is required for the application, all of the check valves 230f may open. If a high compression ratio is required, none of the check valves 230f may open. If an intermediate compression ratio is required, then some of the check valves 230f may open. Check valves 230f may open or close slowly, which is particularly useful for applications that operate at low pressures, such as water-based air conditioning. At low pressures, there may be insufficient force available to rapidly move the mass of the check valve 230f. Check valves 230f may be particularly valuable for protecting compressor apparatus 10f from damage from liquids. For instance, if there is relatively large amount of liquid in the compressor, it may have difficulty exiting outlet opening 224f. In this case, the pressure would rise allowing check valves 230f to pop open and release the liquid, which is non-compressible, which may protect compressor apparatus 10f from damage.

FIG. 11 illustrates example cross-sections of inlet valve plate 41f and outer gerotor 14e taken along lines D and E, respectively, shown in FIG. 9 according to one embodiment of the invention. Inlet valve plate 41f includes one or more inlet opening 214f allowing fluids to enter fluid flow passageways 32f from first chamber portion 202f. In some embodiments in which gerotor apparatus 10f is a compressor, the area of inlet opening 214f is larger than the total area of outlet opening(s) 224f formed in outlet valve plate 40f (see FIG. 10, discussed above). As discussed above, at cross-section E, outer gerotor 14f includes at least one inlet opening 214f (see FIG. 11, discussed below) allowing fluids to pass through during the rotation of outer gerotor 14f. In this embodiment, outer gerotor 14f has a spoked hub shape at cross-section E, forming a plurality of inlet openings 214f. However, the portion of outer gerotor 14f interfacing first chamber portion 202f may be otherwise configured to provide one or more inlet openings 214f allowing fluids to enter fluid flow passageways 32f from first chamber portion 202f.

FIG. 12 illustrates an example cross-section of a dual gerotor apparatus 250g according to one embodiment of the invention. Dual gerotor apparatus 250g includes a housing 12g and an integrated pair of gerotor apparatuses, including a first gerotor apparatus 10g proximate a first face 252g of apparatus 250g and a second gerotor apparatus 10g' proximate a second face 254g of apparatus 250g generally opposite first face 252g. First gerotor apparatus 10g and second gerotor apparatus 10g' may both be compressors, may both be expanders, or may include one expander and one compressor, depending on the particular embodiment or application. Each gerotor apparatus 10g and 10g' may be partially or substantially similar to those otherwise described herein, such as gerotor apparatus 10e shown in FIG. 7 and discussed above, for example.

Like gerotor apparatus 10e shown in FIG. 7, gerotor apparatus 10g includes an outer gerotor 14g disposed within housing 12g, an outer gerotor chamber 30g at least partially defined by outer gerotor 14g, and an inner gerotor 16g at least partially disposed within outer gerotor chamber 30g. Outer gerotor 14g and inner gerotor 16g are rotatably coupled to a single shaft 100g rigidly coupled to housing 12g. In particular, outer gerotor 14g is rotatably coupled to a first portion 102g of shaft 100g having a first axis about which outer gerotor 14g rotates, and inner gerotor 16g is rotatably coupled to a second portion 104g of shaft 100g having a second axis about which inner gerotor 16g rotates, the second axis being offset from the first axis.

Similarly, gerotor apparatus 10g' includes an outer gerotor 14g' disposed within housing 12g, an outer gerotor chamber 30g' at least partially defined by outer gerotor 14g', and an inner gerotor 16g' at least partially disposed within outer gerotor chamber 30g'. Outer gerotor 14g' may be rigidly coupled to, or integral with, outer gerotor 14g of gerotor apparatus 10g. In alternative embodiments, inner gerotor 16g' may be rigidly coupled to, or integral with, inner gerotor 16g of gerotor apparatus 10g. Outer gerotor 14g' and inner gerotor 16g' are rotatably coupled to shaft 100g rigidly coupled to housing 12g. In particular, outer gerotor 14g' is rotatably coupled to first portion 102g of shaft 100g, and inner gerotor 16g' is rotatably coupled to a third portion 105g of shaft 100g having a third axis about which inner gerotor 16g' rotates, the third axis being offset from the first axis. The third axis about which inner gerotor 16g' rotates may be co-axial with the second axis about which inner gerotor 16g rotates.

Housing 12g includes a first valve plate 40g proximate first face 252g of apparatus 250g and operable to control the flow of fluids through first gerotor apparatus 10g, and a second

valve plate 40g' proximate second face 254g of apparatus 250g and operable to control the flow of fluids through second gerotor apparatus 10g'. First valve plate 40g includes at least one fluid inlet 42g allowing fluids to enter fluid flow passageways 32g of gerotor apparatus 10g, and at least one fluid outlet 44g allowing fluids to exit fluid flow passageways 32g of gerotor apparatus 10g. Similarly, second valve plate 40g' includes at least one fluid inlet 42g' allowing fluids to enter fluid flow passageways 32g' of gerotor apparatus 10g', and at least one fluid outlet 44g' allowing fluids to exit fluid flow passageways 32g' of gerotor apparatus 10g'. Having fluid inlets 42g and 42g' and fluid outlets 44g and 44g' at each face 252g and 254g of apparatus 250g doubles the porting area into and out of dual gerotor apparatus 250g, which may provide more efficient fluid flow and/or reduce or minimize porting losses as compared to an apparatus with a single gerotor apparatus 10.

In the embodiment shown in FIG. 12, each of gerotor apparatus 10g and 10g' is a self-synchronizing gerotor apparatus similar to gerotor apparatus 10e shown in FIG. 7 as discussed above. In other embodiments, gerotor apparatus 10g may include a synchronizing system 18g, such as shown in FIGS. 1-6, for example. In addition, in some embodiments, as shown in FIG. 12, a lubricant 60g may be communicated through appropriate lubricant channels to provide lubrication between inner gerotor 16g and outer gerotor 14g, such as described above with reference to FIG. 7.

As shown in FIG. 12, an imbedded motor 260g may drive dual gerotor apparatus 250g by driving rigidly coupled, or integrated, outer gerotors 14g and 14g', which may in turn drive inner gerotors 16g and 16g'. For example, motor 260g may drive one or more magnetic elements 262g coupled to, or integrated with, outer gerotors 14g and 14g'. Motor 260g may comprise any suitable type of motor, such as a permanent magnet motor, a switched reluctance motor (SRM), or an inductance motor, for example. In alternative embodiments, dual gerotor apparatus 250g may include an electric generator 264g (instead of a motor), which may be powered by the rotation of outer gerotors 14g and 14g'.

FIG. 13 illustrates an example cross-section of a dual gerotor apparatus 250h having a motor 260h (or generator 264h) according to another embodiment of the invention. Like dual gerotor apparatus 250g shown in FIG. 12, dual gerotor apparatus 250h includes a housing 12h and an integrated pair of gerotor apparatuses, including a first gerotor apparatus 10h proximate a first face 252h of apparatus 250h and a second gerotor apparatus 10h' proximate a second face 254h of apparatus 250h generally opposite first face 252h. First gerotor apparatus 10h and second gerotor apparatus 10h' may both be compressors, may both be expanders, or may include one expander and one compressor, depending on the particular embodiment or application. Gerotor apparatuses 10h and 10h' may be partially or substantially similar to gerotor apparatuses 10g and 10g' shown in FIG. 12 and described above.

However, unlike dual gerotor apparatus 250g shown in FIG. 12, dual gerotor apparatus 250h includes a rotatable shaft 270h coupled to the rigidly coupled outer gerotors 14h and 14h' by a coupling system 272h such that rotation of rigidly coupled outer gerotors 14h and 14h' causes rotation of shaft 270h and/or vice-versa. In the embodiment shown in FIG. 13, coupling system 272h includes a first gear 274h interacting with a second gear 276h. First gear 274h is rigidly coupled to a cylindrical member 278h rigidly coupled to outer gerotors 14h and 14h'. Second gear 276h is rigidly coupled to rotatable shaft 270h. In other embodiments, coupling system 272h may include a flexible coupling device, such as a chain or belt.

17

Thus, embodiments in which dual gerotor apparatus **250h** includes a motor **260h** and gerotor apparatuses **10h** and **10h'** are compressors, motor **260h** may not only power the compressors, but also power rotating shaft **270h**, which power may be used for other purposes, such as to power auxiliary devices. For example, where dual gerotor apparatus **250h** is used in a water-based air conditioner, rotating shaft **270h** may be used to power one or more pumps.

FIG. **14** illustrates an example cross-section of a side-breathing engine system **300j** in accordance with one embodiment of the invention. Side-breathing engine system **300j** includes a housing **12j**, a compressor gerotor apparatus **10j**, and an expander gerotor apparatus **10j'**. Compressor gerotor apparatus **10j** includes a compressor outer gerotor **14j** disposed within housing **12j**, a compressor outer gerotor chamber **30j** at least partially defined by compressor outer gerotor **14j**, and a compressor inner gerotor **16j** at least partially disposed within compressor outer gerotor chamber **30j**. Similarly, expander gerotor apparatus **10j'** includes an expander outer gerotor **14j'** disposed within housing **12j**, an expander outer gerotor chamber **30j'** at least partially defined by expander outer gerotor **14j'**, and an expander inner gerotor **16j'** at least partially disposed within expander outer gerotor chamber **30j'**.

Compressor outer gerotor **14j** may be rigidly coupled to, or integral with, expander outer gerotor **14j'**. Similarly, compressor inner gerotor **16j** may be rigidly coupled to, or integral with, expander inner gerotor **16j'**. Compressor and expander outer gerotors **14j** and **14j'** and compressor and expander inner gerotors **16j** and **16j'** may be rotatably coupled to a single shaft **100j** rigidly coupled to housing **12j**. In the embodiment shown in FIG. **14**, compressor and expander outer gerotors **14j** and **14j'** are rotatably coupled to first portions **102j** of shaft **100j** having a first axis about which outer gerotors **14j** and **14j'** rotate, and compressor and expander inner gerotors **16j** and **16j'** are rotatably coupled to a second portion **104j** of shaft **100j** having a second axis about which inner gerotors **16j** and **16j'** rotate, the second axis being offset from the first axis.

Compressor gerotor apparatus **10j** and/or expander gerotor apparatus **10j'** may be self-synchronizing, such as described above regarding the various gerotor apparatuses shown in FIGS. 7-13. In the embodiment shown in FIG. **14**, compressor gerotor apparatus **10j** performs the synchronization function for both compressor gerotor apparatus **10j** and expander gerotor apparatus **10j'**. In particular, at least a portion of (a) an outer surface **132j** of compressor inner gerotor **16j** and/or (b) an inner surface **130j** of compressor outer gerotor **14j** may include one or more low-friction regions **140j** formed from low-friction materials **134j** in order to reduce friction and wear between compressor inner gerotor **16j** and compressor outer gerotor **14j**, thus allowing outer surface **132j** of compressor inner gerotor **16j** and inner surface **130j** of compressor outer gerotor **14j** to synchronize the rotation of compressor inner gerotor **16j** and compressor outer gerotor **14j**. Further, because expander inner gerotor **16j'** and expander outer gerotor **14j'** are rigidly coupled to compressor inner gerotor **16j** and compressor outer gerotor **14j**, respectively, the rotation of expander inner gerotor **16j'** and expander outer gerotor **14j'** is also synchronized.

Low-friction regions **140j** of compressor inner gerotor **16j** and/or compressor outer gerotor **14j** may extend a slight distance beyond the outer surface **132j** of compressor inner gerotor **16j** and/or inner surface **130j** of compressor outer gerotor **14j** to provide a narrow gap **144j** between remaining, higher-friction regions **142j** of compressor inner gerotor **16j** and compressor outer gerotor **14j** such that only the low-

18

friction regions **140j** contact each other. The narrow gap **144j** may similarly exist between expander inner gerotor **16j'** and expander outer gerotor **14j'** (which may include only higher-friction regions **142j'**) such that expander inner gerotor **16j'** and expander outer gerotor **14j'** do not touch each other (or touch each other only slightly or occasionally), thus reducing or eliminating friction and wear between expander inner gerotor **16j'** and expander outer gerotor **14j'**. In addition, as shown in FIG. **14**, a lubricant **60j** may be communicated through lubricant channels **152j** and **154j** to provide lubrication between outer surface **132j** of compressor inner gerotor **16j** and inner surface **130j** of compressor outer gerotor **14j**.

In alternative embodiments, expander inner gerotor **16j'** and expander outer gerotor **14j'** may also include low-friction regions **140j'** to provide further synchronization or mechanical support. In general, none, portions, or all of each of compressor inner gerotor **16j**, compressor outer gerotor **14j**, expander inner gerotor **16j'** and/or expander outer gerotor **14j'** may include low-friction regions **140j**. In addition, in some alternative embodiments, compressor gerotor apparatus **10j** and/or expander gerotor apparatus **10j'** may include a synchronizing system **18j**, such as shown in FIGS. 1-6, for example.

As shown in FIGS. **14** and **15**, fluid flows through the sides **306j** and **308j** (rather than the faces) of compressor gerotor apparatus **10j** and expander gerotor apparatus **10j'**. Thus, a first fluid inlet **310j** and a second fluid inlet **312j** are formed in a first side **314j** of housing **12j**, and a first fluid outlet **316j** and a second fluid outlet **318j** are formed in a second side **320j** of housing **12j**. One or more compressor gerotor openings **324j** are formed in the outer perimeter of compressor outer gerotor **14j**, and one or more expander gerotor openings **326j** are formed in the outer perimeter of expander outer gerotor **14j'**. First fluid inlet **310j** is operable to communicate fluid into compressor outer gerotor chamber **30j** through compressor gerotor openings **324j**, and first fluid outlet **316j** is operable to communicate the fluid out of compressor outer gerotor chamber **30j** through compressor gerotor openings **324j**. Similarly, second fluid inlet **312j** is operable to communicate fluid into expander outer gerotor chamber **30j'** through expander gerotor openings **324j'**, and second fluid outlet **318j** is operable to communicate the fluid out of expander outer gerotor chamber **30j'** through, expander gerotor openings **326j**.

FIG. **15** illustrates example cross-sections of engine system **300j** taken along lines F and G, respectively, shown in FIG. **14** according to one embodiment of the invention. As shown in FIG. **15**, section F, compressor gerotor openings **324j** may be formed in the perimeter of compressor outer gerotor **14j** at each tip **162j** of compressor outer gerotor chamber **30j**. Low-friction regions **140j** are formed at each tip **160j** of compressor inner gerotor **16j**, and around the inner perimeter of compressor outer gerotor **14j** defining inner surface **130j** of compressor outer gerotor **14j**. Lubricant channels **154j** provide passageways for communicating lubricant **60j** through lubricant channel openings **156j** at each tip **160j** such that lubricant **60j** may provide lubrication between compressor inner gerotor **16j** and compressor outer gerotor **14j**. As shown in FIG. **15**, section G, expander gerotor openings **326j** may be formed in the perimeter of expander outer gerotor **14j'** at each tip **162j'** of expander outer gerotor chamber **30j'**.

FIG. **16** illustrates an example cross-section of a face-breathing engine system **300k** in accordance with one embodiment of the invention. Engine system **300k** includes a housing **12k**, a compressor gerotor apparatus **10k** and an expander gerotor apparatus **10k'**. Compressor gerotor apparatus **10k** includes a compressor outer gerotor **14k** disposed within housing **12k**, a compressor outer gerotor chamber **30k**

19

at least partially defined by compressor outer gerotor **14k**, and a compressor inner gerotor **16k** at least partially disposed within compressor outer gerotor chamber **30k**. Similarly, expander gerotor apparatus **10k'** includes an expander outer gerotor **14k'** disposed within housing **12k**, an expander outer gerotor chamber **30k'** at least partially defined by expander outer gerotor **14k'**, and an expander inner gerotor **16k'** at least partially disposed within expander outer gerotor chamber **30k'**.

Compressor outer gerotor **14k** may be rigidly coupled to, or integral with, expander outer gerotor **14k'**. Similarly, compressor inner gerotor **16k** may be rigidly coupled to, or integral with, expander inner gerotor **16k'**. Compressor and expander inner gerotors **16k** and **16k'** may be rigidly coupled to a shaft **100k** that is rotatably coupled to the inside of a cylindrical portion **330k** of housing **12k** by one or more bearings. Compressor and expander outer gerotors **14k** and **14k'** may be rotatably coupled to an inner perimeter of housing **12k** by one or more bearings.

Unlike side-breathing engine system **300j** shown in FIGS. **14-15**, face-breathing engine system **300k** shown in FIG. **16** breathes through a first face **252k** and second face **254k** of system **300k**. Housing **12k** includes a compressor valve plate **40k** proximate first face **252k** of system **300k** and operable to control the flow of fluids through compressor gerotor apparatus **10k**, and an expander valve plate **40k'** proximate second face **254k** of system **300k** and operable to control the flow of fluids through expander gerotor apparatus **10k'**. Compressor valve plate **40k** includes at least one compressor fluid inlet **42k** allowing fluids to enter fluid flow passageways **32k** of compressor gerotor apparatus **10k**, and at least one compressor fluid outlet **44k** allowing fluids to exit fluid flow passageways **32k** of compressor gerotor apparatus **10k**. Similarly, expander valve plate **40k'** includes at least one expander fluid inlet **42k'** allowing fluids to enter fluid flow passageways **32k'** of expander gerotor apparatus **10k'**, and at least one expander fluid outlet **44k'** allowing fluids to exit fluid flow passageways **32k'** of expander gerotor apparatus **10k'**.

Compressor gerotor apparatus **10k** and/or expander gerotor apparatus **10k'** of engine system **300k** shown in FIG. **16** may be self-synchronizing, such as described above regarding the various gerotor apparatuses shown in FIGS. **7-13**. Instead or in addition, compressor gerotor apparatus **10k** and/or expander gerotor apparatus **10k'** may include a synchronizing system **18**, such as discussed above regarding FIGS. **1-6**, for example. As discussed above regarding engine system **300j**, compressor gerotor apparatus **10k** of engine system **300k** may include one or more low-friction regions **140k** operable to perform the synchronization function for both compressor gerotor apparatus **10k** and expander gerotor apparatus **10k'**. In addition, as shown in FIG. **16**, a lubricant **60k** may be communicated through lubricant channels **154k** to provide lubrication between compressor inner gerotor **16k** and compressor outer gerotor **14k**.

FIGS. **17A-17D** illustrate example cross-sections of engine system **300k** taken along lines H and I, respectively, shown in FIG. **16**, according to various embodiments of the invention. As shown in FIG. **17A**, section H, low-friction regions **140k** are formed at each tip **160k** of compressor inner gerotor **16k**, and around the inner perimeter of compressor outer gerotor **14k** defining inner surface **130k** of compressor outer gerotor **14k**. Remaining portions of compressor inner gerotor **16k** and compressor outer gerotor **14k** may include higher-friction regions **142k**. Lubricant channels **154k** provide passageways for communicating lubricant **60k** through lubricant channel openings **156k** at each tip **160k** of compressor inner gerotor **16k** such that lubricant **60k** may provide

20

lubrication between compressor inner gerotor **16k** and compressor outer gerotor **14k**. As shown in FIG. **17A**, section I, all of expander inner gerotor **16k'** and expander outer gerotor **14k'** may be a higher-friction region **142k**.

As shown in FIG. **17B**, section H, low-friction regions **140k** are formed at each tip **160k** of compressor inner gerotor **16k**. Lubricant channels **154k** provide passageways for communicating lubricant **60k** through lubricant channel openings **156k** at each tip **160k** of compressor inner gerotor **16k**, such that lubricant **60k** may provide lubrication between compressor inner gerotor **16k** and compressor outer gerotor **14k**. Compressor outer gerotor **14k** includes a low-friction region **140k** proximate each tip **162k** of inner surface **130k** of compressor outer gerotor **14k**. Because a large portion of friction and wear between compressor inner gerotor **16k** and compressor outer gerotor **14k** occurs at the tips **160k** and **162k** of compressor inner gerotor **16k** and compressor outer gerotor **14k**, respectively, limiting low-friction regions **140k** to areas near such tips **160k** and **162k** may reduce costs associated where low-friction materials **134k** are relatively expensive and/or provide additional structural integrity where low-friction regions **140k** are less durable than higher-friction regions **142k**. As shown in FIG. **17B**, section I, all of expander inner gerotor **16k'** and expander outer gerotor **14k'** may be a higher-friction region **142k**.

As shown in FIG. **17C**, section H, the complete cross-section of compressor inner gerotor **16k** is a low-friction region **140k**, while the complete cross-section of compressor outer gerotor **14k** is a higher-friction region **142k**. As shown in FIG. **17C**, section I, all of expander inner gerotor **16k'** and expander outer gerotor **14k'** may be a higher-friction region **142k**.

As shown in FIG. **17D**, section H, the complete cross-section of both compressor inner gerotor **16k** and compressor outer gerotor **14k** is a low-friction region **140k**. As shown in FIG. **17D**, section I, all of expander inner gerotor **16k'** and expander outer gerotor **14k'** may be a higher-friction region **142k**.

FIG. **18** illustrates an example cross-section of a face-breathing engine system **300m** in accordance with another embodiment of the invention. Like engine system **300k** shown in FIG. **16**, engine system **300m** includes a housing **12m**, a compressor gerotor apparatus **10m** and an expander gerotor apparatus **10m'**. Compressor gerotor apparatus **10m** includes a compressor outer gerotor **14m** disposed within housing **12m**, a compressor outer gerotor chamber **30m** at least partially defined by compressor outer gerotor **14m**, and a compressor inner gerotor **16m** at least partially disposed within compressor outer gerotor chamber **30m**. Similarly, expander gerotor apparatus **10m'** includes an expander outer gerotor **14m'** disposed within housing **12m**, an expander outer gerotor chamber **30m'** at least partially defined by expander outer gerotor **14m'**, and an expander inner gerotor **16m'** at least partially disposed within expander outer gerotor chamber **30m'**.

In this embodiment, compressor inner gerotor **16m** is rigidly coupled to, or integral with, expander inner gerotor **16m'**. In particular, compressor and expander inner gerotors **16m** and **16m'** are rigidly coupled to a shaft **100m** that is rotatably coupled to the inside of a cylindrical portion **330m** of housing **12m** by one or more bearings. In addition, compressor outer gerotor **14m** is rigidly coupled to, or integral with, expander outer gerotor **14m'**. In particular, compressor and expander outer gerotors **14m** and **14m'** are rigidly coupled to, or integral with, a cylindrical outer gerotor support member **334m** having an outer diameter, indicated as **D1**, that is smaller than the outer diameter of the compressor and expander outer gerotors

14*m* and 14*m'*, indicated as D2. In some embodiments, D1 is less than 1/2 of D2. In particular embodiments, D1 is less than 1/3 of D2. Outer gerotor support member 334*m* is rotatably coupled to one or more extension members 336*m* of housing 12*m* by one or more ring-shaped bearings 340*m*. As shown in FIG. 18, ring-shaped bearings 340*m* have an outer diameter, indicated as D3, that is smaller than the outer diameter, D2, of outer gerotors 14*m* and 14*m'*. In some embodiments, D3 is less than 1/2 of D2. Using bearings 340*m* having smaller diameters than that of outer gerotors 14*m* and 14*m'* reduces the amount of power lost by bearings 340*m* during operation of system 300*m*, and thus the amount of heat generated by bearings 340*m*. The smaller the diameter of bearings 340*m*, the less power lost and heat generated by bearings 340*m*.

Like face-breathing engine system 300*k* shown in FIG. 16, face-breathing engine system 300*m* shown in FIG. 18 breathes through a first face 252*m* and second face 254*m* of system 300*m*. Housing 12*m* includes a compressor valve plate 40*m* proximate first face 252*m* of system 300*m* operable to control the flow of fluids through compressor gerotor apparatus 10*m*, and an expander valve plate 40*m'* proximate second face 254*m* of system 300*m* operable to control the flow of fluids through expander gerotor apparatus 10*m'*. Compressor valve plate 40*m* includes at least one compressor fluid inlet 42*m* allowing fluids to enter fluid flow passageways 32*m* of compressor gerotor apparatus 10*m*, and at least one compressor fluid outlet 44*m* allowing fluids to exit fluid flow passageways 32*m* of gerotor apparatus 10*m*. Similarly, expander valve plate 40*m'* includes at least one expander fluid inlet 42*m'* allowing fluids to enter fluid flow passageways 32*m'* of expander gerotor apparatus 10*m'*, and at least one expander fluid outlet 44*m'* allowing fluids to exit fluid flow passageways 32*m'* of expander gerotor apparatus 10*m'*.

Compressor gerotor apparatus 10*m* and/or expander gerotor apparatus 10*m'* of engine system 300*m* shown in FIG. 18 may be self-synchronizing, such as described above regarding the various gerotor apparatuses shown in FIGS. 7-16. Instead or in addition, compressor gerotor apparatus 10*m* and/or expander gerotor apparatus 10*m'* may include a synchronizing system 18, such as discussed above regarding FIGS. 1-6, for example. As discussed above regarding engine system 300*j*, compressor gerotor apparatus 10*m* of engine system 300*m* may include one or more low-friction regions 140*m* operable to perform the synchronization function for both compressor gerotor apparatus 10*m* and expander gerotor apparatus 10*m'*. In addition, as shown in FIG. 16, a lubricant 60*m* may be communicated through lubricant channels to provide lubrication between compressor inner gerotor 16*m* and compressor outer gerotor 14*m*.

In operation, torque generated by system 300*m* is transmitted from outer gerotors 14*m* and 14*m'* to inner gerotors 16*m* and 16*m'*, and then to the rotating output shaft 100*m*, which shaft power may be used to power any suitable device or devices. As with various other engine systems 300 shown and described herein, in some embodiments, the same mechanical arrangement of engine system 300*m* could be used in a reverse-Brayton cycle heat pump in which power is input to shaft 100*m*.

FIG. 19 illustrates an example cross-section of a face-breathing engine system 300*n* in accordance with another embodiment of the invention. Like engine system 300*m* shown in FIG. 18, engine system 300*n* includes a housing 12*n*, a compressor gerotor apparatus 10*n* and an expander gerotor apparatus 10*n'*. Compressor gerotor apparatus 10*n* includes a compressor outer gerotor 14*n* disposed within housing 12*n*, a compressor outer gerotor chamber 30*n* at least partially defined by compressor outer gerotor 14*n*, and a

compressor inner gerotor 16*n* at least partially disposed within compressor outer gerotor chamber 30*n*. Similarly, expander gerotor apparatus 10*n'* includes an expander outer gerotor 14*n'* disposed within housing 12*n*, an expander outer gerotor chamber 30*n'* at least partially defined by expander outer gerotor 14*n'*, and an expander inner gerotor 16*n'* at least partially disposed within expander outer gerotor chamber 30*n'*.

Like engine system 300*m* shown in FIG. 18, compressor and expander inner gerotors 16*n* and 16*n'* are rigidly coupled to a shaft 100*n* that is rotatably coupled to housing 12*n* by one or more bearings, and compressor and expander outer gerotors 14*n* and 14*n'* are rigidly coupled to, or integral with, a cylindrical outer gerotor support member 334*n* that is rotatably coupled to housing 12*n* by one or more ring-shaped bearings 340*n*.

Like face-breathing engine system 300*m* shown in FIG. 18, face-breathing engine system 300*n* shown in FIG. 19 breathes through at least one compressor fluid inlet 42*n* and at least one compressor fluid outlet 44*n* at a first face 252*n* of system 300*n*, and through at least one expander fluid inlet 42*n'* and at least one expander fluid outlet 44*n'* at a second face 254*n* of system 300*n*. Compressor gerotor apparatus 10*n* and/or expander gerotor apparatus 10*n'* of engine system 300*n* shown in FIG. 19 may be self-synchronizing, such as described above regarding the various gerotor apparatuses shown in FIGS. 7-18. Instead or in addition, compressor gerotor apparatus 10*n* and/or expander gerotor apparatus 10*n'* may include a synchronizing system 18, such as discussed above regarding FIGS. 1-6, for example. In addition, as shown in FIG. 19, a lubricant 60*n* may be communicated through lubricant channels to provide lubrication between compressor inner gerotor 16*n* and compressor outer gerotor 14*n*.

Unlike engine system 300*m* shown in FIG. 18, engine system 300*n* does not provide shaft output power (to shaft 100*m* or otherwise). Instead, compressor gerotor apparatus 10*n* of engine system 300*n* is oversized such that power generated by system 300*n* is output in the form of compressed fluid (such as compressed air, for example) exiting compressor outer gerotor chamber 30*n* through compressor fluid outlet 44*n*, as indicated by arrow 344*n*. Thus, this embodiment may be useful for applications in which compressed air or other gas is the desired product, such as a fuel-powered compressor or jet engine, for example. In some embodiments, a similar mechanical arrangement of engine system 300*n* could be used in a reverse-Brayton cycle heat pump in which power is input to shaft 100*n*.

FIGS. 20-22 illustrates example cross-sections of face-breathing engine systems 300*o*, 300*p*, and 300*q* in accordance with three other embodiments of the invention. Engine systems 300*o*/300*p*/300*q* are similar to engine system 300*m* shown in FIG. 18, except that power is transmitted to an external shaft 270 rather than to internal shaft 100, as discussed in greater detail below.

Like engine system 300 shown in FIG. 18, each of engine systems 300*o*/300*p*/300*q* shown in FIGS. 20-22 include a housing 12*o*/12*p*/12*q*, a compressor gerotor apparatus 10*o*/10*p*/10*q* and an expander gerotor apparatus 10*o'*/10*p'*/10*q'*. Compressor gerotor apparatus 10*o*/10*p*/10*q* includes a compressor outer gerotor 14*o*/14*p*/14*q* disposed within housing 12*o*/12*p*/12*q*, a compressor outer gerotor chamber 30*o*/30*p*/30*q* at least partially defined by compressor outer gerotor 14*o*/14*p*/14*q*, and a compressor inner gerotor 16*o*/16*p*/16*q* at least partially disposed within compressor outer gerotor chamber 30*o*/30*p*/30*q*. Similarly, expander gerotor apparatus 10*o'*/10*p'*/10*q'* includes an expander outer gerotor 14*o'*/14*p'*/

14q' disposed within housing 12o/12p/12q, an expander outer gerotor chamber 30o'/30p'/30q' at least partially defined by expander outer gerotor 14o'/14p'/14q', and an expander inner gerotor 16o'/16p'/16q' at least partially disposed within expander outer gerotor chamber 30o'/30p'/30q'. Compressor and expander inner gerotors 16o/16p/16q and 16o'/16p'/16q' are rigidly coupled to a shaft 100o/100p/100q that is rotatably coupled to housing 12o/12p/12q by one or more bearings, and compressor and expander outer gerotors 14o/14p/14q and 14o'/14p'/14q' are rigidly coupled to, or integral with, a cylindrical outer gerotor support member 334o/334p/334q that is rotatably coupled to housing 12o/12p/12q by one or more ring-shaped bearings 340o/340p/340q.

As discussed above, unlike engine system 300m shown in FIG. 18, engine systems 300o/300p/300q shown in FIGS. 20-22 output power to an external drive shaft 270o/270p/270q rather than to internal shaft 100o/100p/100q. In general, each engine system 300o/300p/300q includes a rotatable shaft 270o/270p/270q coupled to the rigidly coupled outer gerotors 14o/14p/14q and 14o'/14p'/14q' by a coupling system 272o/272p/272q such that rotation of outer gerotors 14o/14p/14q and 14o'/14p'/14q' causes rotation of shaft 270o/270p/270q and/or vice-versa, as described below.

First, in the embodiment shown in FIG. 20, coupling system 272o includes a first gear 274o interacting with a second gear 276o. First gear 274o is rigidly coupled to cylindrical outer gerotor support member 334o rigidly coupled to outer gerotors 14o and 14o'. Second gear 276o is rigidly coupled to rotatable drive shaft 270o.

Thus, power generated by engine system 300o is withdrawn from first gear 274o mounted to outer gerotors 14o and 14o' and transferred to drive shaft 270o. One advantage of this embodiment is that torque is transmitted directly from outer gerotors 14o and 14o' to drive shaft 270o without involving inner gerotors 16o or 16o', thereby reducing friction and wear at the low-friction regions 140o of compressor outer gerotor 14o and/or inner gerotor 16o, such as low-friction regions 140o at each tip 160o of compressor inner gerotor 16o and proximate the inner perimeter of compressor outer gerotor 14o. At a steady rotational speed, there is negligible torque transmitted through the low-friction regions 140o at tips 160o of compressor inner gerotor 16o and proximate the inner perimeter of compressor outer gerotor 14o because there is little net torque acting on inner gerotors 16o or 16o'. The pressure forces acting on inner gerotors 16o or 16o' that would cause inner gerotors 16o and 16o' to rotate clockwise are substantially counterbalanced by the pressure forces acting to rotate inner gerotors 16o and 16o' counterclockwise. In essence, inner gerotors 16o and 16o' act as an idler.

It should be noted that lubrication channels are omitted to simplify FIG. 20. In practice, lubricant could be supplied to the low-friction regions 140o, such as described herein regarding other embodiments. In addition, as with various other engine systems 300 shown and described herein, in some embodiments, the same mechanical arrangement of engine system 300o could be used in a reverse-Brayton cycle heat pump in which power is input to shaft 270o.

Second, in the embodiment shown in FIG. 21, coupling system 272p includes a first coupler 360p interacting with a second coupler 362p. First coupler 360p is rigidly coupled to cylindrical outer gerotor support member 334p rigidly coupled to outer gerotors 14p and 14p'. Second coupler 362p is rigidly coupled to rotatable drive shaft 270p. A flexible coupling device 364p, such as a chain or belt, couples first coupler 360p and second coupler 362p such that rotation of outer gerotor support member 334p causes rotation of drive shaft 270p, and vice versa.

Thus, power generated by engine system 300p is withdrawn from first coupler 360p mounted to outer gerotors 14p and 14p' and transferred to drive shaft 270p. As discussed above, one advantage of such embodiment is that torque is transmitted directly from outer gerotors 14p and 14p' to drive shaft 270p without involving inner gerotors 16p or 16p', thereby reducing friction and wear at the low-friction regions 140p of compressor outer gerotor 14p and/or inner gerotor 16p. Also, at a steady rotational speed, there is negligible torque transmitted through the low-friction regions 140p at tips 160p, as inner gerotors 16p and 16p' essentially act as an idler.

Again, it should be noted that lubrication channels are omitted to simplify FIG. 21. In practice, lubricant could be supplied to the low-friction regions 140p, such as described herein regarding other embodiments. In addition, as with various other engine systems 300 shown and described herein, in some embodiments, the same mechanical arrangement of engine system 300p could be used in a reverse-Brayton cycle heat pump in which power is input to shaft 270p.

Third, in the embodiment shown in FIG. 22, coupling system 272q includes a first gear 274q interacting with a second gear 276q. First gear 274q is a bevel gear rigidly coupled to cylindrical outer gerotor support member 334q rigidly coupled to outer gerotors 14q and 14q'. Second gear 276q is a bevel gear rigidly coupled to rotatable drive shaft 270q, which is oriented generally perpendicular to shaft 100q. Thus, power generated by engine system 300q is withdrawn from first bevel gear 274q mounted to outer gerotors 14q and 14q' and transferred to drive shaft 270q. As discussed above, one advantage of such embodiment is that torque is transmitted directly from outer gerotors 14q and 14q' to drive shaft 270q without involving inner gerotors 16q or 16q', thereby reducing friction and wear at the low-friction regions 140q of compressor outer gerotor 14q and/or inner gerotor 16q. Also, at a steady rotational speed, there is negligible torque transmitted through the low-friction regions 140q at tips 160q, as inner gerotors 16q and 16q' essentially act as an idler.

Again, it should be noted that lubrication channels are omitted to simplify FIG. 22. In practice, lubricant could be supplied to the low-friction regions 140q, such as described herein regarding other embodiments. In addition, as with various other engine systems 300 shown and described herein, in some embodiments, the same mechanical arrangement of engine system 300q could be used in a reverse-Brayton cycle heat pump in which power is input to shaft 270q.

FIG. 23 illustrates an example cross-section of an engine system 300r in accordance with another embodiment of the invention. Engine system 300r is substantially similar to engine system 300q shown in FIG. 22, except that engine system 300r includes a motor 260r or a generator 264r integrated with the engine, as discussed in greater detail below.

Like engine system 300q shown in FIG. 22, engine system 300r includes a housing 12r, a compressor gerotor apparatus 10r and an expander gerotor apparatus 10r'. Compressor gerotor apparatus 10r includes a compressor outer gerotor 14r disposed within housing 12r, a compressor outer gerotor chamber 30r at least partially defined by compressor outer gerotor 14r, and a compressor inner gerotor 16r at least partially disposed within compressor outer gerotor chamber 30r. Similarly, expander gerotor apparatus 10r' includes an expander outer gerotor 14r' disposed within housing 12r, an expander outer gerotor chamber 30r' at least partially defined by expander outer gerotor 14r', and an expander inner gerotor

16r' at least partially disposed within expander outer gerotor chamber 30r'. Compressor and expander inner gerotors 16r and 16r' are rigidly coupled to a shaft 100r that is rotatably coupled to housing 12r by one or more bearings, and compressor and expander outer gerotors 14r and 14r' are rigidly coupled to, or integral with, a cylindrical outer gerotor support member 334r that is rotatably coupled to housing 12r by one or more ring-shaped bearings 340r.

In addition, like face-breathing engine system 300q shown in FIG. 22, face-breathing engine system 300r shown in FIG. 23 breathes through a first face 252r and a second face 254r of system 300r. In addition, compressor gerotor apparatus 10r and/or expander gerotor apparatus 10r' of engine system 300r shown in FIG. 23 may be self-synchronizing, such as described above regarding the various gerotor apparatuses shown in FIGS. 7-22. Instead or in addition, compressor gerotor apparatus 10r and/or expander gerotor apparatus 10r' may include a synchronizing system 18, such as discussed above regarding FIGS. 1-6, for example. Also, although not shown in order to simplify FIG. 23, engine system 300q may include a lubricant communicated through lubricant channels to provide lubrication between compressor inner gerotor 16r and compressor outer gerotor 14r. Further, like engine system 300q shown in FIG. 22, engine system 300r shown in FIG. 23 outputs power to an external rotatable drive shaft 270r oriented generally perpendicular to shaft 100r and coupled to outer gerotors 14r and 14r' by a coupling system 272r including a first gear 274r interacting with a second gear 276r.

As discussed above, engine system 300r includes a motor 260r or a generator 264r integrated with the engine. As shown in FIG. 23, motor 260r or generator 264r may be coupled to, or integrated with, housing 12r. In embodiments including a motor 260r, motor 260r may drive engine system 300r by driving rigidly coupled, or integrated, outer gerotors 14r and 14r', which may in turn drive inner gerotors 16r and 16r'. For example, motor 260r may drive one or more magnetic elements 262r coupled to, or integrated with, an outer perimeter surface 370r of outer gerotor 14r (or, in an alternative embodiment, an outer perimeter surface of outer gerotor 14r'). A portion of the power generated by motor 260r may be transferred to drive shaft 270r. In some applications, motor 260r may be used as a starter, or it may be used to provide supplemental torque in applications such as hybrid electric vehicles.

In embodiments including a generator 264r, generator 264r may be powered by the rotation of outer gerotors 14r and 14r'. Thus, rotation of outer gerotors 14r and 14r' may supply output power to both generator 264r and drive shaft 270r, which output power may be used for any suitable purpose. Motor 260r/generator 264r may comprise any suitable type of motor or generator, such as a permanent magnet motor or generator, a switched reluctance motor (SRM) or generator, or an inductance motor or generator, for example.

FIG. 24 illustrates an example cross-section of an engine system 300s in accordance with another embodiment of the invention. Engine system 300s is substantially similar to engine system 300r shown in FIG. 23, except that engine system 300s does not include an external drive shaft 270, and thus all the engine power output may be transferred to a generator 264s (or where engine system 300s includes a motor 260s, all the power generated by motor 260s may be used by engine system 300s), as discussed in greater detail below. Because there is no shaft output or input, the system is best viewed as a reverse Brayton cycle heat pump rather than an engine.

Like engine system 300r shown in FIG. 23, engine system 300s includes a housing 12s, a compressor gerotor apparatus

10s and an expander gerotor apparatus 10s'. Compressor gerotor apparatus 10s includes a compressor outer gerotor 14s disposed within housing 12s, a compressor outer gerotor chamber 30s at least partially defined by compressor outer gerotor 14s, and a compressor inner gerotor 16s at least partially disposed within compressor outer gerotor chamber 30s. Similarly, expander gerotor apparatus 10s' includes an expander outer gerotor 14s' disposed within housing 12s, an expander outer gerotor chamber 30s' at least partially defined by expander outer gerotor 14s', and an expander inner gerotor 16s' at least partially disposed within expander outer gerotor chamber 30s'. Compressor and expander inner gerotors 16s and 16s' are rigidly coupled to a shaft 100s that is rotatably coupled to housing 12s by one or more bearings, and compressor and expander outer gerotors 14s and 14s' are rigidly coupled to, or integral with, a cylindrical outer gerotor support member 334s that is rotatably coupled to housing 12s by one or more ring-shaped bearings 340s. In addition, like engine system 300r shown in FIG. 22, engine system 300s shown in FIG. 23 is a face-breathing system, may be self-synchronizing, and may use lubricant (not shown) to provide lubrication between compressor inner gerotor 16s and compressor outer gerotor 14s.

As discussed above, engine system 300s includes an integrated motor 260s or generator 264s, which may be coupled to, or integrated with, housing 12s. In embodiments including a motor 260s, motor 260s may drive engine system 300s by driving rigidly coupled, or integrated, outer gerotors 14s and 14s', which may in turn drive inner gerotors 16s and 16s'. For example, motor 260s may drive one or more magnetic elements 262s coupled to, or integrated with, an outer perimeter surface 370s of outer gerotor 14s (or, in an alternative embodiment, an outer perimeter surface of outer gerotor 14s'). For example, during starting, all of the power generated by motor 260s may be used by engine system 300s. Once the engine has started, there is no way to take energy out of the system. Again, in the case of an electric motor, the compressor/expander system is best viewed as a reverse Brayton cycle heat pump. In embodiments including a generator 264s, all of the engine power output generated by the rotation of outer gerotors 14s and 14s' may be used by generator 264s to make electricity. Motor 260s/generator 264s may comprise any suitable type of motor or generator, such as a permanent magnet motor or generator, a switched reluctance motor (SRM) or generator, or an inductance motor or generator, for example.

FIG. 25 illustrates an example cross-section of an engine system 300t in accordance with another embodiment of the invention. Engine system 300t is substantially similar to side-breathing engine system 300j shown in FIGS. 14-15, except that engine system 300t includes a motor 260t or a generator 264t integrated with the engine, as discussed in greater detail below.

Like engine system 300j, engine system 300t includes a housing 12t, a compressor gerotor apparatus 10t and an expander gerotor apparatus 10t'. Compressor gerotor apparatus 10t includes a compressor outer gerotor 14t disposed within housing 12t, a compressor outer gerotor chamber 30t at least partially defined by compressor outer gerotor 14t, and a compressor inner gerotor 16t at least partially disposed within compressor outer gerotor chamber 30t. Similarly, expander gerotor apparatus 10t' includes an expander outer gerotor 14t' disposed within housing 12t, an expander outer gerotor chamber 30t' at least partially defined by expander outer gerotor 14t', and an expander inner gerotor 16t' at least partially disposed within expander outer gerotor chamber 30t'.

Compressor outer gerotor **14t** may be rigidly coupled to, or integral with, expander outer gerotor **14t'**. Similarly, compressor inner gerotor **16t** may be rigidly coupled to, or integral with, expander inner gerotor **16t'**. Compressor and expander outer gerotors **14t** and **14t'** and compressor and expander inner gerotors **16t** and **16t'** may be rotatably coupled to a single shaft **100t** rigidly coupled to housing **12t**. In the embodiment shown in FIG. 25, compressor and expander outer gerotors **14t** and **14t'** are rotatably coupled to first portions **102t** of shaft **100t** having a first axis about which outer gerotors **14t** and **14t'** rotate, and compressor and expander inner gerotors **16t** and **16t'** are rotatably coupled to a second portion **104t** of shaft **100t** having a second axis about which inner gerotors **16t** and **16t'** rotate, the second axis being offset from the first axis. In addition, a drive shaft **270t** is rigidly coupled to outer gerotors **14t** and **14t'** by a first cylindrical extension **380t**, and rotatably coupled to housing **12t** by one or more bearings **52t**.

Compressor gerotor apparatus **10t** and/or expander gerotor apparatus **10t'** may be self-synchronizing, such as described above regarding the various gerotor apparatuses shown in FIGS. 7-24. Instead or in addition, compressor gerotor apparatus **10t** and/or expander gerotor apparatus **10t'** may include a synchronizing system **18**, such as discussed above regarding FIGS. 1-6, for example. In the embodiment shown in FIG. 25, compressor gerotor apparatus **10t** performs the synchronization function for both compressor gerotor apparatus **10t** and expander gerotor apparatus **10t'**, such as discussed above regarding FIGS. 14-24. In addition, a lubricant **60t** may be communicated through lubricant channels **152t** and **154t** to provide lubrication between compressor inner gerotor **16t** and compressor outer gerotor **14t**.

Engine system **300t** shown in FIG. 25 is a side-breathing system in which fluid flows through sides **306t** and **308t** (rather than the faces) of compressor gerotor apparatus **10t** and expander gerotor apparatus **10t'**, such as described above regarding engine system **300j** shown in FIGS. 14-15. Thus, regarding compressor gerotor apparatus **10t**, fluid may flow from a first fluid inlet **310t**, formed in a first side **314t** of housing **12t**, into compressor outer gerotor chamber **30t** through compressor gerotor openings **324t** formed in the outer perimeter of compressor outer gerotor **14t**, through compressor outer gerotor chamber **30t**, and into first fluid outlet **316t** formed in a second side **320t** of housing **12t** through compressor gerotor openings **324t**. Similarly, regarding expander gerotor apparatus **10t'**, fluid may flow from a second fluid inlet **312t**, formed in first side **314t** of housing **12t**, into expander outer gerotor chamber **30t'** through expander gerotor openings **326t** formed in the outer perimeter of expander outer gerotor **14t'**, through expander outer gerotor chamber **30t'**, and into second fluid outlet **318t** formed in second side **320t** of housing **12t** through expander gerotor openings **326t**.

As discussed above, engine system **300t** includes a motor **260t** or a generator **264t** integrated with the engine. As shown in FIG. 25, motor **260t** or generator **264t** may be coupled to, or integrated with, housing **12t**. In embodiments including a motor **260t**, motor **260t** may drive engine system **300t** by driving rigidly coupled, or integrated, outer gerotors **14t** and **14t'**, which may in turn drive inner gerotors **16t** and **16t'**. For example, motor **260t** may drive one or more magnetic elements **262t** rigidly coupled to, or integrated with, outer gerotors **14t** and **14t'** by a second cylindrical extension **382t**. For example, magnetic elements **262t** may include a series of bar magnets arranged in a circular pattern along the periphery of a disc. A portion of the power generated by motor **260t** may be transferred to drive shaft **270t**. In some applications, motor

260t may be used as a starter, or it may be used to provide supplemental torque in applications such as hybrid electric vehicles.

In embodiments including a generator **264t**, generator **264t** may be powered by the rotation of outer gerotors **14t** and **14t'**. Thus, rotation of outer gerotors **14t** and **14t'** may supply output power to both generator **264t** and drive shaft **270t**, which output power may be used for any suitable purpose. Motor **260t**/generator **264t** may comprise any suitable type of motor or generator, such as a permanent magnet motor or generator, a switched reluctance motor (SRM) or generator, or an inductance motor or generator, for example.

FIG. 26 illustrates an example cross-section of a compressor-expander system **300u** in accordance with another embodiment of the invention. Compressor-expander system **300u** is substantially similar to engine system **300t** shown in FIG. 25, except that compressor-expander system **300u** does not include an external drive shaft **270**, and thus all the power output may be transferred to a generator **264u** (or where compressor-expander system **300u** includes an electric motor **260u**, all the power generated by motor **260u** may be used by compressor-expander system **300u**), as discussed in greater detail below.

Like engine system **300t**, compressor-expander system **300u** includes a housing **12u**, a compressor gerotor apparatus **10u** and an expander gerotor apparatus **10u'**. Compressor gerotor apparatus **10u** includes a compressor outer gerotor **14u** disposed within housing **12u**, a compressor outer gerotor chamber **30u** at least partially defined by compressor outer gerotor **14u**, and a compressor inner gerotor **16u** at least partially disposed within compressor outer gerotor chamber **30u**. Similarly, expander gerotor apparatus **10u'** includes an expander outer gerotor **14u'** disposed within housing **12u**, an expander outer gerotor chamber **30u'** at least partially defined by expander outer gerotor **14u'**, and an expander inner gerotor **16u'** at least partially disposed within expander outer gerotor chamber **30u'**.

Compressor and expander outer gerotors **14u** and **14u'** are rotatably coupled to first portions **102u** of shaft **100u** having a first axis about which outer gerotors **14u** and **14u'** rotate, and compressor and expander inner gerotors **16u** and **16u'** are rotatably coupled to a second portion **104u** of shaft **100u** having a second axis about which inner gerotors **16u** and **16u'** rotate, the second axis being offset from the first axis. Compressor gerotor apparatus **10u** and/or expander gerotor apparatus **10u'** may be self-synchronizing, such as described above regarding the various gerotor apparatuses shown in FIGS. 7-25, and a lubricant **60u** may be communicated through lubricant channels to provide lubrication between compressor inner gerotor **16u** and compressor outer gerotor **14u**. Instead or in addition, compressor gerotor apparatus **10u** and/or expander gerotor apparatus **10u'** may include a synchronizing system **18**, such as discussed above regarding FIGS. 1-6, for example. In addition, compressor-expander system **300u** shown in FIG. 26 is a side-breathing system in which fluid flows through sides **306u** and **308u** (rather than the faces) of compressor gerotor apparatus **10u** and expander gerotor apparatus **10u'**, such as described above regarding engine system **300t** shown in FIG. 25.

As discussed above, compressor-expander system **300u** includes a motor **260u** or a generator **264u** integrated with the engine. As shown in FIG. 26, motor **260u** or generator **264u** may be coupled to, or integrated with, housing **12u**. In embodiments or situations in which electricity is supplied to compressor-expander system **300u**, motor **260u**/generator **264u** functions as a motor **260u**, which may drive rigidly coupled, or integrated, outer gerotors **14u** and **14u'**, which

29

may in turn drive inner gerotors **16u** and **16u'**. For example, motor **260u** may drive one or more magnetic elements **262u** rigidly coupled to, or integrated with, outer gerotors **14u** and **14u'** by a cylindrical extension **382u**. In such situations, compressor-expander system **300u** may function as a reverse Brayton-cycle cooling system, such as for use in an air conditioner, for example.

In embodiments or situations in which fuel is supplied to compressor-expander system **300u** to rotate outer gerotors **14u** and **14u'**, motor **260u**/generator **264u** functions as an electric generator **264u** to produce electricity. In such situations, compressor-expander system **300u** may function as an engine. Motor **260u**/generator **264u** may comprise any suitable type of motor or generator, such as a permanent magnet motor or generator, a switched reluctance motor (SRM) or generator, or an inductance motor or generator, for example.

FIG. 27 illustrates an example cross-section of a gerotor apparatus **10v** having a sealing system **400v** to reduce fluid (e.g., gas) leakage in accordance with one embodiment of the invention. Gerotor apparatus **10v** is substantially similar to gerotor apparatus **10e** shown in FIG. 7, except that gerotor apparatus **10v** includes a sealing system **400v** to reduce fluid (e.g., gas) leakage from outer gerotor chamber **30v**, as discussed in greater detail below.

Like gerotor apparatus **10e** shown in FIG. 7, gerotor apparatus **10v** shown in FIG. 27 includes a housing **12v**, an outer gerotor **14v** disposed within housing **12v**, an outer gerotor chamber **30v** at least partially defined by outer gerotor **14v**, and an inner gerotor **16v** at least partially disposed within outer gerotor chamber **30v**. Outer gerotor **14v** and inner gerotor **16v** are rotatably coupled to a single shaft **100v** rigidly coupled to housing **12v**. In particular, outer gerotor **14v** is rotatably coupled to a first portion **102v** of shaft **100v** having a first axis about which outer gerotor **14v** rotates, and inner gerotor **16v** is rotatably coupled to a second portion **104v** of shaft **100v** having a second axis about which inner gerotor **16v** rotates, the second axis being offset from the first axis.

Housing **12v** includes a valve plate **40v** including one or more fluid inlets **42v** and one or more fluid outlets **44v**. Fluid inlets **42v** generally allow fluids, such as gasses, liquids, or liquid-gas mixtures, to enter outer gerotor chamber **30v**. Likewise, fluid outlets **44v** generally allow fluids within outer gerotor chamber **30v** to exit from outer gerotor chamber **30v**. Gerotor apparatus **10v** may be self-synchronized by one or more low-friction regions **140v**, such as described above regarding the various gerotor apparatuses shown in FIGS. 7-26. Instead or in addition, gerotor apparatus **10v** may include a synchronizing system **18**, such as discussed above regarding FIGS. 1-6, for example. In addition, a lubricant **60v** may be communicated through lubricant channels to provide lubrication between compressor inner gerotor **16v** and compressor outer gerotor **14v**.

As discussed above, gerotor apparatus **10v** includes a sealing system **400v** to reduce leakage of fluid traveling through outer gerotor chamber **30v**. For example, sealing system **400v** may reduce leakage of gas between rotating gerotors **14v** and **16v** and housing **12v**. As shown in the enlarged view of sealing system **400v** in FIG. 27, sealing system **400v** may include soft material **402v** (such as a polymer, for example) and one or more seal protrusions **404v** that form seal tracks **406v** in the soft material **402v**. A substantial seal may be provided between the seal protrusions **404v** and seal tracks **406v**. Seal protrusions **404v** may be formed from a relatively hard material, such as metal, for example. In the embodiment shown in FIG. 27, seal protrusions **404v** comprise hard "blades" that cut into the soft material **402v**. The blades may be circular and may be coupled to, and extend around the

30

circumference of, outer gerotor **14v**. As gerotors **14v** and **16v** deform due to thermal expansion and centrifugal force, the blades **404v** may cut into soft material **402v** to form seal tracks **406v**, thus providing a customized fit. In some embodiments, the surface of blades **404v** may be roughened (e.g., by sand blasting) to help cut soft material **402v**.

FIG. 28 illustrates example cross-sections of three alternative embodiments of a sealing system **400w** similar to sealing system **400v** shown in FIG. 27. In particular, FIG. 28 illustrates three embodiments for forming abraded seals between an outer gerotor **14w** (or an inner gerotor **16w**) and a housing **12w**. As shown in FIG. 28, embodiment (a), a surface **420w** of outer gerotor **14w** is roughened by sandblasting or other suitable means. A layer or surface coating of soft material **402w** is formed on a surface **424w** of housing **12w**. The soft material **402w** may be an abradable material, such as Teflon. When roughened surface **420w** and the abradable material **402w** contact each other, roughened surface **420w** removes a portion of the abradable material **402w**, thus forming a very tight clearance with very low leakage. Although the illustration of embodiment (a) shows flat surfaces being sealed in this manner, these materials and techniques could also be used on curved surfaces.

FIG. 28, embodiment (b) shows a similar sealing system **400w** as embodiment (a), except surface **420w** of outer gerotor **14w** has numerous indentations or holes **428w**, such as formed by a drill, rather than being roughened. Alternatively, surface **420w** may have non-circular holes shaped in a honeycomb or other suitable pattern. The purpose of the indentation or hole **428w** is to accommodate fine dust that is produced when surface **420w** and abradable material **402w** contact each other, as well as to add cutting edges to aid the abrasion process. FIG. 28, embodiment (c) shows a sealing system **400w** that is a combination of embodiments (a) and (b). Surface **420w** of outer gerotor **14w** is both roughened and includes indentations or holes **428w**.

FIG. 29 illustrates a method of forming a sealing system **400x** in accordance with one embodiment of the invention. The method may be used to form a labyrinthian seal between two flat surfaces of a gerotor apparatus, one stationary and the other rotating about a fixed center. For example, as discussed below, the method may be used to form a labyrinthian seal between a surface **420x** of an outer gerotor **14x** (or an inner gerotor **16x**) rotating about a fixed center and a surface **424x** of a stationary housing **12x**.

FIG. 29, view (a) shows a top view of a ring-shaped portion of a housing **12x**, including a ring-shaped sealing portion **432x**. FIG. 29, view (b) shows a partial side view of the ring-shaped portion of housing **12x** as well as a portion of an outer gerotor **14x**. Ring-shaped sealing portion **432x** may interface with a ring-shaped sealing portion **430x** of outer gerotor **14x**. Sealing portion **430x** of outer gerotor **14x** may be formed from a relatively hard material, such as metal, and may include one or more seal protrusions, or cutters, **434x** extending from a surface **420x** of outer gerotor **14x**. Sealing portion **432x** of housing **12x** may include a ring-shaped sealing member **436x** that is spring loaded by one or more springs **438x**. Springs **438x** may push sealing member **436x** upward such that during assembly and/or operation of the relevant gerotor apparatus, sealing member **436x** is spring-biased against seal cutters **434x** of sealing portion **430x**. Sealing member **436x** may be formed from a soft, or abradable, material such as Teflon, for example.

As outer gerotor **14x** begins to rotate relative to the stationary housing **12x**, seal cutters **434x** abrade one or more ring-shaped seal tracks, or grooves, **440x** into the abradable, spring-loaded sealing member **436x**, thus forming a labyrinthian

31

thian seal extending around the circumference of outer gerotor 14x and housing 12x, such as shown in view (c). Although FIG. 29 shows the abrasable sealing portion 432x loaded using springs 438x, other suitable loading mechanisms may be used, such as gas or hydraulic pressure, for example.

FIG. 30 illustrates an example cross-section of a liquid-processing gerotor apparatus 10y in accordance with one embodiment of the invention. Liquid-processing gerotor apparatus 10y may process liquids, liquid/gas mixtures and/or gasses. Gerotor apparatus 10y may function as a pump, a compressor, or an expander, depending on the embodiment or application.

Gerotor apparatus 10y includes a housing 12y, an outer gerotor 14y disposed within housing 12y, an outer gerotor chamber 30y at least partially defined by outer gerotor 14y, and an inner gerotor 16y at least partially disposed within outer gerotor chamber 30y. Outer gerotor 14y is rigidly coupled to a first shaft 50y, which is rotatably coupled to housing 12y by one or more ring-shaped bearings 52y, and inner gerotor 16y is rotatably coupled to a second shaft 54y by one or more ring-shaped bearings 56y, which shaft 54y is rigidly coupled to, or integral with, housing 12y. Outer gerotor 14y rotates about a first axis and inner gerotor 16y rotates about a second axis offset from the first axis. In situations in which gerotor apparatus 10y functions as a pump, power is delivered to gerotor apparatus 10y through first shaft 50y. In situations in which gerotor apparatus 10y functions as an expander, power is output to first shaft 50y.

Housing 12y includes a valve plate 40y that includes one or more fluid inlets 42y and one or more fluid outlets 44y. Fluid inlets 42y generally allow fluids to enter outer gerotor chamber 30y. Likewise, fluid outlets 44y and check valves 230y (if present) generally allow fluids to exit outer gerotor chamber 30y. Fluid inlets 42y and fluid outlets 44y may have any suitable shape and size. Where apparatus 10y is used as a liquid pump, such as a water pump for example, the total area of fluid inlets 42y may be approximately equal to the total area of fluid outlets 44y. Where apparatus 10y functions as an expander, the total area of fluid inlets 42y may be smaller than the total area of fluid outlets 44y. Where apparatus 10y functions as a compressor, the total area of fluid inlets 42y may be greater than the total area of fluid outlets 44y. In some embodiments, valve plate 40y may also include one or more check valves 230y generally operable to allow fluids to exit from outer gerotor chamber 30y, as discussed below regarding FIG. 32, embodiment (b).

Gerotor apparatus 10y may be self-synchronizing, such as described above regarding the various gerotor apparatuses shown in FIGS. 7-27. In particular, outer gerotor 14y and/or inner gerotor 16y may include one or more low-friction regions 140y operable to reduce friction between outer gerotor 14y and/or inner gerotor 16y, thus synchronizing the relative rotation of outer gerotor 14y and inner gerotor 16y. As discussed above, low-friction regions 140y may extend a slight distance beyond the outer surface 132y of inner gerotor 16y and/or inner surface 130y of outer gerotor 14y such that only the low-friction regions 140y of inner gerotor 16y and/or outer gerotor 14y contact each other. Thus, there may be a narrow gap 144y between the remaining, higher-friction regions 142y of inner gerotor 16y and outer gerotor 14y. In addition, in some embodiments, a lubricant (not shown) may be communicated through various lubricant channels to provide lubrication between inner gerotor 16y and outer gerotor 14y.

As discussed above, low-friction regions 140y may be formed from a polymer (phenolics, nylon, polytetrafluoroethylene, acetyl, polyimide, polysulfone, polyphenylene sul-

32

fide, ultrahigh-molecular-weight polyethylene), graphite, or oil-impregnated sintered bronze, for example. In embodiments in which the fluid flowing through outer gerotor chamber 30y is water (e.g., where gerotor apparatus functions as a water pump), low-friction regions 140y may be formed from VESCONITE.

FIGS. 31A-31D illustrate example cross-sections of liquid-processing gerotor apparatus 10y taken along lines J and K, respectively, shown in FIG. 30, according to various embodiments of the invention. As shown in FIG. 31A, at section J, low-friction regions 140y are formed at each tip 160y of inner gerotor 16y, and around the inner perimeter of outer gerotor 14y defining inner surface 130y of outer gerotor 14y. Remaining portions of inner gerotor 16y and outer gerotor 14y may include higher-friction regions 142y. As shown in FIG. 31A, at section K, all of inner gerotor 16y and outer gerotor 14y may be a higher-friction region 142y. However, as discussed above regarding FIG. 30, a narrow gap 144y may be maintained between higher-friction regions 142y of inner gerotor 16y and outer gerotor 14y.

As shown in FIG. 31B, at section J, low-friction regions 140y are formed at each tip 160y of inner gerotor 16y. Outer gerotor 14y includes a low-friction region 140y proximate each tip 162y of inner surface 130y of outer gerotor 14y. Because a large portion of friction and wear between inner gerotor 16y and outer gerotor 14y occurs at the tips 160y and 162y of inner gerotor 16y and outer gerotor 14y, respectively, limiting low-friction regions 140y to areas near such tips 160y and 162y may reduce costs associated where low-friction materials 134y are relatively expensive and/or provide additional structural integrity where low-friction regions 140y are less durable than higher-friction regions 142y. As shown in FIG. 31B, at section K, all of inner gerotor 16y and outer gerotor 14y may be a higher-friction region 142y. Again, as discussed above, a narrow gap 144y may be maintained between higher-friction region 142y of inner gerotor 16y and outer gerotor 14y.

As shown in FIG. 31C, at section J, the complete cross-section of inner gerotor 16y is a low-friction region 140y, while the complete cross-section of outer gerotor 14y is a higher-friction region 142y. As shown in FIG. 31C, at section K, all of inner gerotor 16y and outer gerotor 14y may be a higher-friction region 142y.

As shown in FIG. 31D, at section J, the complete cross-section of both inner gerotor 16y and outer gerotor 14y is a low-friction region 140y. As shown in FIG. 31D, at section K, all of inner gerotor 16y and outer gerotor 14y may be a higher-friction region 142y.

FIG. 32 illustrates example cross-sections of valve plate 40y of liquid-processing gerotor apparatus 10y shown in FIG. 30 according to two different embodiments of the invention. In embodiment (a), outlet valve plate 40y includes a fluid inlet 42y allowing fluids to enter outer gerotor chamber 30y and a fluid outlet 44y allowing fluids to exit outer gerotor chamber 30y. In this embodiment, which is suitable for non-compressible fluids, such as liquids, the area of fluid inlet 42y is substantially identical to the area of fluid outlet 44y.

In embodiment (b), outlet valve plate 40y includes a fluid inlet 42y allowing fluids to enter outer gerotor chamber 30y, a fluid outlet 44y allowing fluids to exit outer gerotor chamber 30y, and one or more check valves 230y also allowing fluids to exit outer gerotor chamber 30y. In this embodiment, the area of fluid inlet 42y may be substantially identical to the total area of fluid outlet 44y and check valves 230y. This embodiment is suitable for a pump that is pressurizing a mixture of liquid and gas. As the liquid/gas mixture is compressed within outer gerotor chamber 30y, the appropriate

check valves open to discharge the liquid/gas mixture. For example, if the fluid flowing through and exiting outer gerotor chamber 30_y consists only of liquid, all check valves 230_y open. If the fluid flowing through and exiting outer gerotor chamber 30_y contains an intermediate content of gas, a portion of check valves 230_y may open. Check valves 230_y may open and/or close slowly. This is particularly useful for applications that operate at relatively low pressures, such as water-based air conditioning. At low pressure, there is insufficient force available to rapidly move the mass of check valves 230_y.

FIG. 33 illustrates an example cross-section of a liquid-processing gerotor apparatus 10_z in accordance with another embodiment of the invention. Gerotor apparatus 10_z is similar to gerotor apparatus 10_y shown in FIG. 30-32, except that gerotor apparatus 10_z includes an integrated motor 260_z or generator 264_z, as discussed in greater detail below. Liquid-processing gerotor apparatus 10_z may process liquids, liquid/gas mixtures and/or gasses. Gerotor apparatus 10_z may function as a pump, a compressor, or an expander, depending on the embodiment or application.

Gerotor apparatus 10_z includes a housing 12_z, an outer gerotor 14_z disposed within housing 12_z, an outer gerotor chamber 30_z at least partially defined by outer gerotor 14_z, and an inner gerotor 16_z at least partially disposed within outer gerotor chamber 30_z. Outer gerotor 14_z and inner gerotor 16_z are rotatably coupled to a single shaft 100_z rigidly coupled to housing 12_z. In particular, outer gerotor 14_z is rotatably coupled to a first portion 102_z of shaft 100_z having a first axis about which outer gerotor 14_z rotates, and inner gerotor 16_z is rotatably coupled to a second portion 104_z of shaft 100_z having a second axis about which inner gerotor 16_z rotates, the second axis being offset from the first axis.

Housing 12_z includes a valve plate 40_z that includes one or more fluid inlets 42_z, one or more fluid outlets 44_z and/or one or more check valves 230_z. Fluid inlets 42_z generally allow fluids to enter outer gerotor chamber 30_z, and fluid outlets 44_z and/or check valves 230_z generally allow fluids within outer gerotor chamber 30_z to exit from outer gerotor chamber 30_z, such as described above regarding valve plate 40_y shown in FIGS. 30 and 30.

Gerotor apparatus 10_z may be self-synchronizing, such as described above regarding gerotor apparatus 10_y shown in FIGS. 30-32. In particular, outer gerotor 14_z and/or inner gerotor 16_z may include one or more low-friction regions 140_z operable to reduce friction between outer gerotor 14_z and/or inner gerotor 16_z, thus synchronizing the relative rotation of outer gerotor 14_z and inner gerotor 16_z. In addition, in some embodiments, a lubricant (not shown) may be communicated through various lubricant channels to provide lubrication between inner gerotor 16_z and outer gerotor 14_z.

As discussed above, gerotor apparatus 10_z includes an integrated motor 260_z or generator 264_z. As shown in FIG. 33, motor 260_z or generator 264_z may be coupled to, or integrated with, housing 12_z. In embodiments including a motor 260_z, motor 260_z may drive gerotor apparatus 10_z by driving outer gerotor 14_z, which may in turn drive inner gerotor 16_z. For example, motor 260_z may drive one or more magnetic elements 262_z coupled to, or integrated with, an outer perimeter surface 370_z of outer gerotor 14_z. In embodiments including a generator 260_y, rotation of outer gerotor 14_z may provide power to generator 260_y to produce electricity. Motor 260_y or generator 264_y may comprise any suitable type of motor or generator, such as a permanent magnet motor or generator, a switched reluctance motor (SRM) or generator, or an inductance motor or generator, for example.

FIG. 34 illustrates an example cross-section of a dual gerotor apparatus 250A having an integrated motor 260A or gen-

erator 264A according to another embodiment of the invention. Dual gerotor apparatus 250A is similar to gerotor apparatus 250_z shown in FIG. 33, but dual gerotor apparatus 250A includes a pair of face-breathing gerotor apparatuses, rather than a single gerotor apparatus, as discussed below.

As shown in FIG. 34, dual gerotor apparatus 250A includes a housing 12A and an integrated pair of gerotor apparatuses, including a first gerotor apparatus 10A proximate a first face 252A of apparatus 250A and a second gerotor apparatus 10A' proximate a second face 254A of apparatus 250A generally opposite first face 252A. First gerotor apparatus 10A and second gerotor apparatus 10A' may both be compressors, may both be expanders, or may include one expander and one compressor, depending on the particular embodiment or application.

Each of gerotor apparatuses 10A and 10A' may be substantially similar to gerotor apparatus 10_z shown in FIG. 33 and described above. Gerotor apparatus 10A includes an outer gerotor 14A disposed within housing 12A, an outer gerotor chamber 30A at least partially defined by outer gerotor 14A, and an inner gerotor 16A at least partially disposed within outer gerotor chamber 30A. Similarly, gerotor apparatus 10A' includes an outer gerotor 14A' disposed within housing 12A, an outer gerotor chamber 30A' at least partially defined by outer gerotor 14A', and an inner gerotor 16A' at least partially disposed within outer gerotor chamber 30A'.

Outer gerotor 14A' may be rigidly coupled to, or integral with, outer gerotor 14A of gerotor apparatus 10A. Outer gerotors 14A and 14A' and inner gerotors 16A and 16A' are rotatably coupled to a single shaft 100A rigidly coupled to housing 12A. In particular, outer gerotors 14A and 14A' are rotatably coupled to first portions 102A of shaft 100A having a first axis, and inner gerotors 16A and 16A' are rotatably coupled to a second portion 104A of shaft 100A having a second axis offset from the first axis. Housing 12A includes a first valve plate 40A proximate first face 252A of apparatus 250A operable to control the flow of fluids through first gerotor apparatus 10A, and a second valve plate 40A' proximate second face 254A of apparatus 250A operable to control the flow of fluids through second gerotor apparatus 10A', such as described above with reference to FIGS. 12-13, for example. In addition, each of gerotor apparatuses 10A and 10A' may be a self-synchronizing gerotor apparatus similar to gerotor apparatus 10_z shown in FIG. 33 as discussed above.

As discussed above, gerotor apparatus 10A includes an integrated motor 260A or generator 264A. Motor 260A or generator 264A may or may not be coupled to, or integrated with, housing 12A. In embodiments including a motor 260A, motor 260A may drive gerotor apparatus 10A by driving outer gerotors 14A and 14A', which may in turn drive inner gerotors 16A and 16A'. For example, motor 260A may drive one or more magnetic elements 262A coupled to, or integrated with, outer gerotors 14A and 14A'. In embodiments including a generator 260A, rotation of outer gerotors 14A and 14A' may provide power to generator 260A to produce electricity. Motor 260A or generator 264A may comprise any suitable type of motor or generator, such as a permanent magnet motor or generator, a switched reluctance motor (SRM) or generator, or an inductance motor or generator, for example.

FIG. 35A illustrates an example cross-section of a dual gerotor apparatus 250B having an integrated motor 260B or generator 264B according to another embodiment of the invention. Dual gerotor apparatus 250B is similar to gerotor apparatus 250A shown in FIG. 34, except that outer gerotors 14B and 14B' of dual gerotor apparatus 250B are rotatably

coupled to an interior surface of housing 12B, rather than being rotatably coupled to a shaft 100, as discussed below in greater detail.

As shown in FIG. 35A, dual gerotor apparatus 250B includes a housing 12B and an integrated pair of gerotor apparatuses, including a first gerotor apparatus 10B proximate a first face 252B of apparatus 250B and a second gerotor apparatus 10B' proximate a second face 254B of apparatus 250B generally opposite first face 252B. First gerotor apparatus 10B and second gerotor apparatus 10B' may both be compressors, may both be expanders, or may include one expander and one compressor, depending on the particular embodiment or application.

Each of gerotor apparatuses 10B and 10B' may be substantially similar to gerotor apparatus 10z shown in FIG. 33 and described above. Gerotor apparatus 10B includes an outer gerotor 14B disposed within housing 12B, an outer gerotor chamber 30B at least partially defined by outer gerotor 14B, and an inner gerotor 16B at least partially disposed within outer gerotor chamber 30B. Similarly, gerotor apparatus 10B' includes an outer gerotor 14B' disposed within housing 12B, an outer gerotor chamber 30B' at least partially defined by outer gerotor 14B', and an inner gerotor 16B' at least partially disposed within outer gerotor chamber 30B'.

Inner gerotors 16B and 16B' are rotatably coupled to a pair of shaft portions 102B and 104B sharing a first axis such that inner gerotors 16B and 16B' rotate around the first axis. Outer gerotor 14B' may be rigidly coupled to, or integral with, outer gerotor 14B of gerotor apparatus 10B. Outer gerotors 14B and 14B' are rotatably coupled to an interior perimeter surface 450B of housing 12B and rotate around a second axis offset from the first axis. In particular, outer perimeter surfaces 452B of outer gerotors 14B and 14B' rotate within, and at least partially in contact with, interior perimeter surface 450B of housing 12B. Thus, at least portions of outer perimeter surfaces 452B of outer gerotors 14B and 14B' may be low-friction regions 140B in order to reduce friction and wear between outer perimeter surfaces 452B of outer gerotors 14B and 14B' and interior perimeter surface 450B of housing 12B. In addition, outer gerotors 14B and 14B' may be self-synchronized with inner gerotors 16B and 16B', such as described above regarding gerotor apparatus 10z shown in FIG. 33. Thus, in some embodiments, such as shown in FIG. 35A, outer gerotors 14B and 14B' may be completely formed from a low-friction material 134B.

Housing 12B includes a first valve plate 40B proximate first face 252B of apparatus 250B operable to control the flow of fluids through first gerotor apparatus 10B, and a second valve plate 40B' proximate second face 254B of apparatus 250B operable to control the flow of fluids through second gerotor apparatus 10B, such as described above with reference to FIGS. 12-13, for example.

As discussed above, gerotor apparatus 10B includes an integrated motor 260B or generator 264B. Motor 260B or generator 264B may or may not be coupled to, or integrated with, housing 12B. In embodiments including a motor 260B, motor 260B may drive gerotor apparatus 10B by driving outer gerotors 14B and 14B', which may in turn drive inner gerotors 16B and 16B'. For example, motor 260B may drive one or more magnetic elements 262B coupled to, or integrated with, outer gerotors 14B and 14B'. In this embodiment, one or more magnetic elements 262B are coupled to, or integrated with, outer gerotors 14B and 14B'. Magnetic elements 262B may be formed from a low-friction material 134B in order to reduce friction and wear between surfaces of magnetic elements 262B and inner gerotors 16B and 16B'.

In embodiments including a generator 260B, rotation of outer gerotors 14B and 14B' may provide power to generator 260B to produce electricity. Motor 260B or generator 264B may comprise any suitable type of motor or generator, such as a permanent magnet motor or generator, a switched reluctance motor (SRM) or generator, or an inductance motor or generator, for example.

FIG. 35B illustrates an example cross-section of a dual gerotor apparatus 250C having an integrated motor 260C or generator 264C according to another embodiment of the invention. Dual gerotor apparatus 250C is similar to gerotor apparatus 250B shown in FIG. 35A, except that outer gerotors 14C and 14C' of dual gerotor apparatus 250C are rotatably coupled to an interior surface of housing 12C by bearings, rather than direct contact between low-friction regions 140 of outer gerotors 14C and 14C' and the interior surface of housing 12C, as discussed below in greater detail.

As shown in FIG. 35B, dual gerotor apparatus 250C includes a housing 12C and an integrated pair of gerotor apparatuses, including a first gerotor apparatus 10C proximate a first face 252C of apparatus 250C and a second gerotor apparatus 10C' proximate a second face 254C of apparatus 250C generally opposite first face 252C. First gerotor apparatus 10C and second gerotor apparatus 10C' may both be compressors, may both be expanders, or may include one expander and one compressor, depending on the particular embodiment or application.

Gerotor apparatuses 10C and 10C' may be substantially similar to gerotor apparatuses 10B and 10B' shown in FIG. 35A. Gerotor apparatus 10C includes an outer gerotor 14C disposed within housing 12C, an outer gerotor chamber 30C at least partially defined by outer gerotor 14C, and an inner gerotor 16C at least partially disposed within outer gerotor chamber 30C. Similarly, gerotor apparatus 10C' includes an outer gerotor 14C' disposed within housing 12C, an outer gerotor chamber 30C' at least partially defined by outer gerotor 14C', and an inner gerotor 16C' at least partially disposed within outer gerotor chamber 30C'.

Inner gerotors 16C and 16C' are rotatably coupled to a pair of shaft portions 102C and 104C sharing a first axis such that inner gerotors 16C and 16C' rotate around the first axis. Outer gerotor 14C' may be rigidly coupled to, or integral with, outer gerotor 14C of gerotor apparatus 10C. Outer gerotors 14C and 14C' are rotatably coupled to housing 12C by one or more ring-shaped bearings 52C and rotate around a second axis offset from the first axis.

In some embodiments, outer gerotors 14C and 14C' may be self-synchronized with inner gerotors 16C and 16C', such as described above regarding gerotor apparatus 10z shown in FIG. 33. Thus, in some embodiments, although not shown in order to simplify FIG. 35A, outer gerotors 14C and 14C' and/or inner gerotors 16C and 16C' may include low-friction regions 140C to facilitate the synchronization.

As discussed above, gerotor apparatus 10C includes an integrated motor 260C or generator 264C. Motor 260C or generator 264C may or may not be coupled to, or integrated with, housing 12C. In embodiments including a motor 260C, motor 260C may drive gerotor apparatus 10C by driving outer gerotors 14C and 14C', which may in turn drive inner gerotors 16C and 16C'. For example, motor 260C may drive one or more magnetic elements 262C coupled to, or integrated with, outer gerotors 14C and 14C'. In this embodiment, one or more magnetic elements 262C are coupled to, or integrated with, outer gerotors 14C and 14C'. In embodiments including a generator 260C, rotation of outer gerotors 14C and 14C' may provide power to generator 260C to produce electricity. Motor 260C or generator 264C may comprise any suitable

type of motor or generator, such as a permanent magnet motor or generator, a switched reluctance motor (SRM) or generator, or an inductance motor or generator, for example.

FIGS. 36-37 illustrate example cross-sections of dual gerotor apparatuses 250D and 250E according to other embodiments of the invention. Dual gerotor apparatuses 250D/250E are similar to dual gerotor apparatus 250B shown in FIG. 35A, except that dual gerotor apparatuses 250D/250E are powered by a rotatable shaft 270D/270E coupled to outer gerotors 14D/14E and 14D'/14E' of dual gerotor apparatus 250D/250E by a coupling device 272D/272E, rather than by a motor, as discussed below in greater detail.

As shown in FIGS. 36-37, dual gerotor apparatuses 250D/250E include a housing 12D/12E and an integrated pair of gerotor apparatuses, including a first gerotor apparatus 10D/10E and a second gerotor apparatus 10D'/10E'. First gerotor apparatus 10D/10E and second gerotor apparatus 10D'/10E' may both be compressors, may both be expanders, or may include one expander and one compressor, depending on the particular embodiment or application.

Gerotor apparatuses 10D/10E and 10D'/10E' may be substantially similar to gerotor apparatuses 10B and 10B' shown in FIG. 35A. Gerotor apparatus 10D/10E includes an outer gerotor 14D/14E and an inner gerotor 16D/16E, and gerotor apparatus 10D'/10E' includes an outer gerotor 14D'/14E' and an inner gerotor 16D'/16E'. Inner gerotors 16D/16E and 16D'/16E' are rotatably coupled to a pair of shaft portions 102D/102E and 104D/104E sharing a first axis. Outer gerotor 14D/14E' may be rigidly coupled to, or integral with, outer gerotor 14D of gerotor apparatus 10D/10E. Like outer gerotors 14B and 14B' shown in FIG. 35A, outer gerotors 14D/14E and 14D'/14E' shown in FIGS. 36-37 are rotatably coupled to an interior perimeter surface 450D/450E of housing 12D/12E. Thus, all or portions of outer gerotors 14D/14E and 14D'/14E' may be low-friction regions 140D/140E in order to reduce friction and wear between outer perimeter surfaces 452D/452E of outer gerotors 14D/14E and 14D'/14E' and interior perimeter surface 450D/450E of housing 12D/12E. In addition, outer gerotors 14D/14E and 14D'/14E' may be self-synchronized with inner gerotors 16D/16E and 16D'/16E', such as described above regarding gerotor apparatus 10z shown in FIG. 33. Thus, in some embodiments, such as shown in FIGS. 36-37, outer gerotors 14D/14E and 14D'/14E' may be completely formed from a low-friction material 134D/134E.

Dual gerotor apparatuses 250D/250E are powered by a rotatable shaft 270D/270E coupled to outer gerotors 14D/14E and 14D'/14E' of dual gerotor apparatuses 250D/250E, such as described above with reference to FIGS. 20-21, for example. As shown in FIG. 36, rotatable shaft 270D is coupled to the rigidly coupled, or integrated, outer gerotors 14D and 14D' by a coupling system 272D such that rotation of outer gerotors 14D and 14D' causes rotation of shaft 270D and/or vice-versa. Coupling system 272D includes a first gear 274D rigidly coupled to outer gerotors 14D and 14D' and interacting with a second gear 276D rigidly coupled to rotatable drive shaft 270D. As shown in FIG. 37, coupling system 272E includes a first coupler 360E rigidly coupled to outer gerotors 14E and 14E' and interacting with a second coupler 362E rigidly coupled to rotatable drive shaft 270E. A flexible coupling device 364E, such as a chain or belt, couples first coupler 360E and second coupler 362E such that rotation of outer gerotors 14E and 14E' causes rotation of drive shaft 270E, and vice versa.

FIG. 38 illustrates an example cross-section of a face-breathing engine system 300F in accordance with one embodiment of the invention. Engine system 300F includes a

housing 12F, a compressor gerotor apparatus 10F, and an expander gerotor apparatus 10F'. Compressor gerotor apparatus 10F includes a compressor outer gerotor 14F disposed within housing 12F, a compressor outer gerotor chamber 30F at least partially defined by compressor outer gerotor 14F, and a compressor inner gerotor 16F at least partially disposed within compressor outer gerotor chamber 30F. Similarly, expander gerotor apparatus 10F' includes an expander outer gerotor 14F' disposed within housing 12F, an expander outer gerotor chamber 30F' at least partially defined by expander outer gerotor 14F', and an expander inner gerotor 16F' at least partially disposed within expander outer gerotor chamber 30F'.

Compressor outer gerotor 14F may be rigidly coupled to, or integral with, expander outer gerotor 14F'. Similarly, compressor inner gerotor 16F may be rigidly coupled to, or integral with, expander inner gerotor 16F'. Compressor and expander inner gerotors 16F and 16F' may be rigidly coupled to a cylindrical member 278F, which may be rotatably coupled by one or more ring-shaped bearings 52F to a shaft 50F rigidly coupled to housing 12F. Compressor and expander outer gerotors 14F and 14F' may be rigidly coupled to a cylindrical member 279F, which may be rotatably coupled to cylindrical portion 330F of housing 12F by one or more ring-shaped bearings 56F.

Engine system 300F breathes through a first face 252F and second face 254F of system 300F. Housing 12F includes compressor valve portions 40F proximate first face 252F of system 300F and operable to control the flow of fluids through compressor gerotor apparatus 10F, and an expander valve plate 40F' proximate second face 254F of system 300F operable to control the flow of fluids through expander gerotor apparatus 10F'. Compressor valve portions 40F define at least one compressor fluid inlet 42F allowing fluids to enter compressor outer gerotor chamber 30F, and at least one compressor fluid outlet 44F allowing fluids to exit compressor outer gerotor chamber 30F. Housing 12F may include compressor outlet channeling portions 460F and 462F that define fluid passageways 464F and 466F to carry fluids (e.g., compressed gases) away from compressor outer gerotor chamber 30F, as indicated by arrow 470F. Expander valve plate 40F' defines at least one expander fluid inlet 42F' allowing fluids to enter expander outer gerotor chamber 30F', and at least one expander fluid outlet 44F' allowing fluids to exit expander outer gerotor chamber 30F'.

Compressor gerotor apparatus 10F and/or expander gerotor apparatus 10F' of engine system 300F shown in FIG. 16 may be self-synchronizing, such as described above regarding the various gerotor apparatuses discussed herein. Compressor gerotor apparatus 10F of engine system 300F may include one or more low-friction regions 140F operable to perform the synchronization function for both compressor gerotor apparatus 10F and expander gerotor apparatus 10F', such as described above with reference to FIGS. 14-26, for example. In other embodiments, engine system 300F may include a synchronizing system 18F, such as shown in FIGS. 1-6, for example. In addition, although not shown in order to simplify FIG. 38, a lubricant may be communicated through lubricant channels to provide lubrication between compressor inner gerotor 16F and compressor outer gerotor 14F.

Engine system 300F may power a rotatable shaft 270F coupled to outer gerotors 14F and 14F', such as described above with reference to FIGS. 20-21, for example. As shown in FIG. 38, rotatable shaft 270F is coupled outer gerotors 14F and 14F' by a coupling system 272F such that rotation of outer gerotors 14F and 14F' causes rotation of shaft 270F and/or vice-versa. Coupling system 272F includes a first gear 274F

39

rigidly coupled to cylindrical member 279F interacting with a second gear 276F rigidly coupled to rotatable drive shaft 270F, which may be rotatably coupled to housing 12F by one or more ring-shaped bearings 474F. In alternative embodiments, coupling system 272F may include a flexible coupling device, such as a belt or chain.

In this embodiment, all of the bearings included in engine system 300F, including bearings 52F, 56F, and 474F, are located near compressor gerotor apparatus 10F or distanced away from expander gerotor apparatus 10F'. This may be advantageous because compressor gerotor apparatus 10F is generally cooler than expander gerotor apparatus 10F', thus protecting bearings 52F, 56F, and 474F from thermal effects.

FIG. 39 illustrates example cross-sectional views S, T and U of engine system 300F taken along lines S, T and U, respectively, shown in FIG. 38 according to one embodiment of the invention.

View S is a cross-sectional view of expander valve plate 40F', which includes an expander fluid inlet 42F' allowing fluids to enter expander outer gerotor chamber 30F', and an expander fluid outlet 44F' allowing fluids to exit expander outer gerotor chamber 30F'.

View T is a cross-sectional view of expander gerotor apparatus 10F', showing expander outer gerotor 14F', expander inner gerotor 16F', and expander outer gerotor chamber 30F'.

View U is a cross-sectional view taken through a portion 480F of housing 12F, and showing shaft 50F and cylindrical member 278F rigidly coupled to inner gerotors 16F and 16F'.

FIG. 40 illustrates example cross-sectional views V, W and X of engine system 300F taken along lines V, W and X, respectively, shown in FIG. 38 according to one embodiment of the invention.

View V is a cross-sectional view of compressor gerotor apparatus 10F, showing compressor outer gerotor 14F, compressor inner gerotor 16F, and compressor outer gerotor chamber 30F. Compressor inner gerotor 16F includes low-friction regions 140F at each tip 160F, and compressor outer gerotor 14F includes low-friction regions 140F proximate compressor outer gerotor chamber 30F.

View W is a cross-sectional view taken through outer channeling portion 460F of housing 12F, which view indicates compressor fluid inlet 42F and compressor fluid outlet 44F. As shown in view W, the cross-sectional area of compressor fluid inlet 42F is greater than the cross-sectional area and compressor fluid outlet 44F.

View X is a cross-sectional view taken through outer channeling portion 460F of housing 12F, as well as through passageway 464F formed by outer channeling portion 460F. View X indicates compressor fluid inlet 42F, compressor fluid outlet 44F, and passageway 464F. As discussed above, compressor fluid outlet 44F and passageway 464F are operable to carry compressed fluids (e.g., high-pressurized gasses) away from compressor apparatus 10F.

FIG. 41 illustrates example cross-sectional views Y and Z of engine system 300F taken along lines Y and Z, respectively, shown in FIG. 38 according to one embodiment of the invention.

View Y is a cross-sectional view of a spoked-hub member 490F coupling outer gerotors 14F and 14F' to cylindrical member 279F (see also FIG. 38). As discussed above, cylindrical member 279F rotates around channeling portion 462F of housing 12F, which defines fluid passageway 466F. The spoked-hub cross-section of spoked-hub member 490F allows fluids to enter compressor apparatus 10F through compressor fluid inlet 42F.

View Z is a cross-sectional view taken through housing 12F, indicating compressor fluid inlet 42F, cylindrical mem-

40

ber 279F, channeling portion 462F of housing 12F, fluid passageway 466F, first gear 274F and second gear 276F of coupling system 272F, and rotatable drive shaft 270F.

FIG. 42 illustrates an example cross-section of a gerotor apparatus 10G including a synchronizing system 18G in accordance with one embodiment of the invention. Gerotor apparatus 10G includes an outer gerotor 14G, an outer gerotor chamber 30G at least partially defined by outer gerotor 14G, and an inner gerotor 16G at least partially disposed within outer gerotor chamber 30G. Inner gerotor 16G is rigidly coupled to a first shaft 50G, which is rotatably coupled to housing 12G, such that inner gerotor 16G rotates around a first axis. Outer gerotor 14G is rigidly coupled to a second shaft 54G, which is rotatably coupled to housing 12G, such that inner gerotor 16G rotates around a second axis offset from first axis (here, in a direction into or out of the page).

Synchronizing system 18G is coupled to, or integrated with, inner gerotor 16G and outer gerotor 14G. Synchronizing system 18G includes an alignment guide, or track, 500G formed in outer gerotor 14G, and one or more sockets 502G formed in a synchronization disc 503G rigidly coupled to, or integrated with, inner gerotor 16G. Sockets 502G may be located outside the outer perimeter of inner gerotor 16G. One or more spherical balls 504G are socket-mounted within sockets 502G such that they may travel (e.g., roll) along alignment track 500G, which synchronizes the relative rotation of inner gerotor 16G and outer gerotor 14G. If balls 504G are well lubricated, they may rotate, rather than slide, within sockets 502G and alignment track 500G, thus reducing friction and wear. Because balls 504G are constantly being accelerated and decelerated as they move along alignment track 500G, sliding may be reduced and rotation encouraged by making balls 504G as light as reasonably possible. Thus, in some embodiments, balls 504G are ceramic or hollow-metal spheres.

In other embodiments, instead of balls 504G, synchronizing system 18G may include a number of alignment members (such as knobs, rollers or pegs, for example) rigidly coupled to inner gerotor 16G. Like balls 504G, such alignment members may travel within alignment track 500G formed in outer gerotor 14G in order to synchronize the relative rotation of inner gerotor 16G and outer gerotor 14G. In addition, in other embodiments, sockets 502G may be formed in outer gerotor 14G and alignment track 500G may be formed in synchronization disc 503G rigidly coupled to, or integrated with, inner gerotor 16G.

FIG. 43 illustrates a cross-section view of gerotor apparatus 10G taken through line AA shown in FIG. 42. In particular, FIG. 43 shows outer gerotor 14G, inner gerotor 16G, outer gerotor chamber 30G, alignment track 500G formed in outer gerotor 14G, and a number of balls 504G mounted within sockets 502G (see FIG. 42) and traveling along alignment track 500G.

In some embodiments, the shape of alignment track 500G may be defined as described with respect to one or more of FIGS. 88-91 of U.S. patent application Ser. No. 10/359,487, which is herein incorporated by reference, as discussed above. Alignment track 500G may include a number of tips 506G corresponding to the number of tips 162G defined by outer gerotor chamber 30G. Thus, in this embodiment, alignment track 500G includes six tips 506G corresponding with the six tips 162G of outer gerotor chamber 30G. Synchronizing system 18G may include a number of balls 504G corresponding to the number of tips 160G defined by inner gerotor 16G. Thus, in this embodiment, synchronizing system 18G includes five balls 504G corresponding with the five tips 160G of inner gerotor 16G.

41

FIG. 44 illustrates an example cross-section of a gerotor apparatus 10H including a synchronizing system 18H in accordance with one embodiment of the invention. Gerotor apparatus 10H includes an outer gerotor 14H, an outer gerotor chamber 30H at least partially defined by outer gerotor 14H, and an inner gerotor 16H at least partially disposed within outer gerotor chamber 30H. Inner gerotor 16H is rigidly coupled to a first shaft 50H, which is rotatably coupled to housing 12H, such that inner gerotor 16H rotates around a first axis. Outer gerotor 14H is rigidly coupled to a second shaft 54H, which is rotatably coupled to housing 12H, such that inner gerotor 16H rotates around a second axis offset from first axis (here, in a direction into or out of the page).

Synchronizing system 18H is coupled to, or integrated with, inner gerotor 16H and outer gerotor 14H. Synchronizing system 18H includes an outer gerotor alignment guide, or track, 500H formed in outer gerotor 14F, and one or more sockets 502H formed within inner gerotor 16F itself. One or more spherical balls 504H are socket-mounted within sockets 502H such that they may travel (e.g., roll) along alignment track 500H, which synchronizes the relative rotation of inner gerotor 16H and outer gerotor 14H. If balls 504H are well lubricated, they may rotate, rather than slide, within sockets 502H and alignment track 500H, thus reducing friction and wear. Because balls 504H are constantly being accelerated and decelerated as they move along alignment track 500H, sliding may be reduced and rotation encouraged by making balls 504H as light as reasonably possible. Thus, in some embodiments, balls 504H are ceramic or hollow-metal spheres.

In other embodiments, synchronizing system 18H may include a number of alignment members (such as knobs, rollers or pegs, for example) rigidly coupled to inner gerotor 16H instead of balls 504H. Like balls 504H, such alignment members may travel within alignment track 500H formed in outer gerotor 14H in order to synchronize the relative rotation of inner gerotor 16H and outer gerotor 14H. In addition, in other embodiments, sockets 502H may be formed in outer gerotor 14H and alignment track 500H may be formed in inner gerotor 16H.

FIG. 45 illustrates a cross-section view of gerotor apparatus 10H taken through line BB shown in FIG. 44. In particular, FIG. 45 shows outer gerotor 14H, inner gerotor 16H, outer gerotor chamber 30H, alignment track 500H formed in outer gerotor 16H, and a number of balls 504H mounted within sockets 502H (see FIG. 44) and traveling along alignment track 500H.

In some embodiments, the shape of alignment track 500H may be defined as described at least with respect to one or more of FIGS. 88-91 of U.S. patent application Ser. No. 10/359,487, which is herein incorporated by reference, as discussed above. Alignment track 500H may include a number of tips 506H corresponding to the number of tips 162H defined by outer gerotor chamber 30H. Thus, in this embodiment, alignment track 500H includes six tips 506H corresponding with the six tips 162H of outer gerotor chamber 30H. Synchronizing system 18H may include a number of balls 504H corresponding to the number of tips 160H defined by inner gerotor 16H. Thus, in this embodiment, synchronizing system 18H includes five balls 504H corresponding with the five tips 160H of inner gerotor 16H.

Generally, the inner and outer gerotors described above have been based upon a hypocycloid or an epicycloid. These geometric shapes are determined by rolling a small circle inside or outside a large circle. The diameter of the larger circle is an integer number times the diameter of the small circle.

$$D_L = aD_s (a = \text{integer})$$

42

For the hypocycloid and epicycloid, the reference point is located on the outside diameter of the smaller circle

$$r = D_s$$

The reference point traces the hypocycloid shape when the small circle is rotated inside the larger circle and it traces the epicycloid shape when the small circle is rotated outside the larger circle.

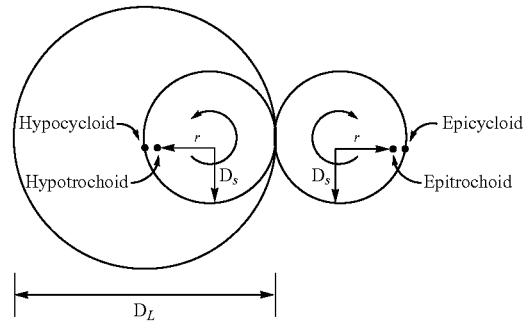

The hypocycloid and epicycloid are special cases of the general cases of hypotrochoids and epitrochoids, respectively. In the general cases, the reference point is located at an arbitrary radius. In one embodiment, for processing fluid, the reference point is at a radius within the smaller circle:

$$r < D_s$$

The hypotrochoids and epitrochoids (and the special cases of hypocycloids and epicycloids) have relatively sharp tips, which may be mechanically fragile. To strengthen the tips, an offset may be added, as shown in the following example:



For an inner gerotor of defined geometry (e.g., hypocycloid, epicycloid, hypotrochoid, epitrochoid) the outer conjugate is the geometry of the outer gerotor. Conceptually, the outer conjugate may be determined by imagining the inner gerotor is mated with a tray of sand. The inner gerotor and tray of sand each spin about their respective centers. The relative spinning rate is determined by the relative number of inner and outer teeth. The outer conjugate is the shape of the remaining sand that is not pushed away. In some cases, the outer conjugate is a well-defined shape with a name (e.g., hypocycloid, epicycloid, hypotrochoid, epitrochoid); in other cases, the outer conjugate does not have a name.

For an outer gerotor of defined geometry (e.g., hypocycloid, epicycloid, hypotrochoid, epitrochoid) the inner conjugate is the geometry of the inner gerotor. Conceptually, the inner conjugate may be determined by imagining the outer gerotor is mated with a tray of sand. The outer gerotor and tray of sand each spin about their respective centers. The relative spinning rate is determined by the relative number of inner and outer teeth. The inner conjugate is the shape of the remaining sand that is not pushed away. In some cases, the inner conjugate is a well-defined shape with a name (e.g., hypocycloid, epicycloid, hypotrochoid, epitrochoid); in other cases, the inner conjugate does not have a name.

The following table shows the combinations of geometries of inner and outer gerotors:

Combination	Inner gerotor	Outer gerotor	Possible?
A	hypocycloid	hypocycloid	yes
B	epicycloid	epicycloid	yes
C	hypocycloid	epicycloid	yes
D	epicycloid	hypocycloid	no
E	hypotrochoid	conjugate	yes
F	conjugate	hypotrochoid	yes
G	epitrochoid	conjugate	yes
H	conjugate	epitrochoid	yes

The following articles, which are herein incorporated by reference, provide detailed methods for defining the geometry of hypocycloids, epicycloids, hypotrochoids, epitrochoids, and conjugates with and without offsets:

Jaroslav Stryczek, *Hydraulic Machines with Cycloidal Gearing*, *Archiwum Budowy Maszyn* (Archive of Mechanical Engineering), Vol. 43, No. 1, pp. 29-72 (1996).

J. B. Shung and G. R. Pennock, *Geometry for Trochoidal-Type Machines with Conjugate Envelopes, Mechanisms and Machine Theory*, Vol. 29, No. 1, pp. 25-42 (1994).

FIGS. 46-49 illustrate a gerotor apparatus 810a according to one embodiment of the invention that is based upon Combination E in the above table, a hypotrochoid inner gerotor 816a and a conjugate outer gerotor 814a. Gerotor apparatus 810a may function both as a compressor or an expander; in the illustrated embodiment, it is assumed to be a compressor. An advantage of Combination E gerotors is that they have very large volumetric capacities, compared to many of the other alternatives. In the example shown in FIGS. 46-49, outer gerotor 814a is disposed within a housing 812a and is rotatable with respect to housing 812a via any suitable manner, such as a shaft 801 and suitable bearings 802. As illustrated best in FIG. 47, outer gerotor 814a includes one tip (sometimes referred to as a "lobe"); however, outer gerotor 814a may include any suitable number of tips. Outer gerotor 814a includes an inlet port 820a that leads to an inner chamber 830a defined by the inside surface of outer gerotor 814a.

As illustrated best in FIG. 48, housing 812a includes a plurality of openings 842a, which may have any suitable size, shape, and orientation. In the illustrated embodiment, openings 842a are vertical slots. Openings 842a allow gas or vapor to enter inner chamber 830a of outer gerotor 814a, as described in further detail below.

Inner gerotor 816a is disposed within inner chamber 830a and is rotatably coupled to a first end 815a of housing 812a via any suitable manner. In the illustrated embodiment, inner gerotor 816a is rotatably coupled to an exit pipe 817a via bearings 803. As illustrated best in FIG. 47, inner gerotor 816a includes two tips 819a (i.e., "lobes"); however, inner gerotor 816a may include any suitable number of tips. In addition, inner gerotor 816a may have any suitable configuration. In the illustrated embodiment, the outside surface of inner gerotor 816a is defined by a hypotrochoid. Inner gerotor 816a also includes a pair of passageways 821a that are each in fluid communication with exit pipe 817a at various times during the rotation of inner gerotor 816a. Passageways 821a may have any suitable size and shape.

Referring mainly to FIG. 47, in operation of one embodiment, both inner gerotor 816a and outer gerotor 814a are spinning clockwise, but outer gerotor 814a is spinning more rapidly (twice as fast in this embodiment). The white dot on inner gerotor 816a is simply a reference point to illustrate the

orientation of inner gerotor 816a during rotation and serves no other function. Gas or vapor enters through inlet port 820a located in outer gerotor 814a. At particular points in the rotation (positions 3 and 7), the captured volume is a maximum. As the rotation continues, the captured volume compresses. Ultimately, the compressed gas travels down through one of the passageways 821a on inner gerotor 816a and into and out of exit pipe 817a. While part of inner chamber 830a is growing and gathering more air, one of the passageways 821a on inner gerotor 816a is blocked so the gas cannot enter it. When part of inner chamber 830a is shrinking and the gas is compressing, one of the passageways 821a on inner gerotor 816a is open allowing the gas to exit.

As best illustrated by FIG. 46, exit pipe 817a includes a projecting portion 823a that projects upward into inner gerotor 816a, thereby blocking one of the passageways 821a at certain times during the rotation of inner gerotor 816a. Projecting portion 823a may have any suitable configuration; however, in the illustrated embodiment, projecting portion 823a is substantially semicircular.

Gerotor apparatus 810a also includes a synchronization system 818a that synchronizes the motion of inner gerotor 816a and outer gerotor 814a. In the illustrated embodiment, as best shown in FIGS. 48 and 49, synchronization system 818a includes an alignment member 828a and an alignment guide 826a. Alignment member 828a may be any suitable alignment member, such as a peg, and alignment guide 826a may be any suitable alignment guide, such as a suitably shaped track. For example, as shown in FIGS. 48 and 49, the track may have a heart shape. Or the track may have a shape configured according to the method outlined in FIG. 2 above. Other suitable synchronization systems are contemplated by the present invention, such as those described in previous disclosures for other embodiments. For example, a gear set may be utilized as well. FIG. 49 illustrates synchronization system 818a in operation of one embodiment of the invention. The black dot on outer gerotor 814a is simply a reference point to illustrate the orientation of outer gerotor 814a during rotation and serves no other function.

FIGS. 50 and 51 illustrate a gerotor apparatus 810b according to another embodiment of the invention, which may only function as a compressor. Gerotor apparatus 810b is substantially similar to gerotor apparatus 810a; however, gerotor apparatus 810b includes an inner gerotor 816b having a plurality of check valves 805 associated with respective ones of passageways 821b to regulate the discharge of gas through passageways 821b of inner gerotor 816b. Check valves 805 may be any suitable check valves and may coupled to passageways 821b in any suitable manner. Because of the existence of check valves 805, exit pipe 817b does not include a projecting portion.

FIG. 52 illustrates a gerotor apparatus 810c according to another embodiment of the invention. Gerotor apparatus 810c is substantially similar to gerotor apparatus 810b; however, rather than employing a synchronizing system, inner gerotor 816c and outer gerotor 814c contact each other. Wear may be minimized by including a lubricant in the gas, as referenced by reference numeral 806, such as is done with vapor-compression air conditioners. Alternatively, the points of contact between inner gerotor 816c and outer gerotor 814c may be made from low-friction materials, such as those described above. In one embodiment, if water is used as a lubricant, a suitable low-friction material may be VESCONITE.

FIGS. 53-55 illustrate a gerotor apparatus 810d according to another embodiment of the invention. Gerotor apparatus 810d is substantially similar to gerotor apparatus 810b; however, for its synchronizing system 818d, gerotor apparatus

810d employs a peg **828d** rigidly attached to outer gerotor **814d**. View M as shown in FIG. **54** illustrates that peg **828d** rides in a linear track **826d** located within inner gerotor **816d**. Both peg **828d** and linear track **826d** may be constructed from any suitable metal. Alternatively, peg **828d** and linear track **826d** may be constructed of low-friction materials, such as those described above. In one embodiment, if water is used as a lubricant, a suitable low-friction material is VESCONITE. Synchronizing system **818d** may also be used in conjunction with any suitable lubricant, such as oil or grease. As yet another alternative, peg **828d** may be constructed of a roller bearing that rolls within linear track **826d**. FIG. **55** illustrates synchronization system **818d** in operation of one embodiment of the invention. The small black dots illustrated are simply reference points to illustrate the orientation of outer gerotor **814d** and inner gerotor **816d** during rotation.

FIGS. **56-59** illustrate a gerotor apparatus **810e** according to another embodiment of the invention. Gerotor apparatus **810e** may function both as a compressor or expander; here, it is assumed to be a compressor. Gerotor apparatus **810e** has a synchronization system **818e** similar to that of gerotor apparatus **810d**; however, the motion of the inner and outer gerotors may be synchronized in other suitable manners. In this embodiment, gerotor apparatus **810e** accounts for the discharge of gas through an outlet port **807** formed in a faceplate **808** of the outer gerotor **814e** rather than through an exit pipe in the center. View N (FIG. **57**) shows a small notch **844** in outer gerotor **814e** through which gas travels through outlet port **807** for exiting through an exhaust port **809** formed in housing **812e**. Notch **844**, outlet port **807** and exhaust port **809** may have any suitable size and shape. View O (FIG. **58**) shows outlet port **807** in sectional view and View P (FIG. **59**) shows exhaust port **809** in sectional view. The position and length of exhaust port **809** determines the compression ratio for gerotor apparatus **810e**. Generally, a longer exhaust port **809** means a lower compression device whereas a shorter exhaust port **809** means a higher compression device. In this embodiment, both inner gerotor **816e** and outer gerotor **814e** may be rotatably coupled to housing **812e** via a shaft **843** that is rigidly coupled to housing **812e**.

FIGS. **60-61** illustrate a gerotor apparatus **810f** according to another embodiment of the invention. Gerotor apparatus **810f** is substantially similar to gerotor apparatus **810e**; however, inlet air enters from an inlet port **845** formed in an endwall **846** of housing **812f** rather than from a sidewall. In other embodiments, air could enter from both endwall **846** and the sidewall of housing **812f**. View II (FIG. **61**) shows a notch **847** that allows air to enter outer gerotor **814f** via an inlet port **848**. View JJ shows inlet port **848** through which the air flows. View KK shows the inlet port **845** in housing **812f**. Notch **847**, inlet port **848** and inlet port **845** may have any suitable size and shape.

FIGS. **62-63** illustrate a gerotor apparatus **810g** according to another embodiment of the invention. Gerotor apparatus **810g** is substantially similar to gerotor apparatus **810f**; however, the discharge is through a hole **849**, rather than a notch. In some embodiments, it is possible that the discharge methods of FIGS. **56** and **62** could be combined, allowing gas to discharge from both the hole and notch. View LL (FIG. **63**) shows that there is no notch and View MM shows hole **849** through which the gas exits. View NN shows an exhaust port **850** in housing **812g**, which functions similarly to exhaust port **809** of FIG. **59**.

FIGS. **64-68** illustrate a gerotor apparatus **810h** according to another embodiment of the invention. In this embodiment, an outer gerotor **814h** is stationary; there is no separate housing. Outer gerotor **814h** includes at least one inlet port **820h**

that leads to an inner chamber **830h** defined by the inside surface of outer gerotor **814h**. A first shaft **851** is rotatably coupled to outer gerotor **814h** and a disk **852** is coupled to first shaft **851**. A second shaft **853** is coupled to disk **852** and is offset from the axis of rotation of first shaft **851**. This arrangement facilitates the rotation and orbiting of an inner gerotor **816h** within inner chamber **830h** because inner gerotor is rotatably coupled to second shaft **853**. As shown best in FIG. **65**, the white dot on inner gerotor **816h** is simply a reference point illustrating the orientation of inner gerotor **816h** during rotation. Also shown in FIG. **65** are the centers of rotation of inner gerotor **816h**.

In operation of this embodiment, gas enters through side port **820h** on outer gerotor **814h** and exits through an outlet port **854** formed in outer gerotor **814h**. Although outlet port **854** may be formed in any suitable location, in the illustrated embodiment, outlet port **854** is located on the opposite side of the tip separates inlet port **820h** from outlet port **854**. The motion of inner gerotor **816h** and outer gerotor **814h** may be synchronized in any suitable manner, such as with a synchronization system **818h** as illustrated in FIG. **68**.

FIGS. **66** and **67** illustrate that gerotor apparatus **810h**, in accordance with another embodiment of the invention, may include a check valve **855** associated with outlet port **854** to regulate the discharge of gas through outlet port **854** of outer gerotor **814h**. In addition, View R of FIG. **67** illustrates that an endwall **857** of outer gerotor **814h** may have an aperture **858** formed therein for an additional gas outlet. Aperture **858** may have an associated check valve **856** to regulate the discharge of gas therethrough. Check valves **855** and **856** may be any suitable check valves and may couple to outlet port **854** and aperture **858** in any suitable manner.

FIG. **69** illustrates a gerotor apparatus **810i** according to another embodiment of the invention. Gerotor apparatus **810i** is substantially similar to gerotor apparatus **810a** (see FIGS. **46-47** above); however, an inner gerotor **816i** of gerotor apparatus **810i** has four tips **819i** and an outer gerotor **814i** has three tips. Inner gerotor **816i** is disposed within inner chamber **830i** and is rotatably coupled to an exit pipe **817i**. In the illustrated embodiment, the outside surface of inner gerotor **816i** is defined by a hypocycloid. Inner gerotor **816i** includes a plurality of passageways **821i** that are each in fluid communication with exit pipe **817i** at various times during the rotation of inner gerotor **816i**. Passageways **821i** may have any suitable size and shape. Exit pipe **817i** includes a projecting portion **823i** that projects upward into inner gerotor **816i**, thereby blocking three of the four passageways **821i** at certain times during the rotation of inner gerotor **816i**. The projecting portion in this embodiment is penannular; however, other configurations are contemplated by the present invention.

FIG. **70** shows a method by which a track may be scribed onto an inner gerotor, such as inner gerotor **816i**. A bar **860** is rigidly attached to an outer gerotor, in this case, outer gerotor **814i**. As the inner and outer gerotors rotate with respect to each other, a point **861** on bar **860** scribes an outline of a track **862** (FIG. **71**) onto inner gerotor **816i**. FIG. **72** shows pegs **863** located on outer gerotor **814i** sliding along track **862**. The side view shown in FIG. **53** illustrates a placement of the pegs **863** and track **862**, as an example. Other suitable synchronization systems are contemplated by the present invention.

FIG. **73** illustrates a gerotor apparatus **810j** according to another embodiment of the invention. Gerotor apparatus **810j** is substantially similar to gerotor apparatus **810i**; however, gerotor apparatus **810j** includes an inner gerotor **816j** having a plurality of check valves **865** associated with respective ones of passageways **821j** to regulate the discharge of gas through passageways **821j** of inner gerotor **816j**. Check

valves **865** may be any suitable check valves and may be coupled to passageways **821j** in any suitable manner. Because of the existence of check valves **865**, the exit pipe (not explicitly shown) does not include a projecting portion.

FIGS. **74** and **75** illustrate a gerotor apparatus **810k** according to another embodiment of the invention. Gerotor apparatus **810k** is substantially similar to gerotor apparatus **810h** (see FIGS. **64** and **65**); however, an inner gerotor **816k** has four tips **819k** and an outer gerotor **814k** has three. FIG. **75** shows a possible valve plate **866** that has any suitable number of check valves **867** that provide an additional means for gas to exit gerotor apparatus **810k**.

FIG. **76** shows a plurality of pegs **868** and a track **869** for gerotor apparatus **810k**. For simplicity purposes, the inlet and outlet ports of outer gerotor **814k** are not explicitly shown. In the illustrated embodiment, the shape of track **869** is a hypocycloid. The outer shape of inner gerotor **816k** may be generated by adding an offset to the hypocycloid.

FIGS. **77-80** illustrate a face-breathing engine system **900a** in accordance with one embodiment of the invention. Engine system **900a** is similar to engine system **300o** shown in FIG. **20** in that power is transmitted from outer gerotors **914a** and **914a'** to an external rotatable shaft **901** via a suitable gear set **902** (see View DD in FIG. **79**). However, engine system **900a** is different because it employs thermal management systems and components, as described below in conjunction with FIGS. **79** and **80**.

Referring to FIG. **78**, View AA shows a compressor valve plate **903**. An inlet port **904** is on the right and a smaller outlet port **905** is on the lower left. A small hole **906** between inlet port **904** and outlet port **905** allows a small portion of partially compressed air to be bled off for cooling purposes for expander section **907a**, as indicated by reference numeral **908**. View BB shows low-friction inserts **909** on the tips of inner compressor gerotor **916a** and along the inner edge of the outer compressor gerotor **914a**. The inserts **909** allow direct contact between inner compressor gerotor **916a** and outer compressor gerotor **914a**, thus synchronizing their rotation. View CC shows lower portions of inner compressor gerotor **916a** and outer compressor gerotor **914a**, where there is no substantial physical contact. Other suitable synchronizing systems may be utilized, such as gears or pegs/cams. Please refer to FIGS. **16-22** above for additional details on compressor section **911a**.

Referring to FIG. **79**, View EE shows a cross-section through a heat sink **918a**, that is coupled between outer compressor gerotor **914a** and outer expander gerotor **914a'**. In some embodiments, heat sink **918a** may include a plurality of fins **919** on the exterior to help dissipate heat. Heat sink **918a** may be constructed of any suitable material, such as a solid metal with a thick cross-section to help transfer heat to fins **919**. Alternatively, heat sink **918a** may be a suitable heat pipe, which is able to transfer heat to fins **919** with great capacity. Also shown in View EE is a perforated housing **912a'** of expander section **907a**.

View FF shows an upper portion **921** of outer expander gerotor **914a'** that couples to heat sink **918a**. Rather than a continuous connection, upper portion **921** is segmented in order to intermittently couple to heat sink **918a** to minimize the cross-sectional area for heat transfer between the hot outer expander gerotor **914a'** and heat sink **918a**. At the center of View FF is a spinning disk **922** having a plurality of secondary passageways **923** formed therein that suck cool air in via a primary passageway **924** of a center shaft **925** in the expander section **907a** via centrifugal force. The spinning disk **922** directs the air toward outer expander gerotor **914a'** during operation of engine system **900a**. View GG (FIG. **80**) shows

an expander seal plate **926** containing small holes **927** that line up with small holes **928** in outer expander gerotor **914a'**.

View HH shows outer expander gerotor **914a'** and inner expander gerotor **916a'**. In the illustrated embodiment, both outer expander gerotor **914a'** and inner expander gerotor **916a'** are formed from a ceramic; however, other suitable materials are also contemplated by the present invention. Inner expander gerotor **916a'** couples to center shaft **925** in a discontinuous manner, such as with splines, thereby minimizing heat transfer from inner expander gerotor **916a'** to center shaft **925**. In addition to small holes **928** of outer expander gerotor **914a'**, inner expander gerotor **916a'** also includes small holes **929** through which cool air flows, allowing temperature regulation of inner expander gerotor **916a'** and outer expander gerotor **914a'**. As described above, the cool air is bled from compressor section **911a** via hole **906**. After the cool air flows through the gerotors and heat sink **918a**, it becomes warm. It may be discharged into the ambient air or, if warm enough, it may be used to preheat the compressed air prior to the combustor. Referring to FIG. **77**, the cool air flowing through the hollow center shaft **925** keeps it cool. Also, fins or a heat pipe may keep the lower bearing cool.

The shut-down procedure for engine system **900a** involves reducing the temperature of the combustor while simultaneously flowing cool air through the inner and outer gerotors of expander section **907a**. As the temperature is reduced, the engine efficiency is reduced, so it may be necessary to remove or reduce the load on the engine. Once the inner and outer gerotors of expander section **907a** are sufficiently cool, then the engine stops.

FIGS. **81-86** illustrate a face-breathing engine system **900b** in accordance with another embodiment of the invention. Engine system **900b** includes a compressor section **911b** at the top and an expander section **907b** at the bottom. View A (FIG. **82**) shows a valve plate **903b** that allows for bleed off of a small amount of air at a pressure intermediate between the inlet and outlet air pressures via a hole **906b**. This bleed air may be used to cool components of expander section **907b**, as discussed in more detail below. View B shows the interaction between an inner compressor gerotor **916b** and outer compressor gerotor **914b**. View C shows a seal plate **930** of compressor section **911b**.

View D (FIG. **83**) shows a synchronization system **917b** for engine system **900b**; however, other suitable synchronization systems are contemplated by the present invention. View D also shows a housing **912b** for compressor section **911b**.

Referring to FIG. **84**, View F shows that an outer housing **912b'** of expander section **907b** is suitably perforated allowing for ambient air to enter housing **912b'**, thereby cooling any metal components of expander section **907b'**. One of these metal components is a heat sink **918b** having optional fins **919b** to facilitate cooling. In another embodiment, the heat sink **918b** may be hollow and contain a suitable phase-change material, such as wax or metal, that is solid while engine system **900b** is operating. When engine system **900b** is shut off, the phase-change material melts and absorbs thermal energy that would transfer from the expander section **907b** to other components, which may be temperature sensitive (e.g., bearings). Alternatively, the hollow section may contain chemicals that participate in a reversible chemical reaction that releases heat at low temperatures and absorbs heat at high temperatures. The need for this hollow section may be eliminated by running engine system **900b** in a cool-down mode prior to shut off. The ceramic components would not be hot enough to damage the sensitive components. Also, liquid water may be sprayed on those components that are temperature sensitive just prior to shut down. View G shows a spring

cup **932** formed from suitable metal coupled to an inside of heat sink **918b**. A ceramic end plate **933** of outer expander gerotor **914b'** is disposed within spring cup **932** and includes a plurality of cooling holes **934** formed therein.

Referring now to FIG. **85**, View H shows inner expander gerotor **916b'** and outer expander gerotor **914b'**, both of which are made of a ceramic. The outer segmented metal ring shown is a lower portion of spring cup **932**. It is segmented to accommodate thermal expansion of outer expander gerotor **914b'**. View I shows a valve plate **935** for the expander section **907b**.

FIG. **86** shows a perspective view of spring cup **932**. The tips of longitudinal fingers **936** of spring cup **932** include radial protrusions **937**, which allows spring cup **932** to lock into a groove **938** of outer expander gerotor **914b'**. (See blown-up detail in FIG. **81**.) This arrangement allows for precise positioning of outer expander gerotor **914b'** without a direct metal/ceramic bond. Further, it accommodates different thermal expansion rates of ceramics and metal.

To allow the ceramic to operate at high temperatures, but prevent damage to the metal components, medium pressure gas may be tapped from compressor section **911b** and blown through holes **940** and **941** in inner expander gerotor **916b'** and outer expander gerotor **914b'**, respectively (see FIG. **85**). Also, to prevent the center shaft **942** from getting too hot, compressor gas that leaks from seal plate **930** (View C of FIG. **82**) will flow down the center of the engine cooling the interior of the inner expander gerotor **816b'** and exiting through a port **943** near the bottom. If necessary, the bearings at the bottom mount into a section of the housing that may have fins or some other heat sink mechanism, to maintain a cool temperature.

FIG. **87(a)** shows an inner gerotor **916c** having a plurality of notches **950** that provide extra area for gases to leave through the exhaust port, allowing for more efficient breathing. FIG. **87** shows the notches on a hypocycloid; however, they may be used on the other suitable geometries, such as epicycloids, hypotrochoids, epitrochoids, and conjugates as well. Similar notches may be used on an outer gerotor. In an embodiment for a gerotor set composed of two epicycloids, the notches **950** would appear on the outer gerotor to accomplish the same benefit. Notches **950** add dead volume, which may adversely affect efficiency; any high-pressure gas trapped in a notch is transported to the intake port and non-productively exhausted. The energy it took to compress that gas is wasted. To overcome this efficiency problem, the shape of the intake port may be adjusted. In one embodiment, notches **950** are wedge-shaped and are shallow at the base and deeper at the top.

FIG. **87(b)** shows a conventional valve plate **951**. The intake section **952** of valve plate **951** is adjacent to the seal section **953**. Any high-pressure gas contained within notches **950** is lost to the intake section **952**. FIG. **87(c)** shows a modified valve plate **951'** that has a smaller intake port **952'**. There is an expansion section **954** between the seal section **953'** and intake section **952'**. Any high-pressure gas trapped in notches **950** expands in expansion section **954**, which applies torque to the gerotors and recovers much of the energy invested in this high-pressure trapped gas.

FIGS. **88-90** illustrate tip-breathing gerotors **960a**, **960b** according to various embodiments of the invention. FIG. **88(a)** shows support rings or strengthening bands **962** that wrap around an outer gerotor **963** that provide support to the wall of outer gerotor **963**. Strengthening bands **962** may be composed of graphite fibers, other high-strength, high-stiffness materials, or other suitable materials. FIG. **88(b)** shows strengthening ligaments **964** that couple between tips of outer

gerotor **965**. FIG. **89(a)** shows that seals **966a** require notches **967** to accommodate strengthening bands **962**. In contrast, FIG. **89(b)** shows the seals **966b** for ligaments **964** do not require notches. The un-notched seal **966b** is preferred because there is no interference due to axial thermal expansion. However, there is more dead volume with the embodiment shown in FIG. **89(b)**.

FIG. **90(a)** shows a conventional sealing system for a tip-breathing gerotor **970a**. Any high-pressure gas trapped in the tips **971a** is transferred to the intake region **972a** without recapturing the energy invested in this high-pressure gas. FIG. **90(b)** shows an improved sealing system for a tip-breathing gerotor **970b** that has an added expansion section **973b** where the high-pressure gas trapped in the dead volume of the tips **971b** has an opportunity to re-expand and impart torque to the gerotors, thereby recovering much of the energy invested in the trapped high-pressure gas.

FIGS. **91-94** illustrate a face-breathing gerotor apparatus **810m** according to one embodiment of the invention that allows for an upper valve plate **840m** and a lower valve plate **841m** at opposite ends thereof. The extra breathing area allows for a longer compressor (or an expander if high-pressure gas enters through the smaller port.)

Referring to FIG. **92**, View A shows upper valve plate **840m**. View B shows an outer gerotor **814m** disposed within a housing **812m**. Outer gerotor **814m** includes a plurality of slots **870m** that allow gases to pass between upper valve plate **840m** and the voids between inner gerotor **816m** and outer gerotor **814m**. Because these slots **870m** add dead volume, upper valve plate **840m** includes an expansion section **871** to extract work from any high-pressure gases trapped in the dead volume.

Referring to FIG. **93**, View C shows a synchronization system **818m** that allows for direct contact between inner gerotor **816m** and outer gerotor **814m** through a low-friction, low-wear material, such as VESCONITE discussed above. Other suitable synchronization systems may be employed. View D shows the interaction of inner gerotor **816m** and outer gerotor **814m**; there is a small gap so these components do not touch.

Referring to FIG. **94**, View E shows slots **873** in the outer gerotor **814m** that allow gases to pass between lower valve plate **841m** and the voids between the inner gerotor **816m** and outer gerotor **814m**. View F shows lower valve plate **841m**.

FIG. **95** shows a synchronization system **818n** composed of an inner gerotor **816n** and an outer gerotor **814n**. Synchronization system **818n** is designed to accommodate thermal expansion of inner gerotor **816n** and outer gerotor **814n** from their respective centers. FIG. **95(a)** shows that a gap **880** opens up at the top tip of inner gerotor **816n**. In addition, there is interference at the bottom tip of inner gerotor **816n**. However, at the left tip of inner gerotor **816n**, the expansion of the inner gerotor **816n** and outer gerotor **814n** is nearly the same from their respective centers. The left tip is the preferred contacting tip for the most precise synchronization. Cutting away material from outer gerotor **814n**, as shown by the dotted line **883** in FIG. **95(a)**, prevents interference of the bottom tip. FIG. **95(b)** shows the final shape of outer gerotor **814n** in which a portion **884** of each tip is removed to allow for thermal expansion.

FIG. **96(a)** shows that a phase-shifted set of tips may be added to an outer gerotor **814o** of a synchronization system **818o**, thereby giving additional contacting surfaces which spread the load over a wider surface area. In the illustrated embodiment, the number of tips are doubled; however, the number of tips may be multiplied by any suitable positive integer greater than one. FIG. **96(b)** shows that a phase-

shifted set of tips may be added to an inner gerotor **8160**. FIG. **96(c)** shows the mated inner gerotor **816o** and outer gerotor **8140**.

FIG. **97(a)** shows that a plurality of tips **885** of an inner synchronization gerotor **816p** may be comprised of full cylinders. Only a portion of the cylinder actually contacts the outer gerotor **814p**. To reduce windage losses, the cylinder may be cut, as in FIG. **97(b)** to produce a half cylinder **886** or some other portion of a cylinder. The cylinder may be mounted to the outer edge of inner gerotor **816p** as shown in FIG. **97(c)** or to a perimeter of inner gerotor **816p** as shown in FIG. **97(d)**.

FIG. **98(a)** shows even more phase-shifted sets of tips **887**, **888** may be added to both the outer gerotor and inner gerotor, respectively. FIG. **98(b)** shows that when the number of phase-shifted sets of tips increases to a very high number, the hypocycloid portions of the outer gerotor become irrelevant; synchronization may occur strictly through male and female semicircular tips. FIG. **98(b)** shows the male tips **889** on the inner gerotor and the female tips **890** on the outer gerotor. FIG. **99** shows that this may be reversed; the male tips may be on the outer gerotor and the female tips on the inner gerotor.

FIGS. **100-103** illustrate a face-breathing gerotor apparatus **810r** according to another embodiment of the invention. Gerotor apparatus **810r** is substantially similar to gerotor apparatus **810m**; however, gerotor apparatus **810r** includes a synchronization system **818r** at the top, so it may breath only from the bottom face. Although illustrated as a compressor, gerotor apparatus **810r** may also serve as an expander. View A (FIG. **101**) shows that synchronization system **818r** is similar to that illustrated in FIG. **99**; however, other suitable synchronization systems are contemplated by the present invention. View B shows a seal plate **892**.

Referring to FIG. **102**, View C shows the interaction of inner gerotor **816r** and outer gerotor **814r**. View D in FIG. **103** shows the slots **894** in outer gerotor **814r** that allows gas passage between a lower valve plate **841r** and the voids between inner gerotor **816r** and outer gerotor **814r**. View E shows lower valve plate **841r**, which is similar to lower valve plate **841m** in FIG. **94**.

FIG. **104** shows a method for obtaining a power boost in a Brayton cycle engine according to one embodiment of the invention. FIG. **104(a)** shows that liquid water **990a** may be added to a combustor **991a** when a power boost is desired. In combustor **991a**, extra fuel may be added to cause the liquid water to vaporize, thereby making steam. The extra volume of high-pressure gas is then sent to an expander **992a**, which generates additional power. If a compressor **993a** and expander **992a** are not rigidly coupled through a common shaft **994a**, the extra power comes in the form of faster rotation of expander **992a**. Alternatively, if the two are rigidly coupled through common shaft **994a**, then the inlet port of expander **992a** may be opened to accommodate the additional volume. In this case, the gas is not fully expanded when it exits expander **992a**, thereby reducing efficiency.

FIG. **104(b)** shows an alternative embodiment for obtaining the power boost. In the embodiment shown in FIG. **104(b)**, the liquid water **990b** is added to a secondary heat exchanger **995b** that has a high thermal capacity. When liquid water is added to heat exchanger **995b**, the thermal capacity of heat exchanger **995b** provides energy to vaporize the liquid water; therefore, steam enters combustor **991b** not liquid water. Eventually, the thermal capacity of heat exchanger **995b** will be exhausted, but by then, the fuel rate may be increased to combustor **991b** to accommodate the extra load.

Below are control schemes that may be implemented for the Brayton cycle engine:

1. Maintain a constant compression ratio, vary combustor temperature. However, this may not be very efficient. At partial load, heat is not being delivered at the maximum temperature allowed by the materials. For a heat engine to be efficient, it may be necessary for the temperature at which heat is added to be as high as possible.

2. Maintain constant compression ratio and maximum combustor temperature. This engine operates at constant torque. Power output may be varied by adjusting engine speed. Increasing the torque requirement of the load slows the engine and decreasing the torque requirement of the load speeds the engine.

3. Vary compression ratio and combustor temperature. At each compression ratio, there is an optimal combustor temperature that prevents over-expansion or under-expansion of the gas exiting the expander.

4. Maintain constant compression ratio and combustor temperature, and throttle the inlet air to the compressor. Adding a restrictor to the inlet of the compressor restricts air flow, as is done in Otto cycle engines. This may be used to regulate power output; however, it is not very efficient because of irreversibilities associated with the pressure drop across the throttle.

For those control schemes above that vary compression ratio, the discharge port of the compressor and inlet port to the expander may need a mechanism that varies the area. Some such mechanisms were described above or in U.S. patent application Ser. No. 10/359,487. If the device has dead volume, and the compression ratio is varied, both inlet and outlet ports of both the compressor and expander should be varied for optimal performance.

Although embodiments of the invention and their advantages are described in detail, a person skilled in the art could make various alterations, additions, and omissions without departing from the spirit and scope of the present invention.

What is claimed is:

1. A gerotor apparatus, comprising:

a housing;

a rotatable outer gerotor disposed at least partially within the housing, the outer gerotor at least partially defining an outer gerotor chamber;

a rotatable inner gerotor disposed at least partially within the outer gerotor chamber;

a seal formed between the housing and at least one of the outer gerotor and the inner gerotor, wherein the seal is configured to restrict passage of fluid between the housing and the at least one of the outer gerotor and the inner gerotor;

a seal portion of the housing; and

one or more seal protrusions coupled to the at least one of the outer gerotor and the inner gerotor, the one or more seal protrusions configured to contact the seal portion.

2. The apparatus of claim 1, wherein the seal comprises a labyrinthian seal.

3. The apparatus of claim 1, wherein:

the seal portion of the housing is formed from a soft material; and

the one or more seal protrusions are formed from a hard material.

4. The apparatus of claim 1, wherein:

the seal portion of the housing is formed from an abradable material;

at least one of the one or more seal protrusions is configured to form one or more seal tracks by abrading into the seal portion of the housing.

53

- 5. The apparatus of claim 4, wherein the at least one of the one or more seal protrusions comprises one or more indentations configured to receive particles produced when the at least one of the one or more seal protrusions abrades the seal portion of the housing.
- 6. The apparatus of claim 1, wherein the seal portion of the housing is spring loaded.
- 7. The apparatus of claim 1, wherein the seal portion of the housing is biased against the one or more seal protrusions.
- 8. A gerotor apparatus, comprising:
 - a housing;
 - an outer gerotor disposed at least partially within the housing, the outer gerotor at least partially defining an outer gerotor chamber;
 - an inner gerotor disposed at least partially within the outer gerotor chamber;
 - a seal formed between the housing and the outer gerotor, the seal operable to restrict the passage of fluid between the outer gerotor chamber and a region outside the outer gerotor chamber;
 - a seal portion of the housing; and
 - one or more seal protrusions coupled to the at least one of the outer gerotor and the inner gerotor, the one or more seal protrusions configured to contact the seal portion.
- 9. The apparatus of claim 8, wherein the seal comprises a labyrinthian seal.
- 10. The apparatus of claim 8, wherein:
 - the seal portion of the housing is formed from a soft material; and
 - the one or more seal protrusions are formed from a hard material.
- 11. The apparatus of claim 8, wherein:
 - the seal portion of the housing is formed from an abradable material;
 - at least one of the one or more seal protrusions is configured to form one or more seal tracks by abrading into the seal portion of the housing.

54

- 12. The apparatus of claim 11, wherein the at least one of the one or more seal protrusions comprises one or more indentations configured to receive particles produced when the at least one of the one or more seal protrusions abrades the seal portion of the housing.
- 13. The apparatus of claim 8, wherein the seal portion of the housing is spring loaded.
- 14. The apparatus of claim 8, wherein the seal portion of the housing is biased against the one or more seal protrusions.
- 15. A gerotor apparatus, comprising:
 - a housing;
 - an outer gerotor disposed at least partially within the housing, the outer gerotor at least partially defining an outer gerotor chamber;
 - an inner gerotor disposed at least partially within the outer gerotor chamber; and
 - a labyrinthian seal formed between the housing and the outer gerotor, the labyrinthian seal operable to restrict the passage of fluid between the outer gerotor chamber and a region outside the outer gerotor chamber, the labyrinthian seal formed by one or more seal protrusions coupled to the at least one of the outer gerotor and the inner gerotor coming into contact with a seal portion of the housing.
- 16. The apparatus of claim 15, wherein:
 - the seal portion of the housing is formed from a soft material; and
 - the one or more seal protrusions are blades that cut into the soft material.
- 17. The apparatus of claim 15, wherein:
 - the seal portion of the housing is formed from an abradable material;
 - at least one of the one or more seal protrusions is configured to form one or more seal tracks by abrading into the seal portion of the housing.
- 18. The apparatus of claim 15, wherein the seal portion of the housing is biased against the one or more seal protrusions.

* * * * *