



US008622352B2

(12) **United States Patent**
Roop

(10) **Patent No.:** **US 8,622,352 B2**
(45) **Date of Patent:** **Jan. 7, 2014**

(54) **GUIDEWAY SWITCHING MECHANISM**

(75) Inventor: **Stephen S. Roop**, College Station, TX (US)

(73) Assignee: **The Texas A&M University System**, College Station, TX (US)

(*) Notice: Subject to any disclaimer, the term of this patent is extended or adjusted under 35 U.S.C. 154(b) by 0 days.

(21) Appl. No.: **13/544,196**

(22) Filed: **Jul. 9, 2012**

(65) **Prior Publication Data**

US 2012/0272856 A1 Nov. 1, 2012

Related U.S. Application Data

(63) Continuation of application No. 12/248,813, filed on Oct. 9, 2008, now Pat. No. 8,215,591.

(60) Provisional application No. 60/978,958, filed on Oct. 10, 2007.

(51) **Int. Cl.**
E01B 7/00 (2006.01)

(52) **U.S. Cl.**
USPC **246/415 R**; 104/130.11

(58) **Field of Classification Search**
USPC 104/130.11, 130.06; 246/430, 435 R, 246/442, 276
See application file for complete search history.

(56) **References Cited**

U.S. PATENT DOCUMENTS

2,997,004 A * 8/1961 Rosebaum et al. 104/130.11
3,013,504 A * 12/1961 Schutze 104/130.11
3,095,827 A * 7/1963 Chadenson 104/130.01

3,310,004 A * 3/1967 Chadenson 104/130.09
3,472,176 A * 10/1969 Trent 104/130.11
5,292,091 A * 3/1994 Callegari et al. 246/258
5,620,156 A * 4/1997 Berggren et al. 246/221
6,499,701 B1 * 12/2002 Thornton et al. 246/194
6,543,727 B2 * 4/2003 Click et al. 246/452
7,458,454 B2 * 12/2008 Mendenhall 198/463.2
7,484,695 B2 * 2/2009 Cavalli 246/415 R
2002/0060273 A1 * 5/2002 Schwiede 246/452
2009/0095846 A1 * 4/2009 Roop 246/415 R

FOREIGN PATENT DOCUMENTS

DE 2148 697 A1 4/1973
DE 10 2004 015 495 A1 10/2005 E01B 25/34
NL 6 603 188 A 6/1966

OTHER PUBLICATIONS

European Patent Office, Communication Pursuant to Article 94(3) EPC for Application No. 08 837 901.1-2303, transmitted to Baker Botts L.L.P. on Nov. 23, 2012, 4 pages.
PCT Invitation to Pay Additional Fees and, where applicable, Protest Fee, (and partial International Search Report) regarding PCT Application No. US2008/079495 (5 pages), Jan. 28, 2009.

(Continued)

Primary Examiner — Jason C Smith
(74) *Attorney, Agent, or Firm* — Baker Botts L.L.P.

(57) **ABSTRACT**

According to one embodiment, a guideway switching mechanism includes an elongated section of flexible guideway coupled to a switch plate. The flexible guideway has a first end that may be coupled to a first elongated guideway and a second end that may be selectively coupled to one of a multiple quantity of alternative guideways. The switch plate provides selective coupling of the flexible guideway to multiple alternative guideways by movement through an arcuate path such that the automated transport vehicle may selectively move from the first elongated guideway to either of the alternative guideways.

20 Claims, 4 Drawing Sheets

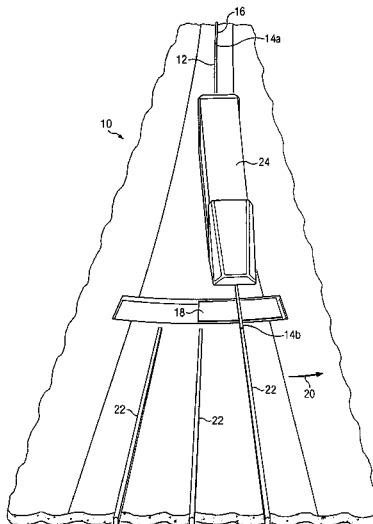

(56)

References Cited

OTHER PUBLICATIONS

PCT Notification of Transmittal of the International Search Report and the Written Opinion of the International Searching Authority regarding PCT Application No. US2008/079495 (15 pages), Apr. 14, 2009.

The First Office Action issued by the State Intellectual Property Office of the People's Republic of China; Application No. 200880111164.4, Chinese Office Action and English translation, transmitted to Baker Botts L.L.P. Nov. 15, 2011 (19 pages).

The Patent Office of the People's Republic of China, The Second Office Action for Application No. 200880111164.4, transmitted to Baker Botts on Sep. 12, 2012, 23 pages (with translation).

* cited by examiner

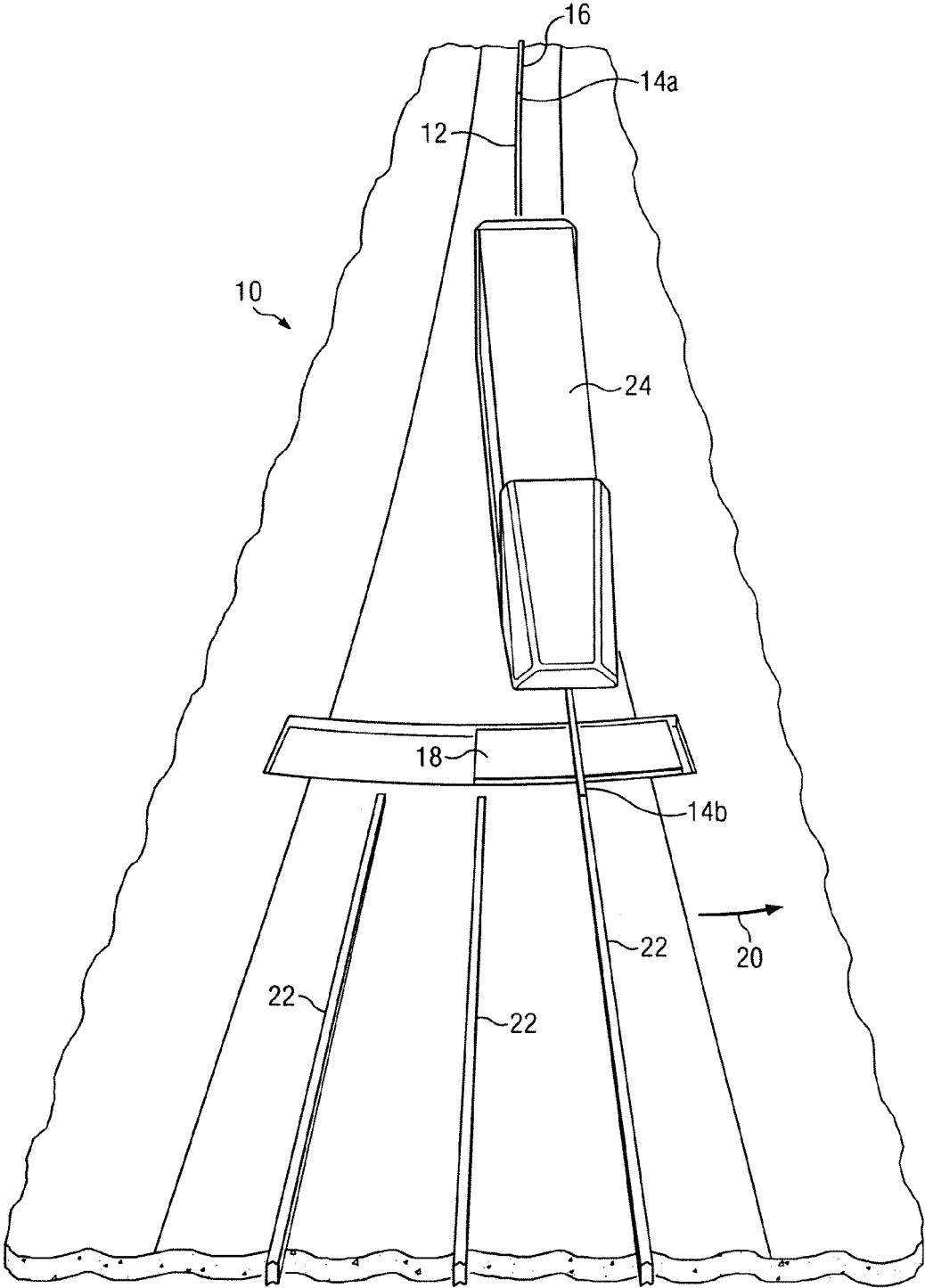

FIG. 1

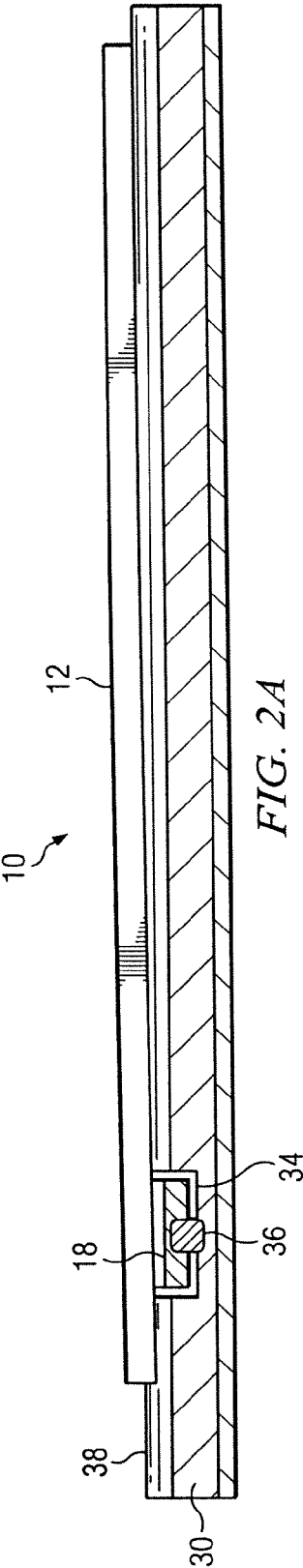

FIG. 2A

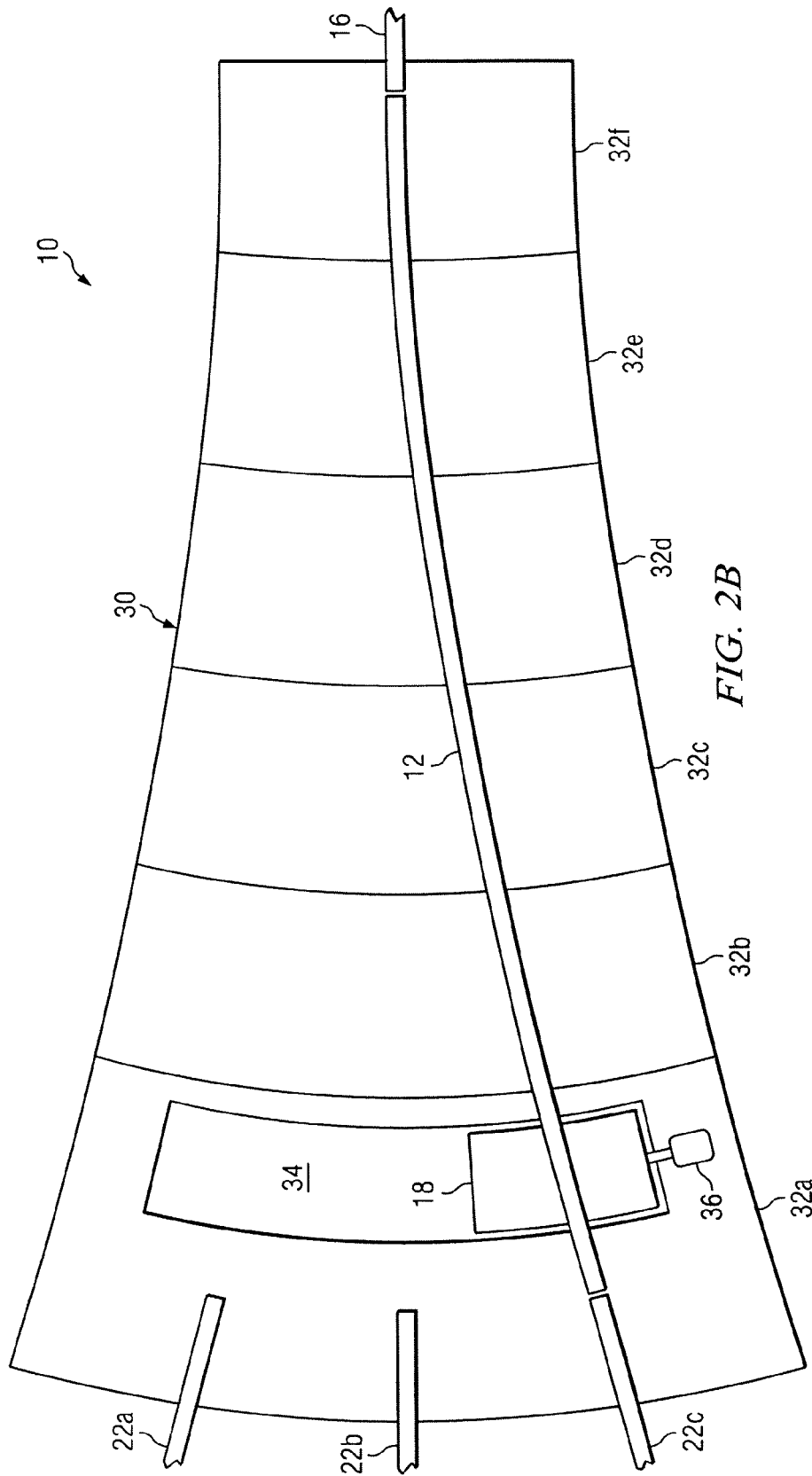

FIG. 2B

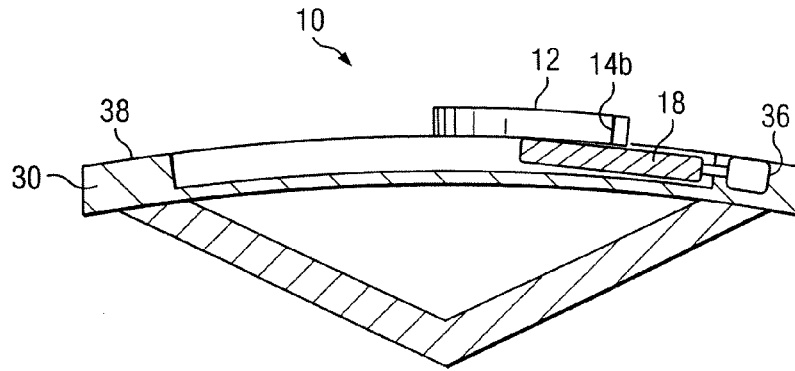

FIG. 2C

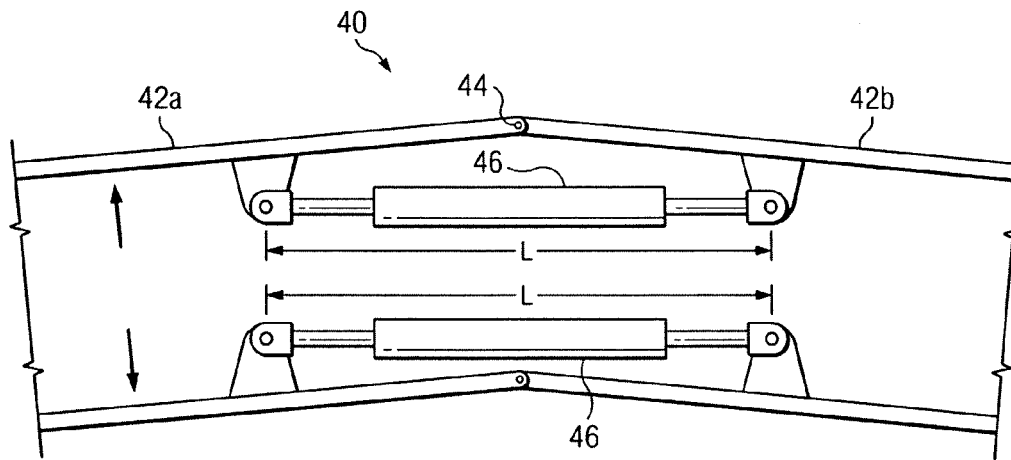

FIG. 3

1

GUIDEWAY SWITCHING MECHANISM

RELATED APPLICATIONS

This application is a continuation of U.S. application Ser. No. 12/248,813 which was filed on Oct. 9, 2008, entitled "GUIDEWAY SWITCHING SYSTEM" now U.S. Pat. No. 8,215,591. U.S. application Ser. No. 12/248,813 claims priority to U.S. Provisional Patent Application Ser. No. 60/978,958, entitled "GUIDEWAY SWITCHING MECHANISM," which was filed on Oct. 10, 2007.

TECHNICAL FIELD OF THE DISCLOSURE

This disclosure generally relates to guideway systems, and more particularly, to a guideway switching mechanism for a guideway system.

BACKGROUND OF THE DISCLOSURE

A guideway system generally refers to a type of transportation system in which automated transport vehicles are guided along predetermined paths using a guideway made of structurally rigid materials including metal and/or concrete. While typical railway systems use a pair of elongated steel rails that are spaced apart a specified distance from one another and configured to guide its associated transport vehicles using flange-shaped wheels, guideway systems utilize a single elongated guideway for guidance of its associated transport vehicles. The guideway provides guidance of the automated transport vehicle along specified paths and may include running surfaces for support of the wheels of the automated transport vehicle.

SUMMARY OF THE DISCLOSURE

According to one embodiment, a guideway switching mechanism includes an elongated section of flexible guideway coupled to a switch plate. The flexible guideway has a first end that may be coupled to a first elongated guideway and a second end that may be selectively coupled to one of a multiple quantity of alternative guideways. The switch plate provides selective coupling of the flexible guideway to multiple alternative guideways by movement through an arcuate path such that the automated transport vehicle may selectively move from the first elongated guideway to either of the alternative guideways.

Some embodiments of the disclosure may provide numerous technical advantages. Some embodiments may benefit from some, none, or all of these advantages. For example, according to one embodiment, flexible guideway may provide motive force the automated transport vehicle while moving through the guideway switching mechanism. This may be due, at least in part to the properties of the guideway that remain essentially continuous throughout the guideway switching mechanism. For linear induction motors, therefore, that generate motive force using the guideway, the automated transport vehicle may remain under power while transitioning through the guideway switching mechanism.

Other technical advantages may be readily ascertained by one of ordinary skill in the art.

BRIEF DESCRIPTION OF THE DRAWINGS

A more complete understanding of embodiments of the disclosure will be apparent from the detailed description taken in conjunction with the accompanying drawings in which:

2

FIG. 1 is a perspective view of one embodiment of the guideway switching mechanism according to the teachings of the present disclosure;

FIG. 2A is a cross-sectional, side elevational view of the guideway switching mechanism of FIG. 1;

FIG. 2B is a top view of the guideway switching mechanism of FIG. 1;

FIG. 2C is a cross-sectional, front elevational view of the guideway switching mechanism of FIG. 1; and

FIG. 3 is a partial diagram view of an alternative embodiment of a flexible guideway that may be used with the guideway switching mechanism of FIG. 1.

DETAILED DESCRIPTION OF EXAMPLE EMBODIMENTS

Guideway systems incorporating a single elongated guideway may provide certain advantages over railway systems having multiple rails. For example, guideways may be used in conjunction with linear induction motors to provide a motive force for movement of transport vehicles along the guideway. Switching of the transport vehicle among multiple guideways or paths is not easily accomplished, however, due to their obstruction of the wheels of transport vehicle when extending in a path that is different from the chosen path of the transport vehicle.

FIG. 1 shows one embodiment of a guideway switching mechanism 10 that may provide a solution to this problem and other problems. Guideway switching mechanism 10 generally includes an elongated section of flexible guideway 12 having one end 14a that is coupled to a first elongated guideway 16 and a second end 14b coupled to a switch plate 18. According to the teachings of the present disclosure, flexible guideway 12 may bend along a generally horizontal arc 20 to selectively couple flexible guideway 12 to one of three alternative guideways 22a, 22b, or 22c such that automated transport vehicle 24 may selectively move from first guideway 16 to either of the three alternative guideways 22a, 22b, or 22c. In the particular embodiment shown, three alternative guideways 22a, 22b, and 22c are shown; however, guideway switching mechanism 10 may be configured to switch flexible guideway 12 among any quantity of alternative guideways 22 such as two, four, or more alternative guideways 22.

Automated transport vehicle 24 may be any type of vehicle suitable for movement along first guideway 16, alternative guideways 22a, 22b, and 22c, and flexible guideway 12. In one embodiment, motive force for movement of automated transport vehicle 24 may be provided by a linear induction motor (not specifically shown) in which first guideway 16, alternative guideways 22a, 22b, and 22c, and flexible guideway 12 serves as a stator portion of the linear induction motor. Certain embodiments of the present disclosure may provide an advantage in that the flexible guideway 12 may continue to provide motive force for automated transport vehicle while transitioning through the guideway switching mechanism 10.

In one embodiment, guideway switching mechanism 10 may be implemented such that automated transport vehicle 24 diverges from one first guideway 16 to one of multiple alternative guideways 22a, 22b, or 22c. In another embodiment, guideway switching mechanism 10 may be implemented such that the automated transport vehicle 24 merges from multiple alternative guideways 22a, 22b, and 22c into a single first guideway 16. That is, the switching function of the guideway switching mechanism 10 may be reversed to provide a merging operation from among a plurality of alterna-

3

tive guideways **22a**, **22b**, and **22c** as opposed to diverging from a single first guideway **16** to multiple alternative guideways **22a**, **22b**, and **22c**.

FIGS. **2A** through **2C** show side elevational, top, and front elevational views, respectively, of guideway switching mechanism **10**, which is formed in this embodiment, on a pre-fabricated support substrate **30**. Pre-fabricated support substrate **30** may be made of any suitable material having sufficient strength for supporting the weight of a loaded automated transport vehicle **24** and support lateral forces through flexible guideway **12** for changing the direction of the automated transport vehicle **24**. In one embodiment, support substrate **30** is made of concrete and may include various types of reinforcement material, such as wire mesh or rebar.

The term "pre-fabrication" may be referred to, in this disclosure, as the act of creating support substrate **30** at one location, and subsequently installing and using the created support substrate **30** at a different location. In one embodiment, guideway switching mechanism **10** may be fabricated in multiple sub-sections **32a** through **32f** (FIG. **2B**). Each of these sub-sections **32a** through **32f** may be individually transported and subsequently assembled at a desired location of use. In one example, guideway switching mechanism **10** may be approximately twenty feet wide at its widest point and approximately 180 feet long. This guideway switching mechanism **10** may therefore, have six sub-sections **32a** through **32f** that are each approximately 30 feet long.

Bending of flexible guideway **12** may be provided by a switch plate **18**. Switch plate **18** is disposed in a generally arc-shaped cavity **34** that allows the switch plate **18** to freely move in a generally lateral arcuate path. An actuator **36** may be provided for movement of the switch plate **18**. The actuator **36** may be any suitable type, such as a hydraulic piston, a servo mechanism, or an electric motor.

The length of travel of the switch plate **18** may be based upon the quantity of alternative guideways **22a**, **22b**, and **22c** implemented and the breadth of the wheels of automated transport vehicle **24**. For example, to provide for clearance between the wheels of automated transport vehicle **24** and an adjacent alternative guideway **22a**, **22b**, or **22c**, each alternative guideway **22a**, **22b**, and **22c** may be placed at least half the wheel breadth of automated transport vehicle **24** apart.

The speed at which the actuator **36** is operable to alternatively couple alternative guideways **22a**, **22b**, and **22c** may be directly proportional to the rate at which automated transport vehicles **24** move through guideway switching mechanism **10**. In one embodiment, actuator **36** moves switch plate **18** at a speed of approximately 10 feet-per-second such that automated transport vehicles **24** moving at approximately 90 feet-per-second may be properly guided to their desired alternative guideway **22a**, **22b**, or **22c**.

As best shown in FIG. **2C**, support substrate **30** has an upper surface **38** with a convex shape. The convex shape of upper surface **38** may provide a banking angle or acclivity for automated transport vehicles **24** that are diverted from a straight trajectory due to bending of flexible guideway **12**. In the present embodiment shown for example, diverting automated transport vehicle **24** to either alternative guideway **22a** or **22c** may be provided by bending flexible guideway **12**. In this case, movement of automated transport vehicle **24** along flexible guideway **12** may impart lateral forces on automated guideway vehicle **24** due to centripetal momentum of automated transport vehicle **24**. Banking provided by the convex shape of upper surface **38** in this case may reduce centripetal forces that may in turn, reduce the lateral force placed on flexible guideway **12** when automated transport vehicle is diverted onto guideway **22a** or **22c**.

4

FIG. **3** shows a partial diagram view of an alternative embodiment of a flexible guideway **40** that may be used with the guideway switching mechanism **10** of FIG. **1**. Whereas flexible guideway **12** of FIGS. **1** through **2C** has a lateral flexibility that may be distributed uniformly from its first end **14a** to its second end **14b**, flexible guideway **40** has a plurality of rigid sub-sections **42a** and **42b** that are hingedly coupled together at relatively equally spaced apart intervals from its first end to second end. In the particular illustration shown, only two sub-sections **42a** and **42b** are shown; however, it should be understood that flexible guideway **40** may have any quantity of sub-sections **42a** and **42b** that are hingedly coupled together at regularly spaced intervals.

Lateral bending of rigid sub-sections **42a** and **42b** relative to one another may be provided by articulation along a joint **44**. A multiple quantity of joints **44** configured on flexible guideway **40** allows it to bend along an arc for selectively coupling second end **14b** to either of alternative guideways **22**. The stiffness of joint **44** may also be controlled from a relatively low stiffness to allow bending to a relatively high stiffness for guiding automated transport vehicle **24** along its selected path.

Selective stiffness of joint **44** may be provided by any suitable approach. In the particular embodiment shown, two pistons **46** are included that are coupled at either end to adjacent sub-sections **42a** and **42b**. Pistons **46** have a length **L** that varies proportionally with articulation of joints **44** and have an adjustable stiffness. The stiffness of pistons **46** generally refers to their level of resistance to a change in its length **L**. Thus, by controlling the stiffness of pistons **46**, the relative stiffness of joint **44** is effectively controlled. In the particular embodiment shown, two pistons **46** are used to control the stiffness of joint **44**; however, any quantity of pistons **46**, such as one piston, or three or more pistons may be used to control the stiffness and thus lateral articulation of their associated joint **44**.

In one embodiment, pistons **46** may be filled with a magneto rheological fluid to control its stiffness. A magneto rheological fluid is a substance having a viscosity that varies according to an applied magnetic field. Typical magneto rheological fluids include ferro-magnetic particles that are suspended in a carrier fluid, such as mineral oil, synthetic oil, water, or glycol, and may include one or more emulsifying agents that maintain suspension of these ferro-magnetic particles in the carrier fluid. Pistons **46** may operate, therefore, in the presence of a magnetic field to control the stiffness of pistons **46** and thus, the stiffness of joint **44** to which they are coupled.

Modifications, additions, or omissions may be made to guideway switching system **10** without departing from the scope of the disclosure. The components of guideway switching system **10** may be integrated or separated. For example, flexible guideway **12** may be integrally formed with switch plate **18** such that actuator **36** is directly coupled to flexible guideway **12**. Moreover, the operations of guideway switching system **10** may be performed by more, fewer, or other components. For example, support substrate **30** may include other structural features not specifically described to support the weight of automated transport vehicle **24** and/or maintain flexible guideway **40** in proper alignment with first elongated guideway **16** and alternative guideways **22**. Additionally, operations of actuator **36** and/or pistons **46** may be controlled by a suitable controller that may include, for example, logic comprising software, hardware, and/or other suitable forms of logic. As used in this document, "each" refers to each member of a set or each member of a subset of a set. Additionally, the drawings are not necessarily drawn to scale.

Although the present disclosure has been described with several embodiments, a myriad of changes, variations, alterations, transformations, and modifications may be suggested to one skilled in the art, and it is intended that the present disclosure encompass such changes, variations, alterations, transformation, and modifications as they fall within the scope of the appended claims.

What is claimed is:

1. A guideway switching mechanism comprising:
 - a elongated section of flexible guideway having a first end and a second end, the first end operable to be coupled to a first elongated guideway;
 - a support substrate providing substantially continuous support of the elongated section of flexible guideway from the first end to the second end, an upper surface of the support substrate having a convex shape that creates a banking angle from the first end to the second end of the elongated section of flexible guideway; and
 - a switch plate coupled to the flexible guideway proximate the second end and operable to bend the flexible guideway to selectively couple the second end to two or more second elongated guideways such that an automated transport vehicle may be guided by the elongated section from the first elongated guideway to either of the two or more second elongated guideways, wherein the switch plate is disposed in a horizontally oriented arc-shaped cavity formed in the support substrate and the switch plate moves within the horizontally oriented arc shaped cavity to selectively bend the flexible guideway while maintaining the properties of the flexible guideway.
2. The guideway switching mechanism of claim 1, wherein the switch plate is further operable to bend the flexible guideway through the horizontally oriented arc such that the automated transport vehicle may be guided by the elongated section from either of the two or more second elongated guideways to the first elongated guideway.
3. The guideway switching mechanism of claim 1, wherein the upper surface is coupled to the first end and a cavity for placement of the switch plate, the cavity having an arc-like shape such that the switch plate may freely move along the horizontally oriented arc.
4. The guideway switching mechanism of claim 1, wherein the support substrate is substantially made of concrete.
5. The guideway switching mechanism of claim 1, wherein the support substrate is formed of a plurality of sub-sections that are joined together to form a continuous support substrate, the plurality of sub-sections being operable to be joined together at a desired location of use.
6. The guideway switching mechanism of claim 1, wherein the switch plate is moved through the horizontally oriented arc using an actuator that is selected from the group consisting of a hydraulic piston, a servo mechanism, and an electric motor.
7. The guideway switching mechanism of claim 1, wherein the flexible guideway is operable to be used in conjunction with a linear induction motor.
8. The guideway switching mechanism of claim 1, wherein the flexible guideway has a lateral flexibility that is distributed uniformly from its first end to its second end.
9. The guideway switching mechanism of claim 1, wherein the flexible guideway comprises a plurality of rigid sub-sections that are hingedly coupled together at equally spaced apart intervals from the first end to the second end.
10. The guideway switching mechanism of claim 9, wherein each rigid sub-section is coupled to an adjacent rigid sub-section with a piston that is operable to selectively adjust

a lateral flexibility of the adjacent rigid sub-section relative to the each rigid subsection from a generally flexible state, to a generally rigid state.

11. The guideway switching mechanism of claim 10, wherein the piston comprises a magneto rheostatic fluid having a viscosity that is selectively adjustable from a low viscosity to a high viscosity under the influence of a magnetic field.

12. The switching mechanism of claim 1, wherein the convex shape of the upper surface of the support substrate curves upward toward the elongated section of flexible guideway to create the banking angle from the first end to the second end of the elongated section of flexible guideway.

13. A method comprising:

- moving an automated transport vehicle along a first elongated guideway that has a first end and a second end and is coupled to a flexible guideway at the first end;
- forming a support substrate having an upper surface having a convex shape that creates a banking angle from the first end to the second end of the elongated section of flexible guideway;
- providing a switch plate disposed in a horizontally oriented arc-shaped cavity formed in the support substrate;
- continuously supporting the flexible guideway from the first end to the second end on the support substrate;
- moving the switch plate horizontally oriented arc shaped cavity to selectively bend the flexible guideway through the horizontally-oriented arc to couple its second end to one of a plurality of second elongated guideways while maintaining the properties of the flexible guideway; and
- traversing the flexible guideway, by the automated transport vehicle, to proceed along the one second elongated guideway.

14. The method of claim 13, further comprising moving the automated transport vehicle along the second elongated guideway and traversing the flexible guideway, by the automated transport vehicle, to proceed along the first elongated guideway.

15. The method of claim 13, wherein forming the support substrate comprises joining together, at a desired location of use, a plurality of sub-sections to form a continuous support substrate, the support substrate coupled to the flexible guideway at its first end.

16. The method of claim 13 wherein bending the flexible guideway further comprises bending the flexible guideway using an actuator that is selected from the group consisting of a hydraulic piston, a servo mechanism, and an electric motor.

17. The method of claim 16, further comprising moving the automated transport vehicle along the flexible guideway using a linear induction motor, the flexible guideway comprising a stator portion of the linear induction motor.

18. The method of claim 16, wherein bending the flexible guideway through a horizontally oriented arc further comprises bending the flexible guideway comprising a plurality of rigid sub-sections that are hingedly coupled together at equally spaced apart intervals from the first end to the second end, each rigid subsection being coupled to an adjacent rigid subsection with a piston, and increasing the stiffness of the piston to increase the stiffness of each rigid sub-section to its adjacent rigid sub-section.

19. The method of claim 18, wherein the piston comprises a magneto rheostatic fluid having a viscosity that is selectively adjustable from a low viscosity to a high viscosity under the influence of a magnetic field.

20. The method of claim 13, wherein the convex shape of the upper surface of the support substrate curves upward toward the elongated section of flexible guideway to create

the banking angle from the first end to the second end of the elongated section of flexible guideway.

* * * * *