



(12) **United States Patent**  
**Alberson et al.**

(10) **Patent No.:** **US 7,597,501 B2**  
(45) **Date of Patent:** **Oct. 6, 2009**

(54) **HYBRID ENERGY ABSORBING REUSABLE TERMINAL**

(75) Inventors: **Dean C. Alberson**, Bryan, TX (US); **D. Lance Bullard, Jr.**, College Station, TX (US); **Christopher J. Karpathy**, Dallas, TX (US); **John F. Carney, III**, Falmouth, MA (US)

(73) Assignee: **The Texas A&M University System**, College Station, TX (US)

(\* ) Notice: Subject to any disclaimer, the term of this patent is extended or adjusted under 35 U.S.C. 154(b) by 0 days.

(21) Appl. No.: **11/678,697**

(22) Filed: **Feb. 26, 2007**

(65) **Prior Publication Data**

US 2007/0134062 A1 Jun. 14, 2007

**Related U.S. Application Data**

(63) Continuation of application No. 10/091,838, filed on Mar. 6, 2002, now Pat. No. 7,246,791.

(51) **Int. Cl.**  
**E01F 15/08** (2006.01)

(52) **U.S. Cl.** ..... **404/6; 404/10**

(58) **Field of Classification Search** ..... **404/6, 404/10; 188/372; 256/13.1**  
See application file for complete search history.

(56) **References Cited**

**U.S. PATENT DOCUMENTS**

1,784,468 A *	12/1930	Soprani	84/376 R
3,643,924 A	2/1972	Fitch	256/13.1
3,693,940 A	9/1972	Kendall et al.	256/1
3,768,781 A	10/1973	Walker et al.	251/1
3,856,268 A	12/1974	Fitch	256/13.1
3,919,380 A	11/1975	Smarook et al.	264/164
3,982,734 A	9/1976	Walker	256/13.1

4,084,914 A	4/1978	Humphrey et al.	404/10
4,190,275 A	2/1980	Mileti	293/102
4,200,310 A	4/1980	Carney, III	280/784
4,307,973 A	12/1981	Glaesener	404/10
4,352,484 A	10/1982	Gertz et al.	256/13.1
4,399,980 A	8/1983	van Schie	256/13.1
4,452,431 A	6/1984	Stephens et al.	256/13.1
4,583,716 A	4/1986	Stephens et al.	256/13.1
4,596,489 A	6/1986	Mariol et al.	404/10
4,645,375 A	2/1987	Carney, III	404/6
4,674,911 A	6/1987	Gertz	404/6
4,784,515 A	11/1988	Krage et al.	404/6
4,815,565 A	3/1989	Sicking et al.	404/6
4,844,213 A	7/1989	Travis	188/377

(Continued)

*Primary Examiner*—Gary S Hartmann  
(74) *Attorney, Agent, or Firm*—Baker Botts L.L.P.

(57) **ABSTRACT**

An energy absorbing terminal is described that is made up of a plurality of cells partially defined by cambered panels made of thermoplastic or another suitable material. The panels are supported upon rectangular frames. The cambered portion of the panels provides a predetermined point of flexure for each panel and, thus, allows for energy dissipation during a collision. The stiffness of the crash cushion may be varied by altering material thicknesses and diaphragm spacing. In operation, a vehicle colliding in an end-on manner with the upstream end of the energy absorbing terminal will cause each of the cambered panels to bend angularly at its point of flexure and, thus, cause the cells to collapse axially. The use of thermoplastic, such as polyethylene results in a reversible, self-restoring collapse for the terminal, meaning that the terminal is reusable after most collisions.

**43 Claims, 4 Drawing Sheets**

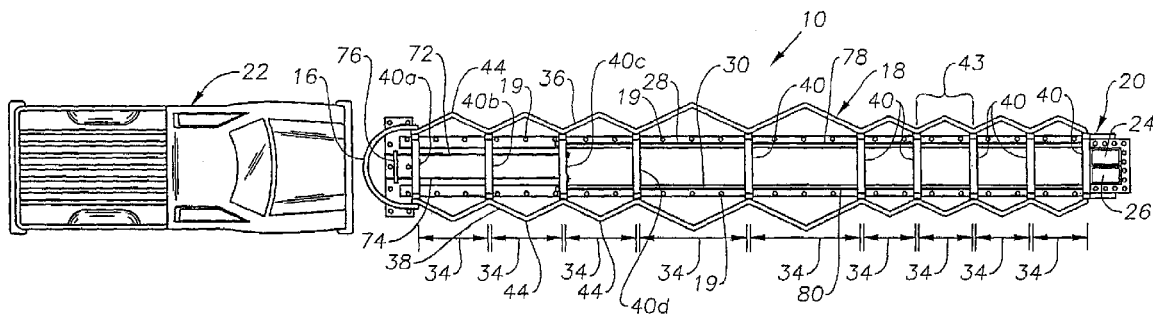

# US 7,597,501 B2

Page 2

## U.S. PATENT DOCUMENTS

5,011,326	A	4/1991	Carney, III	404/6	6,092,959	A	7/2000	Leonhardt et al.	404/6
5,054,954	A	10/1991	Cobb et al.	404/6	6,116,805	A	9/2000	Gertz	256/13.1
5,112,028	A	5/1992	Laturner	256/13.1	6,203,079	B1	3/2001	Breed	293/119
5,248,129	A	9/1993	Gertz	256/13.1	6,220,575	B1	4/2001	Lindsay et al.	256/13.1
5,403,112	A	4/1995	Carney, III	404/6	6,276,667	B1	8/2001	Arthur	256/13.1
5,718,413	A	2/1998	Nagler	256/13.1	6,293,727	B1	9/2001	Albritton	404/6
5,733,062	A	3/1998	Oberth et al.	404/6	6,308,809	B1	10/2001	Reid et al.	188/377
5,746,419	A	5/1998	McFadden et al.	267/140	6,340,268	B1	1/2002	Alberson et al.	404/6
5,775,675	A	7/1998	Sicking et al.	256/13.1	6,461,076	B1	10/2002	Stephens et al.	404/6
5,797,592	A	8/1998	Machado	256/13.1	6,533,250	B2	3/2003	Arthur	256/13.1
5,823,584	A	10/1998	Carney, III	293/102	6,536,985	B2	3/2003	Albritton	404/6
5,851,005	A	12/1998	Muller et al.	256/13.1	6,551,010	B1	4/2003	Kiedaish et al.	404/6
5,868,521	A	2/1999	Oberth et al.	404/6	6,637,971	B1	10/2003	Carney, III et al.	404/6
5,957,435	A	9/1999	Bronstad	256/13.1	6,863,467	B2	3/2005	Buehler et al.	404/6
6,010,275	A *	1/2000	Fitch	404/6	7,112,004	B2	9/2006	Alberson et al.	404/6
					7,246,791	B2 *	7/2007	Alberson et al.	256/13.1

\* cited by examiner

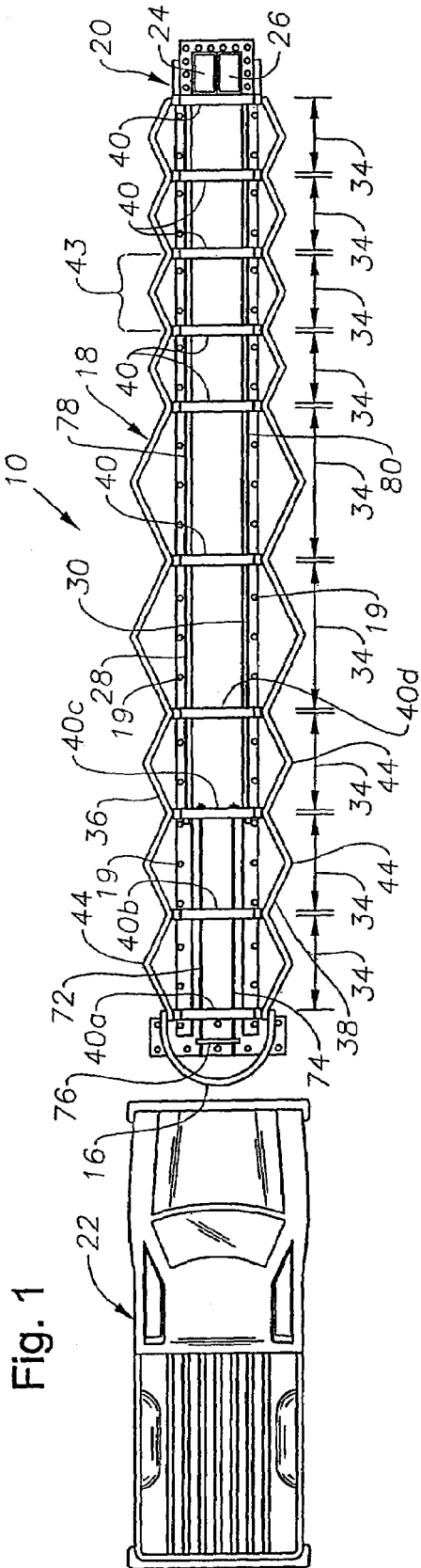

Fig. 1

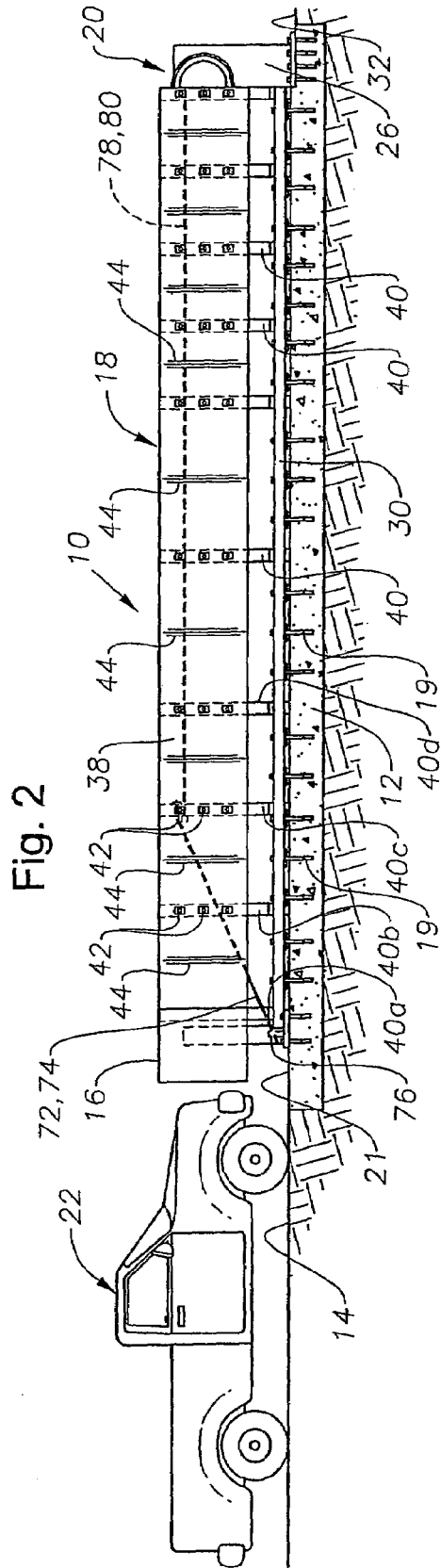

Fig. 2



Fig. 4

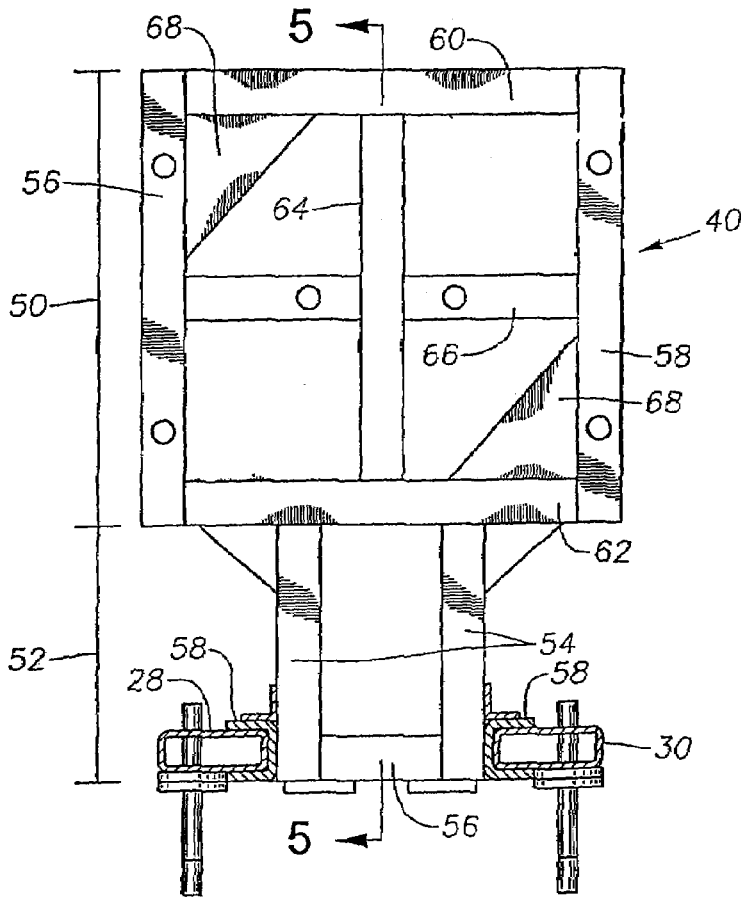

Fig. 5

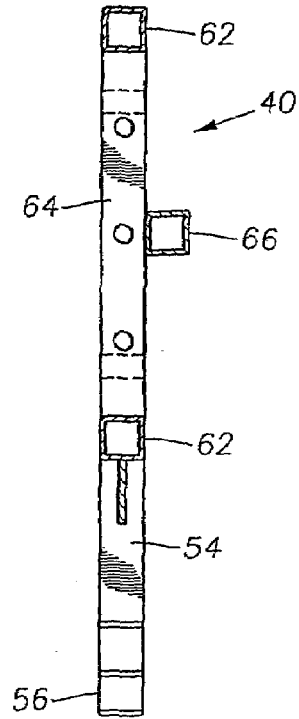
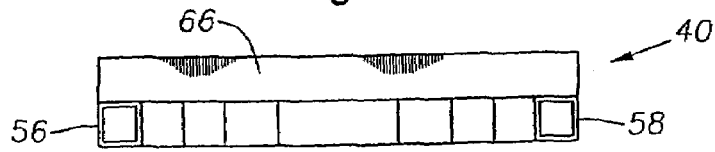
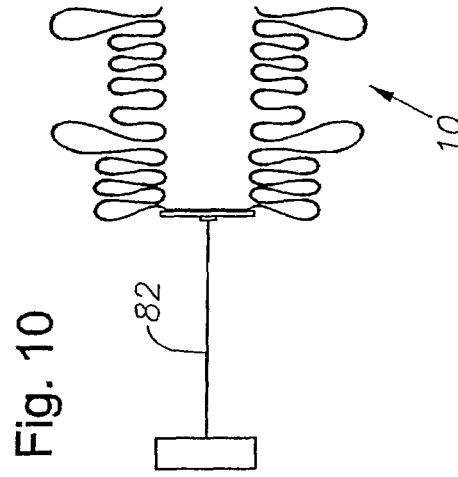
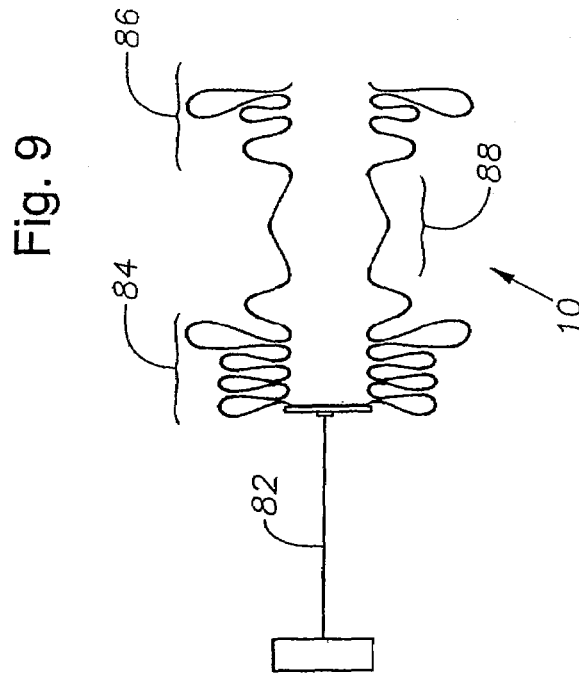
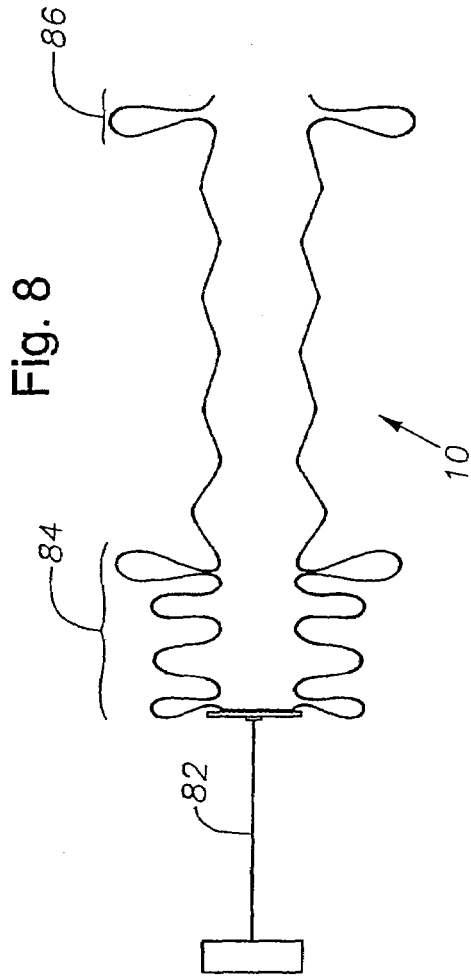

Fig. 6





1

## HYBRID ENERGY ABSORBING REUSABLE TERMINAL

### CROSS REFERENCE TO RELATED APPLICATIONS

This application is a continuation of U.S. patent application Ser. No. 10/091,838 filed by Dean C. Alberson, et al., on Mar. 6, 2002, which is hereby incorporated by reference.

This application is related to U.S. patent application Ser. No. 10/967,886 filed by Dean C. Alberson et al., Oct. 18, 2004, now U.S. Pat. No. 7,112,004.

### TECHNICAL FIELD OF THE INVENTION

The present invention relates generally to crash cushions and terminals used in highway applications to mitigate and preclude injuries to occupants of errant vehicles.

### BACKGROUND OF THE INVENTION

Roadway crash cushions are widely used to absorb impacts and decelerate impacting vehicles in a controlled manner. Typically, crash cushions are positioned to shield fixed objects located within the roadway environment. Crash cushions are often positioned in front of obstacles such as concrete columns and abutments. Also, crash cushions are often located at the end of a guardrail installation to prevent the upraised end of the guardrail from spearing an impacting vehicle.

There are numerous crash cushion designs known that rely upon frangible members, or members that are intended to shatter or be destroyed upon impact, to absorb the energy associated with a vehicular impact. Examples are found in U.S. Pat. No. 3,768,781 issued to Walker et al. and U.S. Pat. No. 3,982,734 issued to Walker (both employing energy cells having internal frangible members of e.g., vermiculite). One problem with the use of frangible members is the crash cushion must be completely replaced after each collision. Thus, time and expense is incurred in replacing the frangible members.

A number of previous crash cushion designs rely upon the permanent deformation of plastics or steels to absorb the kinetic energy of errant impacting vehicles. A design of that nature suffers from the same drawbacks as those designs incorporating frangible members. The cost and time associated with replacing or repairing the deformed portions of the cushion is significant.

There have been a few attempts to provide reusable or restorable crash cushions. However, for the most part, these attempts have proven impractical or unworkable in practice. U.S. Pat. No. 4,452,431 issued to Stephens et al, for instance, describes a crash cushion wherein fluid filled buffer elements are compressed during a collision. It is intended that energy be absorbed as the fluid is released from the buffer elements under pressure. In practice, it is difficult to maintain the fluid filled cylinders as they are prone to loss of fluid through evaporation, vandalism and the like. Also, after a severe impact, holes or punctures may occur in the buffer elements rendering them incapable of holding fluid.

U.S. Pat. No. 4,674,911 issued to Gertz describes a pneumatic crash cushion that is intended to be reusable. This crash cushion employs a plurality of air chambers and valve members to absorb and dissipate impact energy. This arrangement is relatively complex and prone to failure. In addition, the numerous specialized components used in its construction make it expensive.

2

The Reusable Energy Absorbing Crash Terminal ("RE-ACT") 350 is a crash cushion wherein a plurality of polyethylene cylinders are used to absorb impact energy. The cylinders are retained within a framework of side cables and supporting frames. This system is effective and reusable to a great degree due to the ability of the cylinders to restore themselves after impact. The cylinders typically return to 85%-90% of their original shape after impact. Unfortunately, the REACT system is also expensive to construct. The number of manufacturers producing large diameter polyethylene cylinders is limited and, as a consequence, prices for the cylinders are elevated.

An improvement that addresses the problems of the prior art would be desirable.

### SUMMARY OF THE INVENTION

The present invention provides devices and methods relating to roadway crash cushions. An energy absorbing terminal is described that is made up of a plurality of cells partially defined by cambered panels made of thermoplastic. The panels are supported upon steel diaphragms. The cambered portion of the thermoplastic panels provides a predetermined point of flexure for each panel and, thus, allows for energy dissipation during a collision. The stiffness of the crash cushion is variable by altering material thicknesses and diaphragm spacing.

In operation, a vehicle colliding in an end-on manner with the upstream end of the energy absorbing terminal will cause the cambered panels to bend angularly at their points of flexure and, thus, cause the cells to collapse axially. The use of thermoplastic, such as polyethylene, results in a reversible, self-restoring collapse of the terminal, meaning the terminal is reusable after most collisions.

The invention provides a number of advantages over conventional crash cushions, including cost, ease of construction, and maintenance.

### BRIEF DESCRIPTION OF THE DRAWINGS

FIG. 1 is a plan view of an example crash cushion arrangement constructed in accordance with the present invention prior to impact from an errant vehicle.

FIG. 2 is a side view of the arrangement depicted in FIG. 1.

FIG. 3 is a plan view of the crash cushion depicted in FIGS. 1 and 2 after being struck by an impacting vehicle.

FIG. 4 is a front view of a diaphragm used within the crash cushion shown in FIGS. 1, 2, and 3.

FIG. 5 is a side view of the diaphragm shown in FIG. 4.

FIG. 6 is a plan view of the diaphragm shown in FIGS. 4 and 5.

FIG. 7 is a schematic depiction of an exemplary crash cushion shown prior to an end on impact by a vehicle.

FIG. 8 is a schematic depiction of the crash cushion shown in FIG. 7, at approximately 0.18 seconds following an end-on impact.

FIG. 9 is a schematic depiction of the crash cushion shown in FIG. 7, at approximately 0.27 seconds following an end-on impact.

FIG. 10 is a schematic depiction of the crash cushion shown in FIG. 7, at approximately 0.345 seconds following an end-on impact.

### DETAILED DESCRIPTION OF THE INVENTION

FIGS. 1-3 illustrate an example hybrid energy absorbing reusable terminal ("HEART") crash cushion 10 that is con-

structured in accordance with the present invention. The crash cushion **10** is shown installed on a concrete pad **12** (visible in FIG. **2**) that has been placed within a section of ground **14**. Although not shown, it should be understood that the crash cushion **10** is typically installed adjacent a rigid obstacle, such as a bridge abutment, concrete post or other barrier. In addition, the crash cushion **10** may be located at the upstream end of a guardrail installation.

The crash cushion **10** includes a nose portion **16**, central body portion **18** and downstream end portion **20**. An approaching vehicle **22** is shown adjacent the nose portion **16** of the cushion **10** in FIGS. **1** and **2**. The nose portion **16** consists of a sheet of plastic, or other suitable material, that is curved or bent into a "u" shape. The nose portion **16** may be painted with a bright color, such as yellow, or have reflective tape applied so that the cushion **10** may be easily recognized by drivers. The downstream end portion **20** includes a pair of upstanding rigid posts **24**, **26** that are typically formed of concrete or steel and are securely anchored, either to the ground **32** or to an adjacent abutment, post or other barrier (not shown).

The central body portion **18** also includes a steel basetrack formed from a pair of parallel rail members **28**, **30** that are attached to the ground **32**. Anchor members **19**, such as bolts, are typically used to secure the rail members **28,30** to a concrete slab **21**. The central body portion **18** features a plurality of openings **34** that are arranged linearly along the length of the cushion **10**. In the described embodiment, the openings **34** are shown to be hexagonally shaped. While the hexagonal shape is presently preferred, it should be understood that other suitable shapes may be used, including, for example, octagonal, rectangular and square. The central body portion **18** incorporates two substantially parallel rows **36**, **38** of cambered panels that are arrayed in an end-to-end manner along their lengths. The panel rows **36**, **38** may comprise a single integrally formed sheet of plastic. Alternatively, they may be formed of a number of individual cambered panel members placed in an end-to-end, adjoining manner at each rectangular frame **40**. It is presently preferred that the rows of panel members **36**, **38** be formed of polyethylene. A suitable polyethylene material for use in this application is PPI recommended designation PE3408 high molecular weight, high density polyethylene. A currently preferred thickness for the panel members **36**, **38** is approximately 1¼". It is noted that the panel members **36**, **38** are created so as to be substantially stiff and sturdy in practice and to possess substantial "shape memory" so that they tend to substantially return to their initial form and configuration following elastic deformation. Presently, panel members having a secured in place height of about 20 inches have provided suitable resistance to collapse and sufficiently return to original shape. It is noted that the thickness of a given panel member as well as its height may be adjusted as desired to increase or decrease resistance to expected end-on collision forces. For example, increasing the height of the panel members **36**, **38** will increase the amount of panel material that would be bent by a colliding vehicle and would, therefore, be stiffer than a cushion that incorporated panel members of lesser height.

The crushable cells include rectangular frames or diaphragms **40** that join the parallel panel rows **36**, **38** together. In the drawings, individual diaphragms are designated consecutively from the upstream end of the cushion **10** as diaphragms **40a**, **40b**, **40c**, etc. The diaphragms **40** are preferably formed of steel box beam members welded to one another. In a currently preferred construction, bolts or rivets **42** (visible in FIG. **2**) are used to affix the panel rows **36**, **38** to the frames **40**. Referring now to FIGS. **4-6**, a single exemplary diaphragm,

or frame, **40** is shown in greater detail. The diaphragm **40** includes a widened upper portion, generally shown at **50**, and a narrower lower portion **52**. The lower portion **52** includes a pair of generally vertically oriented support members **54** and a connecting cross-piece **56**. U-shaped engagement shoes **58** are secured to one side of each of the support members **54** and slidably engage the rail members **28**, **30**. The upper portion **50** includes a pair of vertically disposed side members **59** with upper and lower cross-members **60**, **62** that interconnect the side members **59** to form a rectangular frame. Additional vertical and horizontal cross-members **64**, **66**, respectively, are secured to one another within the rectangular frame for added support. Plate gussets **68** are welded into each corner of the rectangular upper portion **50** in order to help to maintain rigidity and stiffness for the diaphragm **40**.

Tension cables are used to provide the crash cushion additional strength and stability and, thereby, materially assist in the lateral redirection of side impacts into the cushion **10**. As shown in FIGS. **1** and **2**, a pair of forward, or upstream, tension cables **72**, **74** are disposed through a forward plate **76**, threaded through the upstream diaphragms **40a**, **40b** and are then secured to the third diaphragm **40c**. A currently preferred method of securing the tension cables to a diaphragm is to secure a threaded end cap (not shown) onto each end of each cable and then thread a nut onto the end cap after passing the end cap through an aperture in the diaphragm. In the exemplary construction shown, a pair of rearward tension cables **78**, **80** are secured to the third diaphragm **40c** and extend rearwardly through corresponding diaphragm apertures toward the downstream end of the central portion **18**.

Longitudinal tension in the cushion **10** is provided by the side panels **36**, **38** that tend to want to remain in a substantially flattened (unfolded) configuration due to shape memory. As noted, prebending of the panels is done to provide a point of planned bending for the panels **36,38** at the cambered portions **44**.

FIGS. **7-10** are schematic representations of a crash cushion constructed in accordance with the present invention and illustrate the mechanics of collapse over time. In FIG. **7**, the cushion **10** has not yet been collapsed by an end on impact. Thus, the cushion **10** is at rest, and in a fully extended position. In FIG. **8**, an end on collision has taken place. The cushion **10** has been impacted by a vehicle (small car), shown schematically as load **82**, traveling at approximately 62 mph. The cushion **10** is shown at approximately 1.8 seconds into the collision in FIG. **8**. As can be seen, the cushion **10** has begun to collapse at two primary locations along its length. One of the locations **84** is proximate the upstream end of the cushion **10**. The second location **86** is proximate the downstream end of the cushion **10**. In FIG. **9**, the cushion **10** is shown approximately 0.27 seconds after the impact. By this time, a third location **88** of axial collapse has begun to form. This third location **88** is proximate the central point along the length of the cushion **10**. In FIG. **10**, the cushion **10** is essentially completely crushed or collapsed.

There are significant advantages to a system that provides for separate collapsing portions spread out in terms of location upon the cushion as well as time. These advantages include efficient use of material and aid in self-restoring nature of cushion. A collapse concentrated in one point along the length could cause that portion of the cushion **10** to be inelastically damaged.

As noted, the cells **34** may be hexagonal, octagonal, rectangular or square in shape, being formed between two adjacent frames **40** and the two panel rows **36,38**. As shown in FIG. **1**, the cells **34** need not all be the same size. The different lengths of the cells provides for differing resistances to col-



5

lapse. The frames **40** have rollers or shoes (not shown) that engage the rails **28, 30** in a manner known in the art so that the frames **40** may move longitudinally along the rails **28, 30**. During an end-on collision with the crash cushion **10**, there is a dynamic wave that propagates through the cushion **10** and may collapse sections other than the lead sections (defined between the upstream frame **40a, 40b, 40c, and 40d**). Additionally, some inertial properties can be used by collapsing the segments in varying order.

It is noted that each of the panel segments, such as segment **43** of each row **36, 38** are cambered at a point **44** approximately midway between adjacent frames **40**. This cambered portion **44** forms a point of flexure and preplanned weakness for the panel segment **43**, thereby permitting the segment **43** to collapse upon the application of an end-on force. The bend also prevents large acceleration spikes from being needed for initial column buckling of the segments **43**. Currently, it is preferred that the amount of bend at the cambered point **44** be about 5-10 degrees, as this amount of bend has been found to provide enough eccentricity to assure proper buckling. The bend at the cambered point **44** may be formed by using a press device of a type known in the art.

In operation, the cells **34** are substantially, reversably compressed during an end-on impact by a vehicle **22**. The use of a resilient, thermoplastic material, such as polyethylene, ensures that the terminal **10** will be self-restoring after minor end-on impacts. The nose **16** may be crushed during the impact, but should be easily replaceable. The posts **24, 26** serve as a reinforcement portion at the downstream end of the terminal **10**. The central portion **18** is compressed against the posts **24, 26**.

The terminal **10** of the present invention provides a number of advantages over prior art terminals. The first is cost. As compared to systems that incorporate polyethylene cylinders, suitable sheets of polyethylene may be obtained readily and inexpensively from a number of suppliers. Secondly, if it becomes necessary to replace one or more of rows **36** or **38**, or individual panels **43** within those rows, this may be accomplished quickly and easily, requiring only removal and replacement of the fasteners **42** used to secure them to the frames **40**.

Those of skill in the art will recognize that many changes and modifications may be made to the devices and methods of the present invention without departing from the scope and spirit of the invention. Thus, the scope of the invention is limited only by the terms of the claims that follow and their equivalents.

What is claimed is:

1. A roadway crash cushion, comprising:

a collapsible, substantially self-restoring collapsing portion comprising a pair of substantially planar and substantially parallel panels, the panels each including a plurality of bends in the panel, the panels being spaced apart such that a plurality of collapsible and substantially self-restoring cells are formed between the pair of panels,

wherein each collapsible and substantially self-restoring cell is formed between a pair of adjacent supporting frames and the pair of substantially parallel panels, only one bend being formed in each panel between the pair of adjacent supporting frames.

2. The roadway crash cushion of claim 1, wherein the plurality of substantially planar panels are formed substantially of at least one material selected from the group consisting of an elastoplastic, a linear elastic, and a thermoplastic material.

6

3. The roadway crash cushion of claim 1 wherein at least one material comprises polyethylene.

4. The roadway crash cushion of claim 1 further comprising a longitudinal, ground-mounted rail member and wherein the pair of adjacent supporting frames engages the rail member for slidable movement along the rail member.

5. The roadway crash cushion of claim 1 wherein each bend provides a point of flexure for the panel.

6. The roadway crash cushion of claim 1 further comprising a nose piece.

7. A roadway crash cushion comprising:

a collapsible cushion portion comprising:

a first panel member being deformed by a plurality of bends in the panel, the first panel configured to collapsibly fold during a collision and, due to shape memory, substantially return to an unfolded condition following a collision; and

a second panel member being deformed by a plurality of bends in the panel, the second panel substantially parallel to the first panel and spaced apart from the first panel such that a plurality of collapsible and substantially self-restoring cells are formed between the first and second panels,

wherein each collapsible and substantially self-restoring cell is formed between a pair of adjacent supporting frames and the first and second panel members, only one bend being formed in each panel member between the pair of adjacent supporting frames.

8. The roadway crash cushion of claim 7, wherein the collapsible cells collapse longitudinally when a longitudinal force is applied to the roadway crash cushion.

9. The roadway crash cushion of claim 8, wherein the first and second panel members comprise a thermoplastic material operable to substantially return the first and second panel members to their initial form after the collapsible cells collapse.

10. The roadway crash cushion of claim 9, wherein the thermoplastic material comprises polyethylene.

11. The roadway crash cushion of claim 8, wherein the pair of adjacent supporting frames comprise a pair of diaphragms, and wherein each diaphragm engages at least one longitudinal, ground-mounted rail member to allow slidable movement of the diaphragms along the rail member as the collapsible cells collapse.

12. The roadway crash cushion of claim 8, wherein the pair of adjacent supporting frames comprise a pair of diaphragms, and wherein each diaphragm engages at least two longitudinal, ground-mounted rail members to allow slidable movement of the diaphragms along the rail member as the collapsible cells collapse.

13. The roadway crash cushion of claim 12, wherein each diaphragm comprises a pair of shoes for slidably engaging the rail members.

14. The roadway crash cushion of claim 7, wherein each bend is located at a point on the first panel member that corresponds with a similar location on the second panel member.

15. The roadway crash cushion of claim 7, wherein each bend is located at a point on the first panel member that corresponds with a midway point within an associated collapsible cell.

16. The roadway crash cushion of claim 7, further comprising:

a tension cable coupling the pair of adjacent supporting frames, the tension cable operable to redirect a force applied perpendicularly to the first panel member.

17. The roadway crash cushion of claim 7, further comprising a nose piece configured to receive a longitudinal force, a first end of the nose piece coupled to the first panel member, a second end of the nose piece coupled to the second panel member.

18. A roadway crash cushion comprising:

a first cambered panel having a first plurality of bends;  
a second cambered panel having a second plurality of bends, each of the second plurality of bends corresponding to one of the first plurality of bends; and  
a plurality of diaphragms coupling the first cambered panel and the second cambered panel, the diaphragms cooperating with the first and second cambered panels to form a collapsible cell between a pair of adjacent diaphragms and the first and second cambered panels, only one bend being formed in each cambered panel between the pair of adjacent diaphragms.

19. The roadway crash cushion of claim 18 wherein the collapsible cells collapse longitudinally when a longitudinal force is applied to the roadway crash cushion.

20. The roadway crash cushion of claim 19 wherein the first and second cambered panels comprise a thermoplastic material operable to substantially return the first and second cambered panels to their initial form after the collapsible cells collapse.

21. The roadway crash cushion of claim 20 wherein the thermoplastic material comprises polyethylene.

22. The roadway crash cushion of claim 19 wherein each diaphragm engages at least one longitudinal, ground-mounted rail member to allow slidable movement of the diaphragms along the rail member as the collapsible cells collapse.

23. The roadway crash cushion of claim 19 wherein each diaphragm engages at least two longitudinal, ground-mounted rail members to allow slidable movement of the diaphragms along the rail member as the collapsible cells collapse.

24. The roadway crash cushion of claim 23 wherein each diaphragm comprises a pair of shoes for slidably engaging the rail members.

25. The roadway crash cushion of claim 18 wherein each of the first plurality of bends is located at a point on the first cambered panel that corresponds with a similar location on the second cambered panel.

26. The roadway crash cushion of claim 18 wherein each of the first plurality of bends are located at a point on the first cambered panel that corresponds with a midway point within an associated collapsible cell.

27. The roadway crash cushion of claim 18 further comprising a tension cable coupling at least two diaphragms, the tension cable operable to redirect a force applied perpendicularly to the first cambered panel.

28. The roadway crash cushion of claim 18 further comprising a nose piece configured to receive a longitudinal force, a first end of the nose piece coupled to the first cambered panel, a second end of the nose piece coupled to the second cambered panel.

29. The roadway crash cushion of claim 18 wherein the array of collapsible cells comprise:

a first cell of a first size; and  
a second cell of a second size, the second size smaller than the first size, the second cell downstream from the first cell.

30. The roadway crash cushion of claim 18 wherein the array of collapsible cells comprise:

a first plurality of cells, each of the first plurality of cells of a first size; and

a second plurality of cells, each of the second plurality of cells of a second size, the second size smaller than the first size, the second plurality of cells downstream from the first plurality of cells.

31. A roadway crash cushion, comprising:  
a collapsible cushion portion comprising:

a first panel member including a plurality of bends in the panel, the first panel configured to collapsibly fold during a collision and, due to shape memory, substantially return to an unfolded condition following a collision; and

a second panel member including a plurality of bends in the panel, the first panel configured to collapsibly fold during a collision and, due to shape memory, substantially return to an unfolded condition following a collision, the second panel substantially parallel to the first panel and spaced apart from the first panel such that a plurality of collapsible and substantially self-restoring cells are formed between the first and second panels,

wherein each collapsible and substantially self-restoring cell is formed between a pair of adjacent supporting frames and the first and second panel members, only one bend being formed in each panel member between the pair of adjacent supporting frames.

32. The roadway crash cushion of claim 31, wherein the collapsible cells collapse longitudinally when a longitudinal force is applied to the roadway crash cushion.

33. The roadway crash cushion of claim 32, wherein the first and second panel members comprise a thermoplastic material operable to substantially return the first and second panel members to their initial form after the collapsible cells collapse.

34. The roadway crash cushion of claim 33, wherein the thermoplastic material comprises polyethylene.

35. The roadway crash cushion of claim 32, wherein the pair of adjacent supporting frames comprise a pair of diaphragms, and wherein each diaphragm engages at least one longitudinal, ground-mounted rail member to allow slidable movement of the diaphragms along the rail member as the collapsible cells collapse.

36. The roadway crash cushion of claim 32, wherein the pair of adjacent supporting frames comprise a pair of diaphragms, and wherein each diaphragm engages at least two longitudinal, ground-mounted rail members to allow slidable movement of the diaphragms along the rail member as the collapsible cells collapse.

37. The roadway crash cushion of claim 36, wherein each diaphragm comprises a pair of shoes for slidably engaging the rail members.

38. The roadway crash cushion of claim 31, wherein each bend is located at a point on the first panel member that corresponds with a similar location on the second panel member.

39. The roadway crash cushion of claim 31, wherein each bend is located at a point on the first panel member that corresponds with a midway point within an associated collapsible cell.

40. The roadway crash cushion of claim 31, further comprising:

a tension cable coupling at least two diaphragms the pair of adjacent supporting frames, the tension cable operable to redirect a force applied perpendicularly to the first panel member.

41. The roadway crash cushion of claim 31, further comprising a nose piece configured to receive a longitudinal force,

9

a first end of the nose piece coupled to the first panel member, a second end of the nose piece coupled to the second panel member.

42. The roadway crash cushion of claim 31, wherein the second panel is spaced apart from the first panel such that an array of collapsible cells is formed between the first and second panels, the array of collapsible cells comprising:

a first cell of a first size; and

a second cell of a second size, the second size smaller than the first size, the second cell downstream from the first cell.

10

43. The roadway crash cushion of claim 31, wherein the second panel is spaced apart from the first panel such that an array of collapsible cells is formed between the first and second panels, the array of collapsible cells comprising:

a first plurality of cells, each of the first plurality of cells of a first size; and

a second plurality of cells, each of the second plurality of cells of a second size, the second size smaller than the first size, the second plurality of cells downstream from the first plurality of cells.

\* \* \* \* \*