



US006356351B1

(12) **United States Patent**  
**Blake**

(10) **Patent No.:** US **6,356,351 B1**  
(45) **Date of Patent:** \***Mar. 12, 2002**

(54) **FIBER-OPTIC CURRENT SENSOR WITH IMPROVED ISOLATION**

(75) Inventor: **James N. Blake**, Scottsdale, AZ (US)

(73) Assignee: **The Texas A&M University System**,  
College Station, TX (US)

(\*) Notice: Subject to any disclaimer, the term of this patent is extended or adjusted under 35 U.S.C. 154(b) by 0 days.

This patent is subject to a terminal disclaimer.

(21) Appl. No.: **09/731,189**

(22) Filed: **Dec. 6, 2000**

**Related U.S. Application Data**

(63) Continuation of application No. 09/275,491, filed on Mar. 24, 1999.

(51) **Int. Cl.**<sup>7</sup> ..... **G01B 9/02**

(52) **U.S. Cl.** ..... **356/483**

(58) **Field of Search** ..... 356/477, 479, 356/483; 250/227.19, 227.27, 227.17; 324/96

(56) **References Cited**

U.S. PATENT DOCUMENTS

5,644,397 A \* 7/1997 Blake ..... 356/483

\* cited by examiner

*Primary Examiner*—Samuel A. Turner

(74) *Attorney, Agent, or Firm*—Baker Botts L.L.P.

(57) **ABSTRACT**

A current sensor coil design for reducing or eliminating long undulations of magnetic sensitivity. Such reduction or elimination improves isolation of the current sensor such that proximate currents and accompanying effects do not affect the accuracy of the current sensor determination of a current being measured. Several designs, which may be incorporated separately or in combination, include modifying the specifications of the quarter waveplate, cutting the fiber of the sensor coil to a proper length, choosing a proper perimeter length of the sensor coil or head, and using a particular length of fiber adjusted to work in conjunction with a multi-wavelength or broadband light source.

**14 Claims, 4 Drawing Sheets**

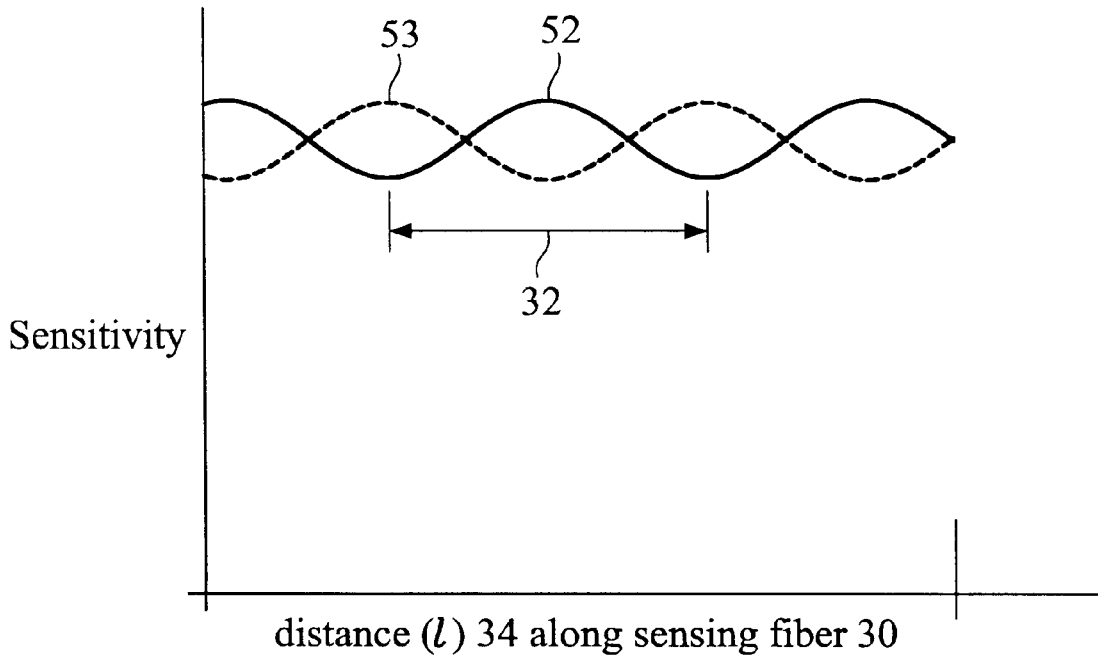

FIG. 1  
(PRIOR ART)

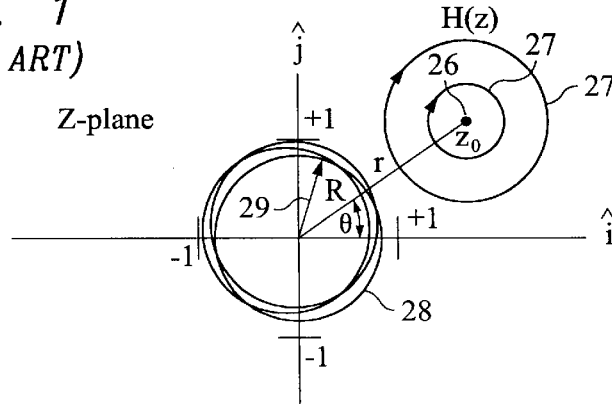

FIG. 2  
(PRIOR ART)

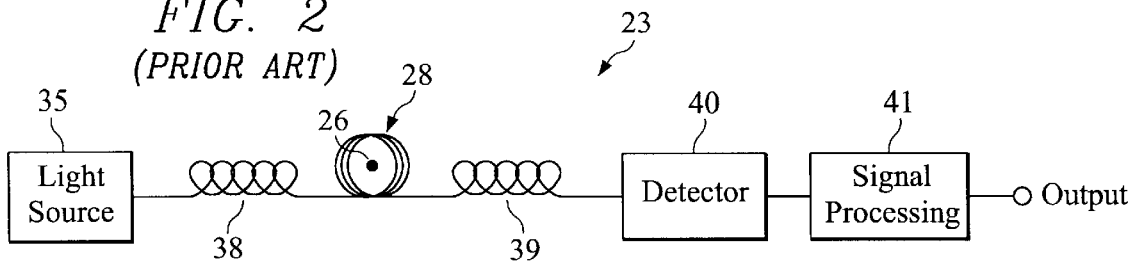

FIG. 3  
(PRIOR ART)

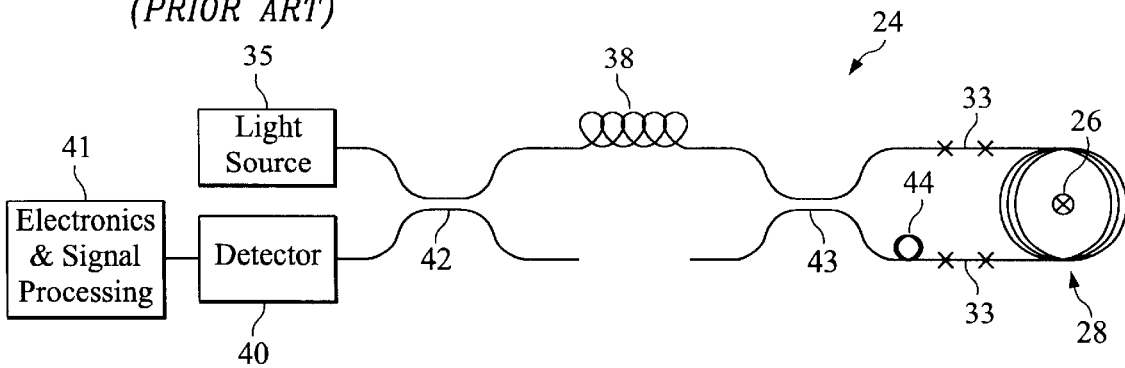

FIG. 4  
(PRIOR ART)

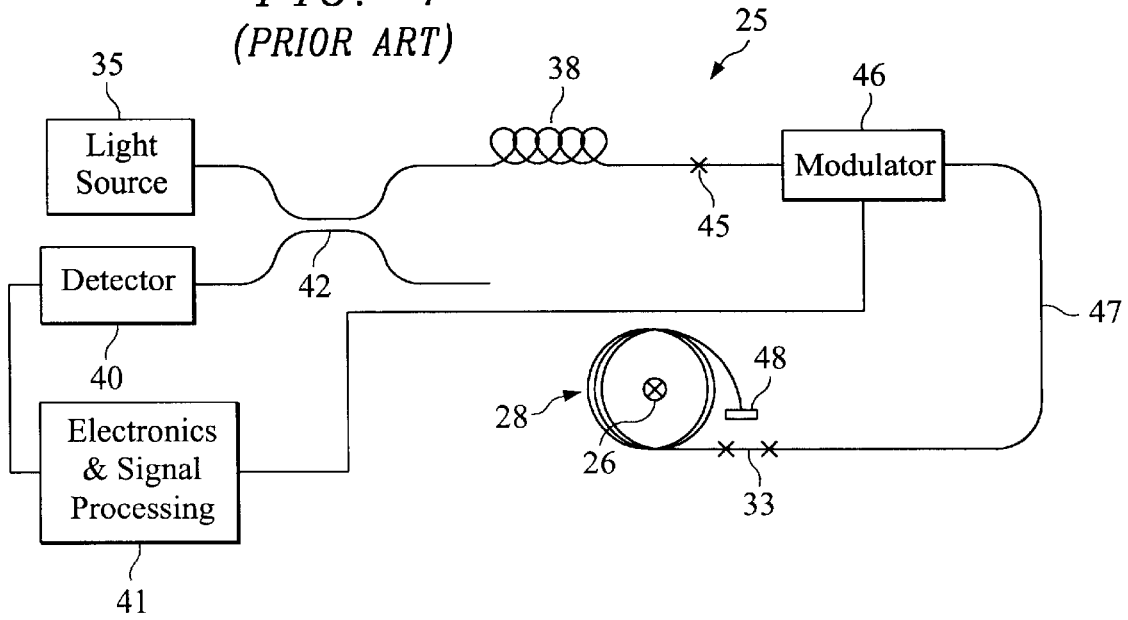

FIG. 5

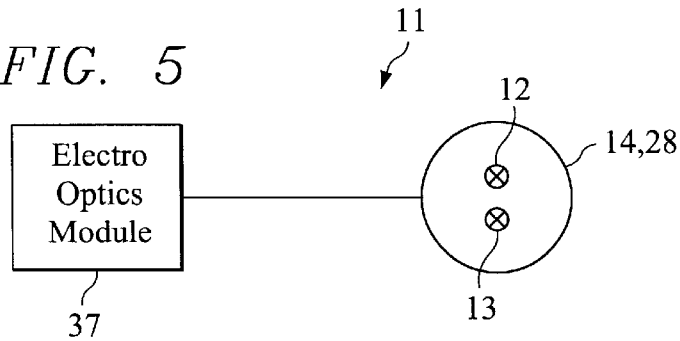
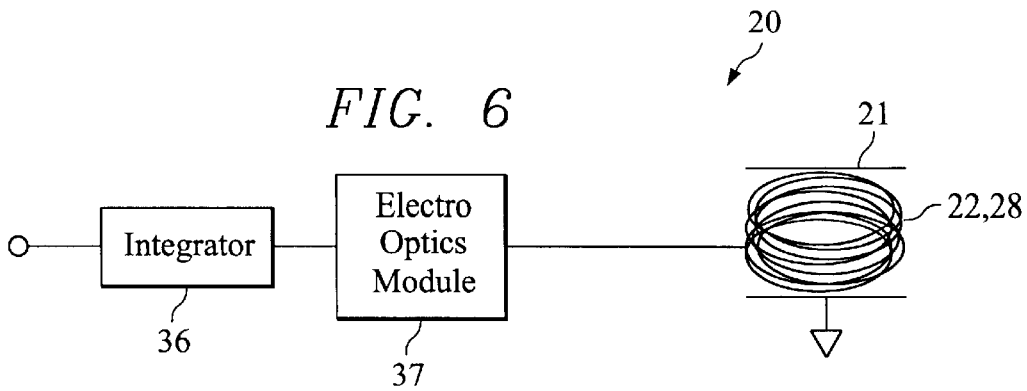

FIG. 6



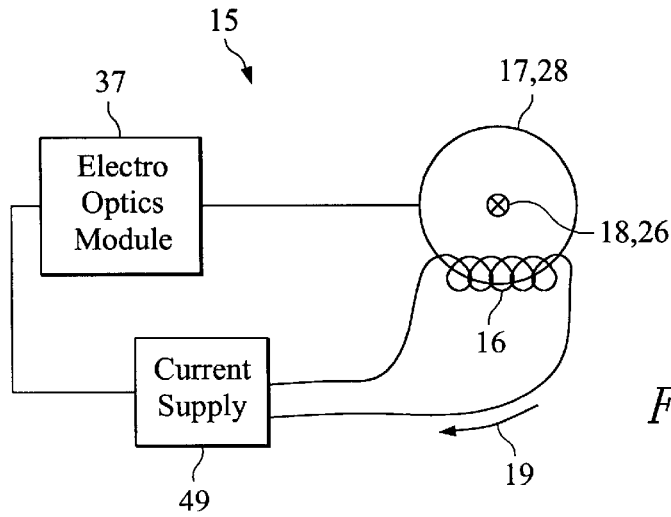

FIG. 7

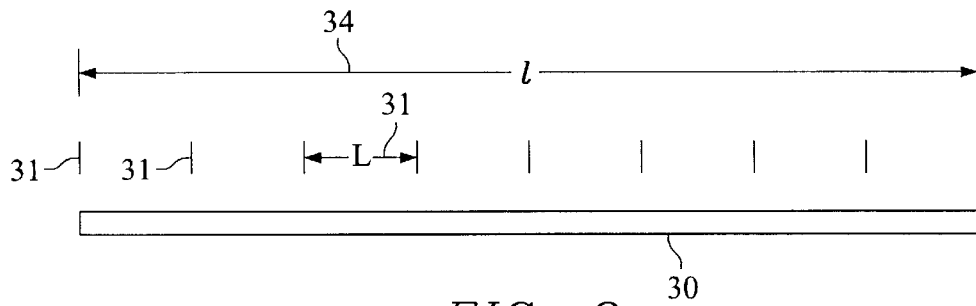

FIG. 8

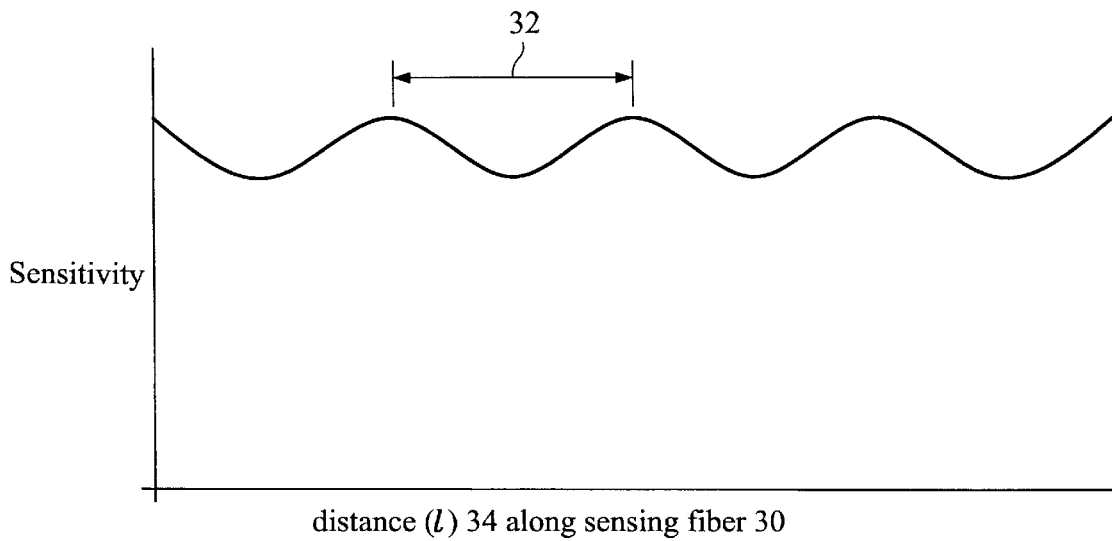

FIG. 9

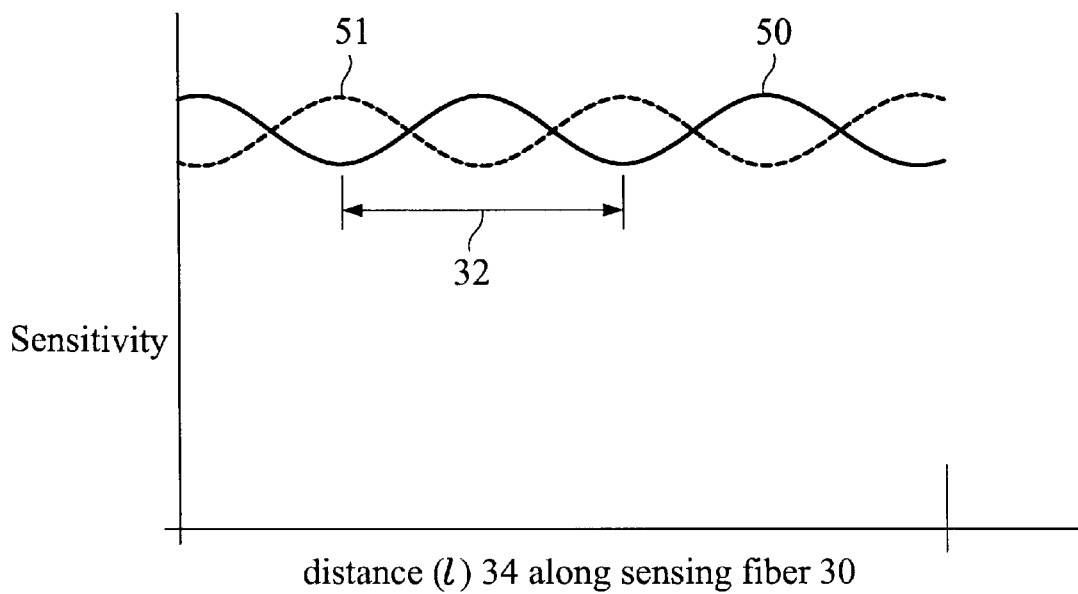

FIG. 10

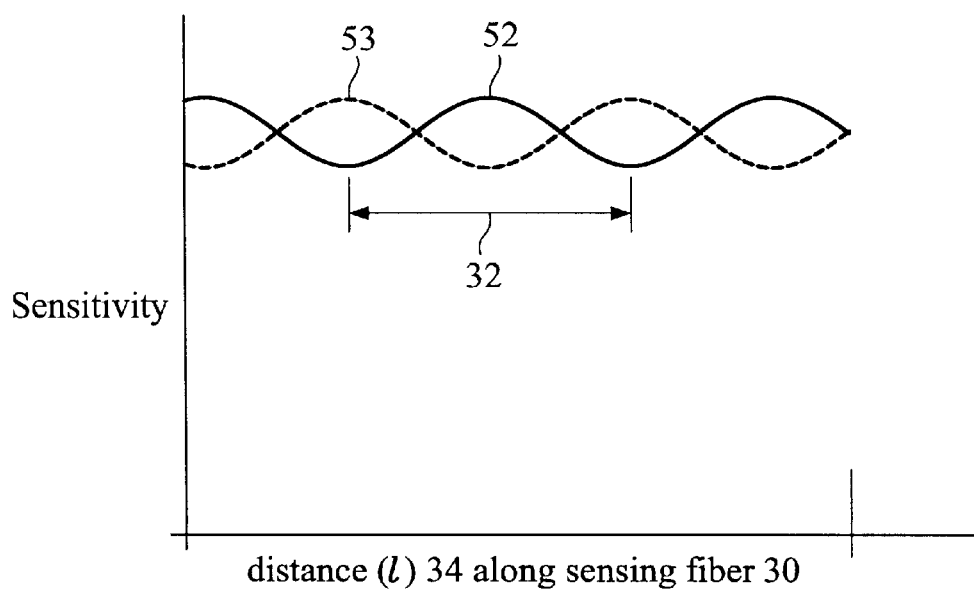

FIG. 11

## FIBER-OPTIC CURRENT SENSOR WITH IMPROVED ISOLATION

This application is a continuation of U.S. application Ser. No. 09/275,491 filed Mar. 24, 1999 still pending.

### BACKGROUND

The invention pertains to current sensors and particularly to fiber optic current sensors. More particularly, the invention pertains to fiber optic current sensors having improved isolation.

Fiber optic current sensors operate on the principle that the magnetic field produced by an electrical current affects certain properties of the light contained in an optical fiber wound around the current carrying conductor. Through the Faraday effect, those properties affected can be either the polarization state of the light (polarimetric type sensor) or the velocity of the light (interferometric type sensor). Through Ampere's law,

$$\oint H \cdot dl = I, \quad (1)$$

it is evident that for the current sensor to make an accurate determination of the current, I, the light in the fiber should be uniformly and linearly sensitive to the magnetic field, H, and the sensitive region should comprise as perfectly a closed path as possible. In this case, the sensor substantially measures  $\oint H \cdot dl$ , thereby giving an indication of I as an output, provided that the sensor is well isolated against currents flowing outside the sensing loop. In addition, the sensor should return the correct value of I regardless of the actual location of the current flowing through the sensing coil.

A number of applications for current sensing exist which require the sensor to exhibit an extremely good isolation from external currents as well as extremely uniform response to currents that pass through the sensing coil at different physical locations. For example, a ground fault interrupter for large currents may have a difference current measurement system **11** with a sensor coil or head **14** that encloses both the outgoing **12** and return **13** currents (FIG. **5**). Hundreds of amperes of current may flow through the wires, while a difference between the two currents **12** and **13** of a few milliamperes should be quickly recognized. Such a system may exist in the vicinity of many other conductors carrying hundreds of amperes of current. The isolation of sensor head **14** to external currents should therefore be better than ten parts-per-million, and sensor system **11** should respond uniformly to the outgoing and return currents to within ten parts-per-million.

A second example of how a fiber optic current sensor may advantageously benefit from good isolation/uniformity performance is the construction of a fiber optic current sensor **15** assisted current transformer **16** (FIG. **7**). In this device, fiber optic current sensor **15** is operated using a secondary current **19** from current supply **49** to null the output (i.e., close the loop). A current **18** to be measured passes through a sensing coil or head **17**, while an equal and opposite loop closing current **19** passes through the sensing coil **16**, possibly through multiple turns. Loop closing current **19** includes the secondary of this fiber optic current sensor **15** assisted current transformer. The accuracy of this device depends on current sensor **15** exhibiting uniform response to currents passing therethrough for all the different physical locations of current **18**.

A third example of a fiber optic current sensor requiring superior isolation is the displacement current based voltage

sensor **20** (FIG. **6**). In this device, an AC voltage **21** is measured by integrating (by integrator **36** via electro-optics module **37**) the output of a current sensor head **22** that responds to displacement current. Typically, sensor **20** might measure a few milliamperes of displacement current. The power line, which carries voltage **21** to be measured, may also carry a real current, which might typically be a few thousand amperes. Thus, to obtain a true measure of the voltage, it is necessary for the current sensor head **22** to be well isolated from the real current flowing through the power line. The isolation requirement for this application may easily exceed one part-per-million.

A problem with Faraday effect based optical current sensors, both polarimetric **23** (FIG. **2**) and interferometric **24, 25** (FIGS. **3** and **4**), is that the sensitivity of the light to the local magnetic field depends on the exact polarization state of the light at that point. It is very difficult to maintain a strictly uniform state of polarization of the light throughout a sensing path of the sensing head or coil, as stresses within the glass induce local birefringences that alter the polarization state of the light. Thus, a method of desensitizing the sensor head to these imperfections is needed in order to achieve the overall intended isolation and uniformity requirements.

### SUMMARY OF THE INVENTION

It has been discovered that maintaining an unaltered polarization state of the light throughout the sensing loop(s) is not a practical necessity to achieve superior isolation and uniformity performance of the sensor. Rather, a sufficient requirement on the sensor head or coil for achieving good isolation and uniformity is that it not exhibit long period undulations in sensitivity. Undulations having long periods reduce isolation of the sensor head so as to be sensitive to other currents not intended to be measured. Accordingly, set forth here are design approaches for fiber optic current sensors that reduce long period undulations in the sensitivity of the sensing head coil. Remaining rapid undulations contribute negligibly to uniformity and isolation errors.

### BRIEF DESCRIPTION OF THE DRAWING

FIG. **1** shows the geometry of an electrical current, its associated magnetic field, and an optical current sensor coil.

FIG. **2** shows a polarimetric fiber optic current sensor.

FIG. **3** shows a Sagnac loop type fiber optic current sensor.

FIG. **4** shows an in-line interferometric type fiber optic current sensor.

FIG. **5** shows a fiber optic current sensor for measuring small differences between two large currents.

FIG. **6** shows a displacement current-based voltage sensor.

FIG. **7** shows a fiber optic current sensor assisted current transformer.

FIG. **8** shows a depiction of an optical fiber having a periodic structure used for making a fiber optic current sensing coil.

FIG. **9** shows the sensitivity of a fiber optic current sensing coil as a function of distance along the sensing fiber.

FIG. **10** shows the direction dependent sensitivity along the sensing coil for a Sagnac loop type fiber optic current sensor having an optimal length of sensing fiber.

FIG. **11** shows the direction dependent sensitivity of the sensing coil for an in-line interferometric type fiber current sensor having an optimal length of sensing fiber.

## DESCRIPTION OF THE PREFERRED EMBODIMENT

For a complex plane  $Z$ , vector notation is  $z=ix+jy$  and scalar notation is  $z=x+iy$ . Vector quantities are typed in boldface. As shown in FIG. 1, a current **26**,  $I$ , flows perpendicular into the complex plane  $Z$  in the  $k$  direction at coordinate position  $z_0$ . The magnetic field **27**,  $H$ , at position  $z$  associated with flowing current **26** is given by,

$$H = \frac{I}{2\pi} k \times \frac{(z - z_0)}{|z - z_0|^2} \quad (2)$$

$$= \frac{I}{2\pi|z - z_0|^2} \{-i(y - y_0) + j(x - x_0)\}$$

A fiber current sensor head **28** measures

$$I_{sensed} = \oint S(z) H \cdot dz, \quad (3)$$

where  $S(z)$  is the relative sensitivity of sensor head **28** at position  $z$ . Ideally,  $S(z)=1$  for all  $z$ , i.e., sensor head **28** uniformly responds to magnetic field **27** all along its sensing path. Substituting equation (1) into equation (2) one finds that

$$I_{sensed} = \frac{I}{2\pi} \oint \frac{S(z)}{|z - z_0|^2} \{-i(y - y_0)dx + (x - x_0)dy\}. \quad (4)$$

Using the relations

$$x - x_0 = \frac{1}{2}(z - z_0 + z^* - z_0^*); \quad dx = \frac{1}{2}(dz + dz^*) \quad (5)$$

and

$$y - y_0 = \frac{1}{2i}(z - z_0 - z^* + z_0^*); \quad dy = \frac{1}{2i}(dz - dz^*), \quad (6)$$

equation (4) is found to be

$$I_{sensed} = \text{Re} \left[ \frac{I}{2\pi i} \oint \frac{\text{Re}[S(z)]}{z - z_0} dz \right] - \frac{I}{2\pi i} \text{Im} \left[ \oint \frac{\text{Im}[S(z)]}{z - z_0} dz \right]. \quad (7)$$

For all real problems,  $\text{Im}[S(z)]$  must vanish along the path of integration, since the sensitivity must ultimately be a real valued function along the sensing fiber (though it need not be real valued elsewhere). Consequently, the second integral in equation (7) is zero, and  $\text{Re}[S(z)]$  can be replaced by  $S(z)$  in the first integral. Thus, one has the general result that for real sensor heads,

$$I_{sensed} = \text{Re} \left[ \frac{I}{2\pi i} \oint \frac{S(z)}{z - z_0} dz \right]. \quad (8)$$

From equation (8), one can see that current **26** at position  $z_0$  creates a single pole at that point. This corresponds to the physical pole in magnetic field **27** associated with the assumed infinitely thin current flow. For the ideal case that  $S(z)=1$ , equation (8) is solved using the residue theorem to yield  $I_{sensed}=I$  when the path of integration encloses current **26** (i.e., the path integral encloses the pole at  $z_0$ ), and  $I_{sensed}=0$  when the path of integration does not enclose current **26**.

For mathematical simplicity, one now makes the assumption that fiber sensor head **28** lies on the unit circle in the

complex plane. Thus, sensor head **28** encloses current **26** carrying wire if  $|z_0|<1$ , and sensor head **28** does not enclose current **26** if  $|z_0|>1$ . The results that follow from this assumption apply exactly to the case of a fiber current sensor with a circular sensing head; however, the principles derived apply also to the case of a "non-circular" sensing head. For example, one could have a square or oval winding as part of sensor head **28**. The isolation and uniformity imperfections derived apply to all types of optical current sensors that operate by integrating the magnetic field.

Particular implementations of fiber optic current sensors include a polarimetric current sensor **23** in FIG. 2, a Sagnac loop current sensor **24** in FIG. 3, and an in-line interferometric current sensor **25** in FIG. 4.

In sensor **23**, source **35** outputs light that goes through polarizer **38**, the optical fiber coil of sensor head **28**, and analyzer **39**. Magnetic field **27** of current **26** affects the polarization of the light. This change is noted by detector **40**. The output of detector **40** goes to electronics and signal processor **41**.

In sensor **24**, source **35** outputs light through coupler **42** and polarizer **38**. The light is split by coupler **43** into counterpropagating beams for sensor head **28**. The light beams go through quarter waveplates, for conversion to circular polarization and vice versa upon their return to coupler **43**. A bias modulation signal from electronics **41** applied to the light by modulator **44**. The returning beams go through coupler **43** and polarizer **38** to detector **40**. Magnetic field **27** of current **26** affects a phase relationship which is noted at detector **40**. The electrical output of detector **40** goes to electronics and signal processor **41**.

In sensor **25**, source **35** outputs light through coupler **42**, polarizer **38** and 45-degree splice **45** to modulator **46**. The output light of modulator **46** goes through fiber delay line **47** and quarter waveplate **33** to an optical fiber coil of sensor head **28**. The light is reflected back by mirror **48** back through the fiber coil of sensor head **28**, quarter waveplate polarization converter **33** and delay line **47** to modulator **46**. The light going back from modulator **46** goes through splice **45**, polarizer **38** and coupler **42** to detector **40**. Magnetic field **27** of current **26** affects the phase relationship of the entering light and returning light of sensor head **28**, which is noted at detector **40**. The electrical output from detector **40** goes to electronics and processor **41**.

This technology is related to the in-line optical fiber current sensor as disclosed in U.S. Pat. No. 5,644,397 issued Jul. 1, 1997, to inventor James N. Blake and entitled "Fiber Optic Interferometric Circuit and Magnetic Field Sensor", which is incorporated herein by reference. Optical fiber sensors are also disclosed in U.S. Pat. No. 5,696,858 issued Dec. 9, 1997, to inventor James N. Blake and entitled, "Fiber Optics Apparatus and Method for Accurate Current Sensing", which is incorporated herein by reference.

The Fourier components of the sensitivity function  $S(\theta)$  in polar coordinates on the unit circle are  $e^{in\theta}$  or  $e^{-in\theta}$  where  $n$  is an integer. The corresponding Fourier component representations in the complex  $Z$  plane are  $z^n$  and  $Z^{-n}$ .

The sensitivity function of a ring fiber sensor head **28** can be represented in polar coordinates as

$$S(\theta) = S_0 + \sum_{n=1} a_n e^{in\theta} + b_n e^{-in\theta} \quad (9)$$

## 5

or generalized in the Z plane as

$$S(z) = S_0 + \sum_{n=1} a_n z^n + b_n z^{-n}. \quad (10)$$

In these equations, one restricts the choices of  $a_n$  and  $b_n$  to satisfy the condition that  $S(z)$  is real valued on the unit circle of sensor head **28**. Substituting equation (10) into equation (8) and solving the integral using the residue theorem yields the general relationship between the sensed current and the real current. The results are

$$I_{sensed} = I \left[ S_0 + \operatorname{Re} \left( \sum_{n=1} a_n z_0^n \right) \right] \text{ for } |z_0| < 1 \quad (11)$$

and

$$I_{sensed} = -I \operatorname{Re} \left( \sum_{n=1} b_n z_0^{-n} \right) \text{ for } |z_0| > 1. \quad (12)$$

Equation (11) represents the scale factor, or uniformity error associated with the current **26** being offset from the middle of fiber sensing coil **28**, and equation (12) represents the isolation of the sensor to currents **26** passing outside sensing coil **28**.

A particularly important example to solve is that where the sensitivity function is given by  $S(\theta) = 1 + \epsilon \cos(n\theta)$ . As will be shown later, for the case that a sensing fiber **30** of sensor head **28** comprises a periodic structure, a long period undulation in the sensitivity of the fiber to magnetic fields exists. These long undulations ultimately limit the uniformity and isolation performance of the sensor.

The radius of sensing fiber coil **28** is taken to be  $R$ , and the current **26** carrying wire is taken to be located at the point  $(r, \phi)$  in polar coordinates. By solving equations (9) through (12), one finds the uniformity error due to a non-centered current to be given by

$$\frac{I_{sensed}}{I} - 1 = \frac{\epsilon}{2} \left( \frac{r}{R} \right)^n \cos(n\phi) \quad R > r, \quad (13)$$

while the isolation to currents outside sensing fiber loop **28** is given by

$$\frac{I_{sensed}}{I} = \frac{-\epsilon}{2} \left( \frac{R}{r} \right)^n \cos(n\phi) \quad r > R. \quad (14)$$

From these results one sees that higher order variations in the sensitivity of fiber sensor head **28** (corresponding to high values of  $n$ ) contribute negligibly small uniformity errors for nearly centered currents and negligibly small isolation errors for nearby current carrying wires any reasonable distance from the fiber sensor. However, long period undulations in the sensitivity (corresponding to low values of  $n$ ) give rise to significant errors and should be avoided in the optical design of the sensor head.

Both the Sagnac loop **24** and in-line interferometric **25** type current sensors operate on the principle that circularly polarized light waves propagate with different velocities in the presence of a magnetic field **27**. Thus, for these types of sensor implementations, one desires to launch and maintain circularly polarized light waves in the sensing fiber. One method for maintaining circularly polarized light waves in an optical fiber is to construct a fiber **30** using a periodic structure **31** (illustrated in FIG. **8**) with appropriate properties.

## 6

Sensing fiber **30** having a periodic structure **31** with lengths  $L$  may be modeled using a Jones matrix

$$\begin{pmatrix} A & B \\ -B^* & A^* \end{pmatrix} \quad (15)$$

to represent each period of the periodic structure. The associated eigenvalues,  $\lambda_{\pm}$ , for this matrix are given by

$$\lambda_{\pm} = e^{\pm j \arccos(\operatorname{Re}(A))} \quad (15)$$

and the associated eigenvectors,  $v_{\pm}$ , are given by

$$v_{\pm} = \begin{pmatrix} B \\ \lambda_{\pm} - A \end{pmatrix}. \quad (16)$$

Appropriate periodic structures for maintaining circular polarization are those for which  $v_{\pm}$  approximate right- and left-handed circular polarization states.

When light is launched into such a fiber **30**, the polarization state of the light will evolve with both rapid undulations (spatial harmonics of the period of the periodic structure) and a slow undulation (having a period much longer than the period of the periodic structure). FIG. **9** illustrates the fiber sensitivity having a long period undulation **32**. As shown above, the rapid undulations contribute negligibly to uniformity and isolation errors. Thus, the slow period **32** poses the biggest concern. For this fiber **30**, the slow period of polarization state evolution,  $\xi$ , is given by

$$\xi = L \frac{\pi}{\cos^{-1}[\operatorname{Re}(A)]}. \quad (17)$$

Here  $L$  is the length **31** of each period of the periodic structure.

For the case that sensing fiber **30** with a periodic structure comprises a bent-spun birefringent fiber, the long spatial period that exists has been found to be

$$\xi \approx 4L_B^2 / L_{rev}. \quad (18)$$

Here  $L_B$  is the intrinsic polarization beat length of the fiber in its unspun state, and  $L_{rev}$  is the distance over which the fiber is twisted by one revolution.  $L_{rev}$  is the length **31** of each period in the periodic structure of fiber **30**. The long spatial period,  $\xi$ , is independent of the bend radius as long as fiber **30** is not bent too severely. For a highly bent spun fiber,  $\xi$  becomes shorter. The amplitude of this low frequency deviation of the polarization away from circular polarization increases with increasing bend birefringence (due to tighter bending). As a numerical example, a fiber **30** having an unspun beat length of  $L_B = 3$  centimeters (cm), and a spin rate of  $L_{rev} = 5$  millimeters (mm) will exhibit a periodic variation in sensitivity to magnetic fields with a period of approximately 72 cm.

As the light propagates down the fiber, the light oscillates in and out of the pure circular polarization state. For minimizing the power that leaves the desired circular state of polarization, it is important to optimize the ratio of the spin rate to the intrinsic polarization beat length of the fiber. If the spin rate is too fast, the intrinsic birefringence of the fiber is too well averaged and the fiber becomes very sensitive to bend induced birefringence. If the spin rate is too slow, the intrinsic birefringence is not well averaged, and the fiber does not hold a circular state of polarization for this reason. Numerical modeling of the characteristics of a bent spun



birefringent fiber yields the result that for practical bend radii (2 to 10 cm) the optimum ratio of the spin rate to the intrinsic beat length is between 4 and 6. Minimum degradation of the circular polarization holding capability is achieved when the ratio is between 3 and 8. By choosing a fiber with a spin rate in this range, the circular polarization state of the fiber can be maintained for a long length of fiber allowing for the sensitivity of the sensor to be greatly increased.

Eigen vectors,  $v_{\pm}$ , represent those polarization states that repeat after each period **32** along the distance  $l$  **34** of the periodic structure **31** of fiber **30**. By launching the interfering waves into the exact eigen vector polarization states of the sensing fiber, slow period **32** of the polarization state evolution is nulled. Substantially matching the launched polarization state to the eigen vectors of the periodic structure of the sensing fiber constitutes a first method of overcoming slow or long undulations **32**. For the in-line **25** and Sagnac **24** type current sensors which use spun-birefringent sensing fiber **30**, one may change a (nominal) quarter waveplate **33** slightly such that the light that is launched into the sensing fiber is of that polarization state that maintains itself upon propagation along the sensing fiber. That is, for a quarter waveplate **33** having a length of 3 cm and angle of 45 degrees, a slightly changed quarter waveplate **33** would be at 2.8 cm and 42 degrees, to avoid long undulation. For the bent-spun fiber, this "eigen polarization state" is equal to that state which repeats itself after propagating a distance corresponding to one complete revolution of fiber twist.

A second method for overcoming this slow undulation **32** in the fiber sensitivity to-magnetic fields **27** is to cut the overall length of the sensing fiber **30** to a proper length  $l$  **34**. For a double-pass device using a reflective termination **48** such as a in-line type **25** sensor head **28**, this proper length is  $M\xi/4$ , where  $M$  is an odd integer. For the Sagnac loop type sensor **24**, a proper length **31** is  $M\xi/2$ , where  $M$  is an odd integer. These length **31** choices cause the low-order variation of the magnetic field sensitivity as seen by the light traveling in one direction to be cancelled by the light traveling in the opposite direction. FIGS. **10** and **11** show the direction dependent local sensitivities of the sensing fiber **30** to magnetic field for the Sagnac and in-line sensors, respectively.

FIG. **10** shows the magnetic field sensitivity versus distance  $l$  **34** along fiber **30** of sensing coil **28** for Sagnac loop interferometric type fiber optic current sensor **24**, having an optimal fiber **30** length,  $L_{total}$ .  $L_{total}$  is equal to  $M\xi/2$  where  $M$  is an odd integer and  $\xi$  is the length of long period undulation **32**. Curve **50** shows the sensitivity in the first direction of fiber **30** of coil **28**. Curve **51** shows the sensitivity in the second direction of fiber **30**. The effects of these sensitivities cancel each other.

FIG. **11** shows the magnetic field sensitivity versus distance  $l$  **34**, along fiber **30** of sensing coil **28**, for in-line interferometric type fiber optic current sensor **25**, having an optimal fiber **30** length,  $L_{total}$ .  $L_{total}$  is equal to  $M\xi/4$ , where  $M$  is an odd integer and  $\xi$  is the length of long period undulation **32**. Curve **52** shows the sensitivity in the first direction of fiber **30** in sensing head **28**. Curve **53** shows the sensitivity in the second direction of fiber **30**. The effects of these sensitivities cancel each other.

A third method for canceling this slowly varying sensitivity is to form a sensing coil **28** using multiple turns of sensing fiber **30** having a properly chosen perimeter length  $P$ . The perimeter of sensing coil **28** should be chosen to be such a length that the slow variations in sensitivity are averaged out over the whole sensing coil. Mathematically, this idea is developed as follows.

The local sensitivity of the sensing fiber to magnetic field along the length  $l$  **34** of fiber **30**,  $S(l)$  is written as (excluding high spatial frequency variations),

$$S(l) = S_0 + S_1 \cos\left(\frac{2\pi l}{\xi} + \psi\right), \quad (19)$$

where  $S_0$  is the constant part or characteristic of the sensitivity,  $\xi$  is the long period of undulation in the polarization state of the light and  $\psi$  is a phase offset.  $S_0$  should not be confused with  $S_1$ ,  $S_2$ , etc., which represent imperfections of coil **28**. When a multi-turn optical fiber sensing coil **28** is used, one desires that the sum of the local sensitivities at each point at length  $l$  along the fiber length **34** in the sensing coil **28** accumulate to a constant. Thus, one requires that

$$\sum_{n=1}^{N-1} \cos\left(\frac{2\pi n l}{\xi} + \psi\right) = 0, \quad \text{for all } l, \quad (20)$$

where  $P$  is a perimeter length around the sensing coil and not the length of the sensing fiber,  $N$  is the total number of turns of fiber comprising sensing coil **28**, and  $n$  is the index of summation for all fibers at that point of  $nP$ .  $l$  is a distance along the length of the fiber.  $S_n$  represents the imperfections of coil **28**. Ideally,  $S_n$  should be zero. Besides  $S_0$ , only  $S_1$  and  $S_2$  are of most concern.  $S_3$ ,  $S_4$  and so forth are generally insignificant. The varying sensitivity around a perimeter of sensing coil **28** may be stated as

$$S_0 + \sum_{n=1}^{\infty} S_n \cos\left(\frac{2n\pi z'}{P} + \varphi_n\right), \quad (21)$$

where  $z'$  is a distance along the perimeter  $P$  of sensing coil **28**, and  $\varphi_n$ 's are constants.  $S_1$  and  $S_2$  are typically less than  $S_0 \cdot 10^{-3}$ .

The requirement of equation (20) can be simplified to yield,

$$\frac{\sin\left(\frac{\pi NP}{\xi}\right)}{\sin\left(\frac{\pi P}{\xi}\right)} = 0, \quad (22)$$

or

$$P = \frac{m\xi}{N}, \quad (23)$$

where  $m$ =odd integer, excluding  $m=kN$ ,  $k$ =any integer. Thus, by choosing the perimeter of sensor coil **28** to substantially meet the requirement imposed by equation (23), the overall sensitivity variation having a period  $\xi$  is canceled over the entire sensing coil.

A fourth method for overcoming the deleterious effects on isolation and uniformity performance of a slow undulation **32** in the magnetic field **27** sensitivity is to use a long length  $l$  **34** of sensing fiber **30** in combination with a multi-wavelength, or broad band light source **35**. The periods of slow undulations **32** in the sensing fiber **30** are typically wavelength dependent. For the bent-spun fiber **30**, the period of slow undulation **32** is proportional to wavelength squared. By employing a light source **35** with multiple wavelengths,

the corresponding multiple periods of sensitivity will eventually cause the sensitivity to average to a constant after a long distance **34** (l) of sensing fiber **30**. For fiber sensor coil **28** lengths greater than the slow undulation period **32** divided by the fractional bandwidth of light source **35**, significant averaging of the slow undulation will occur. Mathematically, this condition is expressed as

$$L_{total} > \frac{\xi\lambda}{\Delta\lambda}, \tag{24}$$

where  $L_{total}$  is the total length **34** of sensing fiber **30**,  $\lambda$  is the mean source **28** wavelength, and  $\Delta\lambda$  is the wavelength spread of the source. Typically,  $L_{total}$  would need to exceed several tens of meters for this technique to yield significant results.

These four methods for overcoming the deleterious effects on isolation and uniformity performance of a slow undulation **32** in the fiber **30** sensitivity to magnetic field **27** are complementary. They may be implemented either separately, or in any combination.

Though the invention has been described with respect a specific preferred embodiment, many variations and modifications will become apparent to those skilled in the art upon reading the present application. It is therefore the intention that the appended claims be interpreted as broadly as possible in view of the prior art to include all such variations and modifications.

I claim:

**1.** A magnetic field integrating optical sensor comprising:

a sensor head for providing an optical sensing light path which circumscribes an area having a perimeter P, and where said optical sensing light path has a length L and circumscribes said area N revolutions, and where sensor head sensitivity of period  $\xi$  to said magnetic field is of the form mathematically described by:

$$S_0 + \sum_{n=1}^{\infty} S_n \cos\left(\frac{2n\pi z'}{P} + \psi_n\right); \text{ and}$$

wherein:

$S_0$  is a sensitivity constant of said sensor head;  
each  $S_n$  is an imperfection constant of said sensor head, for  $n \geq 1$ ;

$z'$  is a distance along the perimeter P of said sensor head; and

each  $\psi_n$  is a constant; and said perimeter P is equal to

$$\frac{m \cdot \xi}{N},$$

where m is an odd integer not equal to kN and k is any integer.

**2.** The sensor of claim **1**, wherein said sensor head comprises a fiber-optic sensing coil.

**3.** The sensor of claim **2**, wherein the said fiber-optic sensing coil comprises a fiber having a periodic structure.

**4.** The sensor of claim **3**, wherein the fiber having a periodic structure is a spun birefringent fiber.

**5.** A magnetic field integrating fiber optic sensor comprising:

a sensor head including a sensing length of fiber, L, having a spatial periodic structure having a known spatial period of periodicity and characterized by,

sensitivity undulation along said sensing length of fiber, L, and

eigen vectors representative of those eigen polarization states that periodically repeat along said length of fiber at said known spatial period; and

a means for launching at least one light wave into said fiber having at least one polarization state that substantially matches one of said eigen vector polarization states of said fiber, such that any amplitude of sensitivity undulation is reduced.

**6.** The sensor of claim **5**, wherein the fiber having a periodic structure is a spun birefringent fiber having a repeating fiber twist.

**7.** The sensor of claim **6**, wherein said eigen polarization state is substantially that polarization state that repeats itself after propagating a distance along said fiber corresponding to one complete revolution of said fiber twist.

**8.** A method of minimizing sensitivity variation in a magnetic field integrated fiber optic sensor having a sensor head including a length of optical fiber having a periodic structure, wherein said optical fiber includes an input port for receiving an input light wave, said method comprising:

determining the eigen vectors representative of those eigen polarization states that periodically repeat along said length of optical fiber; and

coupling a polarized light wave into said optical fiber input port such said polarized light wave is oriented to substantially match said eigen polarization states.

**9.** A method of minimizing sensitivity variation in a magnetic field integrating fiber optic sensor having a sensor head including an optical sensing light path which circumscribes an area having a perimeter P, and where said optical sensing light path includes a sensing fiber having a length L and circumscribes said area N revolutions, the method comprising:

determining a slow undulation period  $\xi$  of said sensing fiber; and

selectively setting said perimeter P, and said sensing fiber length L such that sensitivity errors due to slow undulation period is minimized.

**10.** The method of claim **9** wherein perimeter P is substantially equal to

$$\frac{m \cdot \xi}{N},$$

where m is an odd integer not equal to kN; k is any integer; and N is a number of sensing fiber turns contained in the sensor head.

**11.** The method of claim **9** wherein said sensor forms, in part, a in-line interferometer, and is substantially equal to an odd integer times a quarter-period of the undulation.

**12.** The method of claim **9** wherein said sensor forms, in part, a sagnac interferometer, and said total fiber length L is substantially equal to an odd integer times a half-period of the undulation.

**13.** The method of claim **9** wherein:

said sensor includes a light source that emits multiple wavelengths; and

said total fiber length L is greater than the ratio of the undulation period to the fractional light source spectral bandwidth such that L is substantially equal to

$$\left(\frac{\xi \cdot \lambda}{\Delta \lambda}\right)$$

where  $\lambda$  is the mean source wavelength, and  $\Delta \lambda$  is the wavelength spread of the source.

14. A magnetic field integrating optical sensor comprising:

- a light source for generating an optical beam;
- a sensor head for providing an optical path such that said light beam may enter a first port, the sensor head circumscribing an area having a perimeter P, and where said optical path has a length L and circumscribes said area N revolutions, and where sensor head sensitivity of period  $\xi$  to said magnetic field is of the form mathematically described by:

$$S_0 + \sum_{n=1}^{\infty} S_n \cos\left(\frac{2n\pi z'}{P} + \psi_n\right); \text{ and}$$

wherein:

- $S_0$  is a sensitivity constant of said sensor head;
  - each  $S_n$  is an imperfection constant of said sensor head, for  $n \geq 1$ ;
  - $z'$  is a distance along the perimeter P of said sensor head; and
  - each  $\psi_n$  is a constant; and
- said perimeter P is equal to

$$\frac{m \cdot \xi}{N},$$

where m is an odd integer not equal to kN and k is any integer.

\* \* \* \* \*

UNITED STATES PATENT AND TRADEMARK OFFICE  
**CERTIFICATE OF CORRECTION**

PATENT NO. : 6,356,351 B1  
DATED : March 12, 2002  
INVENTOR(S) : James N. Blake

Page 1 of 1

It is certified that error appears in the above-identified patent and that said Letters Patent is hereby corrected as shown below:

Column 3,

Line 4, after "is", delete "z=x+iy).", and insert -- z=x+iy. --.

Column 7,

Line 16, delete "ture.of", and insert -- ture of --.

Line 30, after "sensitivity", delete "to-", and insert -- to --.

Line 53, after "coil 28" delete ",".

Column 9,

Line 29, after "1.", delete "An", and insert -- A --.

Column 10,

Line 57, after "part,", delete "a", and insert -- an --.

Signed and Sealed this

Tenth Day of December, 2002

A handwritten signature in black ink, appearing to read "James E. Rogan", written over a horizontal line.

JAMES E. ROGAN  
*Director of the United States Patent and Trademark Office*