



Case study

Fluctuation of Seal Gas Supply Differential Pressure of Dry Gas Seals

Abu Bakar Usman Niazi

Rotating Equipment Engineer
Qatargas Operating Company



Muhammad Zahid

Sr. Rotating Equipment Engineer
Qatargas Operating Company



The World's Premier LNG Company

قطر غاز
QATARGAS

Outline of Case Study

- Problem statement
- Compressor service overview
- Description of sealing system
- Problem description
- Troubleshooting
- Findings
- Remedial Actions
- Result
- Q & A

Problem Statement

- After commissioning of lean gas centrifugal compressors, Seal gas supply DP and flow to both ends of the compressor was fluctuating excessively
- Seal gas supply DP fluctuation was hitting DP low alarm
- Potential adverse impact on dry gas seal reliability and associated production loss
- Pulsations were temporarily controlled by pinching the root valve on the seal gas reference line

Installation Reference

- Qatargas is one of the world's largest LNG producing companies
- It operates four Lean LNG (LLNG) mega trains, each having a capacity of 7.8 MTA
- The mega trains were commissioned within the last 3-1/2 years
- Last train was commissioned in December 2010

Compressor Service Overview

- Lean gas compressor \Rightarrow Compresses lean gas for feed to refrigeration section at constant discharge pressure
- Single suction centrifugal compressor \Rightarrow driven by a extraction / condensing steam turbine
- Centrifugal compressor suction \Rightarrow received from discharge of two upstream expander compressors

Description of Sealing System

- DGS's in tandem arrangement with intermediate N₂ supply are installed on the compressor
- Primary seals are continuously supplied with filtered gas from the compressor discharge
- SG pressure is kept slightly higher than cavity pressure downstream of the balance drum
- Differential pressure controller controls the DP between SG cavity and SG supply pressures to maintain the required gas flow to dry gas seals

Description of Sealing System

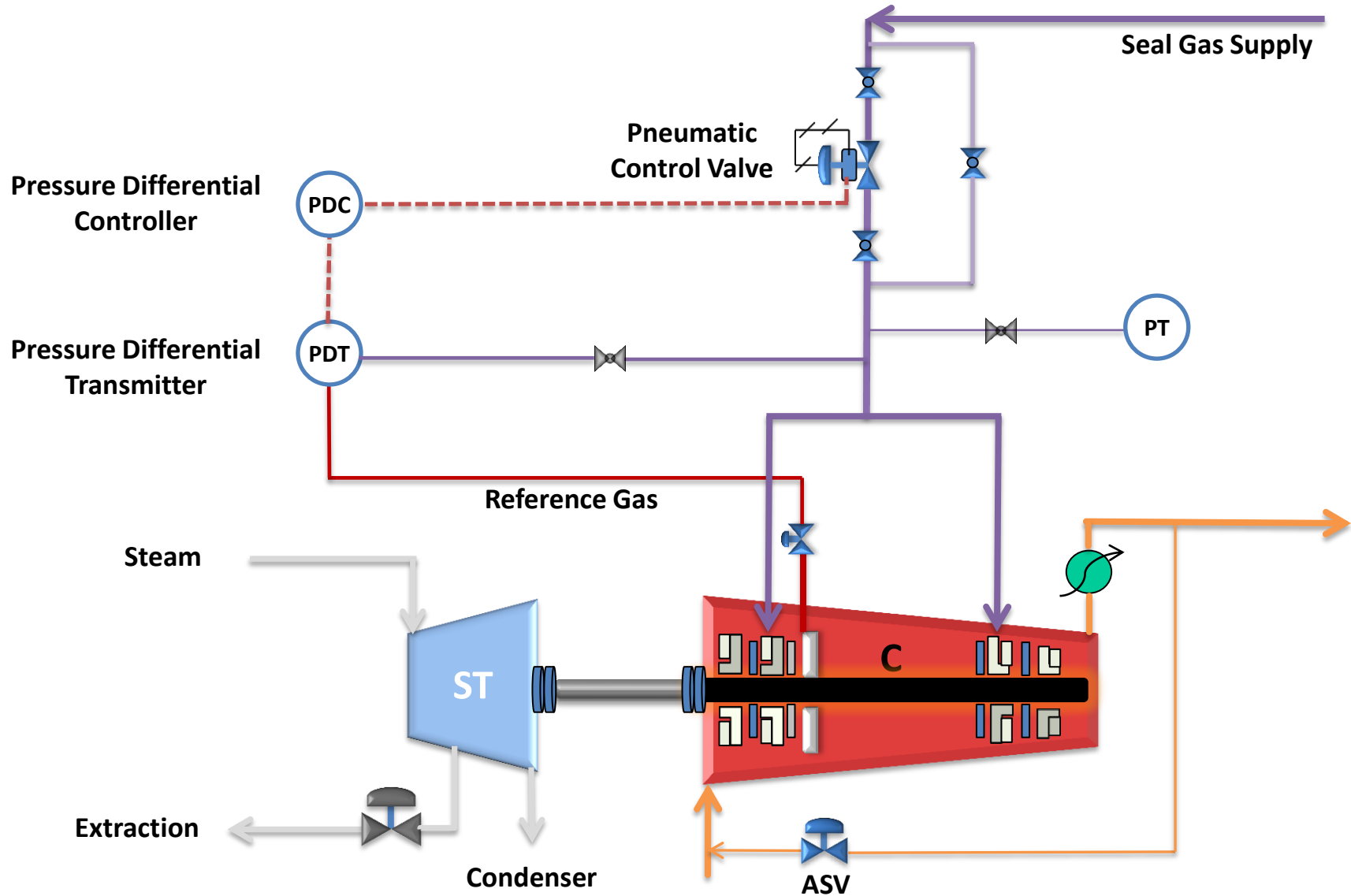

Fluctuation of Seal Gas Supply Differential Pressure of Dry Gas Seals

Problem Description

1. Seal gas supply pressure was fluctuating excessively (0.5bar – 1.2bar) due to hunting of the differential pressure control valve
2. DP controller at the seal gas supply was fluctuating leading to item #1
3. Potential adverse impact on DGS reliability
4. Pulsations were temporarily damped (0.8bar-1.2bar) by pinching the root valve on the seal gas reference line

Problem Statement

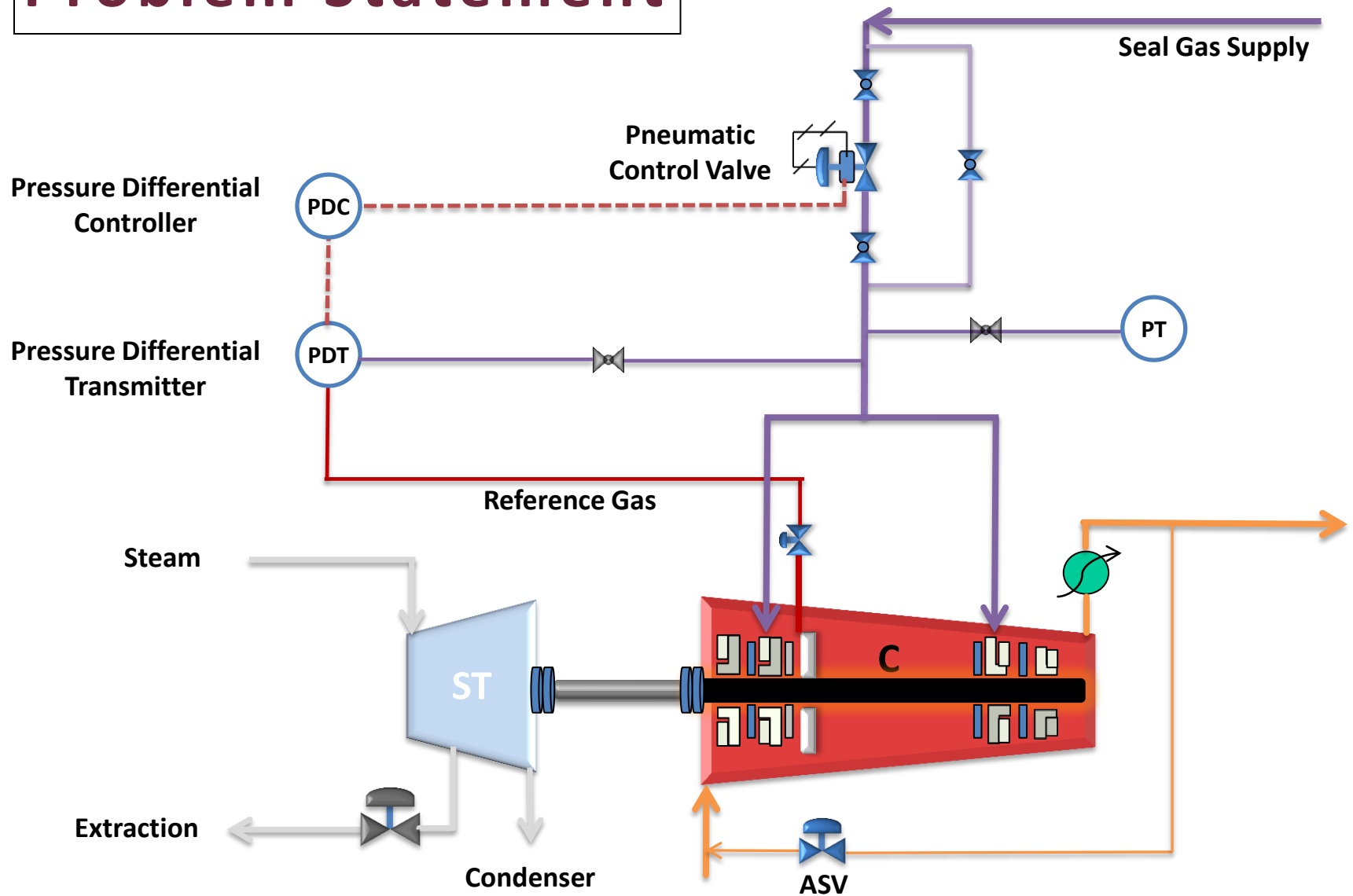

Fluctuation of Seal Gas Supply Differential Pressure of Dry Gas Seals

Troubleshooting

- DP fluctuation was persisting even when the control valve was on manual mode
- Possible causes of DP fluctuations
 - ⇒ Pressure fluctuations on seal gas reference line
 - ⇒ Pressure fluctuation on primary seal gas supply line
- Temporary arrangement was installed on the LP sensing line of the DP controller to obtain pressure trend on DCS

Troubleshooting

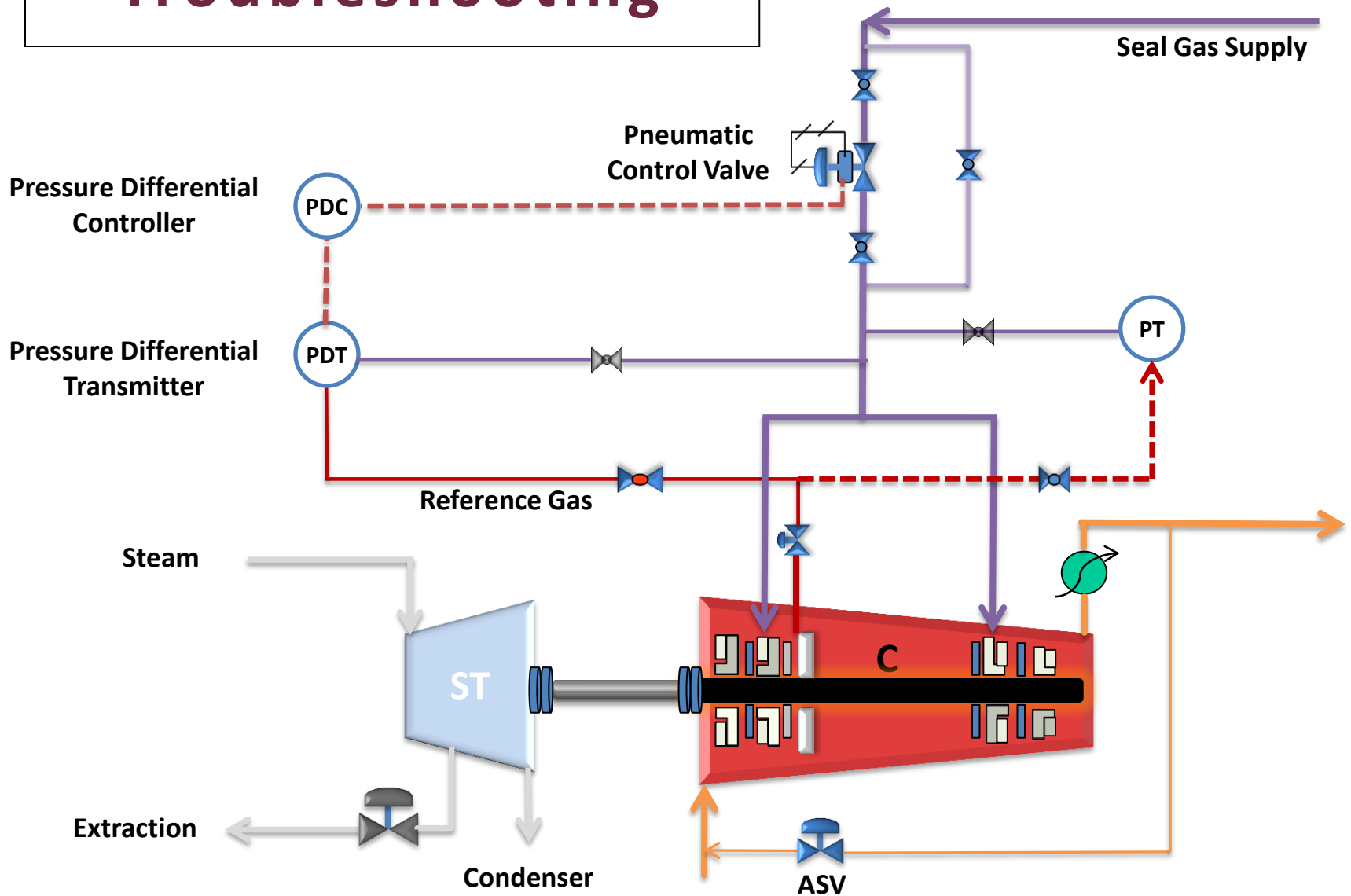

Fluctuation of Seal Gas Supply Differential Pressure of Dry Gas Seals

Troubleshooting

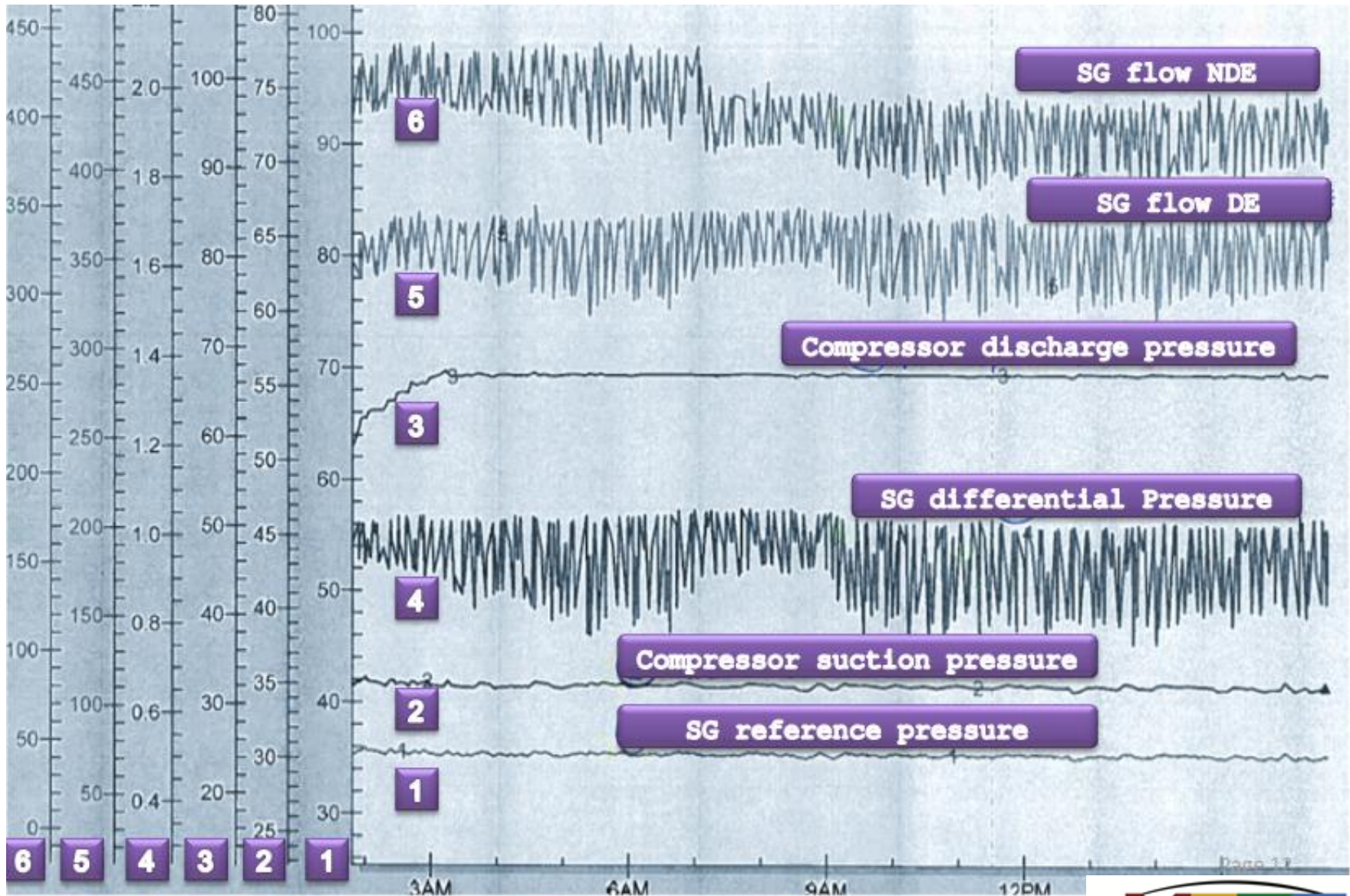

Fluctuation of Seal Gas Supply Differential Pressure of Dry Gas Seals

Cause-Effect Analysis

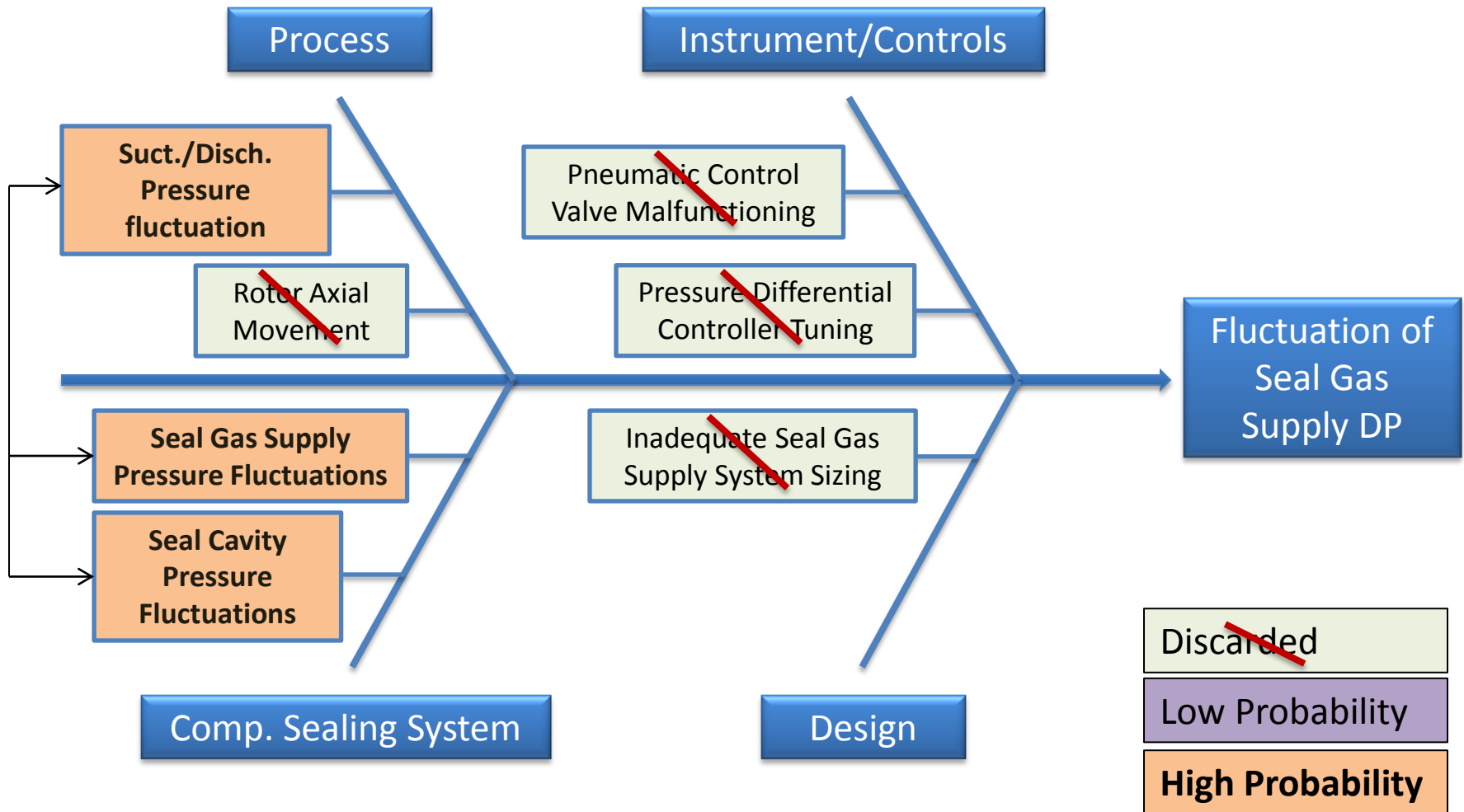

Findings

1. Seal cavity pressure was fluctuating
2. Slight fluctuation in seal gas supply pressure was also present
3. As a result of item #1 & 2 seal gas DP was fluctuating

Conclusion

1. Reference gas pressure pulsations were identified as root cause of the seal gas supply DP fluctuation
2. The DP fluctuations were attributed to process fluctuations

Remedial Actions

Per OEM's recommendation after risk review:

- Self cleaning pulsation dampeners were added on both seal gas reference and seal gas supply tubes going to PDT
- Volume bottles were added on both the impulse tubes of pneumatic controller
- Purpose of adding pulsation dampeners and volume bottles was to dampen the pressure signals

Problem Resolution

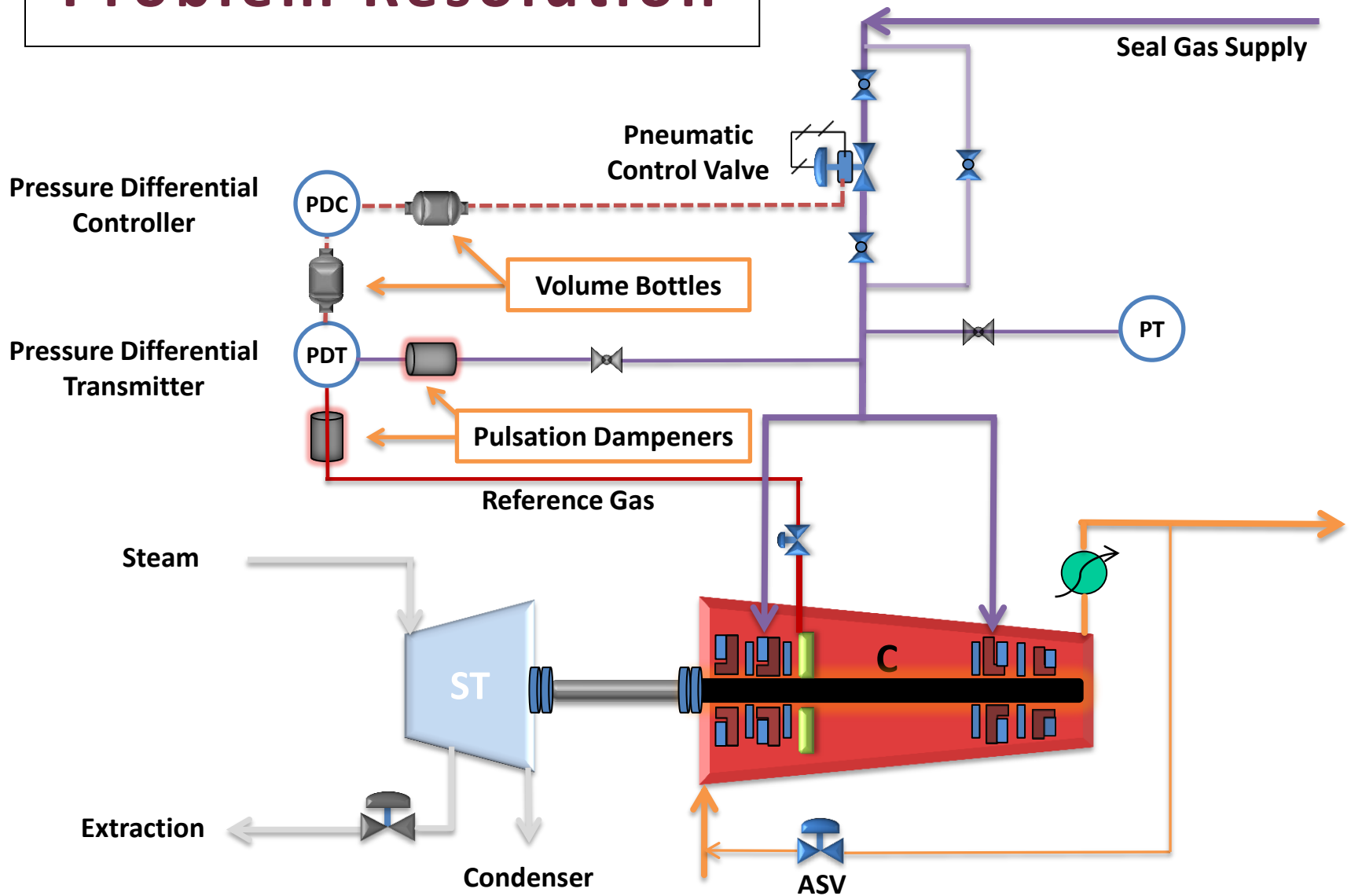

Fluctuation of Seal Gas Supply Differential Pressure of Dry Gas Seals

Pulsation Dampening Hardware

Self Cleaning
Pulsation Dampener



Volume Bottle

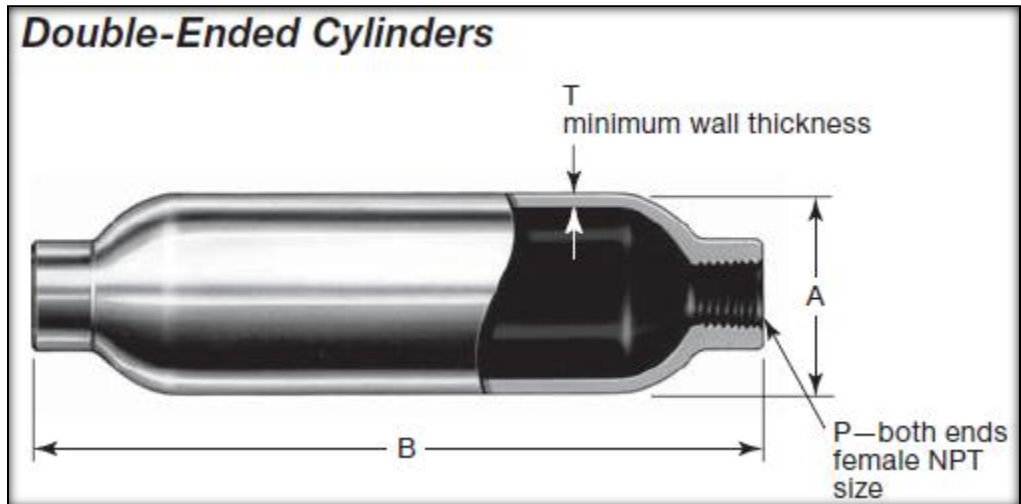

Results

Proposed change implemented on compressor for trial purpose

- *Trends were taken again to compare the change in pressure fluctuations*
- *Differential pressure control valve hunting minimized*
- *Differential pressure fluctuations reduced to acceptable level*
- *The reliability of dry gas sealing system improved*
- Modification was also done on other similar compressors because of same issue of DP fluctuation

Post Modification Trends

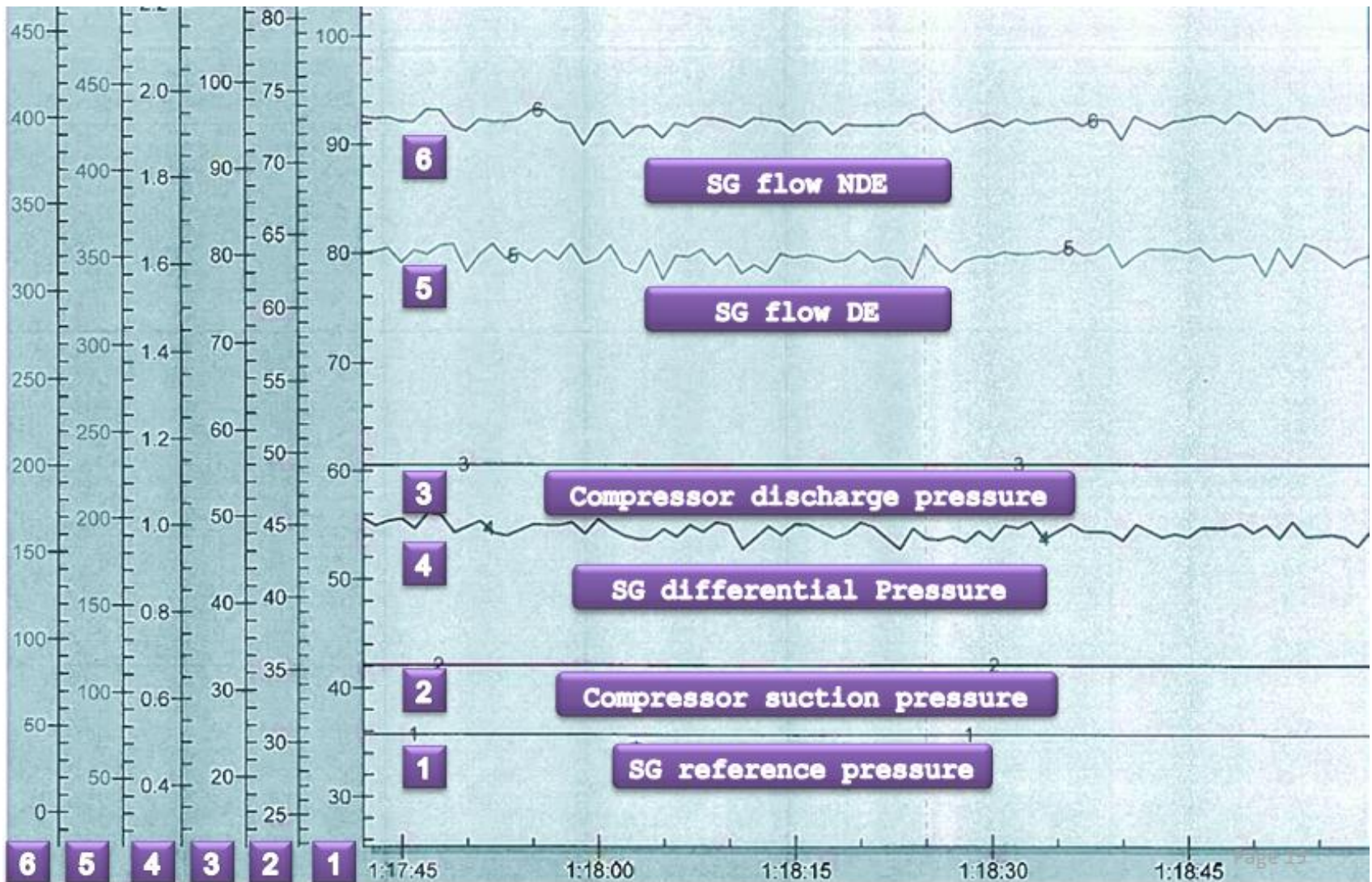

Fluctuation of Seal Gas Supply Differential Pressure of Dry Gas Seals

Pre Modification

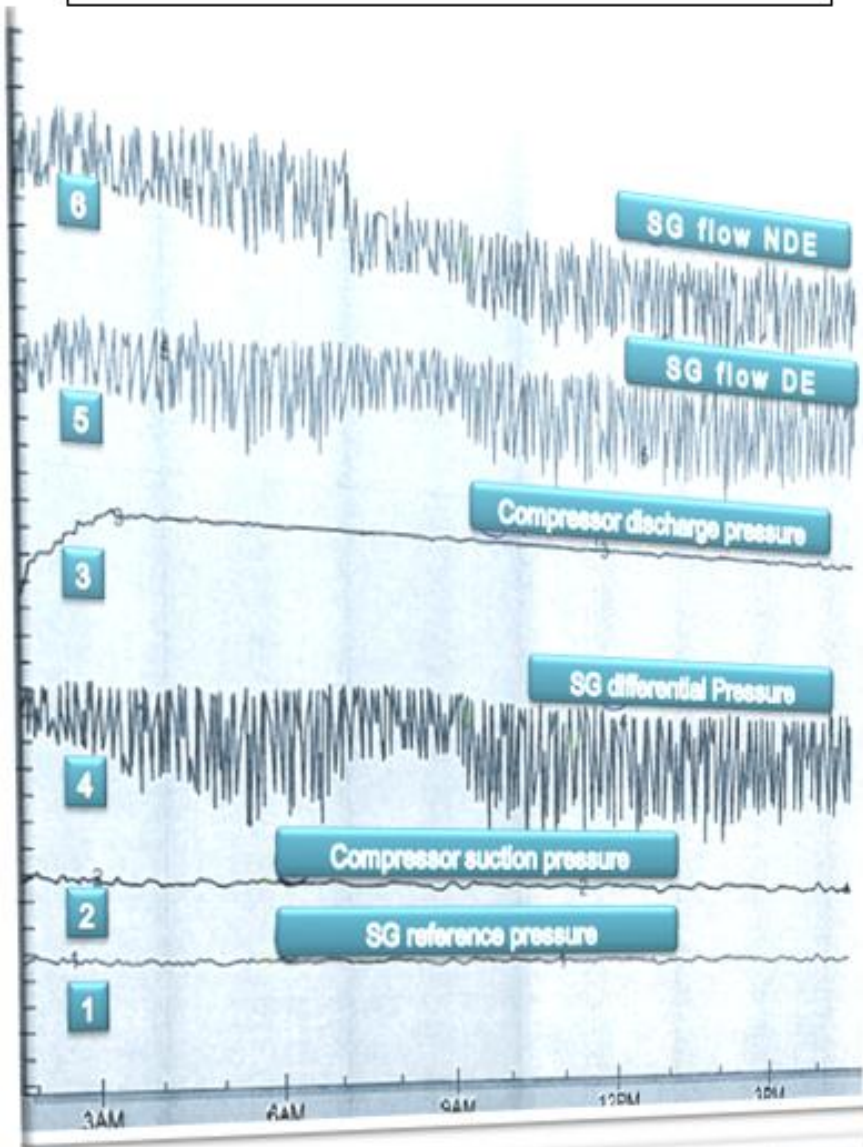

Post Modification

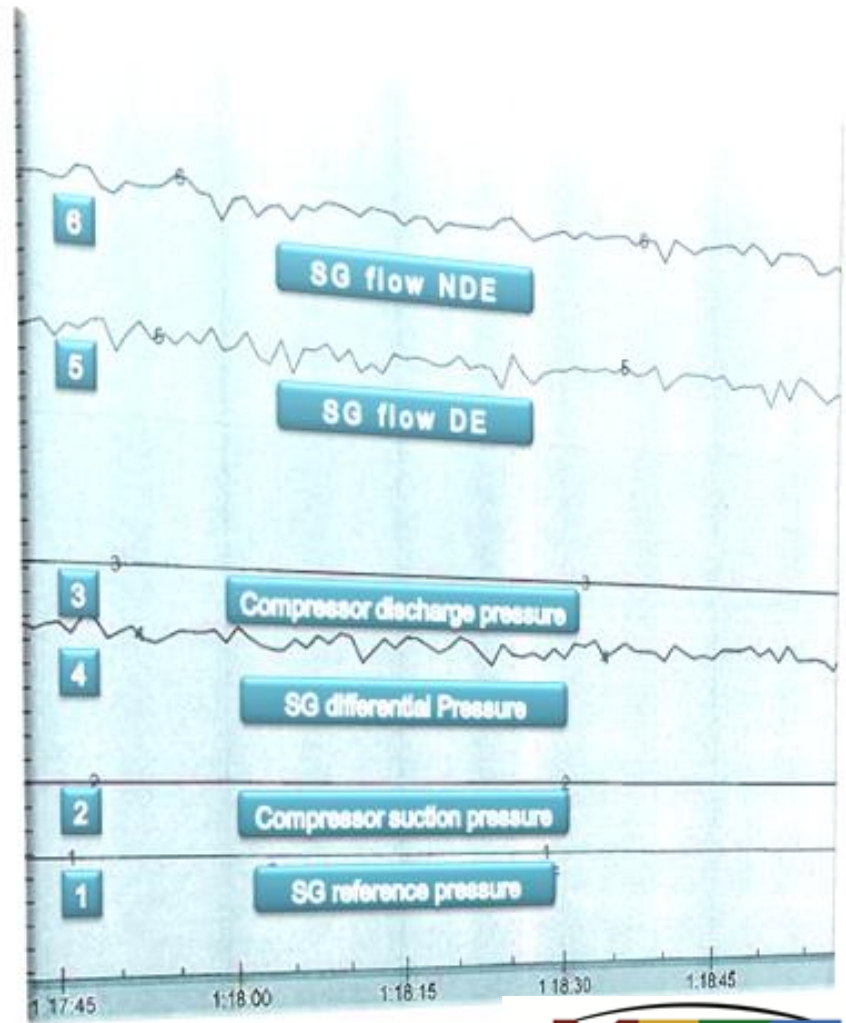

Fluctuation of Seal Gas Supply Differential Pressure of Dry Gas Seals

Q & A