



ASIA TURBOMACHINERY & PUMP SYMPOSIUM  
MARCH 2018 | SUNTEC SINGAPORE

# **Gear Box Bull Gear high vibration due to Fluid instability and analytical evaluation of New Bearing Design Case Study from ExxonMobil Singapore**



**TURBOMACHINERY  
LABORATORY**  
TEXAS A&M ENGINEERING EXPERIMENT STATION



**TEXAS A&M  
UNIVERSITY**

# Authors

---

Bhagyesh Chavda  
Lead Machinery Engineer  
ExxonMobil, Singapore

Graduate in Mechanical Engineering from India and having 10+ years of experience for Rotating Equipment in Refinery application

---

Saqib Ashraf  
ExxonMobil Research  
Engineering

Saqib has 25+ years of experience for Rotating Equipment and currently positioned as Regional Specialist (SEA)

---

John Kocur  
ExxonMobil Research  
Engineering

John has 25+ years of experience for Rotating Equipment & Rotor Stability Analysis of Turbo Machinery

---

Heinrich Baer  
Head of customer  
consulting PGSK  
MAN Diesel & Turbo SE

Mr. Baer made his university degree 1990 at the university of Muenster / Germany  
He has more than 25 years of experience in the service of process gas screw compressors

---



# Abstract

Three shaft Gear Box upgraded to meet Screw compressor model upgrade. Gear Box was installed, as a part of compressor upgrade project, with Bentley Nevada 3500 Shaft vibration protection facility and observed trip on commissioning. Detail analysis of shaft vibration plots clearly indicated sub-synchronous vibration component as source of machine trip which is attributed due to Fluid instability inside the bearing. The case study represents gear box shaft high vibration detail analysis and proposed Bearing Modification for resolution.



# Agenda

- 1 Compressor train overview
- 2 Compressor upgrade background
- 3 Observations - Gear vibration characteristics
- 4 Analysis of bearing design
- 5 Proposed counter measure
- 6 OEM's other experience
- 7 Results & Summary



# Compressor train overview

Tag # C3303

MAN Diesel & Turbo SE

Dry Screw compressor

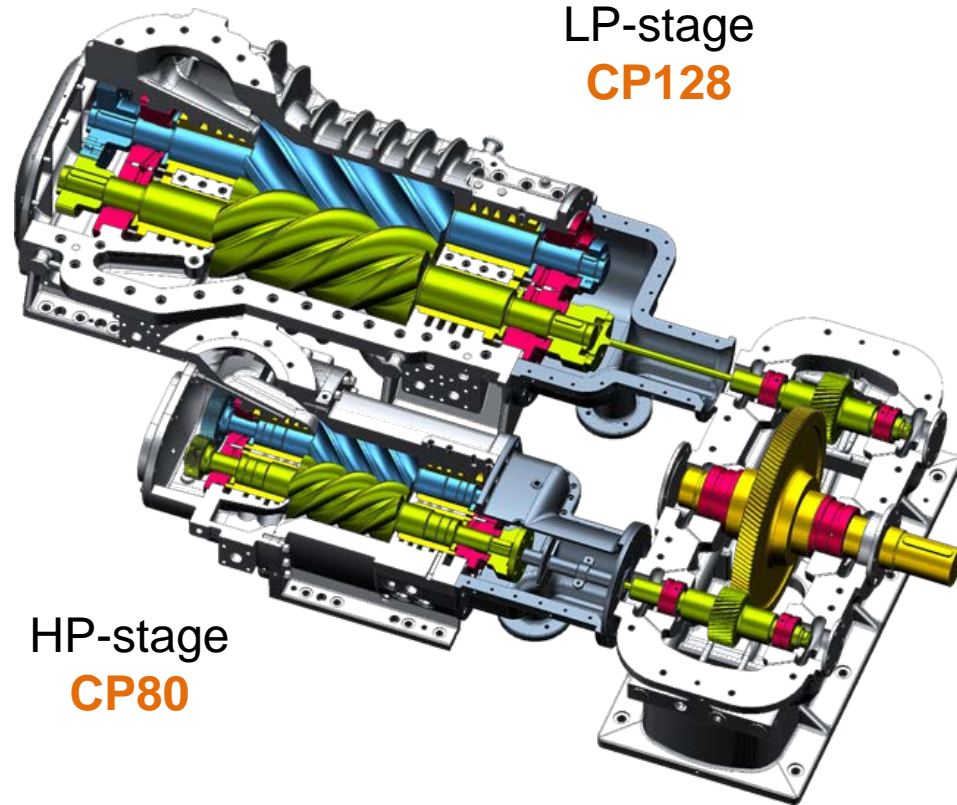

LP-stage  
CP128

HP-stage  
CP80

Gear Box  
B60



# Operating Details

Operating data :	LP-stage	HP-stage
Suction pressure :	1,01 bar	4,6 bar
Suction temperature :	37,8 °C	37,8 °C
Discharge pressure :	4,8 bar	19,96 bar
Discharge temperature :	120	126 °C
Male rotor speed :	11.519 rpm	19.312 rpm
Volume flow :	1917 m <sup>3</sup> /h	
Power consumption :	366 kW	



# Gear Box Details

- Make: MAN Diesel & Turbo SE
- Model: B60
- Type: Speed Inserter, Single Helical, Two Stage
- Low Speed Input : 2971 RPM
- High Speed Out put-1: 11643
- High Speed Out put-2: 11643
- Rated Power: 410 KW
- Gear Ratio: 3.919
- Pitch line velocity: 73.8 m/sec
- Bearing Type : Bush Type Journal bearing
- Bull Gear Vibration Alarm : 90 microns
- Bull Gear vibration Trip : 110 microns

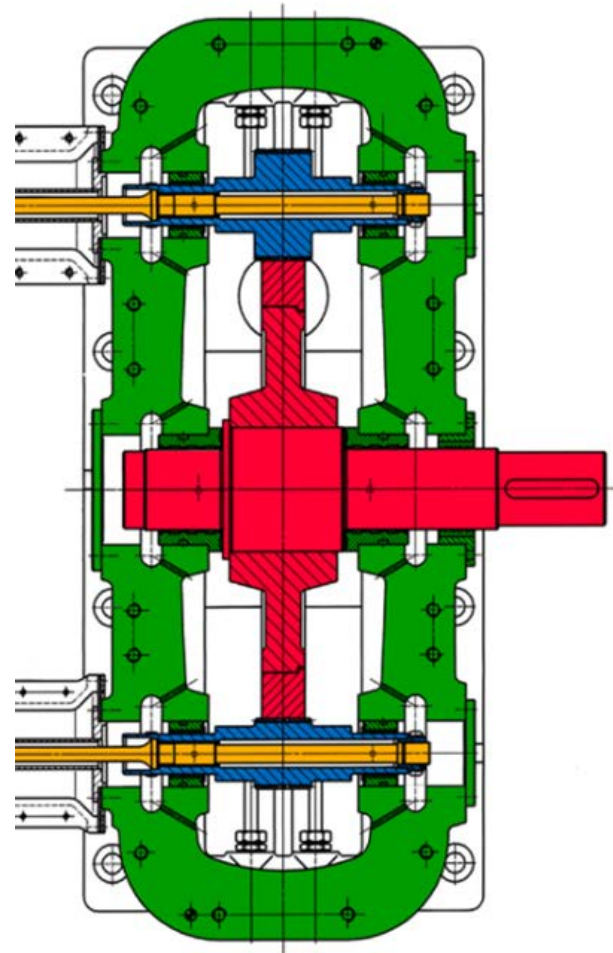

# Compressor train upgrade background

- Following upgrades were carried out on Compressor train during recent turnaround
  - HP-stage compressor upgraded to CP80 model as SKUES10 model is no more supported by MAN
  - Gear box upgrade due to change in compressor speed which is required for upgraded HP stage model CP80
  - Stage-1 & 2 Discharge muffler upgrade from Normal screen type to Lamda type design to mitigate fouling concerns
  - Duplex suction strainer installation for LP compressor to eliminate downtime required for strainer cleaning
  - BN3500 Upgrade and conversion to Proximity probe
- Compressor tested post above mentioned upgrades and observed with Gear box Bull Gear (Low speed) shaft high vibration up to  $\sim 92\mu\text{m}$  (expected  $< 30\mu\text{m}$ )

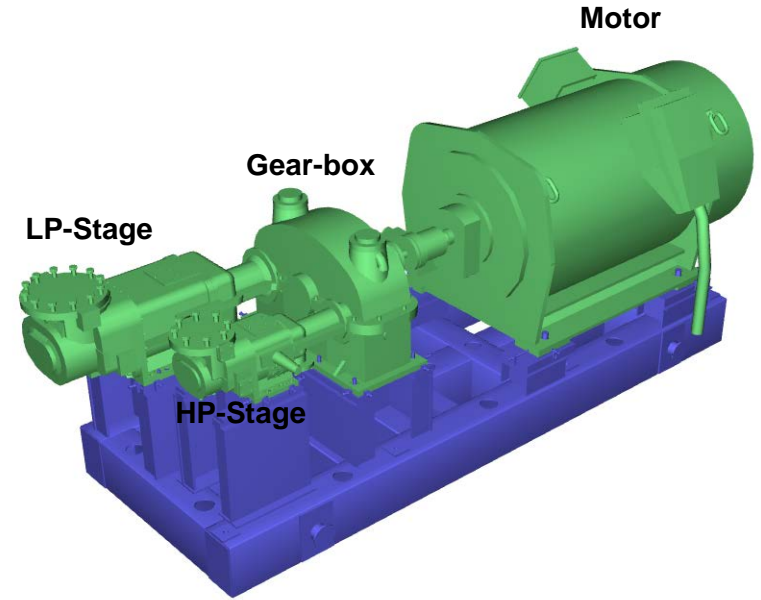



# Observations

- During First Trial Run, Bull Gear DE-X Probe and NDE Y-Probe observed with elevated vibration levels up to 100 microns
- Pinion vibrations were within limits and low as ~25 microns
- All the bearing temperatures within compressor train observed within Normal operating range

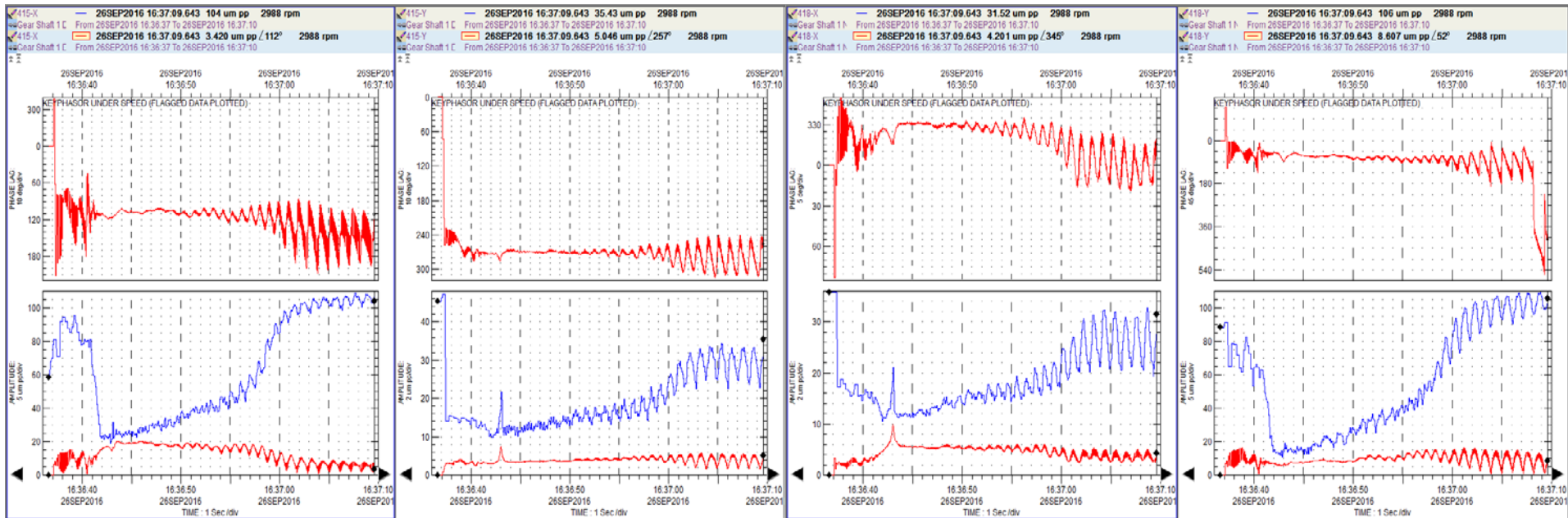

Trend Plots – Bull Gear DE and NDE



# Observations

- Full Spectrum clearly shows Sub-synchronous vibration component as dominant fault frequency

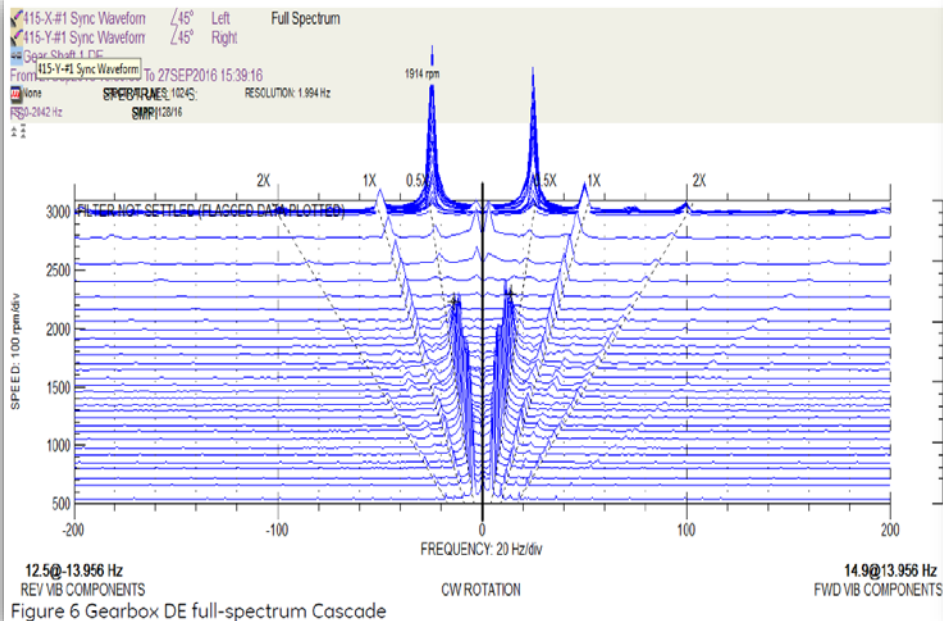

Figure 6 Gearbox DE full-spectrum Cascade

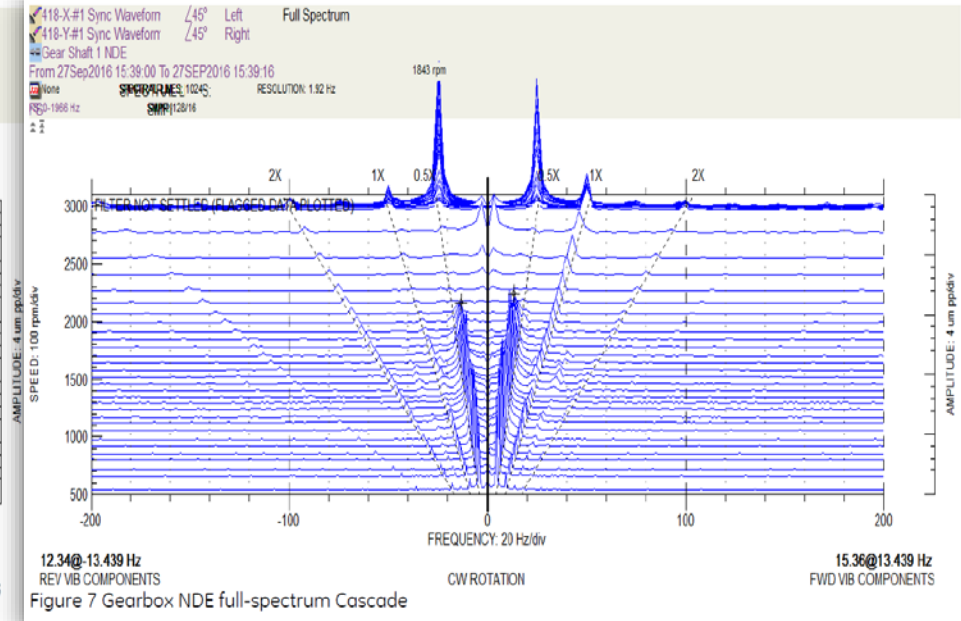

Figure 7 Gearbox NDE full-spectrum Cascade



FULL SPECTRUM Plots – DE and NDE

# Observations

## POLAR Plots

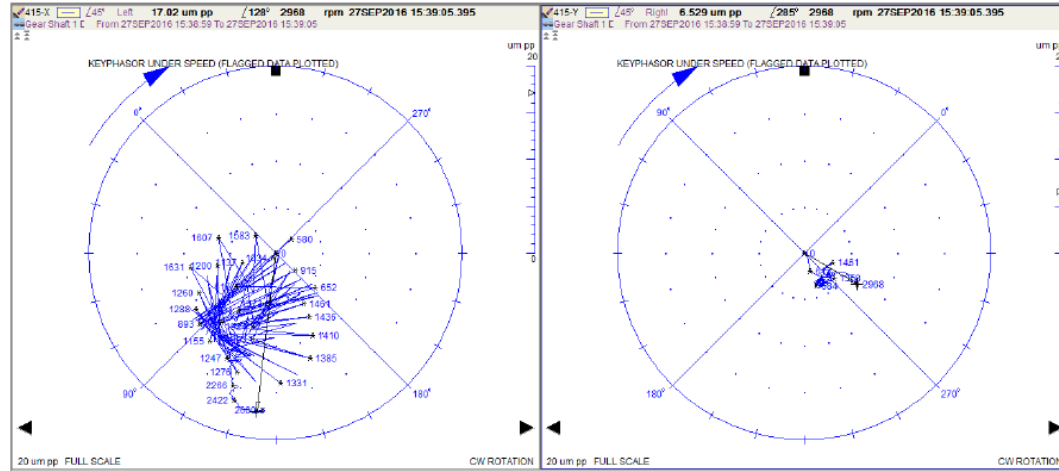

Figure 4 Gearbox DE Polar plots.

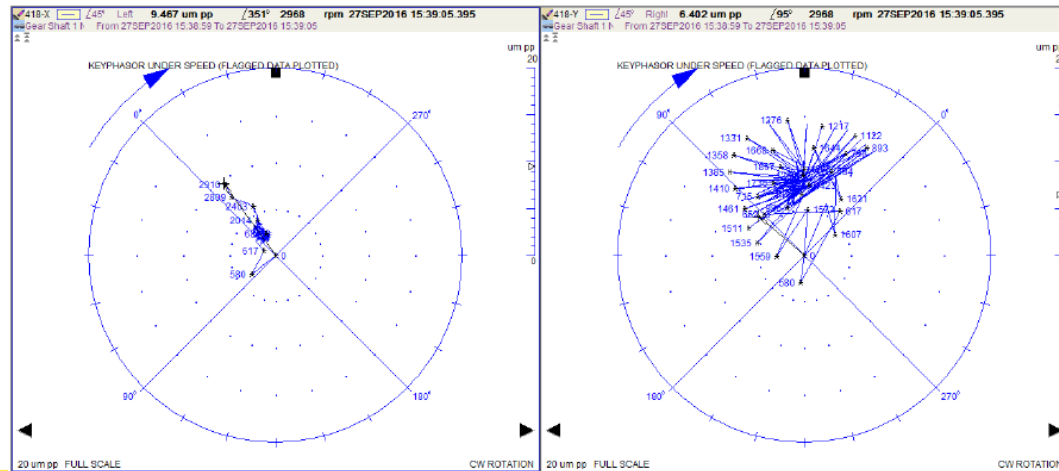

Figure 5 Gearbox NDE Polar plots.



# B60 original bearing design

Max admissible power:	760KW at 1500rpm (AGMA rating)
Pinon to pinon center distance:	600mm
Max oil heat:	18KW at 3600rpm
Weight:	approx. 700kg
No. of teeth:	145 / 37 / 37
Bearing diameter:	85mm (wheel); 55mm (pinions)
Circumferential Velocity:	13,23 (wheel) 33,53m/s (pinions)
Pitch line velocity:	73,79m/s
Weight forces:	981N (wheel); 107N pinion 1; 98,1N (pinion 2)
Bearing forces:	next page



# B60 original bearing design

## Bearing calculation table

	Surface [cm <sup>2</sup> ]	Load [N]	Specific load [N/mm <sup>2</sup> ]	
Gear wheel DE	45,9	606	0,048	⚡
Gear wheel NDE	45,9	218	0,132	⚡
LP-Pinion DE	24,75	1503	0,707	✓
LP-Pinion NDE	24,75	1750	0,607	✓
HP-Pinion DE	24,75	606	0,463	✓
HP-Pinion NDE	24,75	718	0,388	✓
Gear wheel axial	65,1	2081	0,277	✓

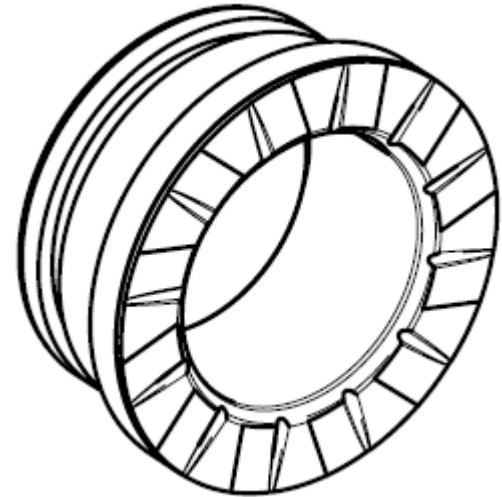

# B60 original bearing design

Observation:

Non synchronous shaft vibrations at bull gear shaft

The high shaft vibrations ( $> 90\mu\text{m}$ ) measured were dominated by a non synchronous vibration component with a frequency of about 50% of gear wheel speed. Except this all other shaft vibrations of the complete machine train were well below the acceptance limits.

Typical causes for high shaft vibrations like unbalance or bad run out could be excluded in this case, as they would appear as synchronous vibration readings.

The characteristic of the 0,5x vibration is typical for bearing instabilities like the well known oil whirl / oil whip effect. Cylindrical bearings in general cause the rotor to “whirl” in its bearings with frequency of almost half ( $\approx 0.48$ ) of its rotating speed.



# Discussion On High Vibration

- Bentley Nevada Plots clearly showed high vibration spectrum with 0.5X Component as dominant frequency. Also varying Phase Angel also suggested Bearing/ shaft instability or Rotor Rub while running on Full Load condition of the machine
- Primary Analysis from MAN TURBO suggested Fluid instability of the bearings. Calculated load on gear wheel bearings observed to be quite low on both bearings ( $0.047 \text{ N/mm}^2$  &  $0.132 \text{ N/mm}^2$ ) which is ultimately unloading the gear wheel.
- Downward Mesh in Stage-1 Pinion and Upward mesh in Stage-2 pinion are Actually unloading the Bull Gear Shaft with the design loading condition of the gear box

## Discussion with OEM

- During 2009 purchase, Gear Box was shop tested with Partial load condition (137 KW load compared to 410 KW) but no abnormality was observed
- As per OEM, this is the First B60 Model gear box with Proximity probe interface for vibration protection and OEM doesn't have any experience data available to share

**Note :** There is no significant change in load condition due to upgrade of Stage-2 machine with newer model but OEM has the very first experience with Proximity probe on the B60 Model gear boxes which was not recognized by OEM is past

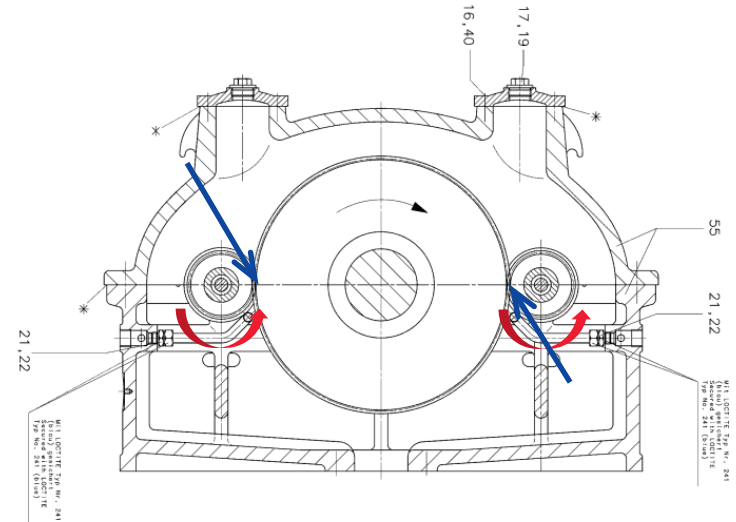

# B60 new 4-lobe bearing design

Basic data remained the same , only gear wheel bearings were changed

Radius of eccentricity : 43mm

Preload factor: 0,892

	Surface [cm <sup>2</sup> ]	Load [N]	Specific load [N/mm <sup>2</sup> ]	
Gear wheel DE	45,9	606	0,15	✓
Gear wheel NDE	45,9	218	0,23	✓
LP-Pinion DE	24,75	1503	0,707	✓
LP-Pinion NDE	24,75	1750	0,607	✓
HP-Pinion DE	24,75	606	0,463	✓
HP-Pinion NDE	24,75	718	0,388	✓
Gear wheel axial	65,1	2081	0,277	✓





# Proposed Solution

- OEM Proposed to change the Bearing design from Normal Bush type bearing to 4-loabe profile bearing design

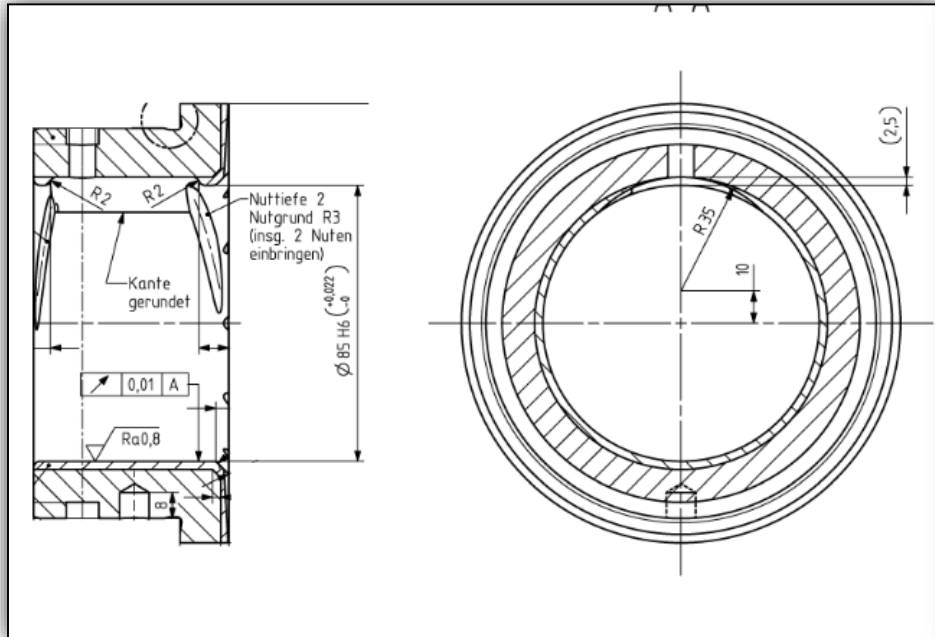

OLD DESIGN

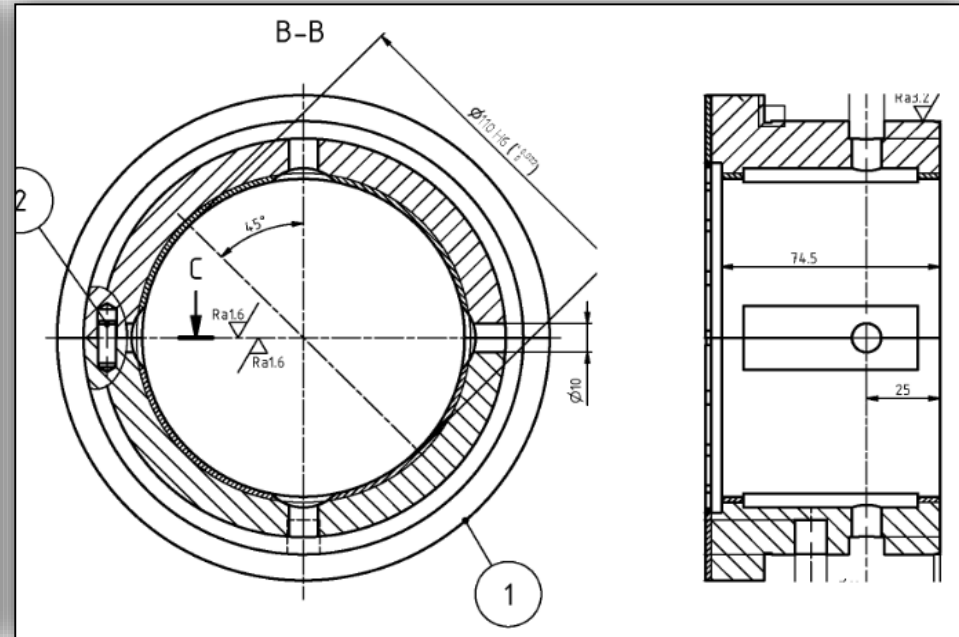

NEW PROPOSED DESIGN

## Experience made with another gear same design but larger type (B85 instead of B60)

- In 2011 MAN Diesel & Turbo tested 3 identical B85-type gears on their test bench
- The gears passed the equipment test successfully (on the same test bench on which the C3303 gear was tested)
- One unit made an additional string test afterwards (electric motor, gear and both compressor stages mounted on their own base frame)
- High vibration amplitudes occurred at approx. 0,5 times running frequency of the gear wheel
- Results and measures are shown on the following slides



# Test run (string test) 2011 (B85-type gear)

## original bearing design (cylindrical)

POINT: VE 7514 X /45° Right  
MACHINE: Gearbox BG INDE  
From 21MAR2011 11:39:40.4 To 21MAR2011 12:59:21.3 Startup 11:39:40.4  
WINDOW: Hanning SPECTRAL LINES: 400 RESOLUTION: 2.5 Hertz

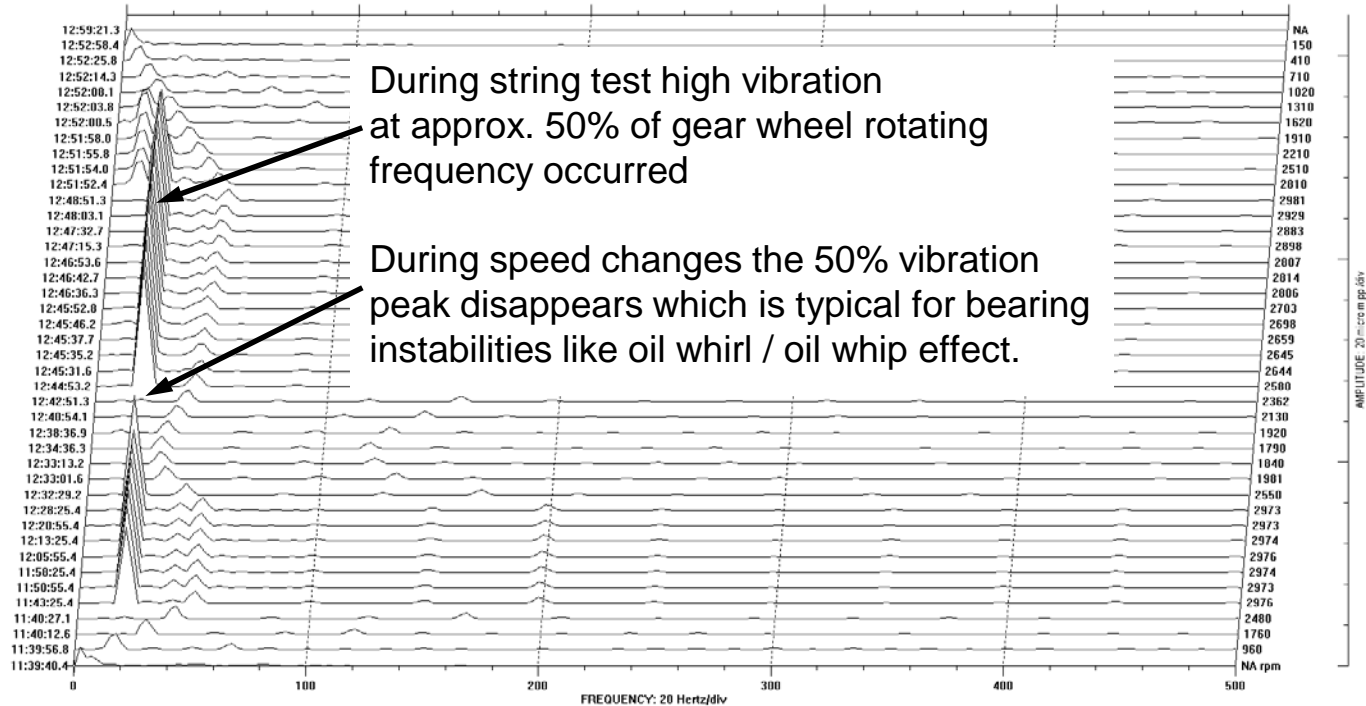

# Test run (string test) 2011 (B85-type gear)

original bearing design (cylindrical)

POINT: VE 7514 X /45° Left DIR AMPL: 64.2 micro m pp  
MACHINE: Gearbox BG NDE MACHINE SPEED: 2580 rpm  
21 MAR 2011 12:44:53.2 Startup  
WINDOW: Hanning SPECTRAL LINES: 400 RESOLUTION: 2.5 Hertz

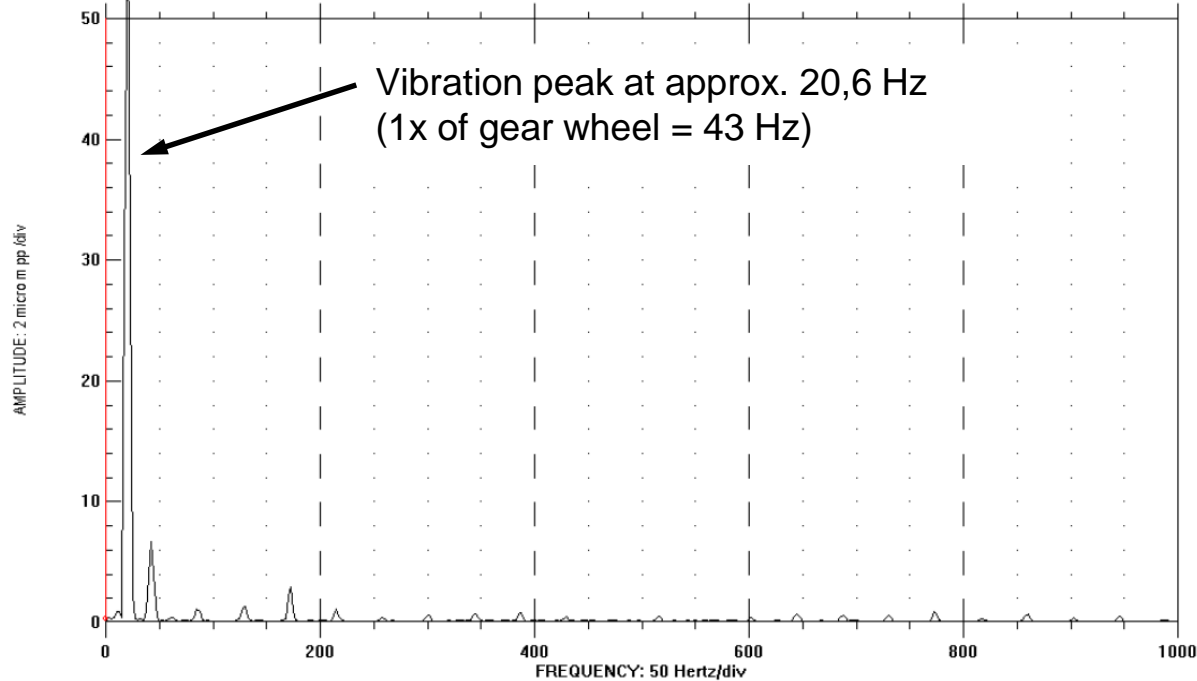

# Test run (string test) 2011 (B85-type gear)

## new bearing design (4-lobes)

POINT: VE 7514 X /45° Right  
MACHINE: Gearbox BG NDE  
From 26MAY2011 14:01:51.7 To 26MAY2011 14:34:20.1 Startup 14:01:51.7  
WINDOW: Hanning SPECTRAL LINES: 400 RESOLUTION: 1.25 Hertz

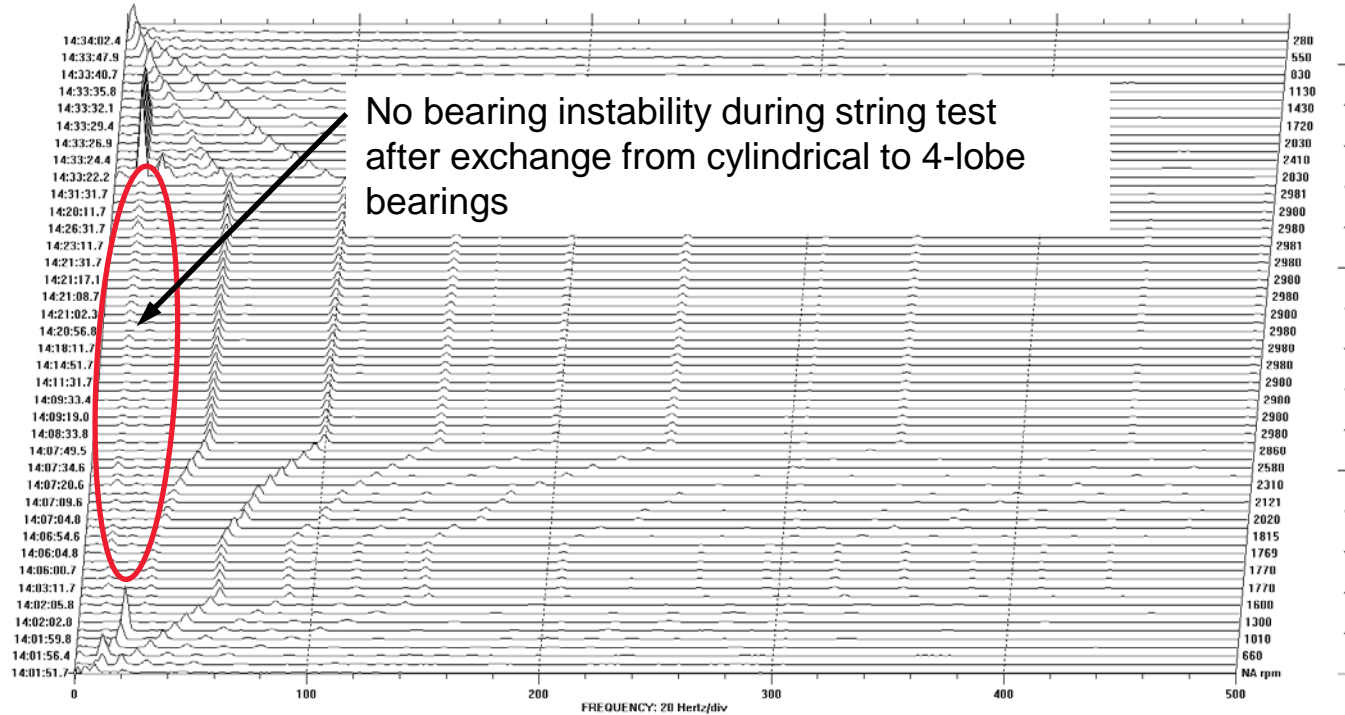

B85 gear was modified in 2 steps

Step 1:  
Cylindrical bearings with reduced length were installed  
- not successful

Step 2:  
Change to 4-lobe bearings  
- successful

# Results and Summary

- Bearing instability occurred during string test but not during equipment test
  - Equipment test → Gear box only (water brake test bench)
  - String test → Entire machine train (motor, gear, both compressor stages)
- Installation of cylindrical bearings with reduced length did not solve the problem
- Change from cylindrical bearings to preloaded 4-lobe bearings solved the problem
- The compressor units (3 identical units were sold to the client) are in service since April 2012
- After 2011 about 70% of our B-type gears were equipped with either 4-lobe bearings or lemon shape bearings



# BACK-UP



# Observations

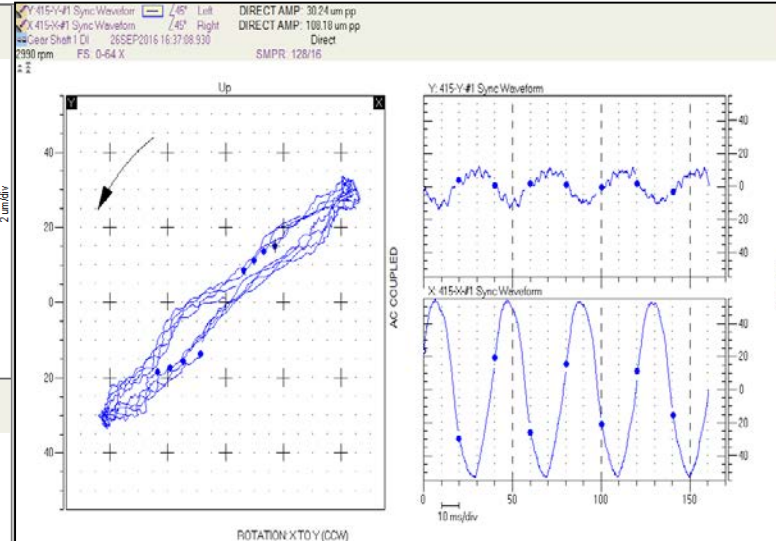
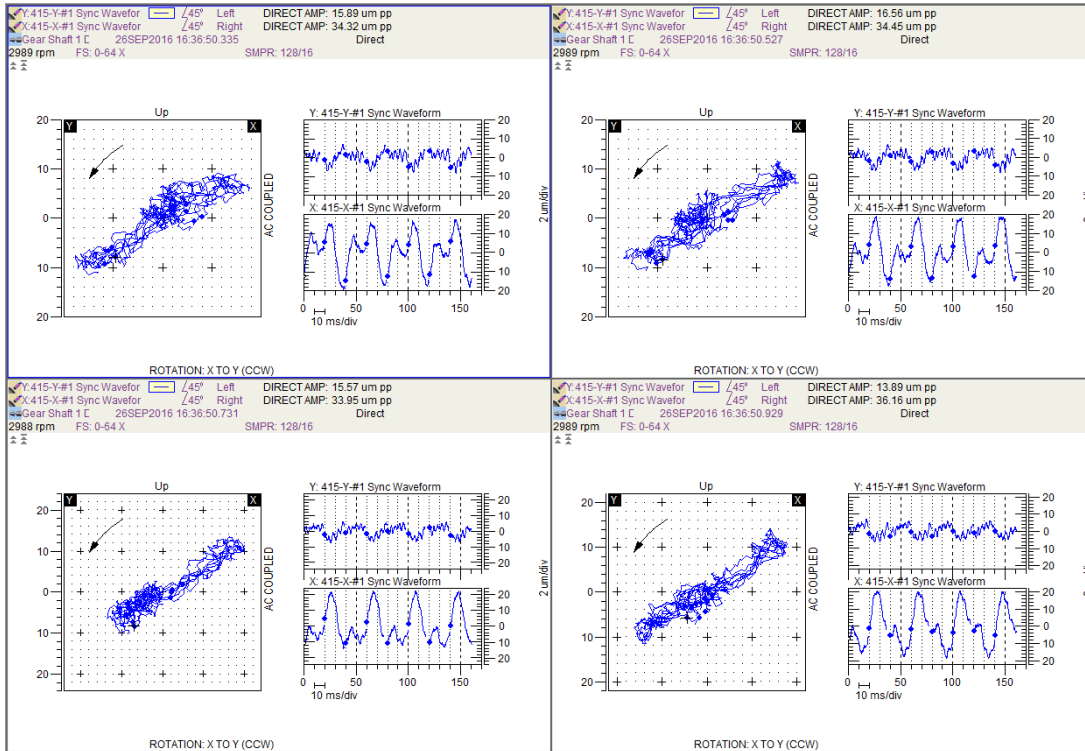

ORBIT Plots – DE Bearing



# Observations

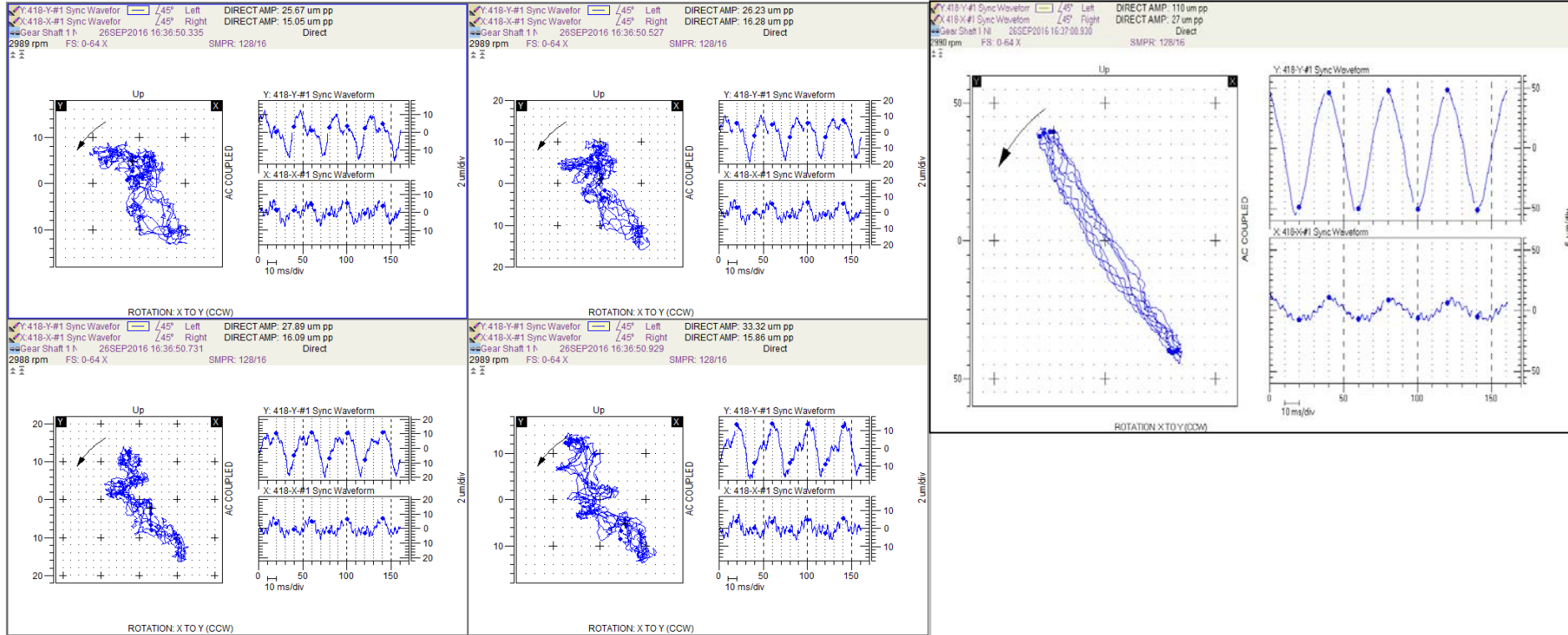

ORBIT Plots – NDE Bearing



# Observations

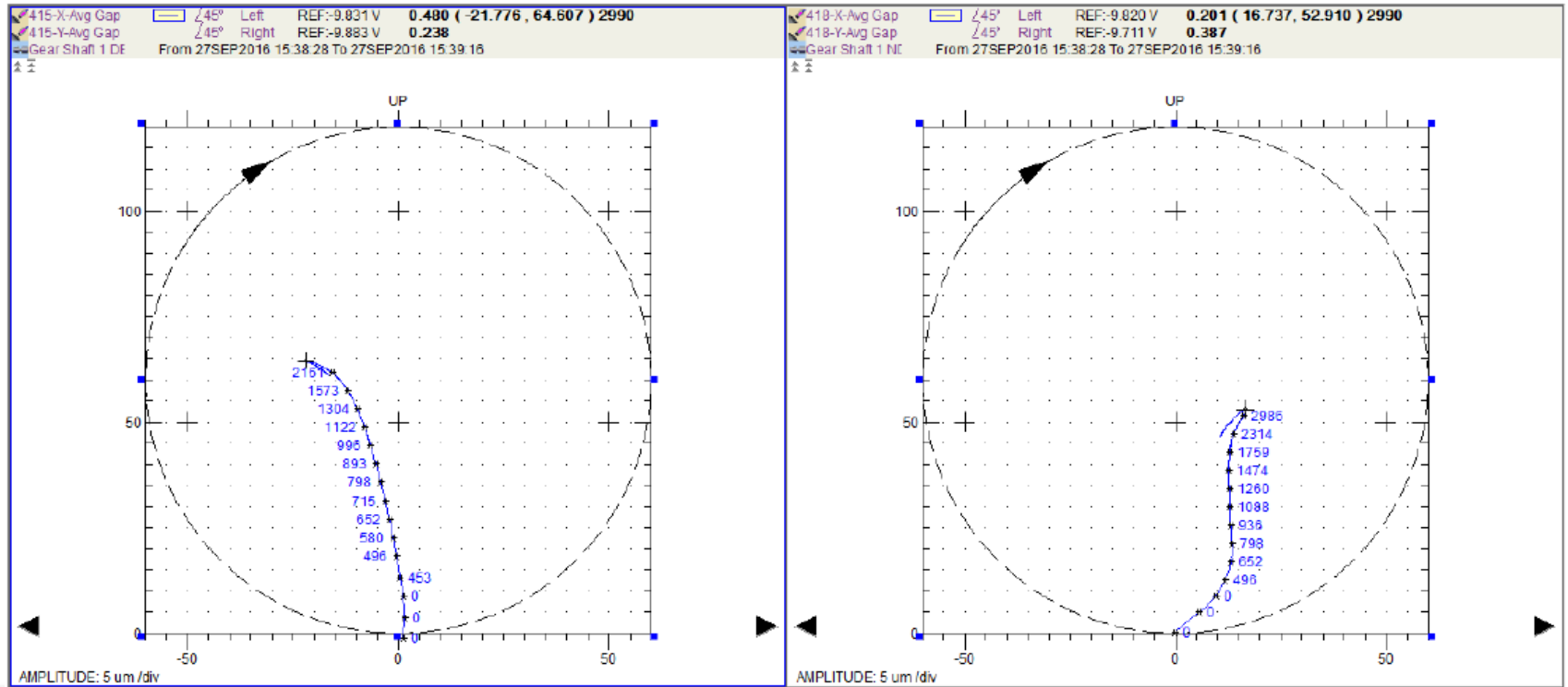

Figure 8 Gearbox DE/NDE Shaft Centerline (SU).

