

# HOW TO AVOID BUILDING PROBLEMS INTO PUMPING SYSTEMS

by

**William E. (Ed) Nelson**

Consultant

Dickinson, Texas

and

**John W. Dufour**

Chief Engineer, Mechanical Services

Amoco Oil Company

Chicago, Illinois



*William E. (Ed) Nelson is the author of more than 40 technical papers, a speaker at many turbomachinery seminars, and a contributor to several handbooks on machinery maintenance and operation. He is the coauthor of Centrifugal Pump Sourcebook. He has received six patents on refinery and gas turbine maintenance techniques.*

*Mr Nelson was a founding member, with 20 years service, on the Turbomachinery Symposium Advisory Committee. He was*

*also a founding member of the International Pump Users Symposium Advisory Committee. Other affiliations include the Vibration Institute, IMI, and ASME.*

*Mr. Nelson retired from Amoco Oil Company, Texas City, Texas, after more than 36 years of service. Responsibilities in his last position included refinery instrument and electrical repair, weld shop functions, operation of mobile equipment such as large cranes, etc., and rotating machinery maintenance and repair, along with craft training.*

*He received a B.S. degree (Mechanical Engineering) from Texas A&M University and is a registered Professional Engineer in the State of Texas. In 1992, he was honored as a "Distinguished Engineering Alumni" by the College of Engineering and as a member of the "Academy of Distinguished Former Students" by the Mechanical Engineering Department at Texas A&M. He recently had a test cell named in his honor in the new Turbomachinery Laboratory research facility on the Texas A&M University campus.*



*John W. Dufour has over 20 years experience working with mechanical equipment. In his current position as the Chief Engineer, Mechanical Equipment Services, for Amoco Oil Company, his responsibilities include the initial specification, selection, field installation, and consultation for all rotating equipment, FCU internals, fired heaters, and flare systems throughout the company's refinery, pipeline, and marketing operations.*

*A 1974 graduate of Michigan Technological*

*University, Mr. Dufour holds B.S. degrees in Metallurgical Engineering and Engineering Administration. In addition to being a veteran of the United States Navy Nuclear Powered Submarine program, he is vice chairman of the API subcommittee on Mechanical Equipment, a member of ASM, ASTLE, and currently sits on the Industrial Advisory Council for the Mechanical Engineering Department of Michigan Technological University. Mr. Dufour is the*

*author of numerous technical publications, articles, and training programs on mechanical equipment and is a coauthor of the book Centrifugal Pump Sourcebook.*

## ABSTRACT

A poorly performing pump frequently exhibits both hydraulic and mechanical problems. Excessive noise, vibration, degradation of discharge pressure, repeated bearing failures, and sometimes impeller breakage lead to high maintenance costs and reduced service availability. A problem pump requires looking at even the smallest of details to effect a long term solution. A discussion of problems that have been encountered in pumps is presented, along with some case histories.

## BEGINNING THE PUMPING SYSTEM EVALUATION

Methodical analysis will help to identify the sources of a pumping system's problems. The first reaction of many engineers is to decide which piece of electronic gadgetry to use in gathering data. A more productive first step is a simple review of the pump and its installed system. Review the maintenance records. Go to the pump and have the operator explain what he saw during the latest problem period. If possible, run the pump and demonstrate the problem. While there, look around at the piping, the foundation and other physical aspects of the pump installation. Because few people really look at the entire system, many installation flaws continue to cause problems for years before they are finally corrected.

A typical pumping system can be divided into nine areas for evaluation purposes:

- the foundation—poor foundations, grouting and flexible base-plate designs can cause many problems.
- the driver—excitations from the vibrations of the driver (motor, steam turbine, gearing) can be transmitted to other components.
- mechanical power transmission—excitations from the coupling area, especially due to misalignment of the driver or eccentrically bored coupling hubs. Incorrect positioning of driver and pump such that distance between shaft ends (DBSE) exceeds the axial flexing limits of the coupling.
- the driven pump—design of the pump can greatly influence the hydraulic interaction between the impeller and the casing and thus the problems encountered. Operation of pumps in parallel can create major hydraulic troubles. Hot service pumps thermal growth misconceptions can cause serious problems.

- operating conditions—the pump can be operated at conditions for which it was not designed. It should be remembered that the pump tries to conform to the system hydraulic demands, not the other way around.

- the suction piping and valves—unfavorable incoming flow conditions like cavitation, intake vortex, or suction recirculation due to poor design and layout of suction piping and valves can cause flow disturbances.

- the discharge piping and valves—unfavorable dynamic behavior of piping because of loads from dynamic, static or thermal causes including resonance excitation.

- the instrumentation for control of pump flow—control system/pump interaction during startups or other periods of low flow can produce pressure pulsations. High pressure pulsations can occur due to hydraulic instability of the entire pumping system, and

- failure to maintain the alignment—once it is established, dowels into the baseplate must hold the pump alignment.

Several of these areas do not get detailed discussion in handbooks and technical journals. The fourth topic, pump design, has received attention in only the last decade and the subject is not fully understood. The last five areas get only limited coverage or a passing comment. Few of the areas are discussed as they interrelated in a pumping system. It is impossible to cover all of the above areas in detail, but some that are the source of continuing problems will be discussed.

## DRIVER PROBLEMS

Probably the most important change in drivers in the last few years has been the development of solid-state variable-frequency inverters capable of powering medium-voltage motors. The horsepower limit of 480-volt variable speed drive (VSD) motors has been steadily rising in the last few years. As a result, variable speed drivers are becoming more common for pumps. There several different VSD motor designs available, with only limited understanding of the basic concepts employed among engineering personnel. As a result, frequent misapplications arise. These applications must be examined carefully during application to prevent problems.

### *Variable Speed Driver—A Case History*

On an installation of four 1000 hp vertical pumps, electronic excitation of a torsional critical was a problem. Three pumps were started/stopped as the sump level changed. One pump was driven by a VSD. The input to the VSD controller was the liquid level of the sump. The VSD output then controlled the speed of the one pump. As the speed of the VSD controlled pump increased, a torsional critical was excited that caused severe vibration. Initial thoughts were to replace the coupling with a torsionally resilient coupling. However, this was impractical because the pump assembly was supported by the motor thrust bearing through a rigid coupling. A detailed engineering review and a significant amount of field testing of the VSD control system discovered that the source of the torsional excitation was coming from the controller, not the pump. As the pump speed increased, and approached what normally would have been a well damped torsional critical, the controller sensed, in its feedback network, a slight decrease in speed. It then sent a signal to the motor to speed up. This cycle continued and the magnitude of the responses increased in amplitude until the vibration became unacceptable and the pump was shut down. The solution was to simply add an electronic filter in the feedback network, effectively desensitizing it, so that it would not respond to the torsional resonance.

### *Extraneous Motor Trips—A Case History*

During startup, an electric motor driver repeatedly tripped on high current and/or thermal overload. Investigation revealed that the centrifugal pump that it drove, normally pumped propane with a specific gravity of 0.53, in the revamped process utilized on the unit. The new electric motor for the pump was sized for that operating condition. However, operating procedures called for starting the unit up on kerosene with a specific gravity of 0.8. This resulted in a brake horsepower requirement almost 50 percent greater than that required to pump propane. The increased liquid gravity caused the overloading and tripping of the motor. This could have been avoided if the application engineer had been aware of the special startup conditions, or if he had based the sizing of the motor on water. Normally, almost all new installations are based on water to allow for testing at the pump manufacturer's facilities before shipping. However, in some cases, a special test motor must be used. This situation happens frequently on large vertical pumps in hydrocarbon service. As existing facilities are constantly altered to increase throughput, frequent mismatches of motor drivers and pumps, new and used, will occur.

## PUMP DESIGN—HYDRAULIC PROBLEMS

Many problems of a hydraulic nature develop in a system and are difficult to isolate and provide corrections. Liquid flow in the impeller internal channels and the casing is a very complex phenomenon, especially at off-design conditions. Interaction between the impeller and the casing causes eddy current type flows. The internal flow is unstable and unsteady, with violent changes sometimes occurring from impeller channel-to-channel, as depicted in Figure 1. This turbulent flow is always present and is often confused with "bubble" cavitation because it generates noise. Most pump handbooks assume uniform flow, although the actual flow does not even approximate these conditions.

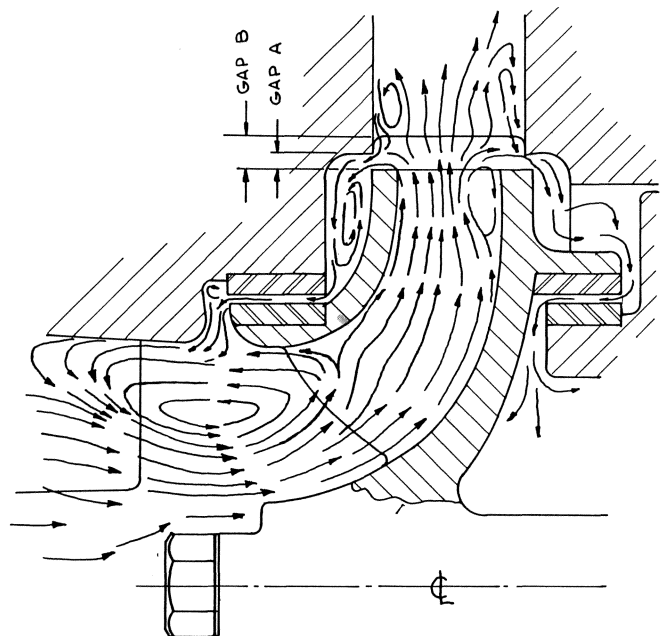

Figure 1. Interaction of Eddy Flow Pattern at Impeller Suction Eye and Vane Tips with Casing [1].

### *Impeller To Casing Clearances*

The interaction of recirculation at the impeller outlet or tip recirculation, at the suction eye, and with the casing itself, can be

very destructive to the pump performance. A complete understanding of this effect is not yet available. The low frequency axial vibrations that occur due to eddy flows around the impeller because of excessive impeller shroud to casing clearances, Gap "A," and suction recirculation are very complex. Flow disturbances related to suction recirculation and cavitation are always present in both diffuser and volute type pumps. If impeller diameters are reduced from the maximum, the flow distribution pattern across the exit width of the impeller becomes more unstable and the tendency for the high pressure liquid to return to the low pressure side and create tip recirculation is greatly increased. The higher energy level pumps are of major concern (above 200 hp and 900 ft of head per stage).

Careful machining of the volute or diffuser tips to increase gap "B," impeller vane tip to volute tongue or diffuser vane, while maintaining gap "A," has been used for a number of years to reduce the vane-passing frequency vibration greatly. The pulsating hydraulic forces acting on the impeller can be reduced by 80 to 85 percent by increasing the radial gap "B" from 1 percent to 6 percent. There is no loss of overall pump efficiency when the diffuser or volute inlet tips are recessed; contrary to the expectations of many pump designers. The slight efficiency improvement results from the reduction of various energy-consuming phenomena: the high noise level, shock, and vibration caused by vane-passing frequency, and the stall generated at the diffuser inlet.

Recommended dimensions [1] are given in Table 1 for the radial gaps of the pump impeller to casing.

RULES OF THUMB	
Valve stems and tee branches should be installed perpendicular to the pump shaft not parallel to the shaft.	
Piping should have at an absolute minimum of five pipe diameters of straight run before the suction flange.	

Table 1.

RECOMMENDED RADIAL GAPS FOR PUMPS				
TYPE PUMP DESIGN	GAP "A"	GAP "B"*- PERCENTAGE OF IMPELLER RADIUS		
		Minimum	Preferred	Maximum
Diffuser	50 mils	4%	6%	12%
Volute	50 mils	6%	10%	12%

$$*B = 100 \frac{(R^3 - R^2)}{R^2}$$

R<sup>3</sup> = Radius of diffuser or volute inlet

R<sup>2</sup> = Radius of impeller

NOTE: If the number of impeller vanes and the number of diffuser/volute vanes are both even, the radial gap must be larger by about four percent.

*Random Positioning of Impellers*

In the diffuser style pump, a complete set of hydraulics can be created specifically for each pump application, because the diffusers are cast separately from the case and the vane angle and location can be readily changed. In the volute design, the volutes

can be relocated only by a very expensive pattern change. In multistage volute pumps the degree of positioning of the volutes is severely limited by case design. It is necessary to randomly cut the keyways in the impellers to assure that vanes on adjacent impellers are not aligned and do not pass volute tongues simultaneously. Frequently, this random keyway positioning is not done when manufacturing the impellers and the vanes on the impellers line up, producing a high vane passing frequency vibration. The alignment of impellers and volutes in each stage should be carefully observed during witness testing and reassembly on a new pump or when replacing the impellers during maintenance.

*Three Pumps Operating In Parallel—A Case History*

The original design of a resid hydro unit called for two hot bottoms pumps to be run in parallel for rated throughput. A third pump was provided as a spare. As the unit throughput was increased further by debottlenecking activities, more flow through the pumps became necessary. The answer seemed to be to run the third pump full time. Immediately after adapting this practice, all three pumps began to make noise, vibrate, and the actual flow from all three pumps decreased below what was obtainable using just two pumps. The initial concern was that the suction piping design was inadequate and choking the flow to the pumps causing an NPSH<sub>A</sub> problem. However, a detailed design review indicated no problem in this area. Suction strainers were checked and even removed for a trial. No help for the problem was forthcoming. A review of the hydraulic performance of the pumps was conducted. The results showed that when the three pumps were put in parallel, discharge piping and system resistance forced all the pumps back on their curves to less than 50 percent of their BEP flow. Since these were low NPSH<sub>R</sub> (high suction specific speed or N<sub>ss</sub>) pumps, severe suction recirculation resulted causing the noise, vibration and reduced flow. The final solution was to replace the pumps with higher head pumps that also provided the necessary increased flow.

*Cooling Water Pumps—A Case History*

Cooling tower circulating water pumps typically are operated in parallel. These are normally high flow, high horsepower pumps with relatively high suction specific speed (N<sub>ss</sub>). A subtle problem arises in areas of the country where there are large swings in ambient temperatures from day to night (typical of the Gulf coast area in the late fall to early spring). Operating personnel will increase cooling water flows to heat exchangers during the day, adding additional pumps as necessary. However, as nighttime approaches and the cooling load is gradually reduced, the operating personnel pinch down on the water flows to the exchangers. Very seldom are unnecessary cooling tower pumps secured. This frequently results in all pumps being run in parallel and back on their H-Q curve to the point where suction recirculation occurs. Continued operation in this mode may result in premature failure of the pump bearings, impellers and, in extreme cases, the casing.

**PUMP DESIGN—MECHANICAL PROBLEMS**

Pumps can have mechanical design troubles. Bearing problems are frequently encountered. Centrifugal pump bearings may be antifriction bearings, ball or roller types; sleeve-type journal bearings; or hydrodynamic type thrust bearings. Antifriction type bearings are designed to handle a combination of both radial and axial thrust loads. Antifriction bearings are more popular in small to medium sized pumps. The ball bearing is a piece of precision equipment manufactured to extremely close tolerances. Cleanliness, accuracy, and care are required when installing ball bearings. Maintenance of ball bearings is simple; protect the bearing from contaminants and moisture and provide proper lubrication.

*Bearing Loads*

The life of a ball bearing is dependent upon the load it must carry and the speed of operation. The loads on pump bearings are imposed by the radial and axial hydraulic forces acting on the impeller.

In any two-bearing system, one of the bearings must be fixed axially, while the other is free to slide. This arrangement allows the shaft to expand or contract without imposing axial loads on the bearings, and yet definitely locates one end of the shaft relative to the stationary parts of the pump. The outboard bearing of between bearings design pumps or the closest one to the coupling on a back pull out design, generally is fixed axially. Failure to permit the one bearing to be free to slide within the housing bore to accommodate the thermal expansion and contraction of the shaft is a frequent problem.

Since one bearing is fixed in the housing, it must carry the axial thrust in addition to radial thrust. The axial thrust is considered to be acting along the centerline of the shaft and, therefore, is the same at the fixed bearing as it is at the impeller. The radial and axial loads combine to create a resultant angular load at the fixed bearing. Radial thrust acting on the impeller creates radial loading on both bearings.

The care and feeding of ball bearings is not discussed by the pump manufacturer in his manuals or in most pump handbooks. A new discussion of the applications of antifriction bearings and their lubrication in centrifugal pumps was published in 1993 [2]. It is well written and can be obtained from a local bearing supply house. It will be an aid in solving many of your bearing problems.

**HOT SERVICE PROCESS PUMPS**

The results of a study presented by Heald and Penry [3] indicates that several long standing basic concepts of the pump industry about pump thermal growth must be revised. Little notice has been taken of this study by industry or users, yet it contains some of the most significant information in decades for efforts to improve the reliability of hot service pumps. Currently, most single-stage, double-suction pumps are warmed by a bypass stream flowing from above the block valve through the discharge nozzle back to the suction pressure level (Figure 2). This warming flow “short circuits” and the main flow simply goes across the top pump casing. The casing is heated unevenly, with large temperature differentials between the top and bottom. This causes severe shaft sagging along with bowing or humping of the case (Figure 3). The rotor will then bind. If cold gas oil flush (petroleum distillate boiling between kerosene and lubrication oil fractions) is supplied

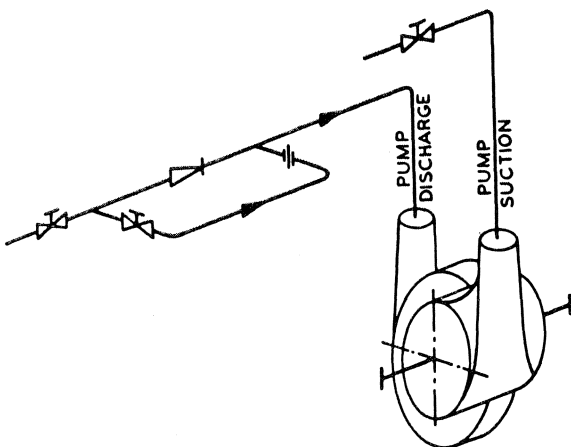

Figure 2. Normally Used Warmup Piping Showing Top Connection [3].

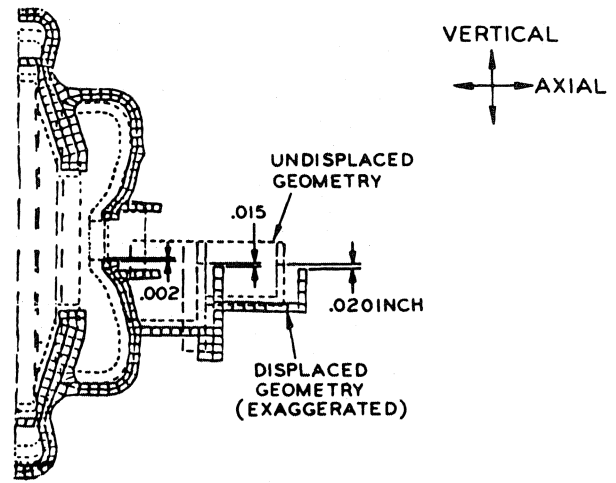

Figure 3. Casing Displacements Resulting from Top Warmup Flow Which Actually Added to Distortion [3].

to the mechanical seal glands, the seal and seal chambers are cooled while the rest of the pump is being heated. This results in stratification of cold gas oil in the bottom of the case and additional temperature differentials.

The warming stream flow patterns and rates must be carefully arranged to reduce the temperature differentials across the case of pumps in hot service. Recommended piping revisions from the paper are shown in Figure 4. The thermal expansion guiding designs or dowelling of the case must also be revised. A summary of suggested changes is as follows:

- Pumps larger than 8.0 in suction size should not be dowelled, as per current standard practices.
- Centerline keys that permit free radial and axial expansion towards the driver should be used in larger (> 8.0 in suction) pumps.
- Three bottom connections—one in the volute and one in each suction passage—should be used with the warming stream flowing out the suction nozzle to the suction vessel. Piping of at least 1.0 in diameter should be used to insure adequate flows (Figure 4).

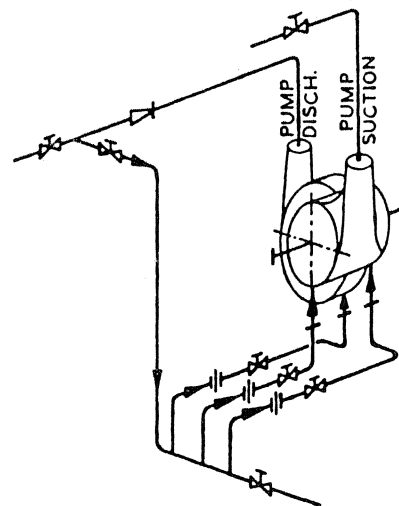

Figure 4. Improved Warmup Piping Into Bottom of Each Casing Passage [3].

- Tangential entry of the warm up fluid stream can go a long way toward reducing the stagnant areas within the pump.
- At temperatures greater than 500°F, extreme care must be taken to ensure that all auxiliary piping be welded to the case, and the case rough machined, *prior* to final heat treatment. This will prevent distortion due to stress relieving by temperature cycles in service.

*Warming Stream Flows*

Total warmup time for a single stage, double suction, pump from “cold” to “hot standby” varies from approximately two hours to as much as eight hours. Due to variations in pump installations that affect warmup, it is not possible to predict total time nor to prescribe accurate values for warming stream flow rate. Warming stream rates are tabulated in Table 2, as recommended by one pump vendor. These values are a minimum and will require adjustment for a given installation.

Table 2.

Pump Discharge Nozzle Size (In)	WARMING UP FLOWS		
	Operating Temperature vs.		
	Warming Stream Flow Rate (GPM) Per Pump 200°F	450°F	700°F
4 - 6	4	5	6
8 - 10	5	6	7
12 - 14	6	8	10
16 - 18	7	10	13
20	8	11	14

*Hot Service Pump Castings—A Case History*

Three new hot (700+°F) service, between bearing-type, single-stage, pumps developed mechanical seal leakage problems shortly after initial startup. The first thoughts were centered on a seal design problem and/or excessive piping forces causing casing distortion. A detailed review of the piping flexibility and field installation was conducted without finding any problem. After repeated rebuilds of the mechanical seals, operating supervisors decided to convert one of the pumps to packing as a reliability move. When the pump was shopped for this conversion, it was discovered that the casing bore was no longer round, the end cover fits were not parallel, and the bearing brackets were not in alignment. All surfaces were reclaimed to proper tolerances, assembled, reinstalled, and put on line without any mechanical seal problems. The other pumps were similarly rebuilt with good results to correct almost identical distortions. The purchase order called for these alloy cases to be heat treated prior to final machining. However, the manufacturer could not produce the documentation indicating that this had in fact been done.

*Cooling Water To Pumps—A Case History*

How much cooling water and where should it go on a hot service pump is a continuing question. A hot service pump was equipped with mechanical seals that were flushed with cooled product using a small cooler provided by the pump manufacturer. During startup, the unit operators were unable to adjust the output flush temperature low enough to provide required cooling to the seal. The first corrective action was to replace the exchanger with a shop fabricated sample cooler (a piece of pipe closed at one end with a coil of tubing in it). Flush fluid is circulated through the coil, while fresh water is used to submerge the coil and is allowed to overflow

to the unit sewer system. This is a tremendous waste of water, not to mention the cost of effluent treating. A detailed review of the installation, conducted later, uncovered the real problem. The cooling system supplied by the pump manufacturer was designed for a minimum pressure differential of 15 psi between the supply and return flanges. The cooling water supply and return headers at the pump location on the unit provided at least that amount of differential. However, between the pump and the headers, the installation contractor, had run, for a considerable distance, only 1/2 in pipe. The pressure drop in these lines provided only a 5.0 to 8.0 psi differential between the supply and return nozzles at the pump. Replacement of the too small piping with larger piping reduced the pressure drop and cured the cooling problem.

*Water Cooled Bearing Housings—A Case History*

Shortly after being put on line, a turbine driven, hot bottoms pump failed resulting in a very damaging, expensive fire. Investigation of the pump found that the ring-oiled rolling element pump bearings had failed as a result of corrosion. The pump, normally kept in standby service, was driven by a small topping steam turbine and was equipped with bearing housing cooling coils. The housing was also equipped with typical lip-type end seals. Inspection of similar installation on the same unit found other bearings with excessive corrosion damage. Cooling water to the pump bearing housing, which is required to cool the bearing oil sump during normal operations, was not secured when the pump was placed in standby. The basic cause of the failures was that the steam turbines were kept warm by bleeding exhaust steam into the casing. However, the turbine carbon end seal leakage allowed steam to blow out the coupling end toward the pump bearing housing. Steam leaking past the turbine end seals condensed in the pump housing and on the bearings themselves, causing the corrosion damage. The three fold solution to the problem was to:

- reduce the amount of steam used to keep the turbine warm,
- add better end seals to the bearing housing, and
- secure the cooling water to pumps when on standby.

An alternative solution to the second and third steps would have been to equip the pump with a pressurized oil mist lubrication system and dispense with the cooling water to the pump bearings.

**IMPELLER TRIMMING—HYDRAULIC ASPECTS**

With the rotational speed held constant as is done with most pumps, “affinity laws” calculations generally dictate more of a cut of the impeller diameter than required to effect the desired head and flow reduction. The errors can be substantial. If the calculated trimming calls for a 10 percent reduction in diameter, only a seven or eight percent reduction should be made. The hydraulic effects of impeller trimming on pump performance depend very much on the *specific speed* of the impeller. This term classifies the hydraulic features of pump impellers as to their type and proportions. Most refinery pumps fall between about 900 and 2,500 on this index, as shown in Figure 5. Some vertical multistage pumps are in the 4,000-6,000 range. The lower the value of the specific speed

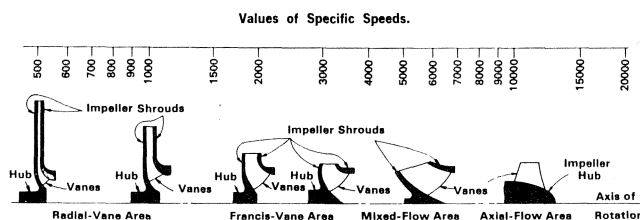

Figure 5. Specific Speed Vs Impeller Types [6].

of the impeller design and the larger the impeller cut, the larger the discrepancy in the affinity laws.

There are several reasons for the actual head and flow of a trimmed impeller being lower than that calculated.

- the effect of a recirculation or other disturbance in the inlet can transfer rapidly to the outlet of the impeller because of the shorter vane length.

- The “affinity laws” assume that the impeller shrouds are parallel. In actuality, the shrouds are parallel only in lower specific speed pumps such as boiler feed pumps.

- The impeller has control of the liquid for a shorter length of time.

- The liquid exit angle and vane length is altered as the impeller is trimmed so the head curve steepens slightly.

- There is increased turbulent flow at the vanes tips, because the outlet channel widths are altered and if shroud to casing clearance or Gap “A” is not maintained.

All of these effects contribute to a reduced head development and flow after an impeller is trimmed. Pumps of mixed flow design are more susceptible to problems than the true radial flow impellers found in higher head pumps. More caution has to be exercised in altering the diameter of a mixed flow impeller. Impeller diameter reductions for radial designs should be limited to about 70 percent of the maximum diameter design. While this subject is not discussed in most pump handbooks, it is covered in the literature [4, 5].

Diameter reductions greater than about five to ten percent will increase  $NPSH_R$ . This increased pump  $NPSH_R$  occurs because specific vane loading is raised by the reduced vane length, effecting velocity distribution at the impeller inlet. Not all pump companies consistently show the increased  $NPSH_R$  with reduced impeller diameters on their pump curves. A great deal of attention must be paid to this factor when the margin between  $NPSH_R$  and  $NPSH_A$  is very narrow or the  $NPSH_R$  for a pump is extremely low.

#### IMPELLER TRIMMING—MECHANICAL ASPECTS

When trimming an impeller from its maximum diameter to adjust the head and flow developed by a centrifugal pump, questions often arise: What is the best way to cut the impeller? Is it best to trim the impeller vanes *and* the shrouds or just the vanes?

No hard and fast guidelines for the mechanical aspects of impeller trimming exist, but there several pump construction and hydraulic design factors to consider while making the decision of what to trim. How the impeller is trimmed will greatly influence the hydraulic performance of the pump as well as the vibration levels experienced. An evaluation of hydraulic characteristics is necessary before deciding how to trim the impeller.

For volute type pumps, the entire impeller, vanes and shrouds *may* be cut, as shown in Figure 6. However, this will increase the axial vibration and other problems associated with Gap “A”

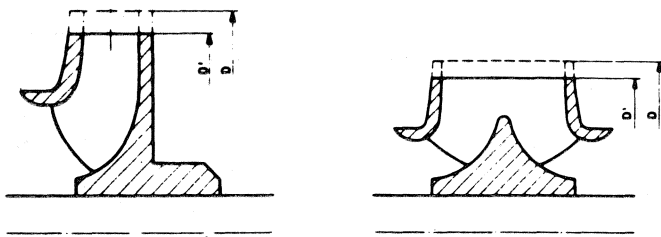

Figure 6. Impeller Reduction Methods—Reduction of Shrouds and Vanes [4, 7].

(shroud to case clearance) due to the uneven flow distribution at the impeller exit area. The double suction impeller type pump is especially sensitive to problems caused by increased Gap “A,” so trimming the entire impeller is not a good choice. It is best to cut the impeller vanes obliquely as shown in Figure 7, leaving the shrouds unchanged or cut the vanes only as depicted in Figure 8. Trimming the vanes only tends to even out the exit flow pattern and reduce the recirculation tendencies at the exit area. Gap “A” should be about 0.050 in (radial) for minimum vibration because of the “vane passing” frequency.

In most diffuser type pumps, it is best to trim only the vanes, as shown in Figure 8, in order to control tip recirculation and the ill effects of an increased “Gap A.” This cut yields a more stable head curve because the tendency for tip recirculation and the possibility

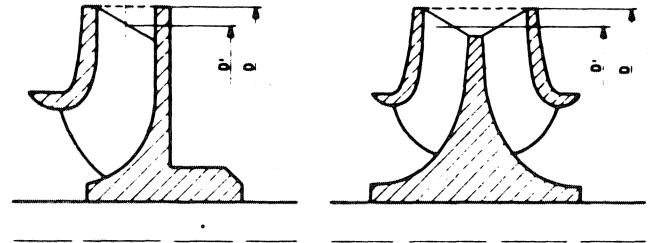

Figure 7. Impeller Reduction Methods—Oblique Cuts of Vanes Only to Maintain “Gap A” [4, 7].

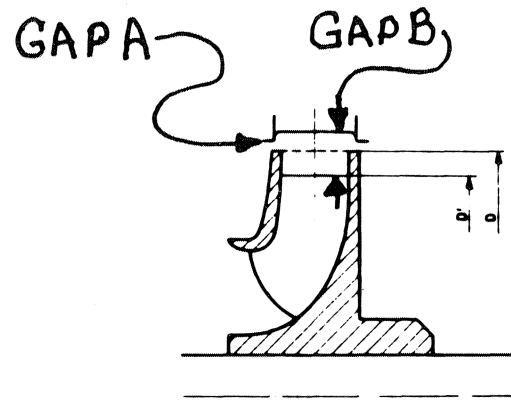

Figure 8. Impeller Reduction Methods—Cutting Vanes Only to Maintain “Gap A” [4, 7].

of suction recirculation being established is greatly reduced due to a more uniform flow distribution at the exit area.

Structural strength of the shrouds is a factor in the decision as to how to trim the impeller. There may be too much unsupported shroud left after a major reduction in diameter. The oblique cut leaves the shrouds unchanged and solves the structural strength problem as well as improving the exit flow pattern.

#### Trimming An Impeller—A Case History

As discussed previously, trimming an impeller increases the  $NPSH_R$  of the impeller pattern because of the shortened vane length. A trimmed impeller, delivering the same flow against a lower discharge head, can need higher  $NPSH_R$ . Even if the trimmed impeller operates a lower capacity corresponding to the new BEP, the  $NPSH_R$  will be higher than for the full sized impeller. This rarely discussed fact must be taken into account when evaluating the need to trim an impeller to adapt it to changed system needs. An impeller that was trimmed by about 22 percent to correct the misapplication in a new installation is shown in Figure 9. The





Figure 9. Fatigue Failure of Impeller Due to Turbulent Flows Caused by Several Installation Errors.

$NPSH_A$  was already marginal. The trimming increased the  $NPSH_R$  of the impeller. Also, the sharp edges left by the trimming of the vanes and shrouds were not radiused as they should have been. In addition, the suction piping to the pump had a welded reducer with the flat side on top and the liquid source above the pump centerline. This created severe turbulent flow into the impeller, further compounding the marginal ratio of  $NPSH_A$  to  $NPSH_R$ . The turbulent flow continued through the length of the impeller vanes. The pressure pulsations of the tip recirculation effects caused a fatigue failure of the stainless impeller. The resulting vibrations caused a seal blowout and a major fire. There were fatigue cracks in the impeller shroud near the other three vanes. The failure mechanism is similar to those encountered by too tight a Gap “B” clearance (Figure 10).

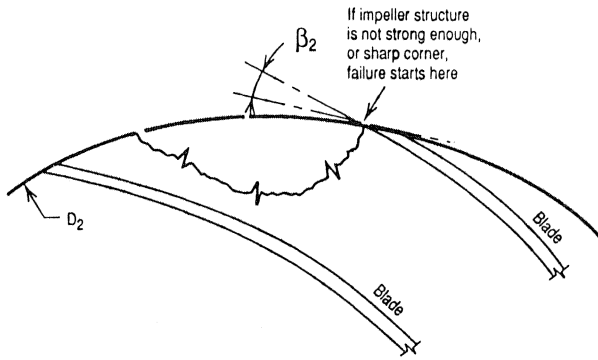

Figure 10. Fatigue Failure of Impeller Due to Pressure Pulsations from Improper Radial Clearances [1].

**SUCTION PIPING DESIGN**

Because of  $NPSH_A$  considerations, the suction piping design requires a more accurate evaluation than the discharge piping. Most engineering contractors design new units by establishing plot layouts and vessel heights first. They then do estimated system sketches using assumed piping diameters to establish preliminary hydraulic requirements in order to be able to get quotes for the pumps. Quite frequently, pumps are selected and purchased before the final hydraulic conditions are established. The result is all too often, a suction piping system that puts the reliability of the pump in jeopardy right from the start. Improperly sized and tortuous flow paths of suction piping can be disastrous. Oversized pipe, with corresponding reducers, must be used to reduce friction losses.

Valves, strainers, and other fittings are frequently “stacked” on top of the pumps with insufficient runs of straight pipe before the suction nozzle. The ideal solution is to establish the final hydraulics before pump selection and to establish the vessel height after the pump is selected. Piping and vessel skirts are very inexpensive compared to a lifetime of increased maintenance costs of the pumping system.

The suction piping sizing and design are based on several criteria. However, the basic consideration normally is line velocity of the liquid. Velocities and pipe sizing should be based on rated flow. Friction drops and the flow paths in the piping must also be considered. Remedial action to correct poorly designed suction piping is costly. Therefore, it is important to avoid any problems in the first place.

Suction line velocities computed at the flange diameters should be kept low. A streamline flow, without serious discontinuities, is more important. There are few guidelines as to the effect of the various fittings on the flow pattern proper. The users are left to their own devices to design the suction piping configuration.

One of the best ways to begin to design suction piping is to make a schematic drawing of and tabulate the conditions of the system. Figure 11, one sketch out of an extensive discussion of piping systems for several types of pump applications and installations [4], is of a tower feed system with multi-series branches with normal liquid level greater than the margin.

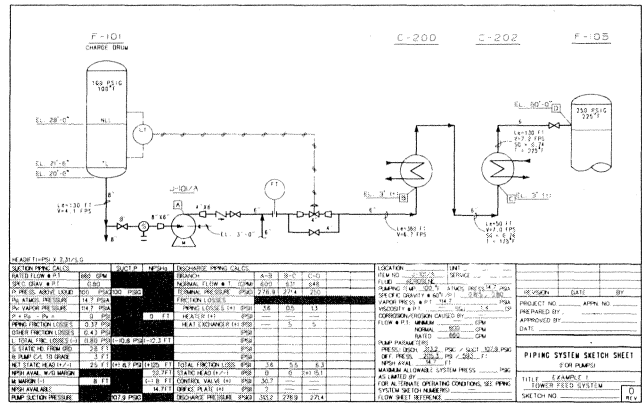

Figure 11. Tower Feed System with Multi-Series Branches with Normal Liquid Level Greater Than the Margin [4].

**Factors In Suction Piping Layout**

The increasing use of CAD systems for designing piping has all too often determined a suction piping configuration that will solve a differential thermal-expansion problem, or fit in the limited space of a piping rack, but adversely affects the liquid flow in the suction piping. Greater utilization of packaged or skid mounted component systems has further reduced the room for straight runs of suction piping. A generally accepted guideline is that pump suction block valves must be one size larger than the pump nozzle but not larger than the line size. Suction piping is generally one or two sizes larger than the pump suction nozzle. Suction piping, which is not straight for a suitable distance upstream of the pump, can cause trouble. Most pump manufacturers recommend a straight run of ten pipe diameters for the suction piping before the pump. Five pipe diameters of straight run piping are considered to an absolute minimum. In the utilities industry, suction piping has been such a major problem in boiler feed pumps that 40-pipe-diameters of straight run are frequently specified.

A simplified and useful rule of thumb would be to have about one foot of straight run piping for each foot per second of liquid

velocity in the suction line. The use of CAD systems, economic pressures, and a lack of available space frequently do not allow the pipe designer this design option. All of these factors combine to create pump problems for the user.

Flow disturbances can be especially harmful to double suction impellers. Good practices that may be used to reduce these problems on the suction piping include:

RULES OF THUMB	
1.	Generally the suction piping is one or two pipe sizes large than the pump nozzle. Suction lines should not be smaller than the sump suction nozzle.
2.	To prevent cavitation in the pump, suction line velocities should not exceed 10 ft./sec. unless there is a substantial length (at least seven pipe diameters) of straight pipe immediately upstream of the pump. Consider 5 to 6 ft/sec. maximum for new systems.
3.	The pressure drop across permanent suction strainers must be considered.

*Layout Of Suction Piping*

Most pump hand books published in the U.S. “borrow” some venerable (over 60 years old) illustrations from the Hydraulic Institute Standards [6] to show what the suction piping layout should be. The illustrations concern themselves with the location and orientation of reducers and elbows in horizontal planes as shown in Figures 12 and 13. The illustrations are intended to depict “good” and “bad” installation practices and have come to be considered the last word on the subject. In some cases, these “good” practices indicate that the reducer fittings should be installed in a manner that will harm the suction conditions. The sketches are taken out of context. The impression is given that an eccentric reducer should ALWAYS be used and the flat of the reducer should always be on top. The implied reasoning is the avoidance of vapor pockets in the suction piping. In actual practice, there are some fallacies in the reasoning implied by the Hydraulic Institute.

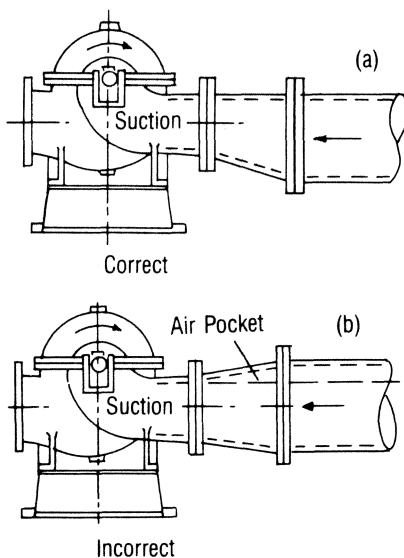

Figure 12. Reducer at Pump Suction. The implication is that the source of the liquid is below the pump centerline [6, 9].

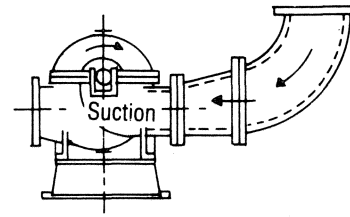

Figure 13. Eccentric Reducers Should Be Arranged with the Flat on Bottom When Source of Liquid Is above the Pump [9].

Some guidelines for the suction piping are:

RULE OF THUMB
STRAIGHT RUN SUCTION PIPING = ONE FOOT FOR EACH FOOT PER SECOND OF LIQUID VELOCITY

NOTE: FLOW VELOCITY BASED ON RATED FLOW.

A simpler rule of thumb, suitable for evaluation purposes, is:

RULES OF THUMB - REDUCERS	
Reduction - in one reducer - one pipe size	
Greater reduction - use fabricated reducer with 10° maximum included angle.	

*What Is A Reducer?*

To a pump designer, a concentric reducer is a cast fitting with an convergence angle type included angle of 10 degrees [7, 8], that reduces the possibilities of forming large vapor-bubble clouds in the suction piping that could be carried into the pump impeller. The convergence continues over the entire length of the fitting. To a piping designer, a concentric reducer will be a wrought fitting. The wrought welding fitting type of eccentric reducer may not a good choice for use on a pump suction. The included angle is much greater than the 10 degrees desired by the pump designer. The length of the fitting is only a little over three quarters of the major diameter. The fitting is nearly an orifice plate with rounded edges.

RULES OF THUMB - REDUCER ORIENTATION	
SUCTION ABOVE C/L	ECCENTRIC - FLAT SIDE ON BOTTOM OR CONCENTRIC
SUCTION BELOW C/L	ECCENTRIC - FLAT SIDE ON TOP CONCENTRIC NOT RECOMMENDED

*Orientation Of Reducers?*

There are several ways to install reducers in the suction piping, depending on the location of the suction vessel with respect to the pump.

*Suction Vessel Below Pump*

When the suction vessel is located below the pump centerline such as an open pit sump, eccentric reducers should be installed flat side up as shown in Figure 12 (a) from the Hydraulic Institute. The slope of the piping should be away from the pump. This



arrangement minimizes the possibility of vapor pockets forming and stopping the pumping action as the pump becomes air bound. Concentric reducers as shown in Figure 12 (b) should be avoided in this situation.

*Suction Vessel Above Pump*

When the suction vessel is above the pump as occurs in most processing plants, the major flow is on the out side of the elbow as it enters the pump. The least flow disturbance occurs with the *flat side down*, as shown in Figure 13. The slope of the piping should be *toward* the pump. An eccentric reducer installed with the *flat side up* increases the turbulence in the area of the major flow and should be avoided. A concentric reducer would also be an acceptable choice for this situation.

*End Suction Process Type Pumps*

For this type pump and suction vessel above the pump, a concentric reducer is preferred as it generally creates the least amount of turbulent flow. The close proximity of the impeller eye to the suction flange means that any disturbance in the liquid flow is transmitted directly to the impeller. This fact requires the use of greater caution in piping design.

**ELBOWS—WHICH ORIENTATION?**

When a flowing liquid enters an elbow, tee or reducer, it tries to keep flowing in the same direction it was before entering the fitting. The “streamlines” of the flowing liquid are displaced and develop both higher velocities and higher pressures than that existing just before entry into the fitting. Inertia of the moving liquid theoretically forces the liquid against one side of an elbow, as shown in Figure 14. Both high velocity and high pressure tend to develop on the out side of each turn. The secondary flows are at right angles to the pipe axis even though the main flow is in the direction of the axis. The friction resistance of the pipe walls and some centrifugal forces combine to produce the liquid rotation. A flow pattern similar to that shown in Figure 15 is produced. Vortexing and vapor pockets are created.

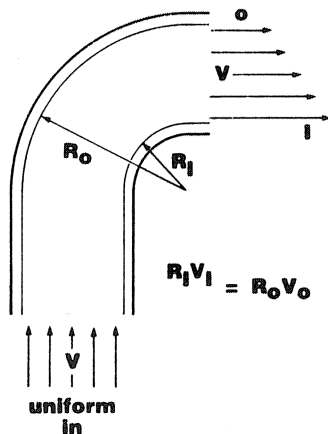

Figure 14. Theoretical Flow Velocities in an Elbow.

The effects of a single elbow mounted in a plane parallel to the shaft of a double suction pump are illustrated in Figure 16 [4, 13]. One side of the impeller cavitates while the other side experiences very high flows. The same effect can be caused by a suction block valve whose stem is parallel to the pump shaft (Figure 17). Many handbooks indicate that if the elbow is rotated to 90 degrees from the shaft as shown in Figure 18, everything is lovely. This is not always true. If successive turns are made in planes at right angles

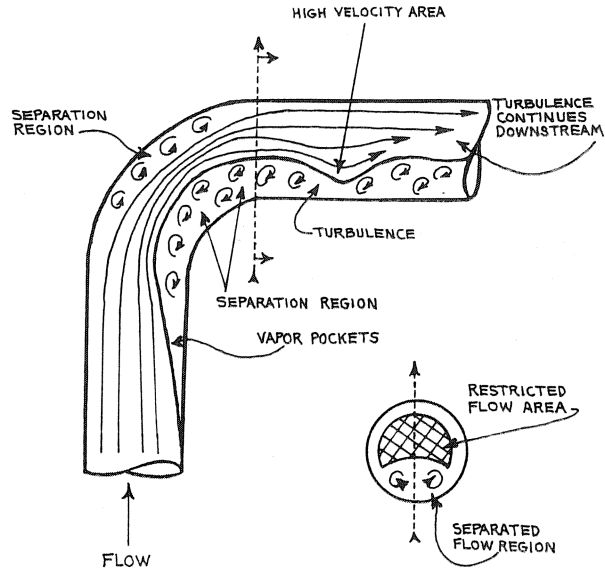

Figure 15. Actual Flow Streamlines in an Elbow.

to each other (Figure 19) [11], the high-velocity streamlines flow circumferentially around the inside the pipe, producing a turbulent flow pattern like that discussed before and shown in Figure 15. This turbulence distorts the piping velocity profile, producing a ring of higher velocities near the pipe wall and lower velocities in the center of the piping. When there is not enough straight run pipe *after* the second turn, the turbulence is swept into the impeller eye. Severe suction recirculation will occur as a result.

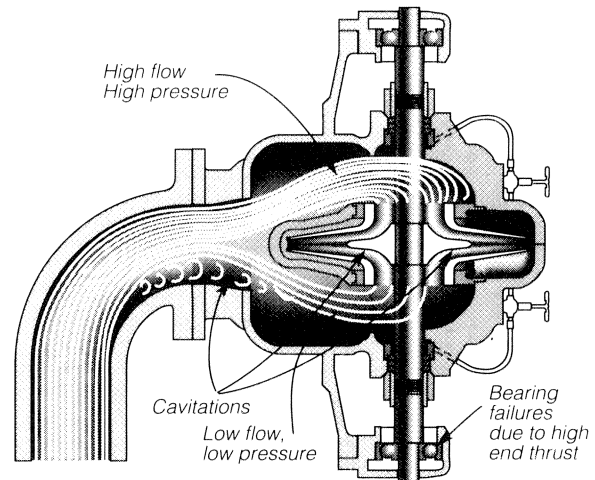

Figure 16. Undesirable Effects of an Elbow Placed in a Plane Parallel to Pump Shaft [4, 13].

If there are two elbows on the inlet of a double suction pump, most of the liquid initially enters the one side of the impeller while the other impeller starves as the vapor-bubble enters. The impeller eye pressure diminishes and that side of the impeller cavitates. The liquid entering the pump diverts to low pressure area, satisfying the starved eye of the impeller. The other side of the impeller then starves and cavitates. The cycle repeats several times per minute.

Two or more elbows installed in series and different planes produce multiple distortion and a swirl in the flow entering the pump. If the suction vessel is above the pump centerline, piping

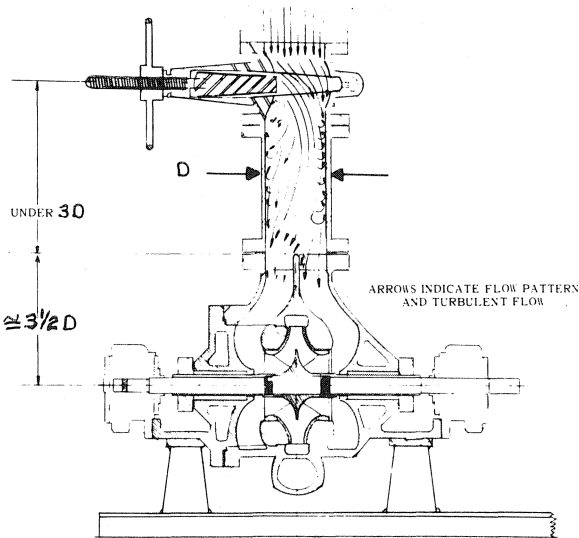

Figure 17. Same Effects As in Figure 16 from Valve Placement [4].

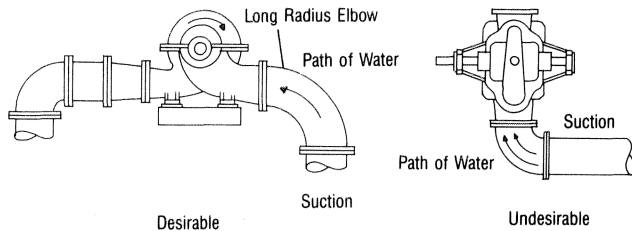

Figure 18. Recommended Placement of Elbow at Suction. The implication is that the source of the liquid is below the pump centerline and vertical positioning of elbow cures all ills [6].

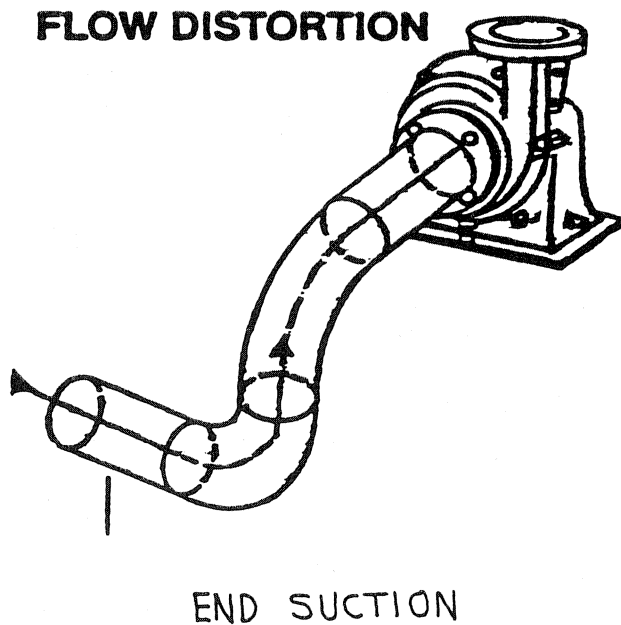

Figure 19. Flow Distortion Produced by Elbows Placed at Right Angles to Each Other. Liquid source below the pump centerline [11].

configurations such as those shown in Figure 20 can create suction problems and should be avoided.

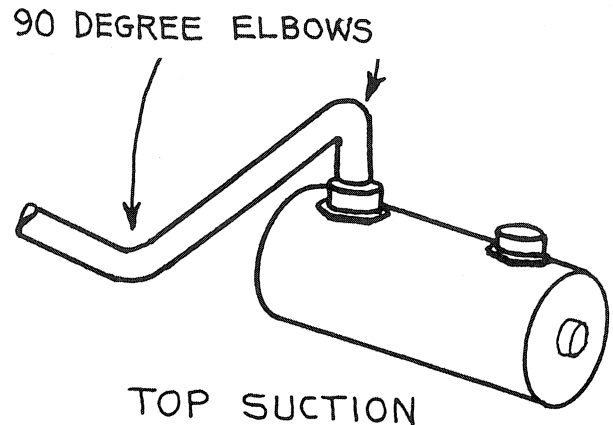

Figure 20. Flow Distortion Produced by Elbows Placed at Right Angles to Each Other. Liquid source above the pump centerline [11].

Relocating the piping to permit only one elbow in one plane is the best solution. If this is not practical, then placing the elbows in planes 45 degrees apart is better than elbows that are 90 degrees apart. One pump handbook [7] recommends the use of turning vanes (called fins in the handbook) in the elbows and a minimum of seven straight pipe diameters before the suction flange of the pump to improve the flow symmetry.

Alternative Designs

As the problems caused by poor suction piping designs have increased, alternative designs are beginning to emerge. One approach [7] is the use of turning vanes cast or welded in the fitting (elbow, tee, etc.). Proper placement of the vanes to correct the circular flow pattern can be difficult.

An other corrective device is a particular the rotary vane [13]. It consists of a stationary set of vanes installed directly ahead of an elbow. The multiple vanes change the rotation of the incoming flow to compensate for the turning effects of elbow geometry, as shown in Figure 21. Compare this flow pattern to the uncorrected one of Figure 16.

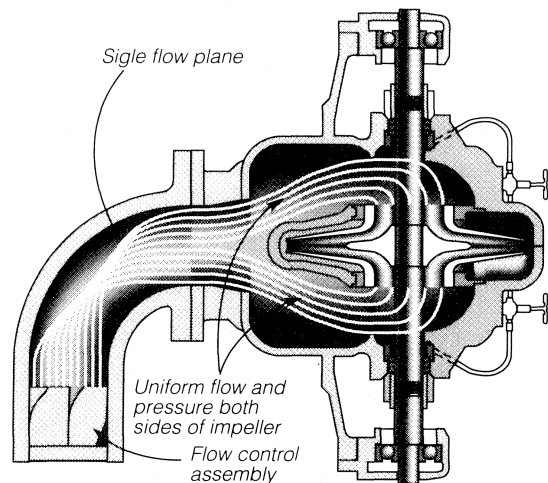

Figure 21. Flow Corrections Achieved by Patented Device. Compare flow patterns with Figure 16 [13].

One pump manufacturer has developed specially contoured cast elbows to improve the streamline flow pattern entering the pump suction [14]. Most piping designers have not utilized improvements such as the contoured elbow.

Frequently piping layouts are designed using short radius elbows and other readily available fittings. Some horrible designs that are frequently used and result in problems are shown in Figure 22. They should be avoided in favor of the recommended alternatives. In one instance, the lateral layout shown resulted in pump No. 1 being unable to operate in parallel with pump No. 2, because of inadequate suction flows. Krutzsch [15], although out of print, offers some excellent guidelines for piping layout.

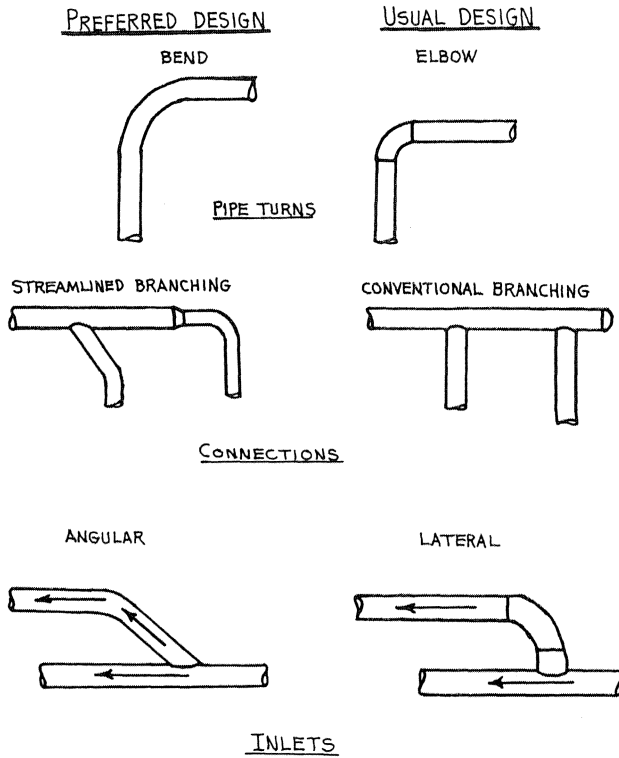

Figure 22. Undesirable and Recommended Piping Layout and Fitting Utilization.

**PIPE STRAIN DISTORTION OF CASE**

The case of a single-stage, double-suction pump is especially susceptible to pipe strain. If you look at an end view of the pump, it looks like the wishbone of a turkey, see Figure 23 [16]. Pipe strain tends to close the “wishbone” which in turn crushes the case wear rings in the vertical plane. In some pumps, the case supports are inside the outer dimension of flanges; then the pipe strain tends to open the “wishbone” and crush the ring in a vertical direction rather than the horizontal direction. This crushing action is one of the reasons for not relying on the dowel pins to position the bearing housings after an overhaul.

*Pipe Supports — Help or Hinderance?*

During a recent inspection tour of a unit that had just completed its initial startup, it was noted that over one-half of the spring hanger type piping supports still had their shipping clips installed, thus preventing movement of the hangers. While these mistakes were found and corrected before any damage could be done to the pumps, similar incidents have been observed on twenty year old units. Other problems of this nature include no permanent record

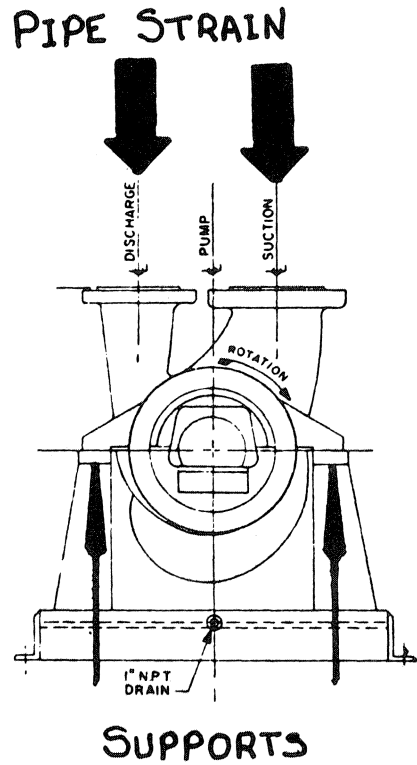

Figure 23. Casing Distortion of Single-Stage Pump Due to Pipe Strain [16].

of the required settings of the hangers. Who knows what effect excessive piping stresses has had on the equipment reliability?

*Pumps As Piping Supports—A Case History*

Years ago, when someone asked a pump manufacturer how much external forces and moments his pump could take without distorting the casing or losing internal and external alignment, the reply would normally be, “none.” Realizing that this answer was unrealistic, the American Petroleum Institute (API) 610 standard, Centrifugal Pumps for General Refinery Use [17], specified the minimum forces and moments to which a centrifugal pump should be designed to handle. These values were then to be used by the piping engineer as the maximum values his design could transmit to the pumps. However, the piping designer does not always know or take into consideration all operating or startup conditions. For example, three large cooling water pumps were recently installed in a Northern refinery, where it can be over 100°F in the summer and down to 30°F below zero in the winter. The piping designer put in thermal expansion loops in the suction piping to take care of any thermal movement. However, the installation contractor incorrectly tied the pipe down on both sides of the expansion loop. To make matters worse, instead of making the last piping weld at the flange next to the suction nozzle, the contractor “forced the piping” to meet the flange face. The results were, as the pipe warmed up and expanded, the pump casing was severely distorted to the point where the rotor seized.

**CORRECTION OF VIBRATIONS INDUCED BY HYDRAULICS**

“Vane passing” frequencies are frequently encountered during vibration analysis of a pump. The most effective method of reducing vane passing frequencies is to carefully maintain proper gap “A” and gap “B” clearances to reduce impeller-casing interac-

tion. On some occasions, even when the impeller O.D. is the correct distance from the cut water (Gap "B"), impellers manufactured with blunt vane tips cause disturbances in the impeller exit area and in the volute area by generating hydraulic "hammer." Corrections can be achieved by sharpening the vane tips by use of one of two methods.

- **Overfiling**—Vane pass disturbance may be partly or entirely eliminated by tapering the vanes by "overfiling" or removal of metal on the *leading* face of the vane, as shown in Figure 24. This technique has the additional advantage of restoring the vane exit angle to near that of the maximum impeller design before the diameter reduction.

- **Underfiling**—By sharpening the underside or *trailing* edge of the vane as shown in Figure 25, the outlet area of the liquid channel can be enlarged. This will generally result in about five percent more head near the best efficiency point, depending on the outlet vane angle. At least 1/8 in of vane tip thickness must be left. Sharpening the vanes also improves the efficiency slightly. Where there are high stage pressures, sharpening must be carried out with great care because of the high static and dynamic stresses on the vanes involved.

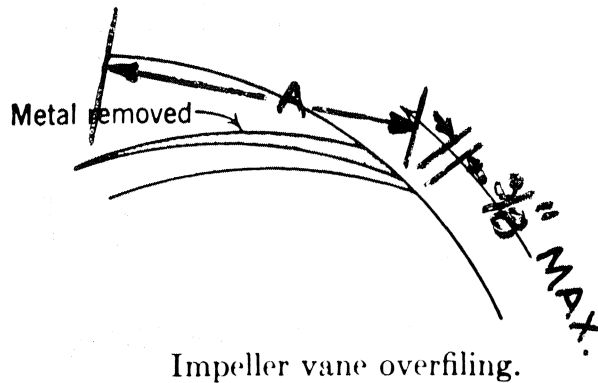

Impeller vane overfiling.

Figure 24. Impeller Vane Overfiling [4].

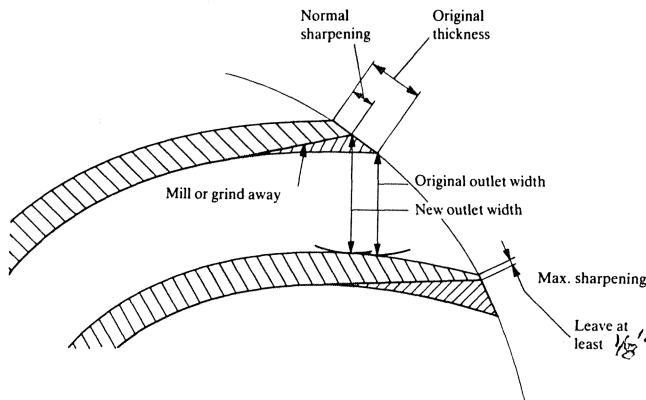

Figure 25. Impeller Vane Underfiling [4, 7].

## CONCLUSIONS

Many engineers consider a pump as an independent, or inlet flange to out flange, entity. A pump really exists as a part of a

system and as such, is heavily dependent on the design and construction of the other components. Considerable thought and effort must go into the engineering of these components as well as the pump. If considerable attention is not paid to certain details during the initial design and installation, then overall reliability of the pumping system will be lowered. Analysis and correction of the basic problems can be difficult after installation. Careful evaluations during the design phase are the most economic way of achieving pump reliability.

## REFERENCES

1. Makay, E. and Barrett, J. A., "Changes In Hydraulic Component Geometries Greatly Increased Power Plant Availability and Reduced Maintenance Cost: Case Histories," *Proceedings of the First International Pump Symposium*, The Turbomachinery Laboratory, Texas A&M University, College Station, Texas (1984).
2. SKF Staff, "Bearings In Centrifugal Pumps," Publication 100-955 (1993).
3. Heald, C. C. and Penry, D. G., "Design and Operation of Pumps for Hot Standby Service," *Proceedings of Fifth International Pump Users Symposium*, The Turbomachinery Laboratory, Texas A&M University, College Station, Texas (1988).
4. Dufour, J. W. and Nelson, W. E., *Centrifugal Pump Sourcebook*, New York, New York: McGraw-Hill (1992).
5. Lobanoff, V. and Ross, R. R., *Centrifugal Pumps—Design and Application*, First Edition, Houston, Texas: Gulf Publishing Company (1986) (Second Edition available).
6. "Hydraulic Institute Standards for Centrifugal, Rotary and Reciprocating Pumps," Hydraulic Institute, Thirteenth Edition, (Sixteenth Edition available).
7. *Sulzer Centrifugal Pump Handbook*, Sulzer Brothers Limited, Winterthur, Switzerland (1986).
8. *Cameron Hydraulic Data*, Ingersoll-Rand, Phillipsburg, New Jersey, Sixteenth Edition, pp. 1-25, 3-116 to 3-122 (1984) (Seventeenth Edition now available).
9. Karrassik, Igor J., "Installation of Centrifugal Pumps, Parts I and II," *Chemical Processing* (February-March 1989).
10. Karassik, Igor J., "Operation of Centrifugal Pumps, Parts I and II," *Chemical Processing* (April-May 1989).
11. McGuire, J. T., "Avoiding Centrifugal Pump Problems," *Plant Engineering*, pp. 66-68 (March 8, 1990).
12. McGuire, J. T., *Pumps for Chemical Processing*, New York, New York: Marcel Dekker, Inc. (1990).
13. "Application Bulletin Pump Protection," Cheng Fluid Systems, Sunnyvale, California (1992).
14. Doolin, J. H., "Special Elbow Design Solves Pump Piping Problem," *Power & Fluids*, 10 (3) pp. 12-13 (1984).
15. Krutzsch, W. C., "Hydraulic Design Considerations For Pump Suction Piping—Part I," *Power & Fluids*, 8 (4), pp. 10-15 (1982); "Part II," *Power & Fluids*, 9 (3), pp.10-15 (1983).
16. Nelson, W. E., "Hot Service Pump Alignment Troubles," *Chemical Processing*, pp. 23-30 (December 1989).
17. "Centrifugal Pumps For General Refinery Services," API Standard 610, Seventh Edition (1989).