

SELECTION OF LUBE OIL SYSTEMS COMPONENTS FOR PROCESS PUMPS AND AUXILIARIES (EXTERNAL, PRESSURIZED)

by

Vinod P. Patel

Senior Principle Engineer, Machinery Technology

M.W. Kellogg Company

Houston, Texas

and

Donald G. Coppins

President

Lube-Power, Inc.

Shelby Township, Michigan



Vinod Patel is a Senior Principal Engineer, Machinery Technology, for the M.W. Kellogg Company, in Houston, Texas. In this assignment, he is responsible in the preparation and auditing of specifications, equipment evaluation, engineering coordination, and testing and installation startup of rotating and special equipment. He has worked in the various application of rotating machinery in the petrochemical and refinery processes including ammonia,

LNG, olefins, cat cracking, and hydrotreating for domestic and international projects.

Mr. Patel received B.S. and M.S. degrees in Mechanical and Metallurgical Engineering from M.S. University, and Youngstown University, respectively. He is a registered Professional Engineer in the State of Texas.

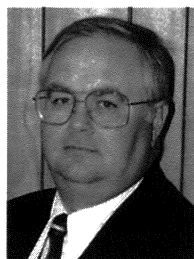

Donald G. (Don) Coppins designs and manufactures oil lubrication systems, seal oil systems, seal buffer systems, heat exchangers, and hydraulic systems for the petrochemical, refining, power generating, and process industries. He has 29 years experience in the oil hydraulic and lubrication systems business. Mr. Coppins started and developed products for: Lube-Power, Inc., Chesterfield, Michigan; Seal Pots, Inc., Tulsa, Oklahoma; and DC

Hydraulics, Canton, Michigan. The emphasis is on production of the highest quality systems with on time delivery. He performs administrative, quality, and code vessel engineering functions at Lube-Power, Inc.

Mr. Coppins holds multiple technical and business degrees including: AAS for Mechanical Production Technology, from Oakland, California; BSME, DIT, and BBA Management/Marketing, all from Michigan colleges.

Conservative design and proper specifications minimize the possibility for failure and maximize the potential for long, trouble-free service life of the rotating equipment. Understanding the system's needs, optimizing component selections, allowing for operational maintenance, and proper application of the system are the keys to reliability.

INTRODUCTION

The pump user's objective is to maximize revenue from his process. In order to meet this objective, it is extremely important to have safe and reliable operation of pumps and auxiliaries.

Larger process pumps and drivers often use hydrodynamic bearings, due to required bearing load and their noted reliability over antifriction bearings at higher bearing surface velocity. The oil film that forms in the hydrodynamic bearings provides the needed separation between shaft and bearing. This continuously replenished oil film removes bearing heat and wear particles.

The oil film properties are a function of many things including oil viscosity, bearing/shaft clearance, bearing load, etc. Constant oil supply within the acceptable temperature and pressure range is required to keep the bearing system in balance. A loss of oil supply means a loss of cooling, loss of oil film properties, and then the loss of a bearing and possibly more.

Proper selection of the lube oil system components and their arrangement within the piping and instrumentation diagrams (P & ID) are dependent upon, but not necessarily limited to, the following external and operational factors.

External Factors

- Ambient temperature range
- Tropical area
- Electrical area
- Seaside or platform location
- Local codes (CSA/CRN, IEC, country codes)

Operational Factors

- Lube oil supply pressure higher than cooling water
- Vertical process pump with dual AC motor driven lube oil pumps
- Equipment coastdown time
- Synthetic versus mineral base lube oil systems

ABSTRACT

Lube oil systems are utilized in rotating process equipment to lubricate and cool hydrodynamic bearings. These systems are essential to the life and maintenance free operation of the process equipment. Dependable performance results in up time for equipment that increases profits for the process end user.

API 610, EIGHTH EDITION LUBE OIL SYSTEM SCHEMATIC

A prerequisite for the design of proper lube oil systems and component selections is the basic understanding of the function and material requirements of the lube oil system components.

API 610, Eighth Edition (1995), base orientation requires the main lube oil pump to be shaft driven off the process pump. A single auxiliary lube oil pump is electric motor driven. Balance of system includes reservoir, single shell and tube cooler, and duplex filter. Each pump is equipped with its own relief and check valves. Instrumentation includes three pressure switches, one pressure differential indicator, two pressure gauges, two thermometers, and a sight glass on the reservoir (Figure 1, API 610 D6).

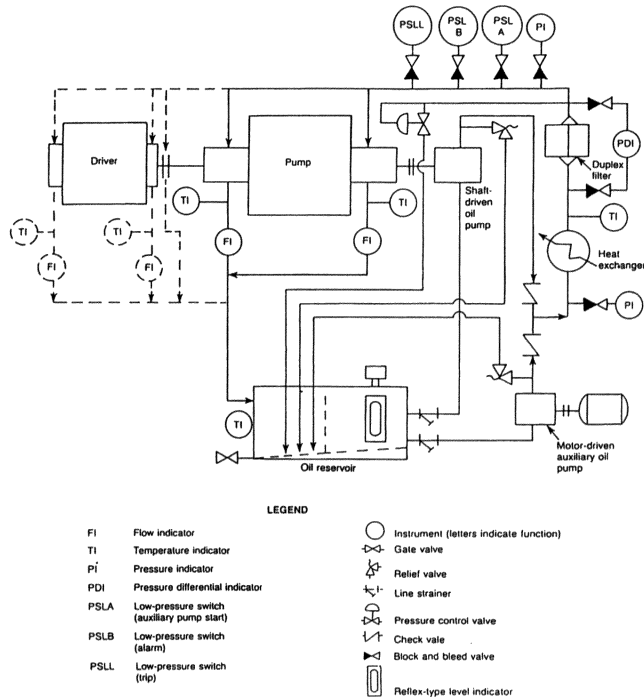

Note: This illustration is a typical schematic and does not constitute any specific design, nor does it include all details (for example, vents and drains).

Figure 1. API 610, Eighth Edition, Lube Oil System Schematic. (Used with permission of API)

TYPICAL OIL LUBRICATION SYSTEM

Components, their purpose, API 610 requirements, details of application, and maintenance considerations are evaluated below.

Lube Oil System Reservoir

Purpose—The oil reservoir has these basic purposes:

- Dissipate or settle contaminants
 - **Air**—Air is dissipated via proper baffling and adequate residence time.
 - **Particulate**—Particulate matter is allowed to settle in the low end of the reservoir. Residence time and flowrates in the reservoir determine particulate disposition in the reservoir.
 - **Water**—Water is heavier than oil. The low end of the reservoir must be designed for water drainage.
- Store a prescribed amount of oil and provide for rundown capacities.
- Provide for temperature fluctuations, expansion volumes, location for heating, and oil purifier connections.

API 610, Eighth Edition, and other good design requirements are:

- **Materials**—Austenitic stainless steel
- **Retention**—Three minutes retention time is defined as the total capacity below the minimum operating level of the reservoir. Normal system flowrate $\times 3 =$ retention capacity.
- **Armored sight glass**—Internal chamber is the same material as the reservoir. The sight glass should extend from one inch above centerline of oil return, to one inch below minimum operating level.
- **Baffle**—The function of the baffle is to separate pump suction from oil returns. Oil returns include return from process pumps and auxiliaries, lube oil pump relief valves, returns from pressure control valves, filter vents, control valve head, and instrument vents. Baffles should have an air passage at the tank top equal to three times the area of the auxiliary and main pump suction lines combined. A baffled passage is strategically located two inches above the tank bottom. This baffle should have the greatest possible distance between the main pump inlet and return line to allow oil to pass from the return side to the suction side of the reservoir. The oil travel path shall be as long as possible from the time it returns to the reservoir until it reaches the pump suction to provide the maximum amount of time for settling of contaminants (Figure 2).

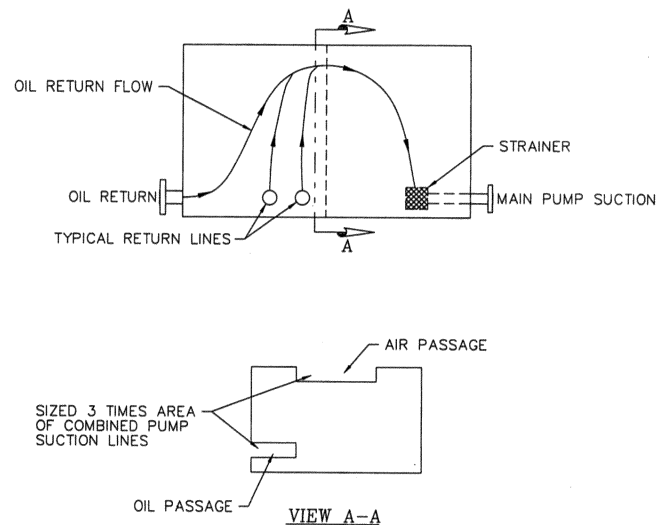

Figure 2. Reservoir Baffle Orientation and Design.

• **Sloping bottom**—Reservoir bottom should slope a minimum of 1/4 inch per foot away from the pump suction. Low end of reservoir should be equipped with a drain.

• **Reservoir fill cap**—Filler breather cap should be located on a riser to prevent water from running into reservoir. Fill cap should have a 40 micron breathing element and a 60 mesh strainer to prevent foreign airborne particles and objects found in new drum oil from being ingested into the system.

• **Mounting pads**—Mounting pads should be used for any attachments to the reservoir. Side mounted devices require a pad to prevent the foot of the device from piercing the reservoir skin. This is especially important during transportation. Top mounted devices should be bolted to pads. Holes for top mounting components should not penetrate the top of the reservoir to prevent water ingress into the reservoir.

• **Manway**—A gasketed manway and riser should be supplied so access is available to all compartments of the reservoir.

• **Return line**—Return lines should terminate below the oil level to prevent foaming. Return lines should be equipped with end

baffles, diffusers, or angle cut at 45 degrees. Return lines should discharge away from the pump suction and the reservoir bottom.

• **Pump suction lines**—Pump suction lines should be straight pipe with a minimum number of elbows to avoid accumulation of air and result in smooth pump transfers. Avoid using elbows in the suction lines to prevent air pockets and minimize the potential for cavitation.

Reservoir Sizing

Factors involved in reservoir size and selection are:

- System flowrate.
- Retention time.
- Height of return line from process equipment.
- Required working capacity.
- Rundown capacity.
- Location of auxiliary pump (internal or external of reservoir).

Refer to Figure 2 for baffle design and location. Figure 3 shows suction and return locations in the reservoir as well as reservoir capacities.

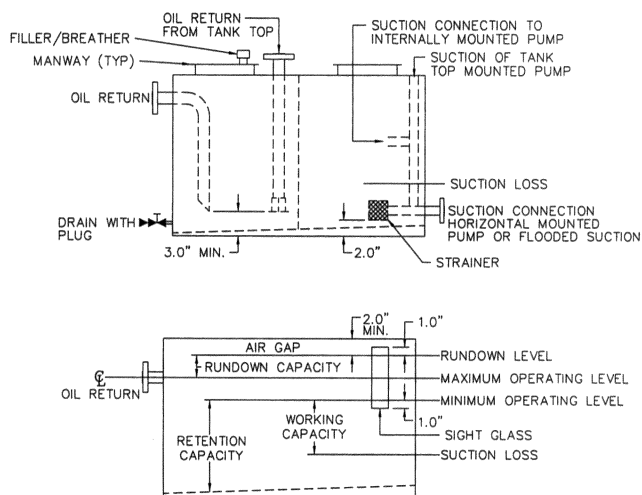

Figure 3. Reservoir Suction and Return Line Orientation/Reservoir Capacities.

Assume a total lube oil flowrate of 20 gpm. We are lubricating the process pump, a gear, and a turbine driver. $20 \times 3 = 60 =$ retention capacity (total capacity below alarm level).

• **Working capacity**—is the capacity between minimum operating level and suction loss level.

• **Rundown capacity**—is the amount of oil expected to return to the reservoir when the system is shut down. (If this is unknown, use 10 percent of the total capacity of the reservoir, refer to Figure 3 for details.)

Lube Oil Pumps

The purpose of the main shaft driven lube oil pump is to provide a flowrate to the process pump and other equipment in the drive train any time the process pump is operating. The purpose of the auxiliary lube oil pump is to provide a lube oil flowrate to process pump bearings and other equipment in the drive train prior to startup of the process equipment and any time the lube oil supply pressure drops below the specified minimum.

Many styles of pumps are available for lube oil system applications. The API community has favored two types: gear and screw pumps.

- Both pumps are positive displacement.
- The gear pump is most viable for applications:
 - At 1200 rpm to 1800 rpm input shaft speeds.
 - With oil viscosity ranges 100 SSU to 500 SSU.
 - Where lube oil pump discharge pressures are greater than 150 psi.
- The screw pumps are most viable for applications:
 - With low noise requirements.
 - Where steel cast pump casings are required.
 - Where pump input speed exceeds 1500 rpm.
 - Where high viscosity fluids are predominant.
 - Where pump discharge pressure is 150 psi or less. (Note screw pumps are available for higher pressure applications; however, gear pumps tend to be more economical and more efficient in higher pressure applications.)

Pump Sizing

The pump manufacturer as prime vendor must determine total flowrates, heat loads for the entire process pump train including the driver and gear, and specify this requirement to the lube oil system supplier.

Assuming the train requires 15 gpm, the actual minimum required pump flow is calculated as 15 gpm divided by .85 = 17.64 gpm. Used as the minimum acceptable value, .85 is added to maintain head in the lube oil supply header.

A minimum 1.5 gpm extra must be available on systems in the 5 gpm to 12 gpm range for proper valve sizing and maintaining head.

The pressure control valve is sized along with the pump and it should be sized so that the excess flow of 2.64 gpm will pass over the pressure control valve when it is between 15 percent and 20 percent open. The extra oil capacity passes over the pressure control valve back to the reservoir.

It is most important to size the main pump and auxiliary pump displacements as close to identical as possible. In any event, major deviations in flow between the two pumps will result in a change in pressure when the auxiliary pump runs alone, as compared with when the main pumps online alone. Further, consideration must be given to the pressure control valve sizing so that the valve is only 80 percent open when the excess flow of the auxiliary pump and the full flow of the main pump pass over the pressure control valve. This situation occurs whenever both pumps operate simultaneously.

Material Requirements

API 610 requires the pump housing material be cast steel when the pump is located outside the reservoir. Pumps located inside the reservoir can be of any suitable material.

Installation

API 610 does not address the issue of spacer couplings for the auxiliary pump. Therefore auxiliary pump seals typically cannot be changed during operation of the main pump, unless the auxiliary pump is removed from its sole plate.

Pumps that are mounted vertically in the tank should be mounted so the coupling is above the tank top (Figure 4). Mounting of the coupling below the tank top can result in aeration of the oil due to aerodynamic effects of the coupling.

• Pump motor bell housing is available line bored to .002 TIR. This tolerance eliminates the need for field alignments at the time of initial startup or when replacing a pump. Shimming is not required.

• We recommend the pump installation be vertical on a bell housing with C face motor, per Figure 4. The bell housing ensures a permanent alignment. The vertical pump reduces skid size

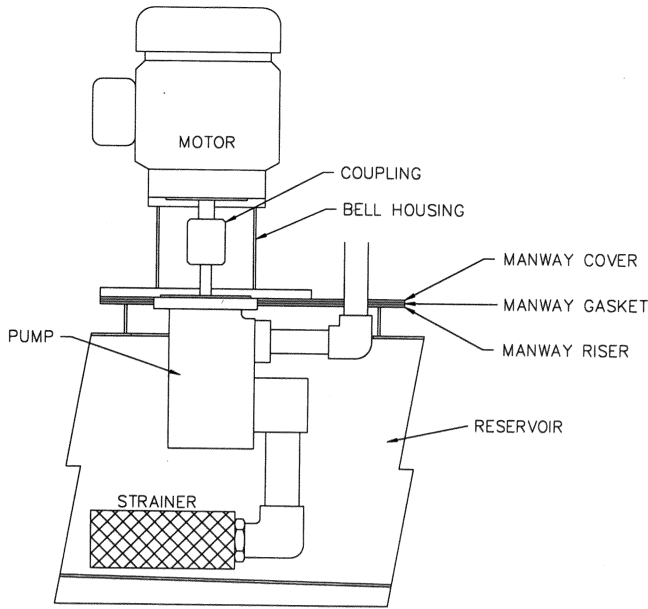

Figure 4. Vertical Pump Mounting Assembly.

(real estate is valuable) and the installation is far cleaner and the most economical.

Horizontal pump installation can be made either as foot mounts or as C face bell housing mounts.

- Foot mounting requires shims, sole plates, and field alignments.
- Horizontal pump applications typically include a Y strainer mounted externally of the reservoir in the pump suction line.

Maintenance Considerations

- Horizontal pump mounts
 - When equipped with proper sole plate and a spacer coupling, a field seal change can be made on larger screw pumps. Not all screw pump designs and sizes can have their seal changed from the shaft end.
 - Permanently installed Y strainers are located externally of the reservoir to allow for easy cleaning of the screen. This application requires additional components such as a suction isolation valve for the pump (Figure 5). The strainer typically is 100 mesh, which is intended to keep only coarse particles out of the pump. Our opinion is, if this strainer ever becomes clogged, it is time to enter the tank and clean it thoroughly. Therefore vertical pump mounts with internal strainers make the most economical design, as the extra pump suction isolation valve is eliminated.

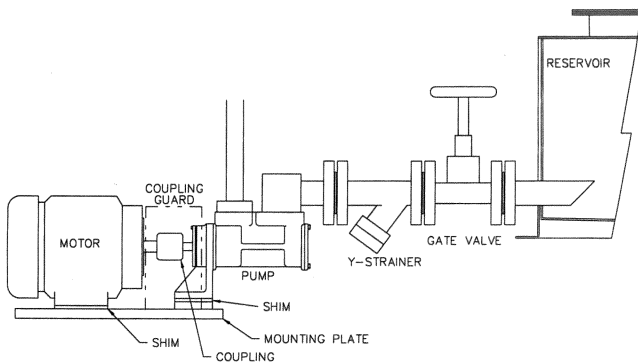

Figure 5. Horizontal Pump Mounting Assembly.

- Vertically mounted pumps (with pumps installed inside the reservoir) require the tank be opened only if a pump maintenance or replacement is necessary. Opening the reservoir presents an opportunity for contamination to enter the tank.

- Due to improved auxiliary pump suction conditions and the pump's proximity to the reservoir heater, a vertically mounted pump will be available sooner for cold starting than a horizontally mounted pump.

- We recommend a foot valve installed on the suction side of any pump that does not have a flooded suction condition.

Driver Sizing and Affects of Viscosity/Design Impacts

Total pump discharge is calculated as nominal output flowrate required by the equipment, divided by .85.

The test case is 15 gpm nominal flow and, therefore, the pump will produce 17.64 gpm minimum. Main pump speed is 3000 rpm, since this application is 50 Hz, so the electric motor driven pump must run at 3000 rpm (Tables 1 and 2).

Table 1. Screw Pump Discharge Capacity and Input Power Chart.

Speed: 3000 rpm
Flowrate - gpm

Viscosity	Pressure - PSI					
	SSU	25	50	75	100	125
33	16.7	15.6	14.7	14.0	13.3	12.8
65	17.5	16.7	16.0	15.5	15.1	14.7
100	17.8	17.2	16.7	16.3	15.9	15.6
150	18.1	17.6	17.2	16.9	16.6	16.3
650	18.8	18.5	18.3	18.2	18.0	17.9
1000	18.9	18.7	18.5	18.4	18.3	18.2
5000	19.2	19.1	19.0	19.0	18.9	18.9
10000	19.2	19.2	19.1	19.1	19.0	19.0

BHP - hp

Viscosity	Pressure - PSI					
	SSU	25	50	75	100	125
33	.6	.9	1.1	1.4	1.7	2.0
65	.6	.9	1.1	1.4	1.7	2.0
100	.6	.9	1.1	1.4	1.7	2.0
150	.6	.9	1.1	1.4	1.7	2.0
650	1.0	1.3	1.6	1.9	2.1	2.4
1000	1.2	1.5	1.8	2.1	2.4	2.7
5000	2.9	3.2	3.4	3.7	4.0	4.3
10000	4.3	4.5	4.8	5.1	5.4	5.7

Table 2. Screw Pump Discharge Capacity and Input Power Chart.

Speed: 3000 rpm
Flowrate - gpm

Viscosity	Pressure - PSI						
	SSU	25	50	75	100	125	150
33	22.6	21.2	20.2	19.3	18.6	17.9	
65	23.5	22.5	21.8	21.2	20.6	20.1	
100	23.9	23.2	22.6	22.1	21.6	21.2	
150	24.3	23.6	23.2	22.8	22.4	22.1	
650	25.1	24.8	24.5	24.3	24.2	24.0	
1000	25.2	25.0	24.8	24.6	24.5	24.4	
5000	25.5	25.4	25.3	25.3	25.2	25.2	
10000	25.6	25.5	25.2	25.4	25.4	25.3	

BHP - hp

Viscosity	Pressure - PSI						
	SSU	25	50	75	100	125	150
33	.9	1.3	1.7	2.0	2.4	2.8	
65	.9	1.3	1.7	2.0	2.4	2.8	
100	.9	1.3	1.7	2.0	2.4	2.8	
150	.9	1.3	1.7	2.0	2.4	2.8	
650	1.7	2.1	2.4	2.8	3.2	3.6	
1000	2.1	2.5	2.8	3.2	3.6	4.0	
5000	5.0	5.4	5.7	6.1	6.5	6.9	
10000	7.4	7.8	8.2	8.6	8.9	9.3	

Table 1 shows this pump is only acceptable at discharge pressures at or below 50 psi. Further, oil viscosity must be at least 150 SSU to expect a pump discharge above the required minimum flowrate.

Applications in the process pump industry generally use ISO VG 32 or VG 46 oil. The pump draws its oil supply from the reservoir, which is upstream of the heat exchanger, so this is hot oil, oil that has just rinsed heat out of the pump bearings and into the tank. At this point oil temperatures can approach 160°F and oil viscosity of approximately 70 SSU to 90 SSU. Therefore in the example, pump 3E-118 is too small for this application (Table 1).

Table 2—A 3E143J pump will produce the proper flowrate at low viscosities. Many applications require the lube oil pressure to be higher than the cooling water pressure (to prevent water leakage into the oil from a leaky tube). Typically this pump discharge pressure is around 100 psi. At 100 psi and 100 SSU, this pump produces 22.1 gpm and requires a brake horsepower of 2.0 to drive it. If we have a cold start condition, the brake horsepower becomes 3.2 hp when the oil viscosity is 1000 SSU. Oil temperature of 45°F relates to 1000 SSU. The customer needs to specify if a cold

startup is required and, if so, either a heater should be installed, or the pump driver and coupling sized for maximum load. Higher pressures also affect the selections of the relief valves, pressure control valves, etc.

Filters

Requirements API 610, Eighth Edition

- *Type*—Duplex
- *Material*
 - Housing: Cast steel
 - Elements: Cartridge materials should be corrosion resistant.
 - Filtration: 25 micron or finer
 - Other: Non bypass, stainless steel valve spool in transfer valve

Additional Suggested Requirements

Previously filters were rated by micron size. Subsequently filter ratings were changed to nominal versus absolute micron ratings. Today filter elements are rated with micron and beta ratios. In the API process pump industry, the typical duplex filter is 10 micron nominal. This means that some particles in excess of 10 microns regularly pass through the element. Today, filter manufacturers typically rate their elements at 10 micron, with a filtration ratio of 200 (beta 200). This means that one particle in 200 of a size greater than 10 microns will pass through the element.

ANSI T3.10.8.8 Standard (1994) was developed for testing and verification of effectiveness of the filter.

Many OEMs have determined that there is a direct relationship between the quality (level) of filtration on the lube oil system, and the life of the process pump and auxiliary equipment bearings. The higher the quality of filtration, the longer the service life. ISO 4406 (1987) and National Aerospace Standards (NAS) 1638 (1992) define cleanliness of critical rotating machinery (Table 3). The process pump is critical to the reliability of the process and therefore oil clarity should be NAS 1638 Class 5. API 614 (1992) cleanliness standard which has been adopted by API 610, Eighth Edition, allows for a defined number of particles to be caught at the screen of 250 microns maximum. Note this relates to a NAS 1638 Class 11. The typical quality 10 micron beta 75 element will produce NAS 1638 Class 5 results. It is recommended that lube oil systems be flushed at the point of manufacture to NAS 1638 Class 5 or finer with oil at 160°F, for a one hour duration. During testing, the oil system is mechanically agitated. Have the manufacturer provide a test report from a certified particle counting device as evidence of clarity.

Table 3. NAS 1638 Class Contamination Limits Table.

Size Range µm	Classes (Based on Maximum Contamination Limits, Particles per 100 mL)													
	00	0	1	2	3	4	5	6	7	8	9	10	11	12
5 - 15	125	250	500	1000	2000	4000	8000	16,000	32,000	64,000	128,000	256,000	512,000	1,024,000
15 - 25	22	44	89	178	356	712	1425	2850	5700	11,400	22,800	45,600	91,000	182,400
25 - 50	4	8	16	32	63	126	253	506	1012	2025	4050	8100	16,200	32,400
50 - 100	1	2	3	6	11	22	45	90	180	360	720	1440	2880	5760
over 100	0	0	1	1	2	4	8	16	32	64	128	256	512	1024

Filters should be sized so that a clean element passes the entire pump discharge flowrate at maximum 5 psi pressure drop across the elements, filter housing, and transfer valve at design conditions. Therefore (for the test case), we should design the filter to pass the entire flowrate at viscosities between 70 SSU and 650 SSU, if minimum ambient is 50°F and unit is not equipped with a heater.

Given that API 610 requires the non bypass filter, and only a pressure differential indicator is provided to visually determine filter condition, specific considerations should be made in the filter selection process.

- Collapse pressure of the element should exceed the pump's relief settings. If the element gets very dirty, oil will pass over the pump relief and the lube oil supply pressure will decrease until oil pressure at the header drops, causing an alarm condition. This alerts the operator to look at filter condition and transfer to the clean element. A bypass design or a low collapse pressure element will allow dirt to flow into the bearing when the element clogs and the bypass works or the element fails. Bypass design elements are equipped with a relief valve poppet. Any time the differential across the element exceeds the bypass valve setting, the bypass opens and allows unfiltered oil downstream.

A better solution is the addition of a pressure differential switch across the filter housing to alarm at a dirty filter condition. Presetting the alarm at 25 psid to 30 psid will give the operator plenty of time to schedule the element change. A filter element that is properly sized will be contaminated/clogged 60 percent to 70 percent of its capacity, at a pressure drop of 30 psid.

ASME code stamped filters should be considered based on size, pressure, volume, and geographic locations where code vessels are mandated.

Filter transfer valves should be open in the neutral position. Inlet port of the transfer valve should be open to the inlet of both elements. The outlet of the transfer valve should be open to the outlets of both elements. This will guarantee continuous flow when transferring from one filter to another.

Maintenance Considerations

The single component expected to be maintained is frequently the filter element. The old saying "cleanliness is next to godliness" certainly applies here. Replacing the element regularly increases bearing life.

1. Consideration should be given to locating the filter at the outside edge of the skid for ease of maintenance.

2. Equip the filter with individual canister vents and drain valves. The filter and all maintenance valves shall be located in an accessible location on the skid.

3. Supply a balance/prefill line and appropriately sized orifice, for ease of filter maintenance.

4. Above items 2 and 3 allow the serviced element to be prefiltered and vented of air prior to placing it in service. The orifice is used to restrict flow into the serviced element canister to prevent an unwanted loss of system pressure. The orifice also is used to balance the pressure on both sides of the transfer valve to facilitate a valve shift. Drain valves allow the operator to drain hot oil from canisters prior to removing it from the system. The operator can also verify that the leakage rate of the transfer valve is acceptable prior to opening the housing. Excessive leakage in the transfer valve will cause a system shut down. Drain valves are useful for oil sampling, particle counting, and prevention of oil spills. Refer to Figure 6 for filter vent, drain, and balance line details.

Figures 7 and 8 show two types of duplexing of heat exchangers and filters.

Heat Exchangers

API 610, Eighth Edition, requirements for heat exchangers are:

- *Type*—Shell and tube
- *Material*—Tubes inhibited admiralty (fresh water service), shell steel (pressure retaining)
- *Orientation*—Cooling water is on the tube side.

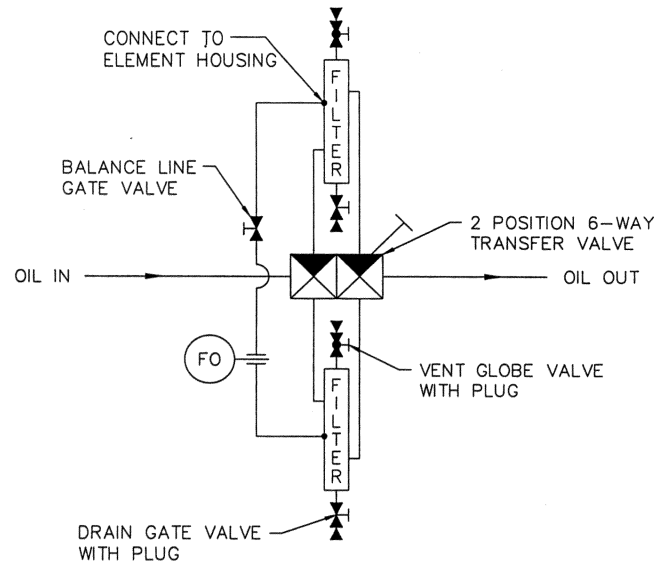
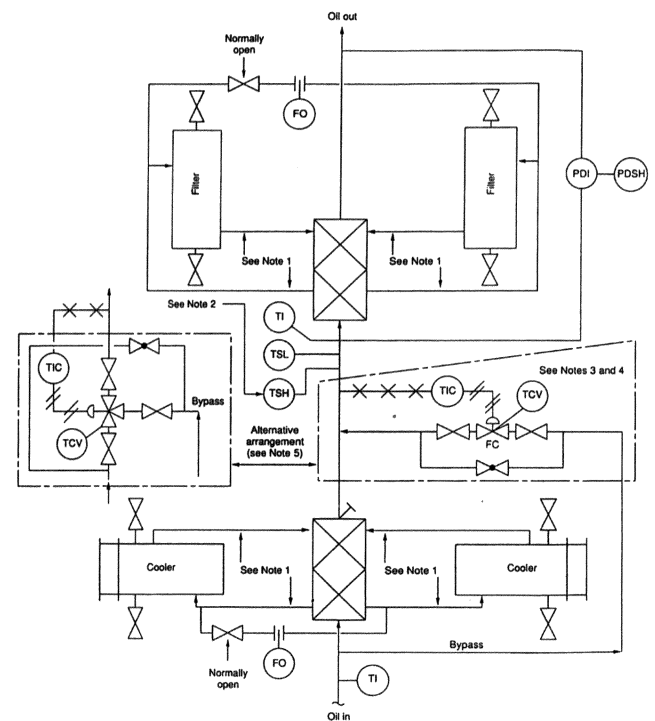

Figure 6. Duplex Filter with Transfer Valve.



- Notes:
1. Option A-17a: The purchaser may specify tight shutoff requiring spectacle blinds.
 2. Option A-17b: The purchaser may specify a high-temperature switch (TSH) and/or a low-temperature switch (TSL).
 3. Option A-17c: The purchaser may specify a bypass oil line and a constant-temperature control valve.
 4. Option A-17d: If the fail-closed (FC) feature of the direct-acting temperature control valve is not acceptable, the purchaser may specify a valve with a fail-locked (FL) feature.
 5. Option A-17e: The purchaser may specify a constant-temperature three-way control valve as an alternative.

Figure 7. Twin Oil Coolers and Filters with Separate Continuous Flow Transfer Valves. (Used with permission of API)

Other Design Considerations

- *Velocity in tubes*—5 ft/sec minimum, 8 ft/sec maximum

Fouling factor tubes: .002 hr • ft² • °F/Btu

Fouling factor shell: .002 hr • ft² • °F/Btu

Maximum oil temperature out of cooler: 120°F

Water temperature rise: 20°F

Maximum pressure drop: 5 psi

Capacity: Maximum heat load of pump, gear, and driver, plus add the horsepower of the lube oil pump driver. The entire lube oil system input horsepower goes to heat.

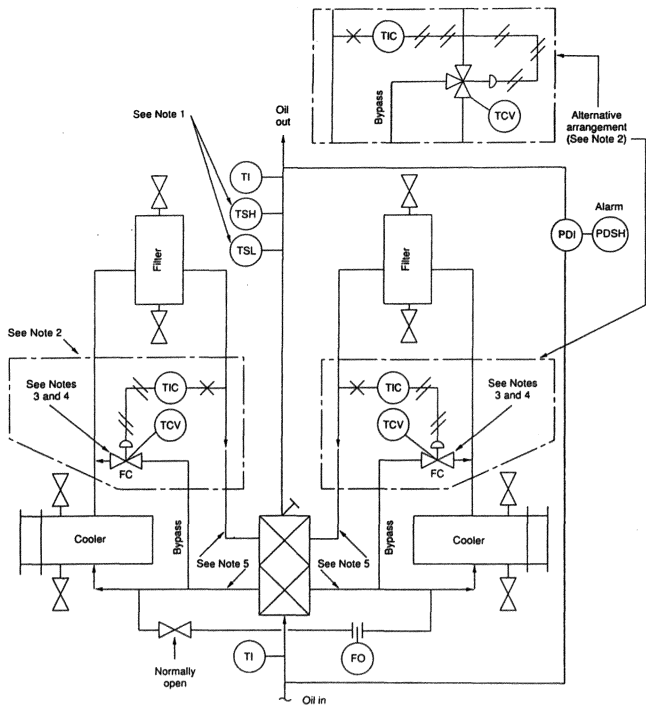

Notes:
 1. Option A-18a: The purchaser may specify a high-temperature switch (TSH) and/or a low-temperature switch (TSL).
 2. Option A-18b: The purchaser may specify a constant-temperature three-way control valve as an alternative.
 3. Option A-18c: The purchaser may specify a bypass oil line and a constant-temperature two-way control valve.
 4. Option A-18d: If the fail-closed (FC) feature of the direct-acting temperature control valve is not acceptable, the purchaser may specify a valve with a fail-locked (FL) feature.
 5. Option A-18e: The purchaser may specify tight shutoff requiring spectacle blinds.

Figure 8. Twin Oil Coolers and Filters with a Single Continuous Flow Transfer Valve. (Used with permission of API)

(Special note: It typically is not possible to obtain 20°F cooling water rise and 5 ft/sec velocity on cooling water through the tubes simultaneously on lube oil coolers. Most applications result in a selection compromised at 2.75 ft/sec to 3.25 ft/sec velocity and 8°F to 10°F temperature rise.)

Maintenance Considerations

- Removable bundles add ability to change bundle without removing shell.
- Consider adding vent and drain valves in other locations to facilitate maintenance.
- Duplex heat exchanger arrangements are necessary on unsparred equipment. In the case of duplexed heat exchangers, a balance valve, vents and drain valves on the shell, and vent and drain valves on the cooling water chamber should be added to facilitate changing heat exchangers during operation.

Relief Valves

API 610, Eighth Edition, requirements are:

- Valve shall have a carbon steel body with stainless steel trim.
- Valves shall be located downstream of each pump discharge (refer to Figure 1 for location).

Two Types of Valves are typically used:

- **Direct acting type**—Fulflo valves are direct acting. A spring retains a piston in a bore. Oil working against the piston overcomes the spring and pushes the piston back, allowing oil to pass to the tank port. As flowrate increases, the pressure at the inlet increases, i.e., pressure drop across valve increases.
- **Pilot operated type**—Crosby, Consolidated, AGCO, etc., manufacture a pilot operated valve. Oil works against the area of a small control poppet. When oil pressure overcomes the spring, oil

passes to the tank. This allows a pressure drop to occur at the main/slave spool, which backs off. One advantage of the pilot operated valves is that within the suggested flow range of the valve, an increase in flow does not have an effect on the set pressure.

Other Design Considerations

- Relief valve oil return lines should always terminate below the oil level in the reservoir.
- Do not install isolation valves either immediately upstream or downstream of the relief valve, unless your company follows a lockout policy or you specify car seal open valves.
- Conduct site tests to verify valves do not leak.

Pressure Control Valves

API 610, Eighth Edition, requirements are:

- **Material**—Cast steel bodies with stainless steel trim
- **Location**—Downstream of filter and immediately upstream of lube oil supply connection
- **Size**—Must handle the excess flow of the auxiliary pump and the entire flowrate of the main pump simultaneously at an 80 percent open condition

Other Design Considerations

- **Flowrate**—The pressure control valve must be sized so that it passes excessive main lube oil pump flow when the valve is 15 percent to 20 percent open. The valve must also pass the entire flowrate of the auxiliary lube oil pump and the excess flow of the main lube oil pump at an 80 percent open condition. The situation occurs any time both pumps are operated simultaneously.
- System designers are required to determine if an integral or external pilot is required. Valves at one inch port size and below, work well with integral pilots. Valves 1-1/2 inch and above typically are far more responsive with external pilots. The reaction time of the valve must be fast enough to maintain a pressure between set point and 10 percent accumulation. Some externally piloted valves will reduce system pressure by over stroking when the second pump starts.
- **External oil pilots versus pneumatic pilots**—The key factor to be considered is time of actuation. In small API 610 packages, response time is acceptable when using oil pilots. Oil pilots are less expensive and are easily maintained.

Maintenance Considerations

If continuous duty is required or the process pump is unsparred, the design should include isolation bypass and drain valves, as shown in Figure 9. Note that for reducing valves, two isolation valves are required.

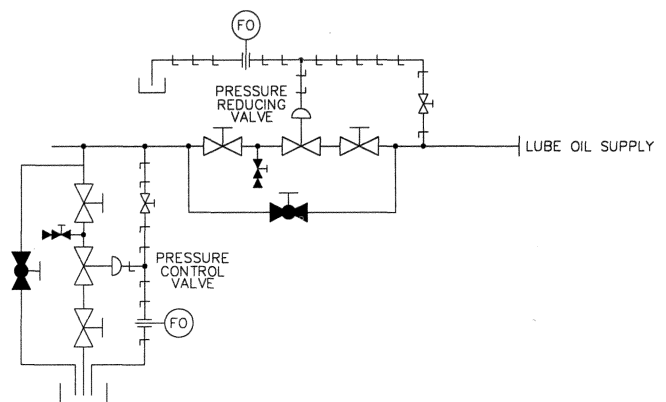

Figure 9. Pressure Control and Pressure Reducing Valves with Isolation and Bypass Valves.

Instrument Isolation Valves/Root Valve

API 610, Eighth Edition, requirements are:

- **Type**—Block and bleed valves, valves can be combination style
- **Materials**—Carbon steel bodies with stainless steel trim
- **Size**—1/2 inch NPT minimum
- **Connection**—Each pressure instrument must have its own pressure tap.

Other Design Considerations

- Install a test port as shown in Figure 10 (b), so the instrument can be checked and calibrated during operation.
- Do not install an isolation valve on PSL switch. If isolated, the process pump will be unprotected from alarms due to loss of lube oil pressure.

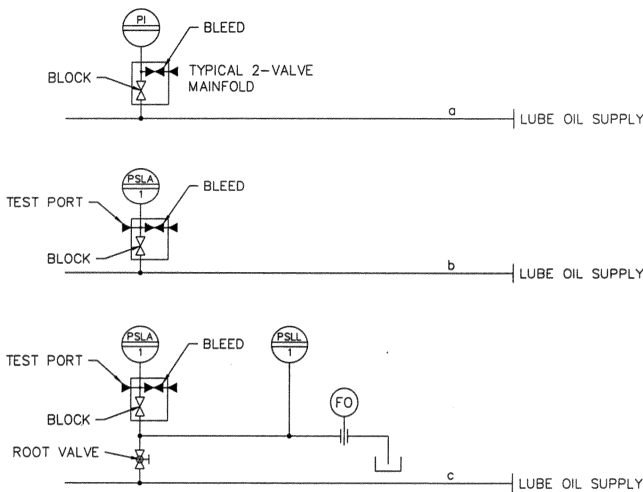

Figure 10. Instrument Valving.

Maintenance Considerations

- Always install a union at the electrical connection of the instrument, so it can be removed without cutting the conduit.
- Always install a pipe union or tube union between the isolation valve and the instrument, so the switch can be removed without having to shut the system down.
- Consider the use of stainless steel for gauge boards; less galvanic action occurs.

Lube Oil Piping

API 610, Eighth Edition, requirements are:

- Type of piping connections and fittings
 - Socketweld flanged connection upstream of filter
 - Butt weld flanged connection downstream of filter
- Flanges
 - 150# RF, socketweld or slip on upstream of filter
 - 150# RF, slip on or butt weld downstream of filter
- Bolts and studs—ANSI-A193-B7 studs or hex head bolts, and ANSI-A194-2H nuts
 - Bending is preferred over welded joints.
 - Other requirements—ANSI B31.3 Piping Code with five percent radiography for butt welds
 - Materials—316L pipe schedule is per Table 4

Table 4. Requirements for Piping Materials. (Used with permission of API)

System	Auxiliary Process Fluid		Steam		Cooling Water		Lubricating Oil
	Nonflammable/Nonhazardous	Flammable/Hazardous	≤ 500kPa (≤ 75 psig)	> 500kPa (> 75 psig)	Standard	Optional	≤ 1 NPS
Pipe	Seamless ^a	Seamless ^a	Seamless ^a	Seamless ^a	—	ASTM A33 Type F Schedule 40 galvanized to ASTM A153	—
Tubing	ASTM A269 seamless Type 316 stainless steel ^b	ASTM A269 seamless Type 316 stainless steel ^b	ASTM A269 seamless Type 316 stainless steel ^b	ASTM A269 seamless Type 316 stainless steel ^b	ASTM A269 seamless Type 316 stainless steel ^b	—	ASTM A269 seamless Type 316 stainless steel ^b
All valves	Class 800	Class 800	Class 800	Class 800	Class 200 bronze	—	Carbon steel Class 800
Gate and globe valve	Bolted bonnet and gland	Bolted bonnet and gland	Bolted bonnet and gland	Bolted bonnet and gland	—	—	Bolted bonnet and gland
Pipe fittings and valves	Forged Class 3000	Forged Class 3000	Forged Class 3000	Forged Class 3000	ASTM A338 and A197 Class 150 multistage iron galvanized to ASTM A153	—	Type 316L Stainless steel
Tube fittings	Manufacturer's standard	Manufacturer's standard	Manufacturer's standard	Manufacturer's standard	Manufacturer's standard	—	Manufacturer's standard
Fabricated joints ≤ 1 NPS	Threaded	Socket-welded	Threaded	Socket-welded	Threaded	—	Threaded
Fabricated joints ≥ 1.5 NPS	—	—	—	—	—	Purchaser to specify	—
Gaskets	—	Type 316 stainless steel spiral-wound	—	Type 316 stainless steel spiral-wound	—	—	Type 316 stainless steel spiral-wound
Flange bolting	—	ASTM A193 Grade B7 ASTM A194 Grade 2H	—	ASTM A193 Grade B7 ASTM A194 Grade 2H	—	—	ASTM A193 Grade B7 ASTM A194 Grade 2H

Note: Carbon steel piping shall conform to ASTM A106, Grade B; ASTM A524; or API Specification 5L, Grade A or B. Carbon steel fittings, valves, and flanged components shall conform to ASTM A105 and A181. Stainless steel piping shall conform to ASTM A312, Type 316L, Class A for corresponding international materials.
^a Schedule 80 for diameters from 1/2 NPS to 1 1/2 NPS, Schedule 40 for diameters 2 NPS and larger.
^b Schedule 40 for a diameter of 1 1/2 NPS, Schedule 10 for diameters of 2 NPS and larger.
^c Acceptable piping sizes are as follows (refer to ISO 4200): 15.7 mm diameter × 1.60 mm wall (1/2 in. diameter × 0.065 in. wall) 19 mm diameter × 2.6 mm wall (3/4 in. diameter × 0.095 in. wall) 23 mm diameter × 2.9 mm wall (1 in. diameter × 0.109 in. wall).
^d Carbon steel slip-on flanges are permitted.

- Flush per API 614
- Hydro per API 614
- Long shank plugs only
- Bushings are not allowed.

Other Design and Maintenance Considerations

- Always use pipe support clamps of the same material as the piping, otherwise isolation pads and nonmetallic dampeners should be considered.
- Always install flanges so they are located immediately downstream of the valve and are in line with the valve body. This allows the flange to be tightened in 1/4 inch turn increments if a threaded valve is used.
- Provide vent and drain valves for maintenance purposes in piping.

Instruments

API 610, Eighth Edition, requirements are:

- Devices located per schematic (Figure 1)
- Pressure connections—1/2 inch NPT
- Wetted materials—316 stainless steel
- Pressure dials—4 1/2 inch dial with safety back
- Thermometers—5 inch dial with a thermowell

Design Considerations

When selecting pressure temperature switches, always verify the switch dead band. Be sure to select switches so the dead band of one switch does not overlap a set point of another switch function.

If permissive pressure switch is set at 30 psi increasing, and the alarm for low oil pressure switch is set at 25 psi decreasing, be sure the permissive switch resets on decreasing before reaching 25 psi. Failure to look at dead band, results in system instrumentation indicating both an okay pressure and low pressure signal simultaneously.

• Pump suction line sizes should be designed at 4 ft/sec maximums. Return lines should slope toward reservoirs and run half full as a maximum. Pressure lines should be designed for 10 ft/sec maximum velocities.

• Instrument sense tubing should be seamless, .065 wall 1/2 inch O.D., 316L stainless steel.

• Three inch pipe size is required as a minimum when thermowells are required in the piping.

Function of Pressure Switches During Startup, Alarm/Lube Oil Pump Transfer, and Trip of Process Pump

• Refer to Figure 1. The lube oil system includes three pressure switches. The instrument legends for these switches are PSLA, PSLB, and PSLL. The functions of these switches are as follows:

- PSLA—Low pressure switch starts auxiliary lube oil pump. Typically set at 15 psi decreasing.
- PSLB—Low pressure switch. Alarms low lube oil pressure. Typically set at 15 psi decreasing.
- PSL—Low low pressure switch. Trips process equipment. Typically set at 12 psi decreasing.
- The lube oil supply header pressure is controlled by the pressure control valve, which is typically set at 20 psi.

Typical Operating Sequence for Startup/Alarm Pump Transfer/Trip Function

• *Startup*—In the shelf or low pressure state, all switch elements are open. The customer starts the auxiliary lube oil pump and, as pressure rises above 12 psi, switch PSLL closes. Pressure continues to rise to 15 psi where switch PSLA and PSLB close. This indicates lube oil supply pressure is adequate, and from a lube oil supply standpoint it is okay to start the process pump. Pressure continues to rise to 20 psi, which is the set point for the pressure control valve. If all other process permissives have been satisfied, the customer starts the process pump. As the process pump comes up to speed, a flowrate is discharged from the main lube oil pump into the lube oil system. At this point, both the main lube oil pump and the auxiliary lube oil pump are operating simultaneously. The pressure control valve must open to pass the excess flowrate of the main pump and the total flowrate of the auxiliary pump back to the reservoir. System pressure with both pumps running may equal the original pressure control valve (PCV) set point, or may increase a maximum of 10 percent. We refer to this 10 percent increase as 10 percent accumulation. The customer verifies, via pressure gauge and pressure switch signal, the lube oil pressure is adequate and he shuts down the auxiliary lube oil pump.

• *Low pressure alarm and lube oil pump transfer*—Should lube oil pressure drop to 15 psi, PSLA switch contact opens and the auxiliary lube oil pump starts. PSLB switch contact opens simultaneously at 15 psi decreasing and sounds the low lube oil pressure alarm. Normally the addition of the auxiliary lube oil pump flow to the circuit raises the lube oil supply pressure. Pressure switches PSLA and PSLB will close. At this point, the electrical control circuit should not shut down the auxiliary lube oil pump, as pressure will again drop off to the low pressure alarm setting. The operator should be forced to acknowledge the low lube oil pressure alarm and determine the root cause for it. If the operator cannot determine the cause, the auxiliary lube oil pump is left operating until the spare process pump can be started. Items as simple as a dirty filter can result in a low supply header pressure.

• *Trip*—Should the lube oil supply pressure drop to 12 psi during operation, pressure switch PSLL will open. This is the trip signal for low low lube oil supply pressure and the process pump should be shut down immediately. During shutdown, the auxiliary lube oil pump continues to run.

EFFECTS OF EXTERNAL FACTORS ON LUBE SYSTEM COMPONENT SELECTIONS

External factors bear significantly in the arrangement of the schematic of the lube oil system components. The following discussion briefly analyzes the effects of these factors on schematic design and component selections.

Ambient Conditions, Low Ambient (figure low ambient schematic)

- Reservoir
 - Include reservoir heater with incoloy sheath. Watt density should not exceed 15 Watts/in². Above 15 Watts/in² density, oil will coke out. The addition of the heater should prompt the designer to install a thermostat for control and an oil level switch to shut down the heater on low oil level.
 - Heater shall be sized to bring the oil up to permissive start temperature in a low ambient condition within four hours.
 - Reservoirs may require insulation.
 - Design consideration should be given an open coil heater that is mounted in an atmospheric well within the reservoir. The heater well combination allows the heater to be replaced without having to first drain the reservoir. All heaters should be installed below the minimum operating level in the reservoir.
 - Consider the installation of an oil purifier. Low ambient conditions can result in a buildup of condensation in the reservoir and water in the oil.
 - Pump/Motor
 - Size of the electric motor is dependent upon fluid viscosity and ambient conditions with the mineral base oils. As ambients drop, viscosity increases, resulting in an increase in a higher bhp at the pump. In Table 1, one can see that at 100 psi, bhp increased from 1.4 to 3.7 with a viscosity range of 100 SSU to 5000 SSU.
 - For ambient ranges below 20°F, we recommend space heaters in the electric motors.
 - Filters
 - If low ambient startups are required, the design should include selection of filter elements that can withstand lube oil pump relief settings, plus 15 percent.
 - Heat exchangers
 - If ambient conditions are low, a temperature control valve should be installed on the oil side of the cooler. This valve should be set up as a mixing valve to facilitate a flow of warm oil through the cooler, to keep the charge of oil in the cooler warm.
 - Consideration should be given to an air to oil cooler with a mixing valve (Figure 11).
 - Pressure control valves
 - Pressure control valves can be equipped with a pilot operated actuator. A needle valve and orifice are plumbed into the circuit, per Figure 12, to maintain temperature of the oil in the actuator.
 - Instrumentation
 - Figure 10 (c) arrangement should be provided for instruments operating in low ambient conditions. We recommend frost guards for reservoir level glasses when ambients are below 15°F.
- ### *High Ambients above 120°F and/or Direct Sunlight (Figure 11, high ambient schematic including an air to oil cooler)*
- Reservoir
 - Two inches of thermal insulation is suggested.
 - Sight glass with UV protective guards
 - Sun shields over the instrument gauge board
 - Pumps/Motors
 - Be sure to verify lube oil return line temperature in the reservoir. Where oil return temperatures exceed 170°F, we recommend changing elastomers from Buna® to Viton®.

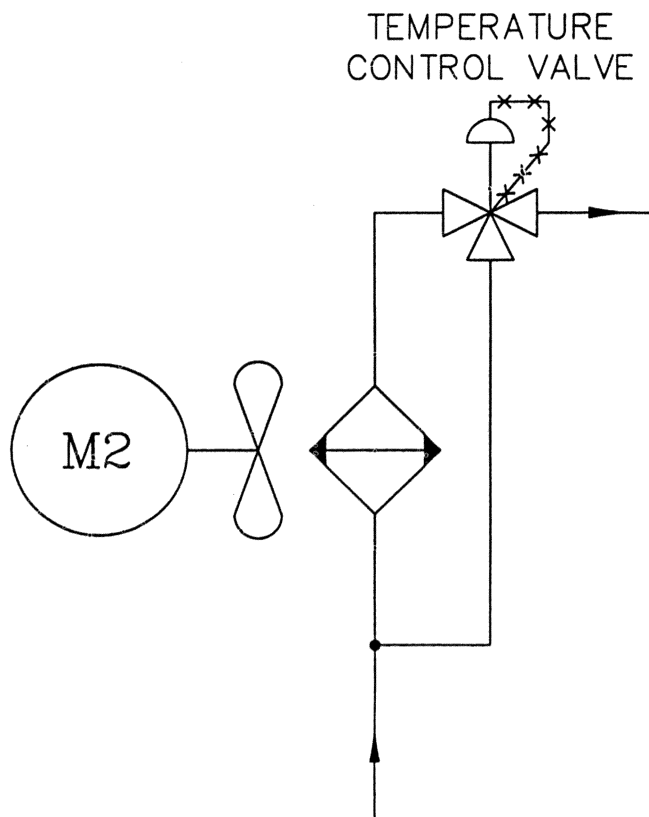

Figure 11. Air to Oil Cooler with Mixing Action Temperature Control Valve.

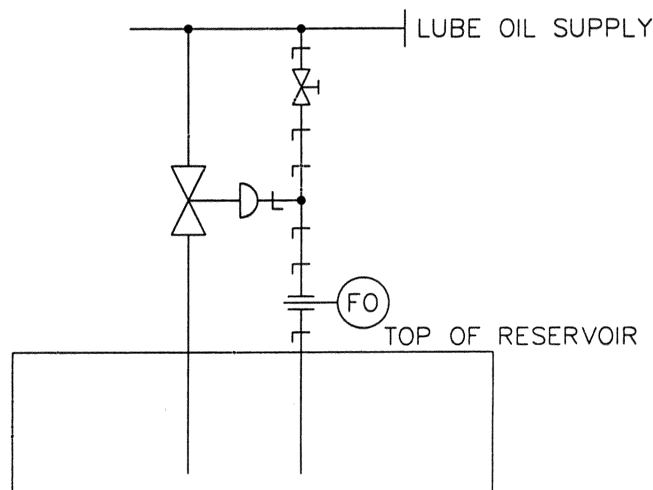

Figure 12. Pressure Control Valve with External Pilot Vented to Reservoir.

- Heat exchangers

- Solar loads and high ambient loads must be included in the total heat load from bearings, and latent heat transmitted through the shaft to the lube oil.

- When an air to oil cooler is specified, the closest ΔT between lube oil supply temperature and ambient temperature is 15°F. If the ambient is 105°F, the lowest economical oil temperature out to the bearings is 120°F. This is referred to as ΔT 15°F, the approach. As the approach temperature becomes less than 15°F, the cooler price increases exponentially.

- Instrumentation

- Figures 10 (a) or 10 (b) can be used.

- Tropical Area/Seaside or Platform Locations*

- Tropical areas

- Reservoir should be carbon steel with epoxy paint interior or stainless steel.

- Duplex filters should include stainless steel internal fasteners and polyester elements. The paper elements tend to absorb more water and this causes premature clogging.

- Use stainless steel shim stock under pumps and motors.

- Seaside or platform location

- Special coating efforts should be made for all components.
 - Galvanized skid, frame, supports, conduit, pipe flange bolting, etc.

- Stainless steel or galvanized gauge boards

- Eliminate aluminum materials typically found in pump motor couplings, pump seat retainers, and instruments.

- If sea water is used for cooling, change cooler tubes to 20/30 copper, nickel, or titanium. Where air to oil coolers are required, choose phenolic coatings.

- Electrical Area Class/CSA, CRN, IEC, Country Codes*

- Electrical area class

- Select electric motors, reservoir heaters, and instruments to meet electrical code class.

- Conduit, conduit fittings, and conduit seals should be selected to meet local codes, customer's standards, and National Electrical Code (NEC) area classifications.

- CSA/CRN, UL, FM

- Canadian electrical standards require that all electrical components require Canadian Standards Association (CSA) labels for use within their specific area class. Further, for any hazardous location wiring, it is necessary to obtain a CSA certificate. Today the provinces of Canada individually require Canadian Registration Numbers (CRN) for all vessels, pipe fittings, and some valves. Vessel manufacturers, fitting manufacturers, and system assemblers can apply to the local provincial authorities for the necessary permits and review of designs.

- UL, FM labels are not available for all the electrical component manufacturers typically used on lube oil systems. Check with the manufacturers of the lube oil system components.

- Note that many foreign governments have written their codes around other countries. Therefore, many countries will accept CE, CENELEC, CSA, or other standards certificates.

- Country codes

- Such countries as China, Malaysia, and others have their own ASME type codes or inspection programs. China has its own pressure vessel code. Malaysia requires Department of Occupational Safety and Health (DOSH) inspections. Verify with the end user or AE, which codes are required and which are acceptable alternatives.

Operational design factors significantly affect the arrangement of the schematic and the selection of the lube oil system components.

The following is a brief discussion of the affects of operational factors on the lube oil system.

Lube oil pressure higher than cooling water pressure—This option is selected any time the unacceptable condition exists where

a leaking tube in the heat exchanger will result in water entering the lube oil system. Increasing lube oil pressure at the heat exchanger reduces the possibilities of water entering the lube oil system.

When this operational requirement is placed upon the operation of the system, it is necessary to include a back pressure control valve (PCV-1) and a pressure reducing valve (PCV-2). Figure 13 is the typical schematic. The purpose of PCV-1 is to set the lube oil pressure 5 psi to 10 psi above the cooling water pressure. PCV-2 is a reducing valve that lowers the pressure to a required pressure at the inlet to the lubricated bearing orifice.

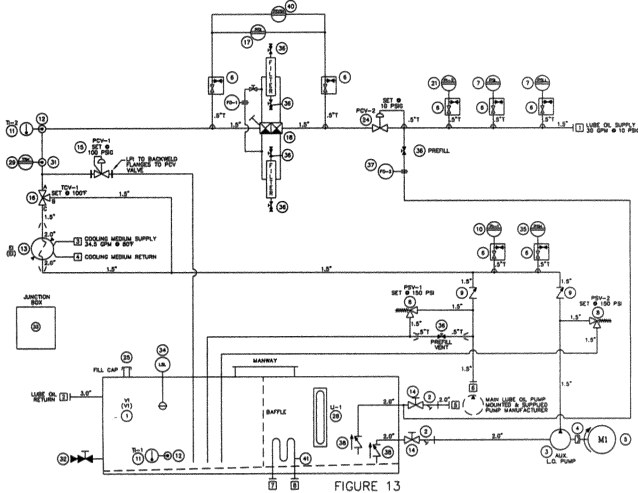

Figure 13. API 610 Schematic with Typical Options.

- Lube oil pump, motors, heat exchangers, and filters should be sized to operate at the higher pressures.
- Placing the pressure control valve downstream of the cooler allows the entire pump flow to pass through the cooler. Placing the valve upstream of the cooler reduces the flow through the cooler to only the allowable flowrate for the pump bearings.
- For normal or high ambient conditions, the back pressure control valve is placed downstream of the cooler, as this increases scrubbing action in the cooler, and reduces its size and the subsequent cooling water required.
- For low ambients, place the back pressure control valve upstream of the cooler. This minimizes oil pressure drop as only the oil flowrate required at the bearings will pass through the cooler.
- The pressure switch that signals both pumps are operating may be moved upstream of the pressure reducing valve, where we rely on the valve's pressure accumulation to make the switch and signal stopping of the auxiliary lube oil pump.

Vertical Process Pumps

Many times when the application includes a vertical process pump, it is necessary to have the main and auxiliary lube oil pumps AC motor driven. This situation occurs when the shaft of the driver is down. The distance between the bottom of the process pump and the ground is not adequate to fit in the lube oil pump.

- Select the main and auxiliary lube oil pumps in identical displacements.

Equipment Coastdown Time

Few process pumps have the requirement of extended coastdown times. In remote locations where power is not always

reliable, an additional lube oil supply with a different power source may be necessary during coastdown.

- Rundown tanks are mounted above the process pump and are sized to provide the system with lube oil flow during coastdown, as a result of power loss (Figures 14 and 15). Note that the coastdown reservoir should be equipped with an atmospheric check to allow air into the vessel on coastdown.

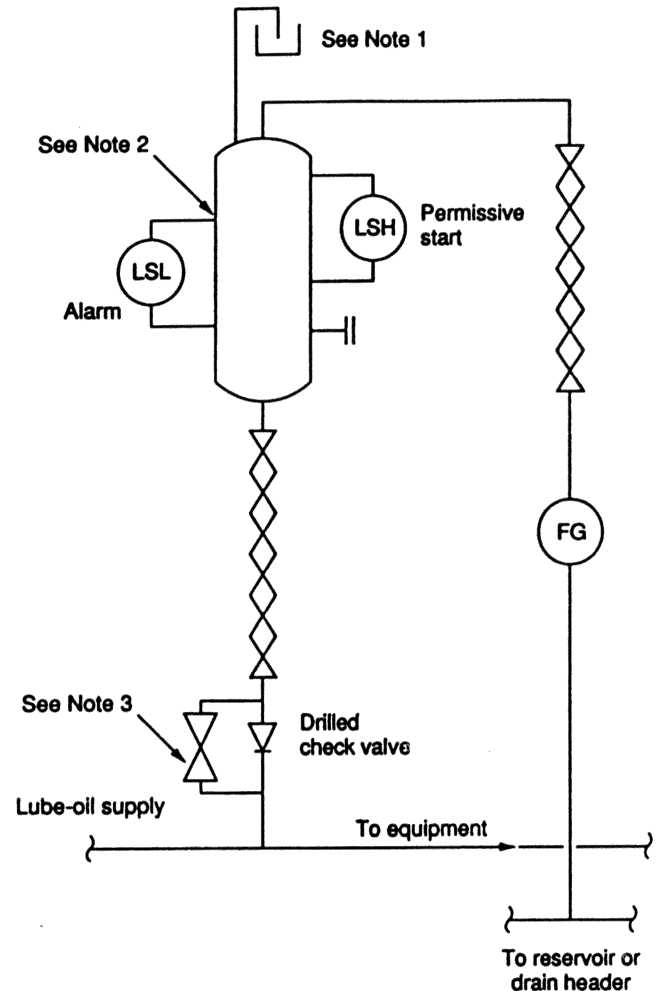

Notes:

1. Option A-13a: The purchaser may specify an atmospheric breather valve.
2. This tank shall be located at an elevation such that the static head is less than the equipment lube-oil trip pressure.
3. This valve is normally closed; it is opened only to fill the tank before the equipment is started.

Figure 14. Emergency Lube Oil Atmospheric Rundown Tank. (Used with permission of API)

- For vertical process pumps, a coastdown tank is used because the main lube oil pump is AC motor driven, not shaft driven and on loss of power, the AC motor driven pump stalls.

- A coastdown tank bypass is recommended for all applications to maintain a warm slug of oil in the coastdown tank. For low ambient, a heater and level switch or insulation are additional options.

- Remember to size the lube oil system reservoir to allow for coastdown capacity. The reservoir sight glass should be arranged such that it spans from two inches above the coastdown level to one inch below the operating level.

- Location of skid—site elevation, indoors or outdoors, ambient temperatures, environmental conditions (dust, saline atmosphere, etc.)
- Electrical area classification: class, group, and division
- API requirements/options
- Voltage/frequency/phase for motors, heaters, and instrumentation
- Cooling water type and quality including supply and return temperatures. Maximum allowed cooling water pressure drop. Maximum cooling water pressure.
- Sound level limitations, if any
- Type of piping and fitting—API 610 or others, stainless or carbon with listed material and pipe schedule, flange style/type/finish, socket or butt weld fittings
- Code stamp requirement for cooler and/or filter
- Purchasing specifications and data sheet

As a guide, complete the purchaser "General Purpose Lube Oil System Data Sheet" (Figure 16).

GENERAL PURPOSE LUBE OIL SYSTEM DATA SHEET

Rev. No.	0	1	2	3	Job No.	Page	of
Date					Client		
Originator					Location		
Reviewed					Unit		
Approved					Item No.		
					Service		
					Requisition No.		

1 Design, manufacture, inspection and testing shall conform to specification:							
2 Information to be completed by: <input type="checkbox"/> Purchaser <input type="checkbox"/> Manufacturer <input type="checkbox"/> Purchaser/Manufacturer:							
3 Manufacturer:		Model:		Serial No.:		No. Req'd:	
4 Operating and Construction Features							
5 Pumps				Reservoir:			
<input type="checkbox"/> Item No. <input type="checkbox"/> Mfr.:				<input type="checkbox"/> Electric Heater <input type="checkbox"/> Steam Heater:			
<input type="checkbox"/> Pump Type: Main: <input type="checkbox"/> Standby:				<input type="checkbox"/> Heater Mfr.:			
<input type="checkbox"/> Driver Type: Main: <input type="checkbox"/> Standby:				<input type="checkbox"/> Internal Coating: <input type="checkbox"/> Oil Purifying Conn.:			
<input type="checkbox"/> Rated Cap. (GPM):				<input type="checkbox"/> Working Cap. (gal.): <input type="checkbox"/> Retention (gal.):			
<input type="checkbox"/> Discharge Press (psig):				<input type="checkbox"/> Lubricant Type/Initial Fill (gal.): /			
<input type="checkbox"/> RV Set point (psig):							
<input type="checkbox"/> Casing Mount: <input type="checkbox"/> Horizontal <input type="checkbox"/> Vertical				Lines and Connections:			
<input type="checkbox"/> Coupling Type/Mfr.:				<input type="checkbox"/> Tubing For Instruments: <input type="checkbox"/> Min Size:			
<input type="checkbox"/> Seal Type/Mfr.:				<input type="checkbox"/> Pipe: <input type="checkbox"/> Butt Welded <input type="checkbox"/> Socket Welded <input type="checkbox"/> Threaded			
Materials of Construction:				<input type="checkbox"/> Flanged <input type="checkbox"/> Customer Conns.: On skid edge.			
<input type="checkbox"/> Pump Case: <input type="checkbox"/> Reservoir:				Instrumentation: <input type="checkbox"/> Electrical Area Class:			
<input type="checkbox"/> Filter: Housing: <input type="checkbox"/> Element:				Temperature Indicators: <input type="checkbox"/> Mfr.:			
<input type="checkbox"/> Cooler: Shell: <input type="checkbox"/> Tubes:				<input type="checkbox"/> Reservoir			
<input type="checkbox"/> Piping: Upstrm/Dnstrm Filter: /				<input type="checkbox"/> Cooler In/Out <input type="checkbox"/> Bearing Drain			
<input type="checkbox"/> Valves: Body/Trim: /				Pressure Indicators: <input type="checkbox"/> Mfr.:			
<input type="checkbox"/> Accumulator: <input type="checkbox"/> Instr. Tubing:				<input type="checkbox"/> Pump Disch.			
Filters: Item No. <input type="checkbox"/> Mfr.:				<input type="checkbox"/> Filter Inlet <input type="checkbox"/> At switches/transmitters			
<input type="checkbox"/> Single <input type="checkbox"/> Dual <input type="checkbox"/> Code Design/Stamp				<input type="checkbox"/> Filter Outlet <input type="checkbox"/> Filter Diff. Press.			
<input type="checkbox"/> Design Pressure/Hydro (psig): /				Level Indicator: <input type="checkbox"/> Mfr.:			
<input type="checkbox"/> Diff. Press. (psi): Clean: Allowable:				<input type="checkbox"/> Reservoir			
<input type="checkbox"/> Filtration Particle Size (microns):				Sight Flow Indicators: <input type="checkbox"/> Mfr.:			
Three Way Transfer Valves: <input type="checkbox"/> Filter <input type="checkbox"/> Cooler				<input type="checkbox"/> Bearing Drain <input type="checkbox"/> Relief Valve Outlet			
<input type="checkbox"/> Filter/Cooler <input type="checkbox"/> Filter <input type="checkbox"/> Cooler				<input type="checkbox"/> Switch/Transmitter Mfg. (Note 1):			
Coolers: Item No. <input type="checkbox"/> Mfr. <input type="checkbox"/> Type:				Switches/Trans: Alarm Shutdown Setpoint			
<input type="checkbox"/> ASME Design/Stamp:				<input type="checkbox"/> Lo L.O. Press. <input type="checkbox"/> Hi L.O. Temp. <input type="checkbox"/> Lo L.O. Level: <input type="checkbox"/> Hi Filt. DP: <input type="checkbox"/> psi			
<input type="checkbox"/> Duty (BTU/hr): <input type="checkbox"/> Surface Area (ft ²):							
<input type="checkbox"/> Temp. Cont. Vlv. Req'd <input type="checkbox"/> Mfg.:							
<input type="checkbox"/> Single <input type="checkbox"/> Dual <input type="checkbox"/> TEMA C <input type="checkbox"/> TEMA R				Turbine: <input type="checkbox"/> Mfr. <input type="checkbox"/> Item No.:			
<input type="checkbox"/> Design/Hydro Press. (psig): Shell: / Tubes: /				<input type="checkbox"/> Strm. Conds. In/Out: / (psig, deg F)			
<input type="checkbox"/> Dimensions (inches): Shell OD: Tubes OD: BWG:				<input type="checkbox"/> Rating (HP): <input type="checkbox"/> Speed (RPM)			
<input type="checkbox"/> Water Flow (gpm): <input type="checkbox"/> Temp. In/Out (F): / <input type="checkbox"/> Fouling Factor: <input type="checkbox"/> Tube Vel. (ft/sec):				Motor: <input type="checkbox"/> Mfr. <input type="checkbox"/> Voltage/Phase/Hz: / / <input type="checkbox"/> Speed:			
<input type="checkbox"/> Max. delta P (psi):				<input type="checkbox"/> Rating (ft): <input type="checkbox"/> Service Factor:			
Accumulator: <input type="checkbox"/> Mfr. <input type="checkbox"/> Capacity (gal):				Inspect. & Testing: Required Witness Test Log			
<input type="checkbox"/> Required: <input type="checkbox"/> ASME Code Design/Stamp:				<input type="checkbox"/> Cleanliness			
<input type="checkbox"/> Type: <input type="checkbox"/> Design/Hydro Press. (psig): /				<input type="checkbox"/> 1 Hour Test Run			
Mounting: <input type="checkbox"/> On equipment skid <input type="checkbox"/> Separate baseplate				<input type="checkbox"/> Check Controls			
<input type="checkbox"/> Dimensions: ft. <input type="checkbox"/> Weight: lbs.				<input type="checkbox"/> Changeovers			
				<input type="checkbox"/> 1 & 2 Pump Op.			
Notes:							
1) Switches shall be SPDT and rated for the specified electrical area classification and be de-energize to alarm and shutdown.							
2) Instruments shall have isolation valves.							

Figure 16. General Purpose Lube Oil System Data Sheet.

"A picture is worth a thousand words." The hydraulic flow schematic is a picture that includes the quantity and orientation of components. If a component is not on the schematic, then it will not be on the system. Schematics, data sheets, and customer specifications are all necessary information to formulate a design for the lube oil system.

CONCLUSION

The North American Reliability Council (NARC) determined that turbine bearing and lube system failures were the leading cause of forced outages in the turbine related failures. Pumps, their drivers, and gears rotate on, and are supported by, the oil film in the hydrodynamic bearing. The life of this equipment and, therefore, the process reliability is a function of a properly designed lube oil system producing the appropriately conditioned oil film.

Detailed data sheets are the beginning to an optimized lube oil system design and component selection to result in a reliable system to maximize revenues for the process pump user.

REFERENCES

- ANSI/NFPA T3.10.8.8, 1994, "Hydraulic Fluid Power-Filters-Multipass Method for Evaluating Filtration Performance," New York, New York.
- API 610 Standard, Eighth Edition, 1995, "Centrifugal Pumps for Petroleum, Heavy Duty Chemical and Gas Industry Services," ANSI/API Std 610-1995, Washington, D.C.
- API 614 Standard, Third Edition, 1992, "Lubrication, Shaft-Sealing, and Control-Oil Systems for Special-Purpose Application," ANSI/API Std 614-1992, Washington, D.C.
- ISO 4406, 1987, "Hydraulic Fluid Power-Fluids-Method for Coating," Geneva, Switzerland.
- NAS 1638, 1992, "Cleanliness Requirements of Parts Used in Hydraulic System," AIA/NAS, Washington, D.C.

