

OVERVIEW OF API 682 SECOND EDITION

by
Michael B. Huebner
Staff Engineer
Flowserve Corporation
Deer Park, Texas



Michael Huebner is a Staff Engineer at Flowserve Corporation, Flow Solutions Division, in Deer Park, Texas. He has more than 20 years experience in the design of mechanical seals, centrifugal and positive displacement pumps, and fluid conditioning equipment. For Flowserve, he has served in design, testing, and application functions in both the U.S. and Europe.

Mr. Huebner is a member of the International Pump Users Symposium Advisory Committee and the API 682 Task Force. He received his B.S. degree (Engineering Technology) from Texas A&M University.

ABSTRACT

API's recent release of Standard 682, Second Edition, represents a major revision to this standard. The latest revision has greatly expanded the scope of the standard by including applications to more pumps, adding new seal types, and creating seal categories. While the standard has changed significantly, the original focus of the standard has remained the same—to guide the user into selecting proven seal technology to successfully seal a variety of applications. This tutorial introduces some of the more significant changes to the Second Edition.

INTRODUCTION

API Standard 682 (1994) was originally published in 1994. This standard was the result of the efforts of a number of key rotating equipment engineers in the refinery industry. The purpose of the standard was to capture proven solutions to the most common sealing applications seen in refineries. There was no attempt to cover every type of rotating equipment or mechanical seal. There was also no attempt to cover every application. Rather the standard was to serve as a guide to selecting seals based on what was working in actual services. In the process, the Task Force had to define a number of key concepts.

The sealing industry had developed with very little effort on standardization between various pump and seal original equipment manufacturers (OEMs). This resulted in a continuous spectrum of seal sizes and designs. There were no standard seal models, design features, materials, or operating windows. Even the nomenclature between seal components was different between different OEMs. Before the 682 Task Force could create a standard, it had to define a great number of concepts related to seals. This included nomenclature, seal types, and seal arrangements. It also created a methodology for seal selections based on process fluids and operating conditions.

This standard has been used around the world on new projects, expansions, and seal upgrades. Its acceptance has been truly international. Since the introduction of the First Edition in 1994, though, there have been many changes in the sealing industry that made a revision to the standard beneficial. First, new seal models (such as dry gas seals and containment seals) have been widely

used in industry. Users had also shown interest in expanding the scope of the standard to include pumps commonly used in chemical industries. The application of the First Edition created international challenges since it was written primarily defaulting to other American standards such as ANSI and ASME. The API Task Force was given the assignment of taking a very successful First Edition and creating an updated and expanded Second Edition that would address these issues.

GENERAL

At first glance, there is very little in common between the First Edition and Second Edition other than the size of the document. This is because the standard has been completely reorganized in preparation for its publication as an ISO standard (ISO 21049). This has resulted in a completely different arrangement and numbering of the document. Any references to specific clauses or appendixes from the First Edition will not be correct in the Second Edition. Upon closer examination, the reader will find most of the information from the First Edition is still there although there have been significant additions in many areas. Although this tutorial covers many of these additions, the reader should review the standard for a thorough understanding of the requirements of the Second Edition.

DIMENSIONS

Since the Second Edition has been written as an ISO standard, all dimensional data have been presented in SI units. US customary units are also given in parentheses as a secondary reference. The user will specify whether data, drawings, hardware (including fasteners), and equipment supplied to this standard will use SI units or US customary units.

SEAL CATEGORIES

Seal categories are “subspecifications” within the Second Edition. Before defining a category, it would be helpful to understand why they were created. The First Edition specified a seal designed for demanding services. This included features such as a distributed flush arrangement and floating throttle bushing on all single seals. These features made these seals larger and more costly than required for many general duty applications. For these applications, some users have specified seals that had only some of the features required on a standard seal. Customers referred to these seals as being designed “in the spirit of 682” or with the “intent of 682.” It was clear that all the features required by the First Edition were not required for every application. As the standard was expanding the scope to include more chemical pumps, it was seen as inevitable that this practice would continue.

It was also critical to recognize that chemical duty pumps and their seals were intended to be applied in a smaller operating window than the traditional First Edition seals. Most chemical duty pumps are designed to operate at lower pressures and temperatures than the API 610 pumps so it was consistent to create a seal category that reflected the pumps' capabilities.

A seal category is a subspecification that defines the intended pump, operating window, materials, design features, and documentation requirements for the seal. There are three categories

defined as Category 1, 2, and 3. A Category 1 seal is a seal intended for chemical duty pumps. A Category 2 seal is intended for API 610 (ISO 13709) pumps in refinery services requiring fewer features than a 682 First Edition seal. The Category 3 seal is intended for API 610 pumps and is basically the same seal defined in the First Edition. Table 1 outlines some of the features and requirements for each category.

Table 1. Comparison of Features of Categories.

Feature	Category 1	Category 2	Category 3
Seal chamber size	ANSI ASME B73.1 and B73.2, ISO 3069 Frame C	API-610, ISO 13709	API-610, ISO 13709
Temperature range	-40°F to 500°F	-40°F to 750°F	-40°F to 750°F
Pressure range, absolute	315 PSI	615 PSI	615 PSI
Face materials	Premium blister resistant carbon versus self sintered silicon carbide	Premium blister resistant carbon versus reaction bonded silicon carbide	Premium blister resistant carbon versus reaction bonded silicon carbide
Distributed flush required for single seals with rotating flexible elements	When specified by purchaser or required in low vapor pressure margin applications	When specified by purchaser or required in low vapor pressure margin applications	Required
Throttle bushing requirements for single seals	Fixed carbon bushing required. Purchaser may specify floating carbon bushing	Fixed non-sparking metal bushing required. Purchaser may specify floating carbon bushing	Floating carbon bushing required
Scope of vendor qualification test	Tested as Category 1 seal unless faces are interchangeable with previously tested seals	Tested as Category 2 seal unless faces are interchangeable with previously tested seals	Testing required as complete cartridge assembly
Proposal data requirements	Minimal	Minimal	Rigorous
Contract data requirements	Minimal	Minimal	Rigorous

SEAL TYPES

The seal type defines the basic design of a seal as well as the materials of construction. These are largely unchanged from the First Edition. Seal types are defined as Type A, B, or C. A Type A seal is a pusher seal with a rotating flexible element, silicon carbide versus carbon faces, alloy C-276 springs, fluoroelastomer O-rings, and 316SS metal components (Figure 1). A Type B seal is a bellows seal with a rotating flexible element, silicon carbide versus carbon faces, alloy C-276 diaphragms, fluoroelastomer O-rings, and 316SS metal components (Figure 2). A Type C seal is a bellows seal with a stationary flexible element, silicon carbide versus carbon faces, alloy 718 diaphragms, flexible graphite secondary seals, and 316SS metal components (Figure 3).

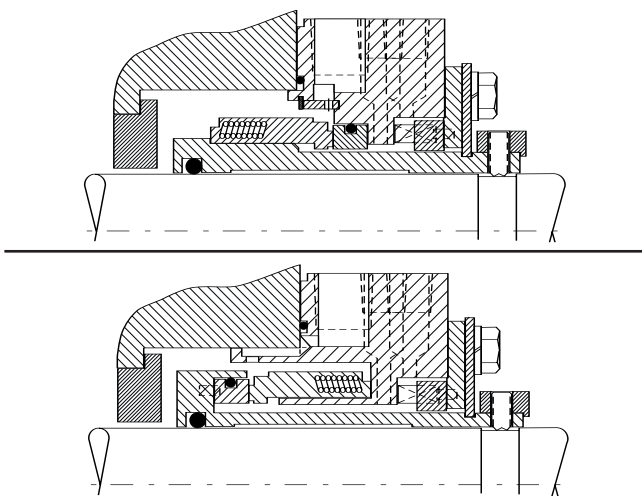

Figure 1. Standard and Alternative Type A Seal.

In the First Edition, all seals were assumed to be contacting wet seals. Although there have been many lively discussions about whether standard liquid mechanical seals are contacting or not, for the purpose of this standard they are designated as contacting wet (or "CW") seals. The Second Edition introduces two other seal designs: the containment seal and the noncontacting seal.

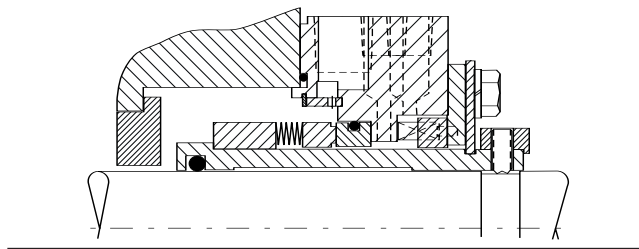

Figure 2. Standard and Alternative Type B Seal.

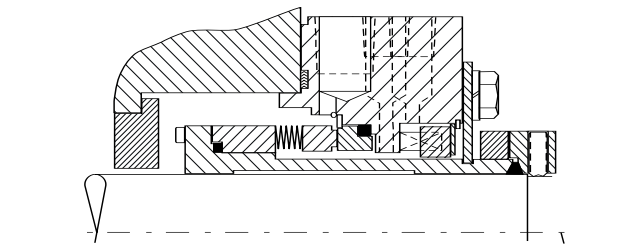
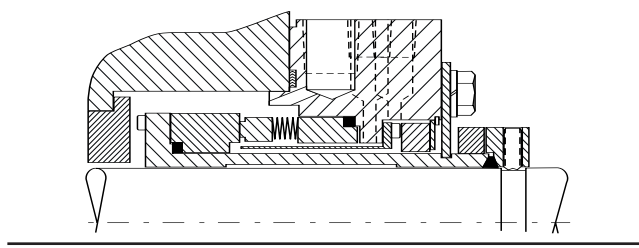

Figure 3. Standard and Alternative Type C Seal.

A containment seal is a backup seal in a dual unpressurized seal arrangement. It is designed to operate at less than 10 psi for the life of the inner seal. When the inner seal fails, the containment seal is designed to run under full seal chamber conditions for a minimum of eight hours and prevent or minimize process fluid leakage to atmosphere. The containment seal is designated as "CS."

A noncontacting seal is a seal that is designed to intentionally create a hydrodynamic lift and operate with a specific face separation. This design is used primarily on dual pressurized gas seals. It may also be used on liquid or mixed phase applications. This seal design is designated as "NC."

SEAL ARRANGEMENTS AND CONFIGURATIONS

A seal arrangement defines the number of seals in the cartridge and the pressure in the cavity between dual seals. In the First Edition, seal arrangements were relatively straightforward. An Arrangement 1 seal was a single seal. An Arrangement 2 seal was a dual seal in a series (face-to-back) orientation. The buffer fluid cavity between the two seals was maintained at a pressure lower than seal chamber pressure. An Arrangement 3 seal was a dual seal in a series (face-to-back) orientation with a barrier fluid pressure greater than the seal chamber pressure.

In the Second Edition, the same definitions of arrangement apply although there are more options available due to the inclusion of containment seals and noncontacting seals. This made it necessary to introduce the concept of the seal configuration. The

configuration is a subset of the arrangement and it defines the function of the seal (contacting wet, noncontacting, or containment seal). It may also define the type of bushing (on a single seal) or the orientation on Arrangement 3 seals. An example of a configuration is 1CW-FL. This would be interpreted as an Arrangement 1 seal where the inner seal is a contacting wet (or CW) seal with a floating (FL) bushing. A 2CW-CW seal is interpreted as an Arrangement 2 seal where the inner and outer seals are both contacting wet (CW) seals.

Arrangement 3 seals have the most options. These seals can be provided as dual pressurized liquid seals in a variety of orientations. These are contacting wet seals (CW) in a face-to-back (FB), back-to-back (BB), or face-to-face (FF) orientation. A 3CW-FB is an Arrangement 3 contacting wet seal in a face-to-back orientation. Arrangement 3 seals can also be provided as dual noncontacting gas seals (gas barrier fluid) in a variety of orientations. A 3NC-BB is an Arrangement 3 noncontacting seal in a back-to-back orientation. The relationship between seal arrangements and configurations is shown in Figure 4.

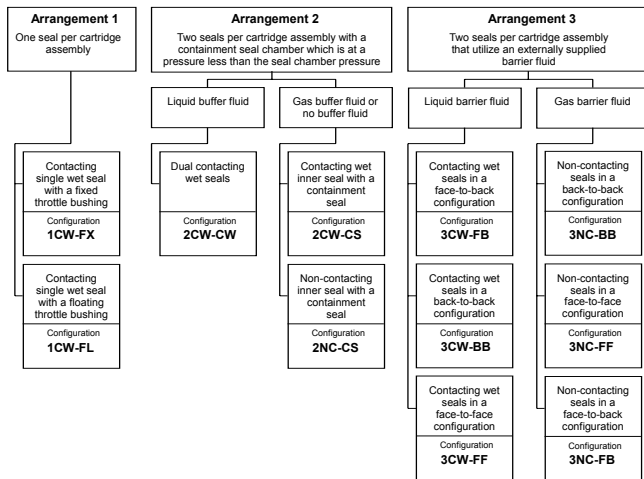

Figure 4. Seal Configurations.

On Arrangement 3 seals, the order of the configurations shown in Figure 4 designates the order of preference as defined by the standard. The default configuration for a dual pressurized, contacting wet seal is in a face-to-back orientation (3CW-FB). This was the default Arrangement 3 from the First Edition. For a dual pressurized, noncontacting seal, the default configuration is a back-to-back orientation (3NC-BB).

DESIGN REQUIREMENTS—GENERAL

The Second Edition states that the “standard does not cover the design of the component parts of mechanical seals...” This refers to the requirements that are typically covered in standards such as allowable stress levels and deformations. The standard does however contain a great number of requirements covering everything from O-ring sealing surfaces to drive collars. The majority of the design requirements are unchanged from the First Edition. Some of the changes are noted below.

One of the significant changes is the separation of pump and seal standards. Both the API 610 and API 682 Task Forces made efforts to remove redundancies between the two standards. In API 610 (1995), most seal requirements, the seal code, and seal piping plans have been eliminated with a reference made to API 682. In API 682, Second Edition (2002), all shaft and seal chamber tabulations have been eliminated. All references to seal chambers and pump requirements are made back to the original pump specification. This is also consistent with the inclusion of ASME B73 and ISO 3069 Frame C seal chambers. The only pump requirements remaining in the standard pertain to the interface between the pump and the seal.

In the First Edition, process connection sizes, orientations, and markings were specified for the three arrangements. In the Second Edition, the greater number of configurations along with the different seal categories has resulted in an extensive chart detailing the required connections. One of the key objectives is to eliminate the potential for connecting process piping to atmospheric connections. In the First Edition, this was accomplished by making all process connections 3/4 NPT and all atmospheric connections 3/8 NPT. In the Second Edition, most process connections are 1/2 NPT, atmospheric connections are 3/8 NPT, and liquid barrier/buffer fluid connections are 1/2 or 3/4 NPT (depending upon the shaft diameter).

There are also a greater number of possible connections in the Second Edition. This has resulted in different connection symbols. Table 2 shows these differences. All other connections such as flush (F), cooling (C), drain (D), and quench (Q) remain the same.

Table 2. New Connection Symbols.

Symbol Description	
FI	Flush In (Plan 23 only)
FO	Flush Out (Plan 23 only)
LBI	Liquid Barrier/Buffer Fluid In
LBO	Liquid Barrier/Buffer Fluid Out
GBI	Gas Barrier/Buffer Fluid In
GBO	Gas Barrier/Buffer Fluid Out
CSV	Containment Seal Vent
CSD	Containment Seal Drain

In addition to the sizes and symbols for connection, the Second Edition also specifies the angular orientation of the connections when viewed from the end view of the seal. All connections that are self-venting (such as the flush, buffer/buffer fluid outlets, and flush outlets) are located at the top of the seal (or zero degrees). All connections that function as a drain (such as the drain and containment seal drain) are located at the bottom of the cavity (or 180 degrees). These locations are defined as the location where the connection intersects the cavity. This does not require the actual connection port to be at this location on the outside diameter (OD) of the seal gland. This is especially true for tangential ports where the piping will connect to the gland at some angle off vertical.

The First Edition specified clearances between the inside diameter (ID) of the seal sleeve and the OD of the shaft to be between 0.001 and 0.003 inch including tolerances on both parts. This was independent of the shaft diameter. Depending upon the tolerances of both parts, this could lead to clearances under 0.001 inch. On larger diameter seals, this created installation and removal problems in the field. In the Second Edition, the allowable clearance (along with the tolerances on the sleeve and shaft) are defined as F7/h6 according to ISO 286-2. This has resulted in clearances up to 0.0037 inch on the larger seal sizes.

The First Edition specified that the default material for all seal faces was premium grade, blister-resistant carbon versus reaction bonded silicon carbide. For seals requiring two hard faces, the default face materials were reaction bonded silicon carbide versus nickel bound tungsten carbide. In the Second Edition, there is a difference between materials for different seal categories. Since a Category 1 seal will typically be used in a chemical pump, the default face materials are premium grade, blister-resistant carbon versus self-sintered silicon carbide. Categories 2 and 3 are the same as the First Edition (premium grade, blister-resistant carbon versus reaction bonded silicon carbide). For seals requiring two hard faces, the default material for both faces is silicon carbide.

ACCESSORIES

Seal Coolers

A seal cooler is used to reduce the temperature of the fluid in the seal chamber. This is often done to increase vapor pressure or improve fluid properties for the seal. The First Edition outlined some of the construction details for seal coolers. In general, all seal coolers had to be designed with process fluid on the tube side and cooling water on the shell side. Both the tube and shell sides had to be completely drainable. Piping for the tube was required to be $\frac{3}{4}$ inch tube with a minimum 0.095 inch wall thickness.

The Second Edition maintains these requirements but adds an additional smaller size cooler for smaller shafts. For shaft sizes of 2.500 inches or less, a cooler with $\frac{1}{2}$ inch tubing and a minimum wall thickness of 0.065 inch should be used. For shafts larger than 2.500 inches, a seal cooler with $\frac{3}{4}$ inch tubing and a minimum 0.095 inch wall thickness should be used. Of course, the primary consideration in selecting a seal cooler must be adequate heat removal. This may result in a larger seal cooler being applied to seal with a shaft diameter under 2.500 inches.

Barrier/Buffer Fluid Reservoirs

Reservoirs are used on Plan 52 and Plan 53A piping plans to provide buffer and barrier fluids to the seals. The First Edition had detailed requirements for the dimensions, materials, and instrumentation for these reservoirs. One of these requirements was that the volume of the barrier fluid in the system at the normal liquid level was five gallons. The Second Edition maintains most of the same requirements for reservoirs but has added a smaller size reservoir for smaller shaft sizes. For shafts with a diameter of 2.500 inches and smaller, the standard reservoir shall have a capacity of three gallons at normal liquid levels. For shafts larger than 2.500 inches, the capacity should be a minimum of five gallons as detailed in the First Edition.

Condensate Collection Reservoir

The condensate collection reservoir is a vessel used to collect leakage from a Plan 75 system. This reservoir not only collects the leakage, it provides a place for liquid and gas phase leakage to separate and be piped to the appropriate recovery system. The reservoir will also be instrumented to monitor inner seal leakage through both the liquid level and pressure in the reservoir. The standard provides details of the construction for this vessel.

Barrier/Buffer Gas Supply Panels

Gas supply panels are used on Plan 72 and Plan 74 systems to provide a filtered regulated inert gas to the mechanical seals. The supply panels must have, at a minimum, a pressure regulator, coalescing filter, flow meter, low pressure switch, pressure gauge, check valve, and isolation valve. A typical arrangement for these components is shown in Figure 5. The purchaser and seal OEM shall mutually agree on the instrumentation and general arrangements for the panel.

SEAL QUALIFICATION TESTS

The First Edition introduced the concept of the standardized seal qualification test. Since one of the goals of the standard was to provide seals with high probability of achieving three years of uninterrupted service, it was natural to try to obtain some objective evidence that this could be accomplished. Seal testing was done on a number of representative fluids under common operating conditions. In addition to steady-state operation, there were a number of starts and stops along with pressure and temperature variations to evaluate the seals on real world conditions.

The Second Edition has continued with this philosophy and introduced qualification testing for containment seals and dual gas seals. Containment seals are designed for long runs under relatively low duty conditions. Their function during this stage of

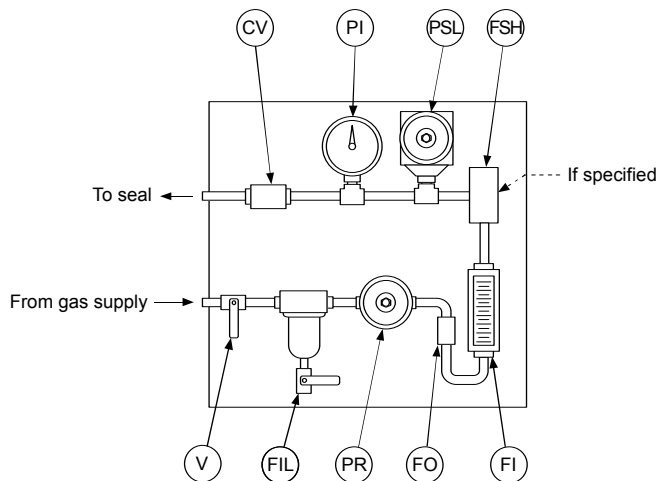

Figure 5. Typical Barrier/Buffer Gas Supply Panel.

operation is to isolate the containment seal cavity from atmosphere. Per the standard, the pressure in the seal cavity should be less than 10 psi. The containment seal's real work begins when the primary seal fails. In this condition, the containment seal may be operating on high pressure vapors or process fluids. The qualification testing is designed to simulate normal operation as well as failure of the inner seal. Leakages and pressure drops are monitored and recorded at key points during the testing. The containment seal test sequence is shown in Figure 6.

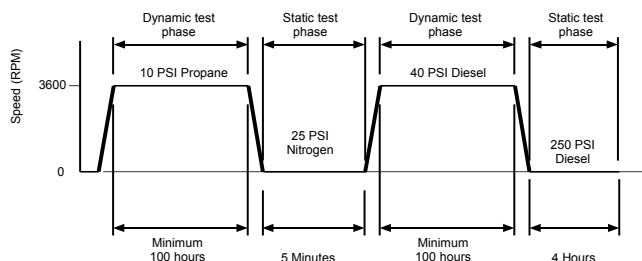

Figure 6. Containment Seal Test Sequence.

Dual gas seals are designed to run with barrier gas maintained at a pressure higher than the seal chamber pressure. In actual service, there may be interruptions in the gas supply that could affect seal performance. Qualification testing for these seals includes steady-state testing under the same conditions outlined for liquid seals. This includes starts and stops along with variations in the pressure and temperature of the process fluid. After completing this testing, the seal is exposed to upsets in the barrier gas supply. The first phase simulates a complete loss of barrier gas pressure under static conditions for one hour. The seal is then repressurized and tested at 3600 rpm. During testing, the barrier pressure is isolated from the supply pressure and allowed to decay while the seal continues operation. The pressure is reestablished and allowed to reach equilibrium. The tester is then stopped, the seal isolated, and pressure decay measured for 10 minutes. Leakages and pressure drops are also monitored and recorded at key points during operations. The dual gas seal test sequence is shown in Figure 7.

All testing of liquid seals performed under the First Edition is valid for the Second Edition with one caveat. The First Edition did not define an acceptance criterion for the seals during testing. Basically, it was up to the seal OEM to determine if the seal was suitable for the service. While it is still the seal OEMs responsibility to ensure an acceptable seal, there is now an acceptance criterion. During testing, the seals must maintain a leakage rate of less than 1000 ppm (as measured by EPA Method 21) or 5.6 gr/hr. This leakage criterion does not apply to testing of dual gas seals or

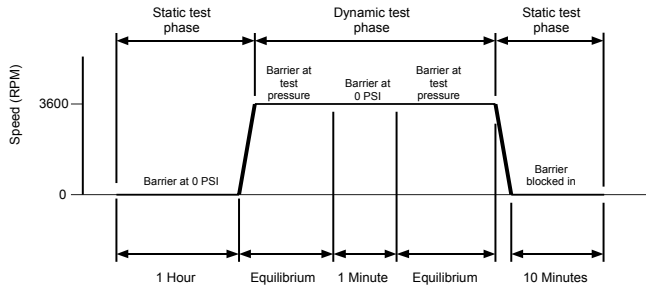

Figure 7. Dual Gas Seal Test Sequence.

containment seals under failure conditions. In addition, the measured wear on the seal faces must be less than 1 percent of the available wear.

HYDROSTATIC TEST

Hydrostatic testing is required for all the pressure boundary of the seal and support system. This includes the seal gland, all piping, reservoirs, and other auxiliary equipment exposed to process fluids. In the Second Edition, there is an exemption for seal glands machined from a single piece of wrought material or bar stock. Cast seal glands still require testing.

ANNEX A—RECOMMENDED SEAL SELECTION PROCEDURE

The seal selection procedure was introduced in the First Edition to give guidance to the user in selecting a seal for a specific application. These applications, as well as the procedures, are broken down into three process fluids: nonhydrocarbon, nonflashing hydrocarbon, and flashing hydrocarbon. The procedure goes through a number of steps including selection of the seal type, arrangement, and piping plan. The selection procedure has been revised for the Second Edition to include the new seal designs and categories. It also has a greater focus on the selection of the seal arrangement.

ANNEX D—STANDARD FLUSH PLANS AND AUXILIARY HARDWARE

Annex D contains all the standard piping plans for mechanical seals. While most of these piping plans were also in the First Edition, there have been several changes to reflect different technologies and address the requirements of the new seal designs.

PLAN 14

Plan 14 is a combination of a Plan 11 and a Plan 13 (Figure 8). This is most commonly used on vertical pumps where there is a need to provide a flush to the seal chamber while continually venting back to suction. This plan was included in API 610, Eighth Edition (1995), and has now been moved in API 682, Second Edition (2002).

PLAN 53

A Plan 53 is a dual pressurized liquid seal support system. In the First Edition, this was defined as a reservoir that is pressurized by an inert gas. While this is the most common method of providing a Plan 53, other options also exist. It was difficult to specify these options, though, since there were no recognized designations for them nor any standardized details on piping and instrumentation. The Second Edition has addressed this by defining three variations of the Plan 53: Plan 53A, 53B, and 53C. These variations are considered as technically equivalent. If the user specifies a Plan 53, any of these variations may be provided.

Plan 53A

This is the Plan 53 as defined in the First Edition. Barrier fluid is maintained in a reservoir and circulated by the mechanical seal

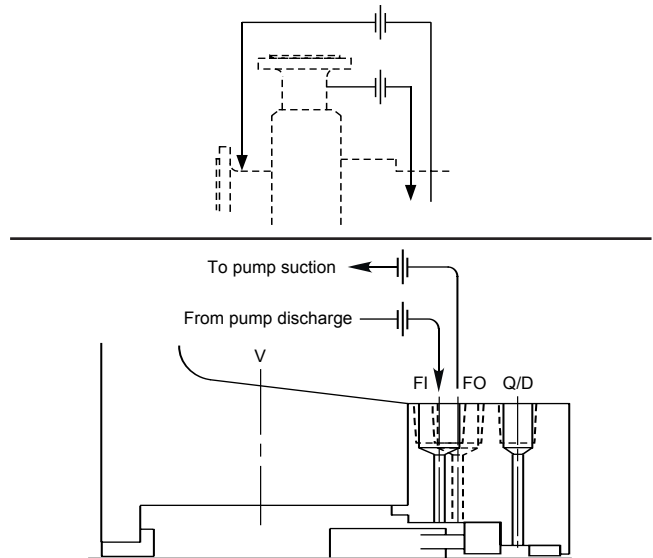

Figure 8. Standard Seal Flush Plan 14.

(Figure 9). The barrier fluid is pressurized by an external source such as a regulated supply of nitrogen. The reservoir serves to remove heat from the barrier fluid as well as provide makeup fluid for normal seal losses. Excessive seal leakage is detected by a change in fluid level in the reservoir. The primary disadvantage of this plan is that there is an interface between the pressurization gas and the barrier fluid. At higher pressures, this can lead to significant gas absorption into the barrier fluid resulting in poor seal performance.

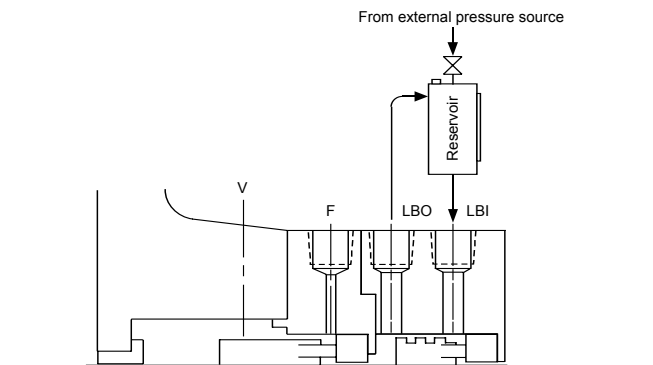
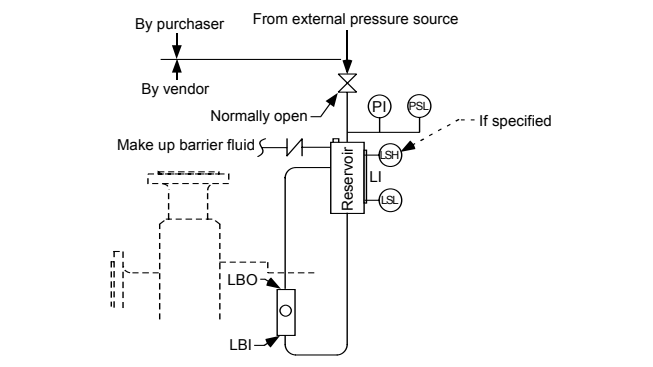

Figure 9. Standard Seal Flush Plan 53A.

Plan 53B

This plan replaces the reservoir with a bladder accumulator (Figure 10). The accumulator provides both pressurization of the barrier fluid and makeup fluid to compensate for normal seal

losses. The bladder separates the pressurization gas from the barrier fluid preventing absorption of the gas at high pressures. Since the bladder is precharged with the pressurization gas, the plan can be operated without a permanent connection to an external gas supply. The barrier fluid is circulated by the seal through a loop that includes a seal cooler and other instrumentation. Excessive leakage is detected by a drop in the pressure in the seal loop. This plan is normally more expensive than a Plan 53A.

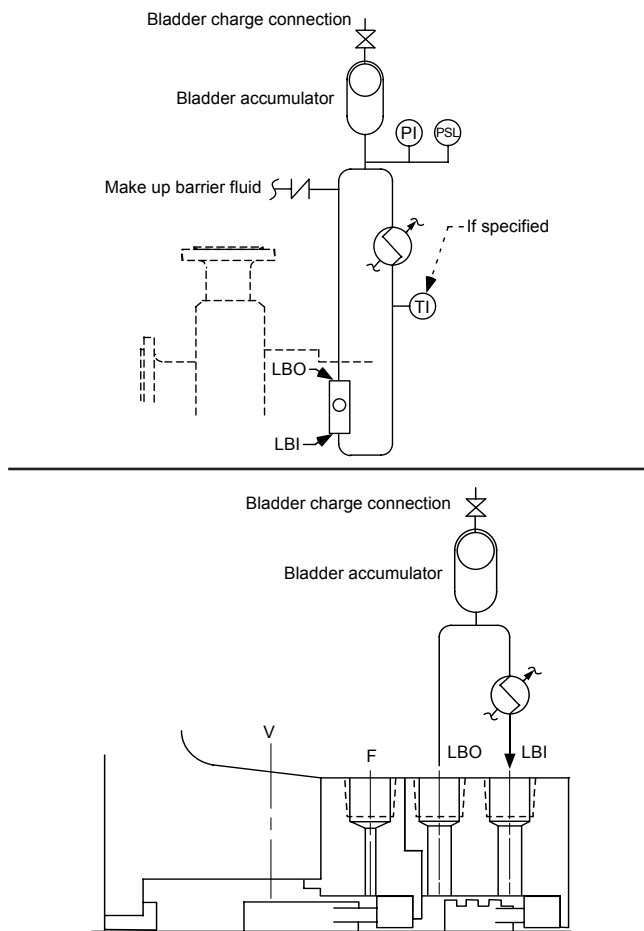

Figure 10. Standard Seal Flush Plan 53B.

Plan 53C

Another variation of this plan uses a piston accumulator (Figure 11). Pressure from a reference source (normally the seal chamber) is piped to the bottom of the piston accumulator. Due to the differences in the areas on the piston, a higher pressure is generated at the top of the accumulator. This is piped into a seal loop. Like the Plan 53B, the barrier fluid is circulated by the mechanical seal through a seal cooler. With no pressurization gas, there is no chance of gas absorption into the barrier fluid. Since the piston accumulator pressurizes the barrier fluid based on the reference pressure, the barrier pressure automatically tracks actual operating conditions including system upsets. One of the disadvantages of this system is that the accumulator is exposed to process fluid. This is a concern in corrosive or abrasive applications. In addition, this plan is generally more expensive than either the Plan 53A or 53B.

PLAN 71

The 70 series of piping plans addresses piping requirements of dual gas seals and containment seals. Plan 71 is designated for seals where the containment seal cavity is run dead-ended (Figure 12). It will also be used when no other containment seal piping has been specified and the connections are plugged for purchaser's use.

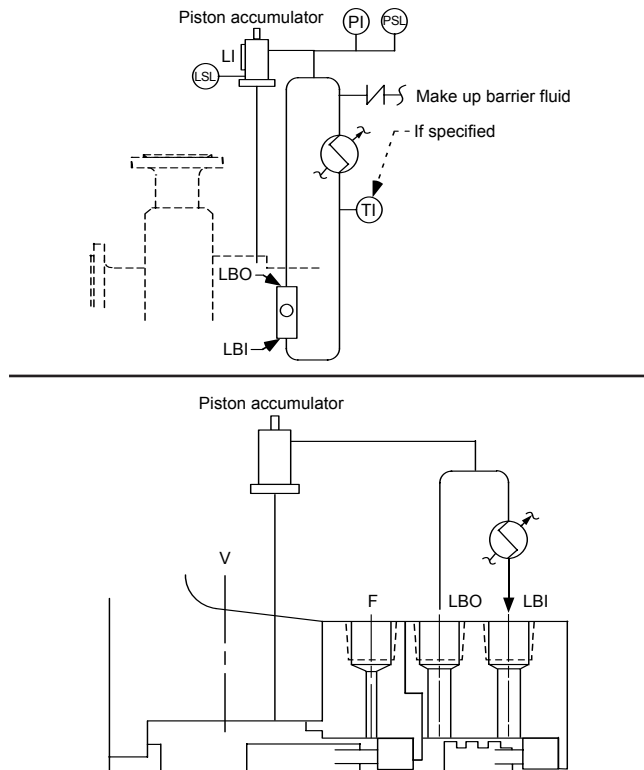

Figure 11. Standard Seal Flush Plan 53C.

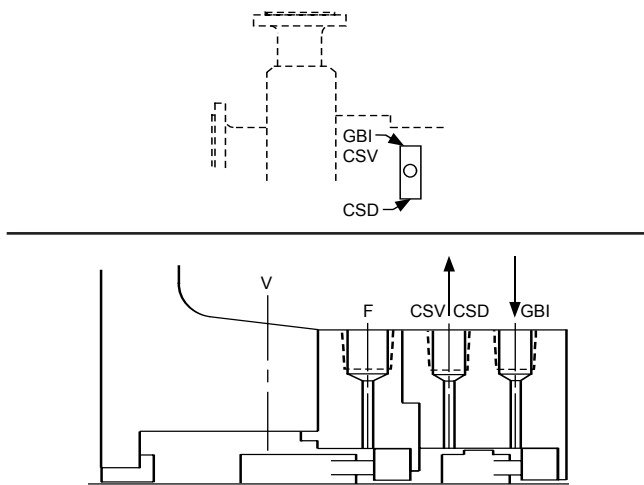

Figure 12. Standard Seal Flush Plan 71.

PLAN 72

Plan 72 is an external buffer gas supplied to the containment seal cavity through a control panel (Figure 13). This plan is provided when it is beneficial to sweep the containment seal cavity with an inert gas. Buffer gas is maintained at a pressure lower than seal chamber pressure and less than 10 psi. This plan is almost always used in conjunction with a Plan 75 or 76 to sweep the buffer gas and seal leakage into a closed collection system. Requirements for the control panel are detailed in the standard.

PLAN 74

Plan 74 is an external barrier gas supplied to a dual pressurized gas seal (Figure 14). Barrier gas is provided at a pressure higher than seal chamber pressure to positively prevent process fluids from leaking to atmosphere. Normally an inert gas such as plant

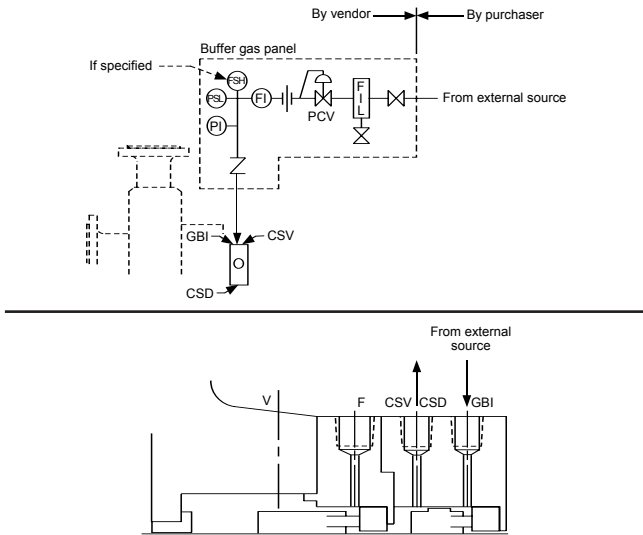

Figure 13. Standard Seal Flush Plan 72.

nitrogen is used as the barrier gas. Requirements for the control panel are detailed in the standard.

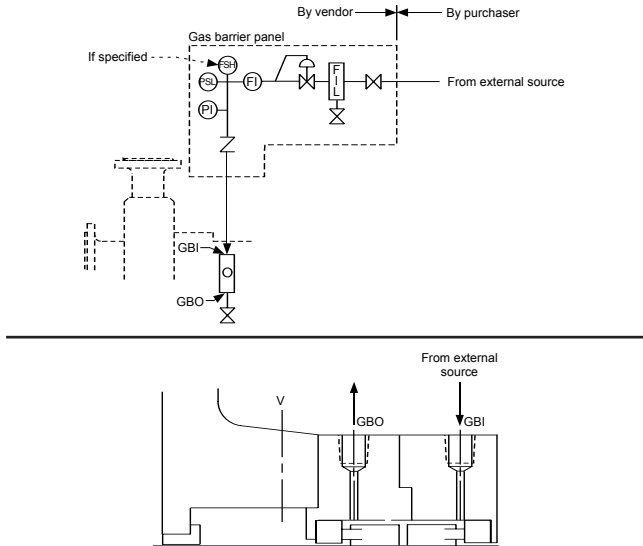

Figure 14. Standard Seal Flush Plan 74.

PLAN 75

A Plan 75 is used to collect leakage into the containment seal cavity when the process fluid does not completely vaporize (Figure 15). This leakage may be liquid phase or a mixture of liquid and vapor phases. The accumulation of liquid leakage in a containment seal cavity may adversely affect seal performance so all leakage should be drained from the low point drain at the bottom of the containment seal cavity. The leakage is piped to a collection reservoir that is connected to liquid and vapor recovery systems. Inner seal performance is monitored by pressurization of the reservoir and by monitoring the liquid level in the collection reservoir. The inner seal can also be tested by blocking in the reservoir and noting the time/pressure buildup relationship in the reservoir. Requirements for the reservoir are detailed in the standard. This plan may be used by itself or in conjunction with a Plan 72.

PLAN 76

A Plan 76 is used to collect leakage into the containment seal cavity when the process fluid completely vaporizes (Figure 16). Since containment seals are normally used to prevent or minimize process

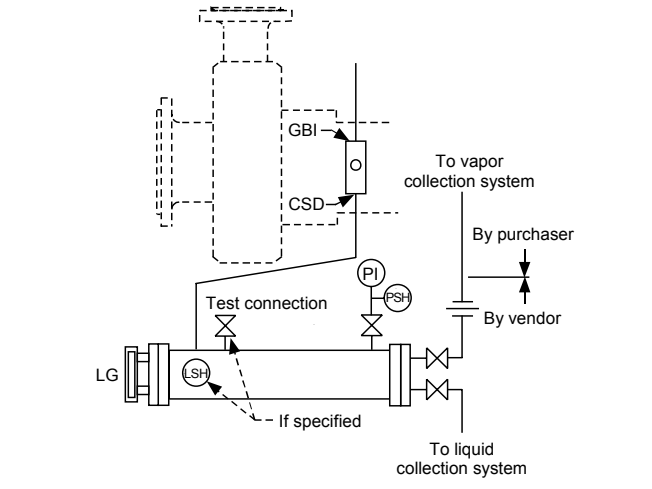

Figure 15. Standard Seal Flush Plan 75.

leakage to atmosphere, the containment seal cavity is piped into a vapor recovery or flare system. High leakage rates past the inner seal will result in a pressure increase between the seal and the orifice in the piping. This will be detected by the pressure indicator and high pressure switch indicating failure of the inner seal. Specification for the piping and instrumentation are detailed in the standard. This plan may be used by itself or in conjunction with a Plan 72.

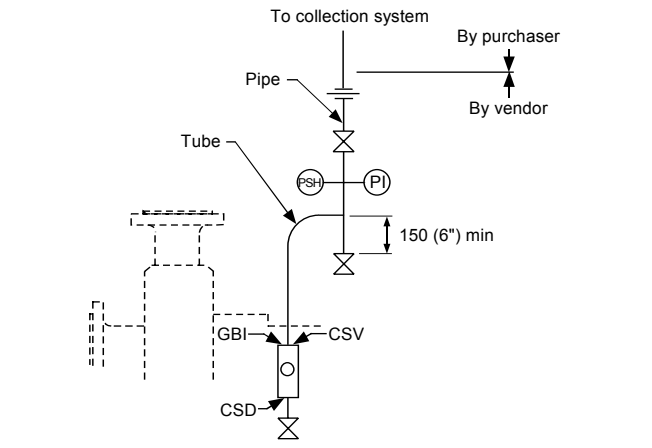

Figure 16. Standard Seal Flush Plan 76.

ANNEX F—MECHANICAL SEAL DATASHEETS

The First Edition introduced a very comprehensive set of seal data sheets. This consisted of five pages of seal data plus two additional pages of pump data. While they were thorough, users seldom, if ever, completely filled these out. The Second Edition revised these data sheets so that all the necessary information is contained on two pages. Since the data requirements and design options are different for different seal categories, there are two sets of data sheets. One set of data sheets covers Category 1 and 2 seals and one set covers Category 3 seals. These data sheets are provided in both SI and US customary units.

ANNEX J—MECHANICAL SEAL CODE

Historically, many seal users have relied on the old API 610 (1995) coding for general designations of mechanical seals. The code BSTFN (and its many variations) can still be seen on seal and pump data sheets today. While this code was useful, it does not convey information that is required on seal selections in API 682. Before developing the new code, the Task Force investigated who was using seal codes. It was determined that the primary users were engineering contractors working on projects. During the project stage, operating conditions for the pump are defined, but very little is known about the equipment that will be used for the application.

At the project stage, the Task Force identified four key pieces of information that will be required for the seal OEM to select a seal: the seal category, the arrangement, the seal type, and the piping plan. The first position of the code defines the category and is designated as C1, C2, or C3. The second position defines the arrangement and is designated as A1, A2, or A3. The third position defines the seal type and is designated as A, B, or C. The last position defines the piping plan(s) and is designated by the two digit piping plan number. If more than one plan is required (such as on dual seals), the additional plans are added to the end of the code.

An example of a new seal code is C1A1A11. This is interpreted as Category 1 (C1), Arrangement 1 (A1), Type A (A) seal with a Plan 11. An example of a dual seal with multiple piping plans is C3A2A1176. This is interpreted as a Category 3, Arrangement 2, Type A seal with a Plan 11 on the inner seal and a Plan 76 on the outer seal.

One of the comments made about the new code is that it does not include information about seal face and gasket materials. The Task Force considered this and concluded that all seal types have a default set of materials defined in the standard. If the user desires to specify alternative materials, these will need to be defined outside the seal code.

CONCLUSIONS

This tutorial provides a quick glimpse of the many changes in API 682, Second Edition (2002). The user is encouraged to review a copy of the revised standard to determine the extent of the changes and its effect on their organization. Overall, the Second Edition will allow the benefits of API 682 to be applied to a greater number of applications and be used more easily in a global market.

REFERENCES

- API Standard 610, 1995, "Centrifugal Pumps for Petroleum, Heavy Duty Chemical and Gas Industry Services," Eighth Edition, American Petroleum Institute, Washington, D.C.
- API Standard 682, 1994, "Shaft Sealing Systems for Centrifugal and Rotary Pumps," First Edition, American Petroleum Institute, Washington, D.C.
- API Standard 682, 2002, "Pumps—Shaft Sealing Systems for Centrifugal and Rotary Pumps," Second Edition, American Petroleum Institute, Washington, D.C.

BIBLIOGRAPHY

- Huebner, M. B., Thorp, J. M., Buck, G. S., and Fernandez, C. L., 2002, "Advances in Mechanical Sealing—An Introduction to API 682 Second Edition," *Proceedings of the Nineteenth International Pump Users Symposium*, Turbomachinery Laboratory, Texas A&M University, College Station, Texas, pp. 59-65.

ACKNOWLEDGEMENT

The author would like to thank the American Petroleum Institute for its cooperation and permission to reproduce figures for this tutorial. Special thanks go to Andrea Johnson for her "behind the scenes" work at API during the creation of this standard.