

**TUTORIUM  
ON  
TURBOMACHINERY LUBRICATION**

**Tutorium Leaders:**

**Allen M. Clapp**  
Dow Chemical U.S.A.  
Freeport, Texas

**Fredrick B. Wilcox**  
Shell Oil Company  
Houston, Texas



# PLANT LUBRICATION

by

**Allen M. Clapp**

Supervisor, Lubrication Technical Services

Dow Chemical U.S.A.

Freeport, Texas



*Allen M. Clapp is the supervisor of Lubrication Technical Services for Dow Chemical U.S.A., Texas Division, at Freeport, Texas. He is responsible for the division's lubrication programs and the lubrication training of plant personnel. He is also responsible for the evaluation of new lubricants and the development of lubrication procedures and methods of application.*

*He is a member of the American Society of Lubrication Engineers and currently an executive committee member of the ASLE Petroleum and Chemical Industry Council.*

## ABSTRACT

The correct lubrication of plant equipment is an important factor in sustaining production with reduced equipment outage and lower maintenance costs. A well planned and coordinated lubrication program is a necessary prerequisite for any preventive maintenance program that may be established by a production plant.

This paper deals largely with applied lubrication in the petro-chemical industry, including turbomachinery. Many of the comments expressed are based on personal experience by the author on equipment operating in a chemical complex on the Gulf Coast of Texas.

Many procedures and approaches to plant lubrication are discussed, including the initiation of a computer assisted lubrication program, sampling and testing oil from critical machinery and specific procedures to apply lubricants to a variety of process machinery, including constant level oilers, electric motors and grease lubricated couplings. Special emphasis is made on the prevention of water and process gasses as contaminants in oil systems on turbomachinery.

## INTRODUCTION

The correct lubrication of plant equipment is an important factor in sustaining production with reduced equipment outage and lower maintenance costs. When a well planned and coordinated lubrication program has been established, the production plant has an effective preventive maintenance program at work. A complete lubrication program will encompass all phases of plant lubrication.

This paper deals largely with applied lubrication for equipment in the petro-chemical industry, including turbomachinery. The subjects that will be discussed are shown in Figure 1. Many of the comments expressed will be opinions based on personal experience for equipment and lubrication systems exposed to environmental and operating conditions in our complex located on the Gulf Coast at Freeport, Texas.

The need for protecting the operating equipment against excessive wear and for keeping plant delays to the absolute

1. LUBRICATION SURVEYS
2. LUBRICANT CONSOLIDATION
3. LUBRICATION SCHEDULES
4. LUBRICANT HANDLING AND STORAGE
5. OIL SAMPLING AND TESTING
6. EVALUATION OF NEW LUBRICANTS
7. LUBRICATION TRAINING
8. LUBRICATION METHODS

*Figure 1. Topics.*

minimum brings lubrication into a very prominent position in the operation. All moving parts of the equipment require lubrication to permit it to function successfully and contribute its part toward high plant production. This can only be achieved when a complete "Lubrication Program" has been established and maintained.

The success of any plant-wide lubrication program depends upon the close cooperation among certain individuals and groups of individuals within the various units and divisions of the organizational structure, including: Operating, Maintenance, Engineering and Lubrication personnel. In addition, valuable technical assistance can be obtained from the equipment manufacturer and the lubricant supplier.

## LUBRICATION SURVEY OF THE PLANT

If the plant has not recently been surveyed from a lubrication standpoint, a careful survey should be conducted to determine the current lubrication practices.

The main part of this survey will consist of a detailed lubrication inspection of all plant equipment as shown by Figure 2. Each machine must be studied and its various lubrication points listed by name, such as: electric motor bearings, flexible couplings, reduction gears and bearings, etc. The name of the lubricant being used, together with the means and frequency of application also should be listed for each lubrica-

- |  |   |
|--|---|
| <ol style="list-style-type: none"> <li>1. INVENTORY MACHINERY</li> <li>2. MACHINE CHARACTERISTICS</li> <li>3. POINTS OF LUBRICATION</li> <li>4. METHODS OF LUBRICATION</li> <li>5. FREQUENCY OF LUBRICATION</li> </ol> | <ol style="list-style-type: none"> <li>1. LIST LUBRICANT TYPES           <ul style="list-style-type: none"> <li>... COMMON NAME</li> <li>... IDENTITY CODE</li> </ul> </li> <li>2. DETERMINE GENERAL CHARACTERISTICS           <ul style="list-style-type: none"> <li>... SUPPLIER</li> <li>... LABORATORY TESTING</li> </ul> </li> </ol> |
|--|---|

*Figure 2. Lubrication Survey.*

tion point. Likewise, any abnormal conditions encountered such as excessive oil leakage, water entering the oil, frequent bearing changes and the like should be recorded.

Obtaining this data is time consuming and several days may be required to survey the plant. However, such a survey is the only way of obtaining an accurate picture of current lubrication practices and it is the basis upon which future steps to improve lubrication will be made. Therefore, the time spent in conducting a thorough survey is well justified. Since a general knowledge of the design of a machine is the requisite for making any critical analysis of its lubrication requirements, it may be necessary to make frequent reference to machine drawings to clarify points that cannot be determined by an external inspection. When lubrication or other maintenance problems are being encountered on a machine, every effort should be made to inspect the machine when it is opened for repair to determine the points where excessive wear or other trouble is taking place.

### LUBRICANT CONSOLIDATION

For best performance results, buy and use only carefully selected lubricants. As shown by Figure 3, establish a list of lubricant types, which is sufficiently extensive to cover essentially all the lubricant requirements for the entire plant. Each type should have characteristics which makes it particularly suitable for applications under certain operating conditions. A common name or number should be assigned each type for use on lubrication schedules, stores records and the like. The total number of different lubricants required, including the various viscosities and consistencies, may amount to 15 to 20 for a large plant.

The general characteristics of any particular lubricant may be determined from information received from the supplier or from testing a sample of the lubricant to determine its measurable physical and chemical properties. The final selection of a particular lubricant to be used should be made only after a careful observation of the lubricant in one or more typical applications in the plant.

### MASTER LUBRICATION SCHEDULES

After the detailed plant survey has been conducted, the lubricant types established and the necessary consolidation of lubricants effected, the next step is the preparation of the master lubrication schedule as shown by Figure 4.

Lubrication schedules are then printed by the computer and placed in the hands of the personnel who apply the lubri-

3. FINAL SELECTION
  - ... FIELD TESTING
  - ... PAST EXPERIENCE

*Figure 3. Lubricant Consolidation.*

cants for their guidance. Without such schedules there can be much confusion and difference of opinion in the plant as to what should be used or even what is actually being used in the different equipment, especially when there has been a change in either supervision or the operating personnel in the plant. The mere issuing of the lubrication schedule, of course, does not insure compliance.

### Lubrication Notification

Monthly Lubrication Work List, as shown by Figure 5, are printed by the computer. These lists are compiled from the Master Lubrication Schedule for each worker assigned lubrication responsibilities. The notification system is essential for

1. IDENTIFICATION OF EQUIPMENT
2. POINTS OF LUBRICATION
3. LUBRICANTS
4. METHODS
5. FREQUENCIES
6. NAME OF WORKER

*Figure 4. Lubrication Schedules.*

1. PRINTED AND DISTRIBUTED BY 1ST WORKING DAY OF MONTH
2. WORKER NAME AND AREA
3. POINTS OF LUBRICATION
4. LUBRICANT
5. SIGNED AND DATED
7. RETURNED TO SUPERVISOR WHEN COMPLETE

Figure 5. Lubrication Notification Work List.

effective utilization of the lubrication schedule. These monthly work lists are simply memory joggers for the people with lubrication responsibilities. The work lists are also an effective communication link between the worker and his supervisor. The worker is required to note any unusual condition of the machine or lubricants in the machine that was observed when the lubrication job was being performed.

LUBRICANT HANDLING AND STORAGE

The large quantities of lubricants used in the operation of plants make the buying and handling of these materials within the plants an important item from the standpoint of housekeeping, safety and costs, Figure 6.

To obtain the lowest prices, plants purchase their lubricants in the largest quantities consistent with the rate of usage and the capacity of their storage facilities. In the case of fluid lubricants purchased in quantities greater than 6,000 gallons per year, tank truck delivery generally is preferred.

In addition to the price advantage, purchase in bulk eliminates the storage and handling of large numbers of drums

1. MAJOR CONSIDERATIONS

- ... HOUSEKEEPING
- ... SAFETY
- ... COST

2. STORAGE METHODS

- ... PACKAGED CONTAINERS
- ... BULK QUANTITIES

3. RETURNABLE CONTAINERS

Figure 6. Lubricant Handling and Storage.

within the plant, particularly in those cases where the oil is delivered directly to a tank at the point of consumption in the plant.

Good housekeeping can be maintained only if empty drums are returned from the consuming units to the supplier promptly. Most lubricant suppliers charge deposit fees of \$15.00 to \$18.00 for each drum of oil delivered to the consumer. Full credit is given for the return of each undamaged empty drum. Careful management of returnable empty drums can net large annual savings.

For identification of lubricants in handling and applying them throughout the plant, the type name will be stenciled on the lid and side of each drum. The same name appears on the drums as on the lubrication schedules, and the chance of a mistake in application is small.

OIL SAMPLING AND TESTING PROGRAM

The technique of used oil analysis as a preventative and predictive maintenance tool has been used by industry for many years [1]. The prevention of unexpected outages of critical machinery can be avoided or at least kept to a minimum when a program is properly initiated and maintained.

Oils from critical machinery are tested periodically to determine their suitability for continued use, Figure 7.

1. CRITICAL MACHINERY

- ... TURBO MACHINERY
- ... ENGINES
- ... GEARS
- ... OTHERS

2. ADVANTAGES

- ... PREVENTS UNEXPECTED OUTAGES
- ... REDUCE PRODUCTION LOSSES
- ... REDUCE MAINTENANCE COST
- ... LONGER OIL LIFE

3. OIL ANALYSIS

- ... PHYSICAL AND CHEMICAL
- ... WEAR METALS
- ... PRODUCT CONTAMINATION
- ... RECOMMENDATION

Figure 7. Oil Sampling and Testing.

A sample of the oil is withdrawn from the system and several of its characteristics measured in the laboratory. The usual tests conducted to determine the condition of used oils include: (1) viscosity, (2) pH and neutralization number, (3) precipitation, color and odor. There are, however, additional tests that may be conducted for a more detailed evaluation of the used oil. Typical are: (1) metals analysis by atomic absorption or spectographic methods, (2) infrared, (3) X-ray diffraction, gel permeation chromatography etc.

The test results are subsequently reviewed and compared with the new oil specifications. Depending upon the nature or degree of departure from new oil, the laboratory will either approve the lubricant for continued use or recommend the necessary corrective action.

#### EVALUATION OF NEW LUBRICANTS

Since most lubricant manufacturers conduct continuous research to develop lubricants with more desirable combinations of characteristics, it is difficult to state that any particular lubricant is the "best" lubricant. A lubricant that may appear to be the best this year may be surpassed by a newly developed lubricant next year.

For this reason, it is advisable to give consideration from time to time to new lubricants offered by suppliers. Figure 8 shows the considerations that may be taken when new lubricants are evaluated.

First, the specifications of the lubricant may be compared with those of the lubricant you are now using and other available similar lubricants. Specifications furnished by the supplier generally are limited to some of the basic physical properties of the lubricant and are sufficient to indicate its type and something of its composition.

The specifications and test data serve as good means for screening lubricants, but they do not give an absolute measure of the all-around performance of a lubricant in a given application. This can be determined only by observing its performance in actual service as closely as is practical.

Price, of course, is also a factor in the purchase of lubricants. It must be certain, however, that satisfactory performance has been established before price becomes the deciding factor in procurement. A sacrifice in performance can often

1. MANUFACTURERS CONTINUOUSLY UPDATE
2. COMPARE SPECIFICATIONS
3. DETAILED LABORATORY ANALYSIS
  - ... ADDITIVES
  - ... INHIBITORS
4. FIELD TEST
5. PRICE

Figure 8. Evaluation of New Lubricants.

make a seemingly low priced lubricant actually become a very expensive commodity. Also, purchase of the highest priced lubricant gives no assurance of superior performance.

#### LUBRICATION TRAINING

Lubrication training, Figure 9, is as important as any other training programs for plant personnel. The increased skills and knowledge of the people responsible for the actual application of lubricants can substantially increase reliability of costly production equipment. In addition, trained operating and maintenance personnel will be more alert to recognize symptoms of equipment malfunction and report conditions before the equipment actually fails.

The prevention of unscheduled outages can reduce production losses and minimize maintenance costs, especially when catastrophic failures are prevented.

Lubrication training of plant personnel includes instructions on basic principles of lubrication, the computer assisted scheduling and notification program, lubrication procedures and centralized lubrication systems.

#### LUBRICATION METHODS AND PROCEDURES

A highly rewarding phase of any lubrication program in most plants today is the adoption of improved methods for applying lubricants.

Many oil mist and centralized systems have been installed and in almost every case outstanding improvement in lubrication has resulted with the attendant increased life of the machinery and with appreciable overall savings. In initiating such a program in a plant, it is important to keep records showing maintenance costs before and after installation of the new system to convince management of the value of continuing with this type of improvement.

An essential factor in a program of applying centralized lubrication systems is the training of men who will operate this equipment. These same men should have the responsibility of inspecting and maintaining the systems in proper operating conditions.

Figure 10 lists some of the more crucial methods and procedures that have been developed into very effective preventative maintenance tools with improved machinery reliability: constant level oilers, oil lubricated motors, grease lubricated motors, bearing labyrinth purge, reservoir purge and vent system, gear coupling lubrication and oil mist lubrication.

##### *Constant Level Oilers*

The oil in machinery equipped with constant level oilers as shown in Figures 11 and 12 must be routinely *inspected visually* to determine the condition of the working oil. The

1. INCREASE SKILLS AND KNOWLEDGE
2. INCREASED MACHINE RELIABILITY
3. RECOGNIZE TROUBLE AREAS
4. PREVENT CATASTROPHIC FAILURES

Figure 9. Lubrication Training.

1. CONSTANT LEVEL OILERS
  - ... OIL
  - ... GREASE
3. CIRCULATING OIL SYSTEMS
  - ... BEARING LABYRINTH PURGE
  - ... RESERVOIR PURGE AND VENTS
4. GEAR COUPLING LUBRICATION
5. OIL MIST LUBRICATION

Figure 10. Lubrication Methods and Procedures.

frequency of the visual inspection can vary from *one month* to *three months*, depending on the severity of service.

The operators must be continually aware that all oiler bowls contain oil. The frequency for checking these may vary from each shift to once weekly, depending on experience with each machine.

The definition of "visual" is to drain 2 ounces of oil from the bottom of the bearing and observe:

1. Oil appearance — it should be normal color. Dark color change normally indicates the oil has oxidized. Change the oil if it is discolored.
2. Check for contaminants. Look for water, product or dirt. Change the oil if it is contaminated.
3. Verify that oil will flow into bearing after the 2 ounce bottom sample has been drawn. Air bubbles should rise from the bottom of the oiler bowl as oil flows into the bearing. If no air bubbles are observed, this indicates:
  - a. The machine may be overfilled. Drain excess oil until air bubbles begin to rise in bowl.
  - b. The connecting pipe nipple between the oiler and bearing may be plugged with sludge. Remove the pipe nipple and oiler lower bowl and clean.
  - c. The bearing housing vent may be plugged creating an unequal pressure between the bearing and the oiler.

Figure 12 illustrates a constant oiler with a balance line between the bearing housing and the oiler lower bowl. This type installation is required for bearing housings having an excessive back pressure or vacuum. A constant level can be

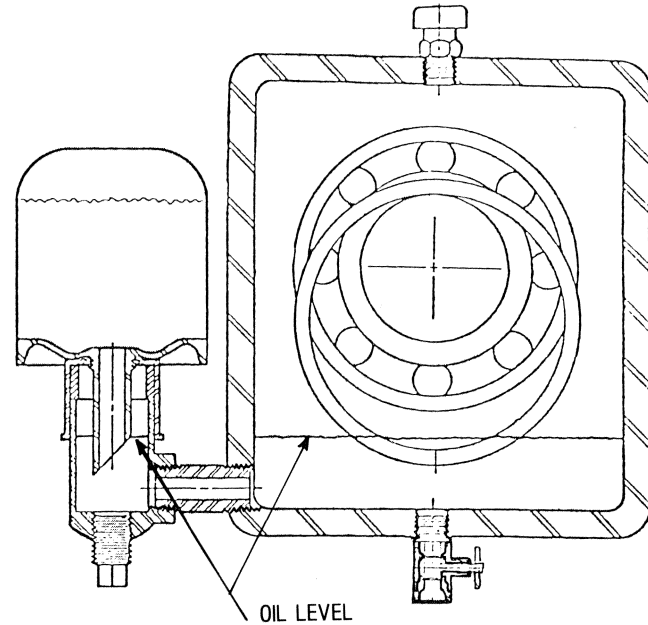
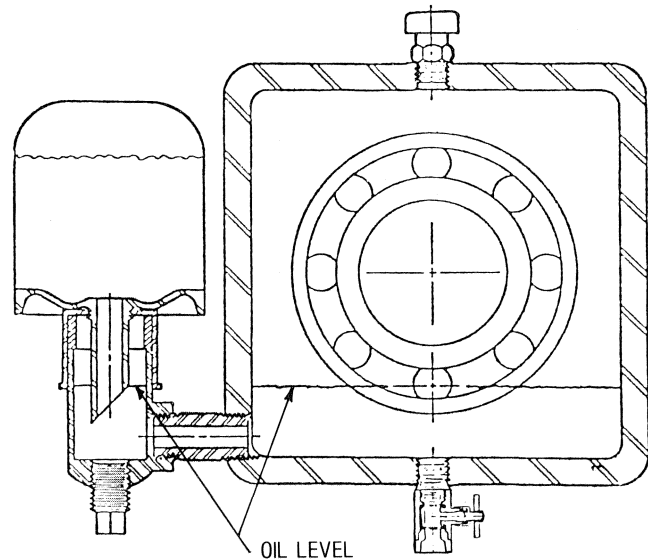

Figure 11. Constant Level Oiler, Conventional Design.

maintained in spite of pressure or vacuum in the housing as the equalizing tube provides static balance of pressure between the bearing housing and oiler lower bowl.

#### Oil Lubricated Electric Motors

Oil lubricated motors, see Figure 13, are generally large frame designs. These motors may have oil supplied from a console common with the driven equipment, an independent console just for the motor or each bearing housing with its own oil supply. The first and second types are preferred since the oil condition in all consoles is monitored by oil analysis. The latter type requires regular attention to obtain maximum bearing life.

Motors with each bearing having a captive oil supply are checked weekly for oil level. At three month intervals the oil in each bearing is checked visually. A sample is drawn from the

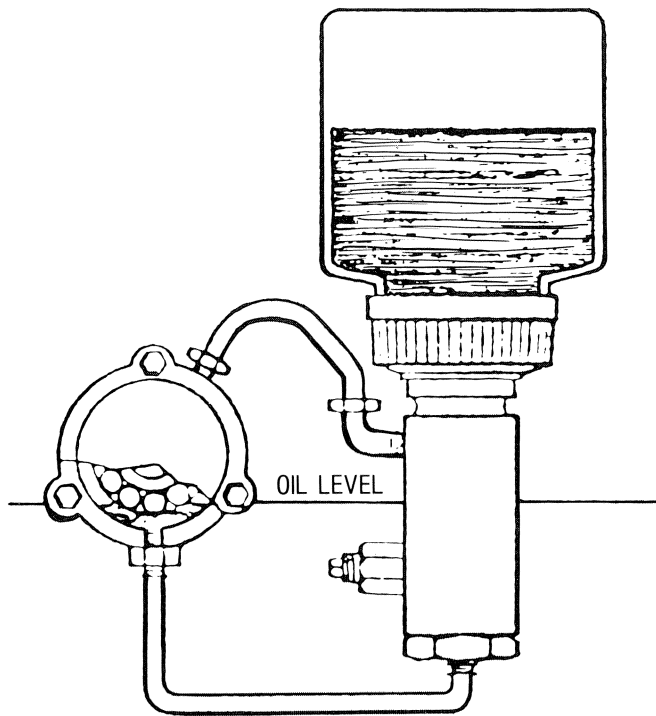

Figure 12. Constant Level Oiler, With Vent Line.

bottom drain into a glass container. The sample is *visually* checked for appearance including moisture, dirt or other discoloration. The oil will be changed if contaminated. This type motor may be equipped with constant level oilers and in that case the procedure for checking constant level oilers is applied.

*Grease Lubrication of Electric Motors*

Electric motors are re-lubricated at regular intervals based on size, speed, duty and environment.

- 1. LARGE FRAME DESIGNS
- 2. METHODS OF LUBRICATION
  - ... CONSOLE - COMMON WITH DRIVEN
  - ... CONSOLE - MOTOR ONLY
  - ... BEARING HOUSINGS - CAPTIVE SUPPLY
- 3. CAPTIVE OIL SUPPLY
  - ... WEEKLY - CHECK OIL LEVEL
  - ... PERIODIC - VISUAL
  - ... CHANGE CONTAMINATED OIL

Figure 13. Oil Lubricated Electric Motors.

The lubrication schedule for specific motors is shown on the computerized Programmed Lubrication Schedule.

Grease-lubricated electric motor types are:

1. Motors with grease inlet and outlet ports on the same side of the bearings, see Figure 14, commonly referred to as conventional design.
2. Motors with grease inlet and outlet ports on opposite sides of the bearings, see Figure 15, commonly referred to as cross flow design.

Each of these motor types require different procedures of lubrication. The essential difference is the motor with inlet and outlet grease ports on the same side of the bearing *must be lubricated with motor stopped*. The motor with inlet and outlet grease ports on the opposite sides of the bearings *must be lubricated with the motor running*.

The following procedures were developed by our Lubrication Technical Services Group after lengthy studies of the various motors in use since 1960.

Motors with Conventional Housing Design

1. Stop motor.
2. Inboard bearing (coupling end):
  - a. Remove grease inlet plug or fitting.
  - b. Remove grease outlet plug. Some motor designs, certain Reliance types, do not have grease relief ports. These motors relieve grease pressure around the shaft.
  - c. Remove hardened grease from the inlet and outlet ports with a clean probe.

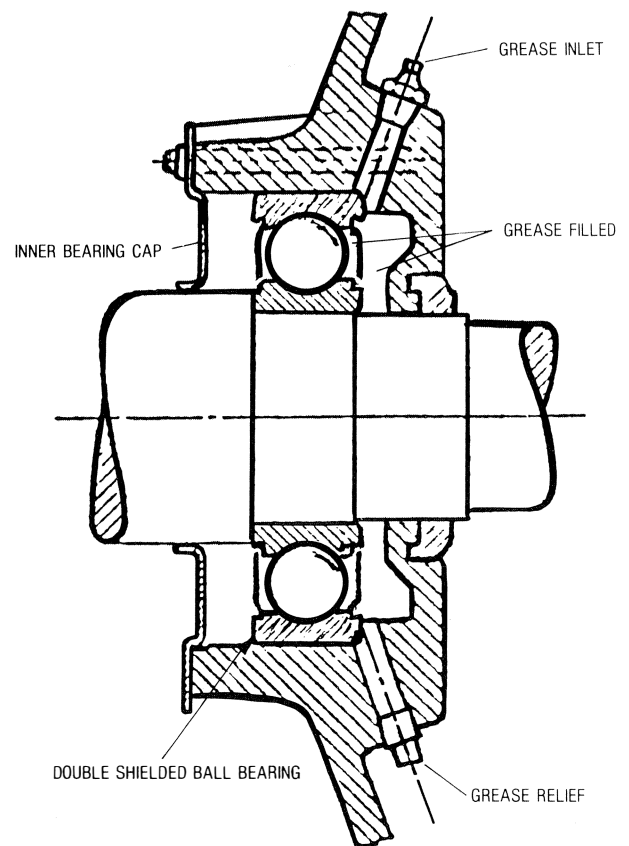

Figure 14. Grease Lubrication Motor With Conventional Housing.



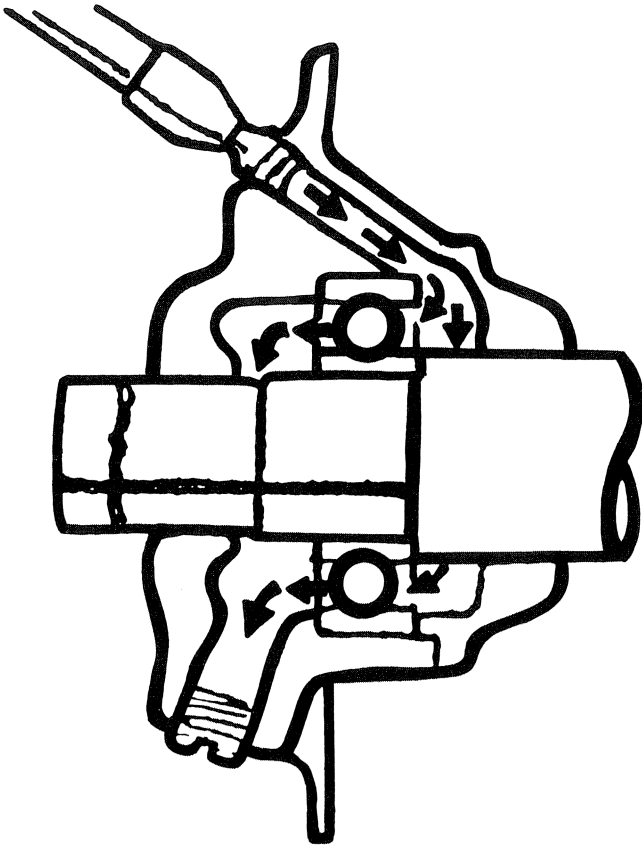

Figure 15. Grease Lubricated Motor With Cross Flow Housing.

- d. Inspect the grease removed from the inlet port. If rust or other abrasives are observed, **DO NOT GREASE THE BEARING**. Tag motor for overhaul.
  - e. Leave probe inserted in the outlet port. Position probe depth equivalent to the bottom balls of the bearing.
  - f. Replace grease fitting and add grease slowly with a hand operated grease gun. *Count strokes of gun* as grease is added.
  - g. Stop pumping when the probe in the outlet port begins to move or when grease appears around the shaft on motors without a grease outlet port. This is an indication the grease cavity contains an adequate quantity of grease.
3. Outboard bearing (fan end):
    - a. Follow inboard bearing procedure provided the housing is equipped with an outlet grease port and provided the outlet plug is accessible.
    - b. If grease outlet port is not accessible or if the housing is not equipped with an outlet port, add 2/3 of the amount of grease required for the inboard bearing.
  4. Leave grease outlet ports open, **DO NOT REPLACE** the plugs. Excess grease will be expelled through the port.
  5. Refer to Figure 14 for an illustration of a typical bearing housing designed with the inlet and outlet ports on the same side of the bearing.

#### Motors With Cross Flow Housing Design

1. Start motor! Allow to operate until normal motor temperature is obtained.

2. Inboard bearing (coupling end):
  - a. Remove grease inlet plug or fitting.
  - b. Remove outlet plug. Some motor designs are equipped with excess grease cups located directly below the bearing. Remove the cups and clean out the old grease.
  - c. Remove hardened grease from the inlet and outlet ports with a clean probe.
  - d. Inspect the grease removed from the inlet port. If rust or other abrasives are observed, **DO NOT GREASE THE BEARING**. Tag motor for overhaul.
  - e. Bearing housings with outlet ports:
    - (1) Insert probe in the outlet port to a depth equivalent to the bottom balls of the bearing.
    - (2) Replace grease fitting and add grease slowly with a hand gun. *Count strokes of gun* as grease is added.
    - (3) Stop pumping when the probe in the outlet port begins to move. This is an indication the grease cavity contains an adequate quantity of grease.
  - f. Bearing housings with excess grease cups:
    - (1) Replace grease fitting and add grease slowly with a hand gun. *Count strokes of gun* as grease is added.
    - (2) Stop pumping when grease appears in the excess grease cup. This indicates the grease cavity contains an adequate quantity of grease.
3. Outboard bearing (fan end):
  - a. Follow inboard bearing procedure provided the outlet grease ports or excess grease cups are accessible.
  - b. If grease outlet port or excess grease cup is not accessible, add 2/3 of the amount of grease required for the inboard bearing.
4. Leave grease outlet ports open — **DO NOT REPLACE** the plugs. Excess grease will be expelled through the port.
5. If bearings are equipped with excess grease cups, replace the cups. Excess grease will expel into the cups.
6. Refer to Figure 15 for an illustration of a typical bearing housing designed with the inlet and outlet grease ports on opposite sides of the bearing.

#### Bearing Labyrinth Purge

Atmospheric water condensation in turbomachinery oil systems can be a serious detriment. Every reasonable effort must be made to prevent this source of contamination.

Experience has proven that circulating oil systems can be kept free of water by modifying the bearing labyrinth to provide an inert gas or dry air purge on each atmospheric shaft seal on each bearing. Figure 16 illustrates a typical bearing labyrinth purge system that has been successfully used to prevent water contamination.

Figure 17 illustrates the modification procedure. A 1/8" diameter hole is drilled through the bearing cap end wall to intersect the labyrinth. A 1/4" metal tubing from the purge hole in the bearing cap shall be connected to a O-50SCFH rotometer. Adjust the flow rate of the purge gas on each seal to 10SCFH with the rotometer. Subsequent increased flow may be required depending on condition of seal to keep the oil water free.

#### Reservoir Purge and Vent System

The vapor space in the oil reservoir shall also be purged to keep the system water free. Experience has proven 25-50SCFH purge on the reservoir combined with the bearing labyrinth purge is required to maintain a water free system.

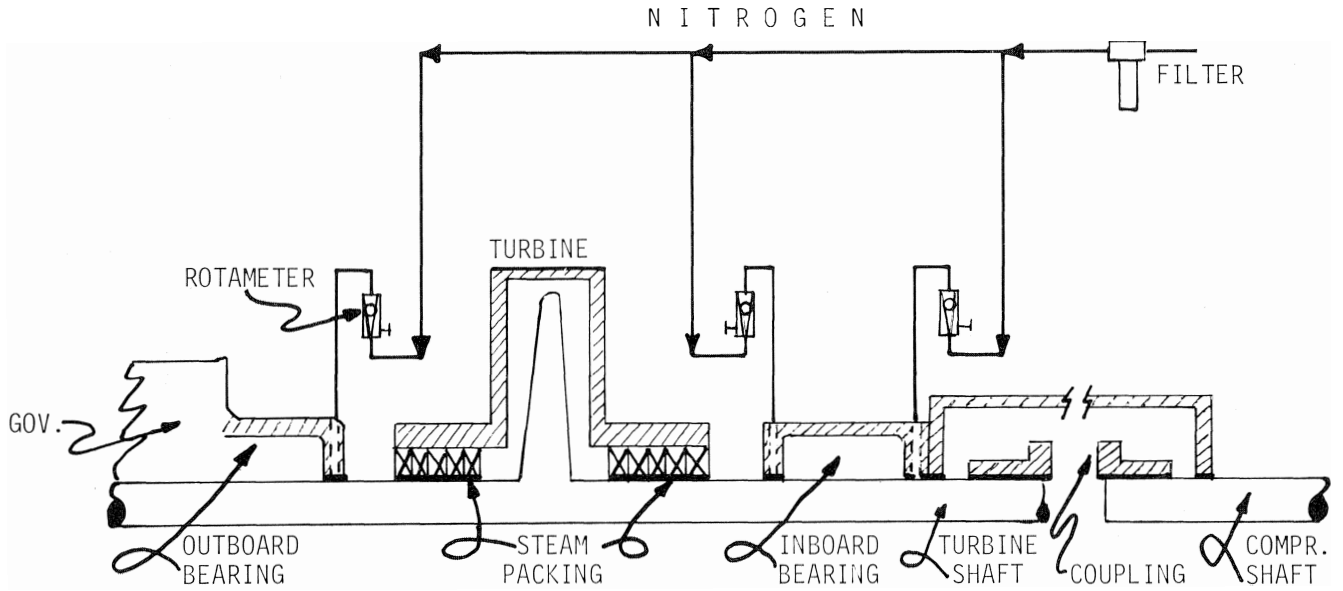

Figure 16. Typical Bearing Labyrinth Purge System.

Check the reservoir vent. It must be located in the top or in the end or side near the top of the reservoir. It must be free of baffles that would collect and return condensate to the reservoir. Keep the length as short as possible to provide minimum surface on which water vapors could condense. When it is necessary to run the vent up and away from the reservoir, a water trap should be provided as close to the reservoir as possible to prevent condensed water formed in the vent stack from entering the oil system.

GEAR COUPLING LUBRICATION

The gear coupling is one of the most critical components in a turbo machine and requires special consideration from the standpoint of lubrication and attention [2].

There are two basic methods of gear coupling lubrication: batch and continuous flow. In the batch method the coupling is either filled with grease or oil; the continuous flow uses only oil, and almost exclusively light oil from the circulating oil system [3].

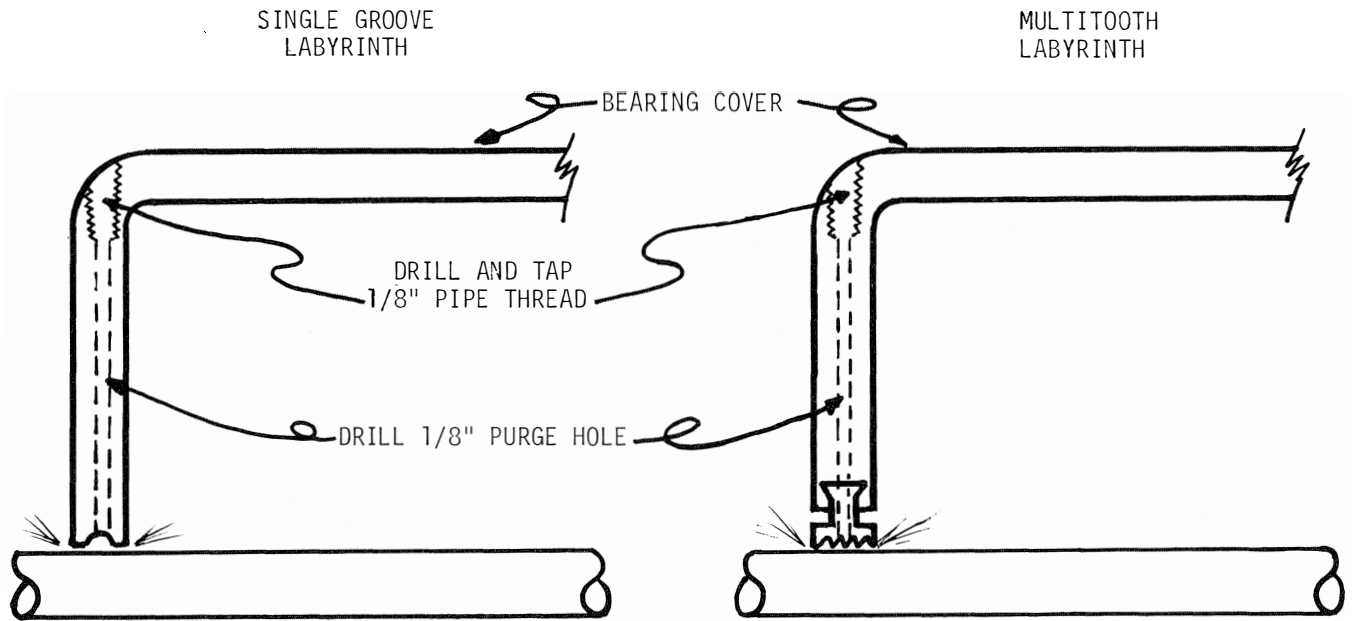

CAUTION: Do not allow drill to break into bearing housing. Purge holes must intersect center of labyrinth.

Figure 17. Typical Bearing Seal Purge.

The grease filled coupling requires special quality grease. The importance of selecting the best quality grease cannot be overemphasized. A good coupling grease must prevent wear of the mating teeth in a sliding load environment and resist separation at high speeds. It is not uncommon, Figure 18, for centrifugal forces on the grease in the coupling to exceed 8000 G's [4].

Testing of many greases in a high speed laboratory centrifuge in our laboratory and other laboratories [1, 4, 5] prove there is a decided difference between good quality grease and inferior quality grease for coupling service. Testing also shows separation of the oil and soap is a function of G level and time. In other words, oil separation can occur at a lower centrifugal force if given enough time. The characteristics of grease that allow the grease to resist separation are [4]: (a) high viscosity oil, Figure 19, (b) low soap content, (c) soap thickener and base oil as near the same density as possible.

Recently a number of greases were tested in our laboratory for separation characteristics in a Sharples high speed centrifuge and for wear resistance on a Shell 4 Ball Extreme Pressure Tester. It was found, Figure 20, that Grease B exceeded all other greases tested in separation characteristics. Zero separation was recorded at all speeds up to and including 60,000 "G's". Greases A, C and D were rated poor in separation characteristics at all speeds tested.

Figure 21 illustrates how these four greases performed on the Shell 4 Ball Extreme Pressure Tester in comparison with a typical Extreme Pressure gear oil. Based on this data, Greases A and B should provide excellent wear protection in severely loaded service. Based on these test results, Grease B is currently our recommendation for all grease lubricated couplings for all speed and load ranges.

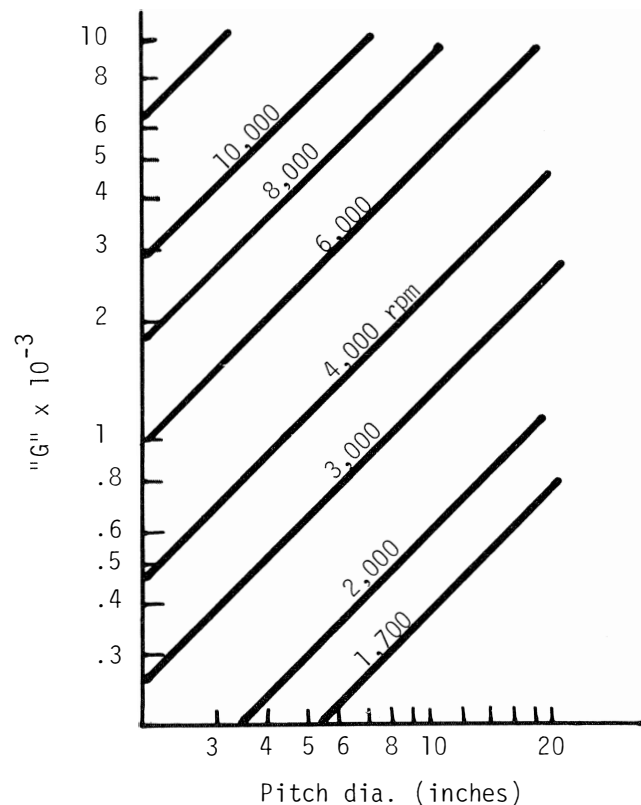

Figure 18. Centrifugal Forces in Couplings.

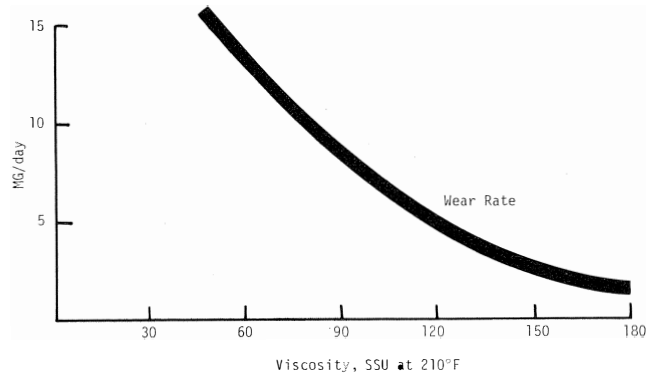

Figure 19. Effects of Lubricant Viscosity on Coupling Wear.

GREASE	"G" LEVEL		
	60,000 2.5 hr	32,000 6 hr	9,700 6 hr
GREASE "A"	53	35	—
GREASE "B"	0	0	0
GREASE "C"	79	75	40
GREASE "D"	51	—	—

Figure 20. Centrifugal Separation - % Oil Extracted.

GREASE	KILOGRAM LOAD PASSED
GREASE "A"	80
GREASE "B"	90
GREASE "C"	50
GREASE "D"	20
TYPICAL E.P. 140 OIL	90

Figure 21. Shell 4 Ball Test — 1 Minute Wear Load.

Oil Mist Lubrication

The oil mist principle of lubrication was developed in the 1930's by a European bearing manufacturer to solve high speed bearing lubrication problems where neither grease nor circulating oil methods were successful. In the mid-40's, a U.S.A. manufacturer acquired the rights to develop and introduce the oil mist method of lubrication to U.S. industry. Since then it has been successfully used to lubricate widely diverse types of

machinery such as pumps, ball and roller bearings, bushings, ways, guides and gears.

Principle of Operation

The oil mist method of lubrication is a centralized lubrication system which uses the energy of compressed air to continuously atomize oil and convey it through low pressure piping to multiple points of lubrication.

A schematic of a typical oil mist lubrication system is shown in Figure 22. The principle elements are: a supply of air, oil, mist generator, air heater, oil heater, pressure gauge, hi-lo pressure switch, low level switch, and mist fittings.

Oil Mist Generator

The generator shown in Figure 23 is the heart of the oil mist system. It atomizes oil in a manner similar to a carburetor atomizing fuel for the automobile engine. Both devices use a venturi or vortex to produce a mist. Compressed air is blown through the venturi or vortex and liquid oil is drawn in by the suction that is created. Oil is mechanically fractured into tiny droplets and particles by the high velocity air stream. Downstream, the mixture impinges against baffles where large oil droplets, that would not transport readily, are coalesced and returned to the reservoir. The remaining particles are finely divided, ranging in size from 1 - 4 microns diameter. They are capable of being transported as aerosols through hundreds of feet of piping to points of lubrication. The concentration of oil in the mixture delivered by the generator is on the order of 0.004 pound per pound of air. This is equal to a mist density of .2 cubic inches of oil per hour per cfm flow. An 10 cfm generator will use 1.6 pints of oil per day and can lubricate up to 40 chemical pumps.

Manifolding and Piping

The maximum velocity of the distribution piping is 24 feet per second. The main header should be fabricated with 2" pipe

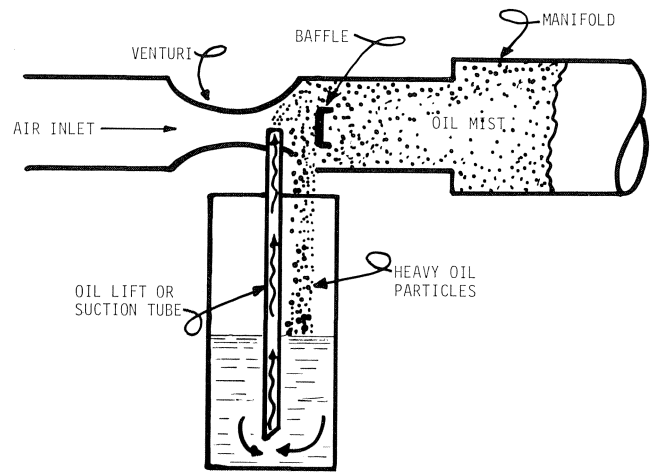

Figure 23. Principle of Oil Mist Generation.

and can be extended up to 300 feet from the generator. Secondary or branch lines should be constructed with 3/4" pipe for distances up to 75 feet, supplying mist to a maximum of five pumps.

Mist Fittings

Three different designs of discharge fittings or reclassifiers that meter the amount of mist are illustrated in Figure 24. They differ in the degree of coalescence from essentially none, for the pure mist, to essentially complete coalescence for the condensing fitting. The pure mist and spray fittings have some of the features of the two extremes.

The most commonly used fitting in the Texas Division is the pure mist. This application is primarily used to lubricate

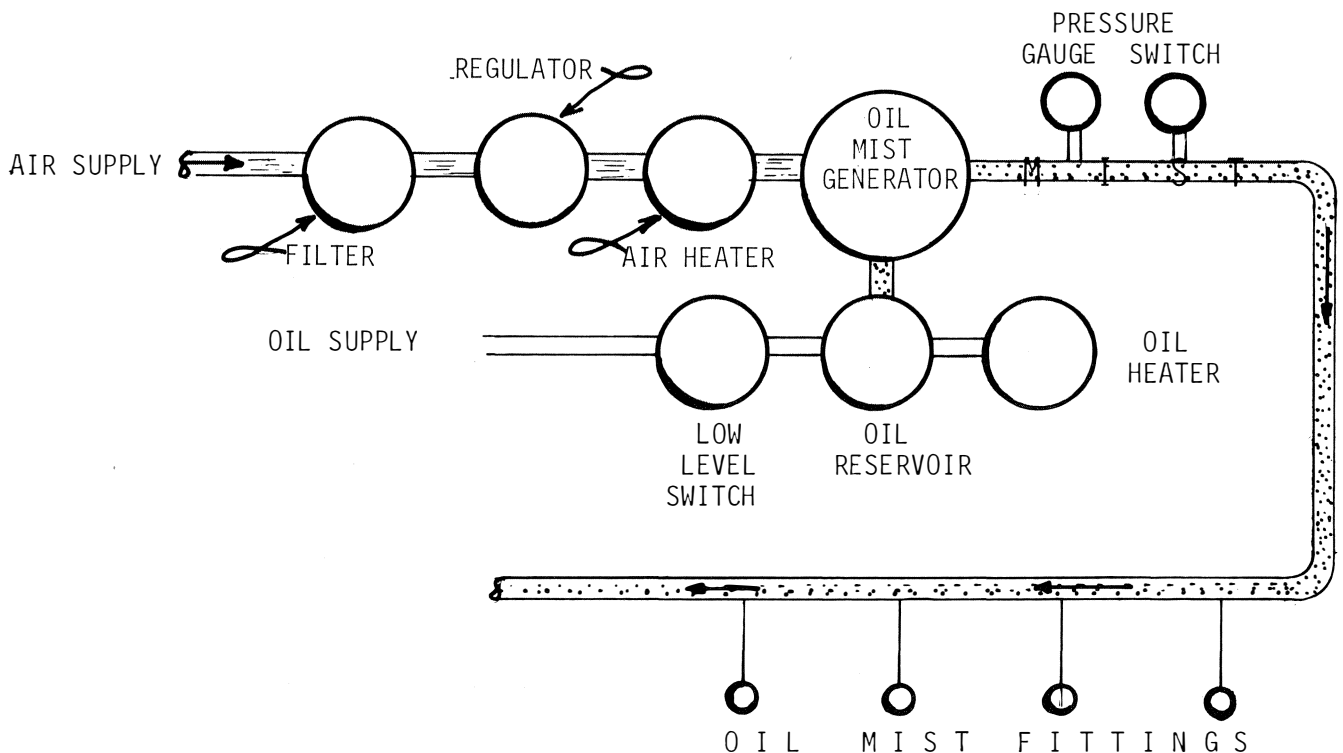

Figure 22. Oil Mist Schematic.

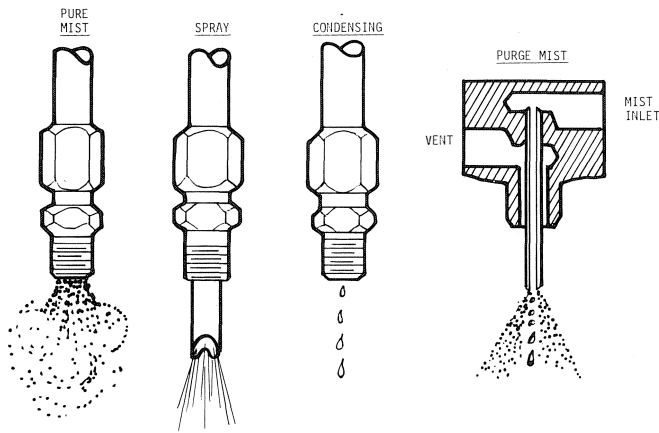

Figure 24. Application Fittings.

centrifugal pumps and electric motors equipped with ball bearings. This type fitting is used when the rotating speed of the bearing is a minimum of 200 linear feet per minute. The large amount of moving surfaces of a ball bearing produces internal turbulence to cause impingement and collection of oil upon the surfaces of the ball bearing.

The *spray fitting* discharges both liquid droplets and a mist with sufficient directional control to allow targeting. Generally, spray fittings are applied to chains, rollers, rolling element bearings and gears.

*Condensing fittings* produce oil droplets. These fittings have internal restrictions that create mist velocities that are necessary to attain coalescence. They are typically applied to slow speed plain bearings, ways, slides and guides.

Other System Components

In addition to the mist generator, manifold and mist fittings, a complete commercial oil mist system includes: a supply of compressed air, a filter, separator, a pressure regulator, air heater, oil reservoir, oil heater, pressure gauge and alarms. The *air supply* is piped through an *air heater* to standardize the misting conditions through-out the year. The external oil heater with a surface mounted thermostat maintains an oil temperature of approximately 100°F in the reservoir.

Heated air and oil allows the generator to produce a uniform mist density the year round. The *filter-separator* traps dirt, scale and water that may be in the incoming air. The *pressure regulator* controls the overall system manifold pressure. Generally, the oil mist system is designed to operate at 20 inches of water pressure. The manifold *pressure gauge* indicates the mist pressure within the manifold. The manifold *pressure switch* is a dual range type used to signal low and high manifold mist pressure. Generally, it is set to alarm at 16 inches water pressure and also set to alarm at 24 inches water pressure. The *Low Oil Level Switch* signals when the oil level in the reservoir drops to ¼ full.

Typical Oil Mist Installation

Figure 25 illustrates a typical oil mist installation for chemical pumps and electric motors. The console houses the generator, air and oil heaters, pressure switch, pressure gauges, low level alarm, control and alarm relays. The main line manifold conveys oil mist to points of lubrication. These systems are available to meet the requirements for Electrical Hazards Class I, Group D, Division 2. Also, they are available in weather-proof cabinets equipped with non-hazardous electrical components. Figure 25 also shows the various arrange-

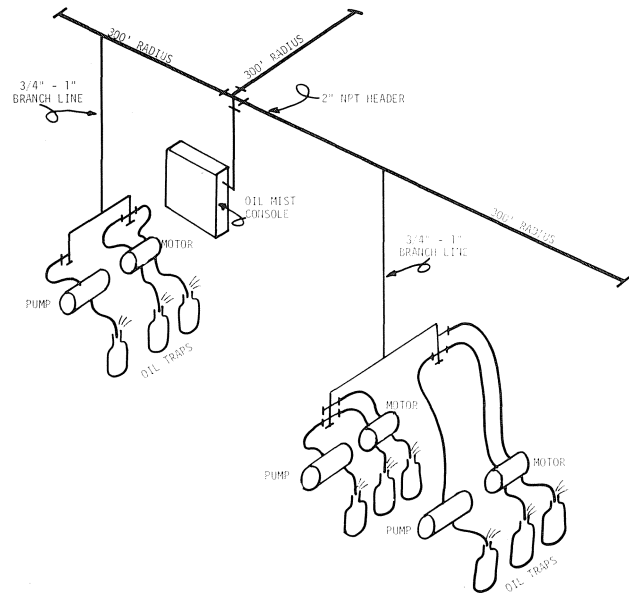

Figure 25. Typical Oil Mist System.

ment methods of routing an oil mist manifold. When the piping layout is made, the possibility of *trapping liquid oil must be avoided*. It is recommended that the piping system be oriented so that the first 10 to 20 feet of the main manifold is sloped slightly downward back to the mist generator. Feeder and branch connections are made to the under side of the manifold pipe in order to eliminate the collection of liquid oil in the line.

Benefits of Oil Mist Lubrication

Oil mist lubrication has the well known advantages attributed to centralized lubrication as well as some unique features: Figure 26 - (1) longer machine life, (2) clean oil continuously, (3) positive housing pressure, (4) maximum rust and corrosion protection, (5) minimum lubricant consumption, (6) lower operating cost and (7) less down time.

1. LONGER MACHINE LIFE
2. CLEAN OIL CONTINUOUSLY
3. POSITIVE HOUSING PRESSURE
4. MAXIMUM RUST PROTECTION
5. MINIMUM OIL CONSUMPTION
6. LOWER OPERATING COST
7. LESS DOWN TIME

Figure 26. Benefits of Oil Mist Lubrication.

## CONCLUSION

The author has attempted to place lubrication of plant equipment in the correct perspective with maintenance and production. Experience has proven that unless *REQUIRED* lubrication is continuously provided, the most advanced machine designs and latest process technology are sure to fail. Planned lubrication programs followed daily, including an oil sampling and testing program, is the first step required to sustaining production with reduced equipment outages and lower maintenance costs. Other important factors are: (1) improved handling and storage of lubricants, (2) continuous evaluation of new lube products, (3) effective lubrication training programs and (4) the application of the latest lubrication methods and procedures.

Many of the lubrication procedures discussed in this paper were the direct results of lubrication problem studies. It is important to question each mechanical failure. Only a thorough investigation will reveal the true cause, and when the cause is recognized the solution is generally obvious. Lubrication causes are many times very easily corrected. Perhaps the solution is as simple as replacing the wrong lubricant with the correct type or changing the frequency. More complicated so-

lutions may involve lengthy studies that produce new methods and procedures not yet generally known in the industry. Unless the lubrication of plant equipment is continuously updated some of the latest process technology and advanced machine design may be in jeopardy due to dependence on obsolete lubrication systems, procedures and lubricants.

## REFERENCES

1. J. E. Steenbergen, "Comprehensive Lube Oil Analysis Program: A Cost Effective Preventative Maintenance Tool." ASLE 33 Annual Meeting, April 17-20, 1978.
2. A. M. Clapp, "Fundamentals of Lubrication Relating to Operation and Maintenance of Turbomachinery." First Turbomachinery Symposium, Oct., 1972.
3. Mike Calistrat, "Gear Coupling Lubrication." ASLE Annual Meeting, April 1974.
4. Mike Calistrat, "Extended Gear Coupling Life." *Hydrocarbon Processing*, January, 1978.
5. Mike Calistrat, "Grease Separation Under Centrifugal Force." ASME July, 1976.