

# HYDRAULICALLY FITTED HUBS, THEORY AND PRACTICE

by

**Michael M. Calistrat**

Manager, Mechanical Section

Research & Development Department

Koppers Company, Inc.

Engineered Metal Products Group

Baltimore, Maryland

*Michael M. Calistrat is manager of the Mechanical Section in the Research and Development Department of the Engineered Metal Products Group of Koppers Company, Inc. He has made important contributions in the development of new power transmission products, and holds 14 U.S. patents. Mr. Calistrat has published a number of papers related to power transmission problems, and has written chapters for the Wear Manual, Lubrication Handbook, and Plant Engineering Handbook. He is the chairman of the Shaft Couplings and Clutches Committee of ASME, chairman of an ASTM committee, and chairman of the forthcoming Fourth International Power Transmission and Gearing Conference. Mr. Calistrat received his M.S. degree in Mechanical Engineering from the University of Bucharest (Rumania) in 1951.*



second part gives the rules that have to be followed for a safe installation and removal of the hub, and illustrations showing various methods in use.

## INTRODUCTION

Assembling a cylindrical body over a shaft by an interference fit is a very old art. To the author's knowledge it was first used when steel bands were fitted over wooden wheels on carts and coaches. The shrink-fit relies on the high pressure developed when the heated outer body is allowed to cool over an inner body. The same principle was, and still is, used in railroad wheels, where a high strength steel band is fitted over a cast wheel, whether iron or aluminum. The problem of dismantling these bands did not exist. When the band wears thin, it is cut, discarded and replaced.

More modern times saw the advent of the turbine, and turbine wheels were also shrunk onto the shaft. In the early 1940's, a novel idea was introduced by SKF in Sweden: build hydraulic pressure between the outer body and the shaft in order to facilitate removal and installation.

## ABSTRACT

The transmission of torque from a shaft to a hub can be efficiently accomplished through the use of friction. The advantages of this system over a keyed connection are: (1) the significant reduction of stress concentrations in the shafts and hubs, (2) an increase in the torque that can be transmitted, and (3) the ease of hub removal. The disadvantages of this system are: (1) it requires more care at installation, and (2) it can generate high shaft stresses if misused.

The theory of transmission of torque through the use of friction is relatively simple. A hub having a bore slightly smaller than the shaft on which it will be installed is expanded radially either through heating or through hydraulic pressure. Sufficiently expanded, the hub can slide on the shaft and then is allowed to resume its original diameter; however, the shaft prevents this from happening. In the process, a high contact pressure is created at the interface. It is this pressure, the contact area, and the coefficient of friction that generate the tangential force which permits the torque transmission. The contact pressure at the interface also generates high stresses in the parts. These stresses must be carefully calculated in order to avoid immediate failure of the hubs, or fatigue failure of the shafts.

The practice of hydraulic installation and removal is simple if a few rules are religiously followed. The most important ones are: (1) very good contact pattern at the interface, (2) cleanliness of the parts and oil, (3) accurate measurements of pressures and motion, and (4) observance of safety rules.

This paper gives the formulae necessary for the calculation of the torque that can be transmitted through an interference fit, and for the calculation of the generated stresses. The

## THEORY

The author claims no new insights into the theory of interference fitted hubs, or to the theoretical aspect of hydraulic expansion of the hubs during installation and removal. But many a time the question was heard: "How much interference is needed for hydraulically fitted hubs?" This question cannot be answered until some other questions are answered first. There are many variables that must be known in order to engineer such a system. For instance: what is the shaft diameter, the torque, the speed, and also what is the strength of the hub and shaft material and what are the hub's length and outside diameter?

In order to understand why all this data is needed, a short review of torque transmission through interference fits is given below. For the curious mind, the author recommends the reading of the literature cited at the end of the paper.

The torque that *can* be transmitted (see Figure 1) is the product of the contact area, the contact pressure, the coefficient of friction, and the radius of the shaft,

$$T = A p \mu d/2 \text{ (in./lb.)} \quad (1)$$

Let us analyze each of these factors.

### 1. Contact area

$$A = \pi d L \text{ (inch}^2\text{)} \quad (2)$$

Although it seems that nothing can be added, the question exists: should one use the effective area or the theoretical

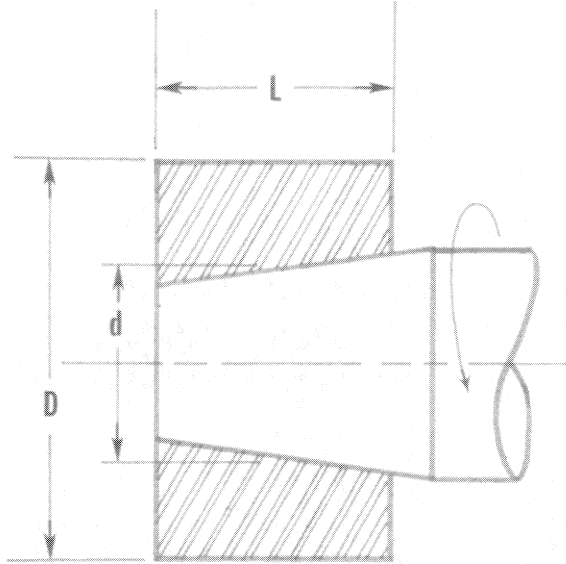

Figure 1. Basic Configuration of an Interference Fitted Hub.

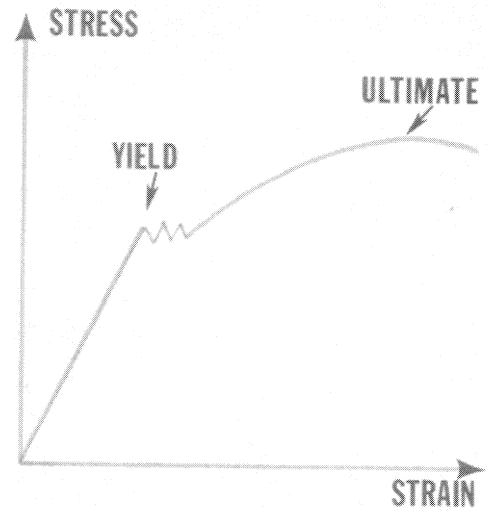

Figure 2. Typical Stress - Strain Curve for Steel.

area? The theoretical area, as expressed in equation (2), does not account for the "O" rings and oil distribution grooves, for the hub overhang, or for the imperfect contact between the bore and the shaft. However, any reduction in area (within reason) results in an equivalent increase in the contact pressure, hence the total length of the hub bore should be used in the calculations.

## 2. Contact pressure [1].

$$p = i E (D^2 - d^2)/2D^2 \text{ (lb./in.}^2\text{)} \quad (3)$$

where  $i$  = interference rate (in./in.)  
(diametral interference/shaft diameter)

$E$  = modulus of elasticity; for steel  $30 \times 10^6$  lb./in.<sup>2</sup>

(Note: Throughout this paper interference *rate* is used exclusively.)

One can already see that while little can be done to increase the contact area, the contact pressure is directly proportional to the amount of interference. The amount of interference that can be used is limited by two factors: difficulty of removal, and stresses in the hub. The difficulty of removal lies mainly in the limitations of the hydraulic systems to generate enough pressure to expand the hub; the stresses in the hub limit the amount of interference because of the particular relationship between the stress and strain of steel alloys.

From Figure 2 it can be seen that the forces generated by the interference are proportional to the amount of interference only in the elastic zone, as determined by the yield point. A further increase in interference (strain) has a minimum effect on the forces on the system, but brings the hub material dangerously close to failure. Here is, then, the first reason one cannot answer directly to the question: "How much interference should be used?" One must first know the yield strength of the materials used.

The maximum combined stress (compressive plus tensile) occurs at the hub bore, and is expressed as:

$$\sigma = \frac{p\sqrt{3 + c^4}}{1 - c^2} \text{ (lb./in.}^2\text{)} \quad (4)$$

where  $c = d/D$ . (5)

Studies performed by SKF indicated that the maximum acceptable stress to yield stress ratio ( $K$ ) is also a function of  $d/D$ , and its value can be found in Figure 3.

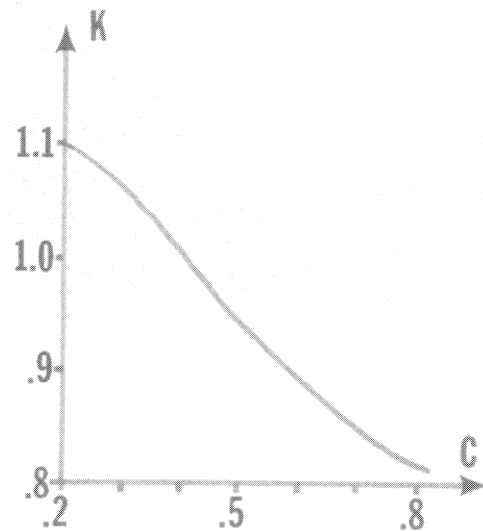

Figure 3. Allowable Stress Factor for Hubs.

It is interesting to note that the yield point may even be exceeded in the case of a thick-walled hub, in which case the permanent deformation which occurs only in the immediate vicinity of the bore has no influence on the design of the system.

What happens to the interference when the hub is installed? Before installation, the bore is smaller than the shaft; after installation, they have the same dimension. Due to the pressure at the interface the hub bore grows, and the shaft shrinks. As shown in the Appendix, the hub's expansion is about four times larger than the shaft's shrinkage. As the bore grows, so does the outer diameter of the hub, but to a lesser extent. This is why coupling manufacturers always leave a clearance in the pilot diameters, otherwise the other coupling components could not be installed after the hub is mounted on the shaft.

### 3. Coefficient of friction

If the two mating surfaces could indeed make perfect contact, there would be total molecular adhesion and the two parts would fuse together. Molecular layers of oxides, gases and lubricants which are practically always present, hinder, to a greater or lesser degree, the direct contact between surfaces. This is why wide variations in the value of the coefficient of friction occur, even when the same components are mounted under the same conditions, but on different occasions. Practical values for coefficients of friction that have been established experimentally are [2]:

- a. Hydraulically installed hubs, using mineral oil  
 $\mu = .12$
- b. Hydraulically installed hubs, using glycerine  
 $\mu = .18$
- c. Heat shrunk hubs (300°C), normal cleanliness  
 $\mu = .14$
- d. Heat shrunk hubs (300°C), very clean parts  
 $\mu = .20$

The above values (a,b,c) assume that a solvent was used to clean the components, which are free of impurities, and have a surface finish of 32 RMS microinches, or better. A high coefficient of friction with glycerine seems odd considering its excellent lubrication properties. However, mineral oils are more likely to be trapped at the interface, a fact that contributes to the low coefficient of friction in this case.

Using the above formulae, one can now determine the interference required to transmit a given torque. The author has to caution the reader that the formulae given are a simplification of the complete method, which should include the calculation of stresses generated by outside forces on the hub (axial, radial and moments), and which should account for the stress concentrations that occur in the shaft at the plane where it enters the hub, and finally, which should include the effect of variable stresses which can fatigue the metal.

### 4. Centrifugal effect

Another factor to be used in the design of an interference fit is the negative effect of centrifugal forces on the interference. One should always provide for this effect, particularly in high speed applications. The loss of interference rate due to centrifugal forces, when both the shaft and hub are steel is:

$$i_c = .055 \times \text{rpm}^2 \times D^2/10^{12} \text{ (inch/inch)} \quad (6)$$

To give the reader an idea of the loss of interference, we calculate the following example:

$$\begin{aligned} D &= 6 \text{ inch} \\ \text{rpm} &= 10,000 \\ i_c &= .0002 \text{ inch/inch} \end{aligned}$$

This means that if the mounting interference was .0015 in./in., the effective interference at speed is .0013, or 87% of the mounting interference.

## PRACTICE

### 1. Design

#### a. Sealing

Maybe the most important design feature of a hydraulically fitted hub is the means to seal the oil sufficiently to build the large pressure needed both for assembly and disassembly. The first is more difficult. Actually, many assemblies which are built only for hydraulic disassembly do not incorporate any special seals.

As shown in Figure 4, the high pressure causes a non-uniform deflection of the hub which insures sealing at both ends. For dilating the hub at installation there is not enough interference to seal the oil, and "O" rings should be used. Two designs are predominant, as shown in Figure 5. The axial distance between the seals is larger in design "a" than in "b" of Figure 5, at least by the amount of hub advance.

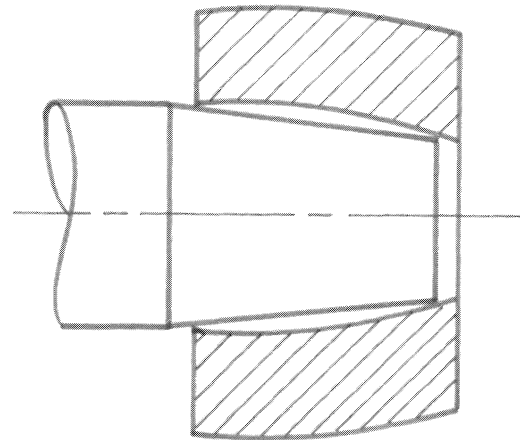

Figure 4. Hub Distortion under Hydraulic Pressure.

Although "O" rings of 90 Shore A hardness can be used singly, a safer design is to use back-up rings, which can be either nylon or hard rubber. The use of nylon back-up rings is very critical, because the shaft diameters at the "O" rings are never standard dimensions. Nylon rings are very difficult to stretch and resist normal installation. While the "O" rings *must* be toward the pressure (facing each other) and the back-up rings toward the outside (with the two "O" rings between them), the position in

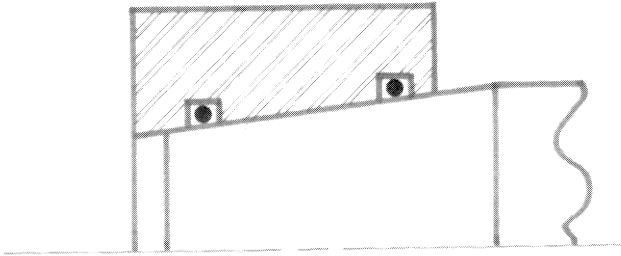
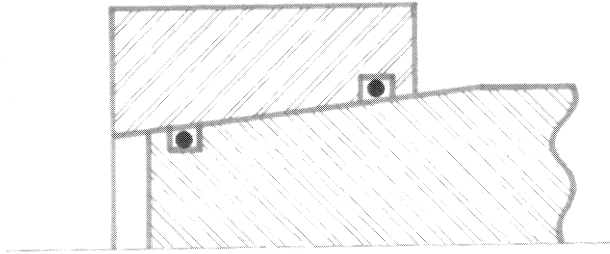

Figure 5. Typical "O" Ring Arrangements.

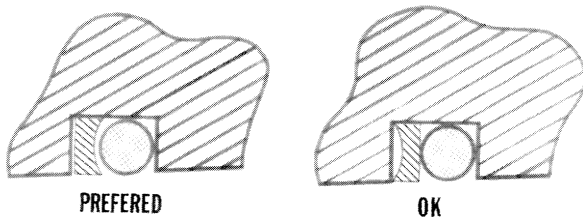

Figure 6. Back-up Ring Installation.

which each back-up ring is in the groove is not critical, as shown in Figure 6.

b. Injection holes

The oil must be injected between the hub and the shaft, and this can be done either through the shaft or through the hub, as shown in Figure 7. The author recommends design "b" in Figure 7 because the oil inlet hole is in the area of minimum stress. Suggested dimensions for the hole and groove are given in the Appendix.

c. Relieving the stress concentrations

Theoretically the contact pressure generated by the interference is uniformly distributed over the contact surface. Actually, the stresses generated by the pressure are higher at the ends. Figure 8 represents the stress distribution (in the shaft) in an interference fitted assembly. "C" represents the compressive stress due to the pressure, "S" represents the shear stress due to torque.

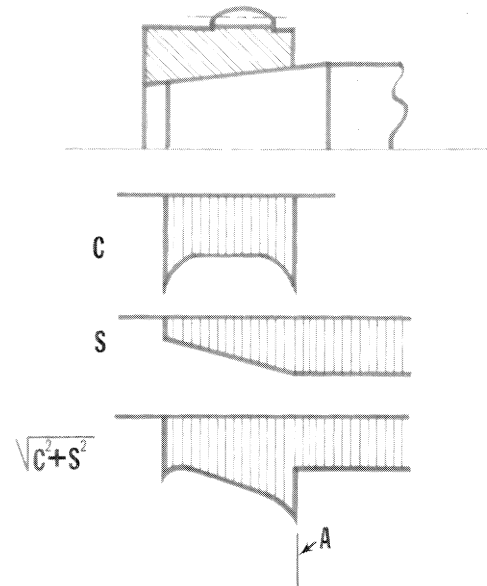

Figure 8. Stresses in an Interference Fit.

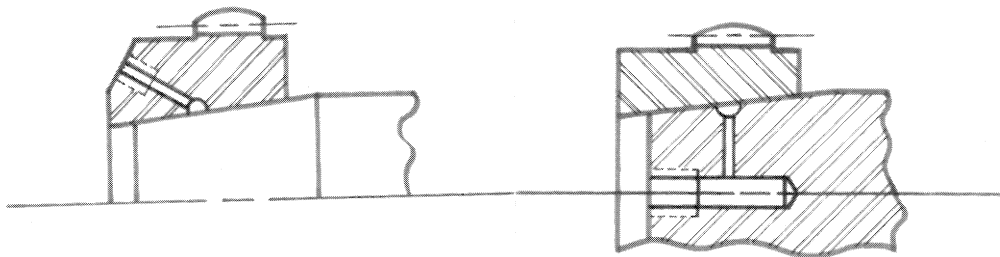

Figure 7. Oil Supply Systems.

The resultant stress is represented by  $C^2 + S^2$ . (Note: S decreases as the shaft penetrates in the hub because the torque is gradually transmitted to the hub.) The critical area for the shaft is at plane A, where an abrupt increase in stress occurs. The easiest way [3] to reduce, in a controlled way, the stresses at A is illustrated in Figure 9.

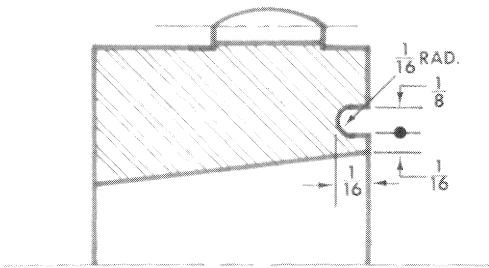

Figure 9. Stress Relief Groove.

d. Flanged hubs

A very difficult condition is also generated by flanges incorporated in the hub, such as the ones shown in Figure 10. As it can be calculated from equation (3), the contact pressure increases as the outside diameter increases. For gear and diaphragm couplings the problem is minimal for two reasons: first, because the flange is usually overhanging the hub, and secondly, because the flange is at the shaft end, where the stresses due to torque are minimal. The gear couplings have also a slight edge over the diaphragm couplings because the flange OD is usually smaller. Particularly critical is the condition generated by the reduced moment disk pack coupling, where the flange is over the critical point "A" of Figure 8. Care must be taken to relieve the possible high stress concentrations caused by this design.

e. Hydraulic line connections

The standard "pipe-thread" cannot be used in hydraulically fitted hubs because it cannot seal the high pressures encountered. Straight threads and seals should be used.

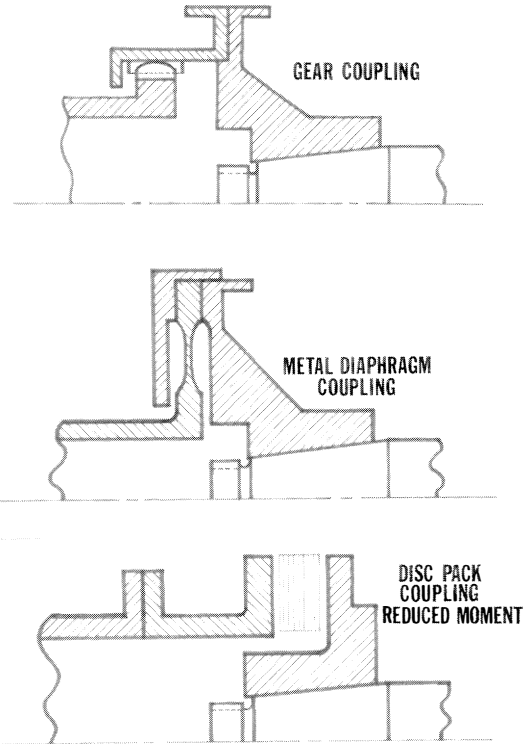

Figure 10. Three Types of Flanged Hubs.

f. Retaining devices

After the hub is installed on the shaft it is recommended that it is axially retained on it. These retaining means are only a safety precaution against improper installation. It is easy to understand that if the connection can transmit torque it can also transmit large axial forces. The formula to determine this force is:

$$F = \pi d L p \mu/2 \text{ (lb.)} \quad (7)$$

In case the installation was not properly done, the hub will slide axially away from the shaft and the joint will abruptly cease to transmit the torque. The danger of runaway turbine is great. If a mechanical lock, as shown in Figure 11 is provided, the rotational sliding of the hub

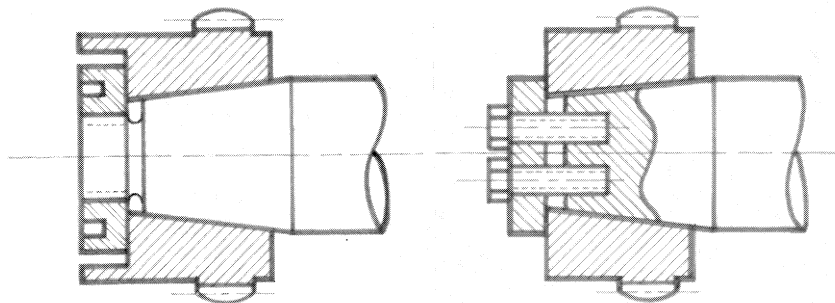

Figure 11. Axial Retaining Means.

on the shaft will generate enough heat to seize the two and prevent the loss of load to the turbine. Experience has shown that seizing can occur within one *relative* revolution.

## 2. Procedures before installation

### a. Checking the contact area.

After the surfaces are thoroughly cleaned, the contact area should be checked by using mechanics' blue. The hub should be only slightly rotated on the shaft. Some coupling users are against any rotation of the hub. If the contact area is less than 80%, the joint must be lapped. Lapping, however, should *NEVER* be done with the hubs on the shaft to avoid a possible shaft fracture. What can happen is illustrated in Figure 12. The stress concentration at point A is so large that it can cause the fatigue failure of the shaft.

### b. Lapping procedure

Proper lapping should be done with a ring and plug tool, preferably made of cast iron. The ring should be substantially longer than the hubs, and the plug should be longer than the ring. First the ring and plug should be lapped together and only after one is reasonably sure that they match perfectly, they should be used to lap the shaft and hub. A very fine lapping compound, such as 800 grit, should be used. Extreme care should be taken in cleaning the shaft and the hub after lapping. It is also recommended that the ring and plug tool should be inventoried and a record should be kept on which machine it was used.

### c. Cleaning procedure

Cleaning of the mating surfaces should be done with a solvent such as chloroethene or acetone, and the surfaces should *NOT* be wiped clean with paper towels or rags, neither should they be touched by hand after cleaning. A significant loss of torque transmission capability can be caused by dirt on the mating surfaces.

### d. Zero clearance position

In order to insure that the hub is installed with the proper interference, one must know the amount of taper and the hub advance (axial motion). The advance is measured from the "zero clearance position". To determine this position, the hub is installed on the shaft without "O" rings and in a dry condition. Care should be taken not to push the hub too rapidly on the shaft because it will freeze on it and it will be difficult to remove. Puller holes in the hub are not required and are not recommended. The hydraulically fitted hubs are highly stressed, and puller holes cause high localized stresses.

There are many methods to mark the amount of advance of the hub. Two of the preferred methods are shown in Figure 13. Method "b" has two disadvantages: if the hub advances more than required, it will cover the scribed mark and one cannot verify how much the hub advanced beyond the desired point; secondly, if the mark is scribed too deeply it can generate undesirable stress concentrations in an area which is already critical. Method "a" has none of these disadvantages but can be used only if space is available. When either method is used, it is recommended that the amount of hub overhang be measured with a depth gauge before and after installation to insure correct advance.

### e. "O" ring installation

The "O" rings and back-up rings should also be cleaned, but care should be taken not to use a solvent that will soften the rubber. The rings should be inspected for possible flashing. Although it may sound ridiculous, it is strongly recommended that the rings be handled with plastic gloves. They cost pennies apiece, and they are cheap insurance against dirt.

As a final step, the hub bore and the "O" rings should be wetted with the same oil that is being used in the

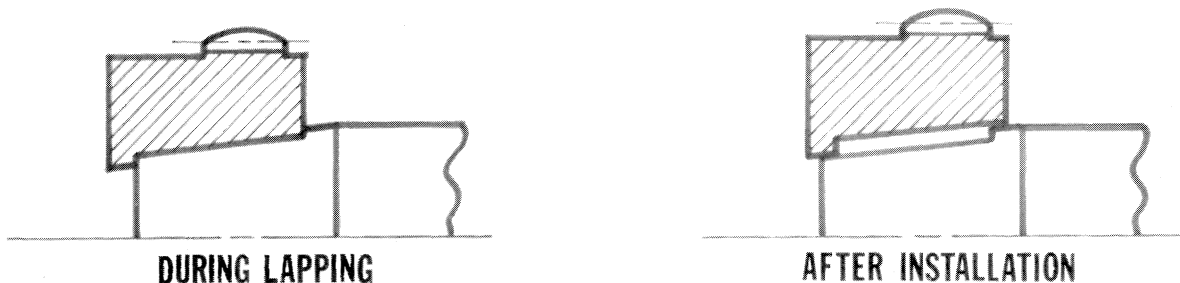

Figure 12. Consequence of Hub-On-Shaft Lapping.

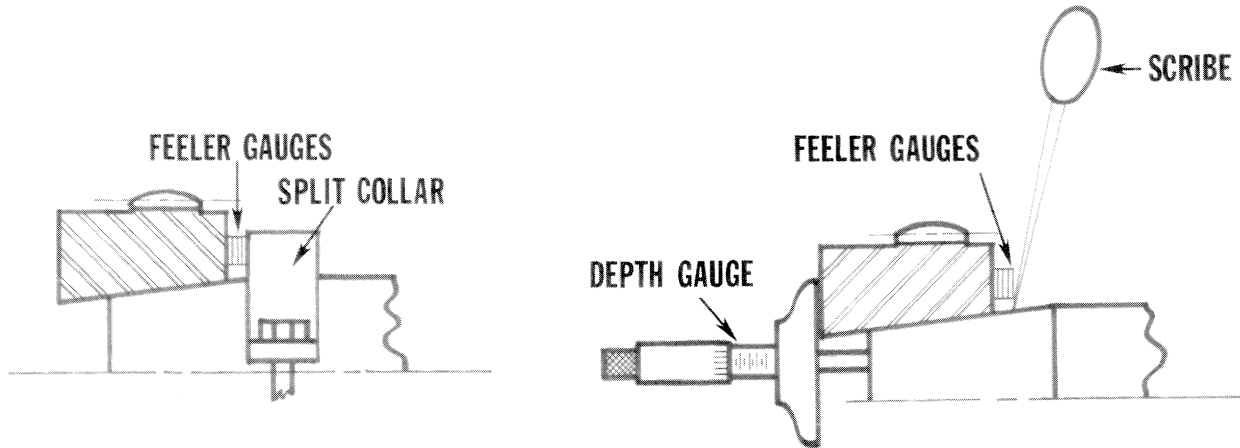

Figure 13. Means to Measure Hub Advance.

hydraulic system. Do not smear the oil with a brush or cloth. To insure cleanliness, it is best to prepare a squeeze plastic bottle and squirt the oil on the surfaces.

### 3. Installation procedure

One must understand that the hub must be subjected to two motions in order to be installed: a radial motion which increases its bore size, and an axial motion which advances it on the tapered shaft. These two motions are generated independently, and a given sequence is required for optimum results.

- a. The hub must first be advanced on the shaft so that the "O" rings and back-up rings are squeezed in the grooves, and metal-to-metal contact is insured. If pressure between the hub and shaft is applied before metal-to-metal contact exists, the rubber rings will be extruded in the space and the installation is a guaranteed failure.

The axial movement can be accomplished mechanically or hydraulically. The mechanical system, usually done through tightening the retaining nut (or plate) has the disadvantage that the rotation of the shaft must be prevented. It is obvious that the coupling cannot be used for this purpose. If the machine has a double ended shaft, the problem is simplified, but a hydraulic system, as shown in Figure 14, is easier to control. It is best to install a dial gauge on the hub to monitor its movement. Only after the axial movement has stopped completely can radial pressure be applied.

- b. While the axial motion can be generated with a standard 10,000 psi hand pump, the radial pressure requires a high pressure (50,000 psi is recommended) pump. Special fittings and small diameter steel tubing are also available from the pump manufacturers. As radial pressure is being applied, the hub must be continuously advanced on the shaft. The radial pressure should be increased to 15,000 to 20,000 psi, depending on the amount of interference desired, after which only axial motion is required.

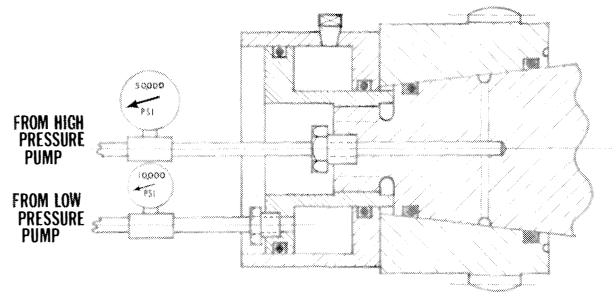

Figure 14. Hydraulic System for Hub Installation.

- c. Assuming that nothing goes wrong, the oil pressure between the hub and the shaft will continue to increase as the hub is advanced, even though no pumping is performed. This phenomenon is easy to understand when considering that as the hub is advanced, the volume between the two "O" rings decreases.
- d. Once the shaft reaches its desired axial position, the high pressure must be relieved, to allow the hub to be seated on the shaft. The oil which expanded the hub will return to the pump, but the flow is very slow considering that the film of oil can be molecular in size. One must allow about one hour before removing the advance mechanism and replacing it with the locking device. As a last thing before installation is completed, the oil orifice (in the hub or in the shaft) must be plugged to prevent the entrance of dirt.

#### 4. Hub removal procedure

- a. It is important to understand that removing a hub hydraulically involves some danger, and safety precautions must be carefully observed. Because the hub was expanded at installation, it has a substantial amount of potential energy, somewhat like a compressed spring. When the hub is being removed, this potential energy is released abruptly and transformed into kinetic energy, i.e., the hub is being accelerated axially. Pumping oil between the hub and the shaft provides the lubricant on which the hub slides. Of course, in order to introduce the oil at the interface, one must provide at least the same pressure as the one that was needed to install the hub. Another force that helps in removing the hub is the diametrical difference between the two "O" rings, which create an annular hydraulic piston. For instance, a 4 inch shaft with a  $\frac{3}{4}$  in./ft. taper and a 3 inch axial distance between "O" rings has an annular piston with an area of 1.2 inch<sup>2</sup>. If the hydraulic pressure is 25,000 psi, the resultant axial force is 15 tons.
- b. It is obvious that the hub must be stopped, or it will fly off the shaft and cause damage to itself or to anything it encounters. Figure 15 illustrates one method to stop the hub. The retaining nut is backed-off sufficiently to allow the hub to move at least the distance it advanced at installation. To dissipate the kinetic energy safely, two steps should be taken: first a lead washer ( $\frac{1}{16}$  to  $\frac{1}{8}$ " thick) is installed between the hub and the nut; second, the gap should be only .010" to .020" wider than the original advance, otherwise it will allow the hub to attain too high a velocity. The lead washer will absorb the energy through deformation. Cases are known where, without a lead washer and with a wide gap, the threaded portion of the shaft was snapped off!

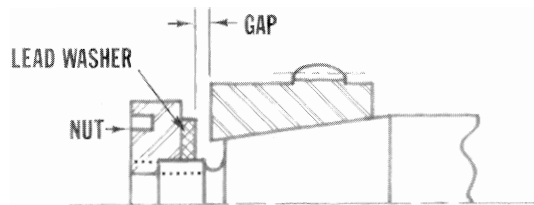

Figure 15. Means to Stop Hub Travel During Removal.

**EVEN WITH ALL THESE PRECAUTIONS, ONE SHOULD NEVER STAND IN LINE WITH THE SHAFT WHEN THE HUB IS BEING REMOVED.**

- c. Once the stop is provided, hydraulic pressure should be slowly applied. A too quick increase in pressure will not give time for the oil to wet the interface completely and localized scoring could occur. It is even possible that one

will have to wait one hour before the hub pops out. If the machine is very cold, chances are the oil will not penetrate and the hub will not be removable. In this case, one solution is to apply heat to the hub. Heating the hub over 250°F can have the opposite effect than the one desired; first, because the oil will lose much of its lubricating properties, and second, because the "O" rings can be scorched and will no longer seal. Because heat can be misused, it is best to be used only as a last resort.

- d. In very rare cases, even pressures as high as 35,000 psi will fail to move the hub. Usually this happens if dirt is trapped between the hub and the shaft, or if rotational slippage took place under torque. External axial force should then be applied, in addition to the hydraulic pressure. Increasing the pressure above 35,000 psi is not advisable because it can either yield the hub or it will blow the "O" rings out. If the hub cannot be removed because enough pressure cannot be generated, one can fill the oil passages between the pump and hub with a highly viscous oil, which is easier to seal. The high pressure pump should be filled only with hydraulic oil.

#### CONCLUSIONS

First, we can draw some interesting conclusions if we rearrange the formulae. It is known that the shear stress due to torque in a cylindrical shaft is

$$\tau = (16T/\pi) d^3 \text{ (lb./in.}^2\text{)} \quad (8)$$

Combining formula (8) with equations (1), (2), (3) and (4), gives us

$$\tau = 8\sigma\mu \frac{2}{\sqrt{3 + c^4}} \text{ lb./in.}^2 \quad (9)$$

Combining formulae (3) and (4) yields

$$i = \frac{\sigma}{E} \times \frac{2}{\sqrt{3 + c^4}} \text{ (in./in.)} \quad (10)$$

We will now introduce some usual numerical values:

- hub material (alloy steel) yield stress = 95,000 lb./in.<sup>2</sup>
- E = 30,000,000 lb./in.<sup>2</sup> for steel
- c (shaft diameter/hub O.D.) = .67
- $\mu = .12$

We obtain:  $i = .003$  (in./in.)

$$\tau = 24,150 \text{ (lb./in.}^2\text{)}$$

(Note: See Appendix for calculations.)

These two values are in themselves interesting conclusions:

- a. One should use less than .003 in./in. interference, and
- b. The maximum shear stress in the shaft can be much larger than the one used now with keyed connections.

Also:

- c. From experience, we conclude that it is easier to install, and in particular to remove, a hydraulically fitted hub than a keyed hub. A hub can be repeatedly installed on its shaft without any damage to the bore or shaft surfaces.
- d. A hub can be removed much faster hydraulically than mechanically, which shortens the downtime.



- e. The hydraulic removal method permits quick access on site to the seals; heating the hubs is no longer required.
- f. Just as is the case with any modern tool, using the hydraulic method requires more training and more care than with the old method.
- g. We foresee that most new turbomachinery as well as related motors and gearboxes will be equipped with hydraulically fitted hubs.

**ACKNOWLEDGEMENT**

The author expresses his sincere thanks to Messrs. Stanley G. Webb and Charles Jackson for their help and advice in the writing of this paper.

**APPENDIX**

1. Oil distribution grooves, from reference [2].

d	B	C	H	R
2 to 4	5/32	1/8	1/32	1/8
4 to 6	3/16	5/32	3/64	5/32
6 to 8	15/64	3/16	3/64	11/64
8 to 10	9/32	3/16	1/16	3/16
10 to 12	5/16	15/64	1/16	15/64
12 to 16	25/64	9/32	3/64	9/32
16 to 20	15/32	5/16	3/32	5/16

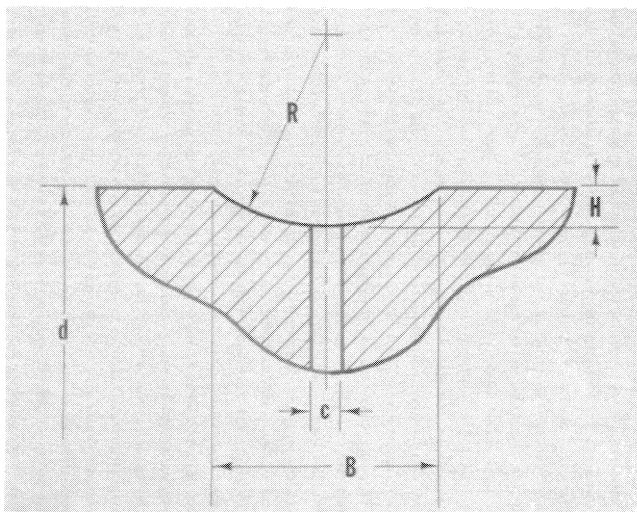

Figure A-1. Oil Distribution Groove.

2. Stresses in a press-fit connection.

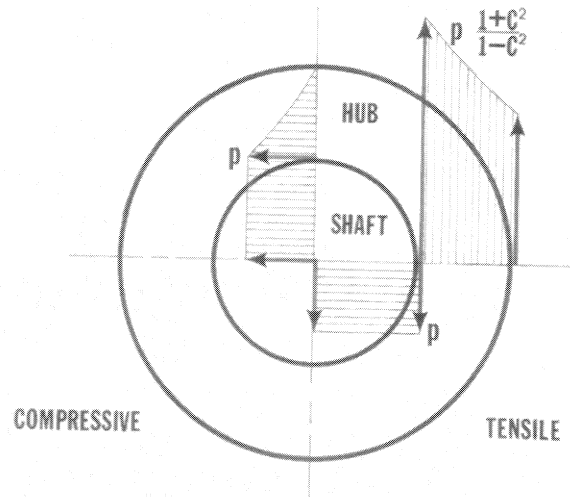

Figure A-2. Stress Distribution in Hub and Shaft.

3. Hub growth due to interference.

The ratio between the bore growth and the shaft shrinkage [1] is:

$$r = \left( \frac{D^2 + d^2}{D^2 - d^2} + \mu \right) / (1 - \mu) \quad (A-1)$$

where  $\mu$  = Poisson ratio, .3 for steel.

For the usual practice of  $D/d = 1.5$ , we obtain

$$r = 4.14$$

For example, if we have  $d = 4''$ ,  $D = 6''$ , and  $i = .002$ , total diametral interference is  $4 \times .002 = .008''$ .

The bore growth is  $\frac{.008 \times 4.14}{1 + 4.14} = .0064''$ , and the shaft shrinkage is  $.0016''$ .

The growth of the hub's outside diameter is easy to obtain:

$$(id) \times \frac{d}{D} = .008'' \times \frac{4}{6} = .0053''$$

4. Numerical calculations from CONCLUSIONS.

From Figure 3, with  $c = .67$ ,  $K = 86$ .

Maximum acceptable stress for a material with 95,000 lb./in.<sup>2</sup> yield is

$$\sigma = .86 \times 95,000 = 81,700 \text{ lb./in.}^2$$

From formula (10), we have

$$i = \frac{81,700}{30 \times 10^6} \times \frac{2}{\sqrt{3 + .67^4}} = .003 \text{ in./in.}$$

From formula (9), we have

$$\tau = 8 \times 81,700 \times .12 \times \frac{1 - .67^2}{\sqrt{3 + .67^4}} = 24,150 \text{ lb./in.}^2$$

## BIBLIOGRAPHY

1. Timoshenko, S., *Strength of Materials*, 3rd ed. (Van Nostrand, 1958), Part II, pp. 205-213.
2. *Oil Injection Method*, SKF, Sweden, Publication No. 2930 E, September 1976.
3. Ker Wilson, W., *Practical Solution of Torsional Vibration Problems*, 3rd ed. (Wiley & Sons, 1956), Vol. III, pp. 316-322.
4. Lingaiah, K., and Gargesa, G., "A New Design Factor for a Shrink Fitted Assembly", ASME Paper 75-DE-50.
5. Calistrat, M. M., "Torsional Stiffness of Interference Fit Connections", ASME Paper 72-PTG-37.
6. "Hydraulic Fit Couplings", *AMOCO Machinist Grapevine*, No. 91, July 1976.
7. Loewenthal, S. H., "Proposed Design Procedure for Transmission Shafting Under Fatigue Loading", *Proceedings of the National Conference on Power Transmission*, Illinois Institute of Technology, Vol. V, 1978, pp. 197-204.
8. Bloch, H. P., "Use Keyless Couplings for Large Compressor Shafts", *Hydrocarbon Processing*, April 1976, pp. 181-186.
9. Sullivan, J. L., "Guarding Against Fatigue Failure in Press-Fitted Shafts", *Machine Design*, June 9, 1977, pp. 102-106.