

# RETROFITTING TURBOMACHINERY WITH HIGH PERFORMANCE FLEXIBLE DRY COUPLINGS

by

Christian C. Wolford

Manager of High Speed Products

Zurn Industries, Incorporated

Erie, Pennsylvania



*Christian C. Wolford is the Manager of High Speed Products for Zurn Industries, Incorporated, Mechanical Drives Division in Erie, Pennsylvania.*

*At Zurn, he is responsible for business development of high performance couplings in the petrochemical and process markets.*

*Mr. Wolford is a Westminster College alumnus, where he studied mathematics.*

## ABSTRACT

When planning maintenance of turbomachinery, the proper selection of dry couplings to replace gear couplings should be considered. The basic criteria used when retrofitting flexible diaphragm or disc couplings is discussed.

## INTRODUCTION

Introduced in the early 1970s, dry couplings have been widely accepted in the petrochemical and process industries. Most new turbomachines incorporate diaphragm or disc type couplings rather than gear couplings. With the many advantages of dry couplings, retrofitting has become an attractive option. Some of these advantages include the elimination of maintenance, low moments and forces on connected equipment, long life, and low residual unbalance.

Although flexible couplings are often thought of as a "necessary evil" rather than an integral part of the machinery, they must perform satisfactorily for extended periods. The dry type coupling, if properly applied, can improve the performance of most trains initially installed with gear type couplings. However, an improperly applied dry type coupling can create many serious problems if consideration is not given to the design differences. Quite often couplings are used to "tune" a multiple bodied train. The rotordynamic response can be greatly influenced by a change in the coupling's mass distribution.

In addition to the basic information required to size a coupling, there are several areas of consideration for proper retrofit selection. The most significant coupling characteristics to be considered are:

- Weight and center of gravity ( $C_G$ ) location.
- Torsional stiffness.
- Axial natural frequencies.
- Lateral critical speed.
- Windage/temperature rise.
- Equipment envelope.
- Axial travel capacities.

## WEIGHT AND CENTER OF GRAVITY LOCATION

One of the first considerations should be to match the weight and center of gravity location of the half coupling. A turbocompressor's lateral vibration characteristics or "critical speed" can be affected by changing the weight and/or center of gravity ( $C_G$ ) location of the coupling. The closer a machine's operating speed range is to a "critical speed," the more reactive the rotor is to unbalance. For the equivalent torque capacity dry couplings are generally heavier than gear couplings. Because of this, guidelines should be established to insure successful operation. The following guidelines are sometimes used:

- If the operating speed is less than 3,600 rpm the weight of the new coupling should be within 20 percent of the existing coupling.
- Between 3,600 rpm and 6,000 rpm the weight should fall within 15 percent.
- Over 6,000 rpm the weight should be within 10 percent.

The sensitivity of the machines must be considered when applying these guidelines. If the coupling weight is an appreciable percentage of the rotor weight, very little deviation may be tolerated. Actually, it is the half-weight which is considered. The half-weight is the portion of the coupling supported by each shaft. The above guidelines are valid only when the half-weight is at the same  $C_G$  location for both the gear and the proposed dry type coupling.

The overhung moment of the coupling should be the dominant concern when retrofitting. The overhung moment is the product of the coupling's half-weight and the distance from the centerline of the machine's support bearing to the  $C_G$  location, as shown in Figure 1.

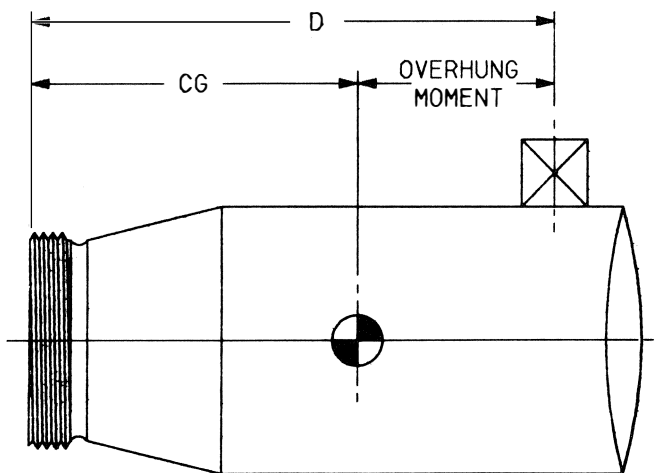

Figure 1. Overhung Moment of Shaft End.

The following example illustrates the point:

	$\frac{1}{2}$ Weight	C Location	Bearing $C_G$ to Shaft End	Overhung Moment
Gear Coupling	45.0 lbs.	(-)2.0 in.*	9.0 in.	315.0 lb. in.
Dry Coupling	45.0 lbs.	(+)5 in.*	9.0 in.	427.5 lb. in.

\*(-) (+) indicates C location with reference to the shaft end where (-) is in the direction toward the machine.

Depending on the sensitivity of the equipment, a change in overhung moment of any magnitude could result in a lateral critical frequency close to the operating speed range. Conversely, a study of the overhung moment often results in a successful retrofit where duplicating the weight of the existing coupling is not possible. The following demonstrates the results when compared with the previous example:

	Weight	C Location	Bearing $C_G$ to Shaft End	Overhung Moment
Gear Coupling	45.0 lbs.	(-)2.0 in.	9.0 in.	315.0 lb. in.
Dry Coupling	52.5 lbs.	(-)3.0 in.	9.0 in.	315.0 lb. in.

Duplicating the overhung moment should also be considered as a guideline, because it assumes that there is no shaft deflection in the overhang.

Rotordynamicists will debate whether the distance from the journal bearing centerline to the half-coupling  $C_G$  location should be "squared" or "cubed" to assess coupling influence on the second (bending) critical speed. Good results have been shown using the distance "squared."

## TORSIONAL STIFFNESS

The next area of consideration should be the coupling's torsional stiffness or  $K_T$ . Like the lateral critical frequency, a multirotor train's torsional response can be greatly influenced by the coupling. There are several methods of torsionally tuning a coupling to duplicate the  $K_T$ . The easiest method is to design the spacer inner diameter (ID) to outer diameter (OD) ratio to match the  $K_T$  of the gear coupling. There are limits when increasing the spacer thickness, however, as this may add too much overhung weight. Conversely, thinning the spacer tube increases the spacer shear stress and could affect coupling service factor. Materials of construction such as stainless steel, titanium, or composites can be utilized to torsionally tune the spacer where weight or spacer shear stresses are of concern. The coupling design can also be optimized to change the spacer length. Regardless of the method, it is important to match the  $K_T$  of the existing coupling. It should be noted that torsional stiffness calculation methods vary. Today, most coupling manufacturers assume a  $\frac{1}{2}$  shaft penetration versus full shaft penetration which was the standard for many years.

## AXIAL NATURAL FREQUENCIES

Dry couplings exhibit an axial natural frequency not common to gear couplings. Metallic membrane couplings rely on deformation of the membrane to accommodate misalignment. This deformation is accompanied by a resulting force attempting to restore it to its original shape. Consequently, the coupling may resonate along the axis of rotation in what is referred to as its axial natural frequency (ANF). When analyzing this vibration, the coupling spacer acts as a mass suspended between two springs in parallel. A simple example is shown in Figure 2. As the coupling rotates, there may be axial excitations initiated by gear eccentricities, shaft, or thrust bearing runout. This reso-

nance is dependent on the magnitude of these axial excitations as a function of the membrane's axial stiffness. If a coupling is run near an ANF, it can resonate at least at the amplitude of its linear stiffness axial travel range. Amplitudes of 30 to 35 times the magnitude of the excitation at the ANF are possible [1].

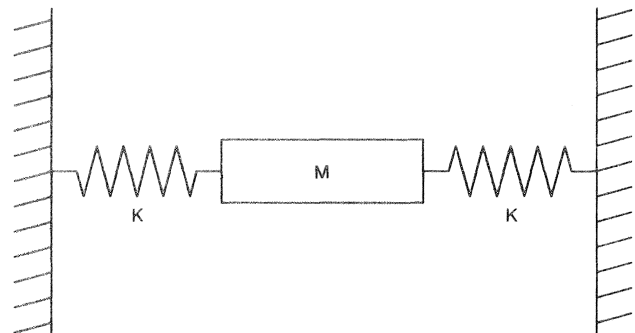

Figure 2. Spring-Mass System.

Some turbomachinery users have experienced field problems related to the coupling's ANF. It is very difficult to predict whether a train will have significant excitations so it is best to avoid operating at or near the coupling's ANF. A basic criteria has been established by API-671 [2] which reads as follows:

2.3.4 Actual axial natural frequencies of the coupling shall not fall within 10 percent of any of the following:

1. Any speed within the range from minimum allowable speed to the maximum continuous speed.
2. Two times any speed within the above speed range.
3. Any other speed or exciting frequency specified by the purchaser.

When retrofitting, it is important to include all operating speed ranges, including minimum and maximum continuous speeds, in order to avoid a potential problem which can affect the entire drive train.

There are effective ways to change a coupling's ANF. The spacer weight can be changed by altering the ID to OD ratio. Changing the number or thickness of the membranes can also effectively change the spring rate. If these methods fail, some dry couplings can incorporate air dampers which control the amount of air pressure around the flexing element and dampen the excitation.

## LATERAL CRITICAL SPEED

The lateral critical speed is a critical speed wherein the coupling vibrates back and forth sideways much like a guitar string. It must also be considered as part of the retrofit criteria. A check to ensure the coupling's "lateral critical" is a minimum of 1.5 times the operating speed is a good "rule of thumb."

## WINDAGE/TEMPERATURE RISE

For a given torque capacity, dry couplings are usually larger in diameter than gear couplings and, therefore, generate more heat by windage. This heat generation relates to the coupling's proximity to the equipment casing and guard as a function of speed. When retrofitting, particularly for reduced moment designs, a basic criteria should include heat generation calculations. To determine the temperature rise in the housing and guard, two types of horsepower losses are considered.

- Disk windage loss for a coupling is:

$$hp_{\text{loss disk}} = \text{rpm}^{2.85} \frac{1}{K_1} \frac{S}{D} \quad (1)$$

where D and K<sub>1</sub> are found on the horsepower loss constant chart as shown in Figure 3 for the proper size of coupling. S (in) is the distance from the coupling flange face to housing. This equation is to be applied to each end of the coupling. If S/D is greater than 1.0, use S/D = 1.0.

D (in.)	K <sub>1</sub> X 10 <sup>10</sup>
6	2460
9	372
13	67.6
17	19.3
23	4.76

Figure 3. Typical Horsepower Loss Constant Chart.

- Cylinder windage loss: The cylinder windage power correlation with rpm, diameter, and length is:

$$C_{\text{losses}} = \text{rpm}^3 \times \Sigma \text{diameter}^4 \times \text{length}$$

The equation to find the horsepower loss for a cylindrical section is:

$$hp_{\text{loss cylinder}} = E \times L \times Cf \quad (2)$$

where

$$E = \text{rpm}^3 \times D^{3.859} \times 5.5 \times 10^{-15}$$

D = diameter of section (in.)

L = length of section (in.)

Cf = cylinder friction coefficient

$$Cf = \frac{128B + 2.075}{B(\text{rpm})(D)^2} + 0.0015$$

$$B = \frac{\text{diameter of guard} - \text{diameter of section}}{\text{diameter of section}}$$

This is done for each section and all the values of hp<sub>loss cylinder</sub> are summed together.

- Total windage loss. Add the disk hp loss and cylinder hp loss for the total hp loss:

$$hp_{\text{loss total}} = hp_{\text{loss disk}} + \Sigma hp_{\text{loss cylinder}}$$

To find the assumed temperature (A<sub>g</sub>) of the guard or housing, take the area of the guard, A<sub>g</sub> (ft<sup>2</sup>), and divide it into the hp loss total where:

$$A_g = \pi \times D_G \times L + \frac{D_G^2}{2} \quad (3)$$

D<sub>G</sub> = diameter of guard (ft)

L = length of guard (ft)

From Figure 4 for the total hp/A<sub>g</sub> and the correct ambient temperature, T<sub>a</sub> (°F), find T<sub>gl</sub> the assumed temperature of the guard (°F). If T<sub>gl</sub> ≤ 175°F, use this scaling technique to find the actual hp<sub>loss</sub> and operating temperature of the guard.

$$hp \times = hp$$

Again, from Figure 4, find the operating temperatures (F°) [3].

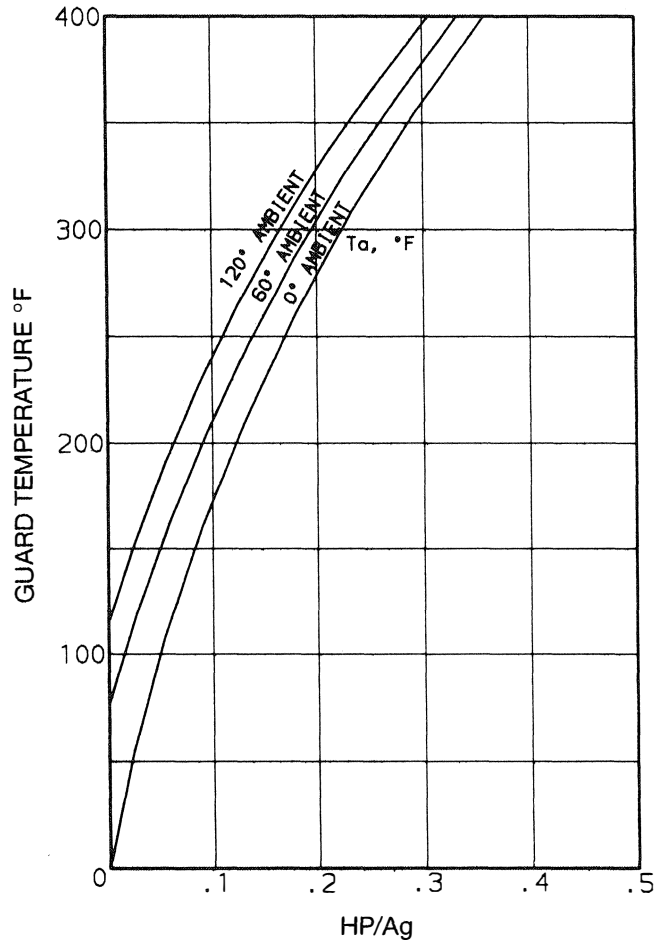

Figure 4. Temperature Rise Vs HP/Ag.

Bolt windage should also be considered as part of the heat generation calculation.

The larger windage created by dry couplings often results in redesign or modification of the guard. When windage problems exist in the machine's housing special reduced windage packages may be required as part of the coupling design. There have been cases where dry couplings, due to low pressure created in the housing, have developed a sufficient pressure differential to pull the lubricant from the machine's bearing and cause bearing failure. When the back face of the coupling is closer than 1.5 in from the bearing cage, consideration should be given to a "vacuum-breaker" labyrinth.

On applications where a two inch radial clearance exists between the coupling OD and the guard or housing, these calculations are generally not required.

## EQUIPMENT ENVELOPE

In addition to the potential problems created by windage, it is important to check the envelope dimensions to ensure the new coupling will have no physical restrictions. A review of the envelope should include location of probes, piping, baffles, lubrication nozzles, turning gear equipment, and drainhole.

## AXIAL TRAVEL CAPACITIES

Axial considerations should be included as part of the retrofit process. Gear couplings accommodate axial movement by sliding of the hub gear teeth in the sleeve. Axial positioning is, therefore, not as critical when compared with dry couplings. When retrofitting, it is important to accurately determine the shaft separation, thermal growth of the machines, and the direction of growth. Most machine shafts grow toward each other as they warm up, and the coupling must accommodate this movement. The coupling is designed to handle this by stretching the flex element at installation, so that as the machines grow together the membrane moves to a neutral position. The "pre-stretch" is normally designed into the coupling by changing the spacer length. For this reason, it is important to include the thermal growth of the machines as part of the retrofit criteria. In most cases dry couplings have sufficient axial travel capacity. For inaccuracies in the "between shaft end dimension" (BSE), shims are supplied on dry couplings for axial adjustability.

## OTHER CONSIDERATIONS

- Other items to be considered when retrofitting include:
- Unusual angular misalignment requirements.
  - Torque carrying capacity of the interface connection.
  - Dynamic balance method.
  - Any unusual operating conditions including ambient temperatures.
  - Corrosive environment considerations.
  - Accessibility for installation of larger diameter couplings.
  - Applicable service factor.

## THE ROTORDYNAMICS STUDY

The alternative to matching the existing coupling characteristics is to perform train torsional and lateral rotordynamics analyses. The rotor studies are done using the proposed coupling's mass elastic data. This alternate is generally done as a last resort when the retrofit criteria cannot be met or when no data is available on the existing coupling. Rotordynamic analyses are time consuming and may exceed the cost of the retrofit dry coupling. The cost of these analyses, however, far outweigh the potential costs associated with rotordynamic problems resulting from an incorrect coupling selection. In some cases, only one analysis may need to be studied. If the proposed coupling half-weight and  $C_C$  location are duplicated lateral analysis is not usu-

ally necessary. Matching the  $K_T$  avoids the need for train torsional analysis. The number of required rotor analyses depends on the number of machines in the train and their proximity to lateral and torsional frequencies with respect to the operating speed range.

Those involved with rotating equipment in the petrochemical plant sometimes underestimate the complexities of high performance couplings. The question often arises as to who should be involved in the retrofit process. There are basically two avenues available to the user—the original equipment manufacturer (OEM) and the coupling manufacturer.

The OEM generally offers the greatest advantages. The following are some of these advantages:

- Turbomachinery technical expertise
- Availability of existing coupling data, envelope dimensions
- Historical data
- Rotordynamic analyses capability

• Availability of gages—The taper plug gage is often a topic of discussion by itself. The OEM is often hesitant to lend the taper gage on retrofits that do not involve them. Normally, the gages can be rented by the user, but this should be considered when comparing costs if the user requires its use.

If the necessary data is available and a rotor study is not required, many users prefer to deal directly with the coupling manufacturer. The obvious advantage is the cost savings. Most OEMs justify a premium because of their services.

## CONCLUSION

Flexible couplings are a vital component in the turbomachinery train. When retrofitting with dry couplings, general guidelines must be established and followed. Dry couplings are not difficult to understand, but they are an engineered product and different from gear couplings. With the high cost of equipment downtime in the petrochemical industry today, it is important to take the necessary steps to ensure trouble free operation of the equipment and components.

## REFERENCES

1. Landon, F. K. and Counter, L. F., "Axial Vibration Characteristics of Metal Flexing Couplings," *Proceedings of the Fifth Turbomachinery Symposium*, Turbomachinery Laboratory, Department of Mechanical Engineering, Texas A&M University, College Station, Texas (1971).
2. American Petroleum Institute, "Special-Purpose Couplings for Refinery Services," API-Standard 671, First Edition (December 1979).
3. Mancuso, J. R., *Coupling and Joints: Design Selection and Applications*, New York: Marcel Dekker, Incorporated (1986).