

Solving Structural Vibration Problems Using ODS Analysis

37th Turbomachinery Symposium
September 8-11, 2008

Presented by:

Maki M. Onari & Eric J. Olson

Mechanical Solutions, Inc.

Whippany, NJ 07981 USA

Tel: (973) 326-9920

Fax: (973) 326-9919

www.mechsol.com

Vibration Testing

- **Operational testing determines the natural excitation response of the Turbomachinery.**
 - ❖ **Steady operation is monitored to determine the Operating Deflection Shapes (ODS).**
 - ❖ **Transient operation is monitored (particularly for variable speed machines) to determine problematic coincidences of excitation sources and natural frequencies.**
- **Modal testing determines the natural frequencies of the structure and the rotor system.**

Operating Deflection Shape

- **Natural excitation signature of Turbomachinery.**
- **Over 300 vibration measurements (structural and shafting).**
- **Data base of amplitude vs. frequency and phase angle (reference signature).**
- **3-D CAD model assigning motion to each individual vibration data point.**
- **Create animations of the equipment with exaggerated motion (but consistently scaled) of operating machinery at any given frequency.**

Operating Deflection Shape

Example: Single stage steam turbine



3-D CAD model of the steam turbine with all vibration measurement locations using tri-axis accelerometers

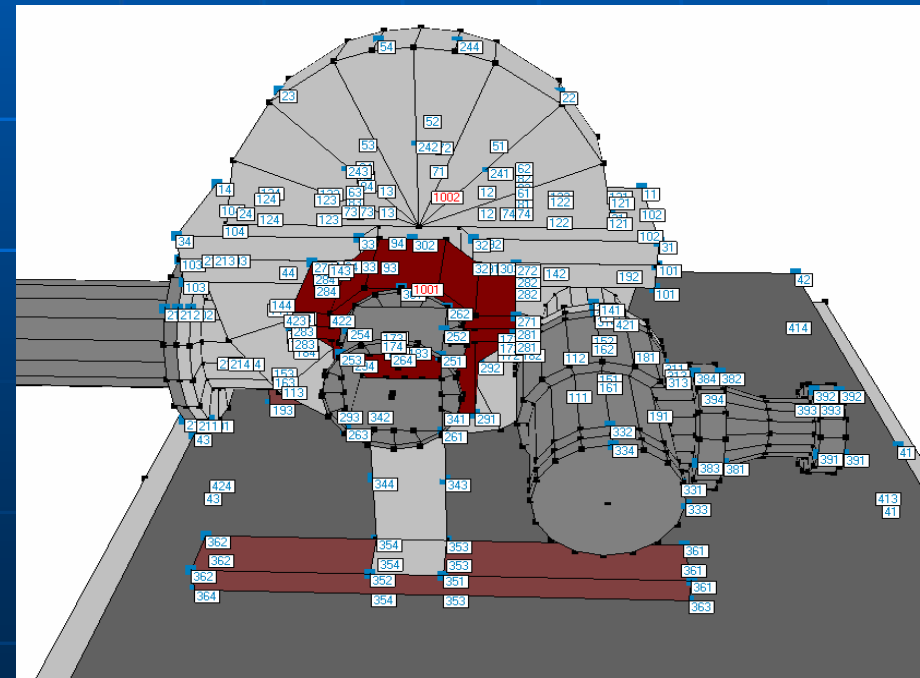

Operating Deflection Shape

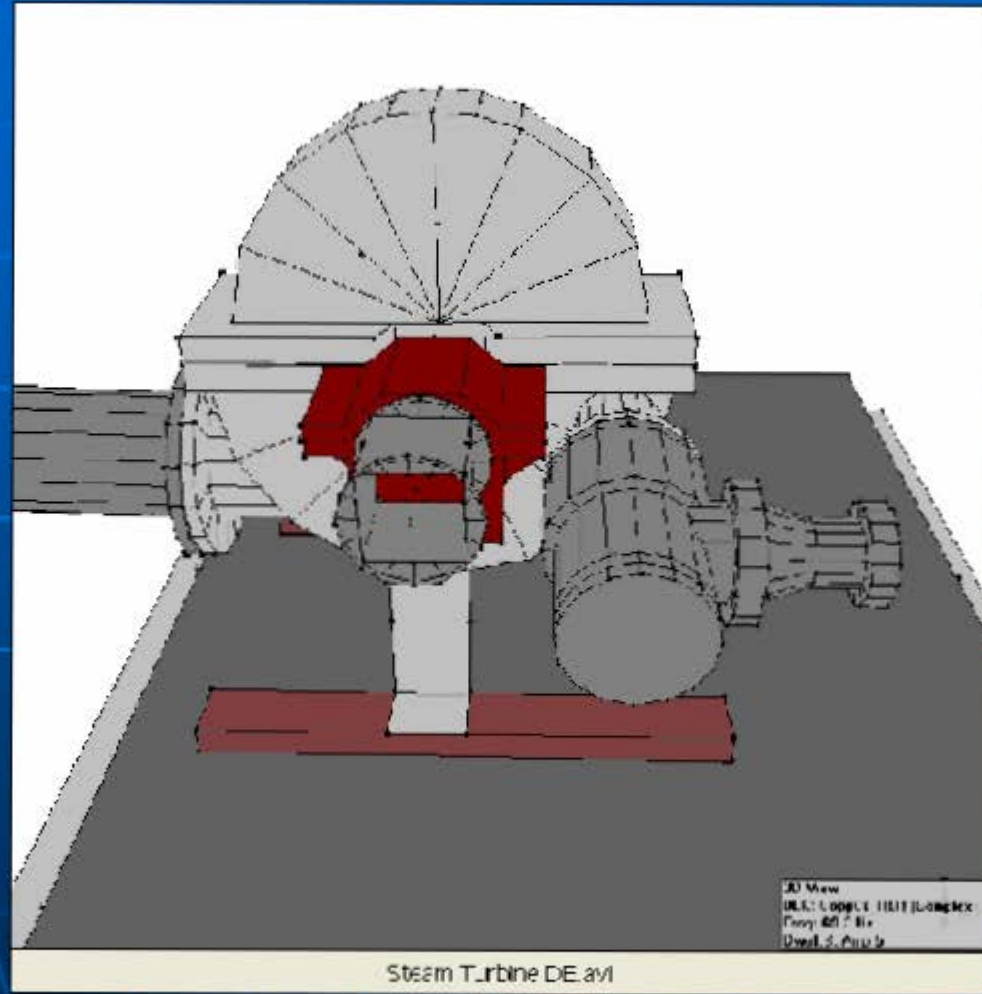

CASE 1

Steam Turbine Casing Cracking

Problem Statement

- LPB section casing of a 660 MW steam turbine in a tandem-compound reheat unit in Indonesia.
- Excessive vibration and occasional cracking of the exhaust hood frame.
- “Identical” units installed in other facilities without vibration and cracking issues (differences in actual structural dimensions).

ODS Animation at Running Speed

- Coincident resonance condition between the second bending mode of the rotor system and a sway mode of the casing close to the running speed of the unit at 50 Hz.
- The 2nd bending of the shaft was predicted with a rotordynamic analysis.

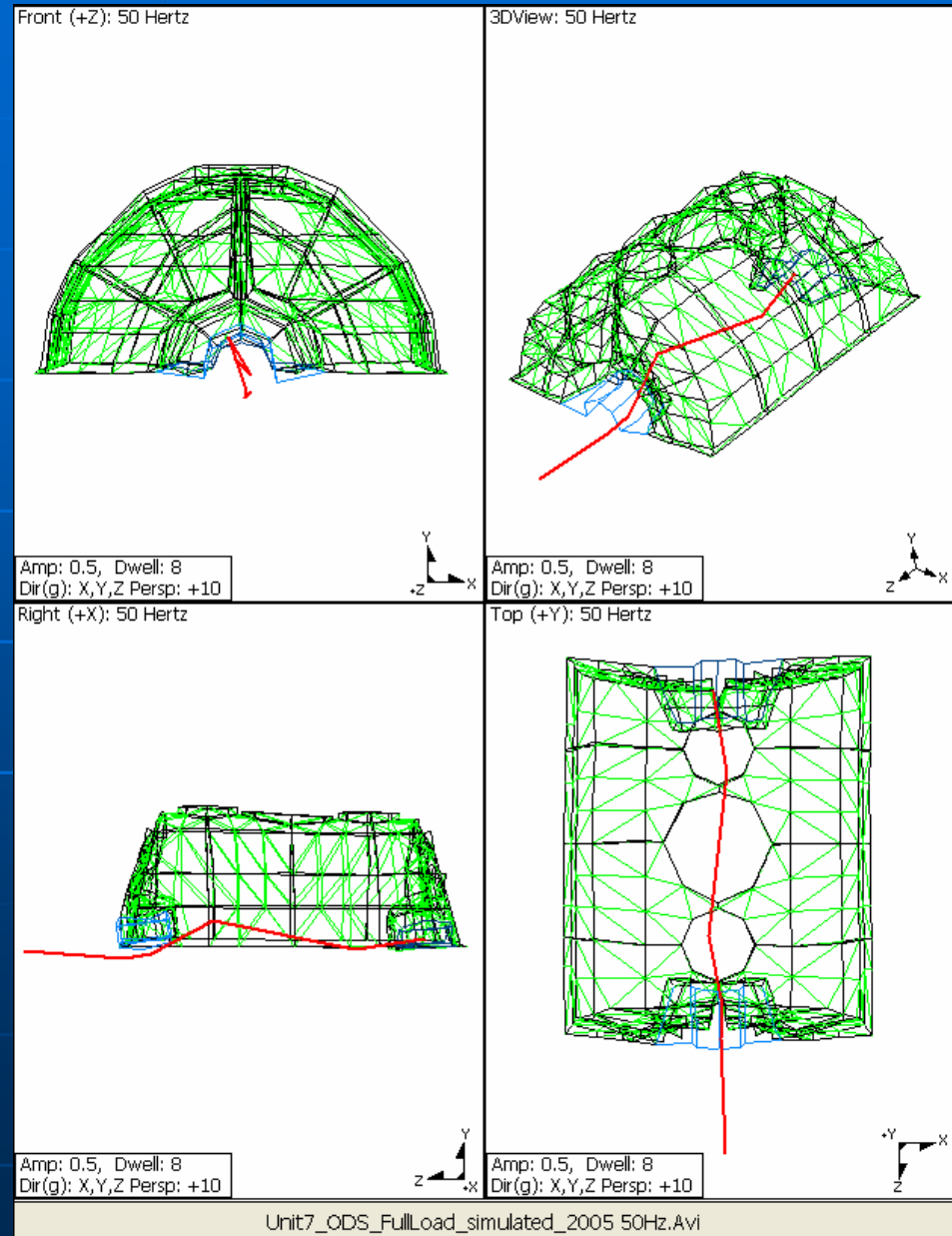

Solution

- **Structural modification of turbine casing, supported by an FEA analysis and agreed to by the OEM without interfering with the internal flow path of steam.**
- **Bearing and bearing housing stiffness increased**
- **Welded “fish-plating” to stiffen the vicinity where the cracking took place.**

CASE 2

Refrigeration Compressor Discharge Piping Cracking Failures

Problem Statement

- Repetitive failures (3) of the discharge piping on a single stage refrigeration compressor in a business building refrigeration plant since its installation in 2001.
- Refrigerant leaking due to cracks at the welding location between the pipe and the compressor flange, and between the condenser and the nozzle.

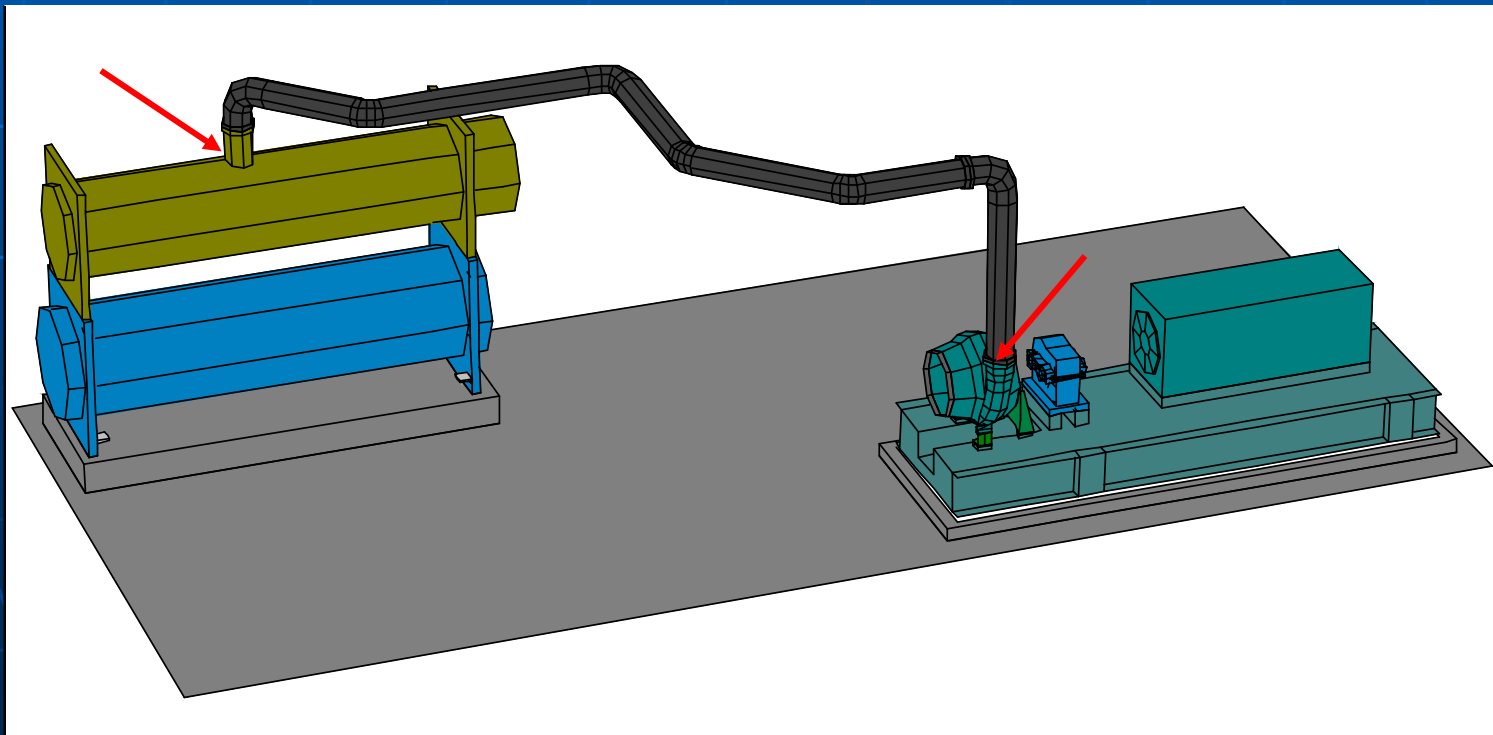

ODS Animation

- Natural frequency excited by a pressure pulsation (rotating stall) from the compressor while the unit operated at 50% of capacity sharing the refrigerating load with the sister unit.
- Bending stresses from strain gage close to endurance limit.

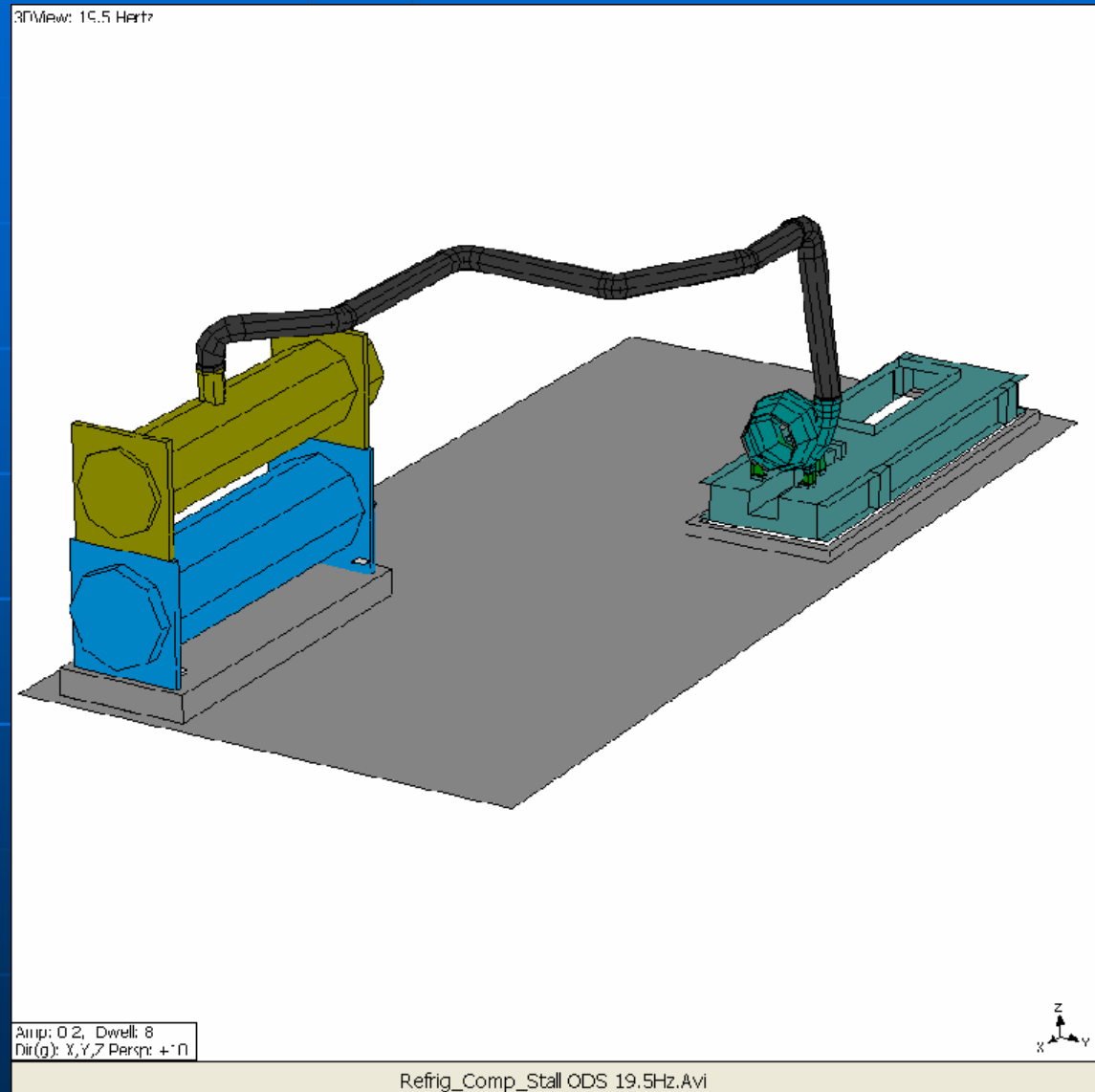

Supporting Information

- Dynamic pressure pulsation spectrum from the discharge of the compressor.

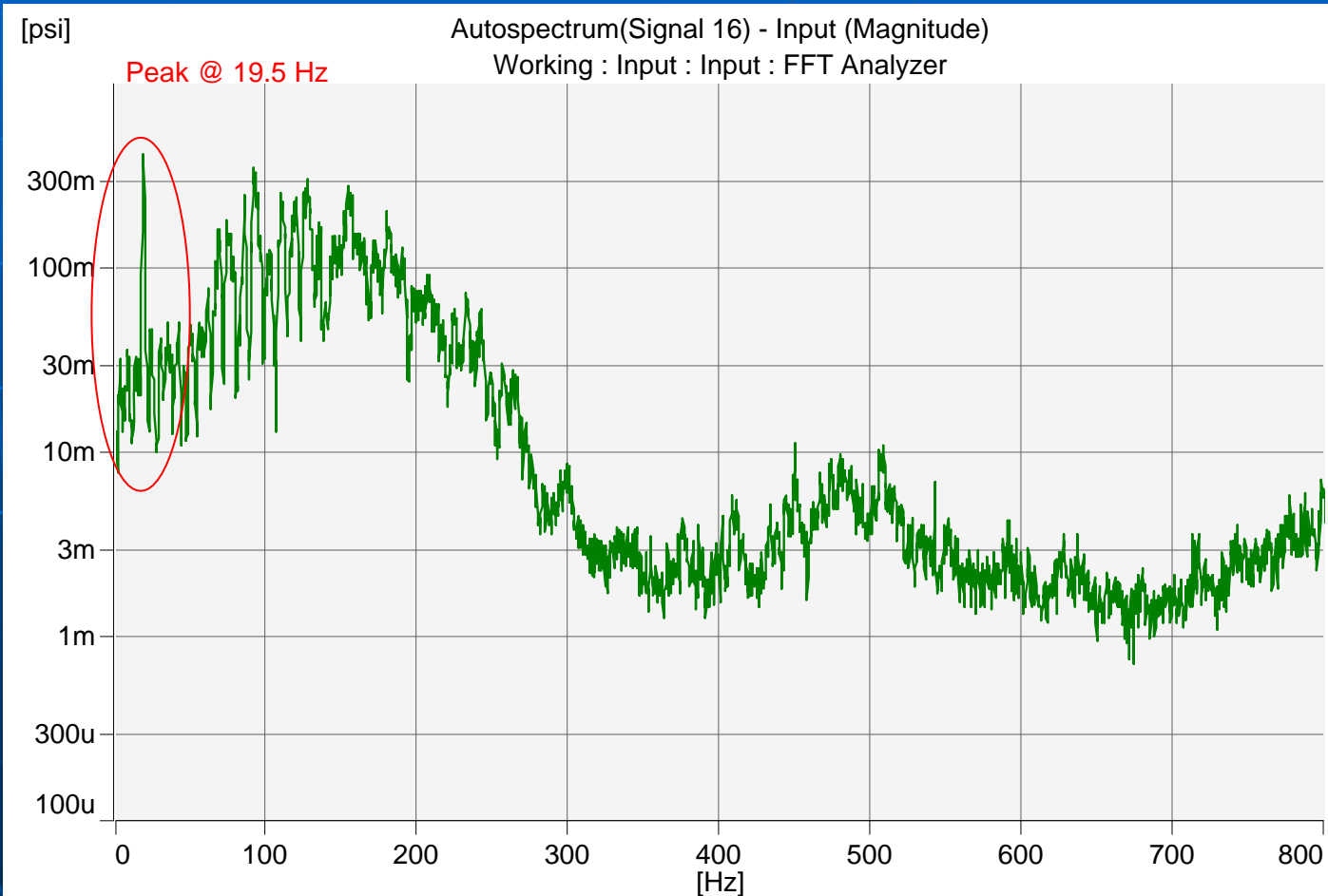

Solution

- Addition of specific masses at certain locations of the discharge piping detuned the offending natural frequency from the rotating stall pressure pulsation frequency from 19 Hz to 16 Hz (supported by FEA analysis).

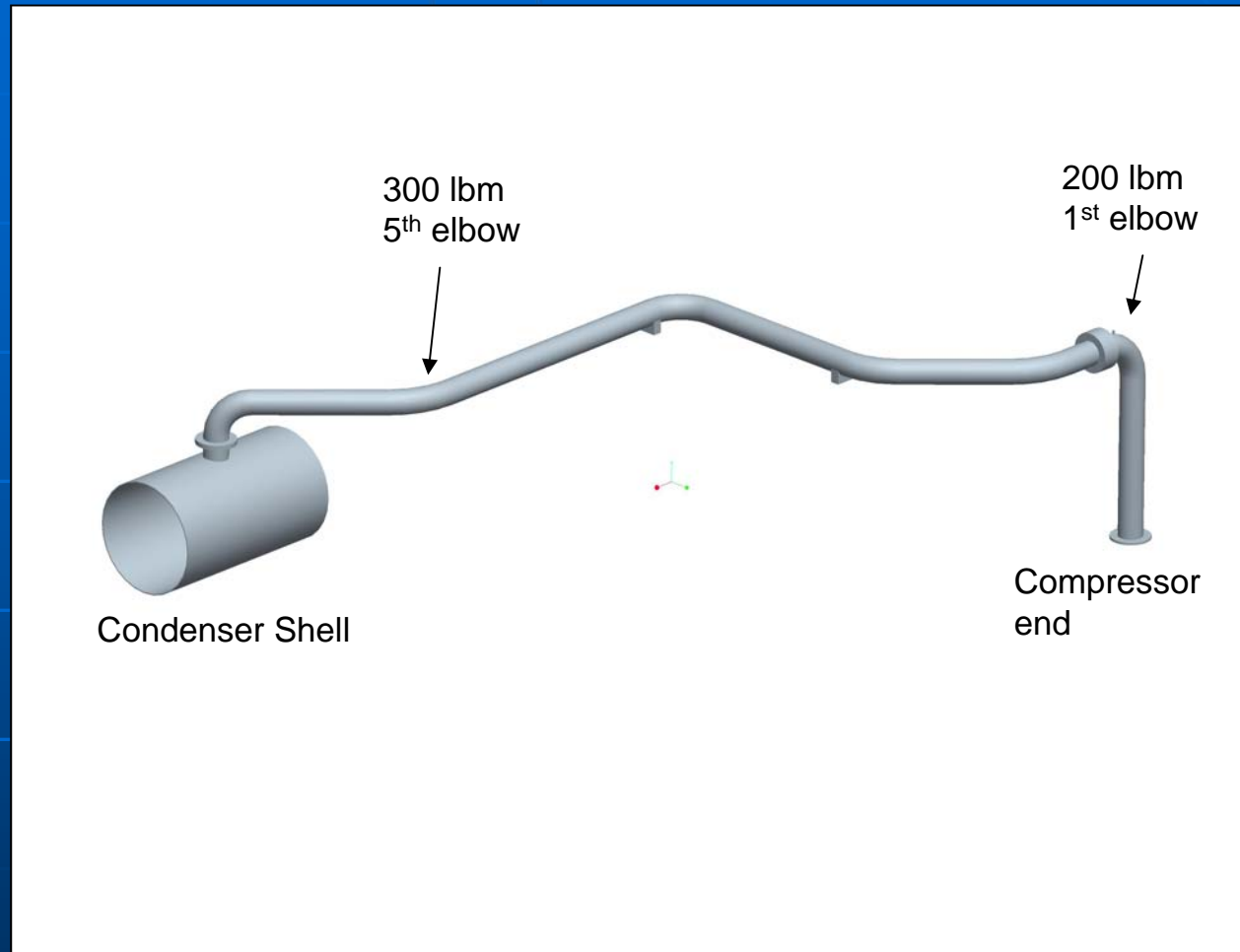

- Piping vibration amplitude was reduced from 1.6 in/s pk to 0.38 in/s pk @ 19 Hz

CASE 3

Exciter's Enclosure Vibration at the Running Speed of the Turbine-Generator

Problem Statement

- Excessive vibration on the Exciter's enclosure of a 1300 MW Nuclear Power Generation main unit.
- Nearly 1.0 in/s peak vibration level was detected at the buss-bars' support in the axial direction of the unit at the running speed of 30 Hz (1800 cpm).
- Vibration level was jeopardizing the internal structure that supported the buss-bars.



ODS Animations

- Evident looseness of the entire enclosure was detected with the ODS at the running speed of the unit.
- A natural frequency of the enclosure was tuned-in with the 1x running speed of the unit as a consequence of looseness of the enclosure relative to the foundation floor.

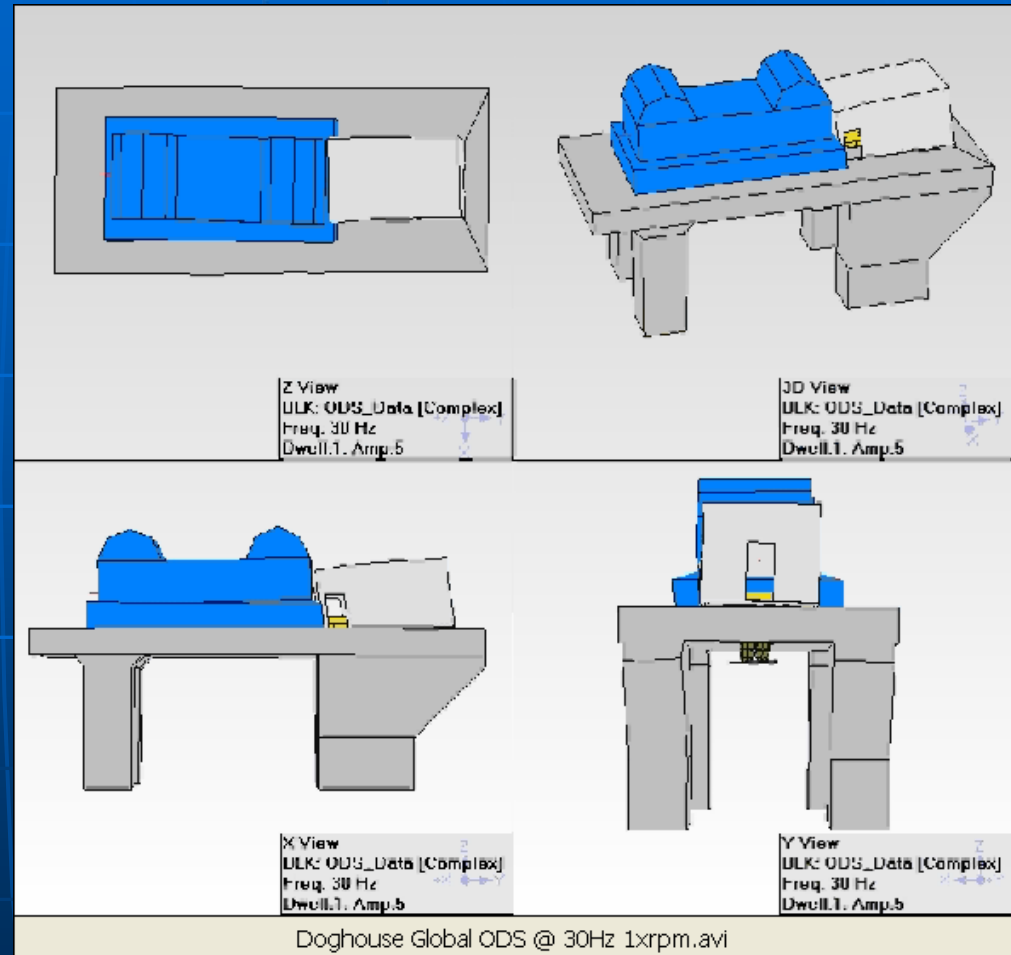

ODS Animations

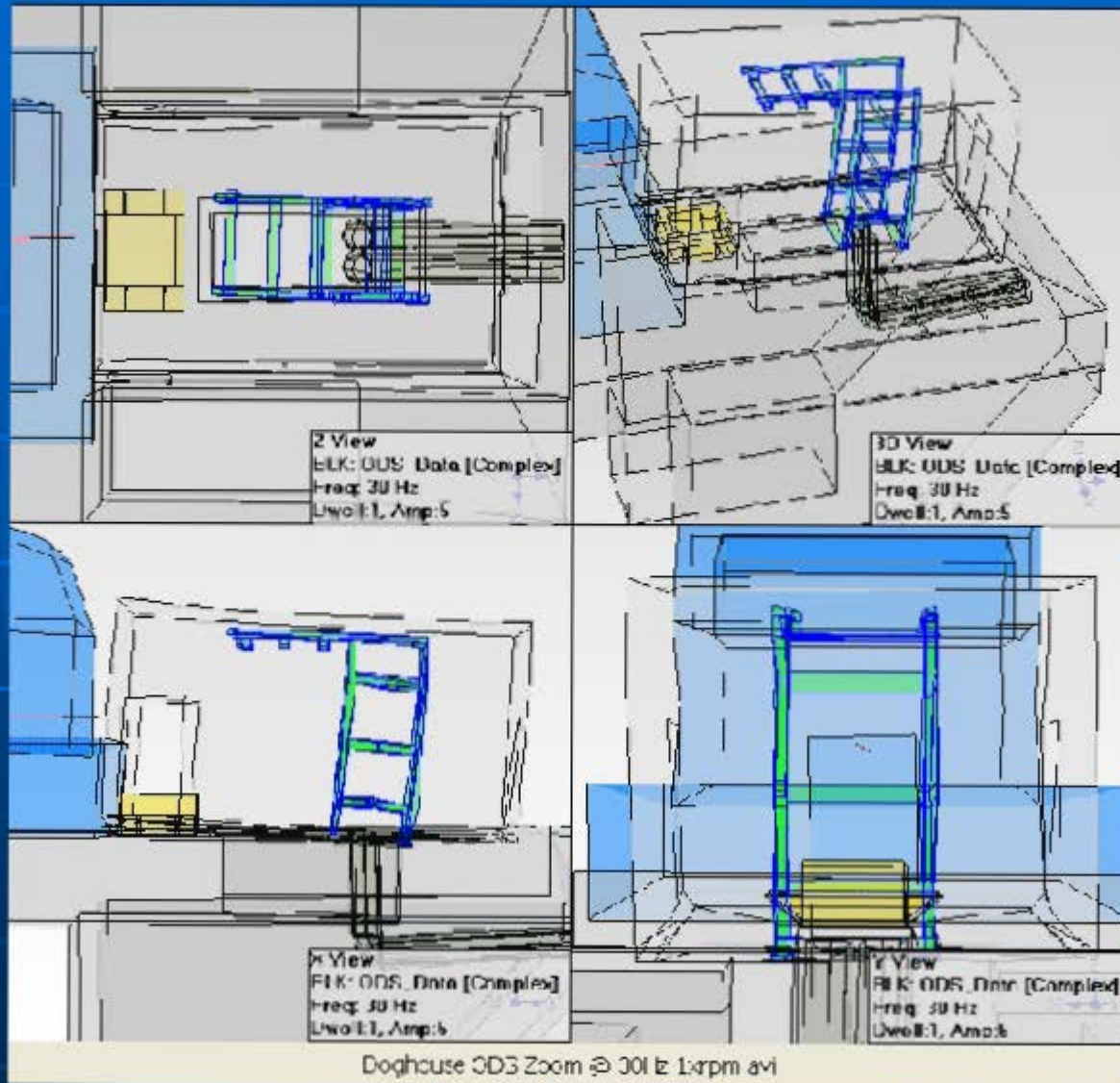

CASE 4

Aero-derivative Gas Turbine Engine Vibration

Problem Statement

- **Relatively high vibration was reported on a gas turbine engine rated at 22 MW at a pharmaceutical power generation plant.**
- **Vibration amplitude of 6.0 mils pk-pk of was detected at the compressor section of the engine at the gas generator rotor speed of 154 Hz (9240 rpm).**

ODS Animations

- ODS test analysis indicated a mechanic or aerodynamic imbalance of the gas generator rotor.
- The ODS also revealed potential looseness of the baseplate and excessive flexibility of one of the engine's supports.

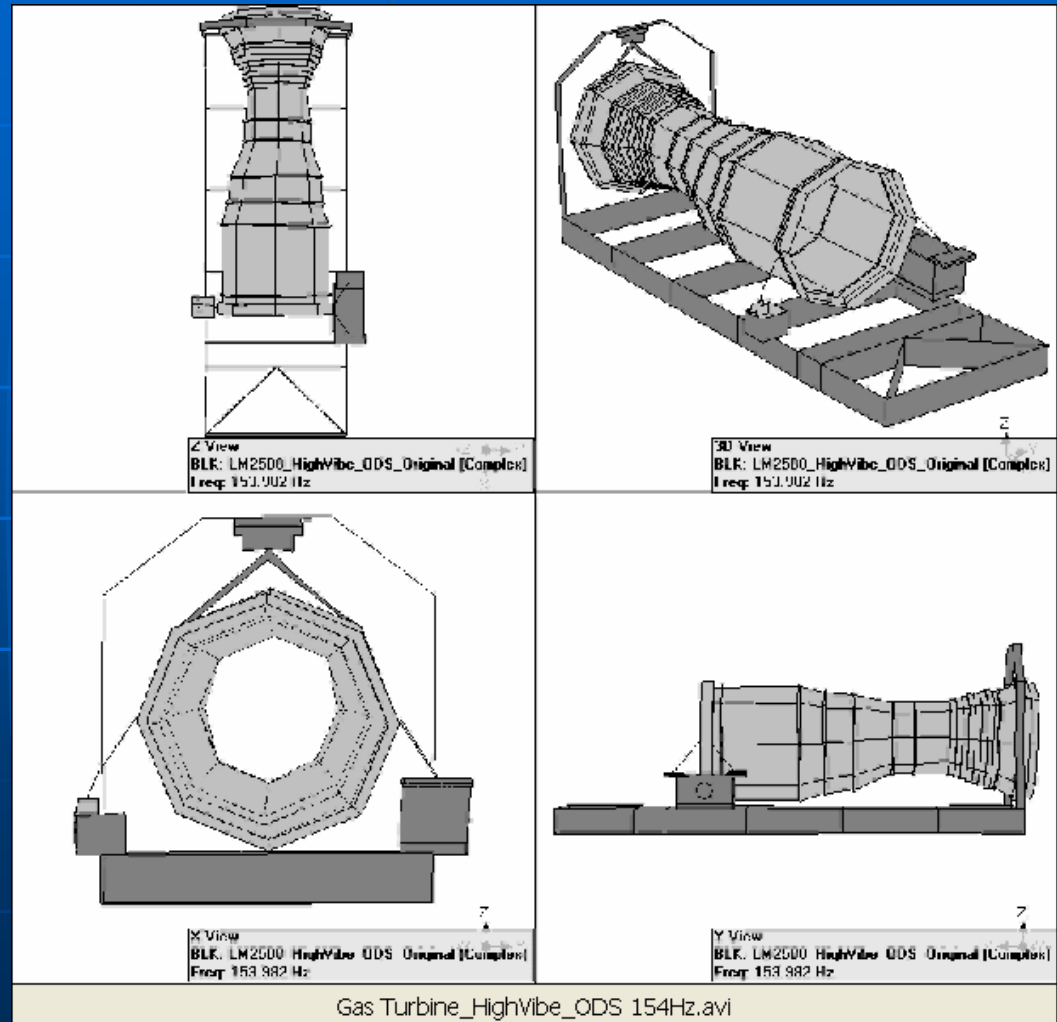

ODS Animations

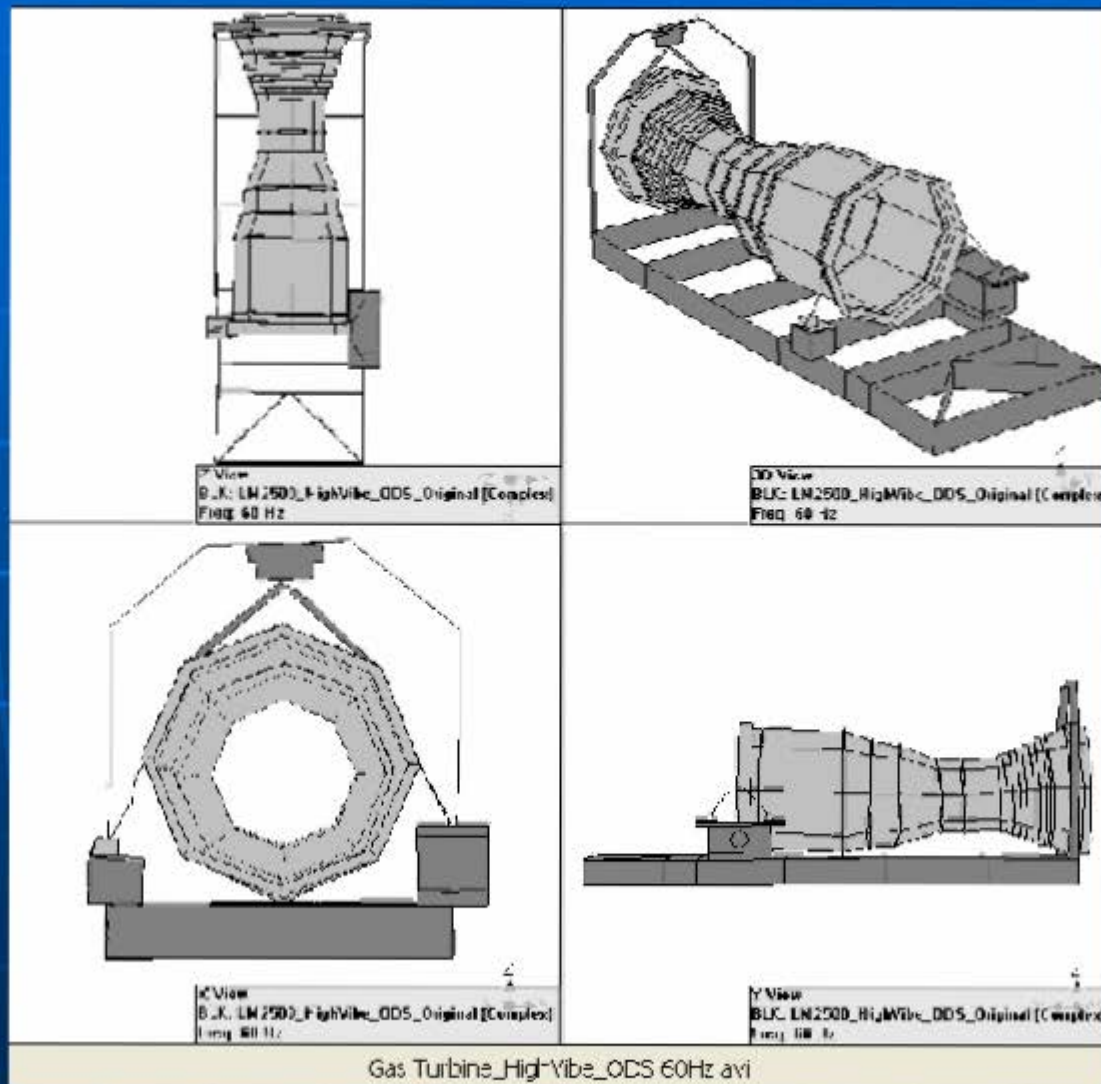

CASE 5

FD Fan Excessive Synchronous Vibration of the Entire Structure

Problem Statement

- The vibration of a FD Fan in a Paper Mill facility was reported to be very sensitive to the balancing of the rotor with frequent on-site balancing performed by the End User.
- Vibration levels were measured to be low during the test due to recent major maintenance of the unit.



ODS Animation at the Running Speed

- Excessive looseness of the entire fan housing detected with the ODS at the running speed of the unit.

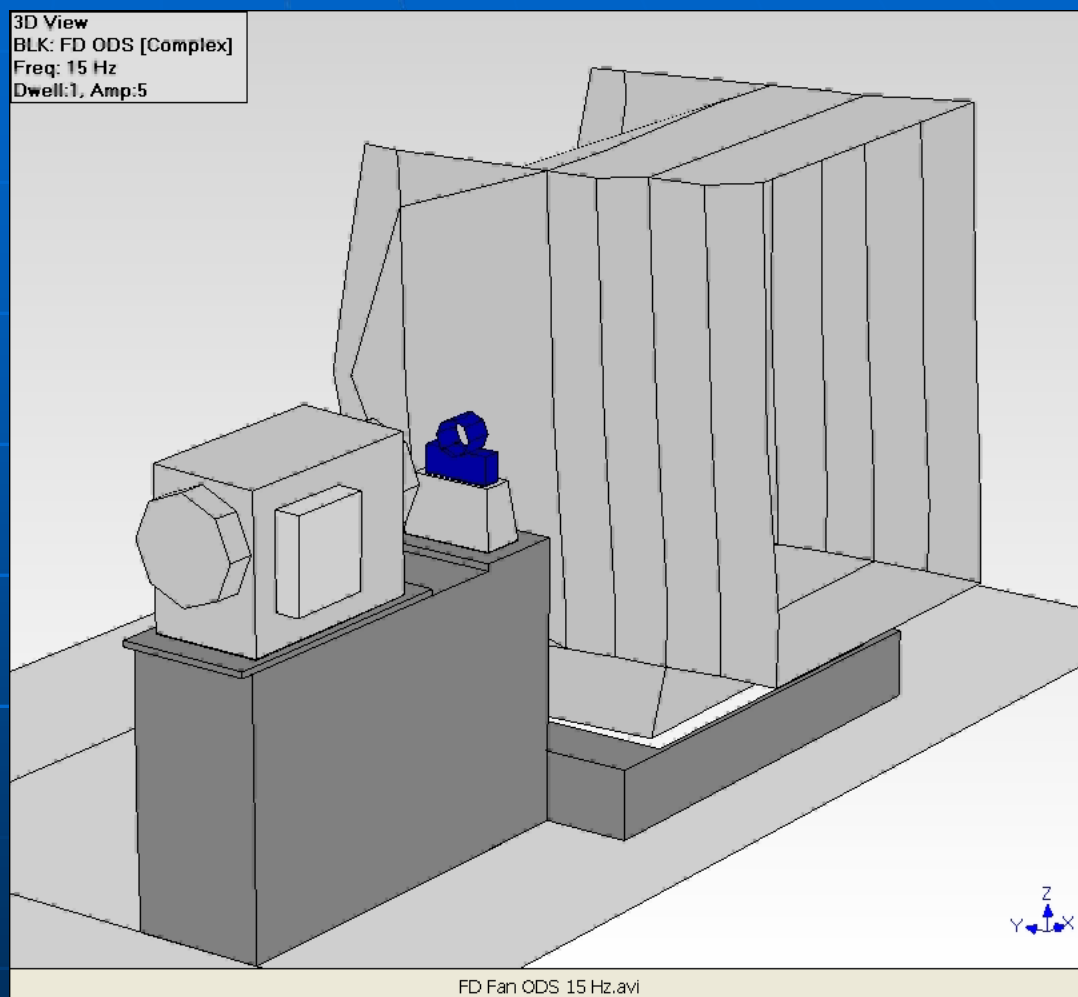

CASE 6

Exciter Vibration in a Nuclear Power Plant

Problem Statement

- A 1200 MW Steam Turbine-Generator Exciter presented high vibration level at the running speed (1800 RPM).
- At 1x RPM, the highest vibration at the inboard bearing housing was above 0.40 in/s in the horizontal direction.
- Vibration level incremented gradually after major outage in 2002.



ODS Animation at the Running Speed

- Significant soft-foot condition detected in the opposite south-west and north-east corners between the exciter casing and its base-plate.

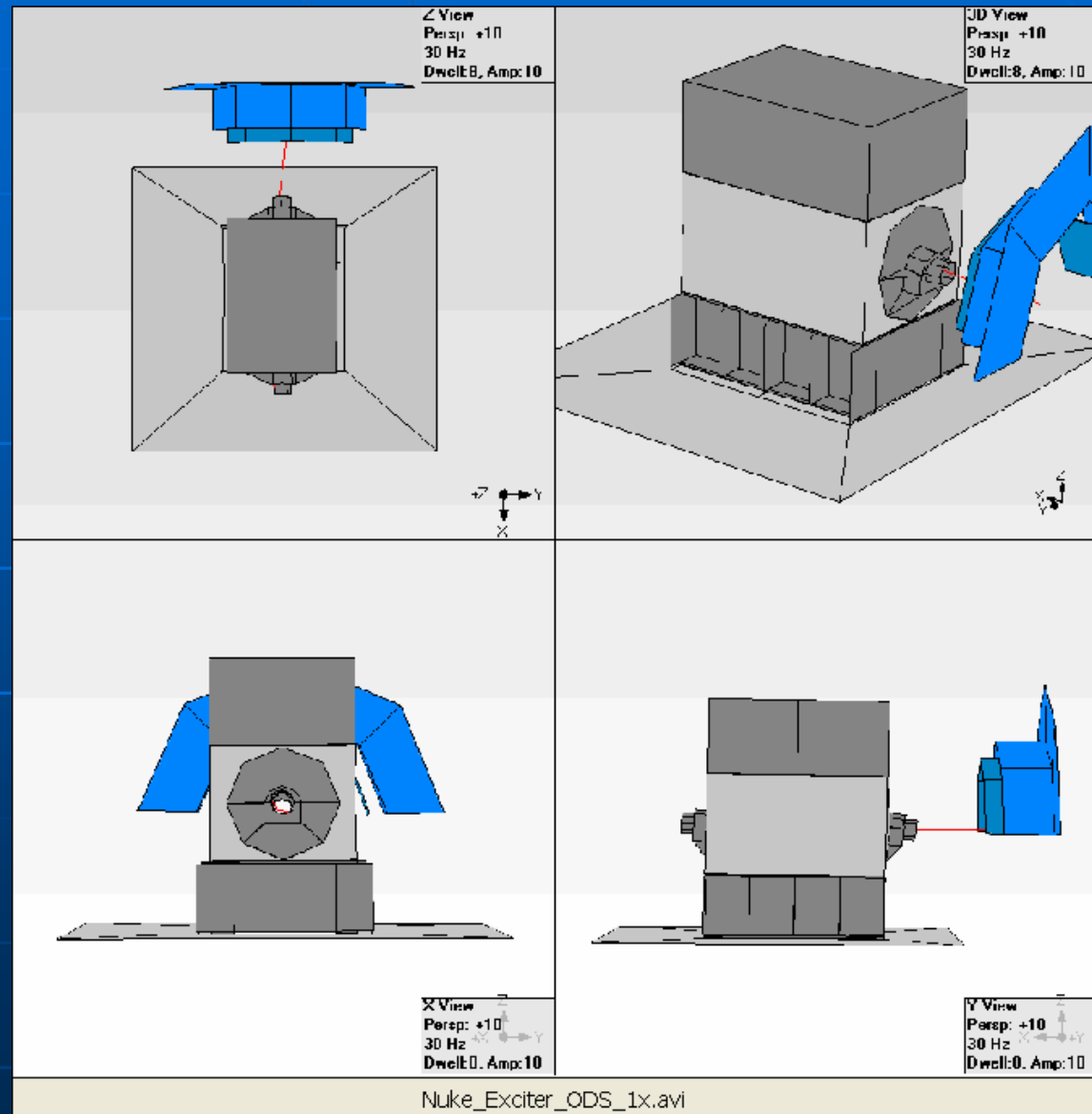

CASE 7

ID Fan Excessive Synchronous Vibration

Problem Statement

- High vibration on two newly installed double suction ID Fans, rated 7000 HP, in a fossil power plant (450 MW) driven by constant speed electric motors at 895 RPM (14.9 Hz).
- The largest vibration amplitude measured was 0.46 in/s peak measured at the running speed in the horizontal direction of the OB bearing housing.

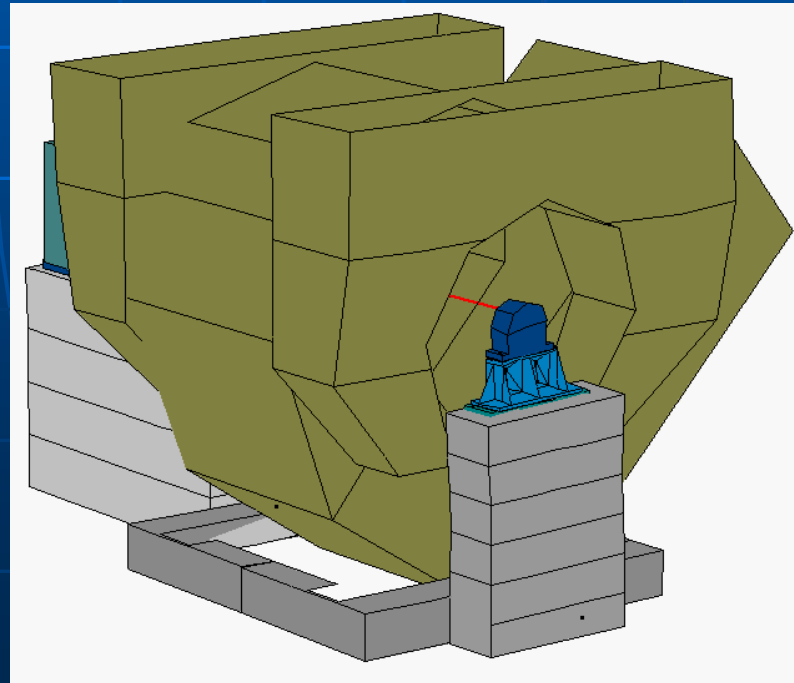

ODS Animation at the Running Speed

- Rocking motion of the outboard concrete pedestal as a rigid body at the running speed.
- Looseness of the bearing assembly and bearing support and its soleplate.

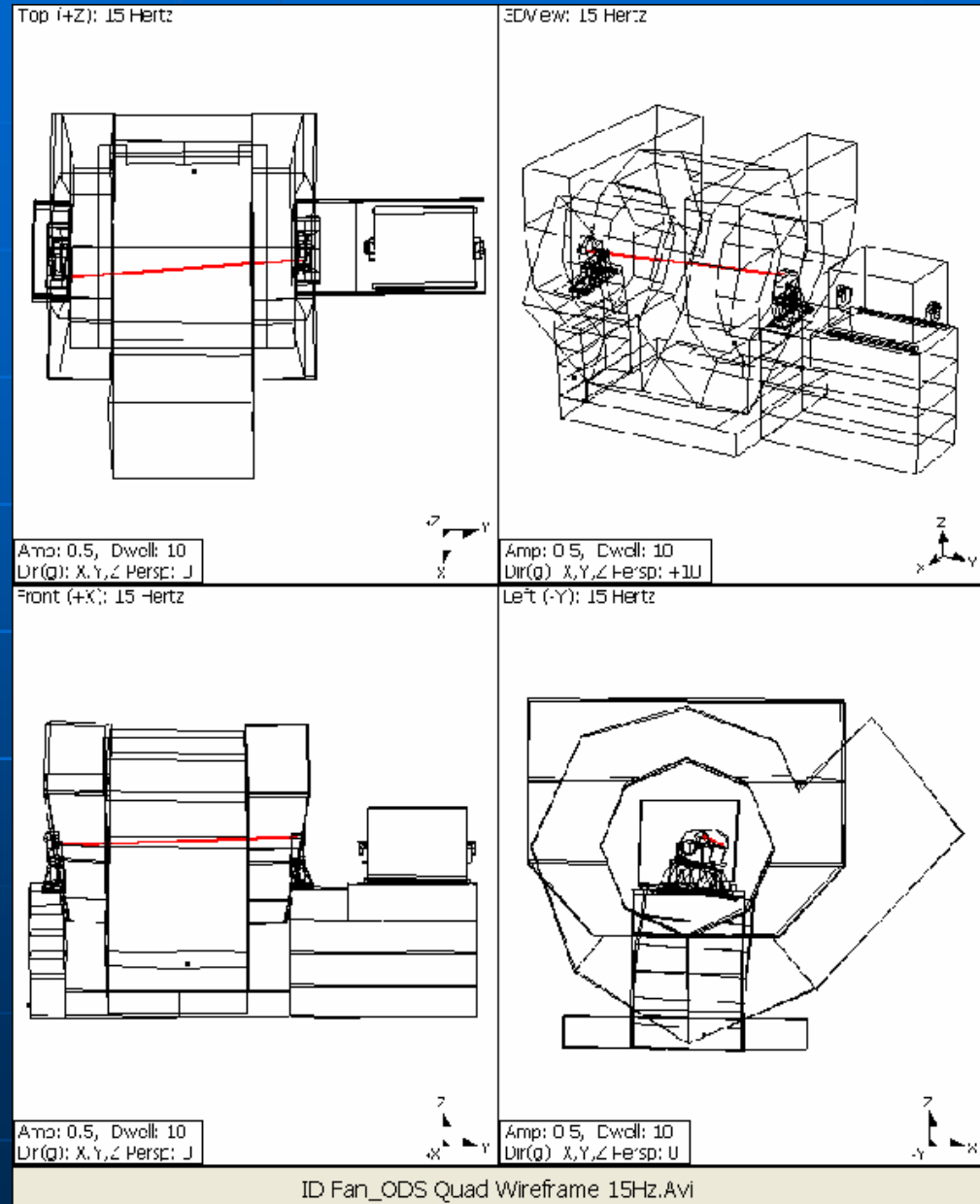

ODS Animation at the Running Speed

- Looseness of the bearing assembly and bearing support and its soleplate.

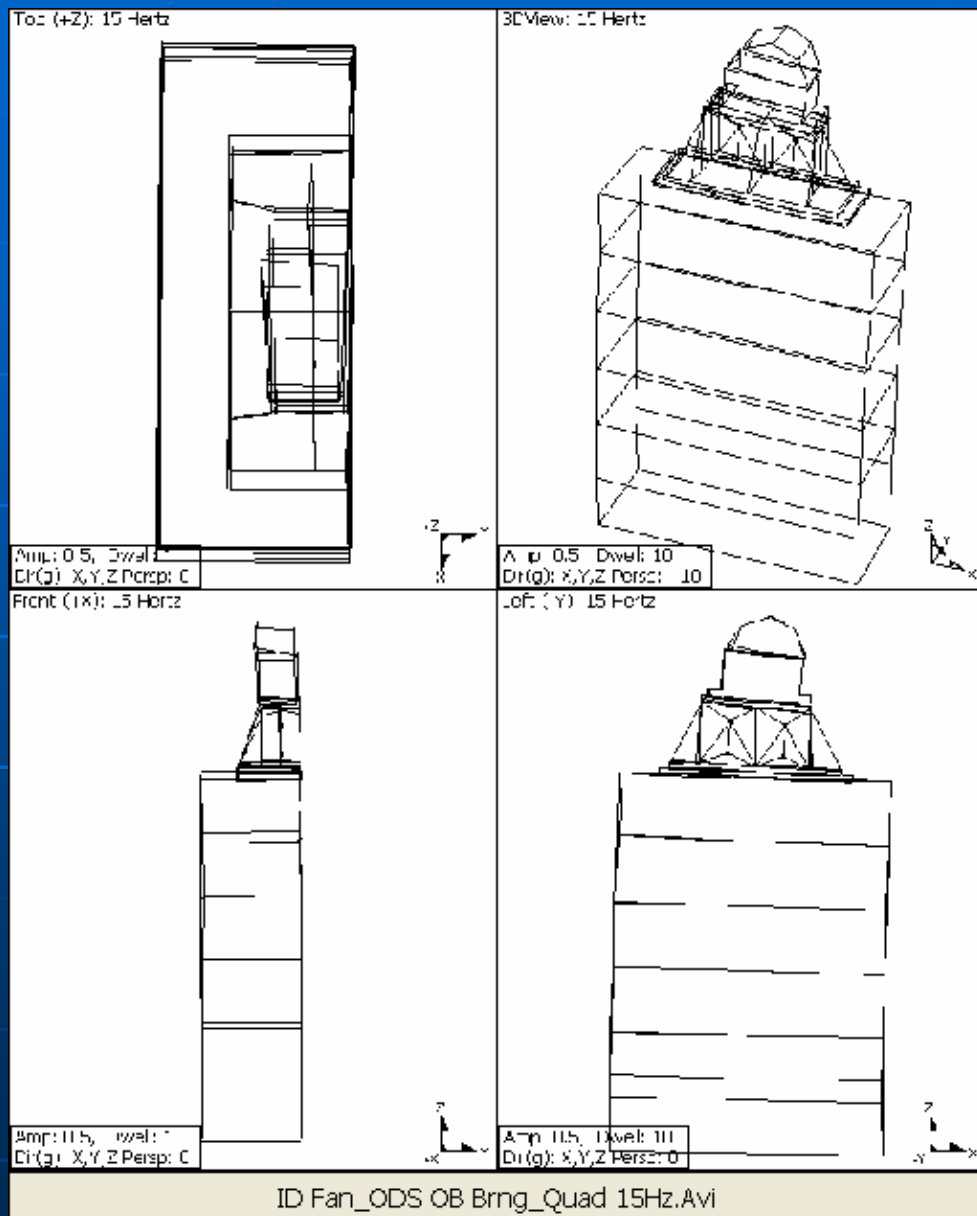

Conclusions

Conclusions

- **The ODS is a powerful troubleshooting tool to facilitate and visually understand most common vibration problems in any Turbomachine. Animations created from the ODS test data show exaggerated motion (but consistently scaled) of operating machinery at any given frequency.**
- **Typical vibration analysis and pursuing trial and error correction methods can be time consuming, cumulatively costly, and do not always achieve the long-term trouble-free operation which is sought.**
- **In most of the cases, the ODS analysis provides enough diagnostic information to identify and solve the problem.**
- **Combined with modal “bump” testing during operation, ODS becomes even more powerful.**

Recommendations

- Detailed vibration data should be taken when performing an ODS capturing all flange-to-flange interface areas between assembly parts, flexible components, supports, concrete foundation, etc.
- In particularly difficult cases, a combination of vibration testing and finite element analysis has proven to be valuable in diagnosing vibration problems and determining practical solutions.

Thank you
Any Questions...?