

Case Study – Load Dependent Critical Speed

39th Turbomachinery Symposium
October 7, 2010

Mr. Gregory L. Elliott
Senior Project Engr.
Lufkin Industries, Inc.



Mr. James F. McCraw
Rotating Equipment Engr.
BP America, Inc.



Mr. Thomas P. Shoup
Chief Engr., Operations Mgr.
Lufkin-RMT



Problem Statement

- Machinery train in natural gas processing facility
 - 5750 HP (4287 kW) synchronous motor at 1800 RPM.
 - Speed increasing gear drive.
 - Centrifugal compressor at 14620 RPM.
- Over-torque event after fifteen years of operation
 - Sheared bolts in LSP coupling.
 - Raised questions about gear rotating elements.
- Gearbox refurbishment and shop test
 - Time was critical.
 - Spare rotating elements used.
 - Unrelated HS bearing issue – replacement required.
 - Changed HS bearing design due to long delivery time of original design.
- After refurb, tripped on HS pinion vibration at startup.

Low Speed Coupling With Elastomer Inserts

- Coupling bolts sheared; most likely cause improper restart.
- Gearbox refurbishment requested.

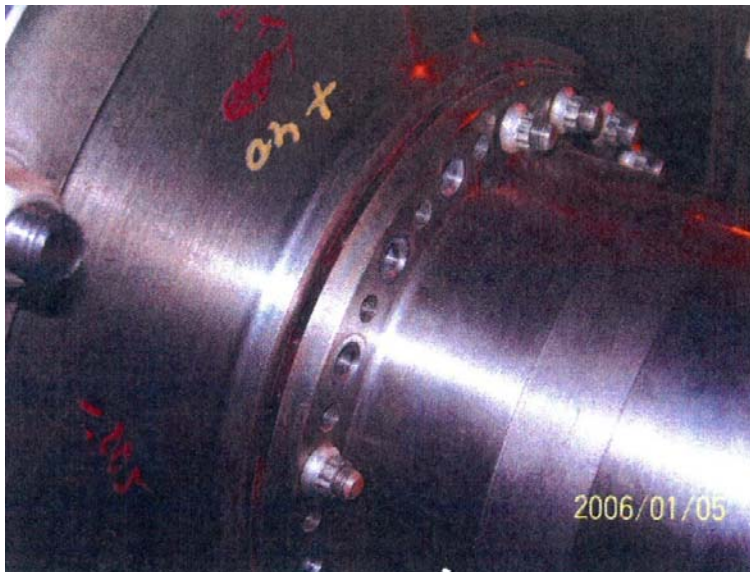
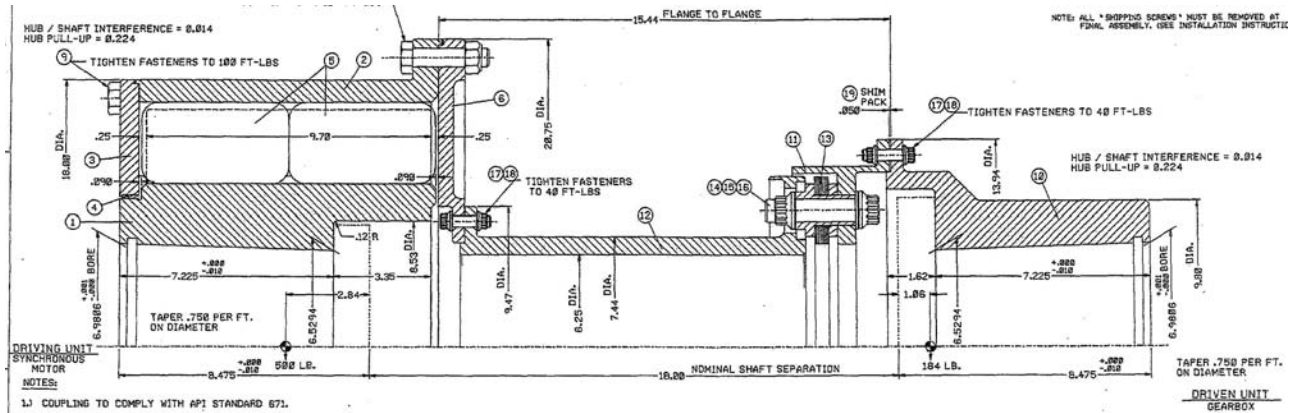

Gearbox Description

- Single stage, 8.1:1 ratio speed increaser
- Shaft center distance 24 inches (610 mm)
- Double helical gearing
- Fabricated steel casing
- Tilting pad HS pinion radial bearings

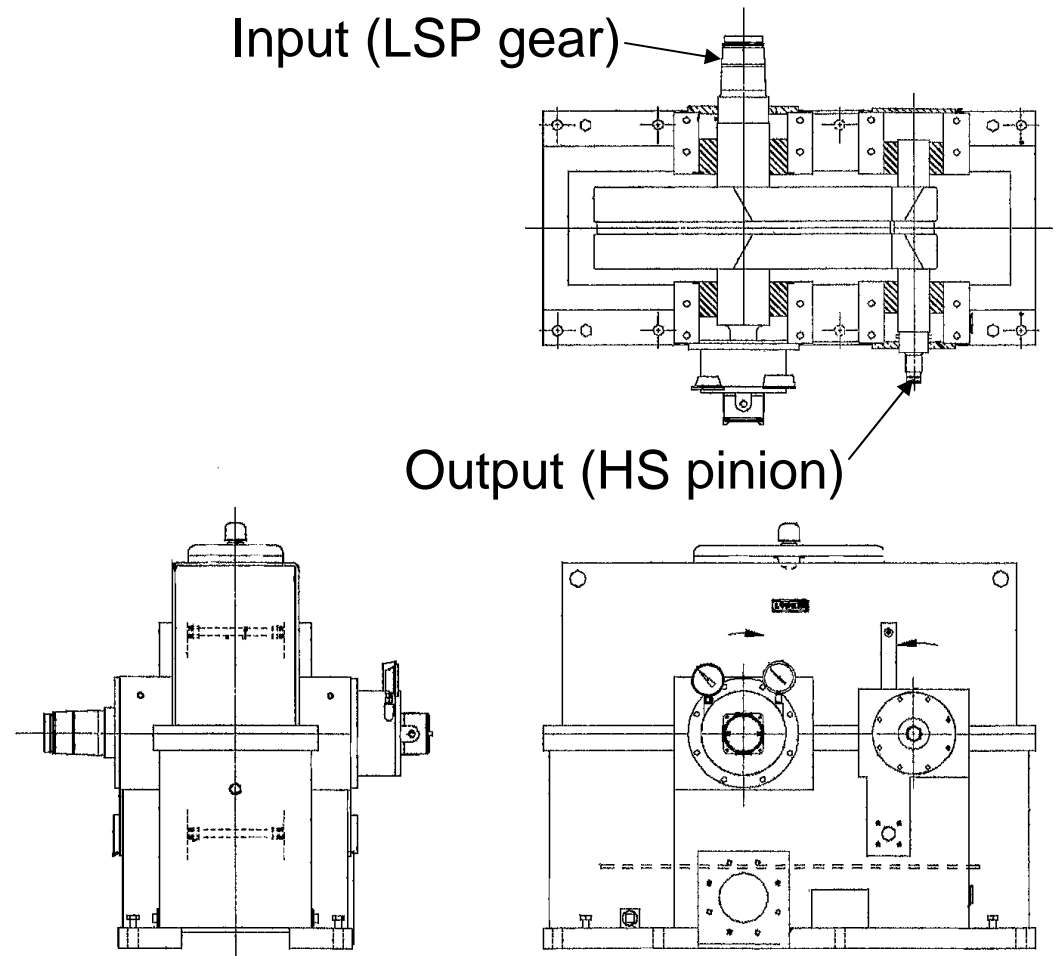

Vibration After Gearbox Refurbishment

- Could get up to speed (initially, no load).
- HS pinion vibration increased with compressor discharge pressure.
- Tripped on HS pinion shaft radial displacement before reaching full load.
- Parallel solution process:
 - Review original design.
 - Simulate analytically.
 - Implement changes in gearbox.

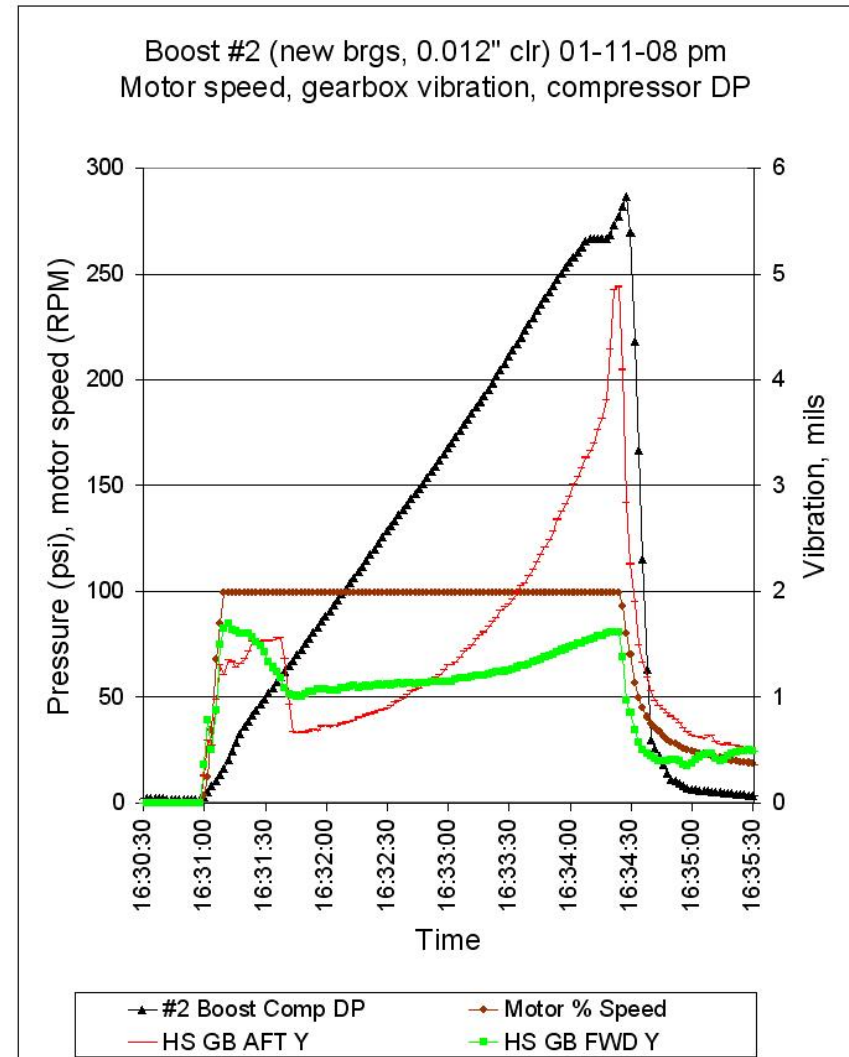

Review of Original Design and Operation

- Condition existed in original design:
 - Calculated natural freq. below running speed at low load.
 - Above running speed at full load.
- Operating data showed pinion vibration problem before refurbishment.
- Amplitude before refurb lower than after refurb; reasons not fully understood.

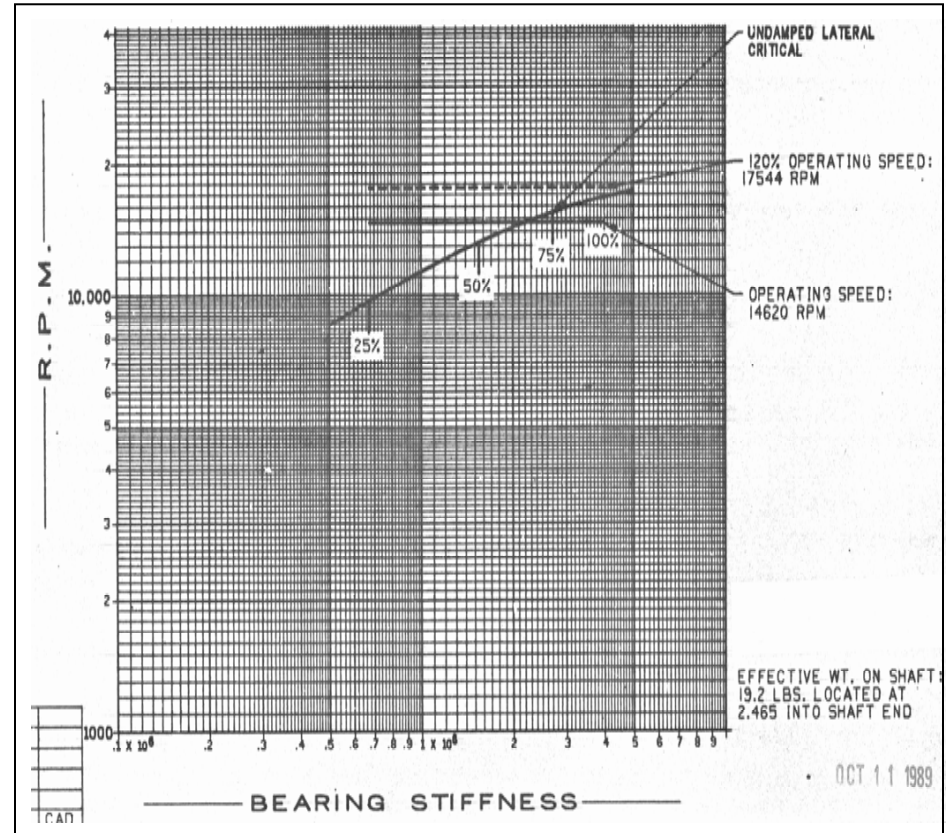

Effect of Load on HS Pinion Bearings

- Gear mesh force proportional to torque
 - Mesh is main bearing load.
 - Low torque = soft bearings.
 - High torque = stiff bearings.
- Operating speed 14620 RPM.
- Calculated critical speed changes with load
 - 13800 RPM at low load.
 - 17100 RPM at full load.
- As machine is loaded critical speed moves from below to above operating speed.

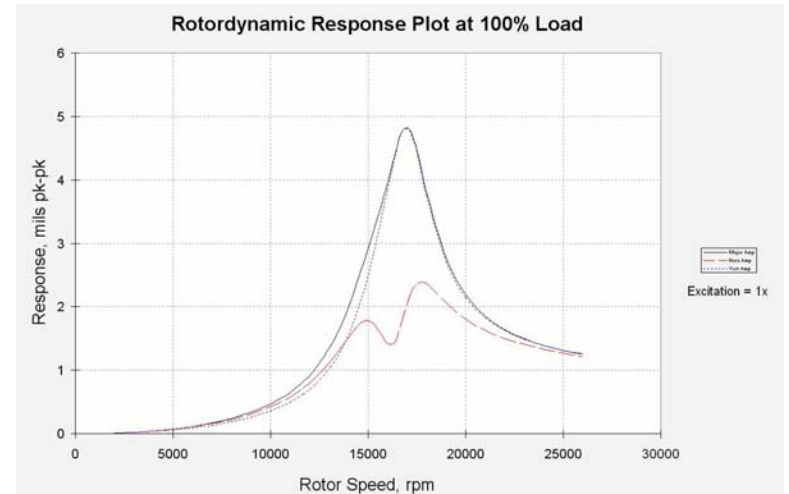
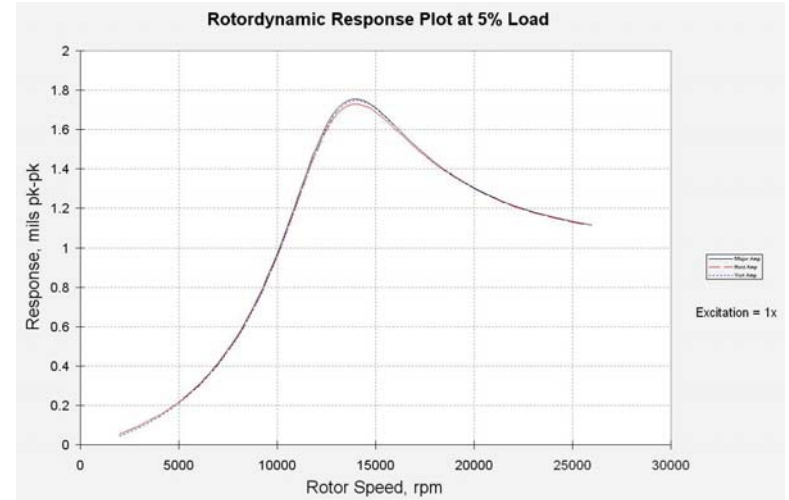

Evaluated Load and Bearing Clearance

- Possibly other system issues, but focus was on gearbox.
- Changed bearing clearance
 - Relatively quick and easy to do (removable pad seats).
 - Affected bearing stiffness at low to medium load.
- Machine still tripped; during loading with medium & loose bearings; at motor start with tight bearings (higher stiffness).
- Field & analytical results were generally consistent.
- Changing bearing clearance was not the solution.

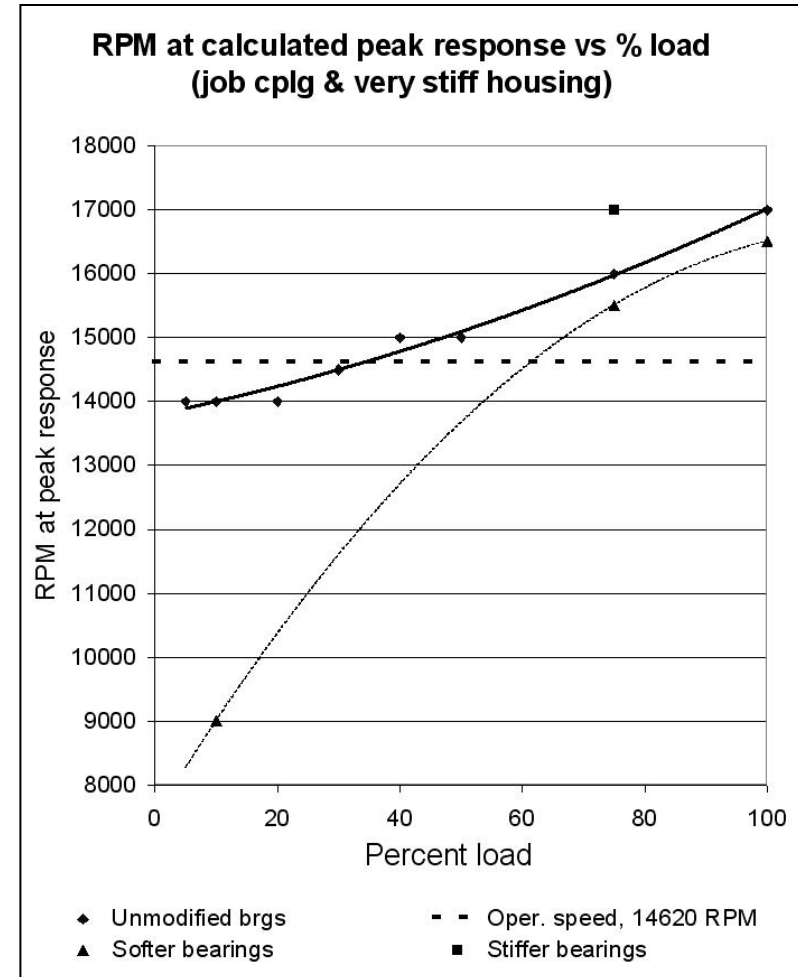

Reviewed Rotor-Bearing Layout

- Substantial change was needed
- HS coupling half CG location was relatively far from the drive end bearing.
- Moving the drive end bearing toward the shaft end should make a significant improvement in the rotor-bearing system behavior. For example, the critical speed should move up in frequency.
- Oil supply passages in gear housing could not be moved without machining housing – not a good option.

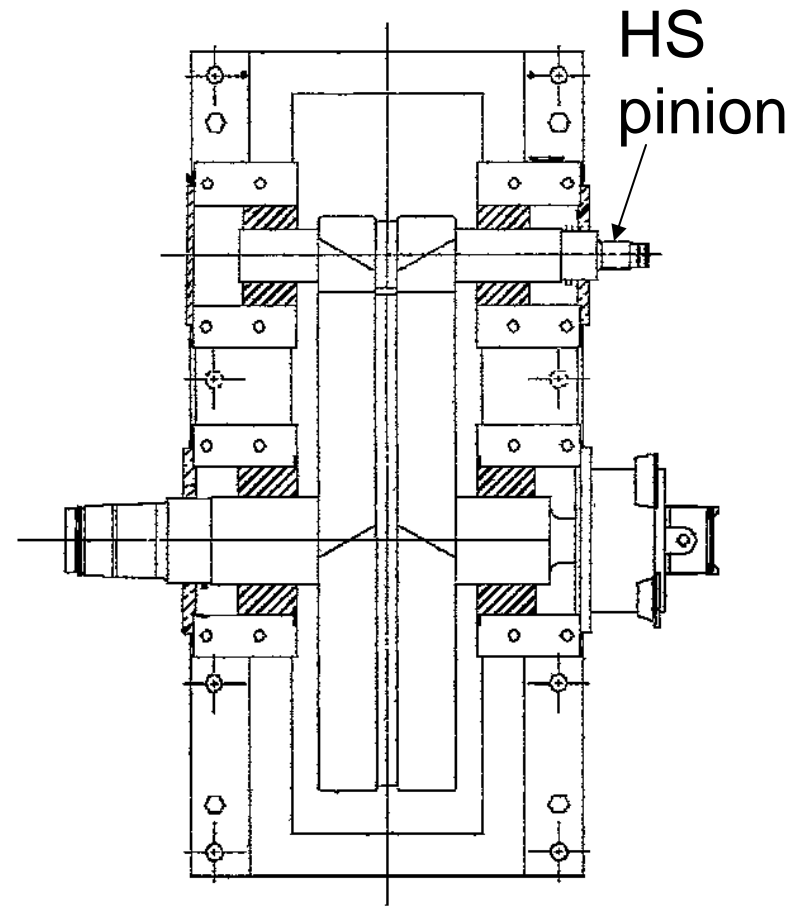

Relocating HS Pinion Bearing Pads

- Extended bearing shell toward the shaft end as shown in red.
- New shell moves the bearing pad centerline outward while using the original gear housing oil passages.
- New shell could be produced quickly.
- Pinion drive end bearing only.
- Moved bearing centerline 2.5 inches (63 mm) closer to HS pinion shaft end.
- Improved rotordynamics.

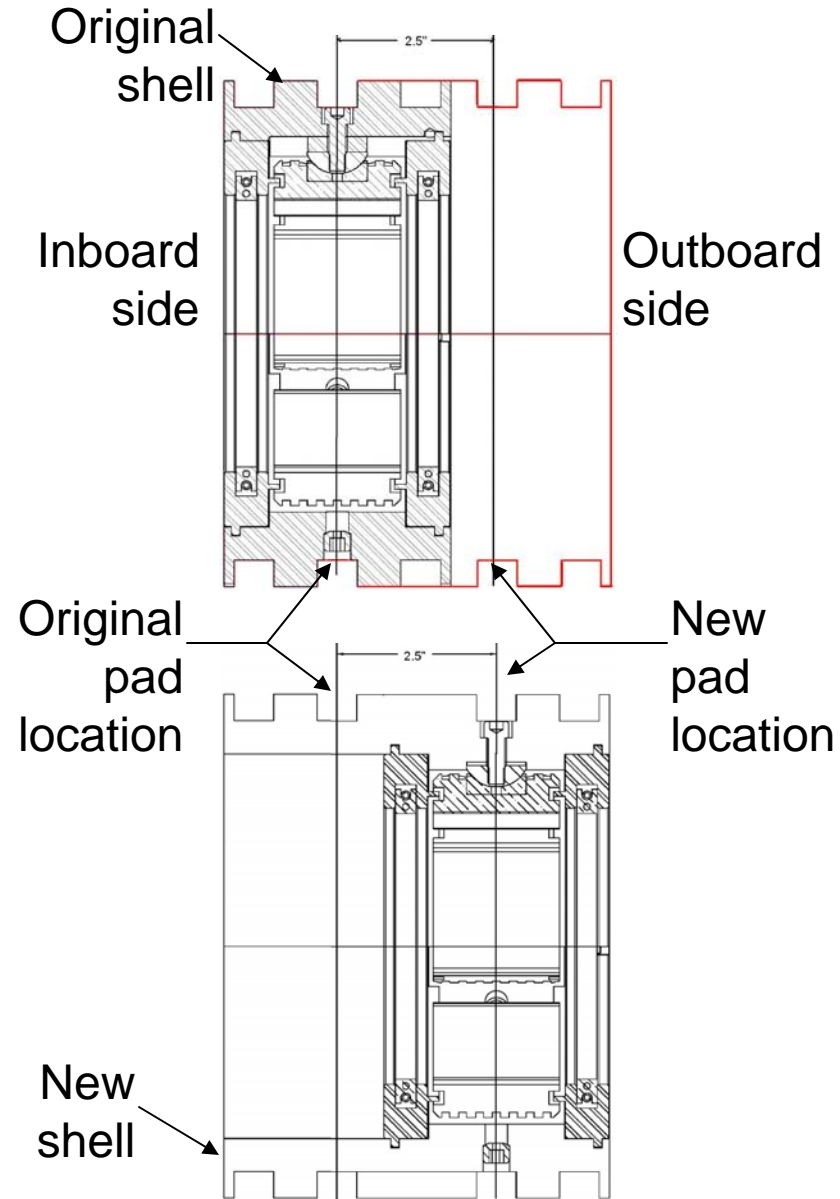

Undamped Mode Shape

- Overhung coupling weight at shaft end has strong effect.
- Moving drive end bearing closer to shaft end is beneficial.

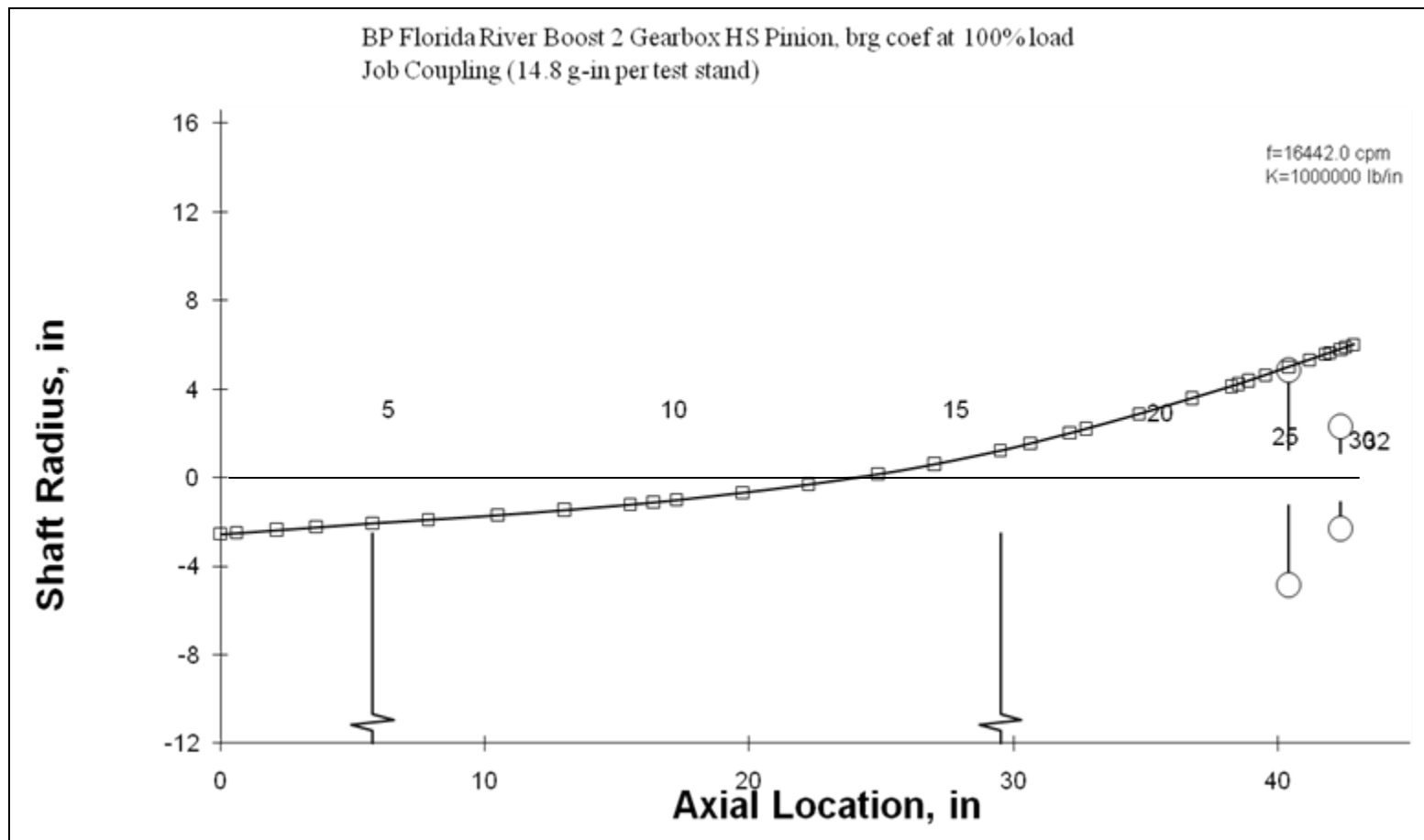

Critical Speed Map

Undamped critical speeds are higher with bearing moved nearer to overhung weight at shaft end

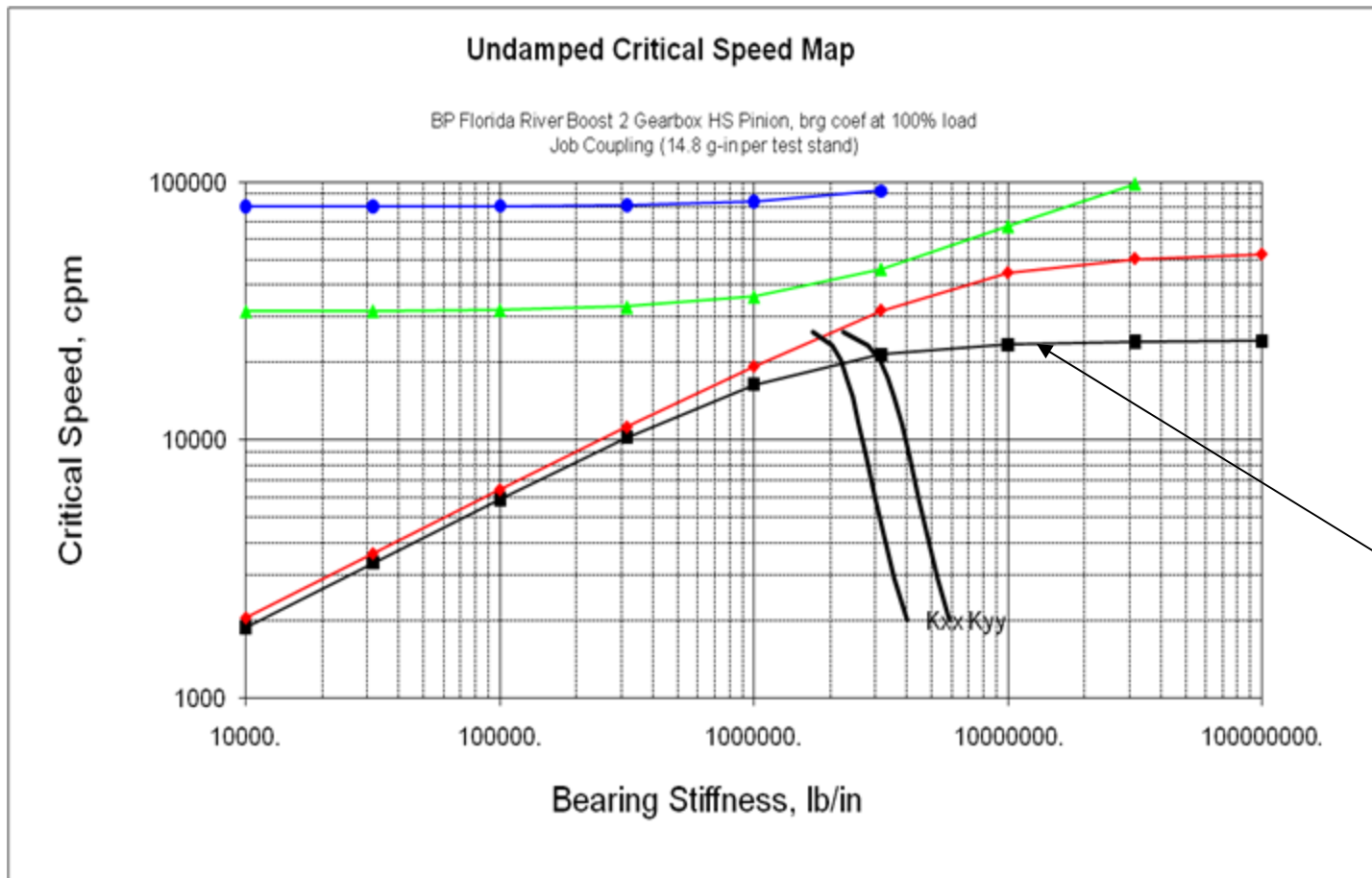

Re: mode
shape plot

Predicted Effect of Moving Pinion Bearing – Low Load

Natural frequency still low at low load – but now well damped.

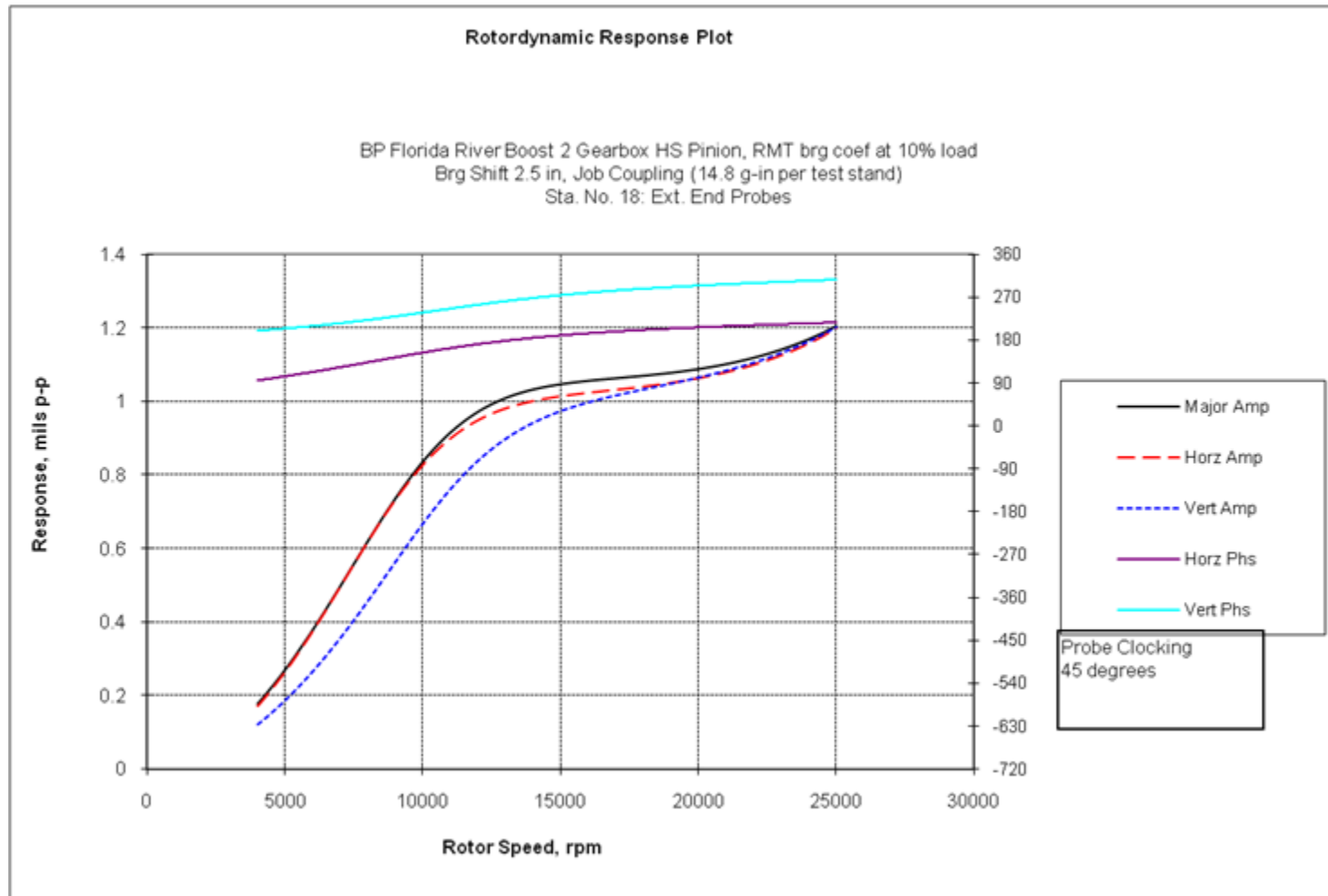

Predicted Effect of Moving Pinion Bearing – Full Load

Critical speed moved up at full load, 17100 to 19850 CPM.

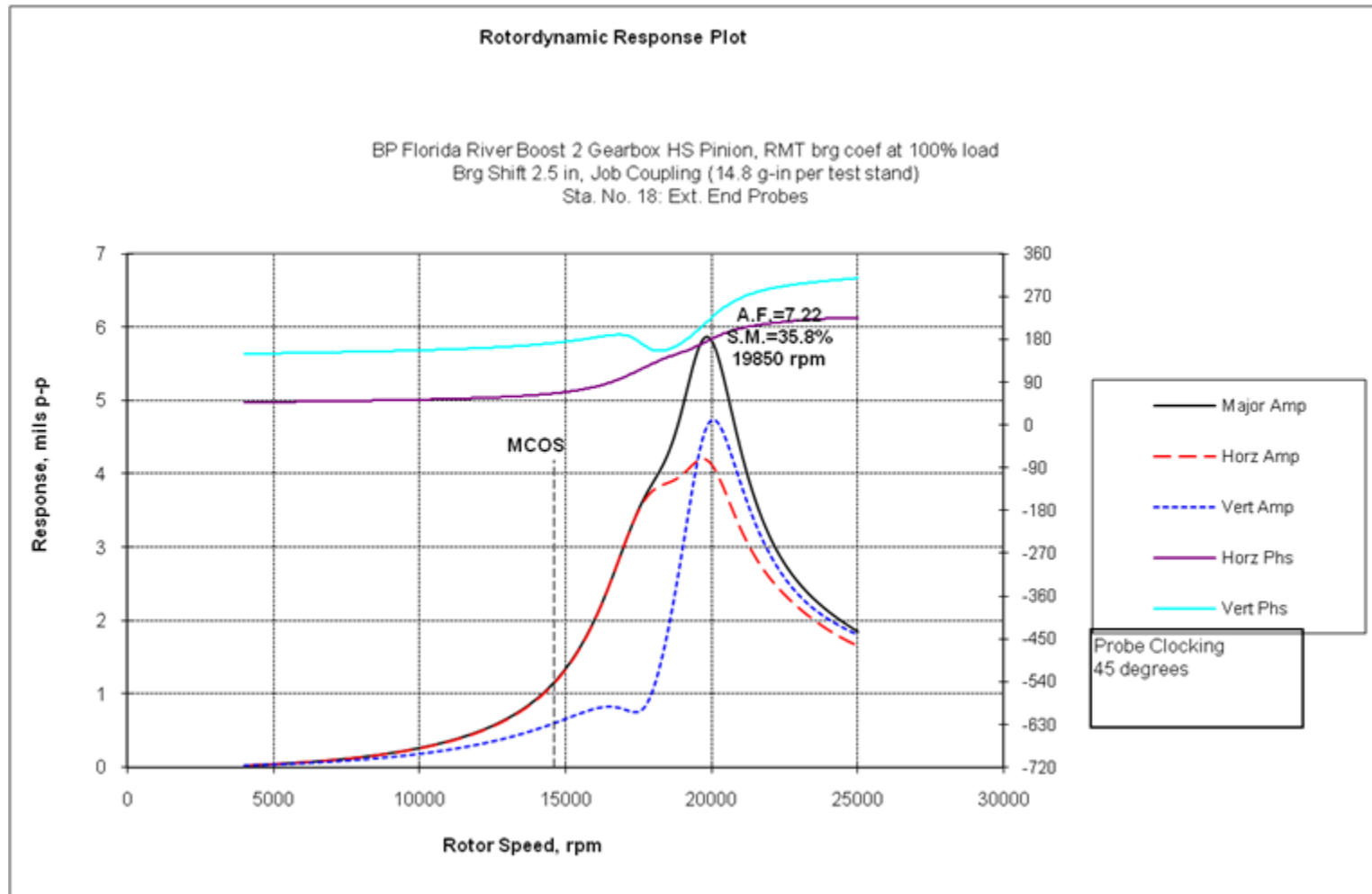

Field Results of Moving Pinion Bearing

- No problem during startup, about 0.001” (0.025 mm) shaft radial displacement was worst HS pinion vibration observed.
- Pinion running about 0.0003-0.0004” (0.008-0.010 mm) at load.
- Gearbox robust enough to resist possible alignment or compressor problems.
- The machine now runs better than it did before the refurbishment.
- Good performance in more than two years operation since fix.

Conclusions

- HS pinion lateral critical speed with frequency varying with load, crossed operating speed as load increased, resulting in a trip as the machine was loaded.
- Vibration already present before refurbishment increased due to slight change in bearing properties, rotor balance, alignment, or behavior of a connected machine; otherwise behavior was similar before bearing was relocated.
- Adjusting bearing clearance to change rotor-bearing system behavior was insufficient to solve the problem.
- Relocating the HS pinion drive end bearing closer to the shaft end significantly improved rotordynamics and solved the problem.
- As a result of the changes the machine was more robust than it was as originally designed and built.

Lessons Learned

- “Simple” refurbishments may not be as simple as they seem
 - There may be an existing problem that was worked around in previous operation.
 - Unknown unbalance, temperature, alignment, or other system conditions can be enough to trigger unexpected results.
 - Original design and operating data should be reviewed.
- A time will come when it’s necessary to do what it takes to get on with life
 - Operators understandably don’t like “research projects” that interfere with production.
 - Something that normally should work may have to be abandoned.
 - To use a basketball analogy, one must go for the slam dunk.
 - In this case the slam dunk was to move a bearing.

Questions?