



RANGE VERSUS EFFICIENCY – STRIKING THE PROPER BALANCE

James M. Sorokes
Principal Engineer
Dresser-Rand
Olean, N.Y.



James M. “Jim” Sorokes is a Principal Engineer at Dresser-Rand with over 36 years of experience in the turbomachinery industry. Jim joined Dresser-Clark (now Dresser-Rand) after graduating from St. Bonaventure University in 1976. He spent 28 years in the Aerodynamics Group, became the Supervisor of Aerodynamics in 1984

and was promoted to Manager of Aero/Thermo Design Engineering in 2001. While in the Aerodynamics Group, his primary responsibilities included the development, design, and analysis of all aerodynamic components of centrifugal compressors. In 2004, Jim was named Manager of Development Engineering whereupon he became involved in all aspects of new product development and product upgrades. In 2005, Jim was promoted to principal engineer responsible for various projects related to compressor development and testing. He is also heavily involved in mentoring and training in the field of aerodynamic design, analysis, and testing.

Jim is a member of AIAA, ASME, and the ASME Turbomachinery Committee. He has authored or co-authored over forty technical papers and has instructed seminars and tutorials at Texas A&M and Dresser-Rand. He currently holds three U.S. patents and has give others patents pending. He was elected an ASME Fellow in 2008.

ABSTRACT

The paper addresses the balance between peak attainable efficiency and overall operating range that must be addressed when specifying, designing and/or selecting centrifugal compressors. The relative roles of the various compressor components; i.e., impellers, diffusers, guide vanes, and return channels; in achieving the proper balance are discussed. Finally, the importance of proper component and stage aerodynamic matching is emphasized.

INTRODUCTION

Two of the most important considerations in centrifugal compressor performance are efficiency and overall flow or operating range. A compressor’s efficiency has a direct impact on the power requirement for the process because higher efficiency yields lower power consumption or allows more product to be made for a given amount of energy input. The

overall flow range limits the compressor’s ability to operate at other than the design condition; i.e. off-design conditions.

Ideally, compression equipment would provide both high peak efficiency and wide overall operating range. Unfortunately, efficiency and flow range are quite often mutually opposing forces in the real world. The very features that contribute to high peak efficiency (*i.e.*, vaned diffusers) can and do cause a reduction in overall operating range. Likewise, the design approaches used to obtain wide operating flow range typically do not provide the maximum achievable peak efficiency levels. As a result, the designer must determine the proper balance between overall flow range and peak efficiency when developing new stages and/or specifying components for a compressor application. This paper is discusses the factors that must be considering in striking this balance in industrial centrifugal compressors.

The paper briefly describes the parameters commonly used to assess flow range and efficiency of centrifugal turbomachinery. This paper touches on the impact of range and efficiency on machine cost. That is, it might be possible to maximize both range and efficiency but only via non-standard components that add to the complexity and, therefore, the cost of the equipment. However, in some applications, the additional range provided might justify the added expense. For example, if by providing additional range, a bundle change-out can be avoided, the additional upfront cost of the compressor might be offset by the reduction in long-term costs that would result from the bundle changes, production interruptions, and other related expenses.

The paper also provides insight into the design choices made by manufacturers of industrial turbo-compressors. The cost to build the compressor and/or other manufacturing concerns/limitations strongly influence the design choices made by OEMs and said choices can have significant impact on equipment performance. The impact on the design philosophy for impellers, diffusers, guide vanes and other components is discussed. For example, it is common knowledge that channel vaned diffuser (*i.e.*, wedge diffusers) provide high peak efficiencies but at the expense of overall flow range. However, it is less commonly known that good flow range is possible with a wedge diffuser if the upstream impeller is designed to promote such. Also, in the past 20 years, various styles of alternate vaned diffusers have been developed that do not impact flow range assuming the upstream impeller provides a reasonable exit flow profile.

Comments are also offered on the importance of proper matching between components within a stage and stages within a compressor as well as on the influence of changes in operating conditions on the overall compressor efficiency and flow range.

CRITICAL PARAMETERS / NOMENCLATURE

Before beginning the discussion on range versus efficiency, it is important to ensure a common understanding of the nomenclature and parameters used in this paper. As a first step, the various aerodynamic components of a centrifugal (i.e., impeller, diffuser, return bend, return channel, and inlet guides) are labeled in the cross-section shown in Figure 1.

Second, the word “stage” in this paper refers to the combination of an inlet guide, an impeller, a diffuser, and a return channel (or volute). The term “section” refers to a combination of stages; i.e., more than one impeller and its associated stationary hardware. For example, the compressor shown in Figure 1 is considered to have one section but includes three stages (i.e., 3 IGVs, 3 impellers, 3 diffusers, 2 return channels, and one volute).

Next, the parameters commonly used to assess range must be understood. The first is a compressor’s design or guarantee point or points. Typically, when purchasing a new or re-rated compressor, the end user will select one or more operating conditions that are to be guaranteed by the manufacturer. The end user might indicate the most frequent or most common condition and/or might provide guidance on how often each operating condition will be used. The OEM reviews the range of conditions to be guaranteed and selects one (either the most common or some arbitrary point within the required flow range) to be the compressor’s design flow condition. This design flow condition is often where or near where the peak compressor efficiency will occur, though depending on the range requirements, the peak efficiency might occur at a higher or lower flow rate than the selected design condition. Note that when an aerodynamic engineer is developing a new stage, the design point is the flow rate at which the new component is optimized.

The flow rate is often expressed in terms of a flow coefficient. Flow coefficients come in two forms: dimensional and non-dimensional. The most widely-used dimensional flow coefficient relates the impeller’s design volumetric flow rate, Q , to its operating speed, N or Q/N . Non-dimensional flow coefficients in their various forms relate an impeller’s design volumetric flow rate, Q , its operating speed, N , and its exit diameter, D_2 . Again, the most widely used (in U.S. customary units) is:

$$\phi = 700.16 \frac{Q}{ND_2^3} \quad (1)$$

Where: Q = volumetric flow rate in cubic feet per minute

N = speed in rotations per minute (RPM)

D_2 = impeller exit diameter in inches

The flow coefficient can provide designers and end users with insight into an impeller’s configuration; i.e., axial length, basic topology, design style, etc.

A typical compressor map is shown in Figure 2. As is common practice, the flow coefficient is along the x-axis and both polytropic efficiency and head coefficient are along the y-axis. The guarantee flow condition is labeled and the new design would be developed based on this flow condition.

Two basic factors limit the overall flow range of a compressor: surge or stall margin and overload capacity. Surge or stall margin limit the compressor’s ability to operate at flow rates lower than design while overload capacity limits the ability to operate at higher rates.

A tremendous number of factors influence both surge/stall margin and overload capacity including operating speed, gas composition/characteristics, and compressor geometry. It is not the intent of this work to discuss all of these in detail but rather to introduce the limits to operating range.

The term “stability” or “aerodynamic stability” is frequently used to refer to a compressor’s surge or stall margin. This is not to be confused with “rotordynamic stability,” which assesses the mechanical aspects of the compressor. “Aerodynamic stability” is related to the quality of the aerodynamic flowfield. Typically, a very well-behaved aerodynamic flowfield will result in higher “aerodynamic stability.” That is, it will be possible to reduce the flow rate further until the flow path goes aerodynamically unstable.

“Aerodynamic stability” is typically expressed as a percentage:

$$\text{Aerodynamic Stability} = 100 - \frac{\phi_{des} - \phi_{surge/stall}}{\phi_{des}} \% \quad (2)$$

Where: ϕ_{des} = flow coefficient at design

$\phi_{surge/stall}$ = flow coefficient at surge / stall

“Aerodynamic stability” is specified along a constant speed line and reflects the flow range from design to surge/stall (see Figure 2).

The reader will note the use of the terminology “surge/stall margin.” The reason is that in most if not all cases, the useable operating range of a compressor is not limited by true surge but by some form of rotating stall. The various forms of rotating stall can cause unacceptable levels of subsynchronous radial vibration in certain portions of the performance map; typically though not exclusively the low flow portion. This then limits the overall operating range of the compressor.

“Turndown” is another parameter used to indicate a compressor’s ability to run at lower than design flow. “Turndown” is determined by tracing a constant head, pressure ratio, or discharge pressure line from design flow back to the surge line (see Figure 3). Like “aerodynamic stability”, “turndown” is typically expressed as a percentage. Unlike “aerodynamic stability”, “turndown” is not determined at constant speed but, as noted, at constant head, pressure ratio, discharge pressure, or the like. Since the surge/stall line typically has a positive slope, percent “turndown” will be greater than percent “aerodynamic stability.”

“Rise-to-surge” relates how much more head or pressure, typically expressed as a percentage, a compressor generates at the surge/stall line as compared to the head or pressure level at design (see Figure 2). “Rise-to-surge” can help determine a compressor’s or compressor section’s controllability, assuming

the control system is sensitive to the discharge pressure and/or pressure ratio. That is, if the control system determines where the compressor is operating based on the discharge pressure or on the overall pressure ratio, it is advantageous to have greater rise-to-surge because the greater slope in the pressure or head curve will allow a more precise assessment of the compressor flow rate. Conversely, if the compressor has a very low rise-to-surge, it is more difficult to know precisely where the unit is flow-wise.

“Overload capacity” and “choke margin” are terms used to quantify a compressor’s ability to operate at higher than design flows. As seen in Figure 2, these parameters indicate how much the flow rate may be increased before reaching the maximum useable flow rate. “Overload capacity” is a bit more difficult to define than surge margin since it is heavily dependent on the supplier’s (or user’s) interpretation of what constitutes “overload” or “choke.” Still, operation in overload can be as or more detrimental than operation in surge. Sorokes et al (2006) described the consequences of overload operation.

Most compressor manufacturers establish their “overload limit” based on a variety of considerations such as:

1. the drop in efficiency level from design; i.e., -10 points
2. the drop in head level from design; i.e., 30% of design point head level
3. the inlet relative Mach number at the impeller leading edge
4. some minimum allowable efficiency level agreed upon by the manufacturer and user

Because of the somewhat arbitrary nature of the term “overload”, it is very important that the manufacturer and end-user reach a common understanding regarding its definition.

The term “range ratio” is defined as the ratio of “overload” flow limit divided by the flow rate at surge for a given speed line (see Figure 2). This parameter has gained wide acceptance amongst purchasers of pipeline boosters. “Range ratio” is dependent on the definition of overload capacity or overload limit, so, again, the OEM and user must agree on the definition.

With range parameters defined, the discussion now turns to efficiency. The most common efficiency term used by compressor manufacturers and/or users is polytropic efficiency. The equation is given below:

$$\eta_p = \left(\frac{k-1}{k} \right) \left(\frac{\ln(\text{Pr})}{\ln(\text{Tr})} \right) \quad (3)$$

where: k = ratio of specific heats
Pr = pressure ratio
Tr = temperature ratio

Note that Equation (3) is only valid for a thermally perfect gas. Determination of polytropic efficiency for a real gas is a far more complicated effort.

Another popular expression for efficiency is the isentropic form as given below:

$$\eta_i = \frac{\text{Pr}^{\frac{k-1}{k}} - 1}{\text{Tr} - 1} \quad (4)$$

The pressure generating ability of a compressor stage or section is typically expressed as pressure ratio or head rise. Pressure ratio is intuitively obvious and the equations for head and head coefficient, μ_p , are below:

$$\text{Head}_p = \frac{\eta_p}{g_c} (U_2 C_{U2} - U_1 C_{U1}) \quad (5)$$

$$\text{Head}_p = \frac{\mu_p U_2^2}{g_c} \quad (6)$$

$$\mu_p = \frac{\text{Head}_p \bullet g_c}{U_2^2} \quad (7)$$

Where: η_p = polytropic efficiency
 g_c = gravitational constant
 C_{U1} = tangential velocity of gas entering impeller in feet per second
 U_1 = peripheral velocity of impeller leading edge = $\frac{N\pi D_1}{720}$ in feet per second
 C_{U2} = tangential velocity of gas exiting impeller in feet per second
 U_2 = peripheral velocity of impeller trailing edge = $\frac{N\pi D_2}{720}$ in feet per second
 D_1 = impeller blade inlet diameter in inches
 D_2 = impeller blade exit diameter in inches
 N = rotational speed in rotations per minute

To calculate the overall head generating capability of a compressor or compressor section, one must sum up the head generated by the each individual stage within the section or machine.

It is important to point out that all of the parameters described above are used to describe individual stage characteristics as well as overall compressor or compressor section performance.

OPERATING REQUIREMENTS

With the necessary nomenclature defined, the paper will now focus on the choices that must be made with regard to the operating requirements for a compressor with regard to the trade-off of peak efficiency and overall operating range..

Compressor applications tend to fall between two operational extremes. At one extreme are compressors that operate over a very narrow flow range; i.e. within $\pm 5\%$ of the design flow rate; and at nearly constant speed (excluding start-up and shutdown). Two examples are gas generator sections of gas turbines and compressors that supply air for manufacturing facilities. To facilitate the discussion, these compressors will be referred to as Type “N” for narrow range.

Since the Type “N” compressor operates over a very narrow flow range, it is possible to optimize its performance for that very specific flow rate. Very high peak efficiencies are possible but as Tye “N” compressors operate further from

design flow, the efficiency drops off very rapidly. The curve labeled “N” in Figure 4 is somewhat typical for such a compressor.

At the opposite extreme is compressors that must operate over a very wide flow range; i.e., $\pm 30\%$ of design flow. The wide flow range requirement may be due to a variety of circumstances; such as:

1. Non-uniform inlet or exit conditions; i.e., varying inlet or discharge pressure or temperature,
2. Changes in gas compositions,
3. Mandated changes in flow rate during certain time periods (i.e., summer and winter conditions for pipeline boosters, peak demand for LNG or other hydrocarbon processing, etc.)

These compressors are designated as Type “W” for wide range. Examples of such applications are pipeline boosters, compressors in hydrocarbon processing plants, and gas re-injection compressors.

Clearly, performance curve “N” in Figure 4 is not going to be acceptable for applications requiring wide range. Therefore, different stages or stage components must be developed for Type “W” compressor applications. These stages must maintain an acceptable level of performance as flow deviates from design. This broader or “flatter” efficiency requirement limits the attainable efficiency at the design condition because components can no longer be optimized for one condition but must operate effectively at many flow rates. There are also numerous types of impeller (i.e., high Mach number designs) or diffuser designs (i.e., channel or wedge style diffusers) that are not capable of providing optimal performance over a wide flow range. In short, a requirement for very wide flow range results in design choices that will provide a reduction in peak attainable efficiency.

Most compressor applications fall somewhere between Types “N” and “W”. The end-user and OEM must understand what the operating requirements will be for any new compressor or compressor components. They also must recognize the compromise in peak attainable efficiency level that comes with an increased range requirement or the reduction in flow range that will result when pressing for higher efficiency levels. A proper and realistic balance of range and efficiency must be agreed upon before any new compressor or compressor components can be developed or purchased.

CRITICAL COMPONENTS

Once the decision is made regarding the level of range and efficiency required, the designer can tailor the stage components to meet the requirements.

The four most important components in a multistage centrifugal are the inlet guide, impellers, diffusers, and return channels. These will be discussed in some detail. Other components; such as volutes, collectors, main inlets and sidestreams; can influence range and efficiency but only brief comments will be offered on these.

Impellers

While all components are important in achieving good overall performance, *the* most critical is the impeller. If the impeller does not provide high efficiency and good overall flow

range, it is impossible to achieve such in the overall stage. Impellers provide 100% of the kinetic energy added to the gas and can be responsible for as much as 60% to 70% of the static pressure rise in the stage. They are also the most efficient component in the stage. A well designed, mid to high flow coefficient impeller (i.e., $\phi > 0.030$) typically achieves a polytropic efficiencies in excess of 96%, meaning that only 4% of the losses in the stage are attributable to the impeller.

The losses in the stationary hardware reduce the overall stage efficiency from the “baseline” established by the impeller. Therefore, if the impeller in a stage is a bad design with a low efficiency level and poor operating range, the overall stage performance can only be worse.

There are many styles of centrifugal compressor impellers but all tend to fall into two broad categories: (1) shrouded versus unshrouded impellers; and (2) two-dimensional versus three-dimensional blades. The type chosen depends on a number of considerations including (but not limited to) required operating speed, pressure ratio desired, desired efficiency level, manufacturing capabilities, and cost. For example, the absence of a cover allows unshrouded impellers to operate at much higher rotational speeds or tip speeds, U_2 . Therefore, unshrouded or so-called “open” impellers are capable of generating very high-pressure ratios or head levels (see Equation 6). Conversely, unshrouded impellers would not be considered for low flow coefficient, low pressure ratio applications because of the high losses that would be associated with the so-called tip leakage flow from one impeller passage to the adjacent passage. Further, it would be impractical to apply unshroud impellers in multi-stage beam-style compressor applications because the stage efficiency is a strong function of the gap between the impeller and the adjacent stationary wall. In a multi-stage environment, the clearance would have to be large to account for thermal growth and/or rotor float and the clearance would degrade the attainable efficiency level.

The selection of blade style is dependent on many factors but the predominant factor from an aerodynamic perspective is the flow coefficient (or specific speed). Low flow coefficient impellers are characterized by long, narrow passages while high flow coefficient impellers are much wider with shorter channels. A classic diagram showing the relationship between flow coefficient or specific speed and the impeller geometry is shown in Figure 5. Such diagrams can be found in any number of turbomachinery textbooks, such as Shepherd (1956).

It is also more common for low flow coefficient impellers to have simpler blades such as those defined by circular arc sections, sections of ellipses, or even straight lines. Higher flow coefficient impellers typically have highly three dimensional blade shapes which cannot be defined by any common geometric shape; such as cones, cylinders, inclined cylinders, torus sections, etc. Such blades are specified using lines in space or meshes of points.

The style of blade itself can impact on the range versus efficiency compromise if the blade style is applied improperly. For example, one would not want to apply a circular arc blade in a very high flow impeller nor would one apply a highly three-dimensional blade in a low flow coefficient design. The reasons will become obvious in the discussions to follow.

The details of the blade geometry or shape are crucial to achieving good efficiency and flow range. This paper will not delve into the vast details associated with varying impeller blades but instead will touch on select critical factors that influence range and efficiency.

One such factor is the blade leading edge angles or, more specifically, the blade leading edge incidence. Incidence is defined as the difference between the relative flow angle of the gas as it approaches the rotating impeller blade and the impeller blade angle. The concept of incidence and the variation of incidence with flow rate are shown in Figure 6 for the case of a simple circular arc blade. As can be seen, the “incidence swing” from minimum to maximum flow can be substantial (at least for the illustrated example).

Using a crude 1-D approximation, the approach angle of the gas can be estimated as shown in Figure 7. The two legs of the triangle represent the tangential (Ct) and through-flow (or meridional, Cm) gas velocity. The hypotenuse represents the relative approach velocity of the gas, W1. The angle between the relative velocity and meridional velocity is the gas flow angle. The incidence angle is the difference between this flow angle and the blade angle.

The above example reflects the case of a narrow, low flow coefficient impeller with a circular arc blade. In such a design, there is little flow angle variation across the passage. However, for high flow coefficient designs with their inherently wider flow passages, the flow angle varies significantly from hub to shroud.

The flow angle variation results from two primary factors: 1) the effect of streamline curvature on the meridional velocity; and 2) the effect of radius on the impeller leading edge peripheral velocity. These effects are illustrated in Figure 8. As a crude approximation, the curvature effects can be estimated by the ratio of radii of curvature that pass through the leading edge at the shroud, mean, and hub (See Sorokes et al, 2009). The shroud meridional velocity (CmS) will be higher than the mean meridional velocity (CmM) by the ratio of the mean radius of curvature divided by the shroud radius of curvature. Similarly, the hub meridional velocity (CmH) is lower than the mean by the ratio of the mean radius of curvature divided by the hub radius of curvature.

The peripheral velocities are determined using the relationship below:

$$U_x = N \pi D_x / 720 \quad (8)$$

Where: U_x = peripheral velocity at a location “x” on the leading edge in feet per second
 N = speed in RPM
 D_x = diameter at location “x” on the leading edge in inches

By determining the resultant of the meridional and peripheral velocities, the angles at the shroud (β_{1S}), mean (β_{1M}), and hub (β_{1H}) can be calculated. These values are used to establish the necessary blade angles for the impeller. Therefore, in order to achieve optimal incidence, one must match the non-uniform flow angles across the leading edge, explaining the need for a three-dimensional blade shape.

Returning briefly to the low flow coefficient impeller, unlike the high flow coefficient design, the meridional and tangential velocities in the low flow design are not significantly influenced by the local curvature and variation in blade leading edge diameter. In many cases, the blade leading edge diameter is constant; i.e., parallel to the shaft. Further, the low flow design, by its nature, is quite narrow as compared to the high flow design. Therefore, there is no need for a three-dimensional blade to match the incoming flow angles and a simple blade with constant leading edge angle is sufficient. In fact, one might ponder how three-dimensional a blade can be when the flow passage is only 0.25” (6.4mm) wide.

The definition of optimal incidence depends heavily on the objective the designer is attempting to achieve. Peak achievable efficiency will occur when incidence is minimized across the entire leading edge. Therefore, incidence is typically minimized at the impeller’s design flow rate. As one moves away from optimal incidence, additional losses will occur in the impeller and the impeller efficiency will drop. In short, any increase or decrease in flow rate will result in non-optimal incidence, higher losses, and lower impeller performance. Consequently, if peak efficiency is paramount, one would minimize design point incidence but one would also have to recognize that off-design performance (high efficiency over a broader range) would suffer.

If greater flow range (or a broader efficiency) is desired, a designer can distribute the blade angles so that off-design operation does not result in increased leading edge incidence losses across the entire blade leading edge. This is illustrated in Table 1.

As can be seen, by biasing the blade angles so as to *not* achieve minimal incidence across the leading edge, the incidence levels are actually lower on some portion of the blade leading edge for higher flow rates (i.e., Normal, 125% design versus Biased 125% Design). That is, there is an average of -6° incidence on the unbiased distribution versus an average of -4° for the biased case. Therefore, the impeller will achieve higher off-design performance. However, this will be at the expense of efficiency at the design flow rate because the incidence levels are greater at design for the biased design.

There are numerous other impeller design considerations that influence range and efficiency. These include the relative velocity ratio, curvature along the hub and shroud, passage area distribution, the number of blades, and the intricacies of the blade shape; i.e., rate of change of blade angle. Textbooks [i.e. Shepherd (1956), Cumpsty (1989), Japikse (1996) and Aungier (2000)] have been written on this subject and there is a plethora of open literature on the topic. Therefore, it would not be prudent to attempt to address them all herein. However, one further consideration merits discussion.

The choice of impeller head or head coefficient level can have a significant influence on the flow range of the impeller and consequently, the stage. It is commonly held that a high head coefficient stage provides a narrower operating range and lower rise-to-surge than a lower head coefficient design. While not necessarily a concern for integrally geared or single stage designs, this is critical as multiple high head coefficient stages are combined because the result will be a very “flat” head coefficient characteristic; i.e., limited “rise-to-surge”. The

“flat” head rise requires a more sensitive surge control system and, in general, a narrow operating envelope.

Conversely, low head coefficient impellers provide greater rise-to-surge and are, therefore, easier to control. Consequently, they typically yield wider range than do high head coefficient impellers.

To understand the parameters that influence head rise, consider the diagrams provided in Figure 9. A generic impeller exit velocity diagram is given in Figure 9A with the critical velocity components and angles labeled. For the aerodynamic “purist,” these diagrams ignore the influence of slip, exit deviation, jet/wake effects, or the like. For the non-aerodynamicist, such parameters are models and/or correction (“fudge”) factors that are introduced in 1-D or 2-D analysis codes to account for boundary layer and secondary flow effects. Failing to treat such factors does not detract from the basic thrust of the following discussion. Note that the following also assumes a radial inlet guide upstream of the impeller.

Important variables to note are:

- The impeller exit flow tangential velocity, CU_2 , and the impeller exit peripheral velocity, U_2 . These two parameters are used along with the impeller efficiency, η_I , and gravitational constant, g_c , to calculate the head rise in the impeller. The equation for the typical case of an impeller preceded by a non-prewhirl inlet vanes is as follows:

$$\text{Head} = \frac{\eta_I}{g_c} (CU_2 \bullet U_2) \quad (9)$$

- The impeller exit flow meridional velocity, CM_2 , is a function of the impeller exit area, A_2 , in square inches and exit flow rate, Q_2 in ACFM. This velocity can be estimate using the incompressible relationship:

$$CM = 2.4 Q_2/A_2 \quad (10)$$

- The flow angles β_2 and α_2 represent the relative and absolute exit flow angles, respectively. Since slip or deviation are neglected, β_2 also is the impeller exit blade angle. Note that in this paper, flow angles and blade angles are specified relative to a radial (or axial) line.

The exit velocity diagrams in Figures 9B and 9C represent impellers with 40° of backsweep (high head) and 60° of backsweep (low head), respectively. The black lines on each plot provide the velocities for the design flow condition. The red lines reflect operation at 110% of design flow while the blue lines reflect operation at 90% of design.

First, note the relative lengths of the CU_2 vectors on the high and low head velocity triangles. The low head impeller generates less CU_2 and, therefore, less head. Now note the change in the CU_2 velocities between the high and low head velocity triangles for $\pm 10\%$ flow from design. Clearly, there is more change in CU_2 for the low head. Therefore, there will be a greater head rise on the low head (or high backsweep) impeller. The result will be more useable flow range for the higher backsweep impeller.

Also note the α_2 angles on the two diagrams. The low head stage has a more radial impeller exit flow angle, which impacts

the choices for the downstream diffuser. Typically, vaned diffusers do not perform well downstream of impellers with highly radial exit flow angles. There are two primary reasons for this. First, as seen in Figure 9, the more radial exit flow angle in the 60° design also exhibited more variation in the flow angle from high to low flow. This makes it difficult to design an effective vaned diffuser because of the large variation in incidence. Second, the highly radial flow angle implies there is less tangential velocity to redirect or “turn” via a vaned diffuser. Therefore, vaned diffusers are not generally used downstream of low head coefficient impellers. Vaneless diffusers are more common in such stages. In summary, the choice of impeller coefficient level limits the options for the downstream components and impacts the overall stage peak efficiency and flow range.

The discussion will now turn to the stationary components that are critical in the compromise between range and efficiency: diffusers, inlet guides and return channels. The order of importance is both a matter of opinion and dependent on whether one is concerned with wide flow range or peak efficiency. As will be seen, the inlet can be far more influential on the flow range and can certainly impact the efficiency but the diffuser likewise can play a key role in establishing both range and efficiency. Based on recent experience, the return channel must be placed behind both the IGV and the diffuser in its importance to the overall stage performance characteristics.

Inlet Guides

The inlet guide, if present, can be the second most important component in a centrifugal compressor. In beam-style machines, inlet guides with their so-called guide vanes accept the flow from the compressor main (or sidestream) inlet or a return channel and introduce the flow into the eye of a downstream impeller. Inlet guides can take on a variety of different configurations and in some situations are simply extensions of the return channel or inlet section. The detailed design and description of the various arrangements is not germane to this discussion. What is important is the influence that inlet guide vanes (or IGVs) can have on the downstream impeller.

The most common form of inlet guide vanes is the so-called “radial” vanes. The flow exiting “radial” guide vanes is typically in a purely axial direction. The term “radial” reflects the fact that the vane centerline falls along a radial line passing through the center of the compressor shaft. The exit flow of such vanes is intended to have no tangential velocity but be purely in the meridional or through-flow direction.

If one puts some curvature in the vanes or orients the vanes other than in a purely radial direction, the exit flow will have both a meridional and tangential velocity as sketched in Figure 10. The tangential component of the velocity is often called “pre-whirl” or “pre-swirl” and such inlet guides and guide vanes are typically called “pre-whirl inlet guides” or “pre-whirl guide vanes.” Further, depending on the direction of rotation of the compressor shaft (purposefully *not* indicated in Figure 10), the “pre-whirl” can be either “against” the direction of rotation or “with” the direction of rotation; hence the names “against IGV” and “with IGV.”

The “pre-whirl” causes a change in the inlet velocity field or inlet velocity triangle into on the downstream impeller as indicated in Figure 11. By introducing “with rotation”, the flow angle of the gas entering the impeller for a given flow rate decreases (see the blue dashed lines). This results in negative incidence on the impeller leading edge. To bring the incidence back to the optimal level; i.e., near zero; the flow rate must be reduced (recall that the meridional velocity C_1 is a function of the inlet flow). Conversely, if the inlet guide creates “against rotation,” the flow angle increases (i.e., the green lines). This causes positive incidence at the impeller leading edge, so the flow rate must be increased to achieve optimal incidence.

Putting it all together, by changing the inlet guide in front of a given impeller, it is possible to adjust the flow map as shown in Figure 12. Again, adding “with pre-whirl” shifts the map to lower flow rates while adding “against pre-whirl” move the map to higher flow rates. Therefore, it is possible to adjust the location of the peak efficiency with “pre-whirl” inlet guide vanes.

Several factors limit the amount of shift that can be effectively achieved. First, the additional turning of the flow can result in additional losses in the guide vane, reducing the overall efficiency of the stage. Second, if the turning in the inlet guide vanes becomes too severe, the inlet guide will behave more like a throttle valve, resulting in a pressure loss and further efficiency degradation. Third, the “pre-whirl” causes a change in the inlet relative gas velocity. While potentially advantageous for “with” rotation because “with” rotation decreases W_1 , this can be a problem for “against” rotation because W_1 and $Mach\ W_1$ will increase. Fourth, to achieve reasonable turning, the vane count in the inlet guide must increase, causing more wetted surface and higher friction losses.

In summary, the inlet guide can be a major player in achieving the proper balance between range and efficiency but there are a large number of issues that must be considered.

Diffusers

The centrifugal compressor diffuser is arguably the second most critical component in achieving high stage performance and good flow range. The diffuser converts a portion of the remaining kinetic energy in the gas stream (velocity pressure) into static pressure, further reducing the volumetric flow.

The most common term used to assess diffuser performance is static pressure recovery, C_p . C_p is the percentage of velocity pressure converted to static pressure and is defined as follow:

$$C_p = \frac{P_{s_{exit}} - P_{s_{inlet}}}{P_{t_{inlet}} - P_{s_{inlet}}} \quad (11)$$

Where: $P_{s_{exit}}$ = static pressure at the exit of a component
 $P_{s_{inlet}}$ = static pressure at the inlet of a component
 $P_{t_{inlet}}$ = total pressure at the inlet of a component

Centrifugal compressor diffusers fall in two broad categories: vaneless and vaned. As indicated by their name, vaneless diffusers contain no vanes in the flowpath between the impeller

exit and the downstream return (or 180°) bend. Conversely, vaned diffusers contain one or more rows of vanes.

In general, vaneless diffusers offer the widest flow range because there are no vanes to interfere with the gas as it moves through the diffuser. That is, additional vanes introduced into the compressor gas path provide locations for additional incidence and friction losses. Obviously, vaneless diffusers cannot suffer from incidence losses. However, vaneless diffusers do not provide as much static pressure recovery as their vaned counterparts. Therefore, the peak attainable efficiency for stages with vaneless diffusers is not as high.

A well-designed vaneless diffuser can achieve C_p 's on the order of 0.5, although most vaneless diffusers C_p 's are in the range of 0.3 to 0.4.

Though the flow range of vaneless diffusers is quite high, designers must be wary of diffuser rotating stall. Rotating stall occurs due to flow separations and/or insufficient radial momentum in the diffuser passage. The result is a non-uniform circumferential static pressure distribution that leads to unbalanced forces on the rotor. These unbalanced forces cause undesirably high levels of subsynchronous radial vibration. Such vibrations limit the useable operating range of the stage and/or compressor, so designers must take steps to insure rotating stall will not occur. There are a tremendous number of references on this subject and the reader is encouraged to review the following references for more information: Frigne et al (1984), Kobayashi et al (1990), and Marshall and Sorokes (2000).

The most common causes for diffuser rotating stall are diffuser widths being set too wide and excessively long (or high exit to inlet radius ratio) diffusers. Diffuser rotating stall can also be instigated if the upstream impeller delivers a highly skewed hub to shroud velocity distribution to the diffuser.

With regard to vaned diffusers, there are many styles including wedge, airfoil, piped, low solidity vaned, rib, and cascade. In some cases, the vanes extend from near the impeller exit to the entrance of the return bend. In others, the vanes only occupy a short portion of the radial space (see Figure 13) and in the case of the rib diffuser, the vanes do not cross the entire diffuser passage. The vanes also take on a variety of shapes as can be seen in Figure 14.

One will note that some styles of vaned diffusers form a very defined passage (i.e., there is a high degree of solidity or overlap) while others do not form a true passage. The former style is commonly called a channel diffuser. The latter type is characterized as being a low solidity vaned diffuser (or LSD or LSA). Numerous publication have touted the advantages of the LSD style including Senoo et al(1983), Osborne and Sorokes (1988), Sorokes et al (1992, 2000), and Amineni and Engeda et al (1995, 1996). Sorokes and Kopko (2001) provided an overview of rib diffusers and their advantages and disadvantages relative to LSDs. The most important consideration for this discussion is that LSDs and rib diffusers provide nearly the same operating range as vaneless diffusers yet provide some of the efficiency-enhancing benefits of a channel diffuser.

Regardless of the style, vaned diffusers do not provide as much operating range as vaneless diffusers. The primary delimiter is flow incidence on the diffuser vanes. Like the

impeller, incidence is defined as the difference between the flow angle of the gas and the inlet angle of the diffuser vane. As noted previously, in this paper, incidence is further defined as flow angle minus vane angle.

The variation in diffuser incidence angle for a centrifugal stage is illustrated in Figure 15. When operating near design, the incidence on the vanes is near zero. As flow is increased, the gas angle becomes more radial and incidence becomes more negative. Eventually, the negative incidence becomes high enough that the diffuser vanes act more as an obstruction rather than a guide. The flow separates from the vanes, large wakes form, diffuser losses increase dramatically and the overall performance of the stage plummet.

Conversely, as flow is decreased from design, the gas angle becomes more tangential and positive incidence occurs. When the positive incidence reaches a critical level, flow separation will occur and the losses will escalate. The increased losses as well as possible aero-mechanical forces will limit the useable operating range toward surge. In short, both ends of the performance map will be limited by diffuser incidence.

Well-designed, high solidity vaned diffusers provide the highest static pressure recovery but the narrowest operating range. Static pressure recoveries in the range of 0.7 to 0.8 are possible. Low solidity designs provide wider range but at the expense of peak pressure recovery. A typical LSD can yield static pressure recoveries in the 0.5 to 0.7 range.

One other factor arises in high solidity vaned diffuser, the diffuser throat. Because of the high solidity, a minimum diffuser passage area is formed near the leading edge. If the designer is not careful, it is possible to undersize this throat area and cause it to choke the flow. This will further inhibit the overload capacity and useable range of a stage.

In summary, the choice of diffuser must be driven by the overall range and efficiency requirements for a given operation. Each type of diffuser has its strengths and weaknesses and it is incumbent on the designer to insure that the proper style is used for any given application.

Return Channels

The last component that will be discussed in detail is the return channel or deswirl cascade. The primary purpose of this component is to remove any remaining tangential velocity from the flow stream and effectively introduce the gas into the next impeller. However, additional static pressure recovery may be achieved in the return channel. However, care must be taken since the flow would be simultaneously diffusing and turning, not a good situation in fluid flow and a potential source for flow separation.

As can be seen in Figure 16, like the high solidity vaned diffuser, a return channel has a setting (or leading edge) angle and a geometric throat. Also like the vane diffuser, the leading edge angle and throat area must be sized to properly accept the flow exiting the upstream diffuser. Again, at off-design operation, incidence effects cause an increase in losses and reduce both efficiency and overall operating range.

Other factors influencing return channel losses are the area schedule through the return channel passage and the rate of turning of the flow. If the area increases too rapidly, flow separation can occur. The consequence will be a distorted

flowfield entering the downstream impeller. Premature stall or excess losses can result, again limiting flow range and peak performance.

Recall that the primary purpose of the return channel is to remove the tangential velocity from the gas stream and redirect the flow radially for entry into the downstream impeller. Therefore, the gas must be turned on the order of 45 to 70 degrees by the return channel vanes. If this turning is too abrupt, flow separation will again occur. Conversely, if the flow is not turned rapidly enough, it is possible that some amount of tangential velocity will remain in the gas stream. This remaining tangential velocity or swirl will effect the performance of the downstream impeller, reducing its capacity and head-generating capability. The result will again be reduced operating range.

Other Components

Other components, such as main inlets, discharge volutes or collectors, and sidestreams are required to complete the compressor flow path. Like the impeller, diffuser, return channel and inlet guide, these components can impact both the range and the achievable efficiency of a compressor and there are many design considerations that must be properly addressed to insure the satisfactory performance of these components.

Main inlets

The primary function of a main inlet is to accept flow from the inlet piping and to distribute said flow as uniformly as possible around the circumference of the machine. More details on centrifugal compressor inlet design can be found in the open literature, such as Flathers et al (1994), Koch et al (1995), Michelassi et al (1997) and Kim et al (2004).

Any non-uniformity of the pressure or velocity field entering the first stage impeller can have detrimental effects on both the performance map for the stage. For example, if the flow does not enter the impeller uniformly, surge / stall margin and overload capacity can be compromised. Therefore, OEMs will add various features; such as splitter plates, "seagulls", scoop vanes or the like; to help guide the flow from the inlet pipe to the inlet of the first stage impeller (See Figure 17). Of course, adding further vane elements also introduces sources for additional losses due to vane incidence, increase in wetted surface (friction losses), and other secondary flow-related effects. In fact, if the designer is not careful, it is possible to tune an inlet section for a specific flow rate and severely compromise the performance of said inlet for off-design operation. There, it is imperative that the designer consider the full range of operating conditions required when establishing the inlet configuration and the number of vaned elements to be included.

Inlets can range from simple straight pipes or ASME bell-mouths for axial inlet compressors to highly sophisticated, scheduled-area inlets that are custom-tuned for a specific flow condition. Much like the channel diffuser as compared with a vaneless diffuser, the custom-tuned inlet will provide peak performance over a very narrow flow range but restrict the overall flow range. Conversely, a simpler inlet will have greater design point losses but will offer a broader operating envelope.

Discharge Volutes / Collectors

Discharge volutes and collectors and the antithesis of the main inlet. While the inlet distributes flow circumferentially, the volute or collector gathers the flow from the last (or single) stage and directs the flow down the discharge pipe (See Figure 18). There are several excellent papers on volutes and collectors available in the open literature including Ayder (1993, 1994), Xu and Muller (2005), etc. As with all other primary flow path components, proper sizing of the volute or collector is of utmost importance. If the volute or collector is undersized, the overload capacity of the compressor can be compromised. That is, if the volute or collector area is insufficient, the velocities will increase and cause higher losses, resulting in a drop in efficiency and an associated drop in usable operating range. Conversely, if one over-sizes a volute or collector, the flow velocity drops and separation can occur from the walls of the volute. Further, vortices and other flow anomalies will occur that will result in a reduction in the compressor performance. Should these flow anomalies become large enough so as to cause non-uniformities in the pressure / velocity field in the volute / collector, it is possible that the volute / collector will create non-uniform pressure forces on the upstream rotor and could promote premature stall of the upstream stage.

Additional losses can also result due to the shape of the volute / collector. It is commonly known that a volute with a circular shape provides superior performance because such a shape is not prone to the corner vortices that occur in volutes with more rectangular or square cross-sections. However, the so-called “circular volutes” are more difficult to manufacture and OEMs must often resort to castings whereas more rectangular volutes can be machined. Castings are prone to surface anomalies or rough surface finishes that can also cause excess losses. In addition, castings require expensive patterns and, if custom-sizing of the volute is required, a large number of patterns will also be required. The machined volute will typically have a very precise flow path and smooth surfaces but, again, the non-circular cross-section is prone to additional losses due to corner vortices or the like. One must also consider the large amount of machining time necessary to build the volute. Therefore, the OEM must consider all of these factors when choosing between the cast and machined components and when deciding on the sizing of and number of unique volute / collector sizes for a new product.

Like the inlet, custom-sizing of volutes and collectors can provide higher performance at specific flow rates but will compromise the off-design performance. Therefore, the designer must be aware of the potential compromises of range and efficiency rooted in the volute / collector design.

Sidestreams

Sidestreams or “side entries / exits” are components used to add or extract flow from a multi-stage compressor other than at the main inlet or main discharge. Sidestreams take on a variety of configurations and OEMs use different design philosophies (see Figure 19). Numerous publications have addressed the design features and philosophies of sidestreams; i.e., Sorokes et al (2000, 2006), Hardin (2002), and Koch et al (2011).

Therefore, these will not be described herein. Suffice it to say that a sidestream is typically some combination of a diffuser, return channel, inlet guide, inlet, and/or volute/collector. These various components have already been addressed previously and the basic considerations for the design of such in a sidestream situation do not change.

Of course, there are aspects of the sidestream that can have major consequences on the range and efficiency of the compressor. For the incoming sidestream, that factor is the matching or mixing of the sidestream flows at the “mixing section.” If the sidestream entrance passage is not sized properly, the downstream impeller will ingest a skewed hub-to-shroud velocity and pressure field, potentially leading to premature stall or premature choking of the impeller due to incidence and/or secondary flow effects.

For the outgoing sidestream, it is necessary to understand/account for the behavior of the flow remaining in the compressor after the sidestream flow has been extracted. If the flow passages are not sized correctly, the result will again be premature stall or possibly higher losses due to higher than desirable velocities.

As with inlets or volutes/collectors, there are features that can be introduced to a sidestream to minimize the losses for a particular flow condition but doing could compromise flow range. Therefore, one must consider the potential trade-offs between range and efficiency in sidestream design just like with other flow path components.

AERODYNAMIC MATCHING

There is more to achieving good overall performance than designing individual components that provide adequate range and low loss / peak efficiency. The designer must also ensure that the components are properly matched with one another. This must be done within a given stage as well as in mating stages in a multi-stage compressor.

Stage Components

Experience has shown and common sense dictates that unless the individual components within a stage are properly matched aerodynamically, optimal stage performance cannot be achieved. For example, if an impeller is sized to provide peak performance at flow coefficient “ ϕ ” and the downstream vaned diffuser’s and return channel’s optimal performance occurs at flow coefficient 0.9 times “ ϕ ”, the combination of the three components will not provide the peak attainable efficiency. Such a mismatch is illustrated in the plot on the left in Figure 20. The impeller is at minimal loss but the diffuser and return channel are not. In the plot in the center of Figure 20, the impeller is oversized while the diffuser and return channel are slightly undersized. Therefore, again, the losses for the overall stage are not minimized. Were the component “loss buckets” properly aligned, as shown in the plot on the right in Figure 20, a higher peak efficiency would be achieved.

Good aerodynamic matching becomes more important for components that provide a very narrow “loss bucket”. As noted previously, vaned diffusers have a much narrower minimum loss flow range than do vaneless diffusers. Therefore, it may be possible to obtain acceptable performance with an under- or oversized vaneless diffuser. Reviewing

Figure 21, given the flatter “loss bucket” for the vaneless diffuser, it is easy to see how a slight variation from the minimum loss flow will still provide good performance. In other words, some amount of aerodynamic mismatching will still yield acceptable performance. Conversely, a similar level of mismatching with a vaned diffuser will cause a more significant (and likely unacceptable) reduction in performance.

Of course, matching is of considerable importance when considering the trade-off between overall flow range and peak efficiency. In fact, improper matching will result in a loss of both flow range and peak efficiency. Consider again the example in Figure 20. Since the diffuser and return channels are undersized, the overload capacity of the stage will be reduced. Conversely, when operating at reduced flow rates where the diffuser and return channel losses are lower, the impeller losses will be higher or the impeller may stall, resulting in a loss in stability or turndown.

Stage To Stage

Like component matching when assembling individual stages, matching of stages in a multistage compressor is crucial to achieving optimal flange-to-flange performance. As the flow passes through a stage, the volumetric flow rate is reduced because of the increase in gas density. Therefore, subsequent stages must be sized correctly to accept the reduced volume flow. If the downstream stage is not properly sized, the stage will not operate at its best efficiency point (BEP) and overall performance will be compromised.

The series of performance curves in Figure 22 represent a three-stage compressor. In each case, the first three curves represent the stage characteristics while the fourth (labeled ϕ OVERALL) provides the overall flange-to-flange performance. The dashed vertical lines labeled “D” indicate where each stage must operate when the compressor is near design flow. The solid vertical lines labeled “S” indicate where each stage operates as the inlet flow to stage one is reduced. In Figure 22(a), the stages are properly matched; i.e., all are operating at (or near) their best efficiency point for the design condition. As the compressor or first stage is moved to a lower flow rate, the cascading effect of volume reduction can be seen on the latter stages. Note that the third stage shows the largest volumetric flow variation and that the reduction. Also note that the curve shape of the overall compressor is different from that of any of the individual stages.

Consider now the performance curves in Figure 22(b). Stage 3 has been purposefully oversized to show the impact of improper matching on the overall performance curve. Compare the overall curve in 19 (a) and (b). Though the individual stage characteristics are nearly identical (i.e., the general shape of the curves, rise to surge, etc.), the poorer overall result in Figure 22(b) due to the inadequate matching is clear. Note further that both operating range and peak efficiency are impacted by the poor matching. In fact, since oversized, stage 3 is at surge for flow condition “S”.

OPERATING CONDITIONS

Compressor manufacturers and end users must be aware of how changes in operating conditions can impact the matching of components within a stage or between stages in a

compressor. These changes include alternate operating speeds, varying the mole weight of the gas, and/or different inlet conditions (i.e., pressure, temperature).

In very general terms, any change in conditions that increase the volume reduction in the first stage of a multi-stage compressor (i.e., increased speed, heavier mole weight gas, higher “k” value) will cause all subsequent stages in the machine to operate further to the left on their operating maps. The result will be reduced overall surge margin since the last stage in the compressor will be operating closer to its surge line than it was under the original operating conditions.

Conversely, anything that decreases the volume reduction of the first stage will increase the flow rates into subsequent stages and reduce the overload capacity of the compressor. Again, this results since the last stage (or latter stages) will operate at higher flow rates at the alternate conditions than in the original.

To help visualize the impact of changes in mole weight on stage performance, a typical map is given in Figure 23. The curve provides the efficiency and head coefficient for a stage having fixed geometry operating at a fixed speed. The three sets of curves show how the performance changes for different gas mole weights. The curves labeled “heavy” would be for heavy hydrocarbons such as propane, propylene, carbon dioxide or the like. The “middle” curves would be for gases such as natural gas, air, nitrogen and similar. Finally, the curve labeled “low” would be for very light mole weights such as helium, hydrogen, ammonia, and the like.

Note first the change in efficiency level for the three mole weights. The heavier mole weight gases will produce higher losses due to the high Mach numbers or viscous effects associated with such dense gases. Conversely, the lighter mole weight gases will produce lower losses and, therefore, achieve higher efficiency levels.

The impact of changing mole weights on the flow range ratio can also be seen in Figure 23. Operations with heavy mole weight gases will have much narrower flow range than those with lighter mole weights. The range ratios for the mixtures shown are 1.5, 1.7, and 2.0 for the heavy, middle, and low, respectively.

As seen above, the performance map for an overall compressor will be narrower than that of any of its individual stages. That is, a compressor having multiple stages, each with a performance curve similar to the “heavy” curve in Figure 23 cannot have a range ratio as high as 1.5. The range ratio for the compressor will be considerably less. The same is true for compressor with “middle” or “low” mole weight stages. Their overall range ratio will be less than the lowest range ratio of any of its individual stages. Clearly, the supplier and end-user must be aware of this fact when establishing the range requirements for a compressor.

The impact of the stage changes becomes even more apparent when considering the impact on the a multi-stage machine as can be seen in Figure 24. This represents the change that would occur in each stage of a three stage machine of fixed geometry were the speed or mole weight to be increased. As can be seen, while all stages are properly matched and operating at their peak efficiency in the first row, the clear effect of increased speed or increased molecular weight can be seen in the second and third rows of figures. If

the speed or mole weight increase is significant enough, it is possible that the flow to the last stage would exceed its capacity and the machine would choke or “stonewall.”

MOVABLE GEOMETRY – TILTING THE BALANCE

One viable approach to achieve both high efficiency and a broader operating range is movable geometry. Throughout the discussion to this point, comments have been offered regarding the increase in losses and/or decrease in efficiency for off-design operating conditions. Many of these losses have been attributed to increases in incidence levels on the stationary components (i.e., diffusers or return channel vanes). Logic dictates that one could improve the situation if one could adjust the vane inlet angles to match the flow angles for off-design operation. In doing so, one would reduce the losses at that operating condition and, therefore, increase the efficiency.

Similarly, if one were to implement movable inlet guide vanes, one could “broaden” the flow coverage map for an impeller. Consider again Figure 12. The curve in the center (solid black line) is the performance map for the impeller preceded by a radial (or zero pre-whirl) guide vanes. Were the vanes in the upstream IGV to be adjustable, it would be possible to shift the performance characteristic of the impeller to lower flow (i.e., “with” rotation – long dash red line) or higher flow (i.e., “against” rotation – short dash blue line) by rotating the vanes to a different position. It would also be possible to “custom tune” the IGV setting angle to a specific operating condition. The potential benefits are obvious.

Movable geometry is quite commonplace in integrally-g geared and axial compressors because of the easy access to flow path components. That is, the walls of the inlet guide and/or diffuser in an integrally-g geared centrifugal and the shroud wall of an axial compressor are readily accessible from outside the machine. However, movable geometry in beam-style, multi-stage centrifugal present more challenges to the designer because the vanes that one would want to move are buried within the compressor bundle and indicated by the colored blocks in Figure 25. Centrifugal compressor OEMs, including the author’s company, have applied movable geometry in the first stage of multi-stage since the 1950’s using configurations similar to that shown in Figure 26.

Sorokes et al (2009) addressed recent results of a multi-stage compressor that included movable geometry in the IGVs, diffusers, and return channels of a four-stage compressor. Their results indicated that the movable IGV was the most influential in adjusting the performance of the high inlet relative Mach number impellers (i.e., $M_{relIT} \geq 0.94$) tested (see Figure 27). This is not surprising because the IGV alters the flow rate at which optimum incidence occurs in the impeller, altering or moving the impeller performance map. Altering the vaned diffuser did impact the stall margin and rise to surge while the adjustable return channel had minimal impact other than in the high capacity portion of the performance map. Sorokes and Welch (1992) also demonstrated that a rotatable low solidity vaned diffuser could be effectively used to improve the slope of the head coefficient curve.

The greatest concern in applying movable geometry to production equipment is reliability. Given the forces acting on the vanes as well as the potential for fouling of the vanes or the

actuation system, loss of function can eliminate the advantages of movable geometry, or worse, can take a compressor out of production. Therefore, great care must be taken when deciding to design and/or implement movable geometry into a production compressor. Still, the potential advantages warrant further investigation of movable geometry systems to improve the flow range over which peak efficiency can be provided.

CONCLUDING REMARKS

The paper has addressed the compromise faced by centrifugal compressor users and designers on whether to pursue peak efficiency, wide overall operating range, or some balance of the two. Wide range and high efficiency are mutually opposing forces in the industrial compressor. Users and designers alike understand of how the various design choices impact the performance compromise.

The paper described how component designs such as impellers, inlet guide vanes, diffusers, and return channels impact the balance between efficiency and overall flow range. Similarly, the importance of proper aerodynamic matching of these components within a stage or from stage-to-stage within a compressor is emphasized. Finally, the paper offered comments on the potential advantages of movable geometry in delivering both higher efficiency and a broader operating range, provided a reliable actuation system can be implemented.

In closing, end users must have a detailed understanding of their overall process requirements and relay this information to the compressor supplier. The designer can then tailor the centrifugal compressor to the user’s application to insure that the finished product meets the user’s objectives. Their mutual goal is the best possible range and efficiency for the application.

DISCLAIMER

The information contained in this document consists of factual data, and technical interpretations and opinions which, while believed to be accurate, are offered solely for informational purposes. No representation or warranty is made concerning the accuracy of such data, interpretations and opinions.

REFERENCES / BIBLIOGRAPHY

- Amineni, N., Engeda, A., Hohlweg, W., Boal, C., “Flow Phenomena in Low Solidity Vane Diffusers of an Air Packaging Compressor,” ASME paper no. 95-WA/PID-1 (1995)
- Amineni, N., Engeda, A., Hohlweg, W., Direnzi, G., “Performance of Low Solidity and Conventional Diffuser Systems for Centrifugal Compressors,” ASME paper no. 96-GT-155 (1996)
- Aungier, R. H., *Centrifugal Compressors*, ASME Press, (2000)
- Ayder, E., “Experimental and numerical analysis of the flow in centrifugal compressor and pump volutes,” Ph.D. dissertation, Von Karman Institute for Fluid Dynamics, Rhode Saint Genese, Belgium, (April 1993)
- Ayder, E. and Van den Braembussche, R., “Numerical analysis of the three-dimensional swirling flow in centrifugal compressor volutes,” Transactions of the ASME, Journal of Turbomachinery, vol. 116, no. 3, pp. 462–468, (1994)

- Cumpsty, N. A., *Compressor Aerodynamics*, Longman Scientific & Technical, (1989)
- Flathers, M.B., Bache, G.E., Rainsberger, R., "An Experimental and Computational Investigation of Flow in a Radial Inlet of an Industrial Pipeline Centrifugal Compressor," ASME Paper No. 94-GT-134 (1994)
- Frigne, P., Van den Braembussche, R., "Distinctions Between Different Types Of Impeller And Diffuser Rotating Stall In A Centrifugal Compressor With Vaneless Diffuser," ASME Paper No. 83-GT-61; *Transactions ASME Journal of Engineering Gas Turbine and Power* 106(2): pp. 468-474 (1983)
- Hardin, James R., "A New Approach to Predicting Centrifugal Compressor Sideload Pressure", IMECE2002-39592, Proceedings of ASME International Mechanical Engineering Congress & Expo (2002)
- Japikse, D., *Centrifugal Compressor Design and Performance*, Concepts ETI, Inc., (1996)
- Kobayashi, H., Nishida, H., Takagi, T., Fukushima, Y., "A Study On The Rotating Stall Of Centrifugal Compressors," (2nd Report, Effect of Vaneless Diffuser Inlet Shape On Rotating Stall) *Transactions Of JSME* (B Edition), 56(529): 98-103 (1990)
- Kim, Y., Koch, J., "Design and Numerical Investigation of Advanced Radial Inlet for a Centrifugal Compressor Stage", IEMCE2004-60538, Proceedings of ASME International Mechanical Engineering Congress & Expo (2004)
- Koch, J.M., Chow, P.N., Hutchinson, B.R., Elias, S.R., "Experimental and Computational Study of a Radial Compressor Inlet," ASME Paper No. 95-GT-82 (1995)
- Koch, J.M., Belhassan, M., Sorokes, J.M., "Modeling and Prediction of Sidestream Inlet Pressure for Multi-Stage Centrifugal Compressors," *Turbomachinery Symposium Proceedings*, Texas A&M (2011)
- Marshall, D.F. and Sorokes, J.M., "A Review of Aerodynamically Induced Forces Acting on Centrifugal Compressors, and Resulting Vibration Characteristics of Rotors," *Turbomachinery Symposium Proceedings*, Texas A&M (2000)
- Michelassi, V., Giachi, M., "Experimental and Numerical Analysis of Compressor Inlet Volute", ASME 97-GT-481 (1997)
- Osborne, C. and Sorokes, J.M., "The Application of Low Solidity Diffusers in Centrifugal Compressors," *Flows In Non-Rotating Turbomachinery Components*, ASME FED 69 (1988)
- Senoo, Y., Hayami, H., Ueki, H., "Low-Solidity Tandem-Cascade Diffusers for Wide Flow Range Centrifugal Blowers," ASME paper no. 83-GT-3 (1983)
- Shepherd, D. G., *Principles of Turbomachinery*, MacMillan Publishing Co., (1956)
- Sorokes, J.M. and Welch, J.P., "Experimental Results on a Rotatable Low Solidity Vaned Diffuser," ASME paper no. 92-GT-19 (1992).
- Sorokes, J.M. and Koch, J.M., "The Influence of Low Solidity Vaned Diffusers on the Static Pressure Non-Uniformity Caused by a Centrifugal Compressor Discharge Volute," ASME paper no. 00-GT-454 (2000)
- Sorokes, J.M., Nye, D.A., D'Orsi, N., and Broberg, R., "Sidestream Optimization Through the Use of Computational Fluid Dynamics and Model Testing," *Turbomachinery Symposium Proceedings*, Texas A&M (2000)
- Sorokes, J.M. and Kopko, J.A., "Analytical and Test Experiences Using a Rib Diffuser in a High Flow Centrifugal Compressor Stage," ASME Paper No. 2001-GT-320 (2001)
- Sorokes, J.M., Miller, H.F., Koch, J.M., "The Consequences of Compressor Operation in Overload," *Turbomachinery Symposium Proceedings*, Texas A&M (2006)
- Sorokes, J., Kopko, J., Koch, J., "Sidestream optimization for LNG compressor applications", European Fluid Machinery Congress, (2006)
- Sorokes, J.M., Kopko, J.A., Geise, P.R., Hinklein, A.L., "The Influence of Shroud Curvature and Other Related Factors on Impeller Performance Characteristics," ASME paper no. GT2009-60109, (2009)
- Sorokes, J.M., Soulas, T.A., Koch, J.M., Gilarranz, J.L., "Full-Scale Aerodynamic and Rotordynamic Testing for Large Centrifugal Compressors," *Turbomachinery Symposium Proceedings*, Texas A&M (2009)
- Xu, C., Muller, M., "Development and Design of Centifugal Compressor Volute," *International Journal of Rotating Machinery*, 2005:3 pp 190-196 (2005)

ACKNOWLEDGEMENTS

The author acknowledges Thomas H. Euston and the late Charles E. Green for emphasizing the importance of commonsense and practical engineering methods in the design of centrifugal compressors. The author also thanks Ed Thierman, Jay Koch and Rob Kunselman for their help in preparing the figures in this paper. The author recognizes Dresser-Rand for allowing this paper to be published and Texas A&M University for providing an excellent venue at which to present this work.

Table 1. Biased blade angles to reduce off-design incidence

	Flow Rate	Incidence (in degrees)		
		Shroud	Mean	Hub
Normal	75% Design	+8	+8	+8
	Design Flow	+1	+1	+1
	125% Design	-6	-6	-6
Biased	75% Design	+7	+10	+13
	Design Flow	0	+3	+6
	125% Design	-7	-4	-1

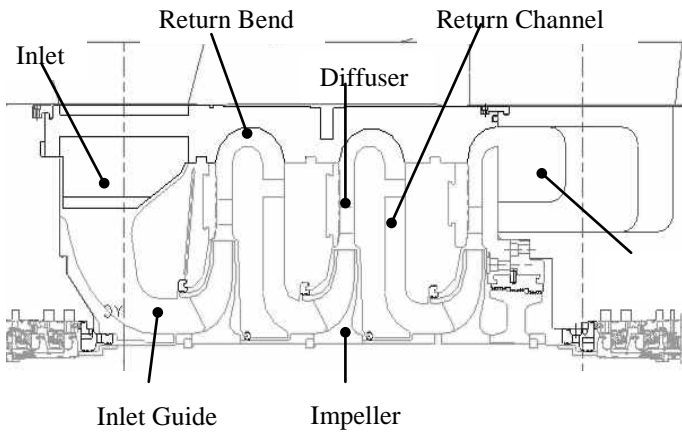

Figure 1. Compressor Cross Section with Major Components

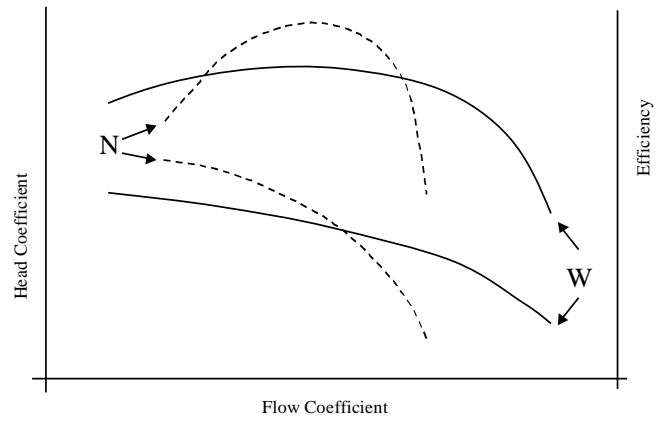

Figure 4. Typical Compressor Performance Characteristics

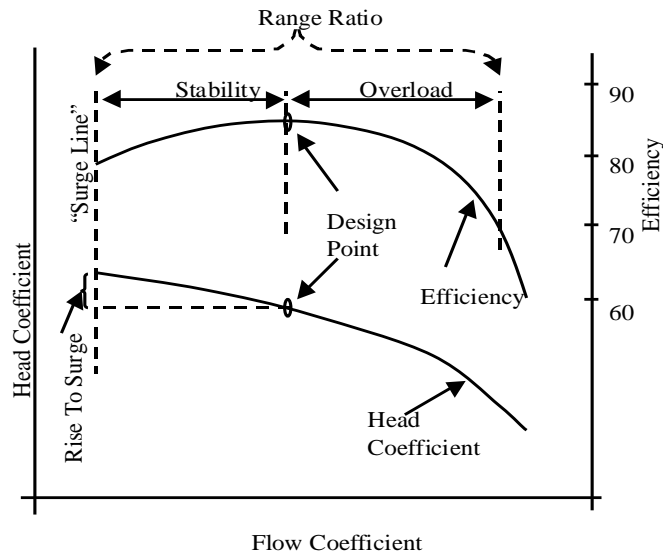

Figure 2. Typical Performance Assessment Parameters

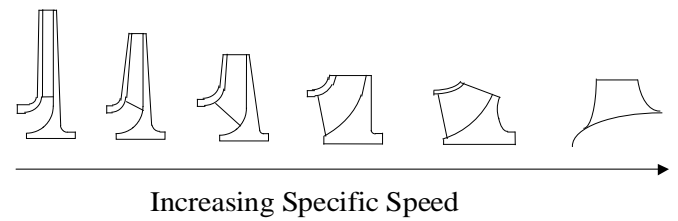

Figure 5. Impeller Style versus Specific Speed

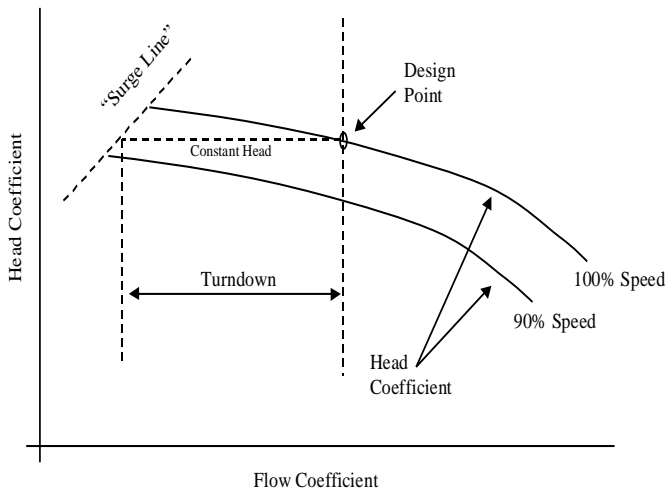

Figure 3. Definition of Turndown

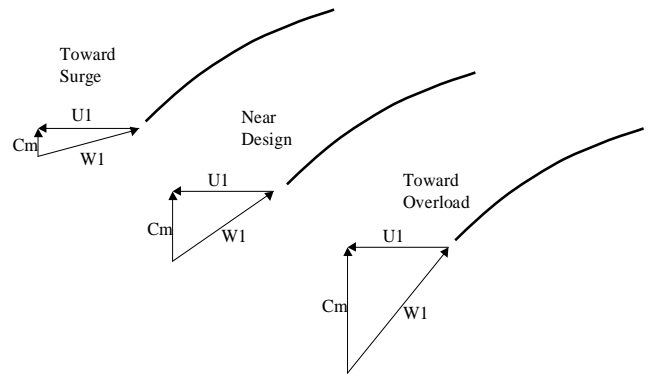

Figure 6. Variation of Impeller Incidence with Flow Rate

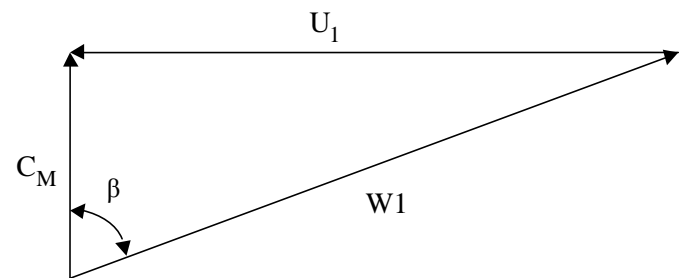

Figure 7. Impeller inlet velocity triangle

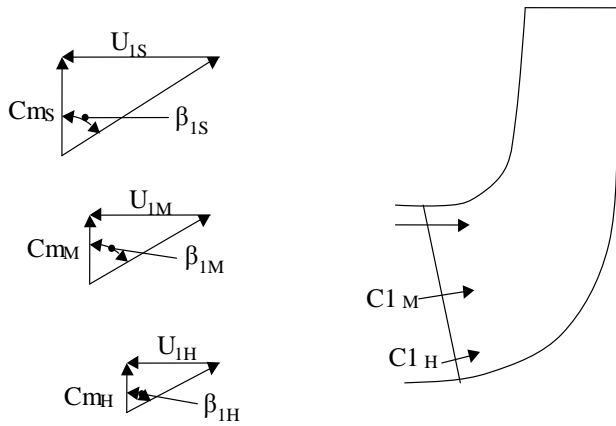

Figure 8. Impeller inlet velocity – High Flow Coefficient Impeller

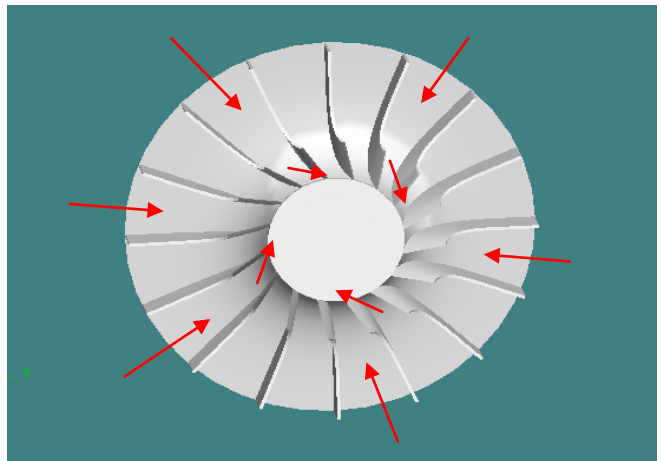
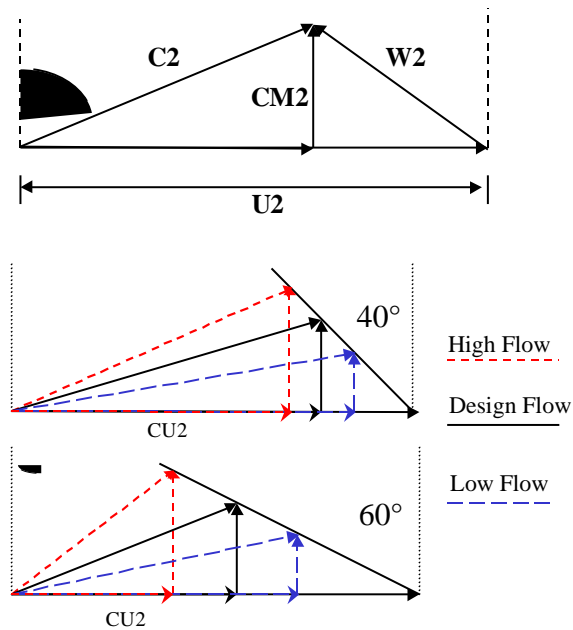

Figure 10. Preshirl Inlet Guide Vanes

Figure 9. Impeller Exit Velocity Triangles – (a) nomenclature; (b) 40° backsweep; (c) 60° backsweep

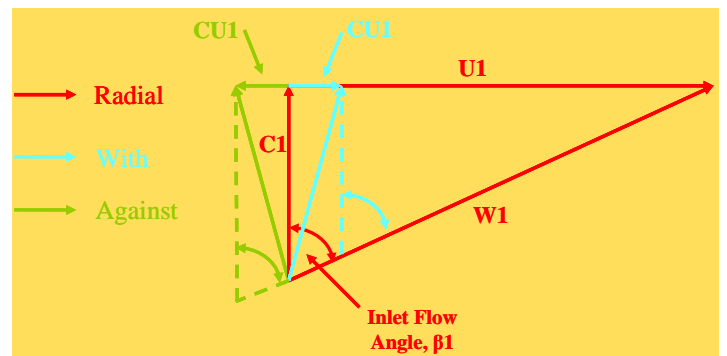

Figure 11. Impeller Inlet Velocity Triangle – Radial (red), “With” Rotation (blue), “Against” Rotation (green)

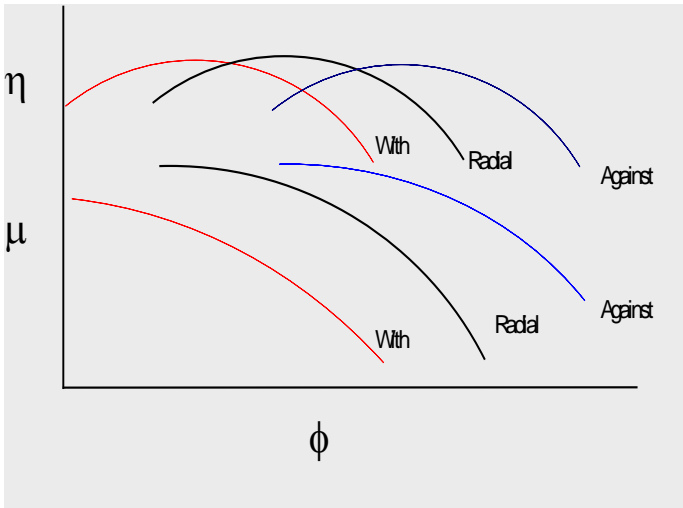

Figure 12. Effect of Prewhirl on Stage Performance

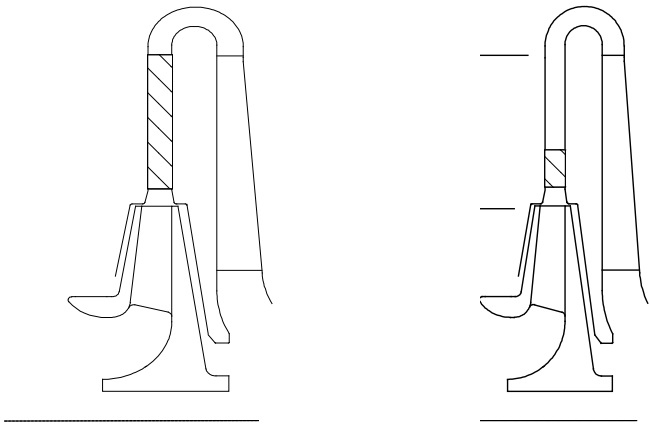

Figure 13. Diffuser Styles – Cross-Sectional View

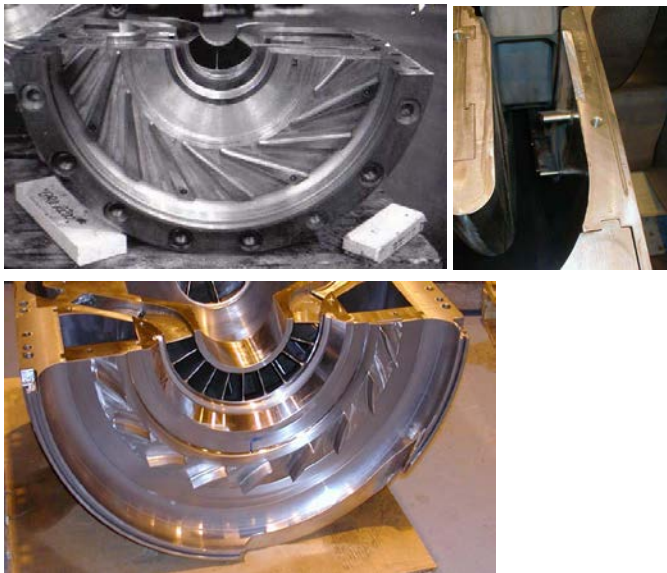

Figure 14. Diffuser Vane Styles

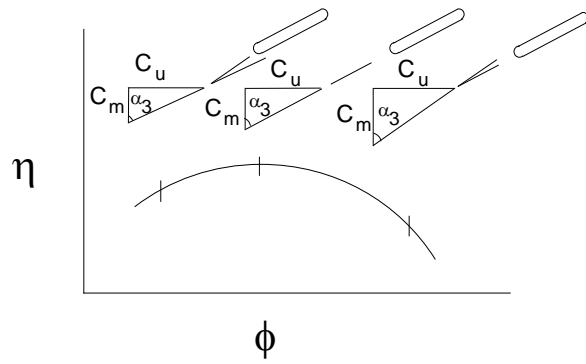

Figure 15. Diffuser Incidence Change for Varying Flow Rate

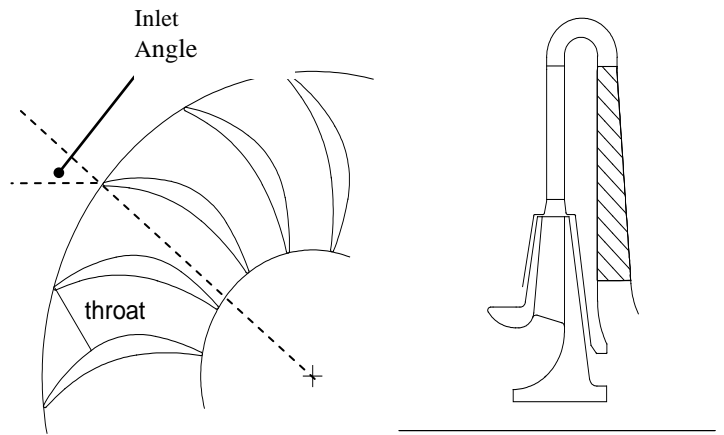

Figure 16. Return Channel Geometry

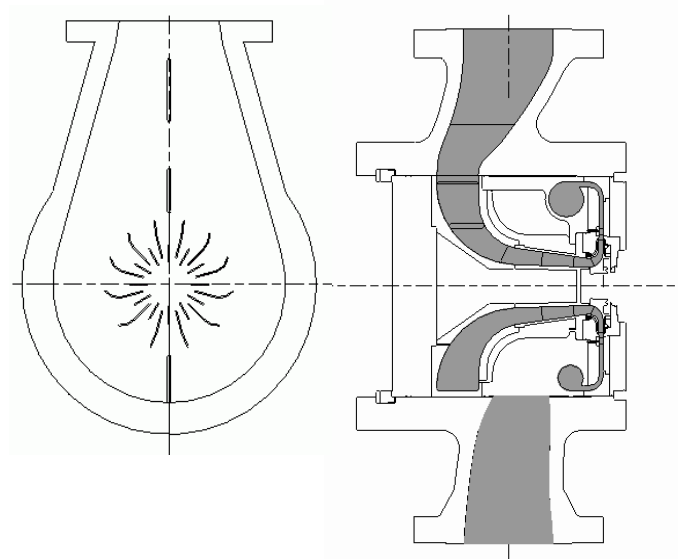

Figure 17. Compressor Inlet Section

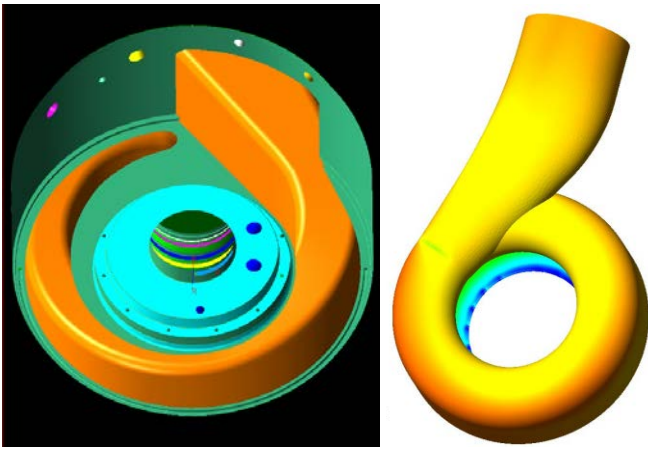

Figure 18. Discharge Volute / Collector

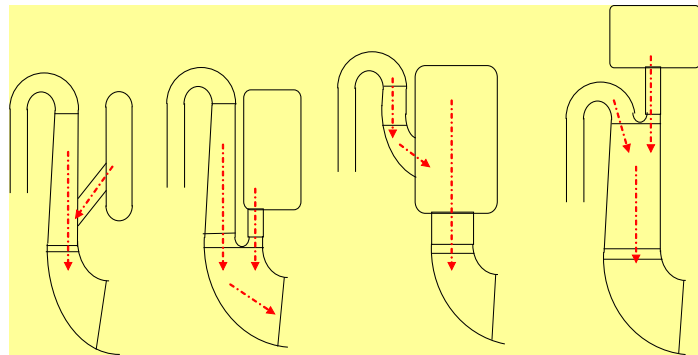

Figure 19. Incoming Sidestream Configurations

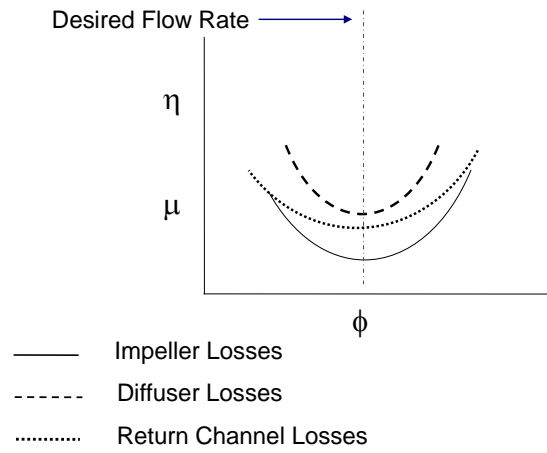
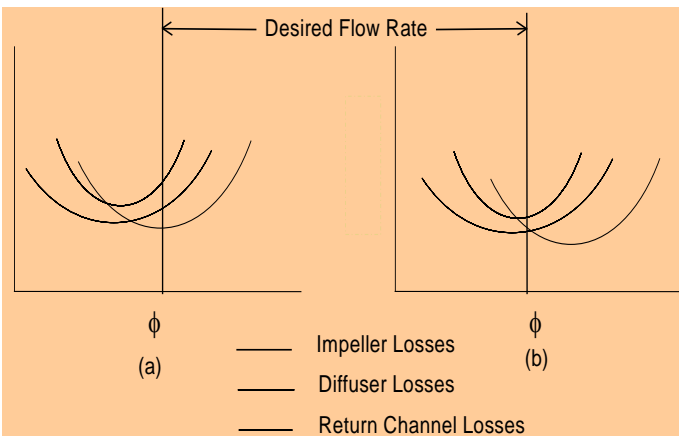

Figure 20. Bad Component Matching v. Good Component Matching

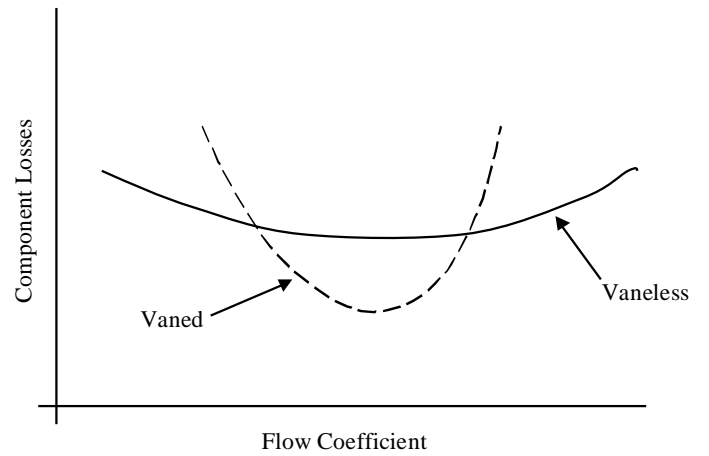

Figure 21. Vaneless versus Vaned Diffuser Losses

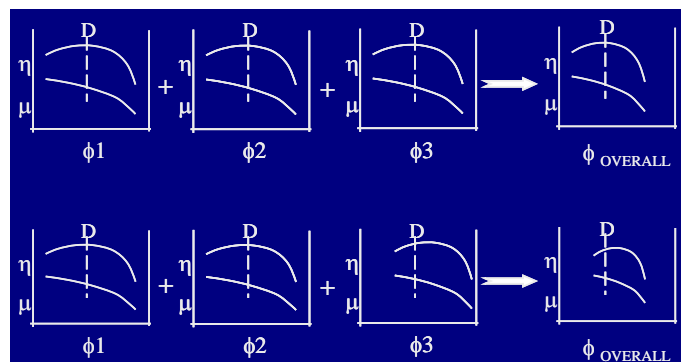

Figure 22. Stage Matching & Impact on Overall Performance

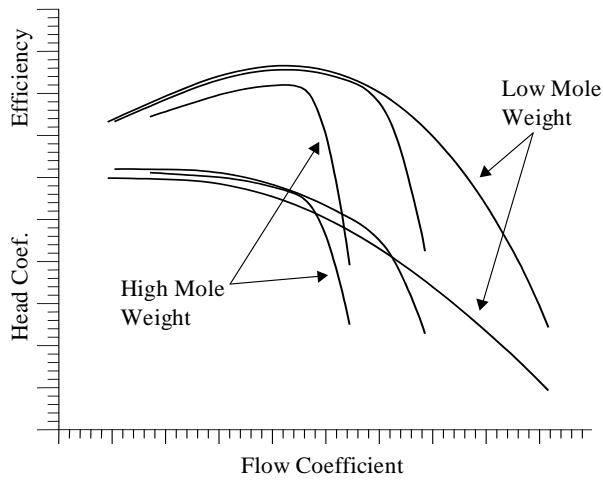

Figure 23. Variation in Stage Characteristics with Mole Weight (Fixed Stage Geometry at Constant Speed)

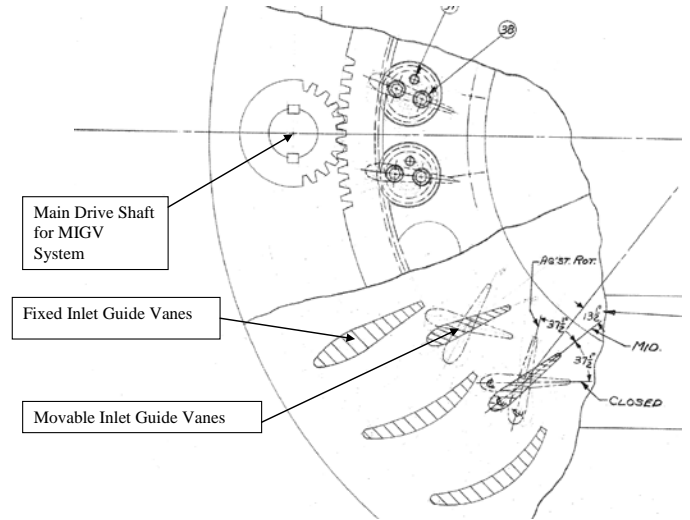

Figure 26. Movable Inlet Guide Vanes (MIGVs)

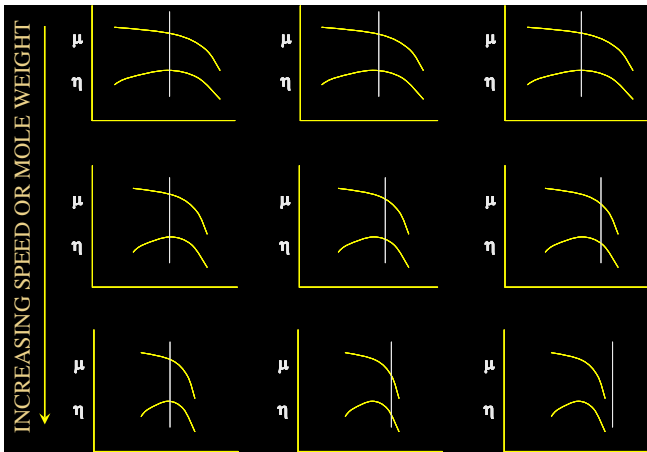

Figure 24. The Impact of Increased Speed or Increasing Mole Weight on Stage Matching

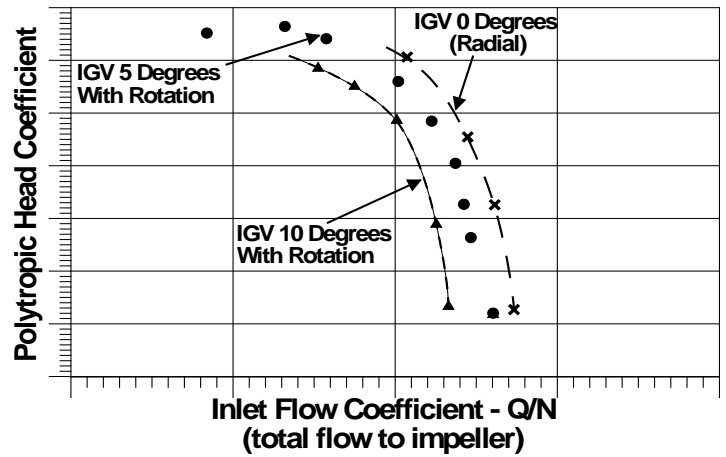

Figure 27. Impact of MIGVs on Stage Performance

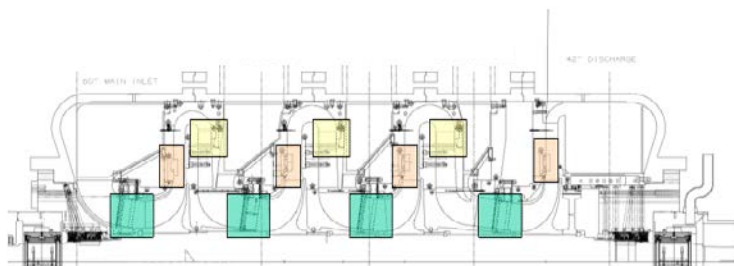

Figure 25. Desired Locations for Movable Geometry in Multi-Stage Compressor