



“MONITORING A TANDEM DRY GAS SEAL’S SECONDARY SEAL”

Glenn Schmidt

DGS Glenn, Owner
Houston, TX, USA/Douala Cameroon

Rich Hosanna

Manager of T28 Application Engineering
John Crane Inc.
Chicago, IL, USA

Vladimir Bakalchuk

Global Business Development Manager
Flowserve Corporation
Chicago, IL, USA

Jim McCraw

Senior Rotating Equipment Engineer
BP America Inc.
Houston, TX, USA



Glenn Schmidt is a DGS consultant working globally providing technical support for designing, servicing, repairing, troubleshooting and upgrades of compressors gas seals and systems. His 18-years of experience with gas seals includes instructing a Texas A&M Dry Gas Seal Systems Course and providing input as a member of the API 692 committee developing the standards for compressors gas seals and systems.



Jim McCraw is a Senior Rotating Equipment Engineer with BP America, Inc., Operation Efficiency Group in Houston, Texas. In his 28 years with BP and Amoco he has worked in machinery engineering, project support, plant maintenance, and machinery operation. In his position he is responsible for new equipment specifications, technology applications, research and development, and failure analysis for variety of centrifugal compressors, pumps, gas turbines, and gas engines. He holds BSEE from Finlay Engineering/University Missouri and is member of Nation Society of Professional Engineers.



Vladimir Bakalchuk – Global Business Development Manager at Flowserve Corporation. With over 35 years of experience in various fields of Oil and Gas Industry, Vladimir has spent over 20 years specializing in Dry Gas Seal / Rotating Equipment.



Rich Hosanna is Manager of T28 Applications Engineering for John Crane. In his 31 years at John Crane Rich has held many positions within Applications and Design Engineering with 25 years specific to Dry gas Seals. In his current position he is responsible for product & process standardization necessary to support our customer base around the Globe. Mr. Hosanna is also an active member of the API 692 task force created to address Dry gas Seal and Systems and is the holder of three US patents associated with the sealing industry.

Vladimir predicated his career in various technical capacities by Ukrainian Academy of Sciences, Mechanical Engineering Department of University of Calgary, Brown-Root-Braun, Nova Gas Transmission, Canadian Fracmaster, Revolve Technologies and John Crane. Vladimir is a registered Professional Engineer in the province of Alberta, Canada.

ABSTRACT

Rotating equipment and instrument engineers working with dry gas seals should attend this tutorial to increase their knowledge of methods for monitoring secondary seals. Over the last several years a number of compressor manufactures have issued safety notices concerning the industries inability to properly detect secondary seal failures in a tandem dry gas seal arrangement. When a secondary seal failure is undetected, the potential for an uncontrolled process gas release increases, leading to risks indicated in the safety notices issued. This Tutorial will examine the methods of monitoring the secondary seal in a tandem dry gas seal arrangement and the means to

detect a secondary seal failure.

The information and diagrams in this tutorial do not provide detail design requirements for the total seal monitoring system only methods currently being used for monitoring the secondary seal.

INTRODUCTION

In a beam style compressor dry gas seals are designed to seal against suction pressure during dynamic operation and settle-out pressure in a pressurized hold. The dry gas seal design is based on technology originally developed for air

bearings. The application of this technology to seals has resulted in a sturdy and versatile seal design.

Fundamentally the dry gas seal is a non-contact end face seal in which the sealing mechanism is comprised of two rings – one rotating and one stationary. The sealing is achieved by generation of a gap between the rotating and stationary face. Typical dry gas seal configurations applied in centrifugal compressors are Single, Double and Tandem (without or with intermediate labyrinth (Figure 1)).

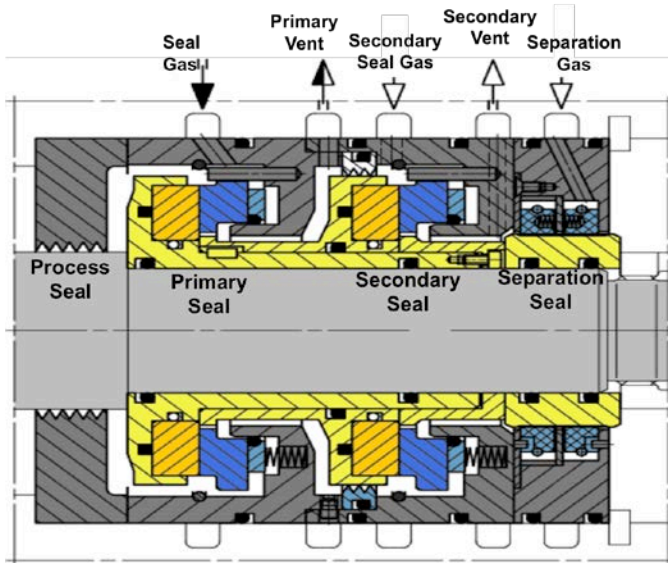

Figure 1. Dry Gas Seal with Intermediate Labyrinth

Since the subject of the tutorial is secondary seal monitoring, further discussion will be centered on the tandem seal configuration.

DRY GAS SEAL OPERATION

In a tandem seal arrangement two seals (primary & secondary) are placed in series. The primary seal is designed to take the full process pressure drop across the seal faces with minimal leakage routed to an appropriate vent location. The secondary seal in a tandem arrangement, that is also designed to take a full pressure drop across the faces, has two main purposes: first, during normal operation it contains primary seal leakage; and second, in the event of the primary seal failure, it serves as a backup seal to facilitate safe compressor shut down in case of primary seal failure.

The most commonly used dry gas seal configuration today is the tandem with intermediate labyrinth located between the primary and secondary seal. If buffered with a secondary seal gas (typically nitrogen), all primary seal leakage is directed out the primary vent, hence preventing primary seal gas (typically process gas) from venting through the secondary vent

To isolate gas seal cavity from the oil bearing cavity a separation seal is used. Dry nitrogen or air is provided to a separation seal to isolate the dry gas seal cavity from the oil bearing cavity and prevent oil ingress into the seal. Some seals

commonly used as separation seals are segmented carbon ring seals and split labyrinths.

To insure proper operation of dry gas seals, a support system is required. It is designed to condition and regulate the gas supplies and monitor the operation of the dry gas seals installed in a centrifugal compressor. This system can be divided into six basic modules:

- 1). Conditioning Module, that may be used in conjunction with any gas module.
- 2). Seal Gas Module
- 3). Primary Seal Vent Monitoring Module
- 4). Secondary Seal Gas Module
- 5). Secondary Vent Monitoring Module
- 6). Separation Seal Gas Module.

The figures illustrating the above modules in this tutorial are only examples. Many factors are taken into consideration to determine the correct methods and instrumentation used in dry gas seal support system for a given application.

DRY GAS SEAL SUPPORT SYSTEM

Seal gas is provided to the system, where it first undergoes conditioning to remove solid particulate, bulk liquids and if required, to raise the seal gas temperature in order to prevent liquid condensation formation between the sealing faces and in the primary vent cavity. This is achieved in the portion of the system referred to as a Conditioning Module, an example of which is shown on Fig. 2.

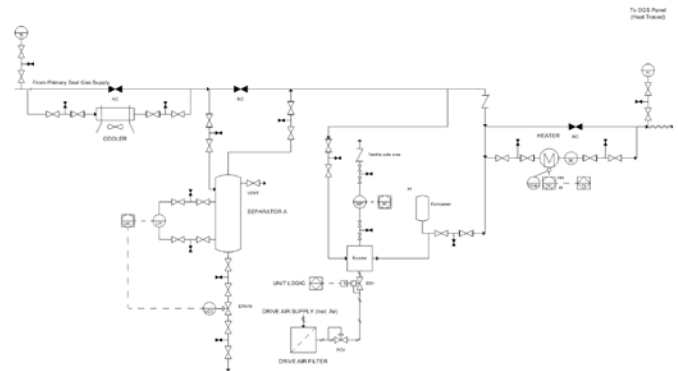

Figure 2. Conditioning Module

After leaving the seal gas conditioning, the seal gas passes through final filtration in the seal gas module as shown on Fig. 3. The seal gas is regulated by pressure or flow to provide the required flow to maintain clean operating environment for the dry gas seal.

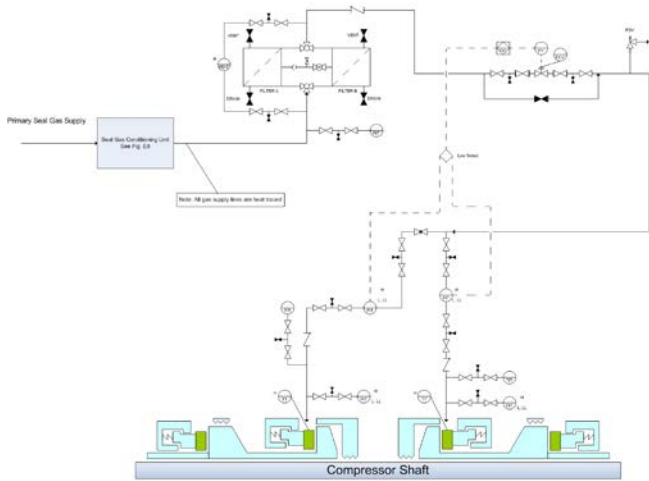

Figure 3. Seal Gas Module

Flow control is employed in the example, but regulating supply by differential pressure control can also be utilized. Flow to each seal cavity is monitored by a flow indicating transmitter, which provides the flow measurement to a Digital Control System (DCS). Based on these flow measurements, the DCS provides a signal to adjust position of the control valve to maintain minimum predetermined gas flow to the seals based on a low select principle.

The majority of the seal gas passes across the process seal back to the compressor process/suction. A small portion of the gas passes through the seal faces and exits as primary seal leakage. This leakage is monitored using a primary seal vent monitoring module (Fig. 4) to determine the health of the seal.

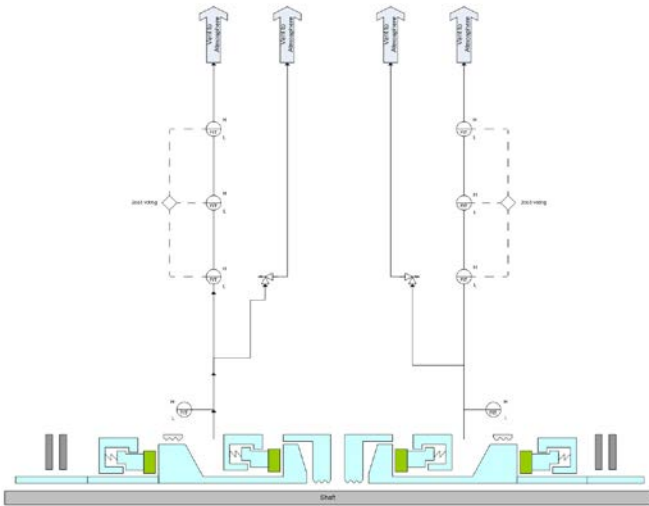

Figure 4. Primary Seal Vent Monitoring Module

Similar to primary seal gas module, the secondary seal gas module (Fig 5.) is used to regulate flow and pressure of the secondary seal gas. In the majority of cases nitrogen is used as the secondary seal gas. A very small amount of the secondary seal gas enters and passes through the secondary seal faces (> 0.2 scfm). The remainder flows across the intermediate labyrinth mixing with the primary seal leakage in the primary vent cavity. The combined gas then flows through the primary vent monitoring module and is vented to a specified safe

location.

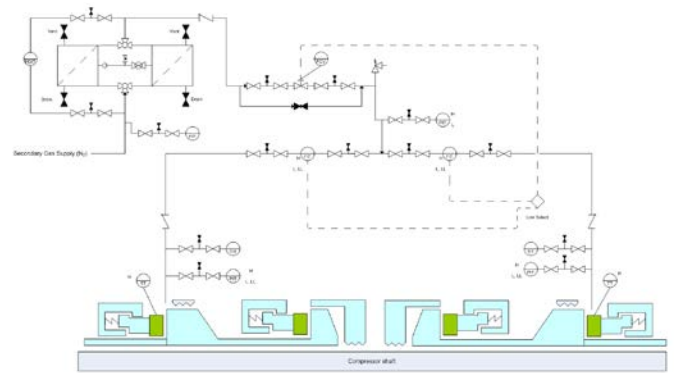

Figure 5. Secondary Seal Gas Module

The small amount of gas that passes through the secondary seal faces enters the secondary vent cavity where it mixes with the portion of separation seal leakage. The resultant flow is routed to the secondary vent. In the majority of applications, the secondary vent is not monitored and is routed to the “safe location” as shown in Fig. 6.

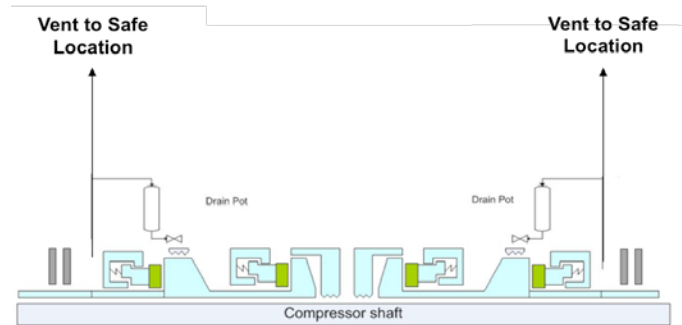

Figure 6. Secondary Vent Module

Similar to all the supplied seal gas streams, separation seal gas undergoes filtration, regulation and monitoring. Nitrogen or air is provided to the seal and regulated by either pressure, as shown in Fig. 7, or flow. Pressure control is applied to a segmented carbon ring bushings, while flow control is typically used with either segmented clearance carbon ring bushings or split labyrinth.

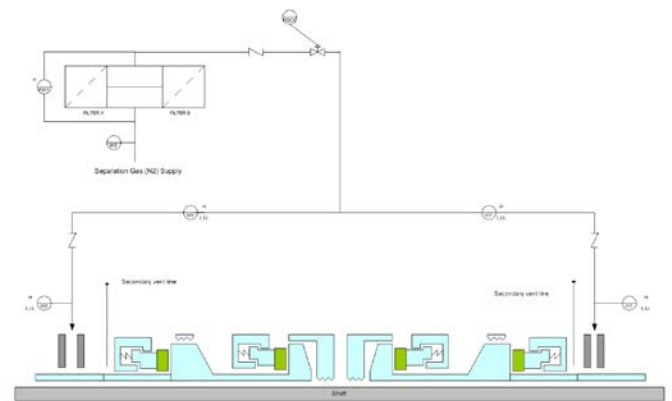

Figure 7. Separation Seal Gas Module

Proper selection and design of the dry gas seal support system is an important part of increasing dry gas seal reliability

and extending seal operating life.

TRADITIONAL SEAL MONITORING

Traditional seal systems were designed to monitor the leakage/flow from the primary seal. The system was designed with a “high” and “high-high” alarm to alert the operator of abnormal seal performance. The secondary seal’s leakage was not monitored, as the leakage across these seal faces was minimal. Furthermore, the leakage is routed to the same vent as the separation gas flow making it nearly impossible to quantify. Conventional thinking was that as long as the primary seal leakage was contained, the secondary seal was in good working condition. This methodology produces good results in high-pressure applications with sufficient leakage across the primary seal faces and in applications with secondary seal supply by allowing reliable reading with the provided primary vent monitoring arrangement. However, in low-pressure applications (or improperly designed vent systems) primary seal leakage was difficult to detect and a loss of containment by the secondary seal could have gone undetected.

CONCERNS WITH UNMONITORED SECONDARY SEALS

As previously described, the secondary seal’s two basic functions are to contain primary seal leakage and act as the backup seal facilitating safe shut down of the compressor in the event of a primary seal failure. When a secondary seal failure is undetected, the potential for an uncontrolled process gas release increases, leading to risks indicated in the safety notices issued.

CAUSES OF SECONDARY SEAL FAILURES

There are several potential factors that can lead to a secondary seal failure:

- Contamination by liquid and/or particulate (Fig. 8);
- Hang up of the seal as a result of seal installation;
- Improper installation of the threaded nut restraining seal axial movement;
- Reverse pressurization;
- Shaft misalignment;
- Reverse rotation of unidirectional seals;
- Slow compressor rotor turning speeds;
- Etc.

The effects of contamination impact the seal performance in two primary areas. The first area of concern is the lift geometry in the rotating seal face. Contamination can enter between the seal faces and accumulate in the groove

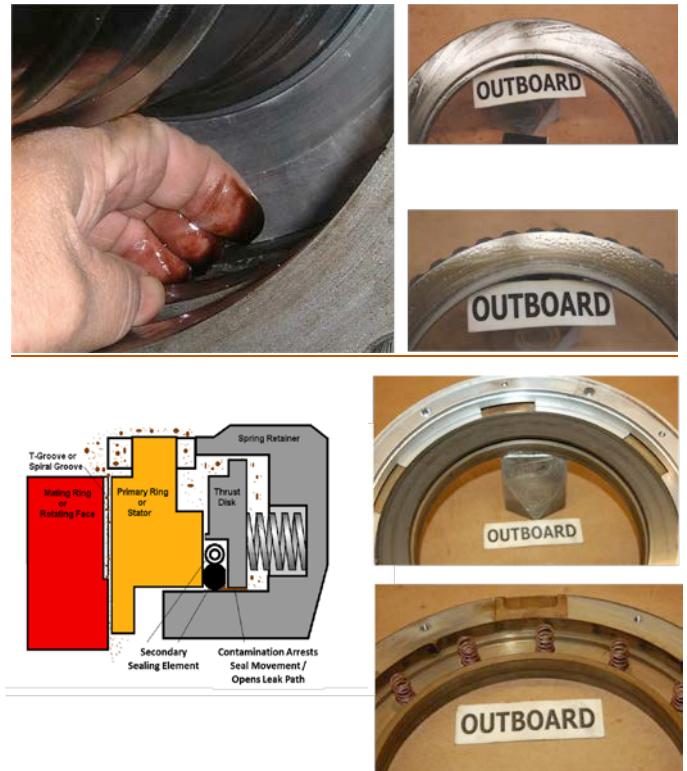

Figure 8. Contamination that Causes Secondary Seal Failures

geometry reducing the efficiency of the lift mechanism. This condition can lead to seal face contact, which can result in a catastrophic failure. The second area of concern is the tracking ability of the dynamic sealing element. Contamination can accumulate on the secondary sealing element and/or the sliding surface itself. This will increase the friction and inhibit the tracking action of the secondary sealing element. This condition can lead to seal face contact or a hang-up condition. Whether contact or hang-up takes place depends on the direction of relative movement between the compressor casing and the rotor.

Dry gas seal may “hang up” (stationary seal face movement is restricted) during installation. If not diagnosed, in case of a primary seal failure, the condition leads to process gas escape into the atmosphere.

Improper installation of a threaded nut that establishes seal’s axial position leads to seal face “swash” movement and may lead to a seal failure.

Compressor slow roll / ratcheting for extended period of time with seal faces being in contact may cause seal face deterioration leading to seal failure.

OVERVIEW OF BASIC LEAKAGE MONITORING METHODS

The health of a dry gas seal is defined by its leakage - gas escaping past the seal to the vent cavity. This leakage is

monitored by the means of either flow or pressure. A seal is considered failed when the flow or pressure reaches a predetermined value.

Typical instruments used for monitoring dry gas seal leakage are pressure transmitters and differential pressure transmitters in conjunction with an orifice (Fig. 9).

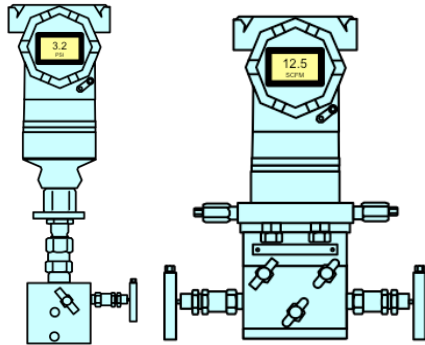

Figure 9. Pressure and Differential Pressure Transmitters

A pressure transmitter located upstream of the orifice is used to monitor seal leakage in applications with constant downstream pressure; for example, a vent routed to atmosphere. When flow through the orifice increases, the pressure upstream of the orifice will increase (see Fig 10). As the downstream pressure remains constant, differential pressure across the orifice and thus flow can easily be determined. When pressure reaches predetermined levels, it will identify a problem with the seal. These levels are known as a high and high-high leakage alarms. A high-high level alarm identifies that the compressor needs to be shut down due to an increased amount of gas escaping the seal.

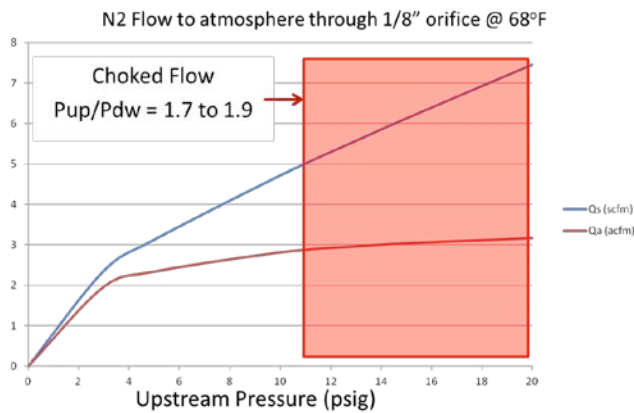

Figure 10. Gas Flow Through An Orifice

Another monitoring method utilizes a differential pressure transmitter measuring pressure drop across an orifice, which is proportional to the flow. This method allows more precise flow monitoring in applications with variable pressure downstream of the orifice. Candidates for this method are applications with vent systems routed to a variable pressure flare.

Instruments in these arrangements offer reliable monitoring in a relatively narrow range of values. It is not recommended to use pressure transmitters and differential pressure transmitters in conjunction with an orifice to measure flows close to the choke flow region on the upper end of the curve (see Fig 10). The low end of the measurement is limited to the flow with Reynolds Number below a minimum recommended (E.G., minimum Reynolds Number recommended for integral orifice assembly application is 10,000). This brings effective turn down ration (minimum reliably measured value to maximum reliably measured value) of these devices to approximately 1:10 at the most.

Other types of the devices use for flow monitoring are variable area flow meters and mass flow meters (Fig. 11). While variable area flow meters provide measurement range similar to pressure / pressure differential transmitter – orifice combination (1:10), mass flow meters provide a much wider range capabilities, approximately 1 to 100.

Variable area flowmeters use a float in a tapered tube to measure flow. As the flow increases, the float will move up the tube identifying flow volume by its position. Mass flow meters use various methods to measure gas flow through the instrument and are ideal for measuring wide ranges of flow.

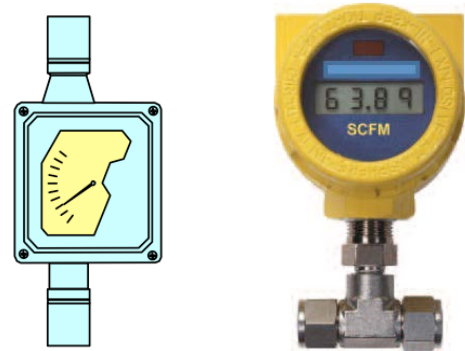

Figure 11. Variable Area and Mass Flow Meters

METHODS OF SECONDARY SEAL MONITORING

There are three locations where the secondary seal health can be monitored: primary vent, secondary vent and the secondary seal stationary face. A number of factors influence the selection of a monitoring method:

- primary seal leakage volume (a function of pressure, rpm and shaft diameter),
- presence of the secondary seal gas supply and its volume,
- type of separation seal used and its gas consumption, and
- maximum flare pressure.

Each of these factors varies based on application, so they must be accessed to determine which method would be the most advantageous.

MONITORING THE SECONDARY SEAL VIA MONITORING PRIMARY VENT PRESSURE

The most common method currently used in the industry for secondary seal monitoring is to monitor pressure in the primary vent. It is a proven method that has worked effectively in many applications.

This method of monitoring introduces a backpressure in the primary vent, which in turn applies pressure to the secondary seal. In the event of the secondary seal failure, the pressure in primary vent cannot be maintained as a portion or all of the primary vent flow passes through the secondary seal. Primary vent pressure falling below a predetermined value indicates a possible problem with the secondary seal and requires appropriate actions.

The method works well for sealing pressure of approximately 100 psig and above. Application of this method at sealing pressure lower than 100 psig may create a condition of primary seal reverse pressurization. To insure reliable seal operation, a positive differential across the primary seal is required. This means that the maximum vent cavity pressure attained during operation should always be less than pressure built in the cavity between the dry gas seal and process seal (usually a labyrinth). Maximum attainable operating vent cavity pressure is a sum of back pressure generated by devices used in the vent (pressure control valve, check valve, orifice or their combination) and pressure differential created by shutdown level vent flow through the monitoring orifice. It is recommended to evaluate utilization of this method for each individual case.

In some applications start-up procedure provides for the vent pressurization prior to compressor start-up, either by the secondary seal supply or a separate source of gas. This allows avoiding the introduction of time delay for the low pressure alarm as vent pressurization upstream of the control valve by primary seal leakage alone might take significant amount of time after the compressor startup. In this case possibility of seal reverse pressurization at the pressure level generated in the seal vent cavity should also be evaluated.

The following 3 options are used as a means of producing backpressure in the primary vent.

Option 1: Pressure Control Valve

Backpressure regulator or control valve is used to produce backpressure in the primary vent. Currently, this is the most widely used method to create backpressure in the primary vent due to high reliability of the valve performance.

To prevent influence of the flare pressure fluctuation on the pressure in the primary vent cavity, a regulator is set to maintain backpressure at or above maximum flare pressure level. Pressure transmitter's low alarm is set at a value below control valve set point. If pressure in the vent cavity cannot be maintained, usually due to the gas flowing through the

secondary seal, a low alarm will be actuated, indicating secondary seal failure.

Utilization of a control valve allows release of pressure build-up in the vent cavity. This becomes important if the possibility of primary seal reverse pressurization exists. It is achieved by providing a corresponding signal from DCS to open the valve. This might be required during compressor shutdown, start-up or settle out, i.e., at low compressor casing pressure condition.

Considering that the vent line includes a pressure control valve, pressure monitoring orifice and check valve that potentially can restrict the flow, sizing and selection of these elements to satisfy all possible flow conditions (high flow, shutdown level, etc.) becomes a complex task.

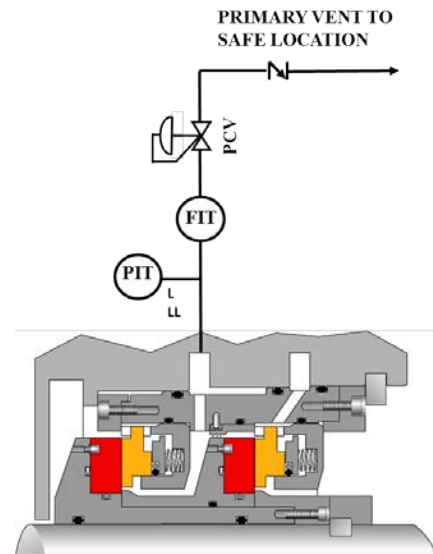

Figure 12. Secondary Seal Monitoring via the Primary Vent Utilizing a Pressure Control Valve

Option 2: Spring-loaded Check Valves

Primary vent backpressure is generated by a spring-loaded check valve.

This is a simple method to build pressure in the primary vent. Standard practice requires incorporation of check valves in vents routed to the flare to prevent back flow of unconditioned gas from flare lines into the seal and also to prevent communication between the separate vents in case of a primary seal failure. Therefore, incorporation of an additional device is not required.

Similar to the control valve set point, the check valve should be selected with a cracking pressure at or above maximum flare pressure, and pressure transmitter low alarm set below it.

Some check valve designs allow high pressure differential buildup at a high flow, which limits venting ability. This should be taken into account in check valve selection process.

Other important aspects to consider are check valve reliability and, similar to the pressure control valve, possibility of the primary seal reverse pressurization in case(s) of low pressure in the compressor casing.

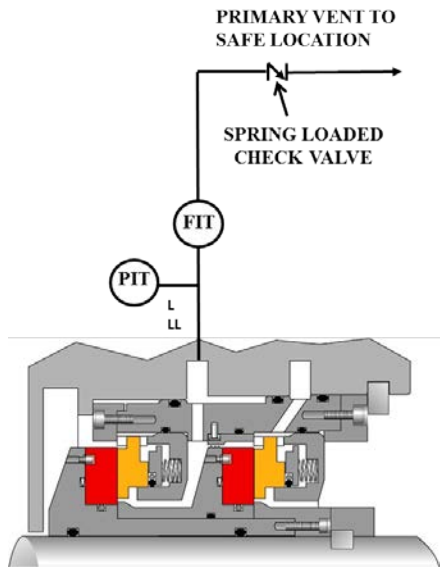

Figure 13. Secondary Seal Monitoring via the Primary Vent Utilizing a Spring Loaded Check Valve

Option 3: Restriction Orifice

In this option, an orifice is used to create a restriction in the flow path to produce backpressure upstream of the orifice. In a number of applications a flow-monitoring orifice may build enough pressure to reliably monitor secondary seal. The pressure level built in the vent cavity is a sum of the pressure differential build by primary vent flow and the pressure in line downstream of the orifice.

Pressure drop in the vent cavity below transmitter low alarm set point would indicate failure of the secondary seal. To produce reliable indication and to avoid false alarms, low alarm should be set at a value corresponding to fifty percent or less of the differential pressure drop produced by primary vent flow across the monitoring orifice at normal operating conditions. Depending on presence of the secondary seal supply, a delay on low pressure alarm might have to be introduced to compensate for the time required for the vent pressurization.

Based on the above requirements for the low alarm set point, utilization of this option is mostly limited to applications for seals with high leakage volume and secondary seal supply, i.e., high vent flow.

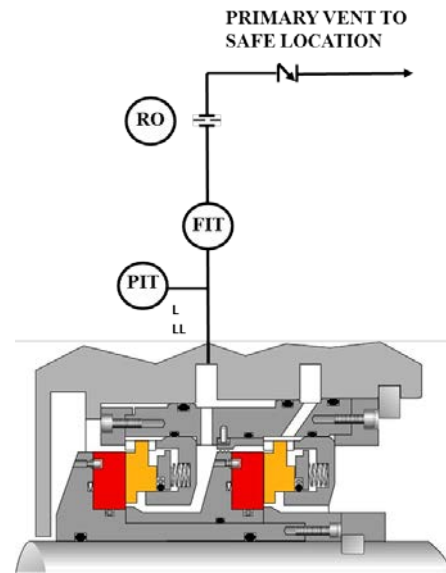

Figure 14, Secondary Seal Monitoring via the Primary Vent Utilizing a Restriction Orifice

MONITORING THE SECONDARY SEAL VIA MONITORING PRIMARY VENT FLOW

Another widely used method for monitoring the secondary seal via the primary vent is monitoring of the primary vent flow. The vent flow is monitored by a flow indicating transmitter or flowmeter. If the secondary seal fails, a portion or all of the primary vent flow passes through the secondary seal and out the secondary vent. A decrease or loss of the primary vent flow indicates a possible problem with the secondary seal and requires appropriate actions.

Since this method requires a device capable of monitoring a wide range of flows sometimes at a low level, a mass flow meter is a most suitable instrument for the application associated with low primary vent flow. Combination of the pressure transmitter / differential pressure transmitter in conjunction with the orifice is mostly suited and produces reliable reading in applications with higher vent flows. Reliability of the monitoring increases at higher leakage rates and the utilization of secondary seal supply.

To avoid false alarms, a set point for the flow transmitter low flow alarm may be set at a value corresponding to half of the secondary seal supply flow or less. For the applications without the secondary seal supply, it may be set at a point corresponding to half of the expected primary seal leakage flow or less.

This method of primary vent flow monitoring does not extend to low pressure applications without secondary seal supply as primary and secondary seal flows become close in magnitude, thus reducing resultant primary vent flow to almost

undetectable values.

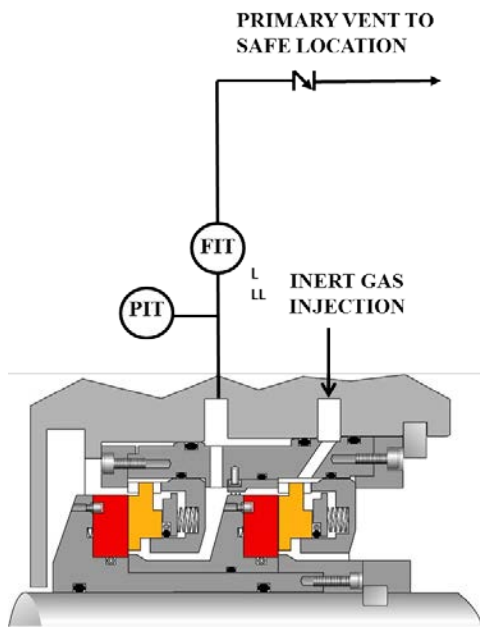

Figure 15. Secondary Seal monitoring Utilizing Primary Vent Flow Monitoring.

MONITORING THE SECONDARY SEAL VIA SECONDARY VENT

Another means of monitoring the secondary seal is via the secondary vent. According to common practice, a restriction in the secondary vent should be avoided for two key reasons:

- In the event of a catastrophic seal failure, a restriction in the secondary vent can result in a pressure increase in the secondary vent cavity that would direct process gas through the separation seal into the bearing cavity;
- Failure of separation seal in cases where secondary vent flow is restricted can lead to the secondary seal reverse pressurization.

Given this requirement, there are three methods of secondary seal monitoring via the secondary vent that do not place restrictions in the secondary vent line: pressure, flow or detection of a process gas.

Option 1: Secondary Vent Pressure Monitoring

If the secondary seal fails, the flow in the secondary vent will increase by the amount of primary vent flow passing through the secondary seal. Increased flow might raise the pressure in the secondary vent indicating a possible problem with the secondary seal.

Practically, this pressure increase in unrestricted secondary vent lines is undetectable. The only case when the secondary seal

failure can be reliably diagnosed by this option is when the secondary seal failure has been preceded by the primary seal failure and process gas is flowing into the secondary vent.

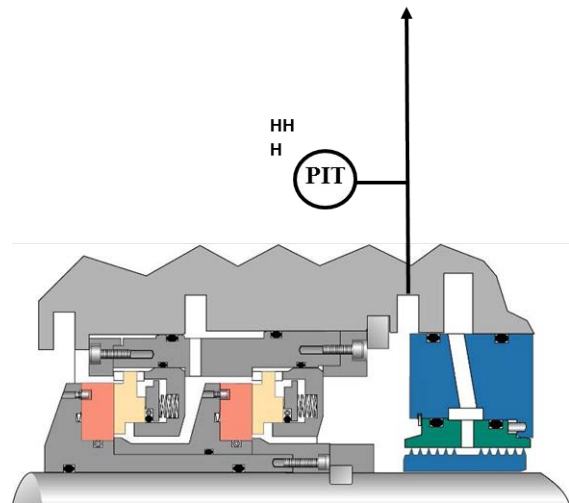

Figure 16. Secondary Vent Pressure Monitoring

Option 2: Secondary Vent Flow Monitoring

If the secondary seal fails, the secondary vent flow will increase. This increase in flow indicates a possible problem with the secondary seal and requires appropriate actions.

To effectively use this method, the primary vent flow should be compared to the separation seal leakage into the secondary vent. To be able to detect the secondary seal failure, separation seal flow fluctuation should be much less than primary vent flow. In other words, the separation seal leakage flow into the vent should be constant to a certain degree. This flow stability can be achieved by utilization of clearance type seals.

Based on the above, this option cannot be applied to seals with a low primary seal leakage without secondary seal supply, as addition of the minute primary vent flow will not produce a reliable change in the secondary vent flow reading.

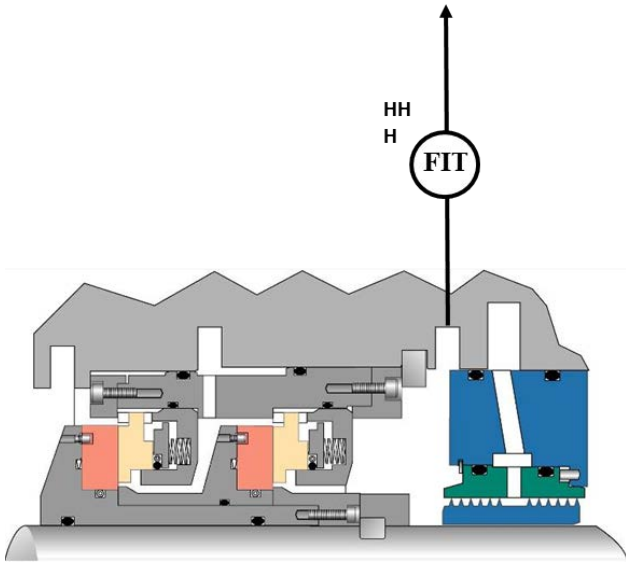

Figure 18. Secondary Vent Flow Monitoring

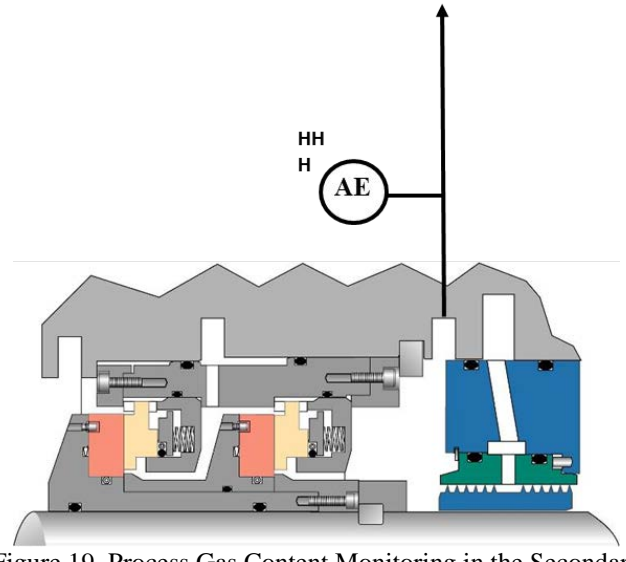

Figure 19. Process Gas Content Monitoring in the Secondary Vent

Option 3: Process Gas Content Monitoring

If the secondary seal fails, portion or all primary vent flow is redirected into the secondary vent. Since primary vent flow contains primary seal leakage, a process gas will be present in the secondary vent.

A gas detector is used to measure hydrocarbon content in the secondary vent. Detection of process gas presence in the secondary vent may identify a secondary seal failure.

Over the years, experience with application of this method showed high number of false alarms. The alarms were triggered mostly due the presence of minute traces of oil vapor in the secondary vent. Also, reliability of the devices was often questioned. Devices themselves required high degree of maintenance.

In applications without the secondary seal supply, secondary seal leakage is process gas. Therefore, this method cannot be used.

MONITORING SECONDARY SEAL VIA SEAL FACE TEMPERATURE

Option 1: Seal Face Temperature

Contact between the rotating and stationary face or presence of liquid between the seal faces generates heat. When stationary seal face temperature increases above a defined set point it signals an imminent secondary seal failure. When the stationary seal face temperature decreases below a defined set point it identifies open seal faces. So a high temperature or a low temperature, i.e., a temperature outside the defined operating range indicates a possible problem with the secondary seal and requires appropriate actions. Set points for the high and low alarms are typically established in the field.

Utilization of the method in some seal cavity designs is complicated, as routing of the thermocouple wire becomes cumbersome.

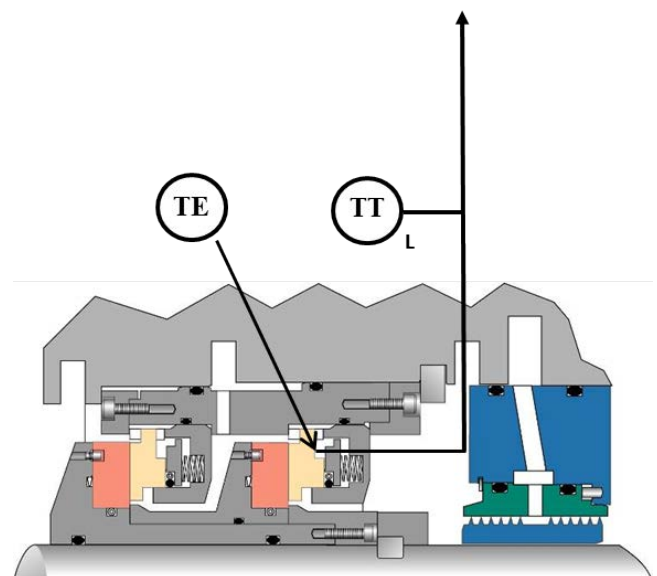

Figure 20, Temperature Monitoring of Secondary Stationary Seal Face

SECONDARY SEAL MONITORING CHALLENGES FOR LOW PRESSURE APPLICATIONS

Applicability of the monitoring methods and their options to low pressure applications have been examined throughout this tutorial. If sufficient backpressure in the primary vent cannot be maintained, or backpressure results in reverse pressurization of the primary seal, or secondary vent monitoring is deemed unreliable, then face temperature monitoring or the application of a double seal should be considered. Since, the double seal gas supply pressure is always 30 to 50 psi higher than the process pressure or the flare pressure, applying double seals eliminates concerns with seal reverse pressurization.

CONCLUSIONS

In summary, there are advantages and disadvantages to any method of secondary seal monitoring. The best method must be selected on the basis of the actual application. Consideration must be given to the gas being sealed, the sealing pressure, flare pressure and type of separation seal. Working closely with seal and compressor manufacturers during the design phase and HAZOP will enable selection of the best method for the application.

NOMENCLATURE

PT	= Pressure Transmitter
PDT	= Differential Pressure Transmitter
FIT	= Flow Indicating Transmitter
PVC	= Pressure Control Valve
RO	= Restriction Orifice
TE	= Temperature Element
TT	= Temperature Transmitter
AE	= Analyzing Element