

**NEW PROCEDURE FOR LOUDNESS ASSESSMENT AND NOISE
ATTENUATION OF VENTILATION KITCHEN RANGE HOODS**

A Thesis

by

ANTONIO VALDEZ GOMEZ

Submitted to the Office of Graduate and Professional Studies of
Texas A&M University
in partial fulfillment of the requirements for the degree of

MASTER OF SCIENCE

Chair of Committee,	Michael Pate
Committee Members,	Yong Joe-Kim
	Karen Vierow
Head of Department,	Andreas Polycarpou

May 2015

Major Subject: Mechanical Engineering

Copyright 2015 Antonio Valdez Gomez

ABSTRACT

The Home Ventilating Institute (HVI) created a standard to specify the procedure for sound quality testing of mechanical ventilation equipment. This standard contained a procedure for performance, reliability, and accuracy based on a full assembly loudness assessment. This thesis provides a new generic component loudness assessment procedure that can be utilized to identify and reduce the noise radiating from kitchen range hoods based on an individual component loudness assessment. With these evaluations, design improvements are implemented to help reduce the outgoing noise from the range hood that may cause hearing loss or high stress.

Four different range hoods were tested across the 24-1/3 octave frequency bands using the new component loudness assessment procedure. The kitchen range hoods tested include two centrifugal-flow fans and two axial-flow fans for ventilation. Each range hood includes basic component design differences in the damper, grille, and enclosure. The results show that in all but one case the damper caused an increase in the overall loudness by 10% at high speed and as much as 70% at low speed. In addition it has been observed that the addition of the grille can either reduce the loudness or increase the loudness depending on design features.

Using the information gathered from the component loudness assessment, practical low-cost noise attenuation techniques are formulated and implemented in order to reduce overall loudness. The primary goal of noise attenuation (or noise reduction) is to diminish the overall loudness to a comfortable level. Using the techniques formulated,

vibration and aerodynamic induced noise have been reduced across all speeds of the range hood by as much as 15%. The greatest reduction was observed at high speed with a reduction of 2.17 sones, while mid and low speed were able to archive a reduction of 0.89 sones and 1 sone respectively.

The new procedure gives improved insight into individual components contribution to overall loudness, and provides better intuition on how to reduce the outgoing noise. A reduction in noise should improve the sound quality indoors and have a positive effect on consumer health and quality of life.

NOMENCLATURE

IECC	International Energy Conservation Code
IEQ	Indoor Environmental Quality
HVI	Home Ventilating Institute
ASHRAE	The American Society of Heating, Refrigerating and Air Conditioning Engineers
ANSI	American National Standards Institute
Sone	Unit of loudness
dB	Sound Pressure unit (decibel)
L_p	Sound Pressure Level (dB)
L_w	Sound Power Level (dB)
BKG	Background Noise

TABLE OF CONTENTS

	Page
ABSTRACT	ii
NOMENCLATURE	iv
TABLE OF CONTENTS	v
LIST OF FIGURES	vii
LIST OF TABLES	ix
CHAPTER I INTRODUCTION	1
CHAPTER II BACKGROUND	3
Sound Quality	4
Noise	7
Noise Control	8
Literature Review	10
CHAPTER III THEORY	12
Sound Pressure, Sound Power	12
Sone Rating	14
Sone Calculation	17
CHAPTER IV EXPERIMENTAL APPARATUS	21
Sound Field Measurements	21
Semi-Reverberant Chamber Set-up	22
Instrumentation	29
CHAPTER V EXPERIMENTAL TESTING PROCEDURE	35
Sound Quality Measurement Process	35
New Component Loudness Assessment Procedure	39
Noise Attenuation Procedure	40
CHAPTER VI RESULTS AND DISCUSSION	43

	Page
Loudness Assessment	43
Axial Fans	45
Centrifugal Fans	49
Acoustic Loudness Signature.....	54
Noise Attenuation	58
Acoustic Absorption and Structural Vibration Noise Reduction Techniques.....	59
Aerodynamic Noise Reduction Techniques	66
Combined Sound Reduction Techniques	74
CHAPTER VII CONCLUSION	81
REFERENCES	82

LIST OF FIGURES

	Page
Figure 1: Equal Loudness Contours for Pure Tones (ISO R226)	6
Figure 2: Zero Sone Threshold for the Semi-Reverberant Chamber	15
Figure 3: Part 1 of the Equal Loudness Index Table (ANSI S3.4-1980)	16
Figure 4: Part 2 of the Equal Loudness Index Table (ANSI S3.4-1980)	17
Figure 5: Schematic of Semi-Reverberant Testing Chamber Used at the REEL.....	23
Figure 6: Sound Chamber Six Microphone Array	25
Figure 7: Sound Chamber Fan Mounting Area	26
Figure 8: Condenser Microphone Design (Everest, A.F. 2001).....	30
Figure 9: PULSE Labshop Software Interface.....	37
Figure 10: Microsoft Excel Database Storage.....	38
Figure 11: Axial Fan Kitchen Range Hoods Used for Testing	45
Figure 12: Centrifugal Fan Kitchen Range Hoods Used for Testing	49
Figure 13: Loudness Frequency Response for Fan 13_CC22.....	55
Figure 14: Fan 13_CC22 High Speed Response with Reference Case.....	56
Figure 15: Fan 13_CC22 Mid Speed Response with Reference Case	57
Figure 16: Fan 13_CC22 Low Speed Response with Reference Case	58
Figure 17: Damper Discharge Modification (Code: DMP).....	60
Figure 18: Range Hood Enclosure Modification (Code: ENC)	61
Figure 19: Vibration Isolation Pad between Motor and Enclosure (Code: MOT).....	62
Figure 20: Double Vibration Isolation Pad Schematic (Everest, A.F. 2001).....	63

	Page
Figure 21: Grille Modification by Adding Anechoic Foam (Code: BAF).....	63
Figure 22: Airflow Guide Applied to Damper Outlet (Code: EXG).....	68
Figure 23: Duct Discharge Extension Modification (Code: DDE).....	69
Figure 24: Grille Guide Adjustment (Code: BAFA).....	70
Figure 25: Baffle Filter Guide Schematic	72
Figure 26: Loudness Frequency Response for Airflow Guide.....	73
Figure 27: Noise Reduction Combination Test.....	75
Figure 28: Loudness Reduction Response for Fan 13_CC22 at High Speed.....	77
Figure 29: Loudness Reduction Response for Fan 13_CC22 at Mid Speed	78
Figure 30: Loudness Reduction Response for Fan 13_CC22 at Low Speed	79
Figure 31: Dominant Frequency Reduction	80

LIST OF TABLES

	Page
Table 1: Sound Chamber Floor Construction Materials	28
Table 2: Sound Chamber Walls Construction Materials.....	28
Table 3: Sound Chamber Roof Construction Materials	29
Table 4: Instrumentation Used for Sound Quality Testing	33
Table 5: Sound Testing Equipment Uncertainty	34
Table 6: Axial Fan Range Hood Specifications	46
Table 7: Axial Flow Loudness Results at High Speed.....	47
Table 8: Axial Fan Loudness Results at Low Speed.....	48
Table 9: Centrifugal Fan Range Hood Specifications.....	50
Table 10: Centrifugal Fan Loudness Results at High Speed.....	51
Table 11: Centrifugal Fan Loudness Results at Mid Speed	52
Table 12: Centrifugal Fan Loudness Results at Low Speed	52
Table 13: Component Effect on Overall Loudness for Each Range Hood	53
Table 14: Noise Attenuation Phase 1 Modifications.....	60
Table 15: Noise Attenuation Results from Phase 1.....	64
Table 16: Noise Attenuation Phase 2 Modifications.....	67
Table 17: Noise Attenuation Results Phase 2	71
Table 18: Noise Attenuation Results Phase 3	76

CHAPTER I

INTRODUCTION

Acoustic engineers have been concerned with the topic of indoor environmental quality (IEQ) over the past several decades as building occupants demand to have a better living experience indoors. IEQ comprises the conditions inside a building relating to air quality, sound quality, lighting quality and thermal quality. The most extensive research has been associated with thermal quality and air quality comfort. The topic of sound quality comfort has only recently been studied and several standards fail to cover the topic. Sound quality must be considered in building design standards in order to further improve the quality of life for building occupants and help reduce noise pollution indoors.

The Riverside Energy Efficiency Laboratory (REEL) performs sound quality tests on home appliances whose functional purpose is to provide mechanical ventilation. Mechanical ventilation is a system that is designed to mechanically exchange indoor air with outdoor air when operating continuously or through a programmed intermittent schedule (IECC 2012). REEL predominantly sound quality tests two types of appliances, bathroom/utility fans and kitchen range hoods. Testing is done in accordance with the Home Ventilating Institute (HVI) Loudness Testing and Rating Procedure standard 915. The test chamber used to conduct the sound quality tests is a semi-reverberant sound chamber. The purpose of the test is to verify loudness ratings for ventilation equipment and certify Energy Star rated products.

This thesis provides a new general component loudness assessment procedure that can be utilized to identify and reduce the noise radiating from kitchen range hoods based on an individual component loudness assessment. The new generic component loudness assessment utilizes the sound quality measurement process defined by HVI standard 915. All sound quality measurements performed are in accordance with the standard to ensure accurate and repeatable results. The new procedure will help identify noise contributing components that can be modified to reduce the noise radiating from kitchen range hoods. With these evaluations, sustainable design improvements are implemented to help reduce noise pollution indoors that may cause hearing loss or high stress.

Chapter I provide an introduction to the study. Chapter II discusses the motive for the work presented and provides general background information on sound quality and noise. Chapter III discusses the acoustic principals applied in this thesis along with the calculation used to obtain the sone rating. Chapter IV discusses the semi-reverberant sound chamber layout along with the instrumentation installed inside and outside the room. Chapter V discusses the testing procedure for the new generic component assessment including the details of noise attenuation. In addition Chapter V provides the HVI loudness rating measurement process followed. Chapter VI discusses the loudness assessment and noise attenuation results, and Chapter VII provides the conclusion.

CHAPTER II

BACKGROUND

Since the industrial revolution, building designers and engineers have been influenced by demands for higher living standards and increased IEQ. Newly developed design considerations protect human health, improve quality of life, and reduce stress. Poor indoor IEQ can lead to poor health, communication disturbance, and productivity problems. Recently, the U.S Green buildings council implemented the Leadership in Energy and Environmental Design (LEED) certification program to promote the importance of IEQ in green building design.

One of the main concerns for IEQ is indoor air quality. Extensive research and engineering design has been concerned with the improvement of air quality because building-related illness (BRI) and Sick-building syndrome (SBS) continue to rise. The International Energy Conservation Code (IECC) along with the American society of heating, refrigerating, and air-conditioning engineers (ASHRAE) require proper building ventilation to help remove toxic volatile organic compounds (VOC's), carbon monoxide and other hazardous airborne particles. Although the concept of building ventilation has been discussed due to improvement of indoor air quality, there has been little update on the psychoacoustic evaluation of mechanical ventilation and its influence on the quality of sound indoors.

Mechanical ventilation is a necessary requirement for commercial and residential building design, and it is one of the provisions in the IECC 2012 and ASHRAE 62.2 for

improved IEQ. The ventilation code in IECC 2012 and ASHRAE 62.2 appear to be an encouraging transition toward better indoor comfort; however, the ventilation requirement limits its scope to indoor air quality due to the volumetric flow rate and efficacy for performance ratings. One additional factor that influences indoor comfort is the extraneous noise that is given off by the ventilation system. The building codes and standards fail to consider sound quality as a necessary performance criterion that affects consumer indoor comfort. The quality of sound should be considered in building codes in order to further increase the comfort of people indoors. Noise from the ventilation fan can be influential to hearing loss and psychological stress (Waye, K. P. and R. Rylander. 1997) if not regulated.

Sound Quality

Psychoacoustics is the field of study that establishes a link between physical and subjective evaluations of sound. Physical quantities of a sound source, or stimuli, can be described with measurements such as sound pressure level, sound power level, frequency, wavelength and duration. Physical stimuli correlate to subjective hearing sensations, such as loudness, tone, harshness and pitch. Sound quality is a psychoacoustic hearing sensation used to estimate the acoustic acceptability of a space to occupants (ASHRAE. 2005). Loudness measurements quantify sound quality and can lead to more precise results than magnitude estimations alone. Loudness levels help judge if a sound is soft or loud and gives a more comprehensive way to compare human response to noise.

Loudness is a subjective response to the amplitude of sound (ASHRAE. 2005) in that it measures how loud or soft a sound is perceived by a human ear. Loudness measurements lead to a more precise result than magnitude estimations alone because it accounts for the variations in perceived loudness as a function of frequency. Depending on the frequency of a tone, sound will have a different loudness given the same sound pressure level. This is represented by the equal loudness contour plot shown in Figure 1. Equal loudness contour lines represent the sound pressure level required at any frequency in order to give the same apparent loudness of a 1 KHZ tone. The loudness level takes into account the equal-loudness contour lines and demonstrates how the sound energy is distributed as a function of frequency. From the figure, it can be seen that human ears are most sensitive to sounds between 2 kHz and 5 KHz, and least sensitive to low and very high frequencies. A sound pressure level of 10 dB at 1 KHz is equal in loudness to a sound pressure level of 60 dB at 30 Hz.

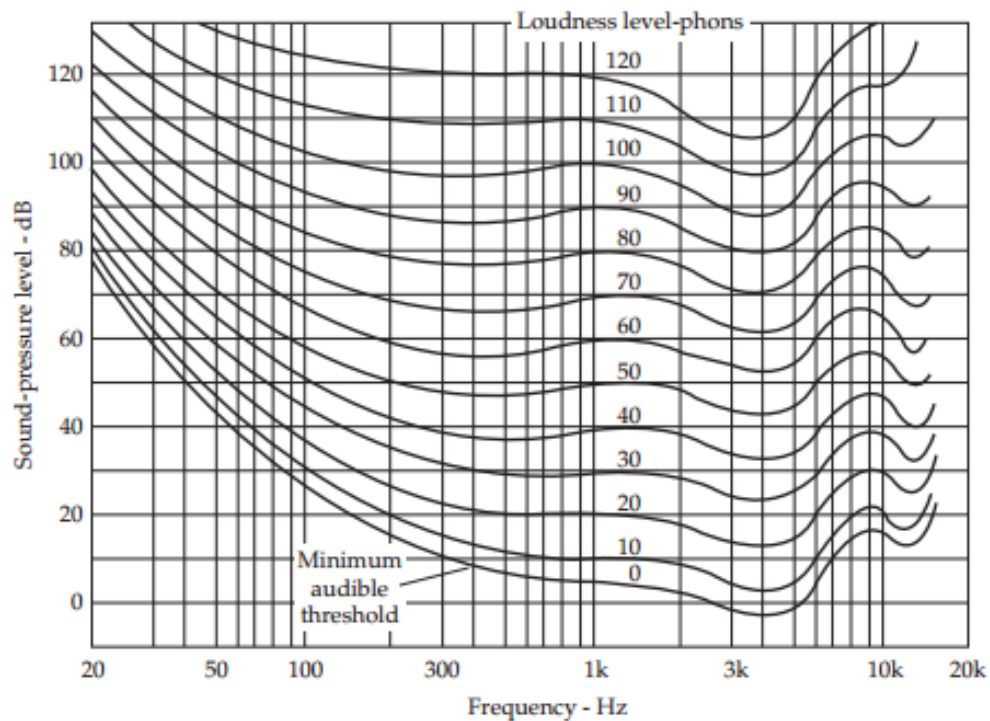

Figure 1: Equal Loudness Contours for Pure Tones (ISO R226)

Human ears can detect very small pressure variations; however, they cannot sense sounds softer than the motion of air particles on the eardrum, which is known as the threshold of hearing. Conversely, at extreme loudness level typically above 140dB, a tingling sensation or even pain can be felt to help protect the sensitive stereocilia nerves from damage, which is known as the threshold of pain. The frequency range of human hearing is typically 20-20,000 HZ with the upper range depending on age and noise exposure. At lower frequencies, the sound pressure level has to be relatively higher compared to the higher frequencies. As the frequency increases to 8,000 Hz, the sound

pressure level needed to perceive loudness decreases and then this trend reverses above 8,000 Hz.

Noise

Humans observe sound by detecting variations in pressure that travel through the air as particles interact with each other. Due to particle motion, the pressure wave strikes the human eardrum causing electrical discharges to be sent to the brain creating the sensation of sound. The human ear is typically divided into three main functional areas that allow humans to define sound. First the outer ear, also called the pinna, gathers the sound and aids in directionality detection so that the resultant sound pressure on the eardrum allows the brain to interpret direction and content of sound. The sound is transmitted through the ear canal in order to amplify the sounds as it reaches the eardrum. The mid ear area transfers sound energy from the eardrum, represented by vibratory motion, to the fluid of the inner ear (Everest, A.F. 2001). Three bones in the mid ear act as an ossicular chain to form a mechanical linkage between the eardrum and the oval window, which is in contact with the inner ear where hearing actually takes place. The vibrations transmitted through the bones of the mid ear are converted into pressure fluctuations in the cochlear fluid {Crocker, M. 2007} with the excited fluid stimulating hair-like stereocilia nerves on the basilar membrane that convey signals to the brain in the form of neuron discharges.

Noise is defined as a loud or unwanted sound that causes a disturbance (Waye, K. P. and R. Rylander. 1997), which includes distractions and annoyances that can be harmful to activities such as work, rest, study and entertainment. A sound does not have

to be considered loud in order to be defined as noise; rather the only requirement is for the sound to be unwanted. The state of being acoustically satisfied involves contentment and satisfaction with acoustic conditions of the build environment (Waye, K. P. and R. Rylander. 1997).

Noise pollution is a physical and psychological problem that has several undesired effects such as damaged hearing, increased heart rate, troubled sleep, reduced efficiency and interference with communication. The primary motivation for most companies or manufacturers to improve sound quality is cost, meaning that consumers are willing to pay extra for quiet mechanical ventilation equipment in order to improve sound quality indoors.

Noise Control

Noise control, also called noise reduction or attenuation, is the process of obtaining an acceptable noise environment for a particular observation point or receiver {Crocker, M. 2007}. Typically acoustic noise systems are categorized into three main elements that include the Source, Path, and Receiver. Noise control techniques can be applied to any one or all of the three elements. For instance in some situations it might be easiest to reduce the noise from the source, while in others it might be superior to force the receiver (occupants) to wear hearing protection. In most situations, the noise source is difficult to identify and the attention shifts to the path of noise transmission. Cost effective treatment dictates what type of noise control technique is utilized for the various system elements. The main concern with noise control is to make a sound wanted or to make the sound go away completely.

Noise control is important when trying to improve the sound quality indoors. A reduction in noise results in a quieter environment and increases the comfort of occupants indoors. A quiet building exhibits 40 to 45 dB(A) while a noisier environment of 60 to 65 dB(A) requires occupants to talk louder and can add to physiological stress. The three types of sound reduction are passive control, active control, and design control.

The basic idea behind noise control is preventing sound waves from getting to a person's ear. It is common to find equipment lined with acoustic foam or a noise barrier for noise control. The foam absorbs sound energy, while the barrier prevents residual noise from escaping an enclosure. This type of noise control is commonly associated with passive noise attenuation. The limitations with passive control are with the low frequency noise and interference of ventilation air movement. Acoustic foam is less efficient on low-frequency noise, which can be most irritating. In addition the acoustic foam can interfere with the amount of air flow in ventilation equipment since optimal results of noise control require sealing the noise source to allow maximum absorption of sound energy.

Another noise attenuation strategy is active noise control. Active noise control involves the production of an opposite sound wave (anti-noise) that cancels out the unwanted sound (silenced simplified). The signal must have the same amplitude of the noise, but 180 degree out of phase from the signal to cancel out the unwanted noise. This type of noise control can be complex to implement, and the level of attenuation is dependent on the accuracy of the system in producing the anti-noise at the proper

amplitude and phase. A typical active control set up include a reference microphone that captures the source noise, a digital control signal generator that produces a counter phase signal and sends it to a speaker that transmits the anti-noise signal to the environment. There is also an error microphone at the point of noise attenuation that provides information to the controller, allowing it to make corrections to the reduction signal.

Lastly design control can also be utilized for effective noise attenuation. Much research has been conducted in reference to noise reduction of centrifugal fans found in many mechanical ventilating range hoods. Design modifications to the voltage tongue and the squirrel cage fan blades have proven noise reduction can be achieved. Simple design modifications such as the inclusion of vibration isolation pads or repositioning of the air flow damper can reduce the noise significantly.

Literature Review

A literature review, which focused mainly on standards, was performed in support of the project report herein. Currently the Home Ventilating Institute (HVI) Standard 915 provides a procedure to certify and rate the loudness of mechanical kitchen range hoods based on a full assembly assessment. HVI also provides third-party performance results for manufacturer verification to meet the Department of Energy's (DOE) standard for Energy Star qualification. In addition, HVI Loudness Testing and Rating Procedure standard provides a methodology for calculating a sone rating to meet this consistent and accurate testing goal. An excerpt that follow, taken from the HVI Loudness Testing and Rating Procedure standard summarizes the important goal of the standard.

"HVI Certification relies on ANSI consensus standards. HVI adds specific test procedures, designates a third-party laboratory, provides consistent calculations, oversees laboratory integrity, and certifies loudness ratings that recognize human psychoacoustic response.

Using those loudness ratings, HVI operates a comprehensive sound certification program that includes independent verification by HVI and the opportunity for competitors to challenge. The result is a full-featured loudness certification program.

Consistent ratings make it easy for designers and consumers to compare the loudness of HVI-Certified products and to be confident people will hear the products in the same relationship when installed. Because of its thoroughness and quality, HVI certification is recognized in codes and standards throughout North America, as well as most green-building programs."

The HVI standard continues to improve and provide consistent and accurate sound quality rating results. However, the rating offers only a single loudness assessment and ratings that are based on an analysis for a wide range of unit types. Using the testing standards imposed by HVI performance ratings, a new generic loudness assessment procedure has been formulated based on the results of the research performed herein. This newly recommended procedure can be used to evaluate the loudness contribution from various components of a kitchen range hood.

CHAPTER III

THEORY

The purpose of this section is to establish the underlying concepts needed to perform sound quality measurements. The physical concepts of sound power and sound pressure are established to gain insight on the importance of sound quality measurements. In addition the some calculation is introduced in order to measure the subjective sensation of human hearing.

Sound Pressure, Sound Power

Sound is interpreted in two physically ways. The first physical description for sound is sound power, which is the rate of acoustical energy given off by a sound source. Sound power is independent of the distance traveled and the surrounding environment. The decibel representation for sound power is shown in Equation 1.

$$L_w = 10 \log \left(\frac{W}{W_0} \right) \quad \text{Eq. 1}$$

where W_0 is the reference sound power equal to one picowatt 10^{-12} W (HVI 2009).

The second physical description for sound is sound pressure, which is a measure of the pressure variations caused by the sound waves. Sound pressure is dependent on the source's surrounding environment and distance from the source. Human ears detect pressure variations between 0.00002 Pa to 100,000 Pa; however since this is a large

range, the decibel representation for sound pressure is more commonly used and is shown in Equation 2.

$$L_p = 10 \log \left(\frac{P}{P_0} \right)^2 = 20 \log \left(\frac{P}{P_0} \right) \quad \text{Eq. 2}$$

where P_0 is the reference pressure equal to 20 μPa (ASHRAE 2005)

The relationship between sound power and sound pressure is dependent on the source's surrounding environment and distance from the source (Stevens, S.S. 1961). The relationship between sound pressure and sound power is shown in Equation 3 and Equation 4.

$$L_w = L_p - 10 \log \left(\frac{1}{4\pi r^2} \right) \quad \text{Eq. 3}$$

$$L_w = L_p - 10 \log \left(\frac{2}{4\pi r^2} \right) \quad \text{Eq. 4}$$

where r is the distance between the sound source and the point where sound pressure is measured.

Equation 3 is used when the source is present in a free field while Equation 4 is used when the source is centered on a surface so that the sound would radiate over half a sphere (ASHRAE 2005).

Sone Rating

The unit Sone is used for subjective loudness measurements while the unit phone is used for physical loudness measurements. Sone is an absolute term for loudness with a zero value at the threshold of hearing while phon is a unit of physical loudness that is referenced to as the sound pressure level at 1 KHz (noise measurements handbook). One sone is equal to the loudness of a 1 KHz tone with the sound pressure level of 40 dB or 40 phons. When comparing loudness measurements the unit sone is more widely used because it is linear to the human response of sound. A loudness of 2 sones is 10 dB higher than 1 sone and a loudness of 0.5 sones is 10 dB lower. Conversely, an increase to the sound pressure level by 10 dB corresponds to a doubling in loudness and a 10 dB decrease corresponds to the loudness being halved.

The sone value used to rate the loudness perceived by the human ear is based on the equal loudness index chart. This chart shows the loudness value given to each sound pressure level and 1/3 octave band frequency. Since a positive value is needed to show the magnitude of loudness, a threshold profile across the frequency spectrum for when the sound pressure is great enough for loudness to be perceived. The factor that will alter the equal loudness index profile for some contributing sound pressure readings is the semi-reverberant sound chamber's acoustic characteristics. As detailed in the sone calculation, the RCR is calculated based on the chamber profile from the RSS sound pressure measurements. The minimal sound pressure needed to correlate to a positive value or an audible loudness from the equal loudness index can be considered of as the threshold to human ear response. Figure 2 shows the zero sone threshold for sound

pressure needed to produce a greater than zero sone contribution for each frequency band in the semi-reverberant sound chamber.

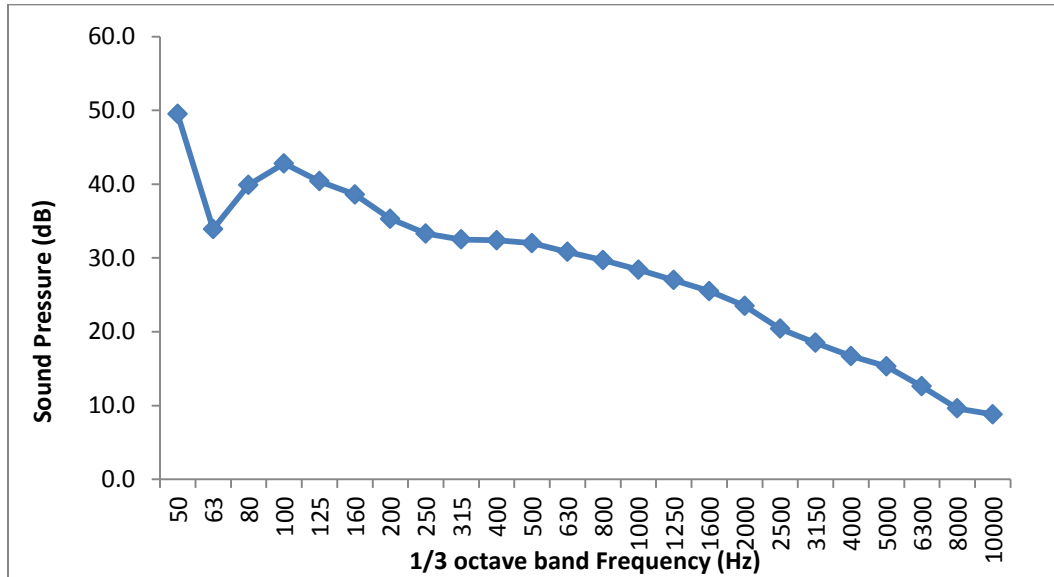

Figure 2: Zero Sone Threshold for the Semi-Reverberant Chamber

This profile represents the minimum sound pressure (dB) level needed for a measured device inside the semi-reverberant sound chamber to be considered audible and contribute to the total sone rating. The profile is different than the equal loudness index zero sone threshold since the reverberant-chamber alters the acoustical characteristics of the sound waves. Anything under the curve does not have sufficient loudness to add to the total sone rating.

The equal loudness index table indicates the values used in the sone rating calculation taken from ANSI S3.4 (HVI 2009). The table scales the loudness as a function of the sound pressure present and the frequency band. In general as the sound pressure increases, so does the loudness value. Using the equal loudness index table, a sone value can be calculated to represent the combination of perceived loudness across the tested frequency spectrum. Figures 3 and 4 show the entire index table.

Adapted for HVI Sep. '05. Notes below.		1/3 OCTAVE BAND CENTER FREQUENCIES IN HERTZ																											
Lookup ref. col no.		3	4	5	6	7	8	9	10	11	12	13	14	15	16	17	18	19	20	21	22	23	24	25	26	27			
dB-Hz	40	50	63	80	100	125	160	200	250	315	400	500	630	800	1000	1250	1600	2000	2500	3150	4000	5000	6300	8000	10000	12500	15000		
0																												0	
1																													1
2																													2
3																													3
4																													4
5																													5
6																												-0.02	6
7																												-0.02	7
8																												-0.02	8
9																												-0.02	9
10																												-0.02	10
11																												-0.02	11
12																												-0.02	12
13																												-0.02	13
14																												-0.02	14
15																												-0.02	15
16																												-0.02	16
17																												-0.02	17
18																												-0.02	18
19																												-0.02	19
20																												-0.03	20
21																												-0.03	21
22																												-0.03	22
23																												-0.03	23
24																												-0.03	24
25																												-0.03	25
26																												-0.03	26
27																												-0.03	27
28																												-0.03	28
29																												-0.03	29
30																												-0.03	30
31																												-0.03	31
32																												-0.03	32
33																												-0.03	33
34																												-0.03	34
35																												-0.03	35
36																												-0.03	36
37																												-0.03	37
38																												-0.03	38

Figure 3: Part 1 of the Equal Loudness Index Table (ANSI S3.4-1980)

39			0.02	0.12	0.21	0.31	0.43	0.55	0.63	0.86	1.02	1.10	1.18	1.27	1.35	1.44	1.54	1.64	1.75	1.87	1.99	2.11	2.24	2.38	2.18	1.70	39	
40		-0.03	0.07	0.16	0.26	0.37	0.49	0.62	0.77	0.94	1.10	1.18	1.27	1.35	1.44	1.54	1.64	1.75	1.87	1.99	2.11	2.24	2.38	2.53	2.32	1.82	40	
41		0.02	0.12	0.21	0.31	0.43	0.55	0.69	0.86	1.04	1.18	1.27	1.35	1.44	1.54	1.64	1.75	1.87	1.99	2.11	2.24	2.38	2.53	2.68	2.46	1.94	41	
42		-0.03	0.07	0.16	0.26	0.37	0.49	0.62	0.77	0.94	1.13	1.27	1.35	1.44	1.54	1.64	1.75	1.87	1.99	2.11	2.24	2.38	2.53	2.68	2.84	2.61	2.06	42
43		0.02	0.12	0.21	0.31	0.43	0.55	0.69	0.86	1.04	1.23	1.35	1.44	1.54	1.64	1.75	1.87	1.99	2.11	2.24	2.38	2.53	2.68	2.84	3.00	2.77	2.18	43
44		0.07	0.16	0.26	0.37	0.49	0.62	0.77	0.94	1.13	1.33	1.44	1.54	1.64	1.75	1.87	1.99	2.11	2.24	2.38	2.53	2.68	2.84	3.00	3.20	2.93	2.32	44
45		0.12	0.21	0.31	0.43	0.55	0.69	0.86	1.04	1.23	1.44	1.54	1.64	1.75	1.87	1.99	2.11	2.24	2.38	2.53	2.68	2.84	3.00	3.20	3.40	3.11	2.46	45
46		0.16	0.26	0.37	0.49	0.62	0.77	0.94	1.13	1.33	1.54	1.64	1.75	1.87	1.99	2.11	2.24	2.38	2.53	2.68	2.84	3.00	3.20	3.40	3.60	3.31	2.61	46
47		0.21	0.31	0.43	0.55	0.69	0.86	1.04	1.23	1.44	1.64	1.75	1.87	1.99	2.11	2.24	2.38	2.53	2.68	2.84	3.00	3.20	3.40	3.60	3.80	3.51	2.77	47
48		0.26	0.37	0.49	0.62	0.77	0.94	1.13	1.33	1.56	1.75	1.87	1.99	2.11	2.24	2.38	2.53	2.68	2.84	3.00	3.20	3.40	3.60	3.80	4.10	3.71	2.93	48
49		0.31	0.43	0.55	0.69	0.86	1.04	1.23	1.44	1.68	1.87	1.99	2.11	2.24	2.38	2.53	2.68	2.84	3.00	3.20	3.40	3.60	3.80	4.10	4.30	3.96	3.11	49
50		0.37	0.49	0.62	0.77	0.94	1.13	1.33	1.56	1.82	1.99	2.11	2.24	2.38	2.53	2.68	2.84	3.00	3.20	3.40	3.60	3.80	4.10	4.30	4.60	4.21	3.31	50
51		0.43	0.55	0.69	0.86	1.04	1.23	1.44	1.68	1.97	2.11	2.24	2.38	2.53	2.68	2.84	3.00	3.20	3.40	3.60	3.80	4.10	4.30	4.60	4.90	4.47	3.51	51
52		0.49	0.62	0.77	0.94	1.13	1.33	1.56	1.82	2.11	2.24	2.38	2.53	2.68	2.84	3.00	3.20	3.40	3.60	3.80	4.10	4.30	4.60	4.90	5.20	4.77	3.71	52
53		0.55	0.69	0.86	1.04	1.23	1.44	1.68	1.97	2.24	2.38	2.53	2.68	2.84	3.00	3.20	3.40	3.60	3.80	4.10	4.30	4.60	4.90	5.20	5.50	5.06	3.96	53
54		0.62	0.77	0.94	1.13	1.33	1.56	1.82	2.11	2.38	2.53	2.68	2.84	3.00	3.20	3.40	3.60	3.80	4.10	4.30	4.60	4.90	5.20	5.50	5.80	5.36	4.21	54
55		0.69	0.86	1.04	1.23	1.44	1.68	1.97	2.27	2.53	2.68	2.84	3.00	3.20	3.40	3.60	3.80	4.10	4.30	4.60	4.90	5.20	5.50	5.80	6.20	5.66	4.46	55
56		0.77	0.94	1.13	1.33	1.56	1.82	2.11	2.44	2.68	2.84	3.00	3.20	3.40	3.60	3.80	4.10	4.30	4.60	4.90	5.20	5.50	5.80	6.20	6.60	6.02	4.76	56
57		0.86	1.04	1.23	1.44	1.68	1.97	2.27	2.62	2.84	3.00	3.20	3.40	3.60	3.80	4.10	4.30	4.60	4.90	5.20	5.50	5.80	6.20	6.60	7.00	6.42	5.06	57
58		0.94	1.13	1.33	1.56	1.82	2.11	2.44	2.81	3.00	3.20	3.40	3.60	3.80	4.10	4.30	4.60	4.90	5.20	5.50	5.80	6.20	6.60	7.00	7.40	6.82	5.36	58
59		1.04	1.23	1.44	1.68	1.97	2.27	2.62	3.00	3.20	3.40	3.60	3.80	4.10	4.30	4.60	4.90	5.20	5.50	5.80	6.20	6.60	7.00	7.40	7.80	7.22	5.66	59
60		1.13	1.33	1.56	1.82	2.11	2.44	2.81	3.20	3.40	3.60	3.80	4.10	4.30	4.60	4.90	5.20	5.50	5.80	6.20	6.60	7.00	7.40	7.80	8.30	7.62	6.02	60
61		1.23	1.44	1.68	1.97	2.27	2.62	3.00	3.40	3.60	3.80	4.10	4.30	4.60	4.90	5.20	5.50	5.80	6.20	6.60	7.00	7.40	7.80	8.30	8.80	8.07	6.42	61
62		1.33	1.56	1.82	2.11	2.44	2.81	3.24	3.60	3.80	4.10	4.30	4.60	4.90	5.20	5.50	5.80	6.20	6.60	7.00	7.40	7.80	8.30	8.80	9.30	8.57	6.82	62
63		1.44	1.68	1.97	2.27	2.62	3.00	3.48	3.80	4.10	4.30	4.60	4.90	5.20	5.50	5.80	6.20	6.60	7.00	7.40	7.80	8.30	8.80	9.30	9.90	9.07	7.22	63
64		1.56	1.82	2.11	2.44	2.81	3.24	3.72	4.10	4.30	4.60	4.90	5.20	5.50	5.80	6.20	6.60	7.00	7.40	7.80	8.30	8.80	9.30	9.90	10.50	9.63	7.62	64
65		1.68	1.97	2.27	2.62	3.00	3.48	4.04	4.30	4.60	4.90	5.20	5.50	5.80	6.20	6.60	7.00	7.40	7.80	8.30	8.80	9.30	9.90	10.50	11.10	10.20	8.07	65
66		1.82	2.11	2.44	2.81	3.24	3.72	4.30	4.60	4.90	5.20	5.50	5.80	6.20	6.60	7.00	7.40	7.80	8.30	8.80	9.30	9.90	10.50	11.10	11.80	10.80	8.57	66
67		1.97	2.27	2.62	3.00	3.48	4.04	4.60	4.90	5.20	5.50	5.80	6.20	6.60	7.00	7.40	7.80	8.30	8.80	9.30	9.90	10.50	11.10	11.80	12.60	11.50	9.07	67
68		2.11	2.44	2.81	3.24	3.72	4.30	4.90	5.20	5.50	5.80	6.20	6.60	7.00	7.40	7.80	8.30	8.80	9.30	9.90	10.50	11.10	11.80	12.60	13.50	12.20	9.63	68
69		2.27	2.62	3.00	3.48	4.04	4.66	5.20	5.50	5.80	6.20	6.60	7.00	7.40	7.80	8.30	8.80	9.30	9.90	10.50	11.10	11.80	12.60	13.50	14.40	13.10	10.20	69
70		2.44	2.81	3.24	3.72	4.30	5.02	5.50	5.80	6.20	6.60	7.00	7.40	7.80	8.30	8.80	9.30	9.90	10.50	11.10	11.80	12.60	13.50	14.40	15.30	14.00	10.80	70
71		2.62	3.00	3.48	4.04	4.66	5.38	5.80	6.20	6.60	7.00	7.40	7.80	8.30	8.80	9.30	9.90	10.50	11.10	11.80	12.60	13.50	14.40	15.30	16.40	14.90	11.50	71
72		2.81	3.24	3.72	4.30	5.02	5.74	6.20	6.60	7.00	7.40	7.80	8.30	8.80	9.30	9.90	10.50	11.10	11.80	12.60	13.50	14.40	15.30	16.40	17.50	15.80	12.20	72
73		3.00	3.48	4.04	4.66	5.38	6.20	6.60	7.00	7.40	7.80	8.30	8.80	9.30	9.90	10.50	11.10	11.80	12.60	13.50	14.40	15.30	16.40	17.50	18.70	17.00	13.10	73
NOTES DESCRIBING HVI ADAPTATIONS SEPTEMBER 2005																												
1. Work done by Cori Zangl, Al Klug, and Dave Wolbrink.																												
2. Modified cells are italicized.																												
3. Table extended upward to 0 db; 10 db was top. 9 db @ 8kHz entered @ 10.																												
4. Anomalies corrected: 22db @ 630, 21db @ 800, 69db @ 8k, 49&52db @ 10k, 31&55db @ 12.5k.																												
5. Values extended upward in table to or past zero, using slope of previous 5 intervals.																												

Figure 4: Part 2 of the Equal Loudness Index Table (ANSI S3.4-1980)

The equal loudness index establishes a link between sound pressure measurements and perceived loudness sensations. Once all the equal loudness indices have been obtained, the sone rating is determined using the formula in Equation 5.

$$\text{Sone} = 0.85*[s_{\text{max}}] + 0.15*[\text{sum}(s)] \quad \text{Eq. 5}$$

Sone Calculation

The sone calculation used is in accordance with the one established by HVI loudness testing and rating procedure. The HVI sone calculation is based on the sound

pressure readings obtained from the sound test procedure and the sound power given for the RSS. The sone rating of the range hood characterizes the noise produced under conditions expected in its normal application. The calculation steps are explained in full detail below to provide a better understanding of the sone value.

Once all four sound measurements are recorded and the sound quality test is complete, the sone calculation can be determined. The background measurements are first logarithmically subtracted from the fan and RSS measurements as shown in Equation 6 and Equation 7.

$$L_{p, fan} = [Fan + BKG] - [BKG] = 10 \log \left(10^{L_{p, fan+BKG}/10} - 10^{L_{p, BKG}/10} \right) \quad \text{Eq. 6}$$

$$L_{p, RSS} = [RSS + BKG] - [BKG] = 10 \log \left(10^{L_{p, RSS+BKG}/10} - 10^{L_{p, BKG}/10} \right) \quad \text{Eq. 7}$$

The RSS sound power is measured and determined by a third party company in their laboratory. The sound power values provided by the third party company are considered the calibrated sound power values for the RSS and constant.

$$L_{w, rss} = \text{RSS Calibration Data} \quad \text{Eq. 8}$$

Since the sound power is known for the RSS, the RSS sound pressure measurements can be compared to give the acoustic characteristic for the semi-reverberant sound chamber.

The room behavior is found from the room characteristic ratio (RCR) which

arithmetically subtracts the measured RSS sound pressure from the calibrated RSS sound power.

$$\text{RCR} = L_{w,\text{rss}} - L_{p,\text{rss}} \quad \text{Eq. 9}$$

The RCR can then be applied to a fan and used to calculate the fan power from just the sound pressure measurement. The RCR is added arithmetically to the measured fan sound pressure which will convert the fan sound pressure recording to fan sound power.

$$L_{w,\text{fan}} = L_{p,\text{fan}} + \text{RCR} \quad \text{Eq. 10}$$

Once the fan sound power is determined, the sound pressure is determined based on the HVI setup conditions. The standard assumes the fan is 5 ft. from the center of the six microphone array and considers the acoustic field behavior as a spherical free field inside the chamber. The adjusted fan sound pressure is the fan sound power minus a constant, 14.65.

$$L'_{p,\text{fan}} = L_{w,\text{fan}} - 14.65 \quad \text{Eq. 11}$$

where 14.65 can be determined using the distance term in Equation 3.

$$10\log\left(\frac{1}{4\pi r^2}\right) = 10\log\left(\frac{1}{4\pi (5\text{ft.})^2}\right) = -14.65$$

(The 5 ft. was converted to meters for the calculation since the result is Pascals.)

The adjusted fan sound pressure represents what the sound pressure recording would be if the microphones were in the ventilating product's normal operating location. Since sound pressure decreases as it travels through a medium, the microphones will read a lower sound pressure than the sound pressure exerted around the ventilating product; the sound pressure must be back calculated from the formula for the sound power and sound pressure relation in a free field. The adjusted fan sound pressure recording is then used to find the equal loudness index for each band. Once all the equal loudness indices have been obtained, the sone rating is determined using the formula in Equation 5 above.

CHAPTER IV

EXPERIMENTAL APPARATUS

The test set-up includes a semi-reverberant chamber with a six microphone array that conforms to ANSI standard S12.51 (Determination of sound power levels) and AMCA standard 300 (Reverberant Room method for sound testing). The purpose of this section is to describe sound field measurements, the semi-reverberant room setup and the equipment used for loudness measurements. Measurements are conducted in a laboratory grade diffuse reverberant chamber. The setup and instrumentation are intended for laboratory testing and not field testing. The range hoods are tested in 24 one-third octave bands with center frequencies from 50 to 10,000 Hertz.

Sound Field Measurements

Sound measurements are performed in different types of sound fields depending on the kind of measurement taking place. A sound field is an area where sound waves are allowed to propagate due to pressure variations (ANSI S3.4-1980). Typical sound fields include pressure, free or diffuse. In the pressure sound field, sound pressure has the same phase and magnitude at any position within the field. This type of sound field is used in microphone sensitivity calibration. Pressure fields are found in small cavities and enclosures which occur in couplers applied for calibration by the reciprocity technique. Pressure fields are small compared to wavelength.

A free sound field is where the effects of any boundaries are negligible over the frequency range of interest (ASHRAE 2005). Sound waves propagate freely and are

unimpeded by objects. Free fields are difficult to realize in practice, however they can be approximated in anechoic rooms, which utilize high sound absorbing materials to eliminate reflections, or outdoors far away from reflecting surfaces. Free fields occur when the sound pressure level and intensity level decreases by 6 dB each time the distance from the sound source is doubled. The 6 dB decrease occurs because the amplitude drops by half. ANSI standard S12.55 explains the relationship between sound pressure and sound power under free field conditions and can be used to calculate the sound power of the source.

A diffuse sound field, or random incidence field, is where sound waves are reflected off surfaces and objects and can arrive at any point simultaneously from all directions with equal probability and sound pressure level (ANSI S1.15-2005). This type of sound field can be approximated with a reverberant room. A reverberant room has highly reflective walls, that are non-parallel, and contains no sound absorbing materials. In a reverberant room moving closer or further away from the sound source does not give a significant change in sound pressure level. This provides controlled acoustic measurements as the sound source reaches steady state inside the room. Semi-reverberant chambers are a more practical in design due to resonances in the room and sound absorption in the air.

Semi-Reverberant Chamber Set-up

Figure 5 below shows a schematic of the semi-reverberant chamber and anechoic muffler located in the southwest corner of the Riverside Energy Efficiency Laboratory (REEL) at Texas A&M University. The chamber conforms to American national

standard (ANSI S12.51-2002) and the home ventilation standard (HVI) 915. The semi-reverberant sound chamber was built to isolate the sound energy present inside the chamber from the sound energy outside the chamber while still allowing air to flow through the chamber (ANSI S12.51-2002). The chamber is a self-enclosed room separated from any exterior wall of the REEL. The chamber is used to perform sound quality test on mechanical ventilation equipment. Two types of equipment are primarily tested that include bathroom/utility fans and kitchen range hoods.

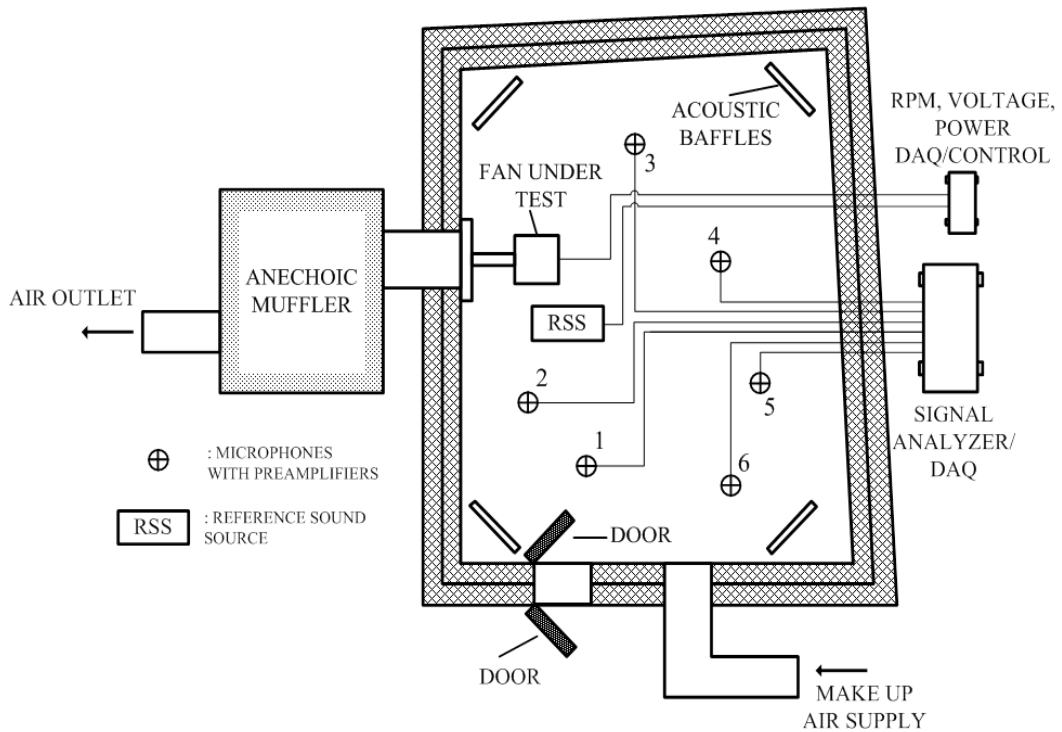

Figure 5: Schematic of Semi-Reverberant Testing Chamber Used at the REEL

The chamber is designed to reduce undesired noise transmission through the walls, ceiling, and floor. This is accomplished by using heavy duty, multi-layered insulating walls and vibration isolators. The exterior wall is constructed of concrete masonry bricks while the interior walls are constructed of sheetrock, plywood, 2x6 boards and Rockwool insulation. The room floor is raised off the laboratory floor and sits on top of vibration isolators that reduce low frequency sound waves as they travels through the ground. The chamber's interior dimensions are approximately 25 ft. x 20 ft. x 12 ft. with a volume of 6,000 cubic feet. The chamber is constructed out of a non-rectangular shape that eliminates parallel walls to obtain uniform reverberation characteristics. Figure 6 shows the six microphone array inside the sound chamber used to perform sound quality testing. Figure 7 shows the testing area for the range hood inside the sound chamber.



Figure 6: Sound Chamber Six Microphone Array



Figure 7: Sound Chamber Fan Mounting Area

The chamber has four airflow passages that are used to increase or decrease the static pressure across the fan. The openings consist of the inlet air supply duct, the outlet air duct, a walk-in door, and a pvc pipeline passage for the power and microphone cords. Make-up air is provided to the room by an assist blower through the inlet air supply duct when a unit under test has a high ventilation rate (usually over 250 cfm). The inlet air

duct has a sound muffler to reduce sound entering the semi-reverberant chamber and the assist blower is in a wooden box covered with acoustic sound absorbing foam. The outlet air duct runs through an anechoic muffler affixed to the side of the semi-reverberant chamber that prevents echoing sounds from the fan reflecting back into the semi-reverberant chamber as well as preventing any environmental sound entering through the air outlet duct. The anechoic muffler is connected to the test chamber by a rectangular isolation duct, and is approximately 8 feet per side. The muffler outlet discharges to atmosphere, avoiding entry to the reverberant room. The pvc pipeline passage is sealed on both ends with a high density putty to reduce sound wave transmission through the pipe. Dampers are used at both the inlet and outlet ducts in order to adjust static pressure and volumetric flow of a fan under test.

The interior of the semi-reverberant chamber consist of non-parallel highly reflective walls, four acoustics baffles, six microphones with preamplifiers, a reference sound source (RSS), the unit under test, and all microphone and power cords. The location of six random incident microphones with preamplifiers is determined by the multiple-microphone qualification process described in ANSI S12.51. The four acoustic baffles are used to minimize three dimensional standing waves and help create a diffuse field inside the chamber.

The floor, wall, and ceiling were constructed with different materials and each have a different total thickness. The materials listed in Table 1, Table 2 and Table 3 are represented in the order constructed from the chamber interior to the chamber exterior.

Table 1: Sound Chamber Floor Construction Materials

Location	Material	Thickness (inches)
Chamber Interior	Concrete	Not Available
	Sand	20
Chamber Exterior	Concrete	5

Table 2: Sound Chamber Walls Construction Materials

Location	Material	Thickness (inches)
Chamber Interior	Sheet Rock	0.625
	Plywood	0.5
	2" x 6" Construction	Not Available
	Plywood	0.75
	Rockwool Insulation	2.0
Chamber Exterior	Concrete	Not Available

Table 3: Sound Chamber Roof Construction Materials

Location	Material	Thickness (inches)
Chamber Interior	Sheet Rock	0.625
	Plywood	0.5
	2" x 8" Construction	Not Available
	Sheet Rock	0.5
Chamber Exterior	Lead	0.0625

Instrumentation

Sound quality ratings are achieved by measuring the sound pressure inside the semi-reverberant chamber with a the six microphone array, preamplifiers, microphone cables, RSS, Pulse lap shop, Pulse data analyzer, tachometer and multi meter. The hardware for recording the sound pressure is manufactured by Brüel & Kjær. Brüel & Kjær specializes in manufacturing hardware and software for sound and vibration testing applications and is an international company.

The six microphones, inside the semi-reverberant chamber, consist of a pressure sensing condenser microphone and a preamplifier. The pressure sensing condenser microphone contains a metal housing, an electrical insulator, a diaphragm and a back plate behind the diaphragm, see Figure 8. Pressure sensing condensers microphones are used because they detect what the human ear detects, namely pressure variations. The microphones have a wide frequency range, flat response frequency, low distortion and

long term stability. In addition they give a high quality and high performance that is necessary for sound quality ratings (ANSI S1.15-2005).

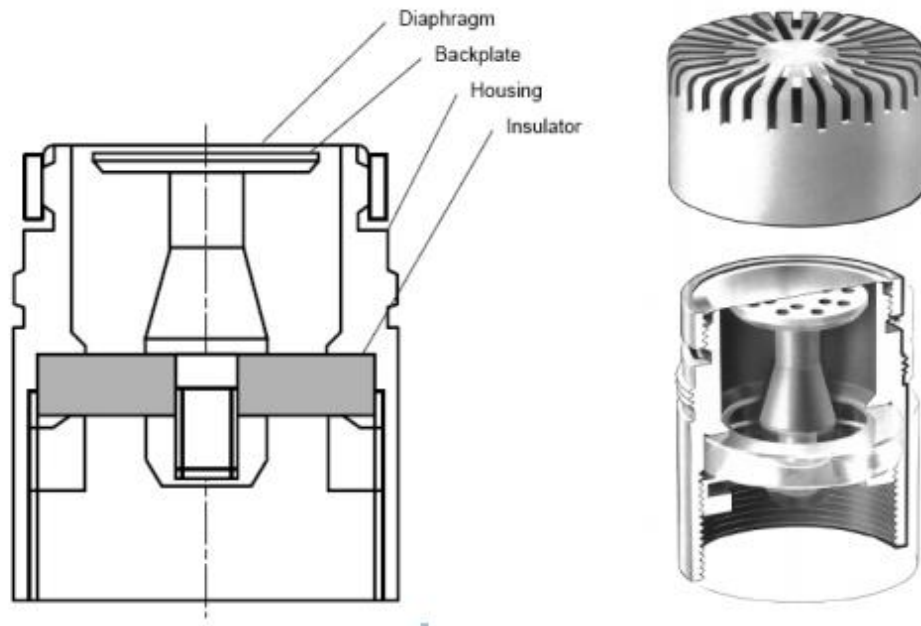

Figure 8: Condenser Microphone Design (Everest, A.F. 2001)

Pressure sensing measuring microphones use a constant electrical charge that is applied via the preamplifier for converting sound pressure to capacitance variations. The capacitor is formed by the two plates of the diaphragm and the back plate. The capacitance variations are converted into an electrical output voltage that is sent to the data analyzer. The capacitance variations are detected when an external pressure displaces the diaphragm of the microphone while the back plate remains stationary (ANSI S1.15-2005). The output voltage is proportion to the displacement of the

diaphragm. The output voltage signal is usually very low and must then be sent to the preamplifier in order to boost the low signal to reach the data analyzer. (ANSI S1.15-2005)

A preamplifier and microphone cable are attached to the pressure sensing condenser microphone in order to send the output signal to the data analyzer. The condenser microphone has high electrical impedance and it cannot overcome the load from the cable by itself. The preamplifier enables the microphone output signal to withstand the load and travel through long cables by minimizing the loading. The preamplifier minimizes the load because it has high input impedance, or low output resistance, that can withstand the loading from the cables. This insures that the signal is not distorted in any way when it reaches the data analyzer (ANSI S1.15-2005). The microphone cables run through the semi-reverberant sound chamber's wall and are individually attached to one of the six channel inputs of the PULSE data analyzer.

The Pulse Data signal analyzer interprets the output signal from all six microphone assemblies and converts it into the 24 ANSI-prescribed 1/3 octave bands, with center frequencies from 50 to 10,000 Hz. The 1/3 octave band uses constant percentage bandwidth (CPB) filters that are a percentage of the center frequency. The 1/3 octave band is represented on a logarithmic scale because the bandwidth of the lower frequencies is smaller than the higher frequencies. The signal analyzer performs real time Fast Fourier Transforms in order to transform the time domain sound pressure measurements into the 1/3 octave band frequency domain from 50 to 10,000 Hz. The PULSE data analyzer is connected directly to the designated sound station computer via

a cross over cable, in order to interpret the data. PULSE lab shop is used to display the microphone pressure readings on the sound station computer.

The PULSE data analyzer formats the data for PULSE lab shop. After the data is imported into the program, PULSE has several modules it can utilize to present the data. The version used on the sound testing computer is PULSE Labshop Version 11.1.0.58-2006-11-30 (PULSE 2006). The recorded decibel (dB) level for each frequency across the 1/3 octave spectrum is a 30 second average of each frequency band.

In addition to the data analyzer and Pulse software a RSS is used to measure the room characteristic ratio. The RSS produces steady broadband sound over the frequency range from 100 to 10,000 hertz. The sound from the RSS is uniform in all directions and leaves minimal sound shadows. The RSS consist of a squirrel cage impellor attached to a synchronous motor for consistent performance (HVI 915). REEL annually sends the hardware to West Caldwell Calibration Laboratories Inc. for calibration. The RSS's designated location is in the sound chamber as shown in Figure 5.

Calibration before each test is done to insure accurate pressure measurements. The calibrator used is a portable sound level acoustic calibrator used to individually calibrate each microphone. These calibrators provide a defined sound pressure level to which the microphone sensitivity can be adjusted. The calibrator fits flushed over the top of the microphone and emits 93.8 dB @ 1000 Hz for ½" microphones for 30 seconds (ANSI S1.15-2005).

The remaining equipment includes the tachometer and multi-meter. The tachometer is used to read the RPM of the unit under test. The tachometer wire is

relayed through the wall along with the microphone cords. The multi-meter is used to read the voltage sent to both the tested fan and the RSS. The multi-meter is International Organization for Standardization (ISO) certified. All the hardware used is summarized in Table 4.

Table 4: Instrumentation Used for Sound Quality Testing

Instrumentation	Manufacturer	Type/Model Number
Microphone	Brüel & Kjær	Type 4190
Preamplifier	Brüel & Kjær	Type 2669
PULSE signal Analyzer	Brüel & Kjær	Type 3560C
Sound Level Calibrator	Brüel & Kjær	Type 4230
Tachometer	Monarch	ACT – 3
Multimeter	Extech Instruments	EX470
Reference Sound Source	ILG Electric Ventilating Company	Model No. 17-05- 066A

Table 5 summarizes the corresponding uncertainties for equipment used during testing. All instruments are kept under certified ISO calibration so that the uncertainty of the resulting sound data can be analyzed.

Table 5: Sound Testing Equipment Uncertainty

Equipment Name	Description	Uncertainty
Microphones with preamplifiers	Sound pressure measurement in dB	0.35dB
Reference Sound Source (RSS)	Generating reference sound	0.54 dB
Signal analyzer and data acquisition device	Performing frequency domain analysis	0.10 dB
Multi meter	Measuring and monitoring voltage	0.068 V (up to 300V _{AC})
Tachometer	Measuring Fan RPM	0.50 RPM

CHAPTER V

EXPERIMENTAL TESTING PROCEDURE

The sound quality measurement process along with the new loudness assessment procedure is defined below. The results from the new loudness assessment have been used to form practical low-cost design modifications that can be easily implanted by manufactures to reduce noise. The general noise reduction procedure followed is also specified.

Sound Quality Measurement Process

All microphones are initially checked for calibration with the sound level calibrator before testing begins. The six internal microphones are calibrated to read 93.8 dB at 1000 Hz frequency. After calibration the fan is mounted inside the chamber and the RPM and static pressure are adjusted by using the throttling device connected to the make-up air supply. All fans are tested at 0.1 static pressure and the associated RPM is the initial set point for the fan. Once calibration and fan set-up is completed the sound measurement is performed.

A series of four consecutive sound pressure measurements are performed to evaluate the loudness of the ventilation range hoods. Each measurement sequence evaluates the sound pressure level, in dB, averaged over 30 seconds and taken in 24 one third octave bands with center frequencies from 50 to 10,000 Hz. The sound measurements taken include a fan measurement, a background measurement, a RSS

measurement, and a second background measurement in that order. All four measurements are taken in prompt succession to maintain background sound steadiness.

The first measurement sequence (FAN+BKG) is conducted with the test unit operating and the reference sound source turned off. The test unit operates at the nominal voltage (e.g. 35 W at 120V) and the RPM associated with a 0.10 static pressure. This data set represents the fan plus the background sound pressure measurement (L_{pfm}). After 30 seconds of averaging, the test unit is turned off and the next measurement sequence begins.

The second measurement sequence (BKG1) is performed with the fan and RSS both turned off with this measurement representing the background sound pressure measurement (L_{pbm}). The third measurement sequence (RSS+BKG) is performed with the RSS operating and the test unit turned off with this data set representing the sound pressure of the RSS (L_{prm}). The fourth measurement (BKG2) sequence is conducted with the test unit and RSS turned off with this data representing the second background sound pressure (L_{pbck}). After the above series of tests, the background steadiness is determined by comparing the two sets of background measurement data, BKG1 and BKG2, in one-third octave band frequency bands.

A test is considered a fail test if the second and fourth measurement sequences do not fall within the acceptable range for background steadiness. Failure is indicated by “NO TEST” on specific bands of the same report sheet or zeros in the Pass/Fail column of the test sheet. If a test is failed, each testing sequence is repeated. In addition, a test is a failure if the signal-to-noise ratio is over the acceptable limits for each frequency

range. For 50 Hz - 1250 Hz the SNR limit is 20 dB, for 1600 Hz – 5000 Hz the SNR limit is 10 dB, and finally for 6300 Hz – 10000 Hz the SNR limit is 3 dB.

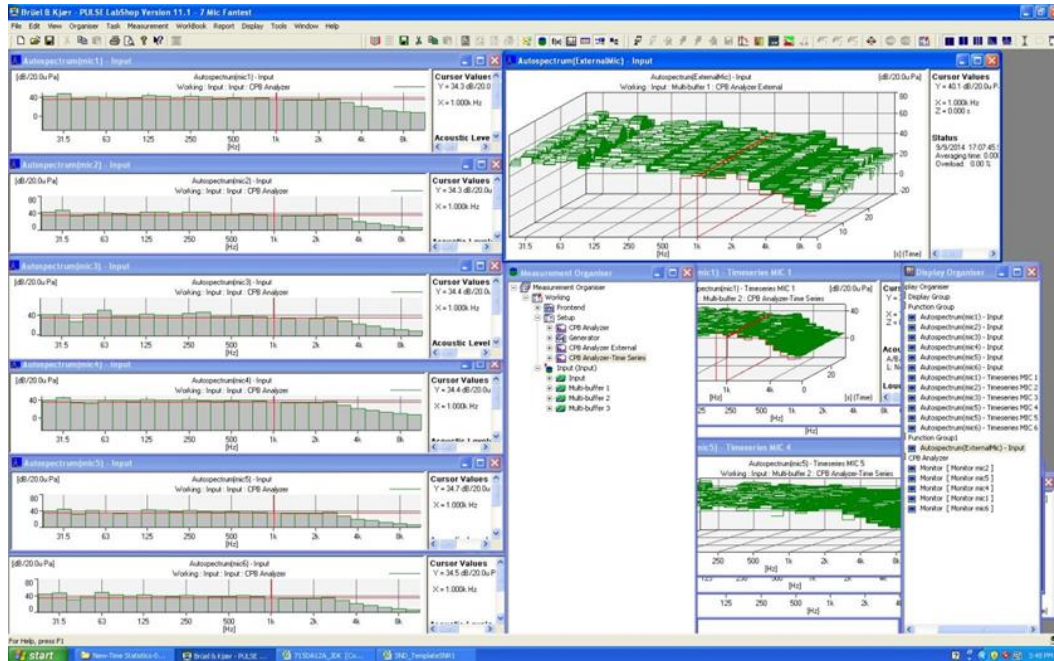

Figure 9: PULSE Labshop Software Interface

During each test sequence, PULSE LabShop and Microsoft Excel are processing the sound data. Figure 9 shows the PULSE software interface with the PULSE software file being the operating software for the Brüel & Kjaer sound analyzer. PULSE contains the six microphone array configured under a constant percentage bandwidth (CPB) analyzer. This file is set to measure the 24 1/3 octave bands from 50 - 10,000 Hz, and

once a test is ready, then PULSE is run. The averaged dB levels are displayed across the measured frequency spectrum for each microphone.

	A	B	C	D	E	F	G	H	I	J	K	L	M	N	O	P	Q	R
1	BAND	Tot	UNIT	BKG1	RSS	BKG2	BKGDiff	P/F		UNDER TEST	COMP	COMPDiff	P/F					
2	50	2.0	21.49	9.26	70.79	8.64	20.10	0		29.35	17.91	-11.45	0					
3	63	4.0	24.30	9.28	60.73	9.08	18.09	0		27.37	14.88	-12.49	0					
4	80	2.0	22.07	2.06	62.45	1.11	20.25	0		22.31	17.77	-4.54	0					
5	100	2.0	27.68	-0.43	67.19	-1.06	25.65	0		25.22	10.60	-14.63	0					
6	125	2.0	30.02	0.10	65.78	-0.21	23.84	0		23.94	3.94	-20.01	0					
7	160	1.0	33.37	-2.03	66.76	-2.44	30.70	0		28.67	-0.23	-28.90	0					
8	200	1.0	35.57	-2.19	65.84	-2.15	26.11	0		23.92	-1.59	-25.51	0					
9	250	1.0	35.21	-2.49	66.63	-2.56	26.42	0		23.93	-2.02	-25.95	0					
10	315	1.0	34.60	-2.08	68.40	-2.10	28.47	0		26.38	-1.58	-27.96	0					
11	400	1.0	33.67	-1.49	70.05	-1.50	24.94	0		23.45	-1.47	-24.93	0					
12	500	1.0	36.94	-1.45	72.02	-1.48	20.07	0		18.62	-1.00	-19.62	0					
13	630	1.0	37.51	-0.88	72.84	-0.86	16.81	0		15.93	-0.40	-16.33	0					
14	800	2.0	37.66	-0.10	73.54	-0.10	10.87	0		10.78	0.55	-10.23	0					
15	1000	0.5	34.57	0.90	73.85	0.91	8.88	0		9.78	0.96	-8.82	0					
16	1250	0.5	34.72	1.37	74.51	1.38	8.91	0		10.28	1.80	-8.48	0					
17	1600	0.5	29.61	2.21	73.44	2.25	4.16	0		6.37	2.56	-3.81	0					
18	2000	0.5	27.34	2.99	72.70	3.02	1.54	0		4.53	3.33	-1.20	0					
19	2500	0.5	23.14	3.75	70.50	3.75	0.73	0		4.48	4.11	-0.36	1					
20	3150	0.5	18.74	4.48	69.18	4.47	0.50	1		4.98	4.87	-0.11	1					
21	4000	0.5	15.14	5.06	67.62	5.06	0.88	0		5.94	5.51	-0.43	1					
22	5000	0.5	11.16	5.48	65.94	5.48	0.48	1		5.96	6.00	0.03	1					
23	6300	0.5	7.36	5.74	63.91	5.76	0.35	1		6.09	6.36	0.27	1					
24	8000	0.5	6.11	5.74	60.57	5.73	0.22	1		5.95	6.53	0.58	0					
25	10000	0.5	5.56	5.45	54.63	5.45	0.20	1		5.65	6.61	0.96	0					
26																		
27	SUM	623.54	50.72	1629.87	47.64	319.18				369.90	105.98	-263.92						
28	AVG	25.98	2.11	67.91	1.98	13.30				15.41	4.42	-11.00						
29																		

Figure 10: Microsoft Excel Database Storage

Figure 10 shows the Microsoft Excel file used as a database spreadsheet to store real time data from the data analyzer. PULSE is interfaced with Excel in order to import the sound pressure level for each microphone, and the Excel spreadsheet averages the six microphone array and displays a column of the averaged values on the main tab. Current test values appear under the column ‘UNDER TEST’, and the values are manually

passed into their respective test columns so that the same calculation process can be accomplished.

New Component Loudness Assessment Procedure

The general component assessment procedure designed for this investigation evaluates the loudness of mechanical kitchen range hoods based on an individual component assessment. The procedure has been developed in order to identify various components that can be modified to reduce the overall loudness of the range hood, which will help provide design recommendations that manufacturers can use in order to improve the sound quality in the indoor environment for consumers. This procedure can be used with current HVI testing standard 915 to provide an evaluation of the acoustic signature of the range hood based on the noise contribution from various components rather than a full assembly assessment.

The purpose of the loudness assessments in this study, for each set of range hoods, is to identify each component's contribution to the overall loudness. Dominant noise sources that exhibit the maximum sound pressure level (dB) will be determined, and the source's effect on the overall loudness will be assessed by comparing the loudness of each test set. The grille, damper, motor and enclosures are all components that may be tested depending on the configuration and removability.

Each test will start by determining the parts or components of the kitchen range hood that may induce vibration related noise or aerodynamic turbulent flow noise, such as the grille, damper, motor and enclosure. Only easily removable components of the range hood are considered. Once identified, all possible noise contributing parts will be

removed from the range hood and an initial loudness test will be completed according to the HVI 915 sound quality rating process. This initial loudness measurement will stand as the reference case that will be compared to the other test sets.

Sound quality tests will be performed with one of the removable parts (i.e. damper, grill, motor and enclosure) added to the reference assembly individually. For example, the grille might be added to the reference case and then a loudness test would be performed. This one step at a time procedure will assess each removable components effect on the loudness. It should be noted that each component may increase or decrease loudness depending on design characteristics. In the case of three or more removable parts, the loudness assessment will also include the testing of pairs of removable parts added at the same time to the reference case assembly. Because the measurement of loudness is non-linear testing two parts added simultaneously assess the compound effect on loudness.

Noise Attenuation Procedure

Practical low-cost structural design alterations and passive noise control techniques will be formulated, based on the results of component loudness assessment procedures performed herein, in order to reduce the overall loudness of the range hoods. For example, practical approaches such as an application of sound-proofing material or designing less restrictive grilles can lead to a quieter range hoods. These sound-reducing techniques could include alterations to the structural characteristics, absorption characteristics and aerodynamic characteristics of the range hood. The approach to

reducing the overall loudness consists of altering the range hood design and then re-testing of the range hood to evaluate the effectiveness of the alterations.

The primary goal of noise attenuation (or noise reduction) is to reduce the overall loudness to a comfortable level. A series of modifications will be applied to the range hood that will improve the structural design and acoustic absorption characteristics. The range hood will be sound quality tested individually after each modification is applied in order to investigate the impact to the overall loudness rating. A general description of the modifications to be investigated in the thesis include the addition/reduction of damping or stiffening materials, changing the design of sound radiating parts, and improving the construction or assembly of the range hood.

The main approach for noise attenuation will be through practical low-cost design modifications that may be easily integrated with current product design and are suitable for manufacture implantation. Various design modification will be formulated and tested for noise on an individual component basis and then assembly noise will be compared to the original full assembly test in order to evaluate the reduction in overall loudness.

The research project reported in this thesis has three phases to the noise attenuation procedure. The initial phase, after the range hood in its original condition is tested for noise, will consist of altering the acoustic absorption or structural vibration characteristics of the range hood. Longitudinal vibrations and bending moments within the various components of the range hood will be minimized in phase 1. The second phase of noise attenuation testing will focus on the aerodynamic characteristics of the

range hood at the air inlet and outlet. Air flow path restrictions can induce vortices due to flow reversal and downstream wakes creating high frequency noise. In addition viscous boundary layers may reduce wave speed creating less flow induced noise. The final phase of the noise attenuation process will combine various techniques utilized in the first two phases and assess the compound effect on loudness.

CHAPTER VI

RESULTS AND DISCUSSION

The new component loudness assessment procedure, introduced and used in this research, provides a better understanding into the overall loudness of kitchen range hoods by providing an individual component assessment. Previously, range hood assessments investigated only fully designed assemblies provided by manufactures. The results of the study reported herein show that modifications to the various components can either increase or decrease the loudness depending on the characteristics of the assembly and the modifications. It was found in this study that improvements to components of the range hood are possible and desirable to optimize noise reduction. Specifically, the noise attenuation results show that low cost alterations in structural and aerodynamic design can significantly reduce the overall loudness of the range hood; however tradeoffs occur with the appearance of non-linear results.

Loudness Assessment

Sound quality testing of four kitchen range hoods' representing a range of design configurations was performed by using the new loudness assessment procedure developed herein. The range hoods tested represent commercially available products that are commonly used in residential and commercial kitchens today. Two basic range hood designs that include either axial-flow fans or centrifugal-flow fans as the primary air moving device were included in this study.

Centrifugal-flow fans are the most widely used type of fan in kitchen range hoods. These fans are used in both commercial and high-end residential kitchens due to the higher amount of ventilation needed in these spaces. This type of fan uses a squirrel cage impeller wheel with forward or backward curved blades to move air. The air is drawn in through one or both sides of the impeller and is discharged at a right angle through the damper. In addition to centrifugal fans, kitchen range hoods can also include axial-flow fans as the primary air moving device. Axial-flow fans are more frequently used in residential kitchens due to their inefficiencies at high speeds and high flow rates. Axial fans use a propeller type blade that passes air straight through in the axial direction to the damper. The kitchen range hoods tested include two centrifugal-flow fans and two axial-flow fans for ventilation. Each range hood has a different damper design, grille design, and enclosure design.

In addition to fan differences, the range hoods tested also included basic component design differences in the damper, grille, and enclosure. These components all have a significant role in the overall loudness of the range hood due to vibrations induced in the damper and air flow restrictions from the grille. Two common damper designs found in commercial range hoods include a circular butterfly-type discharge or a rectangular discharge. Common types of grille design include either a single grille or dual grille cover system that protects the fan from grease damage and possible fire damage. Enclosure designs are frequently rectangular in shape, with variations in height being influenced by the size of the fan used for ventilation. Therefore in this study, various dampers, grilles and enclosure designs were tested with the different size axial

and centrifugal fans to investigate their influence on the overall loudness of the range hood.

Axial Fans



Figure 11: Axial Fan Kitchen Range Hoods Used for Testing

Figure 11 shows the two axial-flow kitchen range hoods used for testing. The range hood on the left hand side is fan 10_AR12 and the range hood on the right hand side is fan 10_AC11. Fan 10_AC11 is a residential kitchen range hood whose characteristics include a 5-blade axial-flow fan that is 5 inches in diameter, a circular-damper discharge that is 7 inches in diameter, and finally a single grill cover system that measures 10.25 inches long by 8.75 inches wide. 10_AR12 is a residential kitchen range hood whose characteristics include a 5-blade axial-flow fan that is 10 inches in diameter, a rectangular-damper discharge that measures 3.25 inches wide by 10 inches long, and finally, a two screen grill cover with dimensions 14.5 long wide by 11.5 inches wide.

With this dual grill cover system, the total length of the grill is 29 inches. Both of the above range hoods have two speeds for both high and low settings. Table 6 summarizes the range hood specifications for each component of the axial fans tested.

Table 6: Axial Fan Range Hood Specifications

Component	Specification	
	10_AC11	10_AR12
Range hood assembly	residential	residential
Fan	5-blade axial-flow	5-blade axial-flow
Fan size	5 in diameter	10 in diameter
Damper	circular	rectangular
Damper size	7 in diameter	10 in x 3.25 in
Grille	one cover	dual cover
Grille size	10.25 in x 8.75 in	29 in x 11.5 in
Enclosure height	13.5 in	12 in

Table 7 and 8 summarize the loudness results for the axial-flow kitchen range hoods at both high and low speed respectively. The above two units were tested for sound in the original full assembly considerations and with modifications to the grille and dampers.

Table 7: Axial Flow Loudness Results at High Speed

Code	Description	Loudness (sone)	
		10_AC11	10_AR12
FA	Full assembly	8.38	5.30
WG	With grille	8.25	5.12
WD	With damper	8.55	5.11
NDG	No damper/No grille	8.49	4.98

It can be observed in table 7 that for both range hoods the addition of the damper (WD) caused an increase in the overall loudness from the reference case (NDG), which is represented by the unit without a damper or grille. This increase in loudness, from NDG values 8.49 and 4.98 to WD values of 8.55 and 5.11, indicates that the damper has negatively influenced the sound quality of the range hood, which is an indication of how possible noise reduction techniques may be implemented. With the addition of the grille (WG) both fans had a different response in overall loudness. For fan 10_AC11, the addition of the grille caused a decrease in the loudness from 8.49 to 8.25 for the case NDG, while the addition of the grille in fan 10_AR12 caused an increase in loudness from 4.98 to 5.12 for the case NDG.

For 10_AC11, the damper increases the loudness while the grille decreases the loudness causing the full assembly case (with a damper and grille) to be similar to the reference case (without a damper and grille). This results shows that the grille can be used effectively to reduce the overall loudness of the fan. For fan 10_AR12 both the damper and grille increased the overall loudness causing the full assembly case to be the

highest sone value. This result shows that opportunities exist for both the damper and grille to be modified to reduce the overall loudness.

Table 8: Axial Fan Loudness Results at Low Speed

Code	Description	Loudness (sone)	
		10_AC11	10_AR12
FA	Full assembly	2.33	1.97
WG	With grille	2.01	1.95
WD	With damper	2.01	1.86
NDG	No damper/No grille	1.82	1.87

For the low speed case of axial-fan testing, it can be seen from Table 8 that for both fans the addition of the damper caused an increase in overall loudness from 1.82 to 2.01 and from 1.87 to 1.86 in the 10_AC11 and 10_AC10 cases, respectively. It can also be seen that the addition of the grille caused an increase in sones from values of 1.82 to 1.87 to values of 2.01 and 1.95. The increase in noise from the addition of the damper and grille can be also seen in the full assembly case, which has the highest sone value of special importance, these results show that both the damper and grille should be modified for better sound quality indoors.

Centrifugal Fans

Figure 12 shows the two centrifugal-flow kitchen range hoods used for testing, with the range hood on the right hand side being fan 13_CR12 and the range hood on the left hand side being fan 13_CC22.

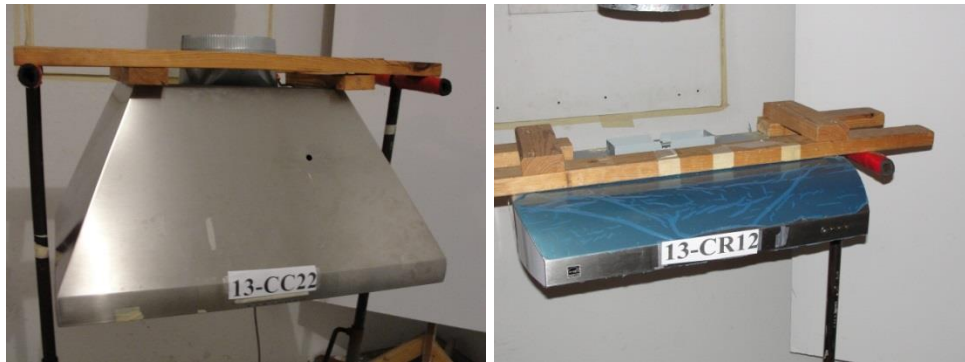

Figure 12: Centrifugal Fan Kitchen Range Hoods Used for Testing

Fan 13_CR12 is a residential range hood that includes a single centrifugal-flow fan, a rectangular damper discharge with dimensions 3.25 inches wide by 10 inches long and a dual grille cover system that measures 28.5 inches long by 12 inches wide. Fan 13_CC22 is a commercial range hood that includes a dual motor centrifugal-flow fan for a higher volume discharge of air. The range hood includes two squirrel-cage impellers, a 10 inch circular damper discharge, and a dual grille cover system that measures 12 inches wide by 28 inches long. Both fans also include high, mid, and low speed settings for ventilation. Table 9 summarizes the range hood specifications for each component of the centrifugal fans tested.

Table 9: Centrifugal Fan Range Hood Specifications

Component	Specification	
	13_CC22	13_CR12
Range hood assembly	commercial	residential
Fan	centrifugal-flow	centrifugal-flow
Fan size	dual motor	single motor
Damper	circular	rectangular
Damper size	10 in diameter	10 in x 3.25 in
Grille	dual	dual
Grille size	28 in x 12 in	28.5 in x 12 in
Enclosure height	28 in	15 in

Table 10 summarizes the noise results for the centrifugal fan testing at high speed. For 13_CR12, the addition of both the damper and grille reduced the overall loudness from the reference case (NDG), with decreases being from 7.84 to 7.12 for the damper and being from 7.84 to 7.23 for the grille. These effects can also be seen in the full assembly case as the overall loudness is less than case NDG, which is evidenced by the loudness changing from 7.84 to 7.42. This means that both the damper and grille can be used to effectively reduce the overall loudness of the range hood with proper design. For fan 13_CC22, the addition of the damper caused an increase in loudness from 10.73 to 11.47; furthermore the addition of the grille caused a decrease in overall loudness from the reference case NDG from 10.73 to 10.56, which is in contrast to the behavior of

the other units. This results shows that the damper is an area for sound quality improvement.

Table 10: Centrifugal Fan Loudness Results at High Speed

Code	Description	Loudness (sone)	
		13_CR12	13_CC22
FA	Full assembly	7.42	11.84
WG	With grille	7.23	10.56
WD	With damper	7.12	11.47
NDG	No damper/No grille	7.84	10.73

Table 11 summarizes the results for the centrifugal fan testing at the mid speed. For fan 13_CR12, both the addition of the damper and the addition of the grille increased the overall loudness of the fan from, 1.7 to 1.89 and 1.7 to 1.86, respectively for the reference case (NDG). These effects can also be seen in the full assembly case which has the highest sone value of 2.13. This means that the damper and the grille should be modified to reduce the overall loudness of the range hood. For fan 13_CC22, the addition of the damper increased the overall loudness from 6.7 to 7.3, while the grille decreased the loudness from 6.7 to 6.65. These offsetting effects can be seen in the full assembly case with both the damper and grille installed as the full assembly loudness is similar to the NDG case, which is without the damper and grille. This results shows that the damper and grille can be applied with minimal influence on the overall loudness.

Table 11: Centrifugal Fan Loudness Results at Mid Speed

Code	Description	Loudness(sones)	
		13_CR12	13_CC22
FA	Full assembly	2.13	6.75
WG	With grille	1.86	6.65
WD	With damper	1.89	7.30
NDG	No damper/No grille	1.70	6.70

Table 12 summarizes the results for the centrifugal fans testing at low speed. For both Fans, the addition of the damper increased the overall loudness from the reference case (NDG), while the addition of the grille caused a decrease in the loudness. This result shows that the grille can be used to effectively reduce the loudness of the range hood. In addition, because the damper is a cause of the noise, it should be improved in order to reduce the overall loudness of the full assembly.

Table 12: Centrifugal Fan Loudness Results at Low Speed

Code	Description	Loudness(sones)	
		13_CR12	13_CC22
FA	Full assembly	0.39	3.81
WG	With grille	0.16	3.62
WD	With damper	0.43	4.15
NDG	No damper/No grille	0.25	3.76

Table 13 summarizes the loudness change when adding the damper and grille. It can be seen that in 8 out of 10 cases the damper has caused an increase in the overall loudness of the range hood from the reference case (NDG). In addition, it can be observed that the addition of the grille has the opposite effect in that 6 out of 10 cases decreased the loudness. The largest increase was observed with the addition of the grille at low speed with a 70.27% increase, while the largest decrease occurred with the addition of the grille at low speed with a reduction of -35.38%.

Table 13: Component Effect on Overall Loudness for Each Range Hood

Unit	Speed	Effect on Loudness		Percent Change	
		Damper	Grille	Damper	Grille
10_AC11	Low	↑	↑	10.59	10.13
	high	↑	↓	0.74	-2.77
10_AR12	Low	↓	↑	-0.64	3.99
	High	↑	↑	2.72	2.93
13_CR12	Low	↑	↓	70.27	-35.38
	Mid	↑	↑	11.61	9.77
	High	↓	↓	-9.24	-7.77
13_CC22	Low	↑	↓	10.58	-3.54
	Mid	↑	↓	8.95	-0.78
	High	↑	↓	6.93	-1.60

These results show that the damper and grille both have an influence on the overall loudness of the range hood and may be modified to improve sound quality indoors. The following section further investigates and establishes techniques that may be used by manufacturers to reduce the damper and grille noise contributions and thus the overall noise and loudness of range hood fans.

Acoustic Loudness Signature

Fan 13_CC22 was selected for further testing in order to investigate practical low-cost noise attenuation techniques that were found based on the loudness assessment results. From the fans tested in this study, the centrifugal-flow dual motor commercial range hood experienced the highest loudness values across all speeds indicating the greatest need for improvement. Further acoustic analysis of fan 13_CC22 was completed to better understand the overall impact of the noise reduction techniques performed. It should be noted that all frequency response testing was completed herein only on the 13_CC22 range hood.

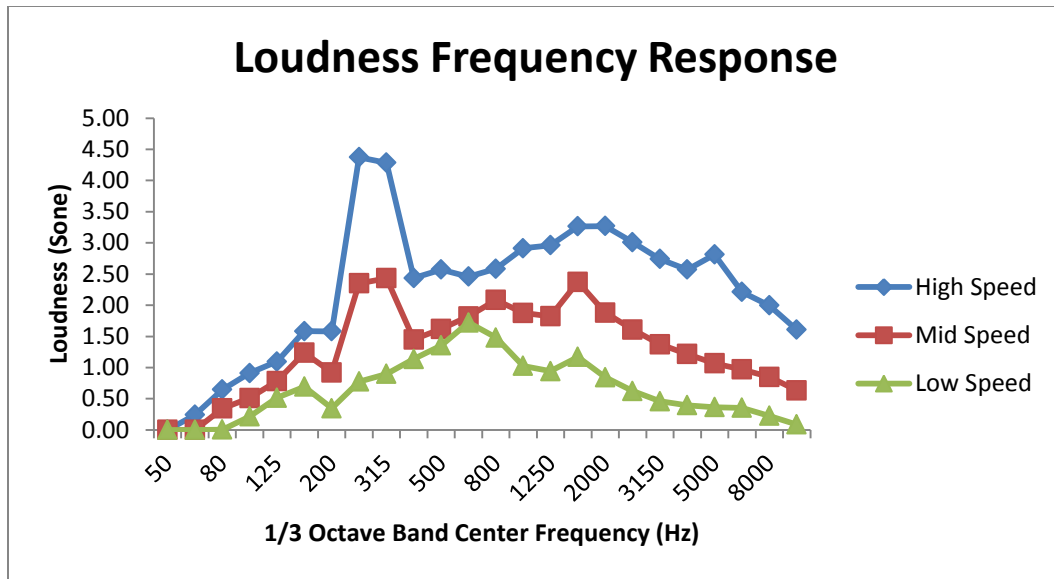

Figure 13: Loudness Frequency Response for Fan 13_CC22

Figure 13 shows the 1/3 octave-band loudness frequency response for fan 13_CC22. This figure represents the various center-band frequency contributions to the overall loudness of the range hood. In addition it shows the dominant frequencies associated with each speed. It can be observed that at high and mid speed the greatest impact to the overall loudness of the range hood occurred within the frequency range of 200 to 400 Hz. This frequency range is commonly associated with tonal noise driven by vibrations in components such as the damper, motor, enclosure, and grille (Grimm, N.R., and R.C. Rosaler. 1997). In addition, it can be seen there is a local maximum at 1600 Hz, which can be attributed to turbulent flow induced noise created by vortex shedding as air moves over the grille and through the fan blades (Grimm, N.R., and R.C. Rosaler. 1997). For the low speed setting the dominant frequency occurred at 630

Hz, this shift in frequency is caused by the addition of resonance frequencies created by motor inefficiencies that cause unbalanced rotary motion.

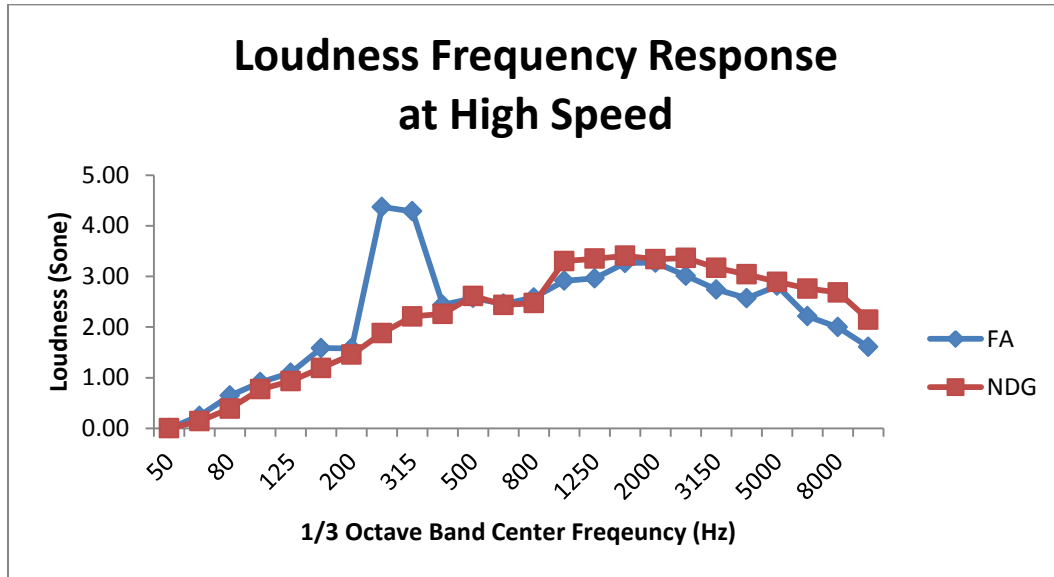

Figure 14: Fan 13_CC22 High Speed Response with Reference Case

Figure 14 shows the loudness frequency response at high speed for both the full assembly case (FA) and the reference case of no damper and no grille (NDG).

Comparing both loudness response curves, it can be observed that with the removal of the damper and the grille there is significant reduction in loudness for the dominant loudness frequencies between 200 Hz and 400 Hz. In addition, for frequencies below 1000 Hz there is a general decrease in loudness while at frequencies above 1000 Hz

there is a general increase in the overall loudness. Similar effects are also observed in the

loudness response curves at the mid and low speed fan settings shown in Figure 15 and Figure 16, respectively.

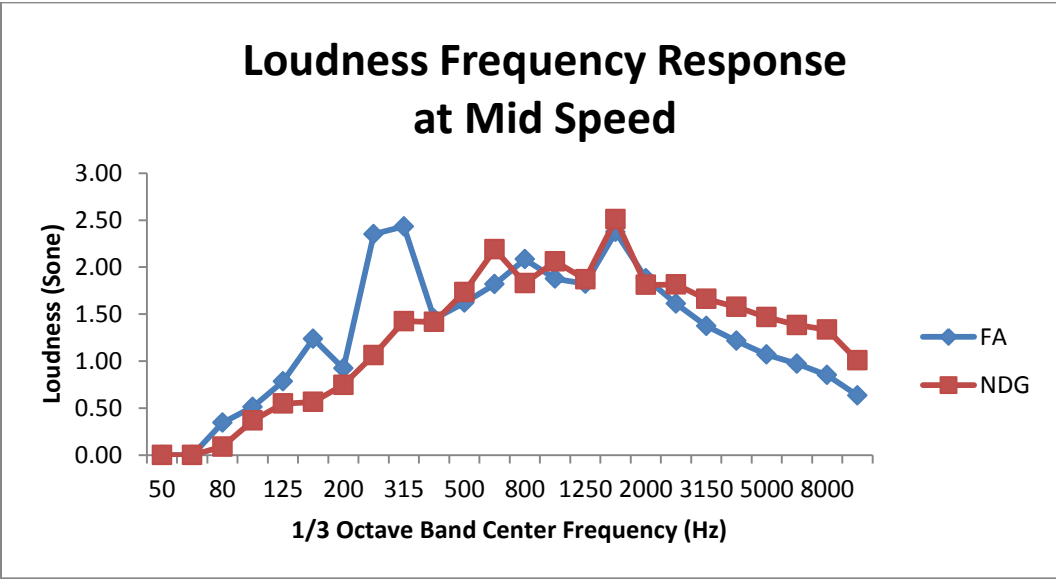

Figure 15: Fan 13_CC22 Mid Speed Response with Reference Case

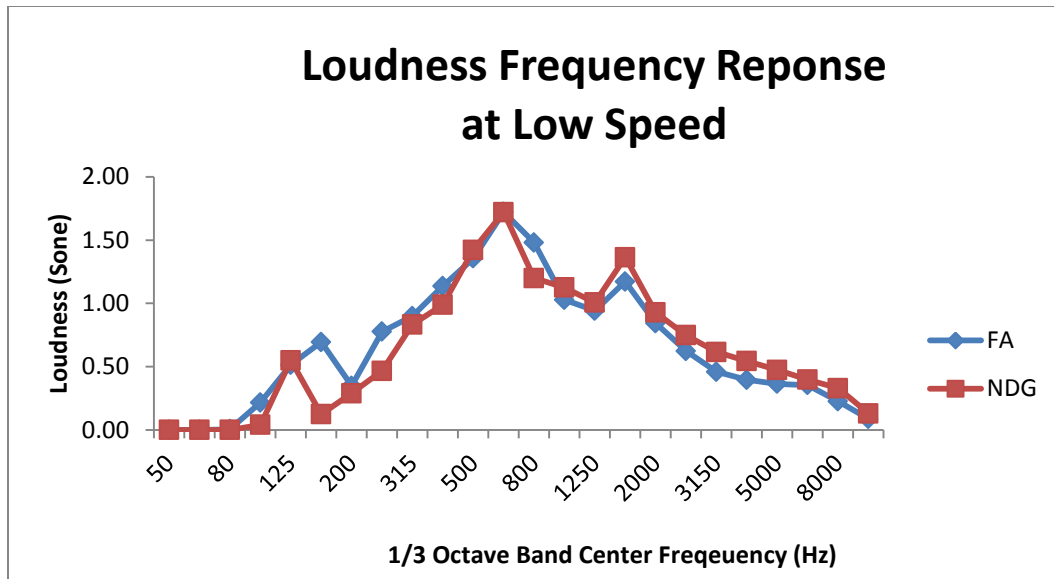

Figure 16: Fan 13_CC22 Low Speed Response with Reference Case

The loudness response for each speed in figures 14 through 16 indicates that with the removal of both the damper and grille that there is a reduction in low frequency vibrational noise. In addition, aerodynamic induced noise above 1000 Hz is maintained if not decreased for the full assembly case which has both the damper and grille installed.

Noise Attenuation

From the loudness assessment procedure, it has been observed that the contribution from the damper and grille can either increase or decrease the overall loudness depending on the various design characteristics. In addition, frequency analysis shows that with the removal of the grille and damper, for fan 13_CC22, there is a reduction in sone value for frequencies below 1000 Hz and an opposite increase in sone

value for frequencies above 1000 HZ. These results show that the vibration induced noise and flow (aerodynamic) induced noise caused by the damper design and grille design should be minimized in order to reduce the overall loudness. Therefore, modifications to fan 13_CC22 were implemented and tested in order to reduce the overall loudness of the range hood.

The main approach for noise attenuation will be through practical low-cost design modifications that might be suitable for manufacture product implementation. These modifications include alterations to the structural characteristics, absorption characteristics and aerodynamic characteristics of the range hood. All noise reduction techniques investigated herein were sound quality tested at high speed, mid speed and low speed according to the noise reduction procedure in Chapter 3.

Acoustic Absorption and Structural Vibration Noise Reduction Techniques

The initial sound-reduction phase in this study comprised of changing the acoustic absorption and structural vibration characteristics of the range hood. Practical design modifications to the enclosure, fan/motor assembly, baffle filter, and damper were implemented in order to reduce the overall loudness of fan 13_CC22. Table 14 provides a summary of the modifications investigated for noise attenuation during this study. In addition, the modifications are summarized below and photographs are shown in figures 17 through 21.

Table 14: Noise Attenuation Phase 1 Modifications

Code	Component Modified	Action Taken	Location	Figure
DMP	Damper	apply shock absorbing material	Metal components in mechanical contact	17
ENC	enclosure	apply acoustic rubber tape	inner surface of enclosure	18
MOT	Motor and enclosure	apply double vibration-isolation pad	between metal enclosure and motor	19
BAF	Grille	apply anechoic foam	inner surface of grille	20

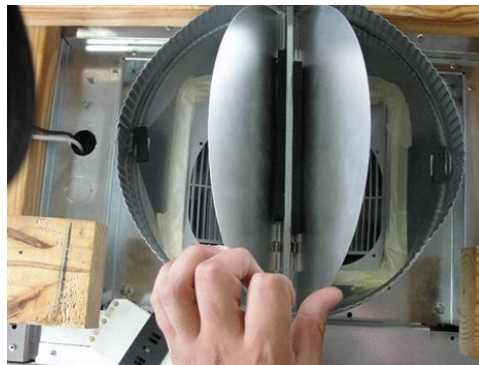

Figure 17: Damper Discharge Modification (Code: DMP)

Figure 17 shows design modification made to the damper discharge (modification code: DMP). In the loudness assessment procedure, a noticeable amount of noise was generated from the damper in all range hood designs. There are at least two major reasons for the damper noise, 1.) the vibrational noise associated with clapping of movable parts, and 2.) turbulent noise due to the change in cross-sectional area. Reducing the dynamic noise is treated in this study by applying shock absorbing material

to the metal components that experience mechanical contact during operation of the range hood.



Figure 18: Range Hood Enclosure Modification (Code: ENC)

Figure 18 shows a modification to the inner surface of the range hood enclosure (modification code: ENC). In this modification the inner surface is lined with an acoustic rubber tape that is made of a viscoelastic cellular-rubber material whose thickness is 1/8 in. This type of rubber pad is a porous material commonly used for noise reductions at high frequencies above 1,000 Hz. The material creates a viscous boundary layer that modifies the phase speed of the acoustic wave thus causing a reduction in momentum by molecular collisions at the wall creating a greater shear deformation in the bulk motion fluid (Grimm, N.R., and R.C. Rosaler. 1997), which allows for viscous losses to effectively convert acoustic energy into heat.

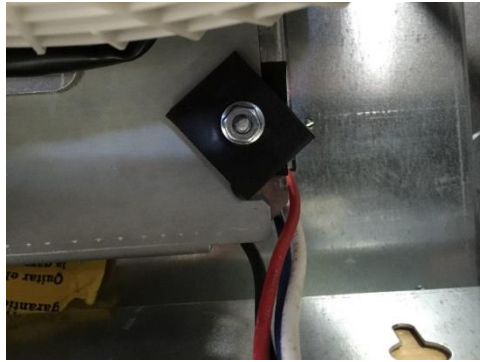

Figure 19: Vibration Isolation Pad between Motor and Enclosure (Code: MOT)

Figure 19 shows a double vibration-isolation pad that is inserted between the motor and enclosure connection to reduce contact roughness (modification code: MOT). Isolation pads are commonly used to help reduce vibration induced noise at low frequencies by minimizing internal contact resistance. The vibration force caused by the fan travels through the bolt and to the range hood enclosure causing additional vibrations in the damper and grille. The isolation pad diminishes the transmission of longitudinal vibrations that occur as a result of a load being applied to the bolt upon operation of the fan. The details of the double isolation pad are shown in the figure 20 schematic.

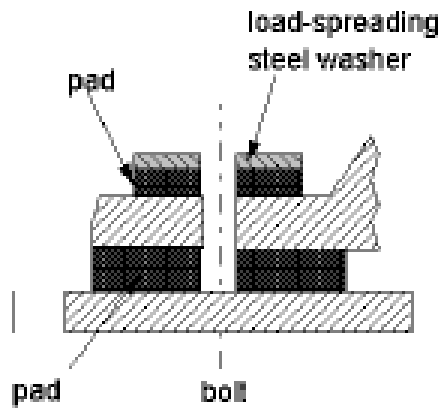

Figure 20: Double Vibration Isolation Pad Schematic (Everest, A.F. 2001)

The reason for adopting the figure 20 double-isolation pad instead of a single-isolation pad is that the use of a single pad between the fan/motor assembly and the enclosure results in a short circuit that would still provide a vibrational path from the fan to the enclosure via the top part of the bolt.



Figure 21: Grille Modification by Adding Anechoic Foam (Code: BAF)

Figure 21 shows a modification to the baffle filters achieved by adding the anechoic foam on the inward-facing surface of the baffle filter (modification code: BAF). In order to avoid an increase in airflow resistance, only the metallic part of the baffle filter is covered, which accounts for less than 70% of the total surface area. The anechoic foam is a porous material that enables viscous losses to convert acoustic energy into heat. The general concept of this modification is supported by the loudness assessment procedure, which showed that the reflection of the sound wave on the fan/motor-facing surface of the baffle filter had a significant influence on the overall loudness of the range hood. Noise test, were performed on the different modifications presented and described above with testing codes (DMP, BAF, MOT, ENC, and ENC-NBAF) and the results are summarized in Table 15

Table 15: Noise Attenuation Results from Phase 1

Code	Description	Loudness (Sone)			Loudness Reduction (Sone)		
		LS	MS	HS	LS	MS	HS
ORG	Original Setup (14-705, HPCB36NS)	3.8	6.8	11.8	N/A		
DMP	Damper with shock absorbing pad	3.63	6.03	10.28	0.17	0.77	1.52
ENC	Enclosure with acoustic rubber lining	4.08	6.65	11.12	-0.28	0.15	0.68
ENC-NBAF	Same to ENC, but w/o baffle filters	4.14	6.34	10.27	-0.34	0.46	1.53
MOT	Fan/Motor assembled with double vibration isolation	3.15	6.95	10.66	0.65	-0.15	1.14
BAF	Baffle filter partly covered by anechoic foam	3.66	5.71	10.11	0.14	1.09	1.69

In general the modifications to the absorption or structural characteristics resulted in a reduction to the overall loudness of the range hood. However for most modifications, the noise reduction is most noticeable at high and mid speeds, which can be attributed to the increase in air velocity and thus the development of turbulent flow at the higher speeds.

It can be seen from the above results that the two most effective solutions to reduce the range-hood loudness are modifications to the damper and the baffle filter, i.e. grille (DMP and BAF). After implementing the DMP modification, there was a significant reduction in the clapping sound radiating from the damper at all speeds. The damper modification is relevant to the current range hood setup and may be relatively easy to implement by manufacturers. Furthermore manufacturers could probably utilize any applicable material that results in the reduction of the metal-to-metal contact between the damper components as shown in Figure 17. When considering the amount of loudness reduction, the modification to the grille or baffle filter shown in Figure 21 is highly effective. However, an introduction of the anechoic material to the grille might not be practical due to grease damage and fire hazards. It should be noted that the grille modification only suggests the best potential to the loudness reduction. Therefore, similar characterizations of acoustic absorption and reflection for the grille component would require further investigation by manufacturers for practical uses.

Next to the baffle filter and damper modification, the implantation of double vibration isolation pads between the motor and enclosure is another practical option for the sound reduction. This technique had a higher noise reduction at the low speed

compared to any other case. This low speed reduction can probably be attributed to the fact that the structural vibration is more dominant than the airflow induced noise at low speeds. The MOT modification at mid speed shows an increase in loudness; however, this increase at mid speed can possibly be offset by combining this technique with other modifications.

The enclosure modifications (ENC) show some degree of sound reduction and could possibly be combined with other modifications for further improvement. For example, manufacturers should consider design improvements to the inner surfaces of the range hood enclosure, specifically near the motor/fan inlet. Another finding is that the enclosure space near the fan/motor inlet is restrictive, which can cause turbulent flow noise by creating a less fluidic diameter. There is noticeable loudness increases associated with this modification at low speeds.

While testing the ENC modification, there was a tonal noise radiating from the grille, which was amplified as the fan speed increased. Additional ENC testing without the baffle filter resulted in more noise reduction, with the reason being two fold; namely the grille guide contributes to structural vibrations because of metal-to-metal interference fits and because of the development of a standing wave inside of the grille due to the flow vector toward the fan inlet. A structural modification to the grille guide and its impact to the loudness reduction will be evaluated in the next stage.

Aerodynamic Noise Reduction Techniques

The next phase of the noise reduction process focused mainly on the aerodynamic characteristics of the range hood at the air inlet and outlet. In order to

modify the airflow paths of the range hood and to reduce flow induced noise, three different types of modifications were established. These modifications are: the introduction of an airflow guide in the damper discharge (modification code: EXG), the extension of the duct length between the fan outlet and the metallic damper (modification code: DDE), and the adjustment of the grille assembly (modification code: BAFA). Modifications DDE and EXG were implemented to treat flow-induced noise from the air outlet of the range hood by modifying the airflow path with a stream-line technique. The baffle-filter guide modification (BAFA) was implemented to modify the air inlet conditions of the range hood. Table 16 summarizes the modifications applied for noise attenuation in this study. Figure 22 through 24 show photographs of the aerodynamic modifications applied to the range-hood.

Table 16: Noise Attenuation Phase 2 Modifications

Code	Component Modified	Action Taken	Location	Figure
EXG	damper	apply streamline air-flow guide	between two air outlets of the fan discharge	22
DDE	damper length	apply duct extension	between fan outlet and metallic damper	23
BAFA	grille	lift grille to more horizontal position	grille guide	24



Figure 22: Airflow Guide Applied to Damper Outlet (Code: EXG)

Figure 22 shows the airflow guide applied to the damper outlet. Since this range hood uses a dual centrifugal fan system, it is difficult to run each fan at the same rotational speed and torque. Consequently, there is a significant probability of having different velocities from the fan-motor outlet. This velocity gradient can result in vortices, which could, in turn produce turbulent flow noise. Adjusting the fluid mixing point of the two different flow paths from each fan can impact the overall noise of the range hood (Grimm, N.R., and R.C. Rosaler. 1997). This modification introduces an airflow guide that works as a partition between the two outlets of the fan separating the different air flow paths and creating a mixing point further down the duct as the air exits the damper.



Figure 23: Duct Discharge Extension Modification (Code: DDE)

Figure 23 shows the duct extension installed between the fan outlet and the metallic, butterfly-type damper. The dimensions of the elongated duct are 9 in \times 9.5 in \times 17.25 in. The introduction of the elongated duct increased the distance between the fan outlet and the damper to 20 in, or twice the duct diameter. A potential exists to reduce the airflow-induced noise from the exhaust side of the range hood because of the turbulent or pulsating flow (tonal noise) in the duct. In addition, air settling will occur in the elongated duct so that fully developed flow characteristics can stabilize the airflow path from the fan outlet. A common practice to achieve adequate boundary layer growth resulting in fully developed flow is to increase the duct length by 2-4 duct diameters (Grimm, N.R., and R.C. Rosaler. 1997). This modification utilizes a duct extension twice the duct diameter (2D) in length, which in practice can reduce turbulence flow noise.



Figure 24: Grille Guide Adjustment (Code: BAFA)

Figure 24 shows the baffle filter adjustments made to reduce the overall loudness, which involved lifting the baffle filter to a more horizontal position instead of the inclined position currently set by the grille guides. In the previous phase of the sound reduction test, it was observed that there was a tonal noise developed by the baffle filter when assembled with the existing inclined baffle filter guide from this position; it can be assumed that there is an internal interaction between the baffle-filter guide and the baffle filter, which generates vibration induced noise. In addition, another test condition is considered by lifting the baffle filter one inch above the guide in order to assess whether additional ‘lift’ can reduce the loudness further. Table 17 summarizes the test results for all four aerodynamic modification presented in phase 2.

Table 17: Noise Attenuation Results Phase 2

Code	Description	Loudness (sone)			Loudness Reduction (sone)		
		LS	MS	HS	LS	MS	HS
ORG	Original Setup (14-705, HPCB36NS)	3.8	6.8	11.8	N/A		
EXG	Exhaust airflow guide to the damper	3.10	6.43	11.84	0.70	0.37	-0.04
DDE	Duct length extension to the damper	3.28	6.59	11.47	0.52	0.21	0.33
BAFA 1	Baffle filter sitting on the baffle filter guide	3.14	6.28	10.35	0.66	0.52	1.45
BAFA 2	Baffle filter lifted by 1 inch from the guide	3.51	6.57	10.79	0.29	0.23	1.01

In general, all four modifications listed in table 17 for phase 2 showed a reduction in loudness. With the exception of the low speed test, the largest loudness reduction achieved was through the BAFA1 modification at high and mid speed. This result is consistent with the observation developed in the phase 1 sound reduction study, which reported that the baffle filter causes a significant amount of noise due to its contact with the baffle-filter guide. Schematics of the baffle-filter guide modification BAFA1 and BAFA2 are depicted in Figure 25.

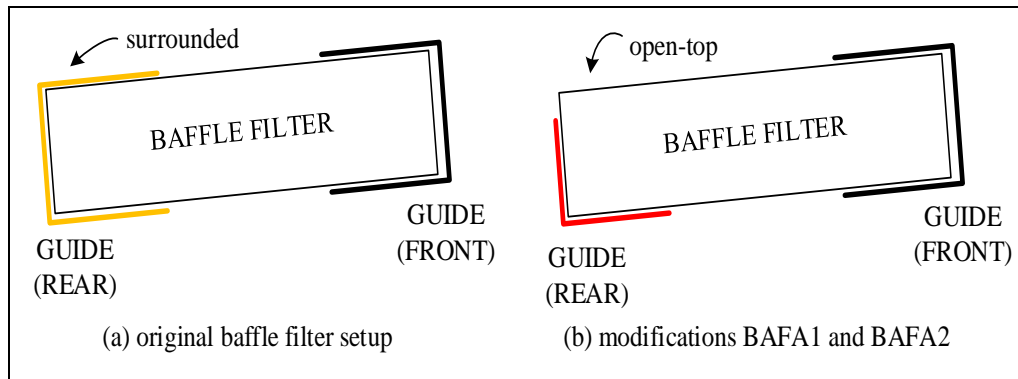

Figure 25: Baffle Filter Guide Schematic

Figure 25 (a) depicts the baffle filter surrounded by the baffle filter guide, Figure (b) depicts the baffle filter whose lower side is supported, but not surrounded, by the filter guide. The BAFA1 and BAFA2 modifications are similar to the set-up shown in Figure 25 (b). If the metallic-grille guide surrounds the baffle filter and the baffle filter does not make a tight contact fit to the range hood enclosure, then there can be possibility of vibrations developing between the points of contact, which can be seen in Figure 25 (a). Therefore, removing the excessive metallic contact between the baffle filter and the baffle filter guide, as shown in Figure 25 (b), can be a suitable option to reduce noise loudness. In addition, BAFA2 showed some loudness reductions; however, comparing this result to BAFA1 suggests that additional lifting of the baffle filter does not necessarily result in better sound quality.

For the low-speed test, there was a significant reduction in the loudness as a result of introducing the exhaust guide to the fan outlet. However, the loudness reduction at the high speed was not observed with this modification. Figure 26 reveals the loudness

response curve for each frequency for both high and low speed EXG modification testing.

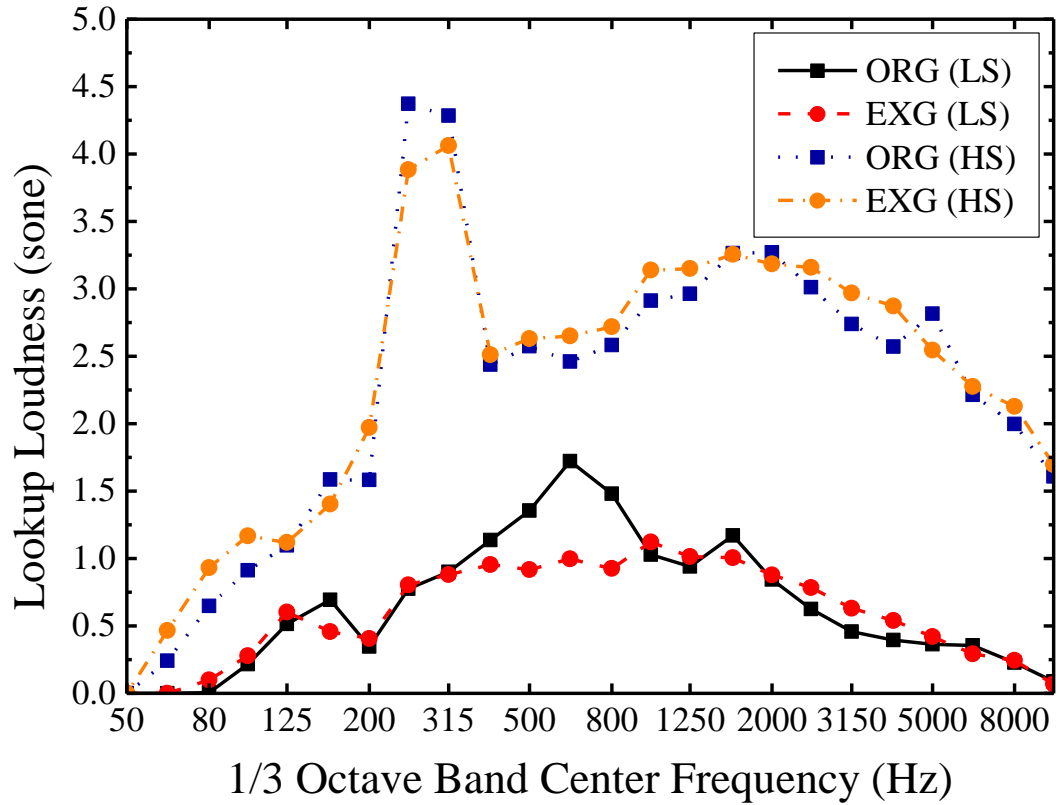

Figure 26: Loudness Frequency Response for Airflow Guide

As illustrated in Figure 26, the low-speed peak loudness at the mid-frequency bands (315 – 1,600 Hz) was suppressed after the introduction of the airflow guide; however, there was a noticeable increase in loudness in the high-frequency band (2,000

– 8,000 Hz). Also, the airflow guide did not enhance noise characteristics appreciably at the high speed.

The extended duct length modification between the fan outlet and the damper showed a reduction in the overall loudness at each speed. The amount of the loudness reduction is approximately 0.4 to 0.5 sone, which is slightly less than the ‘best’ results detected in the EXG modification at the low speed. However, the overall loudness reduction at all speeds (LS, MS, and HS) by the DDE modification suggests this type of modification can be suitable for range hood sound improvements.

Combined Sound Reduction Techniques

The last phase of loudness testing involved the application of multiple design modifications in order to evaluate the combination effects of various sound reduction techniques. The combination of noise reduction techniques can lead to a significant reduction in overall loudness for each speed. The range hood design was altered to include the DDE, BAFA, DMP and MOT modifications used in the previous noise reduction phase. When implemented individually each of these design variations has resulted in a reduction to the overall loudness at each speed. Figure 27 shows the test set-up for the combination test.



Figure 27: Noise Reduction Combination Test

Noise reduction techniques DDE and BAFA represent practical design approaches that may be implemented by manufacturers in order to alter the aerodynamic characteristics of the range hood and reduce high-frequency flow-induced noise. In addition each of these design approaches can be easily implemented by using a chimney design that elongates the damper outlet or a free suspension grille that creates less air flow restrictions for ventilation. Modification EXG was not used in this case because it interferes with the path to achieve fully developed flow created by the duct extension.

Design modifications DMP and MOT are implemented in the range hood design to reduce structural vibrations applied to the enclosure and damper during operation of the fan. Modification BAF was not chosen because of the limited practicality of the design, in that grease and other potentially flammable substances may get trapped within the porous acoustic material creating a fire hazard during high temperature cooking. Table 18 shows the sound quality test results for both the original test and the newly modified phase 3 combination test (Code: Mod Combo).

Table 18: Noise Attenuation Results Phase 3

Speed	Loudness (sone)		
	Original	Mod Combo	Reduction
High Speed (HS)	11.8	9.63	2.17
Mid Speed (MS)	6.8	5.91	0.89
Low Speed (LS)	3.8	2.86	0.94

In this case, the implantation of multiple noise reduction techniques leads to a significant reduction in overall loudness at all speeds. The largest loudness reduction occurred at the high-speed setting of the range hood with a reduction of 2.17 sones. In addition, when compared to any of the individually tested modifications from the previous phase, the noise reduction of the modified combination test achieved the largest noise reduction at both high and low speeds, namely 2.17 sones and 0.94 sones respectively. At mid speed there was less of a reduction in loudness, which can be attributed to the increase in noise from the MOT modification as seen in the phase 1 results.

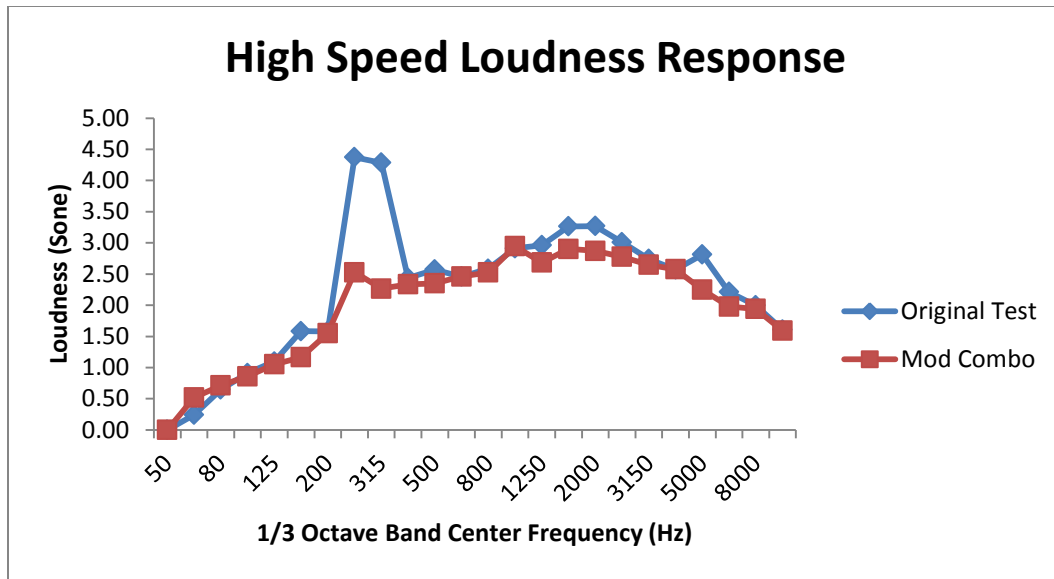

Figure 28: Loudness Reduction Response for Fan 13_CC22 at High Speed

Figure 28 shows the loudness response curve for both the original high-speed test and the modified combination high-speed (Mod Combo) test. In general, the loudness response curve for the MOD COMBO case shows a reduction in loudness at each frequency band. A significant reduction can be seen in the dominant frequency bands between 200 Hz to 400 Hz. This represents a reduction in vibration induced noise and tonal noise that is caused by operation of the fan. The Mod Combo shows that with the design modification implanted it is possible to produce a flat-response loudness curve, similar to the NDG response (No damper/No grille), which has fewer peaks from dominant noise radiation.

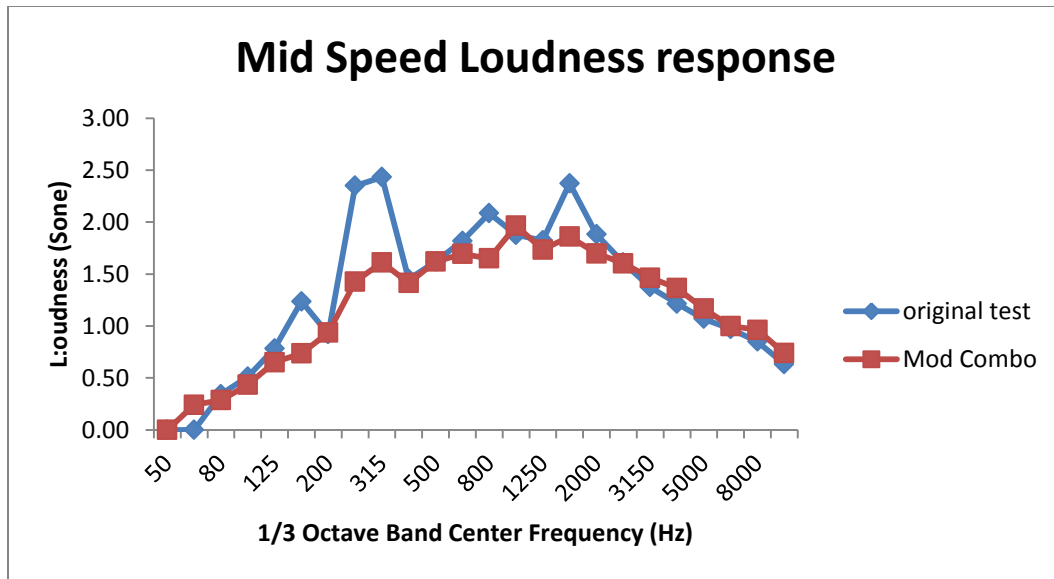

Figure 29: Loudness Reduction Response for Fan 13_CC22 at Mid Speed

Similar to the high speed response curve, Figure 29 shows the mid-speed response curves for both the initial test and modified combination test. The addition of the combined modifications at the same time provides a reduction in loudness across all frequency bands. The mid-speed response curve is not as flat of a response as the high-speed curve, which can be attributed to the tradeoff that was taken with the MOT design modification. As was shown in the structural noise-reduction phase (Phase 1), the MOT design caused an increase in overall loudness at mid speed. This can be seen in the loudness response curve with its local maximums that represent dominant frequency noise.

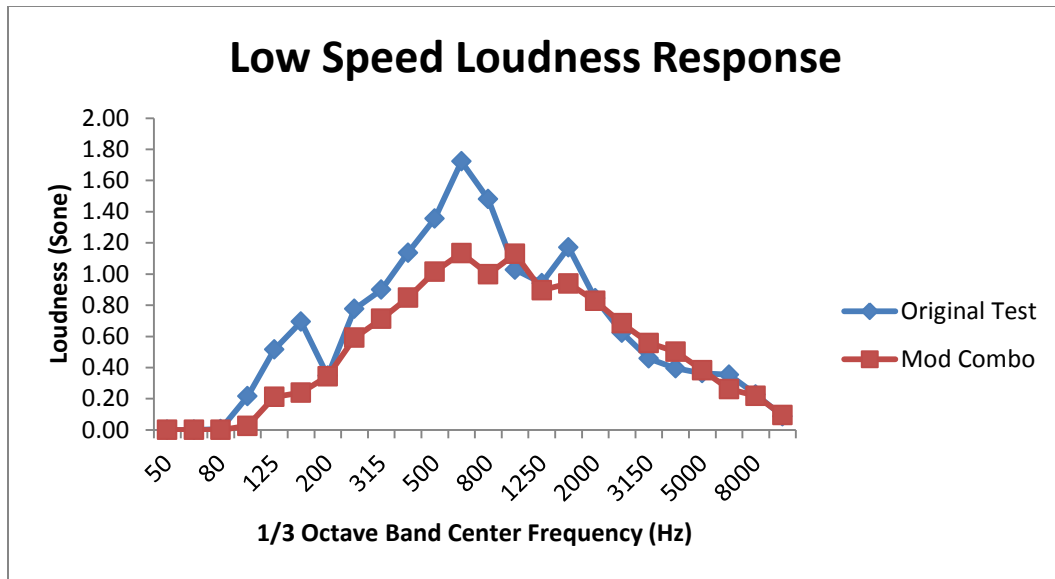

Figure 30: Loudness Reduction Response for Fan 13_CC22 at Low Speed

Figure 30 represents the low-speed sound quality test for both the original and modified range hood design. The dominant frequency at 630 Hz from the original test has been significantly reduced.

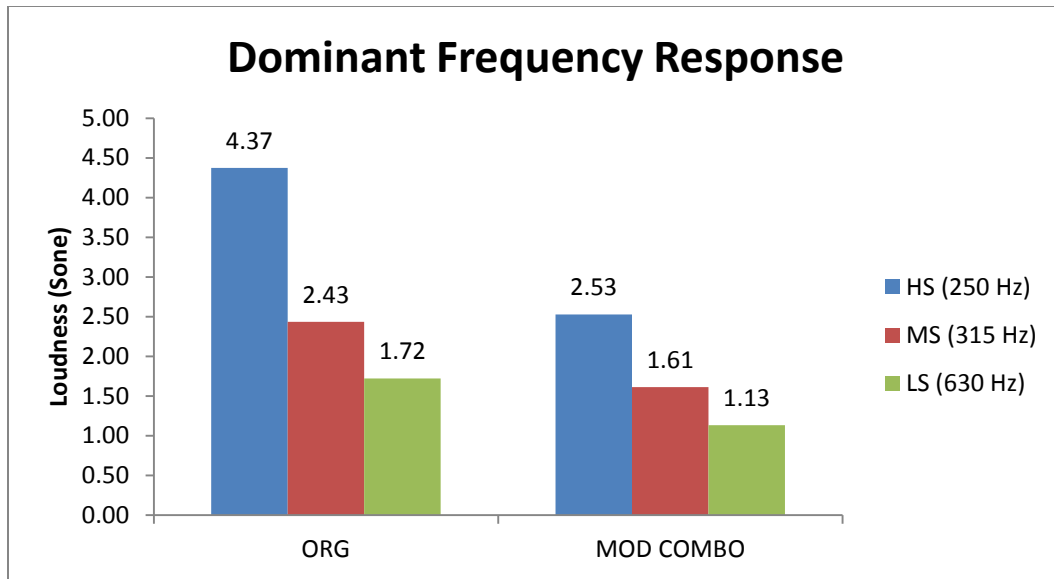

Figure 31: Dominant Frequency Reduction

In general, for all speeds the inclusion of the combined design modifications has significantly improved the overall loudness of the range hood. Figure 31 shows that for each speed the dominant frequency has been reduced. For example, at high speed the dominant frequency loudness of the full assembly test reduced from 4.37 sone to 2.53 sones. These design approaches are practical techniques that can be used by manufactures to improve sound quality indoors when designing sustainable green buildings. Noise from the fan can be reduced with low-cost design improvements that target structural vibrations and aerodynamic flow noise.

CHAPTER VII

CONCLUSION

From the loudness assessment procedure, it was concluded that the overall loudness of kitchen range hood is influenced mainly by the design of the damper and grille assembly. The results herein show that in 8 out of 10 cases the damper caused an increase in the overall loudness by 10% at high speed and as much as 70% at low speed. In addition, it has been observed that the grille caused a general decrease in loudness for 6 out of 10 cases. These results show that practical design improvements for both the damper and grille are needed to improve sound quality indoors.

The noise attenuation techniques implemented on the damper and grille resulted in a significant improvement to the loudness across each frequency. Using the techniques formulated, vibration and aerodynamic induced noise being reduced across all speeds of the range hood by as much as 15%. The greatest reduction in noise was observed at a high speed with a reduction of 2 sones, while mid and low speed experienced a reduction of 0.89 sones and 1 sone, respectively. These results show that improvement to the range hoods acoustic signature can be accomplished with low-cost design techniques if implemented properly.

When considering sound quality indoors for building occupants, the reduction of noise from mechanical ventilation can significantly improve overall indoor sound quality, which further improves health and comfort. Using the new component loudness assessment procedures and noise reduction techniques, developed and introduced in this study, we have created a better sound quality environment.

REFERENCES

- ANSI S12.51-2002. 2002. *Acoustics- Determination of Sound Power Levels of Noise Sources using Sound Pressure- Precision Method for Reverberant Rooms*. Melville: Acoustical Society of America.
- ANSI S1.15-2005. 2005. *Measurement Microphones - Part 2: Primary Method for Pressure Calibration of Laboratory Standard Microphones by the Reciprocity Technique*. Melville: Acoustical Society of America.
- ANSI S3.4-1980. 2003. *American National Standard: Procedure for the Computation of Loudness of Noise*. Melville: Acoustical Society of America.
- ASHRAE. 2005. *2005 ASHRAE Handbook: Fundamentals*. Atlanta: American Society of Heating, Refrigerating and Air-Conditioning Engineers, Inc.
- Crocker, M. 2007. Ratings and descriptors for the built acoustical environment. *Handbook of Noise and Vibration Control*. p. 1267. Hoboken: John Wiley & Sons, Inc.
- Everest, A.F. 2001. *Master Handbook of Acoustics Fifth Edition*. New York: McGraw-Hill.
- Grimm, N.R., and R.C. Rosaler. 1997. Noise control. *HVAC Systems and Components Handbook 2nd Edition*. p. 8.2.1 New York: McGraw-Hill.
- HVI. 2009. *HVI Loudness Testing and Rating Procedure*. Wauconda: Home Ventilating Institute.

Stevens, S.S. 1961. Procedure for Calculating Loudness: Mark VI. *The Journal of the Acoustical Society of America* 33(11):1577-1585.

Waye, K. P. and R. Rylander. 1997. *Effects on Performance and Work Quality due to Low Frequency Ventilation Noise*. *Journal of Sound and Vibration*, 205(4):467-474.