

MAKE YOUR

*Furniture*

LAST LONGER BY

*Reupholstering*

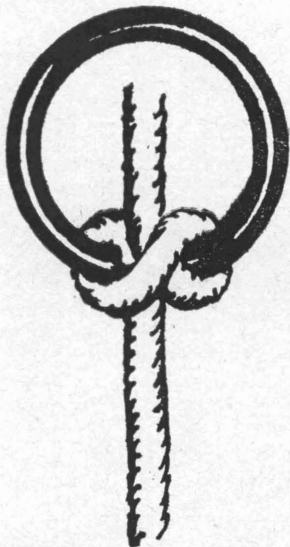

Issued By  
The Extension Service  
Agricultural and Mechanical College of Texas and  
The United States Department of Agriculture  
Ide P. Trotter, Director, College Station, Texas

#### ACKNOWLEDGMENTS

Be Your Own Upholsterer—Bulletin 648  
By Florence E. Wright, New York State College,  
Cornell University, Ithaca, N. Y.

Upholstered Furniture—C. W. Seager

Drawings-Upholstered Footstool—W. S. Allen,  
Texas Extension Service

# MAKE YOUR *Furniture* LAST LONGER BY *Reupholstering*

by  
Bernice Claytor  
Extension Specialist in Home Management  
Texas A. & M. College

Reupholstering is a method of making old chairs and couches more comfortable and attractive. It makes them last longer and helps to save money for other furniture or conveniences.

## PREPARING A PIECE OF FURNITURE

Certain things have to be done to prepare a piece of furniture for reupholstering. For an example, use a chair. First, take off the lining from the bottom and examine the webbing and springs. If the webbing is weak, broken, or pulled loose from the frame, or if the springs are out of shape or weak, remove all the old upholstery material and get it ready for new webbing and springs.

Remove every tack from the woodwork. When you remove old upholstery materials from a piece of furniture, observe every detail as to the methods used in the original work. This will give you much information for the reupholstering. Notice how the braid or gimp, the outer cover, the inner covering, padding, springs and webbing were put on. Give particular attention to sturdy construction. Examine the original finishing touches, such as the corners, how the cover fits around the legs and arms, how the braid is put around corners and other details. If they are well done, they will serve as guides in your work. If they do not appear satisfactory, try to improve on them.

Notice the size of tacks used for various purposes. Save old materials until you are sure just how they were used. Sometimes the best of these can be used again. Frequently some of the original work can be improved. The outer covering often may be used as a pattern in cutting the new cover. However, in using the old cover as a pattern, check first to be sure it still fits, as it may have stretched or torn. More padding may be needed and if this is true, the covering must be made larger. An additional inch or two allowed on all edges will be needed for pulling the material tightly, for tacking and for seams.

Any repairs needed to be done on the chair or couch frame should be done before upholstering is begun. Also if the the wood needs to be refinished, that should be done before upholstering. A good time to do this is after the old upholstering has been removed.

Furniture glue should be used for fastening broken or loose parts. A good liquid furniture glue is best. It is important to force the glue into the pores of the wood. To do this, scrape off all old glue or varnish, apply fresh glue to the parts and put them together under strong pressure overnight. A cabinet maker with clamps to hold pieces together can handle jobs too difficult to do at home. In many cases a rope tourniquet is helpful in holding glued parts together.

## TOOLS AND EQUIPMENT NEEDED

Tack hammer—magnetized if possible.

Scissors.

Needles:

*SMALL SACK NEEDLE* with large eye—  
3 inches to 4 inches long.

*FLOCKING NEEDLE* — single 3 square  
point, one eye, 6 inches long, 12 gauge.

*CURVED UPHOLSTERY NEEDLE* —  
round point, light weight, 3 inches  
long.

*CURVED UPHOLSTERY NEEDLE* —  
round point, 6 inches long.

Tape measure

Yard stick

Tacks:

No. 3 *SMALL SIZE*, for the muslin and  
outside covers.

No. 8 *MEDIUM SIZE*, for the webbing  
and spring cover.

No. 12—*LARGE SIZE*, for holding spring  
twine.

Gimp tacks or finishing tacks with large heads, about  $\frac{1}{4}$  inch size.

Upholsterer's skewers—1 dozen or more

Pencil

Pliers

Razor blade

Machine attachment for stitching cording—one one foot pressure foot

Ice pick or regulator—for adjusting and distributing padding under burlap

Pins

Webbing stretcher

First aid kit

The webbing stretcher can be made from a piece of wood  $\frac{3}{4}$ " x  $3\frac{1}{2}$ " x  $7\frac{1}{2}$ ". If the sides of the block are slightly curved in, it will be easier to grasp. Five or six 8-penny nails are driven into one end of the block; the heads are cut off and the ends of the nails filed to make sharp teeth about  $\frac{1}{2}$  inch

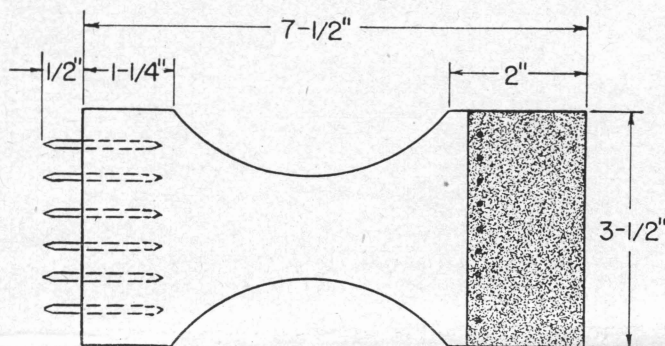

Webbing stretcher

long. The other end of the stretcher is covered with rough leather, felt, velvet or similar material to prevent the stretcher from slipping and marring the side of the frame, in case the wood is to be finished.

#### MATERIALS NEEDED

**WEBBING**—unless the springs are attached to a metal frame or wooden slats. The webbing should be of good quality, strong, closely woven material in order to support the weight put upon it. Some elasticity in webbing is also desirable. The durability of a piece of furniture depends largely upon the quality of webbing used to support the springs. A convenient width for webbing is about  $3\frac{1}{2}$  inches.

**SPRINGS**—double knotted seat springs are preferable—heights of 4 inches and 6 inches and wire of gauge 11 and 10 are often desirable sizes. The height of the springs should be twice the height of the framework of the seat.

In some cases the old springs in the chair can be used. If any are broken, weak or out of shape, replace them.

**ITALIAN FLAX SPRING TWINE NO. 60** for tying springs. This usually comes in one-pound balls. Spring twine receives the hardest wear of any material in a piece of upholstered furniture. It is subjected to strain and to rubbing against the wires every time the piece of furniture is used. For this reason, it is most important that the spring twine be very strong.

**ELM FLAX MATTRESS TWINE NO. 252**—strong, medium weight twine with a smooth hard finish—for sewing the springs to the webbing and stitching burlap to the springs. This is usually called tufting twine.

**COVERING FOR THE SPRINGS**—new, closely woven burlap is best—heavy strong sack material that is in good condition may be used. It should be strong enough that the springs will not cut through the material.

**COARSE PADDING**—Curled horsehair is best for the first layer but it is expensive and scarce. Often curled hair may be obtained from old automobile seats, furniture or discarded hair mattresses. If the hair is quite dusty and dirty, it should be packed very loosely in a light weight muslin bag and cleaned with a vacuum cleaner. The dust may be removed by beating the bag with a stick.

Moss is the next best material.

Palm fiber and sisal are frequently used for coarse paddings.

Excelsior is not recommended for padding as it mats within a short time.

Tow is the least desirable of commonly used materials.

One may use the padding that was formerly in the chair if it is clean and in good condition.

**UPHOLSTERER'S COTTON FELT**—of good quality is needed for the second layer of padding.

**HEAVY UNBLEACHED MUSLIN**, duck, or firm sack material for covering the padding, strong enough that the tacks do not cut the material.

## MEDIUM WEIGHT CARDBOARD

BLACK CAMBRIC or similar material for lining the bottom the chair.

UPHOLSTERING MATERIAL for outside covering such as frieze, art denim, tapestry, rep, mohair, sail cloth or other upholstering goods. It should be strong and durable.

GIMP OR BRAID for the final finishing if needed.

CORD, if a cording is used in finishing.

FURNITURE GLUE to fasten parts together if they are broken or loose. The plastic resin type is the most satisfactory for the amateur.

## LEARN BY MAKING A FOOTSTOOL

The essential steps in upholstering most chairs or couches are included in making an upholstered footstool with springs. It is a convenient piece of furniture, not only as a footstool, but also as a seat for children. Upholstering a stool will give good practice for upholstering a larger piece of furniture.

### Make a Footstool Frame

The outside measurements of the frame should be at least 18 inches long, 12 inches wide and 3 inches deep. Dimensions may vary to make the stool any desired size. Lumber for this frame should be 1 and  $\frac{1}{8}$  inches thick, to hold the large number of tacks and to provide enough support for the footstool legs. If yellow pine is used, select soft boards that do not split easily.

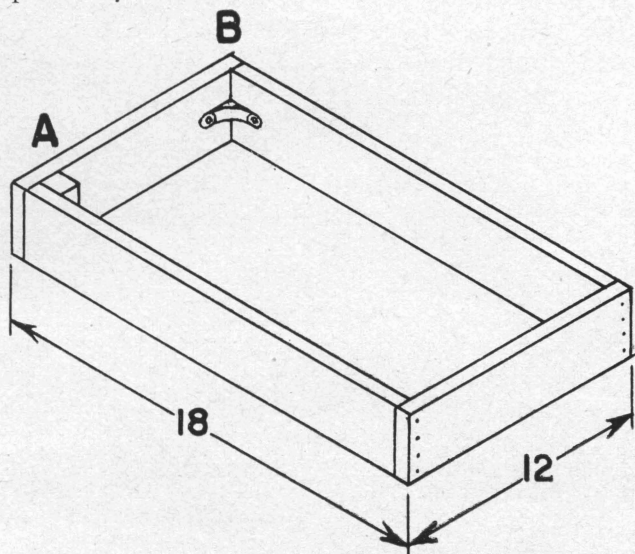

Fig. 1 Footstool frame.  
A—reinforced with small blocks of wood  
B—reinforced with metal corner plates

The inside corners of the frame may be reinforced with small blocks of wood not more than one

inch on a side (Fig. 1A) or with metal corner plates (Fig. 1B).

## LEGS FOR THE FOOTSTOOL

If you like, square legs may be built into the frame, and the legs will take the place of the block or metal reinforcement. In this case, a part of each

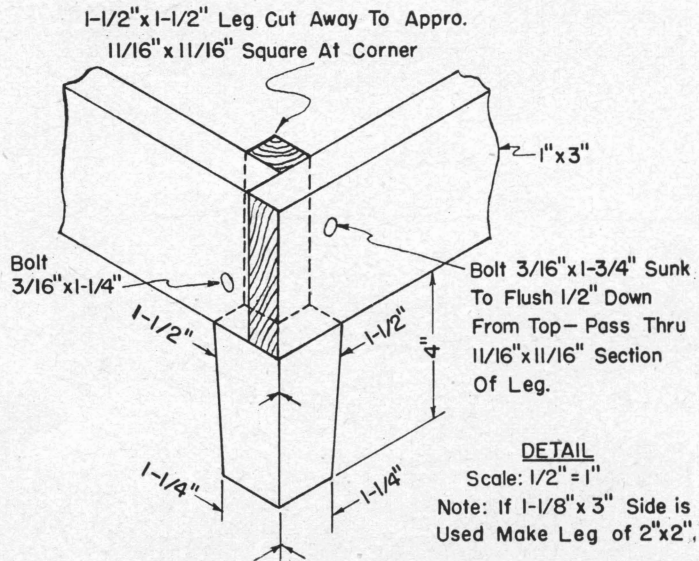

Fig. 2

leg should extend into the corner of the frame. (Fig. 2) These square legs may be three or four inches high and should taper gradually toward the bottom. In making the legs, use lumber  $\frac{13}{16}$  of an inch thick. If the frame is made of lumber more than 1 and  $\frac{1}{8}$  inch thick, then the legs will need to be somewhat larger to give plenty of support to the frame.

Turned legs of various styles may be bought from companies dealing in upholstery materials or they may be made locally. They give a professional appearance to the finished footstool. Glue and screw them into place when the stool is ready for the outside cover. Eight screws at least  $\frac{1}{2}$  inch longer than the holes in the legs are needed for attaching the legs to the frame. Finish them before they are attached to the frame.

## EIGHT STEPS IN UPHOLSTERING

These are the essential steps in all upholstering where coil springs are used:

- Provide a support for the springs
- Fasten the springs to the support
- Tie the springs
- Cover the springs
- Pad the springs
- Put on the inner covering
- Put on the outer covering
- Finishing

## SUPPORT THE SPRINGS

The springs may be supported by webbing, by wooden strips or a wooden base, or by a metal strip with notches in it for the springs.

### Place the Webbing

Strips of webbing run crosswise and lengthwise on the bottom of the footstool frame. There should be a strip of webbing under each row of springs. These strips should be placed so that the outer edges of the springs are at least  $1\frac{1}{2}$  inches from the inside edges of the frame.

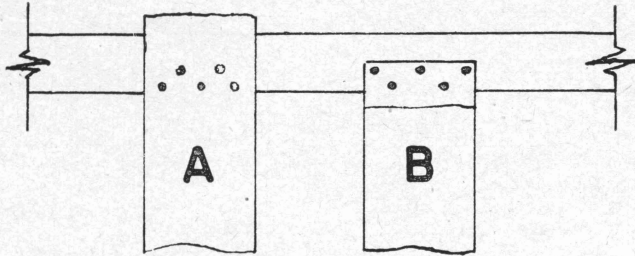

Fig. 3

The roll of webbing is used uncut, if possible, so there will be more material for stretching. The center crosswise strip is placed first. One inch of material is allowed to extend beyond the center of the frame edge, (Fig. 3A), then the webbing is tacked with four or five No. 8 tacks to the center of the rail. The end of the webbing is turned back over the first row of tacks and secured with five more tacks. (Fig. 3B). The fold of the webbing should not extend to the outer edge of the frame as this would make an irregular line on the bottom of the footstool.

The end is tacked twice. Four or five tacks are used the first time and five after it is folded. The tacks may be staggered to keep the wool from splitting.

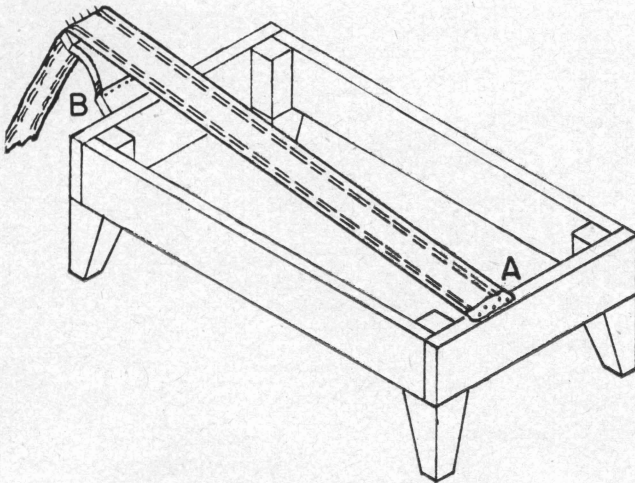

Fig. 4—A and B

A webbing stretcher is used to pull the webbing tightly across the bottom of the frame. One end of the webbing is tacked to the frame (Fig. 4A). The smooth end of the stretcher is placed against the side of the frame just below the rail at an angle. The webbing is pressed over the prongs. The stretcher is then pressed downward until the webbing is very tight. (Fig. 4B). If the webbing is long enough for the space, but too short to be stretched in this manner, a band of several thicknesses of sack material may be sewed tightly to the end of the webbing and removed after the webbing is stretched and tacked.

When the webbing has been stretched as tightly as possible, four tacks fasten it to the center of the rail (Fig. 3A). The webbing is cut off one inch from the tacks. This inch of material is folded over the tacks and five more tacks securely fasten the fold to the rail (Fig. 3B).

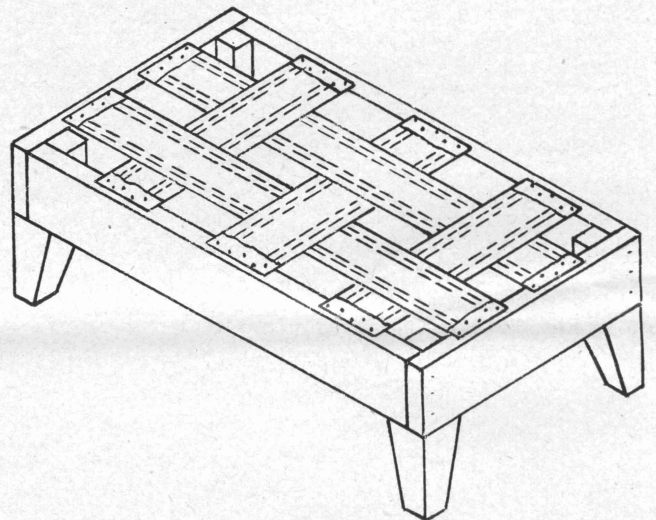
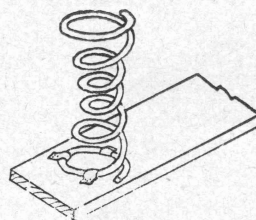

Fig. 5

The other crosswise strips are placed on either side of the center band, the outer edge of each being at least  $1\frac{1}{2}$  to 2 inches from the inside edge of the frame.

The lengthwise strips are laced with basket weave through the crosswise strips before the loose end is attached. Spacing between lengthwise strips should be about the same as that between crosswise strips. (Fig. 5).

### A Wooden Slat for Spring Support



In some chairs there are wooden strips or a wooden base under the springs, and the springs are attached to it with strips of strong cloth or leather nailed over the wires.

## Metal Slats for Springs

Metal slats are quite common. When they break, it is better to get a new metal piece. If this is impossible, take off these metal strips and replace them with webbing or with wooden slats. It is more satisfactory to replace the springs with another type that can be fastened to webbing or wooden strips, as the ones which usually come with the metal slat are tapered to such a small base that it is difficult to attach them securely.

## SET AND FASTEN THE SPRINGS

One spring is set in the center of each cross formed by the webbing. (Fig. 6). If the ends of

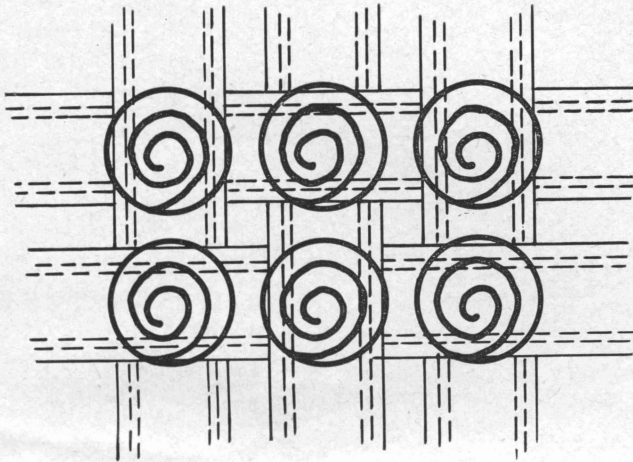

Fig. 6. A spring is set in the center of each cross formed by the webbing.

the spring wire are loose, that end of the spring with the wire curving downward is considered the top of the spring. The springs are so placed that the ends of the wire or knots in the spring come close to, but not at, points where the springs will be tied.

After all the springs are placed, they are sewed to the webbing with a large-eyed needle and a long double strand of strong mattress twine. Three stitches are made at each of the four corners of the cross

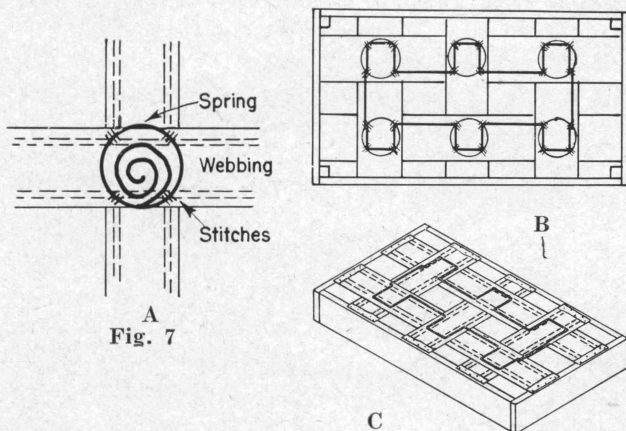

Fig. 7

in sewing the spring to the webbing. (Fig. 7A). Try to make these stitches where you can catch the two thicknesses of the webbing.

Tight stitches are made over the wire and close to it. The thread is drawn tightly to hold the spring securely in place. Long stitches are made on the bottom side from one point of fastening to the next. (Fig. 7B and 7C). All knots are kept on the same side with the springs.

## TIE THE SPRINGS

A good quality of spring twine should be used for tying the springs. Each spring is crossed by four cords. (Fig. 8).

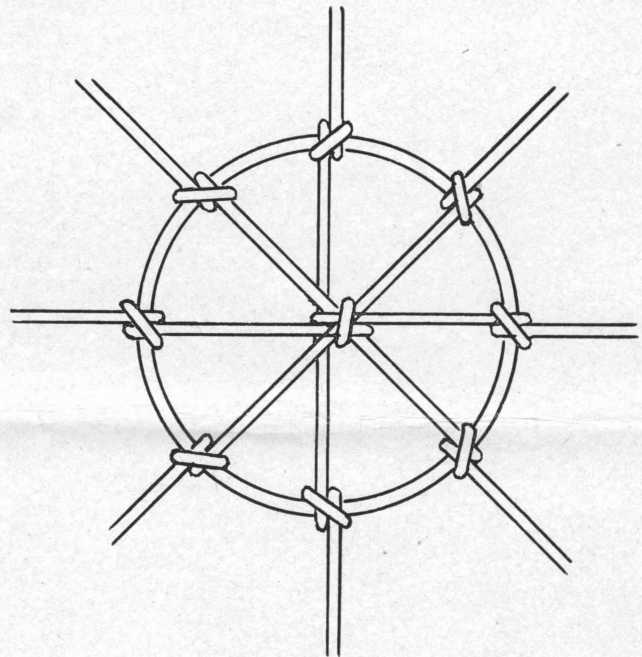

Fig. 8

## Measure the Spring Cord

Measure over the tops of one row of springs horizontally and cut twice this length of twine for each row of crosswise springs. Measure twine for the lengthwise tying and diagonals running in one direction in the same way. For the remaining diagonals add about four inches to twice the distance measured. These last diagonals need to be somewhat longer than the others because they are tied in more knots.

## Tacks to Hold Spring Cord

Next, drive two No. 12 tacks partially into the center of the top rail in line with the middle of each row of springs and far enough apart to accommo-

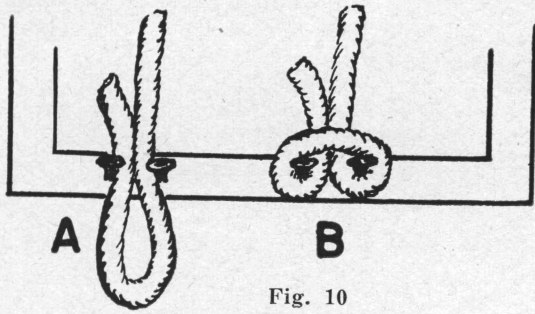

Fig. 10

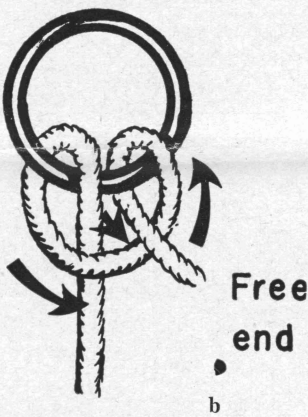
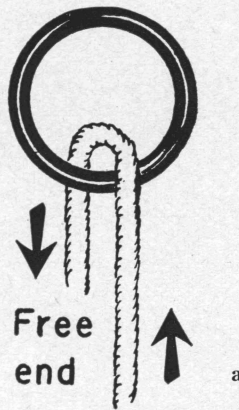

Fig. 11

date two thicknesses of spring twine. (Fig. 9). These groups of tacks will be used in fastening both crosswise and lengthwise cords.

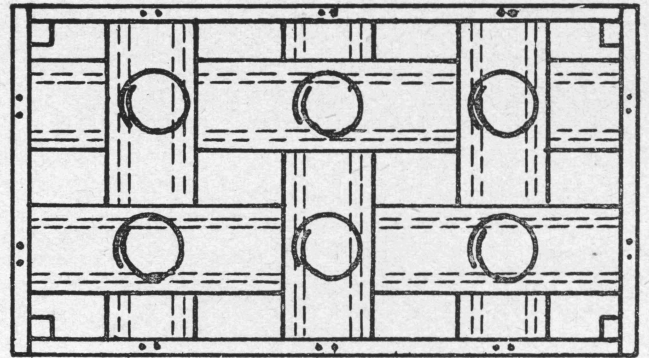

Fig. 9

In the same way, two No. 12 tacks will be driven in for the diagonal cords after the springs are tied with the cords running across and lengthwise.

#### Fasten the Spring Twine to the Frame

Beginning with the middle row of springs running across the frame, the end of one of the lengths of twine is held in a loop and placed between the two tacks nearer you, leaving about two inches of spring cord extending to the inside of the frame, (Fig. 10A). The loop is then folded back over the two tacks to form a loop around each tack (Fig. 10B).

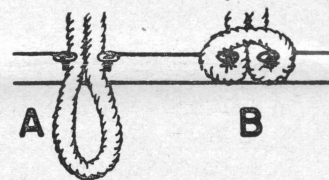

Fig. 10

The twine is drawn tightly around the tacks and the tacks driven in. Be sure that the twine is pulled well under the tack heads. Otherwise the edge of the tack head may cut into the twine.

The twine is drawn tightly around the tacks and the tacks driven in. Be sure that the twine is pulled well under the tack heads. Otherwise the edge of the tack head may cut into the twine.

#### Make the Knots Over the Springs

Working in the opposite direction, the spring is pushed down firmly with the left hand so that the edge of the top coil nearer the rail is about even with the edge of the the rail and the knot is then made to hold the spring in place. These are the steps in making the knot:

1) The spring is held in position with the palm of the left hand.

2) With the right hand, the free end of the twine is passed over the edge of the spring nearer the rail, back under the wire and drawn out to the left. (Fig. 11a).



3) The twine is drawn tight enough to get the spring in the proper position and it is then held firmly in place with the left thumb and index finger. Do not let the cord slip after reaching this point.

4) The free end of the twine is then passed over the wire to the right; a loop of this twine is left behind the wire; the long end of the twine is passed back under the wire and through the loop. (Fig. 11b).

5) The twine is pulled tightly away from the worker, the thumb and index finger holding the cord tightly until the knot is complete. When made correctly, this knot forms a figure 8. (Fig. 11c). The knot cannot slip and will not pull out if the twine wears through at any point. The twine is then stretched across the top of the spring and a similar knot made on the opposite side of the coil.

The second spring in the row is pushed into a position corresponding to that of the first spring. There should be the same spacing between the springs at the top as at the bottom. This spring is tied in the same manner as the first spring. Each row of springs is pushed down into proper shape with the help of another person, and the end of the twine is fastened by means of the two tacks previously placed in the rail.

In fastening the cord with the tacks after the completion of one row of tying, place the cord between the two tacks. Twist it around one and brace it against the outside of the other while driving in the first tack. Then place the free end of the cord back toward the springs. Leave it loose enough to make an outward twist and slip it over the second tack. Draw the cord tightly and fasten it by driving in the tack. This is a trifle different than the fastening made as you begin the tying.

Before the first tack is driven down over its

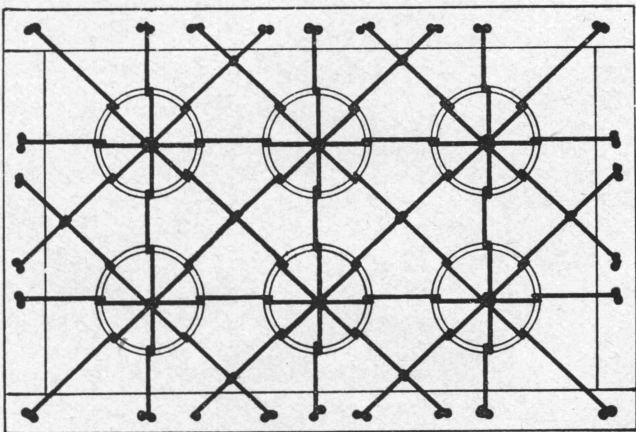

Fig. 12

loop of twine, note the symmetrical shape of the curve made by the row of tied springs and make adjustments if it is not satisfactory. The contour of this middle row of springs will serve as a guide for that of all the other rows in the footstool; therefore if it is not a nicely rounded curve, it is easier to make the changes at this point than to try to remedy it later.

The springs in the additional crosswise rows, the lengthwise rows and the diagonals in one direction are tied in the same way. The diagonals in the remaining direction are knotted over all cords as well as over the wires, including the crossed cords in the center of each spring. (Fig. 12). A general rule to remember is that the twine is knotted at every wire and cord which is *not to be crossed again*. When the tying is complete, the seat should present a slightly rounded appearance with every spring standing erect. (Fig. 13).

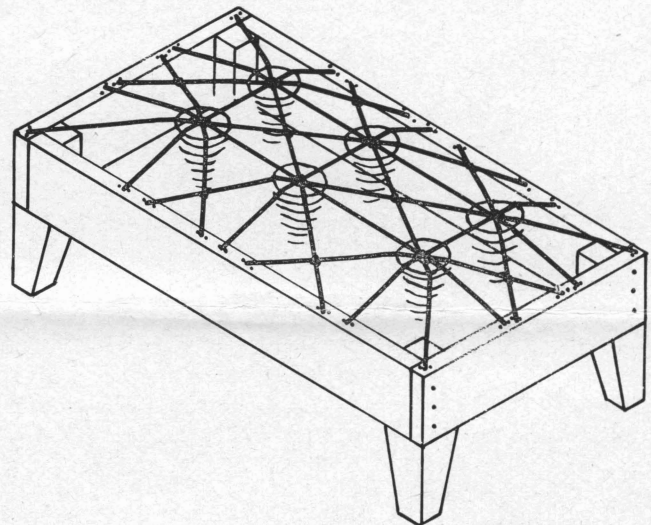

Fig. 13

Sometimes the twine used to tie springs in a chair has broken and the spring nearest the break pushes up against the padding. This makes the seat uncomfortable and unsightly. To correct this, take off the covers and padding, untie the length of twine where the break occurred, and if the springs are still good, use new twine and tie the row of springs affected. This is a good time to replace any other twine that looks weak.

#### COVERING THE SPRINGS

Cut the material for covering the springs large enough to extend approximately  $2\frac{1}{2}$  inches on all sides of the frame. This extra is used later to make a padded roll. The burlap or material for the spring covering is laid over the springs, drawn tightly enough to insure smoothness and tacked down

with No 8 tacks just inside the edge of the rail on all sides. If the wood shows a tendency to split, use about half of the tacks in No. 3 size. Sew the cover to the top coils of the springs with a curved upholstery needle and mattress twine to hold it even more securely in place.

### The Roll Edge

The sharp edge of the footstool is padded by arranging a small even layer of moss or other padding on top of the tacks holding the spring cover. Turn back the edge of the covering on each side, making a tight, even roll. Sew the roll in place with a strong thread such as carpet thread, and a small curved needle. The roll should extend over the edge of the wood a trifle, just enough that the hard sharp edge of the frame will not be felt. At the

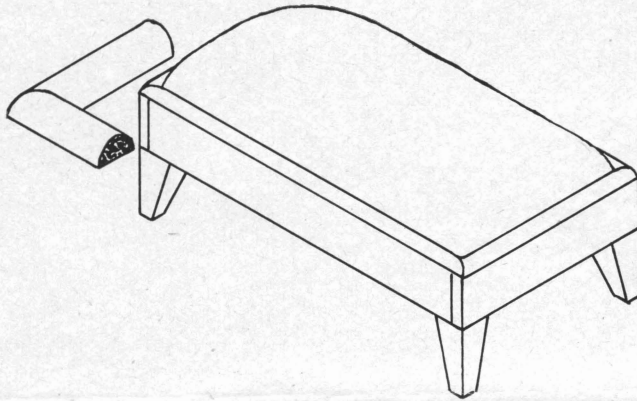

Fig. 14

corners the material should be mitered and the padding adjusted to make this portion of the roll the same size as that on the sides of the frame. (Fig. 14).

### Padding

The padding is placed next. The moss or coarse padding material, the same as that used for

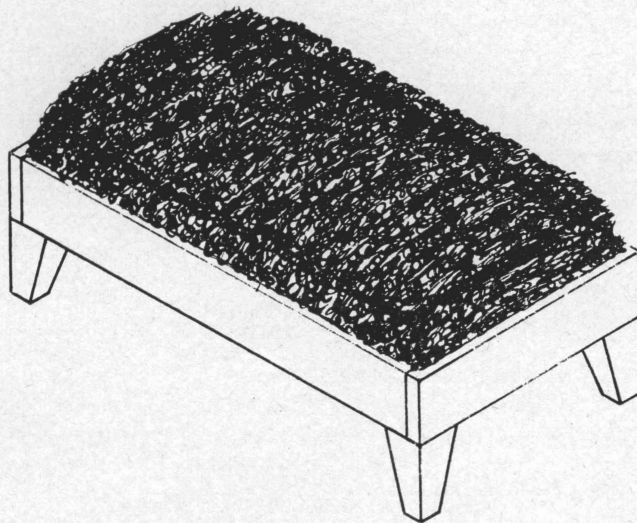

Fig. 15

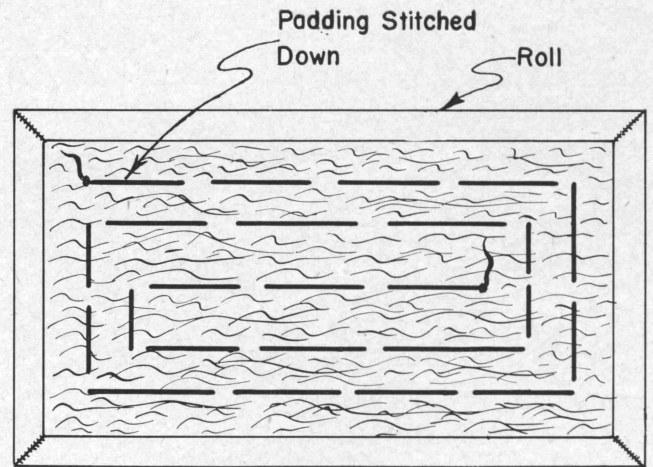

Fig. 16

the roll, is fluffed by pulling apart all lumps or thick sections and laid in even, thin layers over the spring cover, just covering the outer rolls. (Fig. 15).

It should be built up with straight even sides and corners. Be sure that it does not bulge over the edges of the frame. Enough of this padding should be used to keep the springs from being felt through the padding and to build the stool to the desired height.

To prevent the padding from slipping or settling, sew it down firmly to the spring cover with a 6-inch curved upholstery needle and mattress twine, using the twine doubled. While it should be sewed firmly, guard against pulling it down so tightly that it will be lumpy.

The padding may be sewed to the spring cover as shown in Fig. 16. Keep the long stitches on top and the short stitches on the bottom.

A layer of upholster's cotton batting or sheet wadding is placed over the padding to insure smooth-

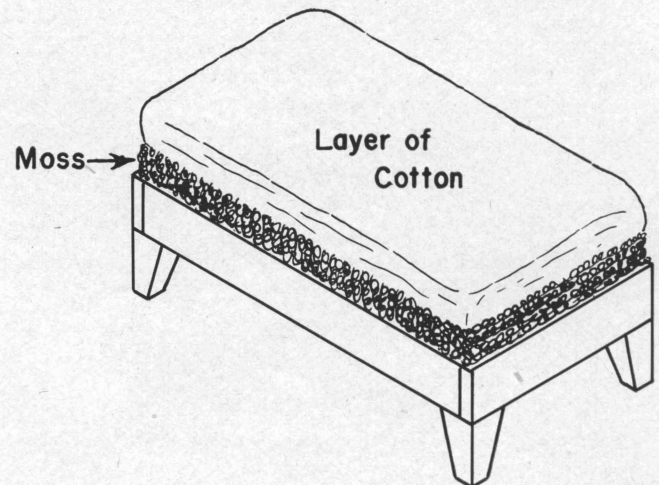

Fig. 17

ness and to prevent the ends of the coarse padding from working through the outside cover. (Fig. 17). The cotton batting can be made at home or brought from an upholstering supply company. When the batting is made at home, be sure to keep it even and free from lumps.

### COVER THE PADDING

The padding is covered with a piece of very firm heavy muslin, duck or strong sack material. It is important to draw this covering very tight in order that the finished upholstery will be smooth and tailored in appearance. The muslin is tacked with No. 3 tacks first along the center of each side and then the corners are tacked. Take care that the threads of the muslin run straight with the lines of the stool. Tacks for holding this cover should be placed about  $\frac{1}{2}$  inch or  $\frac{3}{4}$  inch below the edge of the frame. As it may be necessary to readjust the muslin covering, it is advisable to drive the tacks only partially in until the material is fitted satisfactorily.

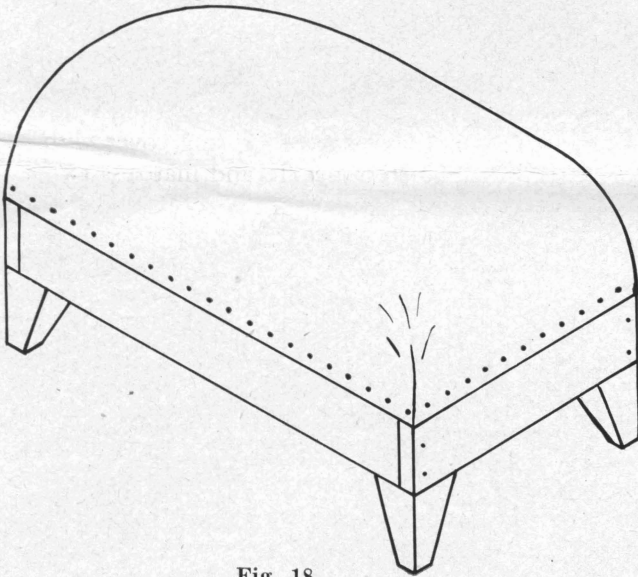

Fig. 18

All fullness is pulled out at the corners to give a smooth rounded contour. The secrets of good fitting are: First, to pull the muslin with the thread of the material in opposite directions at the same time, the strongest pull being toward the line of tacking; and second, to use a large number of small tacks placed fairly close together. (Fig. 18).

The muslin cover may be fitted around the corners as in Fig 19. Stretch the material around corner and tack. Cut away surplus and fold loose material into a pleat and tack down. (Fig. 19).

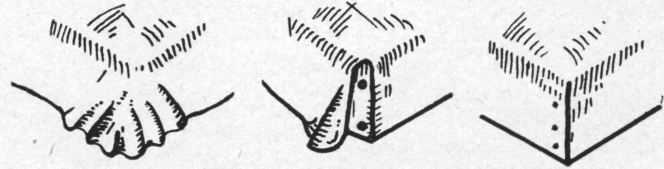
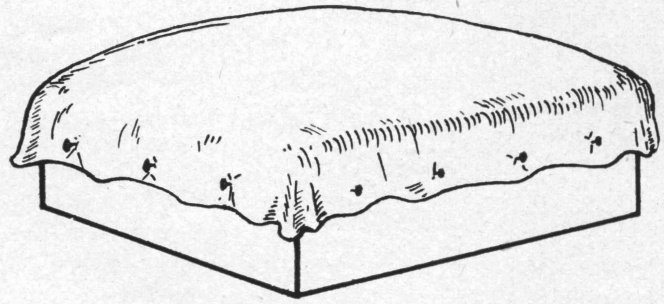

Fig. 19

After the muslin cover has been smoothly fitted and all the tacks have been driven in, the muslin should be trimmed evenly about  $\frac{1}{2}$  inch to  $\frac{3}{4}$  inch below the tacks.

### PUT ON THE OUTSIDE COVER

Two customary methods are used in finishing the outside of the upholstered footstool.

1) If the frame is made of attractive wood and the lower part of the frame is to be left uncovered, the wood should be finished before the upholstering is begun. In that case, the outside cover should be put in the same way as that used for the muslin cover, except that the row of tacks securing the outside cover is just below the tacks for the muslin cover. A strip of braid or gimp harmonizing in color with the upholstering material is glued or tacked over

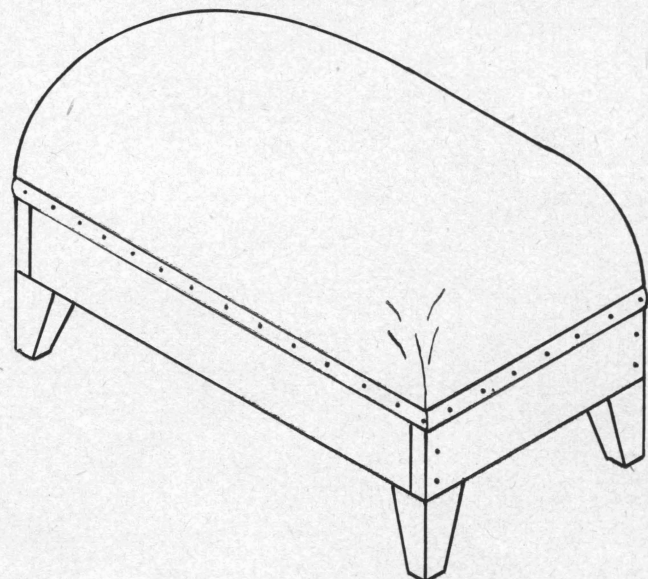

Fig. 20

the raw edge of the upholstering material. (Fig. 20). If tacked, gimp tacks may be used. Place gimp tacks in a fence row fashion. If large-headed finishing tacks are used, they may be spaced evenly and closely together.

2) If the frame is to be completely covered with the upholstery material, the first step is to place the top cover in the same manner as above, omitting the gimp or braid.

## FINISHING

### Cording

A piece of cable cord long enough to extend around the frame is covered with a 2-inch wide bias strip of the same material as the outside cover or of harmonizing material, having the same wearing quality as the outside cover. The cording is placed high enough to lie just above the edge of the rail.

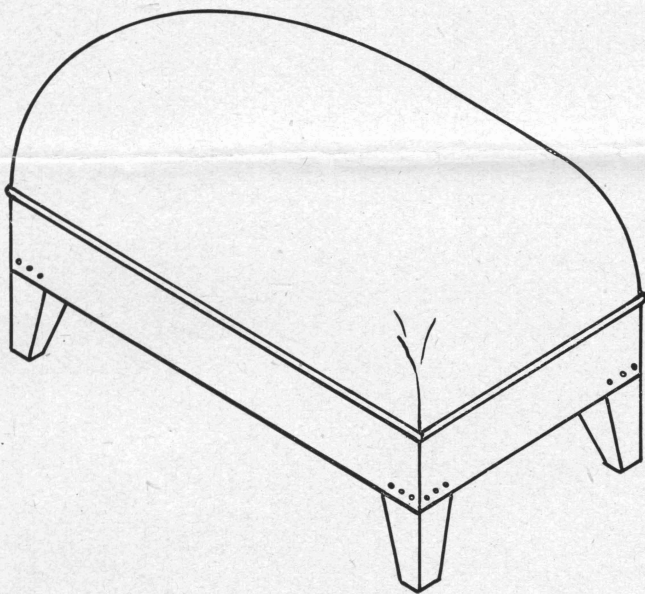

Fig. 21

(Fig. 21). The cording should fit very snugly. Using a running stitch, sew it in place with a small curved upholstery needle and strong thread.

### Boxing

A band of the upholstery material, cut 2 inches wider than the width of the frame, is turned with the right side toward the stool and with one raw edge

in line with the raw edges of the cording. This boxing should fit snugly. After securing this band with a few tacks, a 1 inch or 1½ inch wide strip of light weight cardboard is placed over the edge of the band, pushed tightly against the lower side of the cording and tacked at intervals of 1½ inches slightly below the upper edge of the cardboard strip. (Fig. 22). The cardboard holds the cording firmly in place and gives it a clear-cut tailored appearance. Guard against tacking the cardboard so that the tack head extends above it, as this eventually will cut into the cloth.

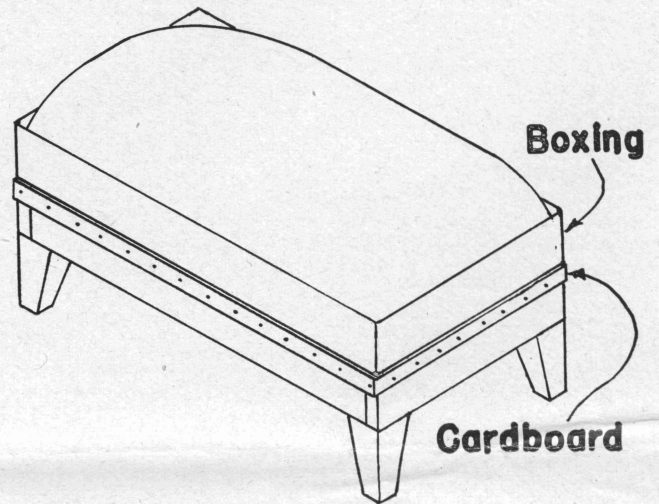

Fig 22

### Pad the Boxing

A fairly thin band of cotton padding, wide enough to extend from the top of the cardboard strip to the bottom of the frame, is laid over the frame and tacked just enough to keep it in place. The band of upholstery material is turned down over the cotton padding. Be careful in turning the boxing to prevent pulling the edge of the cotton out of place.

### Fit Boxing Around the Legs

At the corners where the legs are attached, the lower edge of the upholstery boxing is slit diagonally toward the point where the outer corners of the footstool legs and the lower edge of the frame meet. (Fig. 23A). The material is folded under at this point, so that the fold fits around the upper edge of

the leg without showing any of the wooden frame; gimp tacks or large-headed finishing tacks are driven in around the corners near the fold of upholstery material at intervals of  $\frac{1}{4}$  or  $\frac{1}{2}$  inch. (Fig. 23B). The flaps of material left on the ends of each straight side of the upholstery band are turned under. (Fig. 23C).

The bottom edge of the outer cover is turned under the frame as shown in Fig. 23D, and is held in place by No. 3 tacks as far from the outer edge of the frame as they can be driven in.

Needle point and hooked covers present problems in connection with the boxing and fitting around the legs, when the wooden frame is to be covered entirely with the material. It is better to use them as covers for stools where the wooden frame is left uncovered.

#### Attach the Lining

When all the work of upholstering has been completed, the footstool should be turned upside-down and lined with a piece of black cambric or similar material, cut the size of the frame, turned under  $\frac{1}{2}$  inch on all sides and tacked with No. 3 tacks or sewed in place. (Fig. 24). With narrower boards of inferior lumber, it is better to sew the lining in place with a small curved needle. The lining gives the footstool a finished appearance; it also prevents bits of padding from falling out on the floor and less dust reaches the webbing and springs.

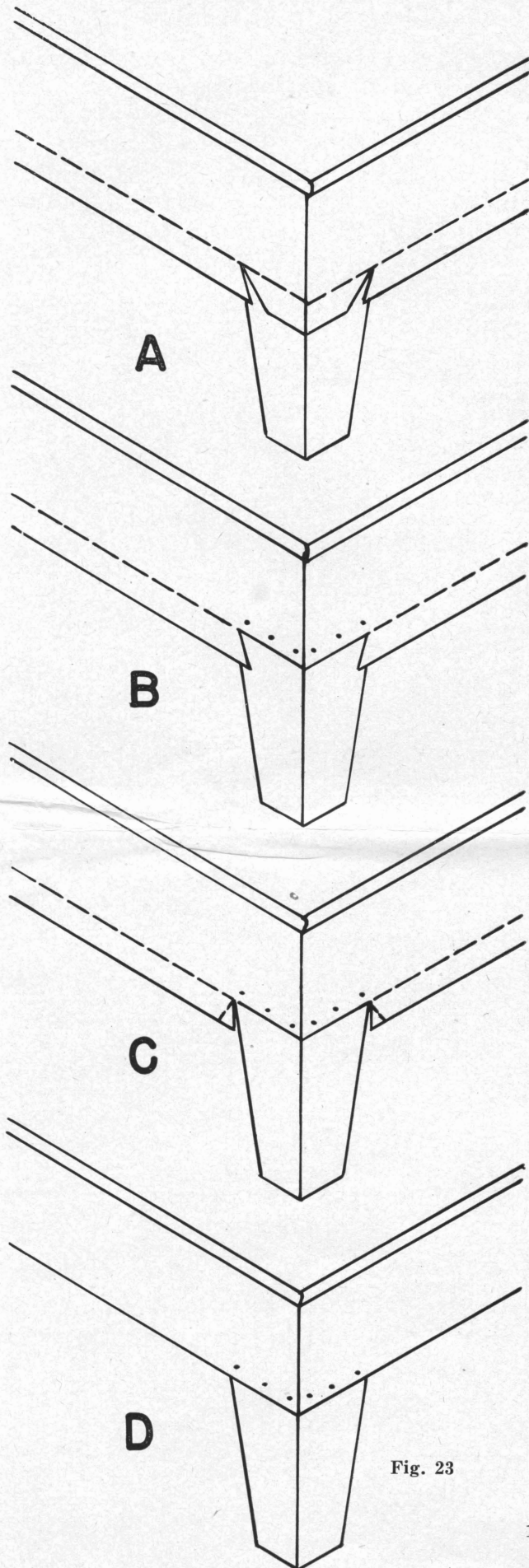

Fig. 23

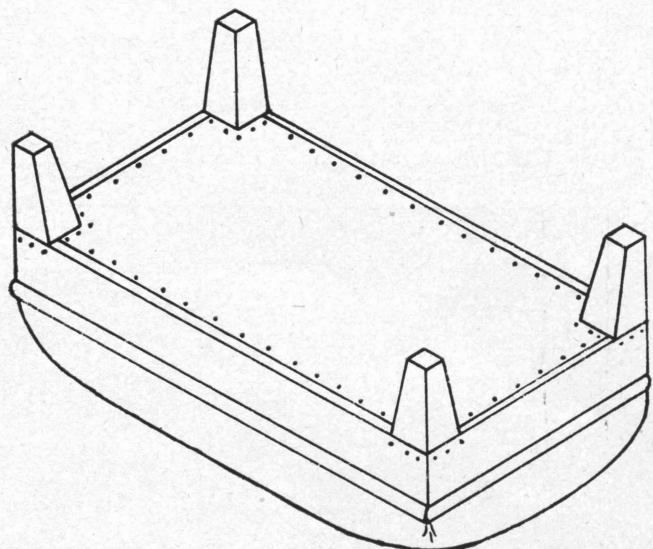

Fig. 24

**UPHOLSTER A FOOTSTOOL  
WITHOUT SPRINGS THIS WAY**

Make a footstool frame as described at the beginning of the bulletin. The top of the frame is covered with a solid wood foundation for padding. This type of construction makes a satisfactory stool from the standpoint of appearance but it is not as comfortable as the one with spring construction.

First, tack a piece of burlap or heavy material over the wooden top. Coarse padding of curled hair or moss is then arranged on the burlap and sewed in place. Place a sheet of cotton padding over

the coarse padding. The muslin cover and the outside cover are both put on in the same way as for footstools with spring construction. The chair with a padded section on a solid wood bottom is a common example of this type of upholstery.

The following drawings give details for building a footstool with legs which extend up on the outside of the frame, rather than on the inside as shown in Fig 2. A cushion can be inserted in this type and the frame given the same finish as the legs.

**UPHOLSTERED STOOL** Scale:  $3/16'' = 1''$

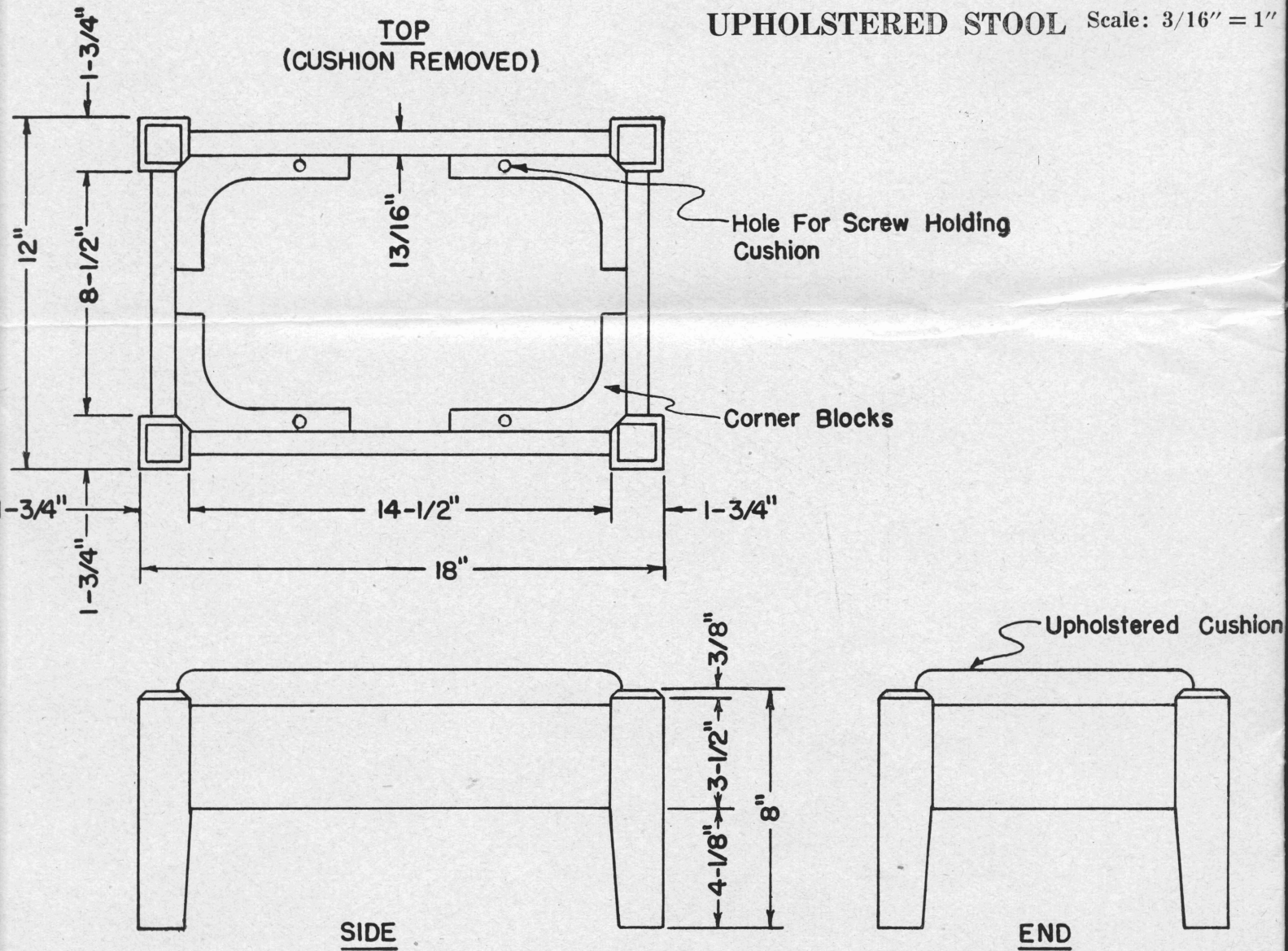

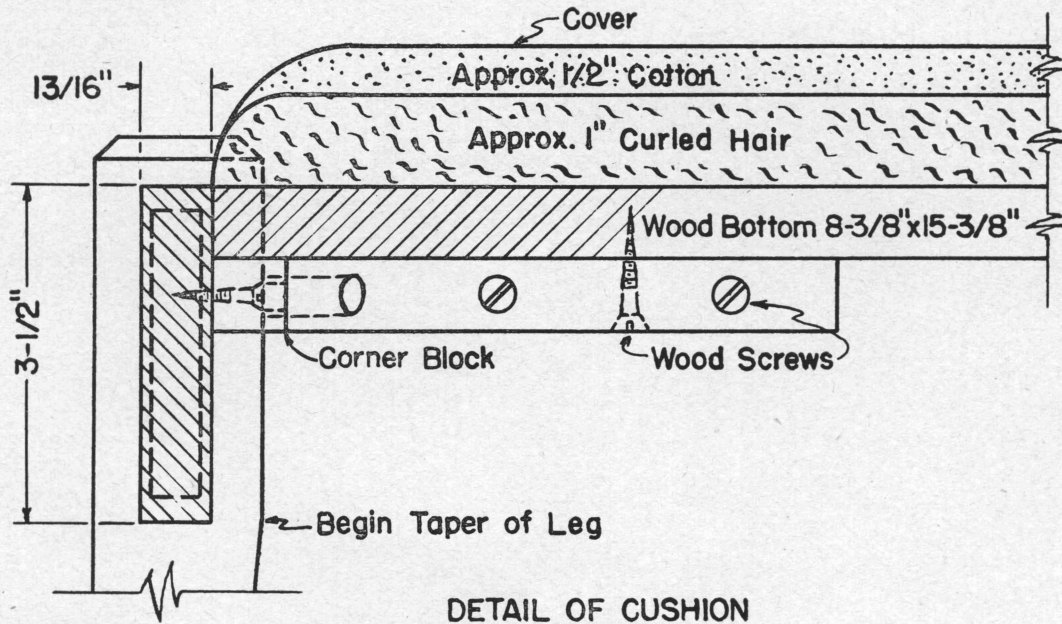

DETAIL OF CUSHION  
CORNER

Scale: 1/2" = 1"

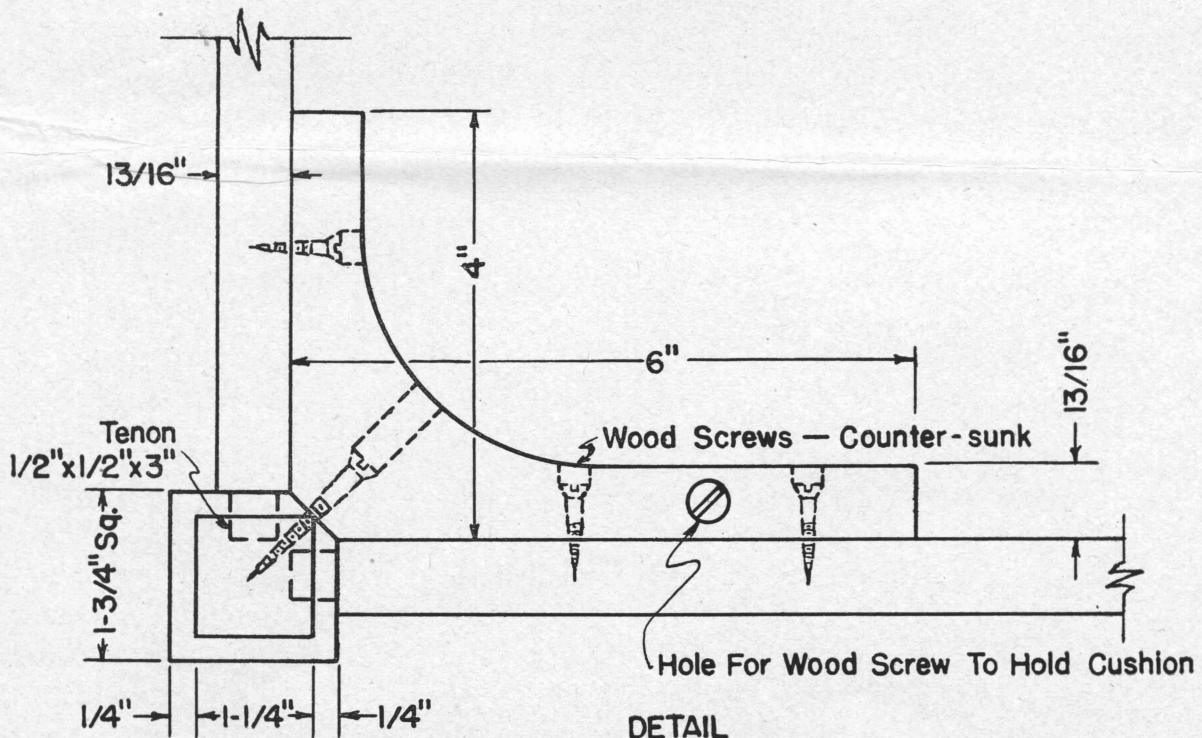

DETAIL  
POST AND CORNER BLOCK

Scale: 1/2" = 1"

All Joints To Be Glued

---

Cooperative Extension Work in Agriculture and Home Economics, Agricultural and Mechanical College of Texas, and United States Department of Agriculture Cooperating. Distributed in furtherance of the Acts of Congress of May 8 and June 30, 1914.  
10M-5-48