

# Testing and Evaluation of a Power Factor Correction Unit for Energy-Saving Potential

A. Al-Mulla  
Associate Research Scientist  
Department of Building and Energy Technologies  
Environment and Urban Development Division  
Kuwait Institute for Scientific Research  
P.O. Box 24885, 13109, Safat, Kuwait

A. Alotaibi  
Research Associate

## ABSTRACT

Power factor correction (PFC) is an important technology that can be used to enhance power quality. It was noted that the power factor was low for packaged air-conditioning (PAC) units utilized in residential buildings in Kuwait. To study the impact of PFC units, a PAC unit was selected, a PFC unit was installed, and three cases were developed to assess their energy-saving potential. It was found that the PFC unit was able to correct the power factor from 0.61 to 0.96. The reactive power was then reduced from 13.9 to 3.0 kVAR (kilo volts amps reactive), the apparent power was decreased from 17.5 to 11.0 kVA (kilo volts amps), and the current was reduced from 23.4 to 14.5 amps. The Ministry of Electricity & Water (MEW) in Kuwait is expected to be the major beneficiary of installing PFC units since MEW does not charge consumers for the cost of reactive power..

Key words: PFC unit, power factor, reactive power, active power and apparent power.

## INTRODUCTION

The Energy Efficiency Technologies Program at the Kuwait Institute for Scientific Research (KISR) focuses much of its attention on reducing the national power demand and energy consumption in air-conditioned (A/C) buildings since A/C systems account for nearly 70% of the peak electrical demand and 45% of the annual energy consumption (Al-Marafie et al, 1989). A number of studies have been focused on improving the energy efficiency and conservation in buildings. The Energy Conservation Code of Practice, developed by the KISR and implemented by the Ministry of Electricity & Water (MEW) in Kuwait in 1983 for all types of air-conditioned buildings has been a remarkable success. Without this code, the country would have needed 3,000 MW of additional power generation capacity.

The accumulative savings due to the code are estimated to be well over KD. 3.0 billion (Meerza and Maheshwari, 2002). A revised code is under implementation since 2010, which further enhances the energy efficiency in buildings. Energy auditing, the first step towards a comprehensive energy management plan in existing buildings, has been carried out in a number of major buildings since 1995, leading to reductions in annual energy consumptions of well over 20% (Maheshwari et al, 1997, Al-Ragom et al, 2002, Al-Ragom et al, 2005, Hajiah et al, 2007). In the summer of 2006, load shedding was scheduled in some areas in Kuwait due to failures of some of the power generating units. The MEW realized the importance of reducing the peak load in the summer of 2007 to avoid any scheduled load shedding. Thus, the MEW assigned the KISR to develop the smart strategies to effectively operate A/C and lighting systems in government buildings, which have been found to be extremely effective to manage national load (Al-Mulla et al, 2008).

It was observed that the power factor was low for packaged air-conditioning (PAC) units installed in one of the KISR's buildings. The power factors of two A/C units (old and newer units) were compared to each other, as illustrated in Fig. 1. The old and newer PAC units were installed in 1986 and 2005, respectively. The power factor (PF) of the old PAC unit was ranged between 0.70 and 0.76, however the PF for the newer PAC unit was about 0.82.

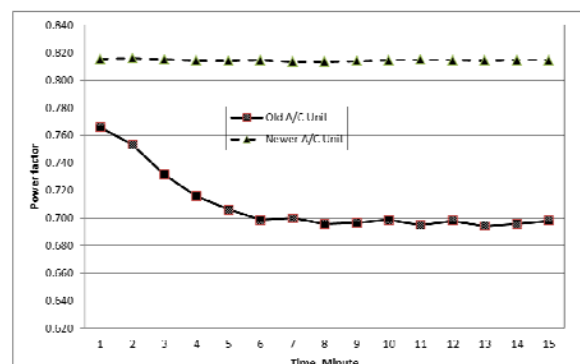

**Figure 1. Power Factors of Old and Newer PAC A/C Units in One of the KISR’s Buildings**

To correct the power factor and enhance the power quality, a Power Factor Correction (PFC) unit is utilized, which is capable of storing and supplying reactive power to the inductive motors and loads for different types of electrical units such as A/C units. Power consists of both active (real) and reactive power. Consider that all induction loads consume two kinds of power: reactive power and the active power of kilowatts. The active power performs the work of a motor. The function of reactive power is to develop the electromagnetic fields (EMFs) to ground the induction windings of the motor. In Kuwait, consumers only pay for the active power and energy used in kWh. A PFC unit stores the reactive power needed to create EMFs within the inductive loads. As the motor operates, this reactive power is “pulled and pushed” to and from the PFC unit by the motor. The reactive power is then reclaimed and recycled by the PFC unit, resulting in reactive power being supplied on the spot.

In this project, three cases were developed to assess the impact of the PFC unit in energy-saving potential for PAC units. The benefits of installing PFC units were investigated.

**METHODOLOGY**

The approach adopted for executing this work was divided into a number of tasks which are explained below:

**Selection of Motor and Installation of a Power Factor Correction Unit**

A PAC unit was selected and then the PFC unit was installed for the PAC unit. Figure 2 illustrates the schematic of the testing procedures of the PFC unit. Additionally, two power analyzers were installed. The first power analyzer was installed at the main distribution box at the roof top. The location of this power analyzer is labeled the panel side. The other power analyzer was installed after the power factor correction unit, and is labeled the load side. The power analyzer has the ability to measure the voltage, current, active, reactive, and apparent power, power factor, frequency and harmonic value.

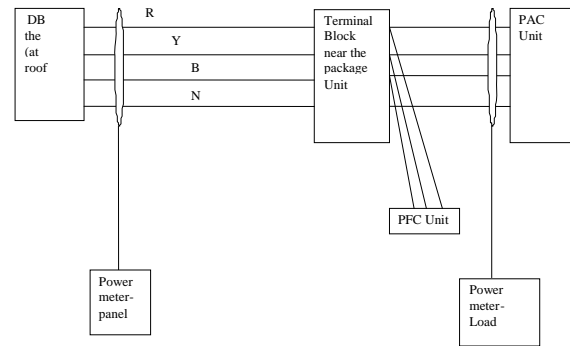

**Figure 2. Diagram of the Installation of the PFC Unit and Power Meters**

**Analysis of the Collected Data**

The data was collected from the power analyzers for a period of 5 days. Once the installation was completed, the A/C unit was turned on while the PFC unit was switched off for a period of 24 hours to establish the base load of the PAC unit. After the 24-hour period, the PFC unit was switched on when the PAC unit was off and the last case was when both the PFC and PAC unit were on. Three case studies were developed for this experiment, as illustrated in Table 1. The results from the power analyzer were collected and analyzed.

**Table 1. Different Case Scenarios**

Case	Status of A/C Unit	Status of PFC Unit
Case 1	OFF	OFF
Case 2	ON	OFF
Case 3	ON	ON

There are two important relationships correlating active power (W), reactive power (VAR), and apparent power (VA) and PF, which is also illustrated in Fig. 3:

$$PF=W/VA \dots\dots\dots(1)$$

$$(VA)^2=(W)^2+(VAR)^2 \dots\dots\dots (2)$$

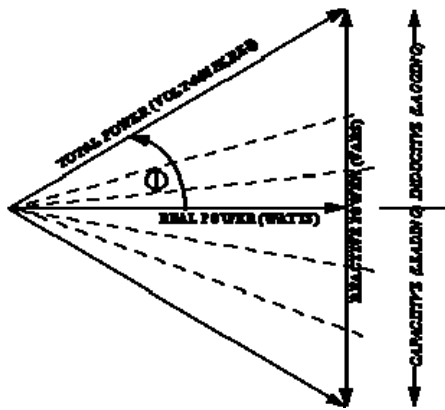

Figure 3. Power Factor Triangle

**RESULTS AND DISCUSSIONS**

The three cases were developed to investigate the impact of the PFC unit for energy-saving potential, as illustrated in Table 1. Additionally, the effect of improving the power factor was initially investigated and then the values of active, reactive, and apparent powers were calculated for both panel and load sides for the three cases.

**Power Factor**

The value of the PF was 0.42 (case 1) when both the PAC and PFC units were off, as shown in Fig. 4. This indicated that a small amount of electricity was being consumed by the fan of PAC unit. In case 2, the value of PF was 0.61 when the PAC unit was on while the PFC unit was off. It should be noted that the power factor for this PAC unit was relatively low compared with the standard power factor of a working PAC A/C unit, which ranges from 0.75 to 0.85. In case 3, the power factor was improved to 0.96 when the PFC unit was on. This is considered to be a major advantage of the PFC unit on improving the PF of the A/C unit.

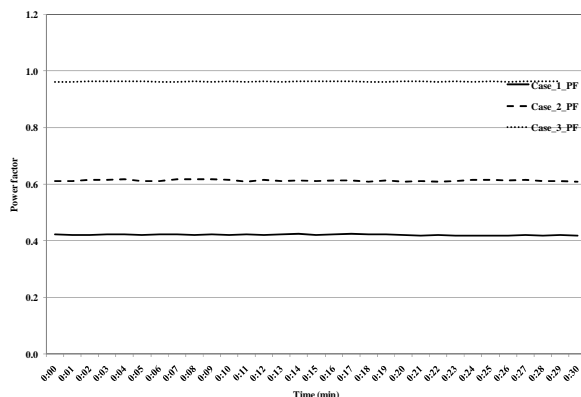

Figure 4. Values of the Power Factor for the Three Cases

**Active Power**

Active power was only affected by the status of the PAC unit at both the panel and load sides. However, no changes in the values of the active power were reported when the PFC unit was engaged, as shown in Fig. 5. The value of the active power was about 0.9 kW when the PAC unit was off. The value of the active power increased to approximately 10.7 kW when the PAC unit was on. The results clearly indicated that the PFC unit has no effect on the active power.

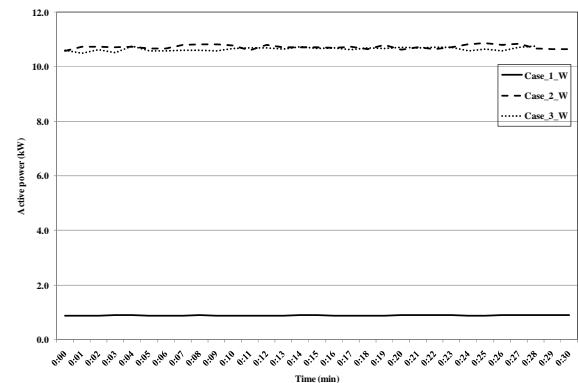
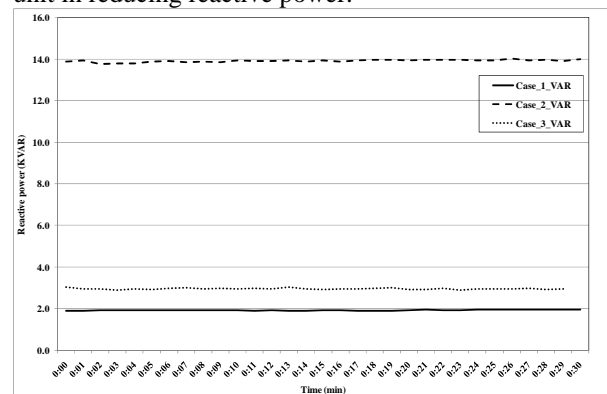

Figure 5. Values of Active Power for the Three Cases at the Panel Side

**Reactive Power**

The value of reactive power was 1.9 KVAR when the PAC unit was off (case 1); the value of reactive power was increased to 13.9 KVAR at the load side when the PAC unit was on and the PFC unit was off (case 2), as illustrated in Fig. 6. In case 3, the value of the reactive power was reduced to 3 KVAR when both the PAC and PFC units were on. This indicated that a reduction of 11 KVAR in reactive power was achieved due to the engagement of the PFC unit. This is considered to be a major advantage of using PFC unit in reducing reactive power.



**Figure 6. Values of Reactive Power for the Three Cases at the Panel Side**

### Apparent Power

The value of the apparent power was 2.1 KVA (case 1) when both the PAC and PFC units were switched off, as illustrated in Fig. 6. In case 2, the apparent power was increased to 17.5 KVA when the PAC unit was on. Figure 7 illustrates that the apparent power was then reduced to 11.0 KVA (case 3). This illustrated that a reduction of 6.5 KVA was achieved in apparent power due to the PFC unit.

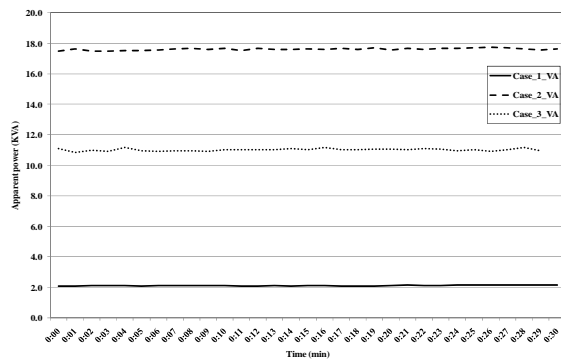

**Figure 7. Values of Apparent Power for the Three Cases at the Panel Side**

### Benefits of PFC

Installing this PFC unit had a number of advantages in terms of improving the power factor of the PAC unit, which can be summarized as follows:

1. Protection from voltage fluctuation.
2. Reduction of reactive power (kVAR).

The MEW is the major beneficiary for the introduction of the PFC unit since the MEW is fully responsible for the cost of the reactive power. However, the consumer will benefit due to the enhancement of the quality of power within the building and an increase in the lifespan of the PAC unit.

To establish the economic viability of the PFC unit, detailed cost-benefit analysis shall be carried out to estimate the cost of installing PFC units for individual PAC units throughout Kuwait. Then, the

### **REFERENCES**

- Al-Marafie A.M.R, R.K. Suri, and G.P. Maheshwari, 1989. Energy and power management in air-conditioned buildings in Kuwait. *Energy, the International Journal* **14** (9): 557-562.

financial and environmental benefits shall be calculated to establish clearly the economic feasibility of installing PFC technology for the PAC units in Kuwait.

### Review of Similar Studies

There are a number of studies similar that utilized PFC units. One of those studies was done by Advanced Energy in North Carolina. They had installed several PFC units in farm houses. The result showed clearly drastic impact on improving the power factor of those buildings but no significant effect on active (real) power was measured [5].

### **CONCLUSIONS AND RECOMMENDATIONS**

This objective of this project was to study the impact of a PFC unit on increasing the power factor of a PAC unit. Three case studies were developed to assess the impact of the PFC unit in saving energy. The results can be summarized as follows:

1. The PFC unit was able to increase the power factor from 0.61 to 0.96. The reactive power was then reduced from 13.9 to 3.0 KVAR. The apparent power was decreased from 17.5 to 11.0 KVA. Finally, the current was reduced from 23.4 to 14.5 amps.
2. The MEW is the major beneficiary for installing PFC units for individual PAC units.

It is highly recommended that a detailed cost-benefit analysis is carried out to estimate the cost of installing PFC units for individual PAC units throughout Kuwait. Then, the financial and environmental benefits shall be calculated to establish clearly the economic feasibility of installing PFC technology for the PAC units in Kuwait.

### **ACKNOWLEDGMENTS**

The authors would like to acknowledge Ties International for providing the power factor correction unit to perform this experiment.

- MEW. 2009. Energy conservation program, Revised Code of Practice. Ministry of Electricity and Water, Kuwait, Report no. MEW, 2009/Revised R-6.
- Al-Ragom, F, G.P. Maheshwari, A. Al-Nakib, F. Alghimlas, R. Al-Murad and A. Meerza. 2002. Energy auditing of KISR's main building. Kuwait Institute for Scientific Research, KISR **6287**, Kuwait.
- Al-Mulla, A., G. P. Maheshwari, D. Al-Nakib, A. ElSherbini, F. Alghimlas, H. Al-Taqi , Y. Al-Hadban, H. Ishaqali, R. Alasser, A. Al- Awadhi, and A. Al-Farhan. 2008. Smart operation of air-conditioning and lighting systems in government Buildings for peak power reduction. EU046C, Final Report No. KISR 9231, Kuwait.
- Fitzpatrick, S and M. Murray. 2009. KVAR unit performance field measurement. Advanced Energy. North Carolina.