

**CRITICAL COMPONENTS FOR NOVEL DIRECT
CARDIAC COMPRESSION DEVICE**

A Thesis

by

LEWIS DALE HARRISON JR

Submitted to the Office of Graduate Studies of
Texas A&M University
in partial fulfillment of the requirements for the degree of

MASTER OF SCIENCE

December 2004

Major Subject: Biomedical Engineering

**CRITICAL COMPONENTS FOR NOVEL DIRECT
CARDIAC COMPRESSION DEVICE**

A Thesis

by

LEWIS DALE HARRISON JR

Submitted to Texas A&M University
in partial fulfillment of the requirements
for the degree of

MASTER OF SCIENCE

Approved as to style and content by:

John C. Criscione
(Chair of Committee)

James E. Moore Jr.
(Member)

Christopher M. Quick
(Member)

William A. Hyman
(Head of Department)

December 2004

Major Subject: Biomedical Engineering

ABSTRACT

Critical Components for Novel Direct

Cardiac Compression Device. (December 2004)

Lewis Dale Harrison Jr, B.S., Texas A&M University

Chair of Advisory Committee: Dr. John C. Criscione

According to the American Heart Association, there are currently 5 million Americans diagnosed with congestive heart failure and that number is steadily increasing (AHA, 2003). The alarming problem of congestive heart failure and other related medical complications has created a need for devices that not only assist the heart but also help the heart to grow and remodel back to its normal configuration. Currently, there are several direct cardiac compression devices (DCCDs) that do assist the heart, however, they do not help the heart to grow and remodel correctly. Dr. John C. Criscione of Texas A&M University has proposed a novel DCCD, in which the compression of the device reinforces the natural curvature of the heart, helping it to grow and remodel correctly. It is hypothesized that with the support of the device, the cells of the heart will be stimulated to grow and remodel back to their normal size and return to their proper function. Two key components necessary to the novel DCCD were designed and constructed for this study. The first component was an adjustable outer shell which enabled the device to become smaller as the failing heart returned to normal size. The second component was an inflatable inner membrane that applies direct pressure to the outer wall of the heart in a way that promotes physiological stress and strain patterns.

ACKNOWLEDGMENTS

I would like to acknowledge Kate Utley for helping in the construction of the inner membrane.

TABLE OF CONTENTS

	Page
ABSTRACT	iii
ACKNOWLEDGMENTS.....	iv
TABLE OF CONTENTS	v
LIST OF FIGURES.....	vii
LIST OF TABLES	ix
 CHAPTER	
I INTRODUCTION.....	1
II BACKGROUND.....	3
1.2 Ventricular Recovery	6
III AIM I PROBLEM STATEMENT	8
IV AIM I METHODS AND DESIGN	11
4.1 Shape of Framework	12
4.2 Wire Selection	15
4.3 Adjustability of Device	16
V AIM I MANUFACTURING AND PART DESCRIPTION.....	19
5.1 Top Plate	19
5.2 Bottom Plate	21
5.3 Cylinder	23
5.4 Cylinder Plug.....	24
5.5 Threaded Rod Heads	25
5.6 Non-machined Parts	26
5.7 Assembly of Framework	27
VI AIM I DESIGN EVALUATION	29
VII AIM I FUTURE CONSIDERATIONS.....	31

CHAPTER	Page
VIII AIM II PROBLEM STATEMENT	33
IX AIM II METHODS AND DESIGN.....	35
9.1 Methods and Design Progression of Welds	38
9.2 Chamber Shape Progression.....	42
9.3 Inflation Points	46
X AIM II MANUFACTURING PROCESS	47
XI AIM II MODELING	50
XII AIM II DEVICE EVALUATION.....	53
XIII AIM II FUTURE CONSIDERATIONS	55
XIV SUMMARY	56
REFERENCES.....	57
APPENDIX A	58
APPENDIX B	70
VITA	73

LIST OF FIGURES

FIGURE	Page
1 Anstadt cup.....	5
2 "Ball in Well" analogy explaining instability.....	6
3 Schematic of DCCD framework	9
4 Picture taken of testing apparatus.....	13
5 Comparison of .032” diameter spring steel wires to profile of normal ovine heart	14
6 Tightening mechanism design.....	17
7 Top plate isometric view	20
8 Bottom plate isometric view	21
9 Cylinder isometric view	23
10 Cylinder plug isometric view	24
11 Threaded rod head isometric view	25
12 Complete assembly isometric view.....	28
13 Newly designed tightening mechanism.....	31
14 Profile view of membrane with heart inside to show how the device changes from the apex to the base	36
15 Inner membrane top view.....	37
16 Schematic of wooden framework for the upper portion of the device with nickel-chromium wires attached	39
17 Chambers of membrane	40
18 Crenulations in membrane chambers top view	41

FIGURE		Page
19	Profile view of membrane with heart inside	42
20	Schematic of chambers with curved welds and variable height.....	44
21	Schematic of hydro pump used to pressurize the inner membrane.....	54

LIST OF TABLES

TABLE	Page
1 Spring steel components shown by percentage of weight.....	15
2 Spring steel mechanical and thermal properties.....	15
3 Design specifications for adjustable outer shell.....	30
4 Current/Temperature table for nickel-chromium wire and melting temperature for low density polyethylene.....	39
5 Dimensions of heart used for the constructions of the inner membrane.....	51
6 Inner membrane dimensions based on the dimensions of the heart used to construct the membrane.....	51

CHAPTER I

INTRODUCTION

Congestive heart failure (CHF) is a debilitating disease that affects nearly 5 million Americans and 550,000 new cases are diagnosed each year (AHA, 2003). In congestive heart failure, the heart enlarges and the walls of the heart thin predominantly in the ventricles. This improper growth and remodeling causes the heart to lack the strength to function properly. With the rise of heart problems in America, particularly with millions of Americans suffering from CHF, there has become a need for a device that not only assists the failing heart but also helps the heart grow and remodel back to its normal configuration. Dr. John C. Criscione of Texas A&M University has envisioned such a device that is included in the category of medical devices called direct cardiac compression devices (DCCDs). Dr. Criscione's novel idea is to develop a DCCD that mimics natural strain patterns experienced in vivo. Several studies have shown the importance of mechanical stimuli in cardiovascular development, adaptation, and disease (Taber, 2001; Humphrey, 2002). It has been hypothesized that this novel device will not only aid the heart in pump function but it will also do what no other DCCD currently does, aid in proper growth and remodeling. The primary focus of the graduated student investigator (GSI) will be to develop two key components of the novel DCCD. The first component will be an adjustable outer shell which will enable the device to become smaller as the failing heart returns to normal size. The second component will be an

This thesis follows the style of Journal of Biomechanics.

inflatable inner membrane that applies direct pressure to the outer wall of the heart in a way that promotes physiological stress and strain patterns.

CHAPTER II

BACKGROUND

There are currently 5 million cases of CHF in the United States and that number is increasing in incidence because of the growing age of the population and higher survival rate of first time heart attack victims. There has thus become a greater need for improvements in the treatment of CHF. Currently, patients suffering from CHF not only experience a diminished quality of life but there is also little chance for recovery. For people with class IV heart failure, heart transplantation is often their only chance for survival. However, the availability of donor hearts each year is approximately 2,100 in the United States (AHA, 2003), which is substantially less than needed.

There are currently several mechanical devices that assist failing hearts in blood delivery, yet they do not aid the heart in a physiological manner. Such devices fall into a number of categories including: intravascular ventricular assist devices (IVADs), counter pulsation assist devices (CPADs), and direct cardiac compression devices (DCCDs). In the first of these categories, IVADs assist in blood delivery by directly contacting the blood. With most IVADs, blood is diverted from the heart in a bypass manner, pressurized, and returned to the arteries. Blood delivery aid from IVADs is basically limitless; however, the more assistance IVADs offer the less work the heart must perform. Diminishing the work that the heart must perform is a key objective of cardiac assist devices; however, IVADs have no direct control of cardiac motion and thus cannot aid in applying physiological strain patterns to the heart. The second category of cardiac assist devices is CPADs. CPADs assist the heart by deflating during

systole and inflating during diastole, which decreases mean systolic pressure while increasing mean diastolic pressure. The aid provided by CPADs decreases the work done by the heart during ejection for a particular mean arterial pressure. There are limits to the amount of help CPADs can provide because the heart still does much of the work and systolic pressure cannot be made too low. Like IVADs, CPADs have no direct control of cardiac motion and thus cannot aid in applying physiological strain patterns to the heart. The final category of cardiac assist devices, which includes the current novel device, is DCCDs. DCCDs work by pushing on the outside of the heart during systole and relaxing during diastole. By increasing the extra-ventricular pressure, DCCDs unload the heart enabling it to pump with less work. DCCDs are thought to be the most promising of cardiac assist devices in aiding pump function. There are several DCCDs that have been developed and are being developed, but most have the same problem; they invert the curvature of the heart. The Anstadt cup, seen in Fig. 1 is a perfect example of this type of DCCD.

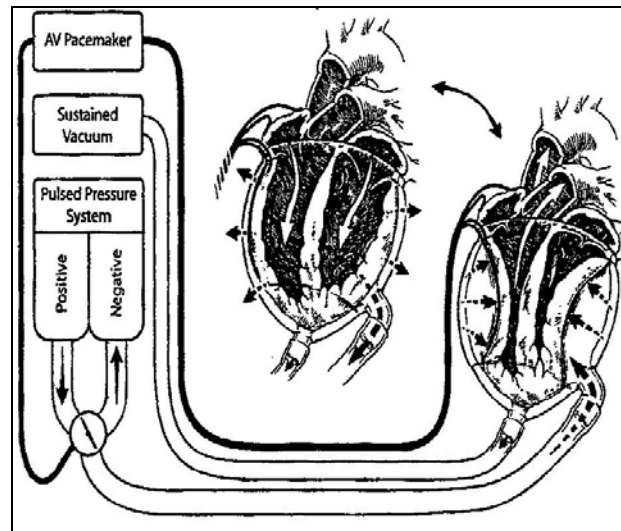

Fig. 1: Anstadt cup. As scanned from Anstadt et al. (2002). Note the curvature inversion when the device is inflated.

The Anstadt cup works by inflating a membrane between the epicardial surface and a rigid outer shell. The inflating of the Anstadt cup increases the extra-ventricular pressure during systole, aiding the heart in pump function. However, the Anstadt cup, like other DCCDs, does not apply uniform compression. Instead the Anstadt cup pulls in the apex to base direction and pushes on the equator, which does not promote a physiological environment. Current IVADs, CPADs, and DCCDs do aid in blood delivery and some in pump function, but they all inadvertently weaken the heart further. Consequently, the heart becomes more reliant on the device instead of the device helping the heart to become self reliant.

1.2 Ventricular Recovery

Obviously, aid in blood delivery and pump function are key objectives for the novel DCCD, but ventricular recovery is just as important of an objective. Ventricular recovery is essentially the re-growth of a healthy heart and is quite possible. Drug therapy has shown to be very promising in improving quality of life and survival for patients with CHF. However, when using drug therapy alone, too many patients still reach end stage heart failure. Drug therapy combined with mechanical assistance has shown to be even more promising (Terracciano et al., 2003). It is hypothesized that this novel DCCD combined with drug therapy and exercise will lead to ventricular recovery in as little as three months time. The theoretical framework behind this hypothesis can be explained using a “Ball in a Well” analogy seen in Fig. 2. First realize that growth and remodeling in CHF is unstable in that it is an unchecked, unidirectional progression in which the heart gets bigger, thinner, and worse at pumping as the disease progresses.

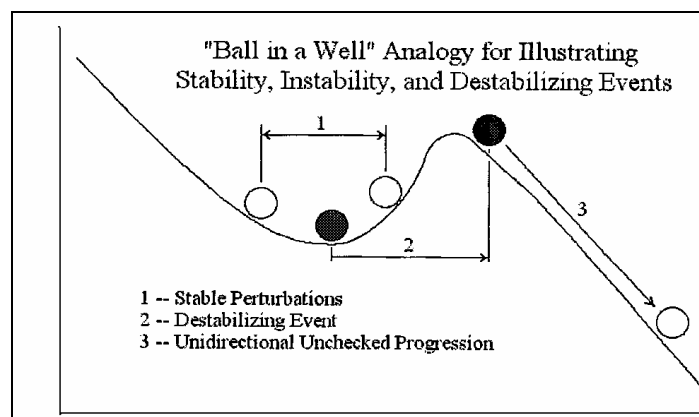

Fig 2: "Ball in Well" analogy explaining instability.

There is however a stable region in which myocytes experience strain patterns within the normal physiological bounds and ventricular recovery can ensue. Without the aid of mechanical stimuli, the heart is unable to stay within the stable region, or the well. With the aid of mechanical stimuli, the heart is off-loaded and the strain patterns return within the physiological bounds. Myocytes can then begin to grow and remodel normally, leading to ventricular recovery.

CHAPTER III

AIM I PROBLEM STATEMENT

In order to achieve all the goals of this novel DCCD, it is important to break down the entire device into several parts and focus on each part individually. It was the goal of the GSI to focus on the design and construction of two such parts of the entire device, an adjustable outer framework for the shell of the device and an inflatable inner membrane that applies uniform pressure to the heart.

The first objective was to design and construct an adjustable outer framework for the shell of the device. Fig. 3 shows an example of the proposed framework. As hypothesized, the heart, when unloaded with mechanical stimuli, will begin to grow and remodel in a normal physiological manner. This proper growth and remodeling will decrease the size of the heart, thicken the walls of the heart, and promote pump function. Since the size of the heart will be decreasing as ventricular recovery progresses, it is necessary for the device to be easily adjustable to accommodate the size changes in the heart.

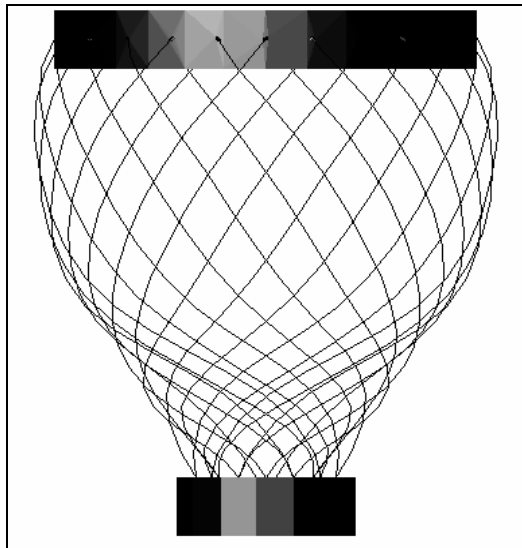

Fig. 3: Schematic of DCCD framework.

If the device were not adjustable, every time the heart decreased in size a new device would have to be implanted, which from a surgical standpoint is unrealistic. The adjustability of the DCCD must also be performed by a minimally invasive procedure to reduce post-operative care or surgery. The framework must be sturdy enough to not yield when the inner membrane is pressurized. Since the GSI is designing an alpha prototype, biocompatibility of materials will not be taken into account. Biocompatibility of materials will be essential in later models of the device that will be implanted, but for the alpha prototype, functionality is the primary concern. To overview, the primary goals of Aim I in the design and construction of the framework for the DCCD are

- The framework must be easily adjustable to minimize post-operative surgeries.
- The framework is able to increase to the size of a failing heart and decrease to the size of a normal heart, while maintaining proper shape.

- The framework is able to withstand, without plastic deformation, the forces experienced when the inner membrane is inflated.

CHAPTER IV

AIM I METHODS AND DESIGN

Testing of prototype models of the DCCD will be conducted with adult ovine post-infarction CHF models. Therefore the alpha prototype components that the GSI constructed were sized for adult ovine hearts. Dr. Criscione's laboratory contains several ovine hearts which were used to obtain dimensions for modeling. Once an appropriate model of an adult ovine heart had been constructed, the GSI used the model in the manufacturing of the components previously discussed.

In the design of the framework, the two most important aspects considered were how to get the appropriate shape for the framework and how to best construct the adjustability of the device. Twenty-four thin wires were placed in a helical fashion to mimic the curvature of the heart. The cage of wires would fit in between the two Plexiglas pieces and act as a mesh surrounding the heart. The cage of wires is what will be changing shape when the tightening mechanism is adjusted. The material for this part of the device would have to be flexible enough to allow stretch and constant shape change but sturdy enough not to plastically deform under the extended amounts of stress and strain that would be applied to it. The shape that the framework would take on depended primarily on the material properties of the wires used and the departure angles of the wires, circumferentially and axially. A testing apparatus was constructed in which several wires of different material compositions, thicknesses, and different departure angles could be examined to find the appropriate combination for the correct shape of the framework.

In the construction of the tightening mechanism several designs were considered. Ultimately, the tightening mechanism had to be easily adjustable and uniformly decrease the size of the framework. The shape design and tightening mechanism will be discussed further in the following sections.

4.1 Shape of Framework

The testing apparatus was constructed of two polyvinylchloride (PVC) pipes and a Plexiglas plate that held the two pipes together. The upper pipe was constructed to have the same diameter as the top plate of the device and the lower pipe was constructed to have the same diameter as the bottom plate. Holes were drilled in the upper pipe at different circumferential and axial departure angles. The circumferential angles, θ , were drilled at 0, 15, 30, and 45 degrees around the testing apparatus. The axial angles, ϕ , were also drilled at 0, 15, 30, and 45 degrees as the holes went down the testing apparatus. Fig. 4 shows a picture of the testing apparatus used to examine the wire departure angles.

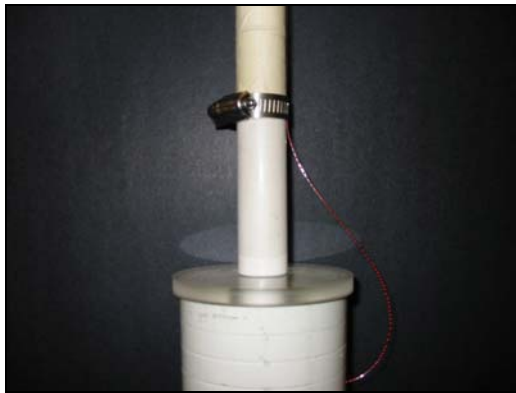

Fig. 4: Picture taken of testing apparatus. Apparatus is upside down.

Therefore a combination of each circumferential and axial departure angles could be examined. A wire was then placed in the 0° - θ , 0° - ϕ hole and attached to the lower part of the testing apparatus at the distance desired for the height of the framework, approximately five inches. The procedure was then repeated for each of the different axial departure angles with the wire length and distance held constant. For this part of the test, the circumferential angle was held constant at 0° , so the true shape profile could be examined. At each axial angle a picture was taken and analyzed using a program called ImageJ. ImageJ allowed for points along the wires to be placed in a text file in the form of an x-y plane. Once the x and y positions were calculated for the pictures, the plots were compared to actual measurements taken from an adult ovine heart. The entire procedure was repeated for the same type of wire but at a different wire length. The wire lengths used were 6.5 inches and 7.5 inches. These lengths were selected by trial and error. The test was conducted for two different types of wire at two different thicknesses. Fig. 5 shows the results from the wire that was selected for the framework, spring steel at .032" diameter. Fig. 5 shows that the wire with a departure angle of 15° has the best

profile (most like the normal ovine heart). The two wire lengths were chosen to show how the profile changes as the length is increased and decreased. If the wire length was shortened even further it would become more like the normal ovine profile.

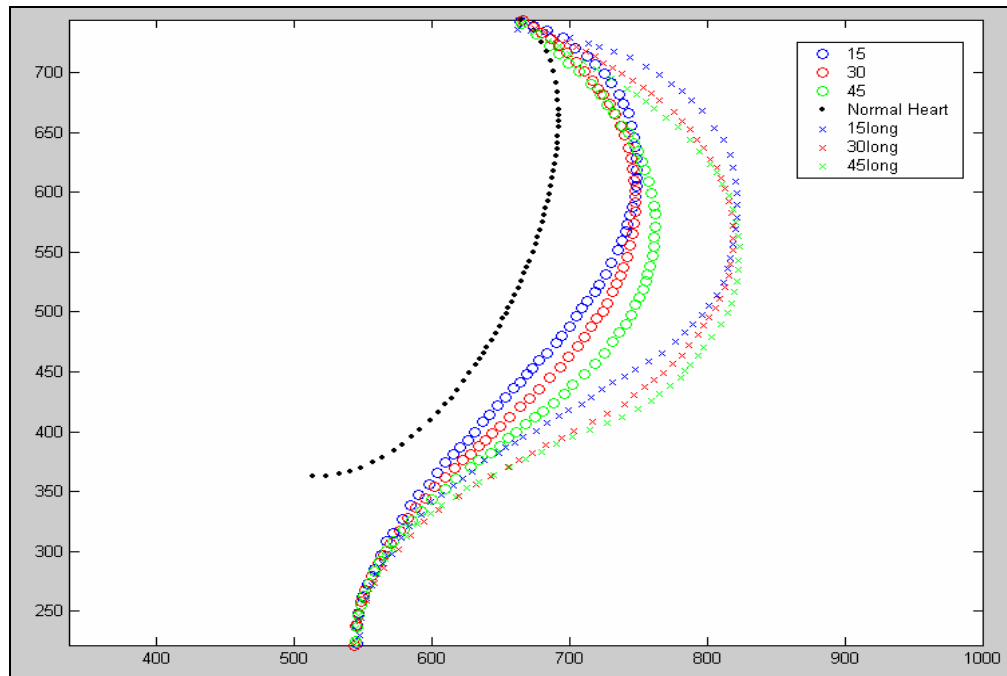

Fig. 5: Comparison of .032" diameter spring steel wires to profile of normal ovine heart.

The circumferential departure angle was selected by a visual and theoretical comparison. It was decided that the more cross-linking provided by the framework the better, because the cross-linking of the wires would mechanically strengthen the framework. Therefore, the maximum circumferential departure angle of 45° was selected for the manufacturing of the framework. An angle greater than 45° was avoided because of the increasing difficulty in manufacturing. The circumferential departure angle did not change the shape profile because the profile could be adjusted by the wire length.

4.2 Wire Selection

The wires that will make up the wire mesh of the device are the most important component in the entire device. The wires will undergo considerable stress and strain as the shape of the mesh changes with manual adjustment of the tightening mechanism. After investigation of available materials and on the suggestion of Dr. Criscione, the GSI selected spring steel (ASTM A228) as an appropriate material for the wire mesh. Tables 1 and 2 give an overview of the physical and chemical properties of spring steel wires (MatWeb, 2003).

Table 1
Spring steel components shown by percentage of weight.

Component of Spring Steel	Wt. %
C	0.7 - 1
Fe	Min 98.4
Mn	0.2 - 0.6

Table 2
Spring steel mechanical and thermal properties.

Mechanical Properties	English	Comments
Hardness, Rockwell C	41 - 60	
Tensile Strength, Yield	231000 - 399000 psi	Varies within the given range according to wire diameter.
Modulus of Elasticity	30500 ksi	
Poisson's Ratio	0.313	Calculated
Shear Modulus	11600 ksi	
Maximum Service Temperature, Air	248 °F	

Table 2 shows the physical properties that the steel wires possess. The chart shows that the steel wires possess a very high tensile strength with uniform mechanical properties. These characteristics show that spring steel is well-suited for projects or applications that require good fatigue properties and can handle high stresses. These wires are able to deform, without plastic deformation, and still maintain their strength and rigidity. It is recommended that these wires be used for service temperatures below 121°C (248°F). These characteristics exceed the requirements that are needed for the steel wires within the device, which is why spring steel was selected.

The wire thickness was determined primarily by availability and desired physical properties. For the framework it was desired that the wires be thick enough to handle the stresses and strains applied by the pressurizing of the device but as thin as possible to minimize the size of the device. A thickness of .032” diameter was chosen based on availability and these physical properties.

4.3 Adjustability of Device

As previously mentioned, the framework of the device needed to be adjustable to compensate for the decreasing size of the heart. The adjustability needed to be easily performed by a minimally invasive post operative surgery and the mechanism by which the framework was adjusted needed to be sturdy enough to handle the stresses and strains experienced during the manual adjustment of the device. Several designs of the tightening mechanism were considered for the framework.

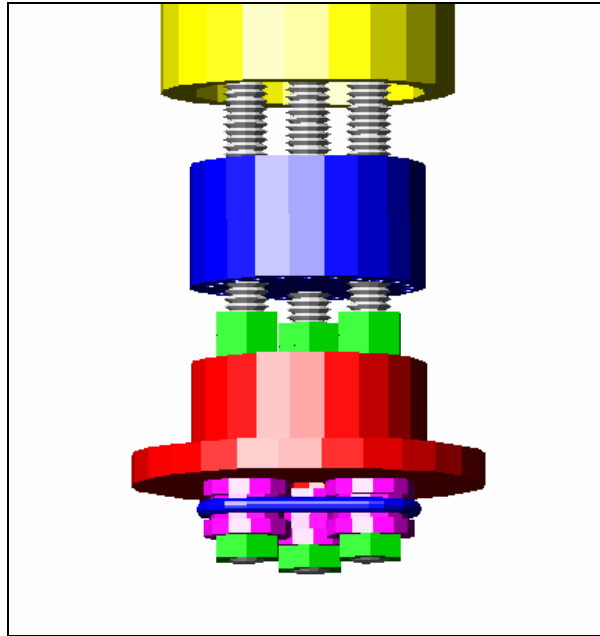

Fig. 6: Tightening mechanism design.

Ultimately, the design chosen consisted of seven key components seen in Fig. 6, a bottom plate (blue), three threaded rods (grey), a cylinder (yellow), a cylinder plug (red), threaded rod heads (magenta), nine nuts (green), and a rubber o-ring (blue). The adjustability of the tightening mechanism works by having the wires attach to the bottom plate and having the bottom plate move up and down the three threaded rods. As the bottom plate moves along the threaded rods the wires are drawn into the cylinder which restricts the expansion of the rods. The movement of the bottom plate results from turning the threaded rods with a hex nut attachment. To stabilize the tightening mechanism three rods were used to move the bottom plate up and down the cylinder. Three rods were selected because they created a plane in which the bottom plate would move uniformly. Using three rods also meant that all three of the rods had to turn in

unison. A rubber o-ring served as the tool that turned the rods in unison. As one rod turned, friction created between the rubber o-ring and the threaded rod heads turned the other two rods in an equal amount. Having the adjustability depend on the rotation of only one of the rods simplified the tightening mechanism. Once implanted, the device could thus be expanded or contracted by a laparoscopic surgery, which is desired. The design of the tightening mechanism therefore meets the two primary concerns, it being easily adjustable and it being sturdy.

CHAPTER V

AIM I MANUFACTURING AND PART DESCRIPTION

5.1 Top Plate

The top plate, seen in Fig. 7, was manufactured out of a solid sheet of Plexiglas and has a total radius of 1.875" and a height of 1". The purpose of the plate is to hold the spring steel wires that originated from the bottom plate in place while the tightening mechanism contours the helically planned shape. The top part of the plate is set back 0.1" from the bottom part to aid in the machining of the part. There is a manufactured threaded hole with a ¼ -20 thread through the center of the plate which allows for the placement of a threaded rod. The rod keeps the device stable when it is presented or transported. The hole does not serve any purpose in the function of the device within the human body. In fact, if this device were to be implanted, the entire inside portion of the top plate would be removed because the top plate would be secured to the valve plane. However, since this device is an alpha prototype and will not be installed there was no need to remove this portion. The thread hole was first bored with a #18 drill bit and then threaded with a ¼-20 tap. Throughout the outer rim of the plate on the bottom portion, there are 24 holes with a .036" diameter all located equidistant from the center of the part.

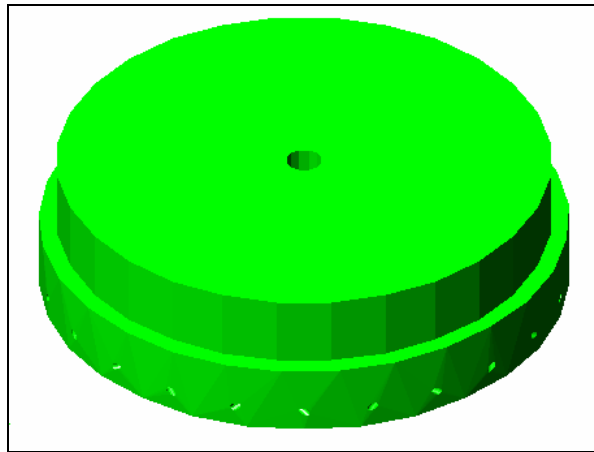

Fig. 7: Top plate isometric view.

These 24 holes hold the helically placed spring steel wires that run along the outer side of the device. The GSI decided that 24 wires for the framework would maximize the cross-linking without the device being too cluttered. Each hole is burrowed within the Plexiglas at a circumferential angle of 45° and an inclination angle of 15° as previously discussed. For the wires to cross, it was necessary for half of the circumferential departure angles to exit at 45° clockwise and for the other half to exit at 45° counterclockwise. The top plate was constructed by first cutting a round piece, approximately 4" in diameter, from a one inch thick sheet of Plexiglas. The round piece was then placed in the lathe and machined to the desired diameter of 3.75". The lathe allowed for the part to be machined to a more precise diameter and allowed for the edges to be smoothed. The .1" set back previously discussed was added during this process to aid in the machining of the part. Next, the top plate was placed in a chuck that allowed inclination angles as well as circumferential rotation so the departure holes and center

threaded hole could be drilled. A mill with a digital position meter was used to bore the departure holes at the specific angles desired.

5.2 Bottom Plate

The bottom plate, seen in Fig. 8, serves as the attachment point of the wires to the bottom part of the device. The bottom plate moves up and down three threaded rods either drawing the wires into the cylinder to contract the device or push the wires out of the cylinder to expand the device. The bottom plate was constructed by first using the hole-saw to cut a one inch diameter, four inch long Plexiglas cylinder. Using the lathe, the outside edges were smoothed and a center hole with a $\frac{1}{4}$ -20 thread was drilled.

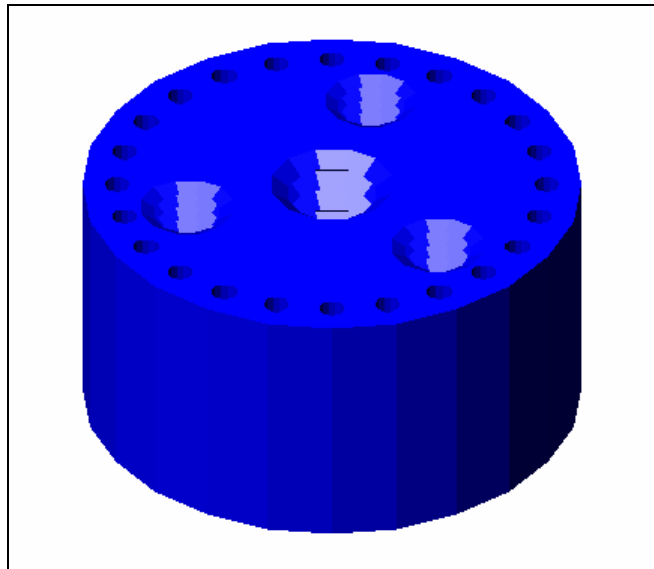

Fig. 8: Bottom plate isometric view.

The center threaded hole, like in the top plate, was used to stabilize the device during transportation and attach of the wires. A #18 bit was used to drill the hole and a 1/4-20 tap was used to thread it. Next, the three threaded holes for the rod had to be cut. The cylinder was moved into the vice under the mill but left at an inclination angle of zero degrees. The centering bit was used to indent holes at the corners of an equilateral triangle, 0.3” away from the center of the cylinder and 120° apart. Then, a #29 bit was used to bore the holes in the cylinder, and an 8-32 tap was used to thread them. To thread the three holes, the first few threads were done on the mill but the rest of the thread was finished by hand. With the cylinder already in the vice, the cylinder was positioned such that the drill bit was 0.43” away from the center of the cylinder to bore the twenty-four holes for the wires. The twenty-four holes were drilled with a #55 drill bit at every 15° around the outer edge of the bottom plate. Finally, the cylinder was placed in the lathe again and cut at a height of .5”.

5.3 Cylinder

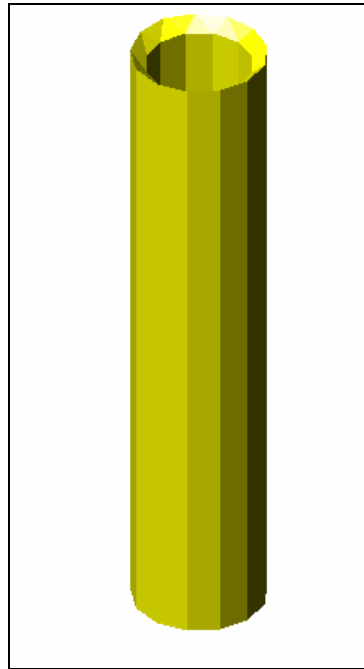

Fig. 9: Cylinder isometric view.

The cylinder, seen in Fig. 9, served to restrict the expansion of the wires as the bottom plate pulls the wires down the cylinder. The cylinder was cut from a 1.25" outer diameter piece of PVC pipe at a length of 6" using the lathe. With a face-off tool, the inner diameter was smoothed and cut at an angle of 45° along the top edge of the cylinder. The angle of 45° was added to help the wires draw smoothly into the cylinder. The length of 6" was much larger than what is needed, but for this alpha prototype it was desired to examine the shape of the framework over a larger scale than what would be typically needed.

5.4 Cylinder Plug

The cylinder plug, seen in Fig. 10, served to keep the threaded rods in position. So, as the rods turn the bottom plate moves up and down the cylinder and not the threaded rods. The plug was cut from a piece of aluminum to a height of 0.5”.

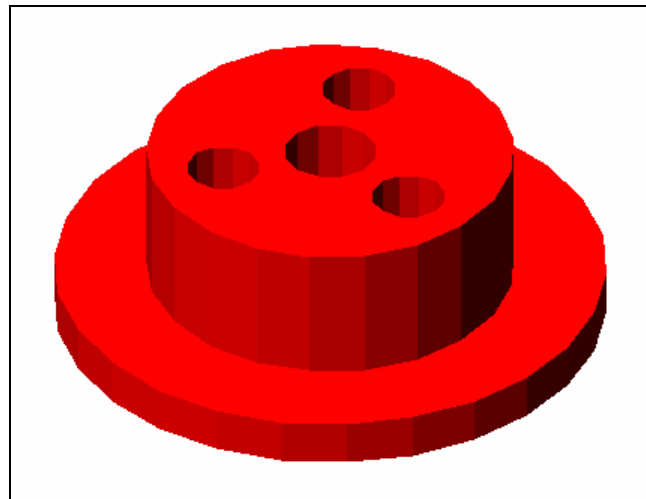

Fig. 10: Cylinder plug isometric view.

The lathe was used to smooth the plug and make an indentation so that the plug was two-tiered with one tier diameter of 1” and the other tier diameter of 1.5”. The plug needed to have a center hole and three holes for the threaded rods, but none of its holes needed to be threaded. The threaded rods could therefore turn inside the cylinder plug without the plug or the rods moving up or down. The lathe was used to cut the center hole, with the same process described in previous parts manufactured. The plug, with a center hole, was then inserted into a vice and a drill press was used to bore the three holes for the threaded rods to slide through using a #19 bit. Like in the bottom plate the

holes were drill .3” from the center at 120° apart so the two parts would align when the threaded rods were inserted.

5.5 Threaded Rod Heads

The threaded rod head, seen in Fig. 11, served to act as the mechanism by which all the threaded rods turned in unison. The heads needed to be threaded to fit onto the rods, with slots of the appropriate size to hold the o-ring snugly. The three heads were cut from a long brass cylinder with a 0.375” diameter. The cylinder was centered in the lathe and the edges were smoothed to make the cross section more circular.

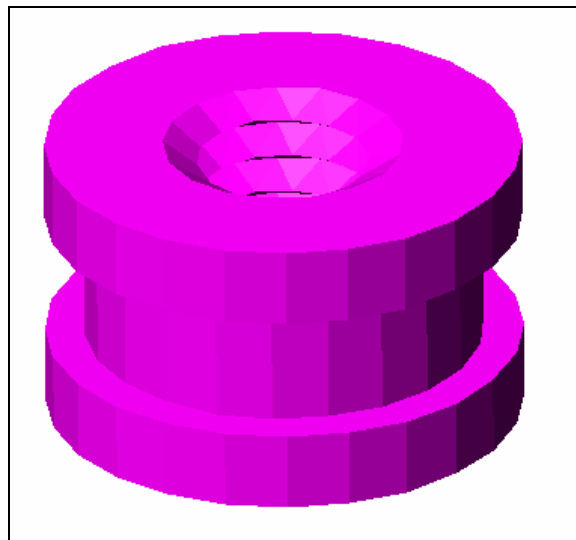

Fig. 11: Threaded rod head isometric view.

The center of the brass rod was threaded using an 8-32 tap in the same process as previously discussed. Next, smooth grooves were made at 0.03” at intervals of .4” along

the length of the cylinder. These indentions were used to guide the rubber o-ring as the threaded rods turned. Lastly, the cylinder was cut off at the appropriate lengths in order to produce three identical, slotted heads. The heads were each reinserted into the lathe to smooth the rough edges and then were manually rethreaded with the 8-32 tap.

5.6 Non-machined Parts

As previously discussed three threaded were used to move the bottom plate up and down the cylinder. The rods used were #8-32 and cut at 6.5" each. Nine 8-32 nuts were used to anchor the bottom of the threaded rods to the cylinder plug. On each of the three threaded rods, a threaded rod head and nut were tightened against each other to hold them in place. On the opposite side of the cylinder plug, two nuts were tightened against each other to hold them in place. The combination of two nuts was placed so that the threaded rods could easily rotate but not move up and down. The wires used to construct the framework were made of spring steel and had a diameter of 0.032". The wires that circumvent the device in a right-hand circumferential angle have a length of 13.5". The wires that circumvent the device in the opposite direction have a length of 13.19". The lengths were made different due to the placement of the wires at the site of attachment. One wire butts into the other wire; therefore, the second wire must be shorter since it does not embed as far into the top plate. The final non-machined part was a #42 o-ring with an inner diameter of 0.5", an outer diameter of 0.6875" and a thickness of 0.09375". The rubber o-ring was stretched around the threaded rod heads, so that when

one rod turned, the other two rods would turn due to the friction created between the o-ring and the threaded rod heads.

5.7 Assembly of Framework

First, the heads of the threaded rods were screwed onto one end of each of the threaded rods and followed by one of the 8-32 nuts to secure the placement of the head. Next, each of the rods was inserted into the bottom side of the cylinder plug and two of the 8-32 nuts were screwed onto the opposite side of the threaded rods. The nuts were tightened against each close to the top part of the cylinder plug to hold the threaded rods in position. The nuts were placed close enough to the cylinder plug to prevent the rods from moving up and down but far enough away to allow the rods to rotate. After the assembly of the rods with the cylinder plug, the $\frac{1}{4}$ -20 threaded rod was screwed through the center hole of the top plate on one end and through the center hole of the bottom plate on the opposite end. The $\frac{1}{4}$ -20 threaded rod was used to hold the two plates in position while the wires were attached. The wires, one by one, were then attached to the top plate first and then to the bottom plate. The wires were secured to each plate with super glue. Once the wires were secured, the framework could be completely assembled. For the final assembly the cylinder was placed over the three 8-32 threaded rods and firmly placed onto the cylinder plug. Next, each of the 8-32 threaded rods was manually started into the bottom plate. Once all three rods had been started and were on the same thread, the rubber o-ring was pulled over the threaded rod heads into the slotted area. Now as one of the rods turned, the other two rods turned in unison and the framework

could be drawn into the cylinder to the desired shape. The $\frac{1}{4}$ -20 threaded rod could then be removed and the assembly was complete. An isometric view of the complete assembly can be seen in Fig. 12.

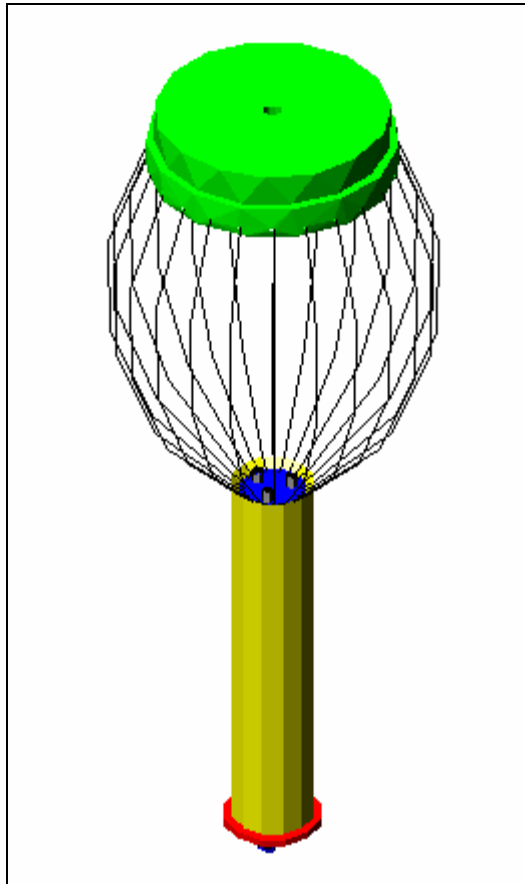

Fig. 12: Complete assembly isometric view.

CHAPTER VI

AIM I DESIGN EVALUATION

All of the device specifications were met during the design of the device. These specifications were based on dimensions of manufactured parts and included the top ring diameter of 3.5”, the shape of the wires being that of the shape of a heart, the tightening mechanism consisting of three threaded rods, and the device being able to be adjusted using a surgical scope. The device specifications that had to be tested were that the device could be enlarged to a maximum diameter equal to that of a hypertrophic sheep heart (roughly 5.9” in diameter) and that the device could be reduced to the size of a normal sheep heart (roughly 4.5” in diameter.) Both device specifications were tested and met; the device is reducible to the size of a normal sheep heart and extendable to the size of a hypertrophic sheep heart. The only other specification that was previously listed was that the device be able to withstand pressures necessary to compress the heart, approximately 9kPa. It was decided by the GSI that an actual test of the specification would be premature in the alpha prototype, since parts were constructed from materials that would never be encountered *in vivo*. Table 3 seen below shows a list of the proposed specifications and the actual device specifications.

Table 3
Design specifications for adjustable outer shell.

Specification	Testing Method	Specification Met?
Max size bigger than hypertrophic heart—5.9” diameter	Measure with ruler	Yes
Plexiglas ring 3.5” diameter	Measure with ruler	Yes
Reducible	Visual inspection	Yes
Min size—4.5” diameter	Measure with ruler	Yes
Must fit to shape of heart	Compared using ImageJ	Yes
Three threaded rods turn simultaneously	Visual and trial testing	Yes

Overall the design of the device was a success. The wires of the device are shaped like that of a heart and the device is able to be reduced to the size of a normal sheep heart and is extendable to the size of a hypertrophic sheep heart. The device is also adjustable using a surgical scope so that invasive postoperative surgery could be minimized.

CHAPTER VII

AIM I FUTURE CONSIDERATIONS

The main concern with the alpha prototype framework was the size. Having the wires drawn into a cylinder in the bottom part of the device makes this part of the design too bulky. The area below the heart is very limited for space; therefore, it would be beneficial for the bottom part of the device to take up as little space as possible. The GSI along with Dr. Criscione came up with a new design for the tightening mechanism that does not require the wires to be drawn into a cylinder. The new tightening mechanism design can be seen in Fig. 13. The design consists of two interlocking bottom plates that can be rotated in opposite directions. When the plates are rotated in opposite directions the wires will further cross-link and reduce the size of the framework. The idea would be to have a spring lock the two plates together with little indentions between the two plates, located at certain degree interval.

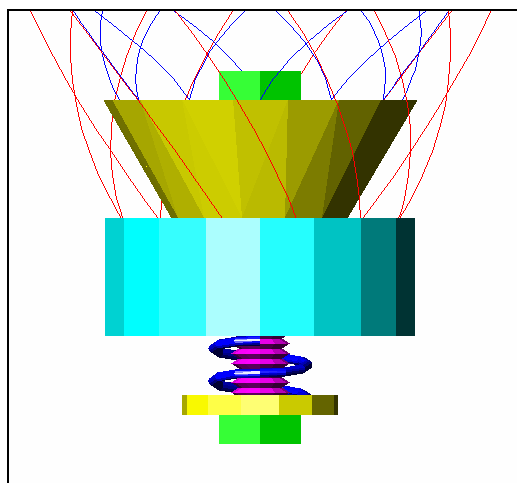

Fig. 13: Newly designed tightening mechanism.

The bottom plate could then be pulled away from the top plate, compressing the spring, and rotated to the next interval. Once at the desired interval the bottom plate could be released and the spring would hold it in place. This type of design for the tightening mechanism would drastically reduce the size of the framework and therefore reduce the amount of space needed in the chest cavity. Another problem encountered with the current design of the framework dealt with slipping occurring between the o-ring and the threaded rod heads. This slipping resulted in the rods not all turning in unison. The problem of slipping could be rectified by the new design for the tightening mechanism. Therefore, the new design would not only take up less space but it would also fix the problem of having three threaded rods turn in unison.

CHAPTER VIII

AIM II PROBLEM STATEMENT

The second objective of the GSI was to design and construct an inflatable inner membrane for the novel DCCD. The membrane will be pressurized with air in order to apply direct mechanical stimulus to the epicardial surface. The initial design characteristics for the inner membrane were that it be constructed of a plastic, probably polyethylene, and consist of several small chambers that when inflated took on the shape of the heart. The membrane would also be divided into two parts, one part for the right heart and one part for the left heart. The division allows for the right and left ventricles of the heart to be pressurized at different amounts. It was the goal of the GSI to construct the inner membrane so that when inflated it took on the shape of the heart it surrounded. Having the inner membrane take on the shape of the heart is essential for the device to be able to apply uniform compression to the heart. Unlike other DCCDs, this novel device would not invert the curvature of the heart, but rather promote a physiological strain pattern. Like the first objective, long term biocompatibility of materials was not taken into account at this stage of development. Functionality of the device was the primary concern. To overview, the primary goals of the second objective in the design and construction of the inner membrane for the DCCD were

- The membrane applies uniform pressure to the heart instead of inverting the curvature.
- The membrane withstands the pressure necessary to unload the heart.

- The membrane is able to accommodate, in size, a failing heart as well as a healthy heart.

CHAPTER IX

AIM II METHODS AND DESIGN

The design and construction of the inner membrane began after the framework had been completed. The inner membrane was constructed of polyethylene, because of its availability, strength, and variability in thickness. Like in Aim I, an adult ovine model was used to approximate the dimensions for the membrane because later prototypes of the device would be implanted in adult sheep with congestive heart failure. Initially, the design of the DCCD consisted of an outer shell with the inner membrane attached inside of this shell. As the project moved along, Dr. Criscione and the GSI found that it would be very beneficial if the inner membrane could also be a stand alone device. That is, the DCCD would not have an outer shell but could have one if needed. The desire to omit the outer shell came from suggestions that Dr. Criscione acquired at a conference in which post-operative complications due to sternotomy were discussed. Previously, the novel DCCD would have to be implanted by sternotomy due to its rigid outer shell. Without a rigid outer shell, the device could be deflated and implanted by a subxiphoid incision. This new approach did not change the fabrication of the inner membrane because it could still be incorporated with a rigid outer shell. One design idea was to use two different thicknesses of polyethylene to construct the membrane. Allowing the outer sheet of the membrane to be thicker increased the stability. The thicknesses tested were 2, 4, and 6 mil.

The primary design concern of Aim II was for the inner membrane to mimic the shape of an ovine heart so that a natural strain pattern could be applied to the epicardial

surface. Several designs and methods of construction were considered to accomplish this goal. Ultimately, it was decided that the inner membrane should consist of several chambers that when inflated would conform to the shape of the heart and furthermore unload the heart. The chambers ran from apex to base and were larger at the base than at the apex to help hold the heart in the device. Notice Fig. 14 in which the bottom portion of the device is relatively flat where as the upper portion of the device encloses a portion of the base of the heart.

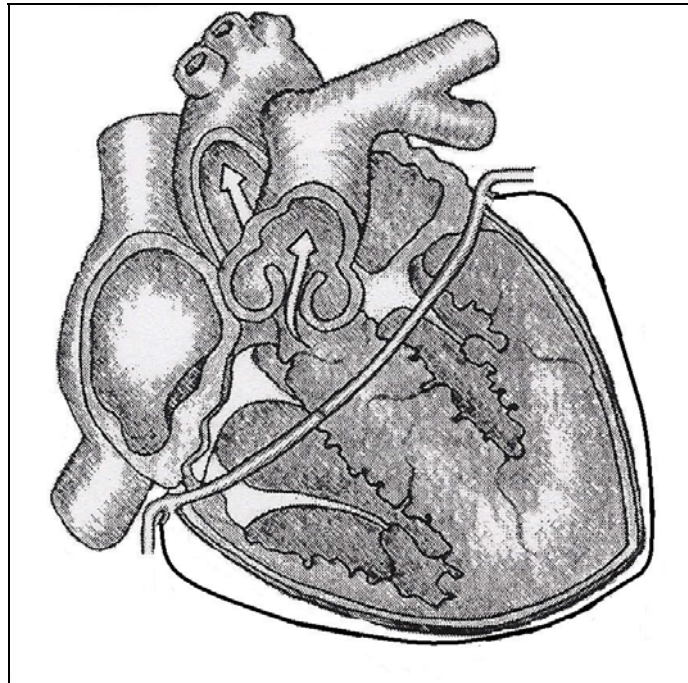

Fig. 14: Profile view of membrane with heart inside to show how the device changes from the apex to the base.

Since ventricular recovery will theoretically take place, the membrane must be able to pressurize not only a failing heart but must also be able to pressurize the heart as it

becomes healthier and smaller. To accomplish this goal, the chambers were created large enough to not only compress an enlarged heart but also a normal sized heart. Enabling the chambers to inflate larger than needed to compress the heart, also allows the chambers to take on the correct shape of the heart.

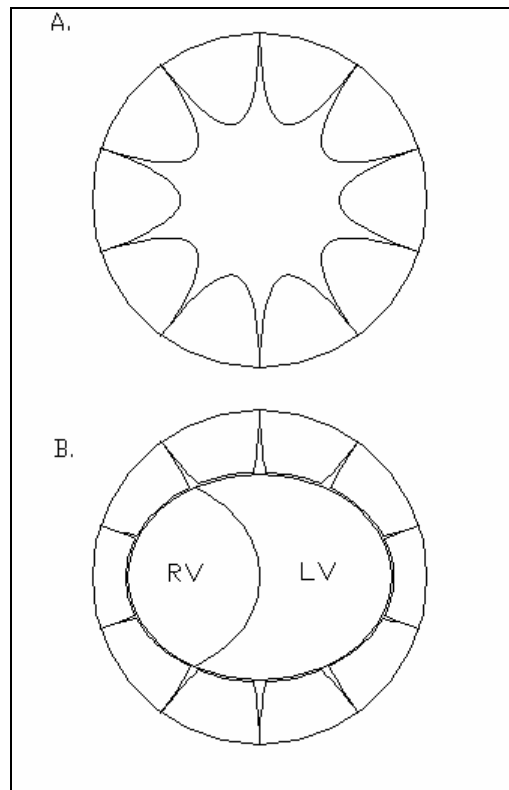

Fig. 15: Inner membrane top view. A. Top view of membrane inflated without heart inside. B. Membrane inflated with heart inside.

Notice Fig. 15, when the device is inflated without a heart inside (Fig. 15A), the chambers take on a spherical shape. However, when the membrane is inflated with the heart inside (Fig. 15B), the chambers take on the shape of the heart creating uniform compression on the epicardial surface.

9.1 Methods and Design Progression of Welds

During the development, several inner membranes were created, starting with the simplest model and becoming more complex as the manufacturing techniques improved as well as design techniques. Initially, the membrane was split into three equal pieces, each containing four chambers. Two-thirds of the pieces would be used for the left heart and the remaining third for the right. The separation of the chambers allowed for the left and right hearts to be pressurized at different amounts. The decision to have twelve chambers came from the idea that the membrane can better take on the shape of the heart with a large number of chambers. However, the more chambers included the harder it is to manufacture. The GSI decided that twelve chambers were optimal in the design of this particular membrane, but more chambers could be included for a larger heart. To manufacture each piece of the membrane a framework was constructed. The framework consisted of a wood base with nickel-chromium wires strung along it. When a current is passed through nickel-chromium wire, it will heat up. Fig. 16 shows a particular pattern that was used in the construction of one third of the membrane.

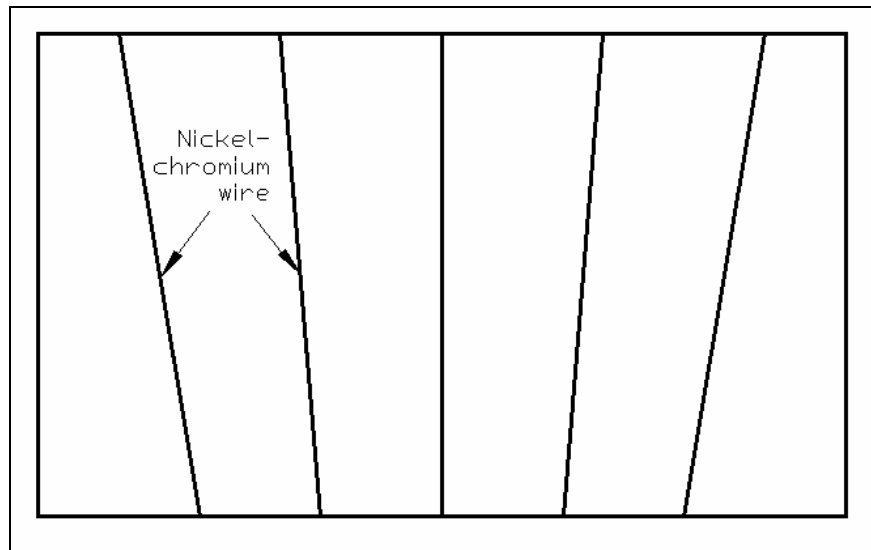

Fig. 16: Schematic of wooden framework for the upper portion of the device with nickel-chromium wires attached.

The idea was to place the nickel-chromium wire in the desired pattern. Then, two of the polyethylene sheets would be pressed against the wire while running a small current through the wire. As the wire heated up it would melt the two polyethylene sheets together. Each of the three pieces could then be welded together in a similar fashion to complete the construction of the membrane. Table 4 shows heating data for nickel-chromium at a diameter of 0.032” and the melting temperature for polyethylene.

Table 4
Current/Temperature table for nickel-chromium wire and melting temperature for low density polyethylene.

Data for 30 AWG (0.032” diameter) Wire				
Degrees Celsius	205	315	427	538
Amperes	3.8	5.1	6.3	7.6
Low Density Polyethylene				
Melting Temperature	110-120° C			

The GSI soon discovered that the nickel-chromium wire got too hot too fast. The polyethylene sheets have a small range of temperatures in which the plastic sheets will melt together or burn completely through. Therefore, the GSI decided to use a different method for the construction of the membrane. The new fabrication technique used brass rods and copper plates that were heated in an oven to the desired melting temperature. This way the melting temperature could be controlled more precisely. The heated rods and plates were then be pressed against the two sheets of polyethylene to melt them together. A wax heat resistant paper was placed between the rods and the plastic as well as under the plastic to keep the plastic from melting to the rods or the underneath surface.

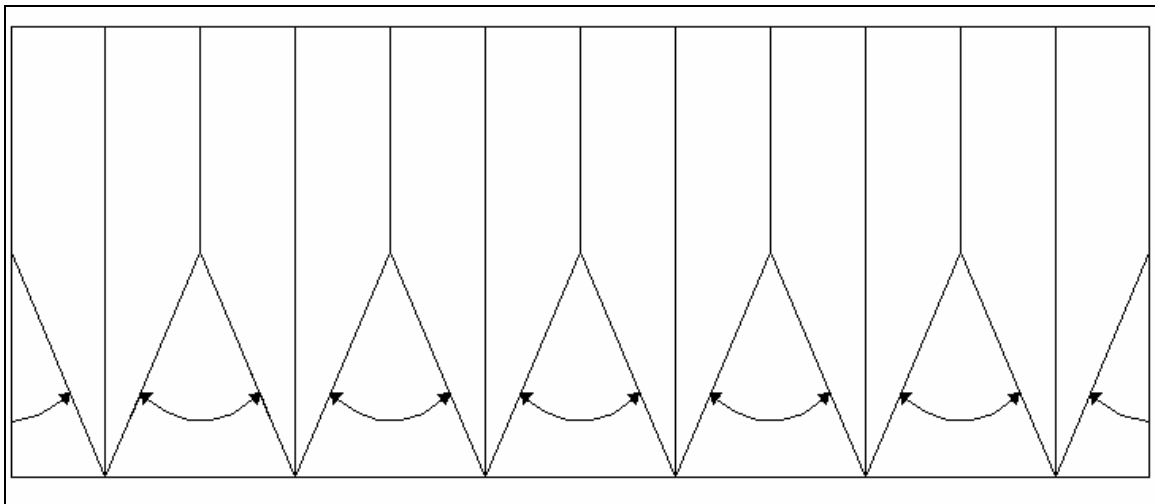

Fig. 17: Chambers of membrane.

Instead of using a framework as with the nickel-chromium wire the chambers were created as columns. As the columns drew nearer to the apex they drew closer together

until they formed a point at the apex. Notice Fig. 17, in which the twelve chambers start wider at the top and then come to a point at the bottom. The arrows between the chambers indicate areas that are removed from the membrane and welded together. This space between the chambers is removed so that the entire membrane comes to a point at the apex. The far left and right sides of the polyethylene sheets were welded together to complete the membrane. In the final configuration the top of the membrane was circular and the bottom as previously discussed came to a point.

In the radial direction the chambers had to have some depth to compress the heart. The depth was added by making the top polyethylene sheet crenulated. Notice Fig. 18 is a top view schematic of the membrane chambers seen in Fig. 17. When the device is inflated the crenulations allow for the membrane to compress the heart as previously discussed. In this Fig. 18 the crenulations represent the inside portion of the membrane and the far right and left ends would be welded together to complete the fabrication.

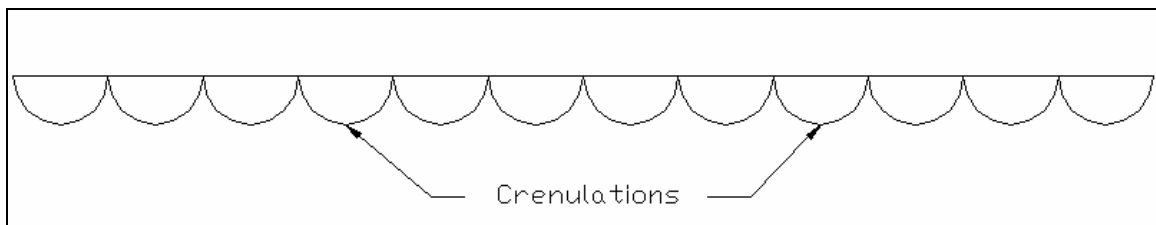

Fig. 18: Crenulations in membrane chambers top view.

9.2 Chamber Shape Progression

As discussed, several membranes were manufactured with each membrane becoming closer to the desired goal. Initially all of the welds were done with straight bars which did not accommodate the natural shape of the heart very well. Fig. 17 shows how the welds were initially constructed which would make the chambers vertical at the top and converge at some angle α terminating at the apex. This abrupt change can best be observed in the profile view of the membrane in Fig. 19.

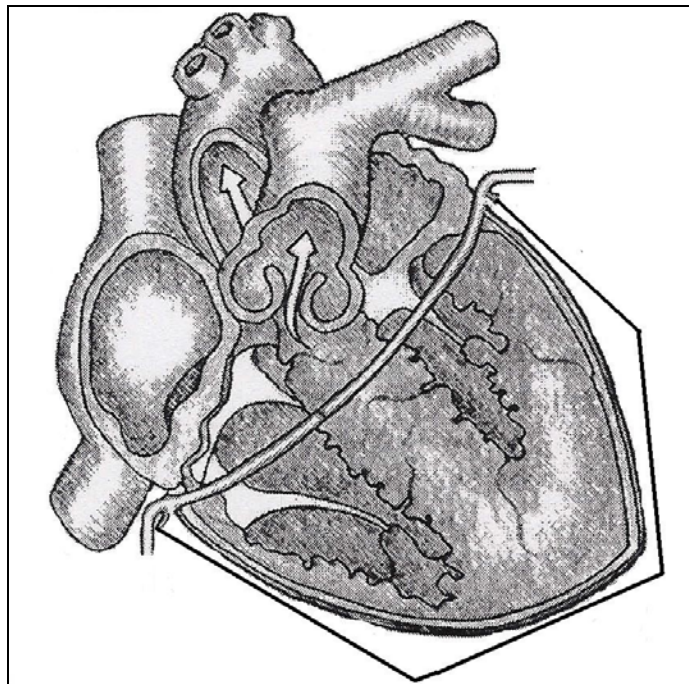

Fig. 19: Profile view of membrane with heart inside.

Obviously the membrane would better conform to the shape of the heart if the profile were curved like the heart. To accomplish this, the GSI decided that the chambers should

gradually get smaller with some curvature instead of abruptly get smaller at some angle alpha. Allowing the chambers to have curved welds meant that some curved bars had to be created to melt the polyethylene sheets together. The GSI used copper bars that were bent to the proper shape to accomplish the need for curved welds .Now, the chambers gradually got smaller as the chambers approached the apex. The curvatures were calculated using AutoCAD®. First it was decided that the start angle of the welds should be 90° since the shape profile is basically vertical at the top. The termination angle was decided by knowing that the twelve chambers terminated at a single point and therefore should each have a termination angle of 30°. Fig. 20 shows the use of curved welds.

Since the membrane is only needed to compress the ventricles the height of the chambers needed to change as the position of the device changed circumferentially. The height of each chamber was taken by the distance between the apex and the valve plane at each radial position. The GSI found that the distance between the apex and the valve plane could be approximated with a cosine curve. Fig. 20 shows how the cosine curve was applied to the top of the membrane to account for the change in height of the device as the position of the device changed in the radial direction.

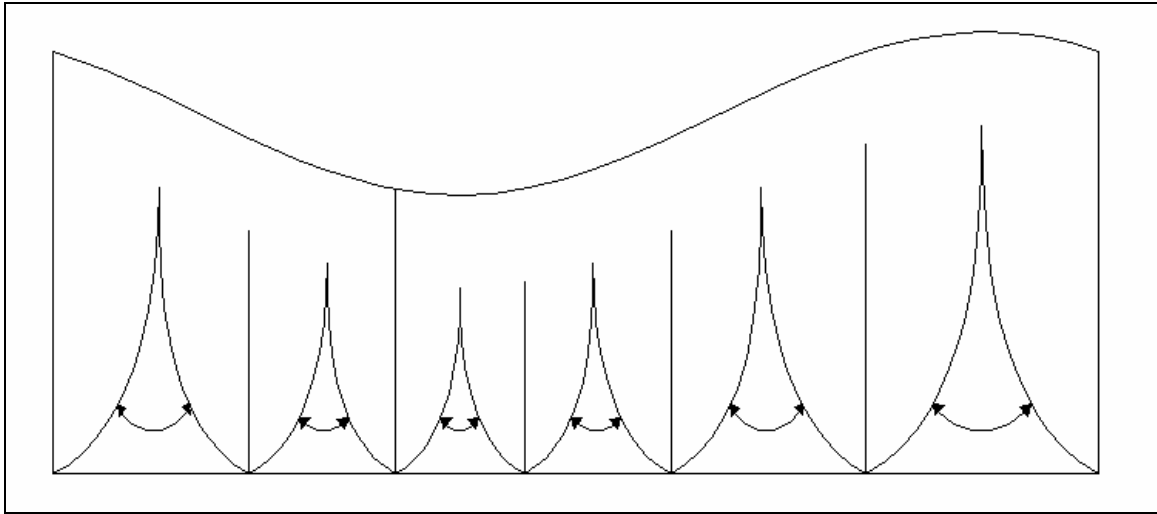

Fig. 20: Schematic of chambers with curved welds and variable height.

Having each chamber have a different height changed the volume of each chamber, and thus altered the air resistance in each chamber. Each chamber needed to have the same air resistance so that when the membrane is inflated it will inflate uniformly. To adjust the resistance in each chamber the chamber widths were altered to give an equal ratio of chamber height to chamber width for each chamber. Since the circumference of the inner membrane was fixed, based on the size of the heart, two equations were used to calculate the chamber widths from the corresponding chamber heights.

$$h_i = h_{\frac{1}{4}L} \left(1 + \alpha \cos \left(2\pi \frac{l_i}{L} \right) \right) \quad \text{Eq. 1}$$

$$l_i = \frac{C}{2} (h_i + h_{i-1}) + l_{i-1} \quad \text{Eq. 2}$$

In these equations $h_{1/4L}$ is the height of the membrane at one-fourth of the entire length, l_i is the chamber width of the i^{th} chamber, L is the entire length, α is a constant, h_i

is the height of the i^{th} chamber, and C is the ratio of the chamber length to the chamber height. The GSI used MATLAB® to write a program to solve for the chamber widths based on the entire length, number of chambers, maximum height and minimum height. The program used to calculate the chamber widths can be found in Appendix B. After the chamber widths had been calculated the chamber depth could be calculated. It was desired that each chamber have the same depth.

$$C = 2\pi \sqrt{\left(\frac{a^2 + b^2}{2}\right)} \quad \text{Eq. 3}$$

To keep the chamber depths equal, the GSI used Equation 3 to approximate the circumference of an ellipse in which one axis diameter was the chamber width and the other axis diameter was twice the desired chamber depth. In Equation 3, a is the short axis half diameter and b is the long axis half diameter. Once the approximate circumference had been calculated, the GSI knew how much material was need in the crenulations for each of the twelve chambers.

The final feature that was added to the chamber shape had to do with the bottom portion of the membrane. Instead of having the chambers come to a point at the apex it would be beneficial to have the chambers come to flat edge such that when assembled the bottom of the membrane would create a hole. This hole would not only help make the membrane easier to assemble but would also allow for a vacuum to be place at the bottom of the membrane. This vacuum could be used to suction any unwanted air or fluids between the membrane and the epicardial surface.

9.3 Inflation Points

During the trial and adjustment process of developing the inner membrane, several methods of inflating the device were examined. Ultimately, the GSI decided to use grommets to create inlet holes for vinyl tubing that could be used to inflate the device. Initially brass grommets were used to create these inlet holes, however the GSI found that the brass grommets were too sharp for the polyethylene sheets and often cut through the plastic. It was determined that plastic grommets would be more functional for this application. The grommets used for the final inner membrane were made from Nylon 6,6. A rubber o-ring was used between the male and female pieces of the grommets to further tighten the seal. The inflation points, one for the right side and one for the left side of the membrane, were placed in the upper portion of the device directly in the middle of the collective chambers. This position of the inflation points was chosen based on the design criteria. First, it was desired that the lower portion of the membrane be relatively flat. Therefore the upper portion was chosen because having an inflation point in the lower region of the membrane would neglect this requirement. The middle of the collective chambers was chosen to best keep the air resistance of each chamber equal.

CHAPTER X

AIM II MANUFACTURING PROCESS

For the manufacturing process, all of the dimensions were based on an ovine heart that was 4.4" from top to bottom, 3.5" along the valve plane in the major axis direction, and 3" in the minor axis direction. The calculation of the membrane dimensions will be discussed in the modeling section. Before the membrane could be constructed several tools had to be machined to melt the plastic sheets together. First, seven straight brass bars and six curved copper bars had to be machined to the proper dimensions needed to separate the chambers. The brass bars were cut from a long brass rod with a diameter of .3" using a lathe. Each piece was first cut and then smoothed to eliminate rough edges. The copper bars were cut from a 0.25" thick plate of copper. Strips approximately one inch wide were cut from the plate and smoothed using a belt sander. The strips were then placed in a rolling metal bender to bend the copper pieces to the necessary shape. Finally the copper bars were cut to the necessary height and smoothed once again. The final melting tool needed was for the top weld of the membrane. This part was machined out of copper just like the curved bars. The metal bender was used to bend the copper bar into the shape of the cosine curve and then the bar was cut to the necessary length. Now that the melting tools had been machined, the membrane was ready to be constructed.

All of the melting tools were placed in an oven at 180° C and heated for approximately one hour. A 4 mil piece of polyethylene was used as the bottom sheet and a 2 mil piece of polyethylene was used as the top sheet. Using the first of the seven brass bars, the top sheet of polyethylene was melted to the bottom sheet. The two sheets of

polyethylene were melted together by placing a sheet of the heat resistant wax paper under the polyethylene sheets and one on top of the polyethylene sheets. Then the brass bar was positioned and held firmly to the sheets for approximately 40 seconds creating a smooth weld the same length of the bar. For the next weld the proper crenulation was added to the top sheet and then melted at the desired chamber width. This weld was positioned such that the bottom of the weld was lined up with the bottom of the first weld. The entire process of adding crenulations and melting the two sheets together at the desired chamber widths was repeated until all of the welds separating the chambers had been created. Next, the curved copper bars were used to melt the sheets together and close off the bottom of the chambers. The copper bars were used in the same manner as the brass bars. A sheet of heat resistant wax paper was placed above and below the sheets. Then the copper bars were positioned and pressed to the sheets firmly for approximately 40 seconds.

After all of the chambers had been completed, the inflation points were installed. First a hole was burned through the bottom polyethylene sheet in the proper location of the inflation point. The nylon grommets used had a diameter of 0.6875", an inner hole diameter of 0.25", and a thickness of 0.25". The male part of the grommet was stuck through the hole and a #47 rubber o-ring was placed on top of the grommet and polyethylene sheet. Finally, the female part of the grommet was snapped onto the male part of grommet. The entire process was repeated for the other inflation point.

Now that the inflation points had been added the membrane could be completely sealed. Before the top cosine shaped weld was added to the membrane, a crenulation was

added to the upper portion of the top sheet in order to allow the upper portion of the membrane to have more depth than the lower portion. The crenulation depth of the upper portion was twice that of the chamber crenulations' depth. The top weld was then created in the same manner as all of the other welds. To finish the seals the weld between the left and right heart that ran the entire height of the device was added as well as the welds on the far left and right sides of the device that sealed the upper portion.

The final task before assembly was to flatten the bottom portion of the membrane to account for the hole in the bottom of the device. This was accomplished by simply adding a weld along the entire bottom of the membrane in the same manner as all of the other welds. Now the membrane could be assembled and the portions between the chambers were cut out and the chamber edges were welded together. The chamber edges were welded together with the device in the inverted position so that all of the welds would be contained on the inside portion of the device. This was done so that the outside of the device was smooth so that the vacuum device on the bottom of the membrane would have a better seal. Once the last chamber edges were welded together the membrane was turned right side out and the assembly was complete.

CHAPTER XI

AIM II MODELING

One of the goals of the GSI was to be able to construct the inner membrane for any sized ovine heart. To accomplish this goal all of the dimensions of the inner membrane had to be based on dimensions of the heart it was to be used for. Table 5 shows the heart dimensions used to create the inner membrane and Table 6 shows the corresponding device dimensions.

All of the device dimensions are based on percentages of the actual heart dimensions and are the dimensions prior to final assembly. The maximum height of the device was taken to be 8% larger than the top to bottom height of the heart, and the minimum height of the device was taken to be 68% of the top to bottom height of the heart. As previously mentioned, the circumference the heart was approximated using Equation 3. The circumference of the device was taken to be 10% larger than the circumference of the heart. The upper portion height was taken as 33% of the minimum height of the device and the upper crenulation depth was 72.1% larger than the difference between the device diameter and the minor axis diameter of the heart. The chamber crenulation depths were taken as half of the upper crenulation depths. The upper portion crenulation length and chamber crenulation lengths were calculated using Equation 3.

Table 5
Dimensions of heart used for the constructions of the inner membrane.

Heart Dimensions	
Top to Bottom Height	4.4"
Valve Plane Major Axis Diameter	3.5"
Valve Plane Minor Axis Diameter	3.0"

Table 6
Inner membrane dimensions based on the dimensions of the heart used to construct the membrane.

		Chamber Division Number	Height
Maximum Height	4.75"	1	3.75"
Minimum Height	3.00"	2	3.55"
Circumference	11.25"	3	3.08"
Chamber Crenulation Depth	0.50"	4	2.61"
Upper Portion Height	1.00"	5	2.27"
Upper Crenulation Depth	1.00"	6	2.07"
Upper Crenulation Length	1.57"	7	2.00"

	Chamber Number	Widths	Crenulation Lengths
	1	1.24"	1.77"
	2	1.13"	1.68"
	3	0.97"	1.55"
	4	0.83"	1.44"
	5	0.74"	1.38"
	6	0.70"	1.36"

The chamber division heights which are the lengths of the brass bars used to make the chamber division welds were calculated using the cosine equation, Equation 4.

$$h_i = A \cos\left(\frac{2\pi}{L} l_i\right) + C \quad \text{Eq. 4}$$

In Equation 4, A is amplitude, L is the entire length, l_i is the corresponding length for the height h_i , and C is the y-axis shift. As previously discussed, the chamber widths were calculated using a MATLAB® program in which the inputs were the device circumference, minimum device height, maximum device height and the upper portion height. A Microsoft Excel worksheet was developed to calculate the other device dimensions previously discussed. Therefore, dimensions for a different sized membrane could easily be calculated from the three heart dimensions needed using this Excel worksheet and MATLAB® program. The MATLAB® program used can be found in Appendix B.

CHAPTER XII

AIM II DEVICE EVALUATION

Most of the device specifications of the inner membrane were based on the shape and size of the membrane. The membrane needed to be manufactured to function for a heart of a particular size and approximate the shape of the heart to help the membrane apply a uniform pressure to the heart. Both of these tasks were accomplished for the ovine heart used to make this membrane. Since the membrane was only created for one particular sized heart some of the modeling dimensions may have to be adjusted slightly for a different sized heart. The requirements set out by the GSI did not include that the modeling apply to all sized hearts. It would be basically impossible to develop one model to apply to all hearts due to the complex differences seen from heart to heart. It was the goal of the GSI to develop a model that could be applied to most ovine hearts, which was accomplished.

The membrane had to also be able to withstand a pressure required to compress the heart. Unlike the outer shell, the inner membrane, when implanted, will be constructed of materials used in this process. Therefore, the GSI decided that pressurizing the inner membrane would be relevant in this study. Based on previous works of Dr. Criscione, it was decided that a pressure of 9 kPa would be sufficient to compress the heart. A hydro pump, seen in Fig. 21, was used to fill the membrane and pressurize it with air. An aquarium pump was used as the driving force to pressurize the membrane. As the pump forces air down the pipe a pressure gradient is built up in the air line. The water level

difference in the chamber and the air supply line determines the air pressure in the line.

The membrane was able to withstand the needed pressure of 9kPa.

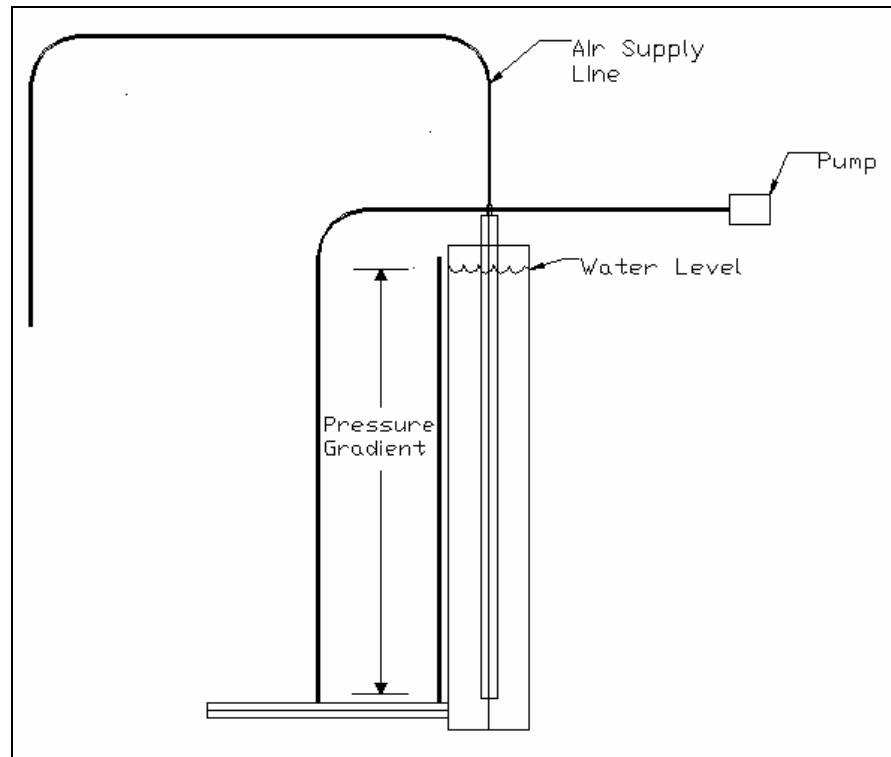

Fig. 21: Schematic of hydro pump used to pressurize the inner membrane.

CHAPTER XIII

AIM II FUTURE CONSIDERATIONS

No major problems were encountered during the most recent development of the inner membrane. Unlike the outer shell developed in Aim I, the inner membrane was constructed several times and most of the design problems encountered in early assemblies were corrected in later developments. The only down side to the fabrication process is that it does take quite a bit of time. It takes several hours to develop just one inner membrane since the procedure is done by hand. Constructing the membranes by hand also leaves a larger room for human error. It would be beneficial to develop a system for the melting of the polyethylene sheets that would take some of the human error out of the process. To develop a system like this would require expensive machinery which was not at the GSI's disposal.

Not only was it important to make sure the membrane could withstand the desired pressure but it would also be beneficial to test the inner membrane for fatigue failure properties. When the membrane is ready to be implanted, it will be vital to know how many times the membrane can be inflated and deflated without failing. Dr. Criscione and the GSI felt that fatigue failure testing would be premature at this point.

CHAPTER XIV

SUMMARY

Based on the current state of heart problems in America, namely CHF, there has become a need for devices that not only assist the heart but help it to grow and remodel back to its normal configuration. It was the goal of the GSI to design and construct two key components of such a novel device. The first goal was to design and construct an adjustable outer shell which will enable the device to become smaller as the failing heart returns to normal size. The second goal was to design and construct an inflatable inner membrane that applies direct pressure to the epicardial surface in a way that promotes physiological stress and strain patterns. The GSI was able to complete all of the tasks and meet all of the specifications outlined within this work for both of the key components for the novel DCCD.

REFERENCES

- American Heart Association (AHA 2003). Heart Disease and Stroke Statistics-2004 Update. Dallas, TX: American Heart Association.
- Anstadt, M.P., Schulte-Eistrup, S.A., Motomura, T., Soltero, E.R., Takano, T., Mikati, I.A., Nonaka, K., Joglar, F., Nose, Y., 2002. Non-blood contacting biventricular support for severe heart failure. *The Annals of Thoracic Surgery* 73, 556-562.
- Humphrey, J.D., 2002. *Cardiovascular Solid Mechanics: Cells, Tissues, and Organs*. Springer, New York, 166-178, 674.
- MatWeb, Material Property Data: ASTM A228. <http://www.matweb.com/search/SpecificMaterial.asp?bassnum=MSASTMA228>, June 2003.
- Taber, L.A., 2001. Biomechanics of cardiovascular development. *Annual Reviews of Biomedical Engineering* 3, 1-25.
- Terracciano, C.M., Harding, S.E., Adamson, D., Koban, M., Tansley, P., Birks, E.J., barton, P.J., Yacoub, M.H., 2003. Changes in sarcolemmal Ca entry and sarcoplasmic reticulum Ca content in ventricular myocytes from patients with end-stage heart failure following myocardial recovery after combined pharmacological and ventricular assist device therapy. *European Heart Journal* 24(14), 1329-1339.

APPENDIX A

TOP PLATE TOP VIEW

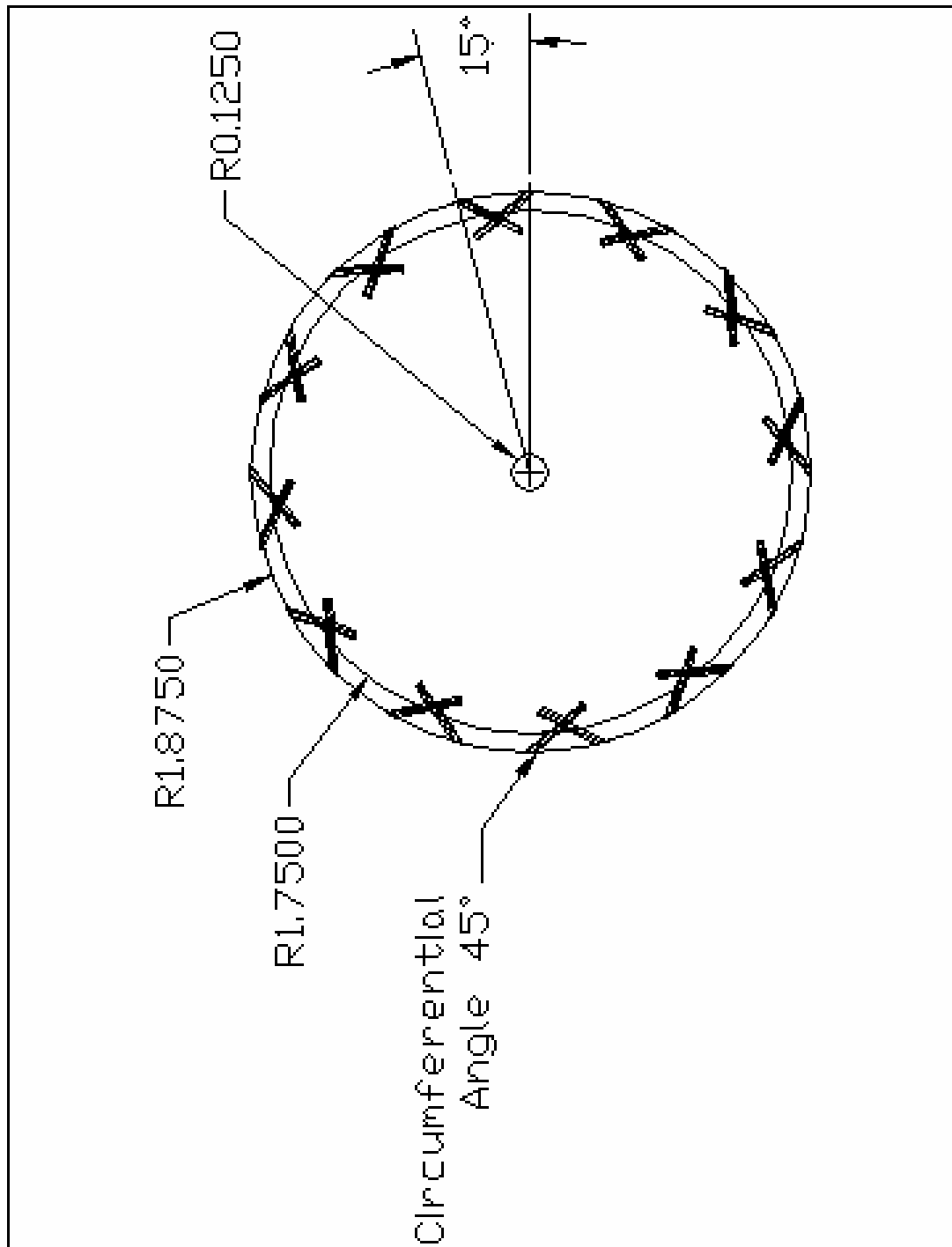

TOP PLATE RIGHT SIDE VIEW

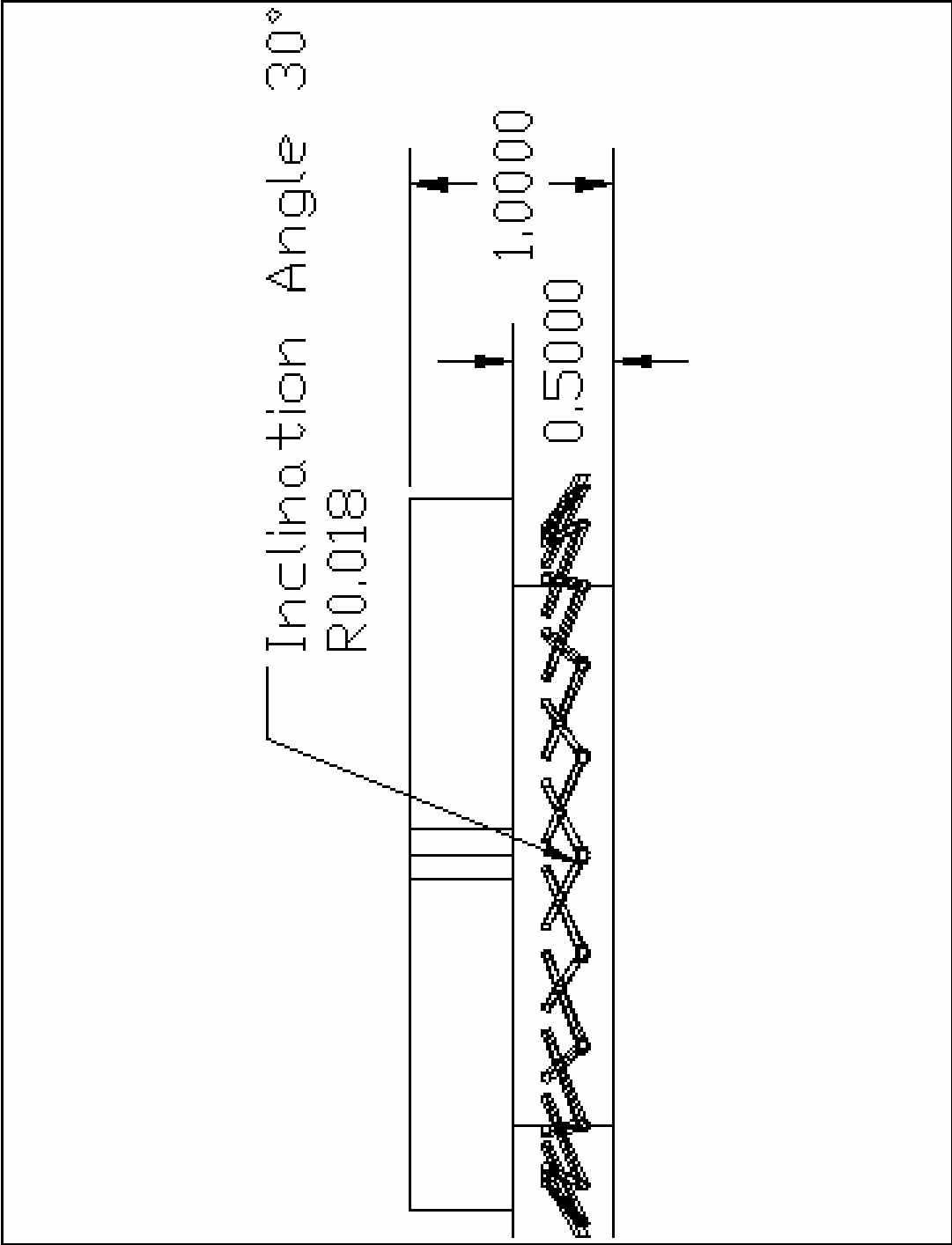

BOTTOM PLATE TOP VIEW

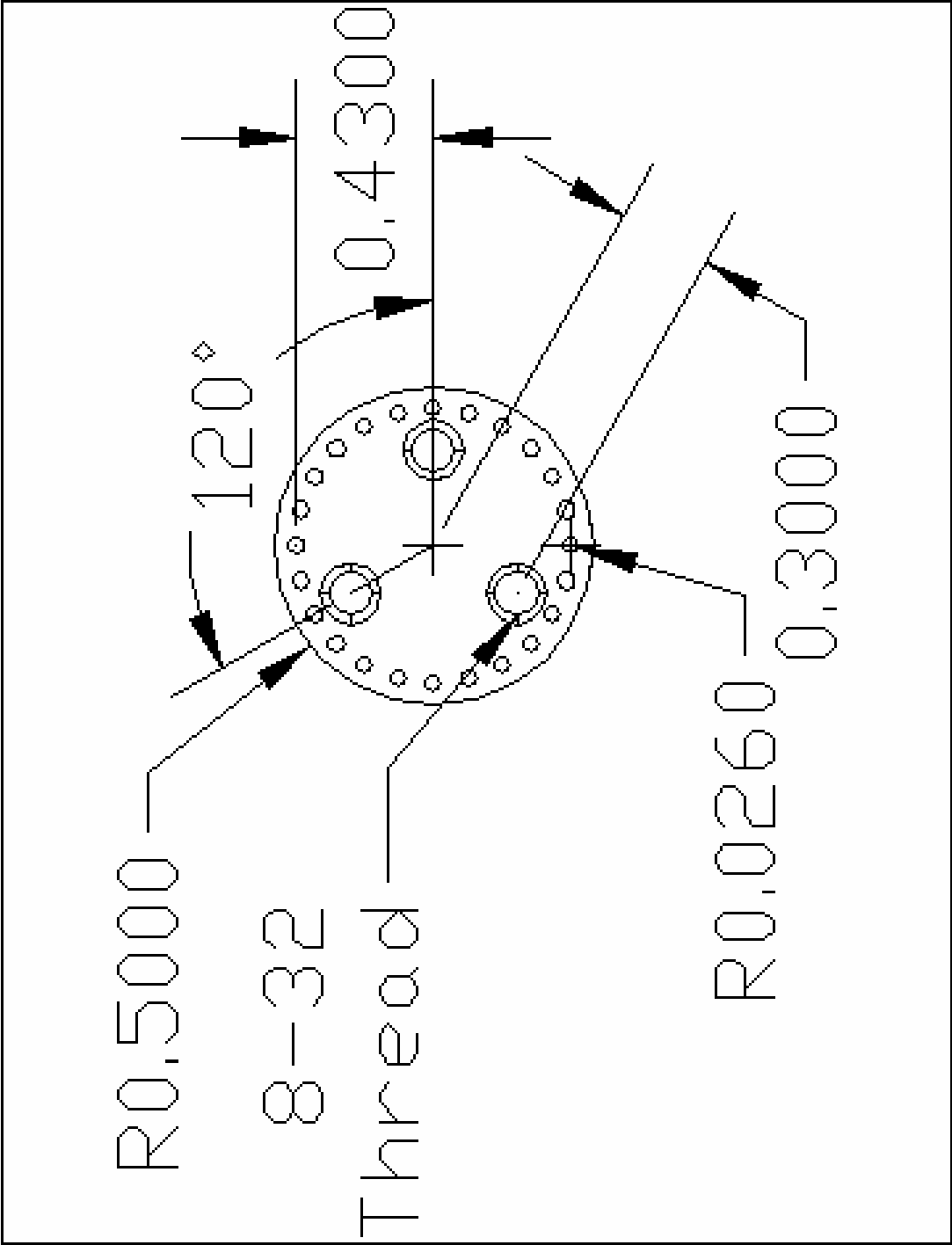

BOTTOM PLATE RIGHT SIDE VIEW

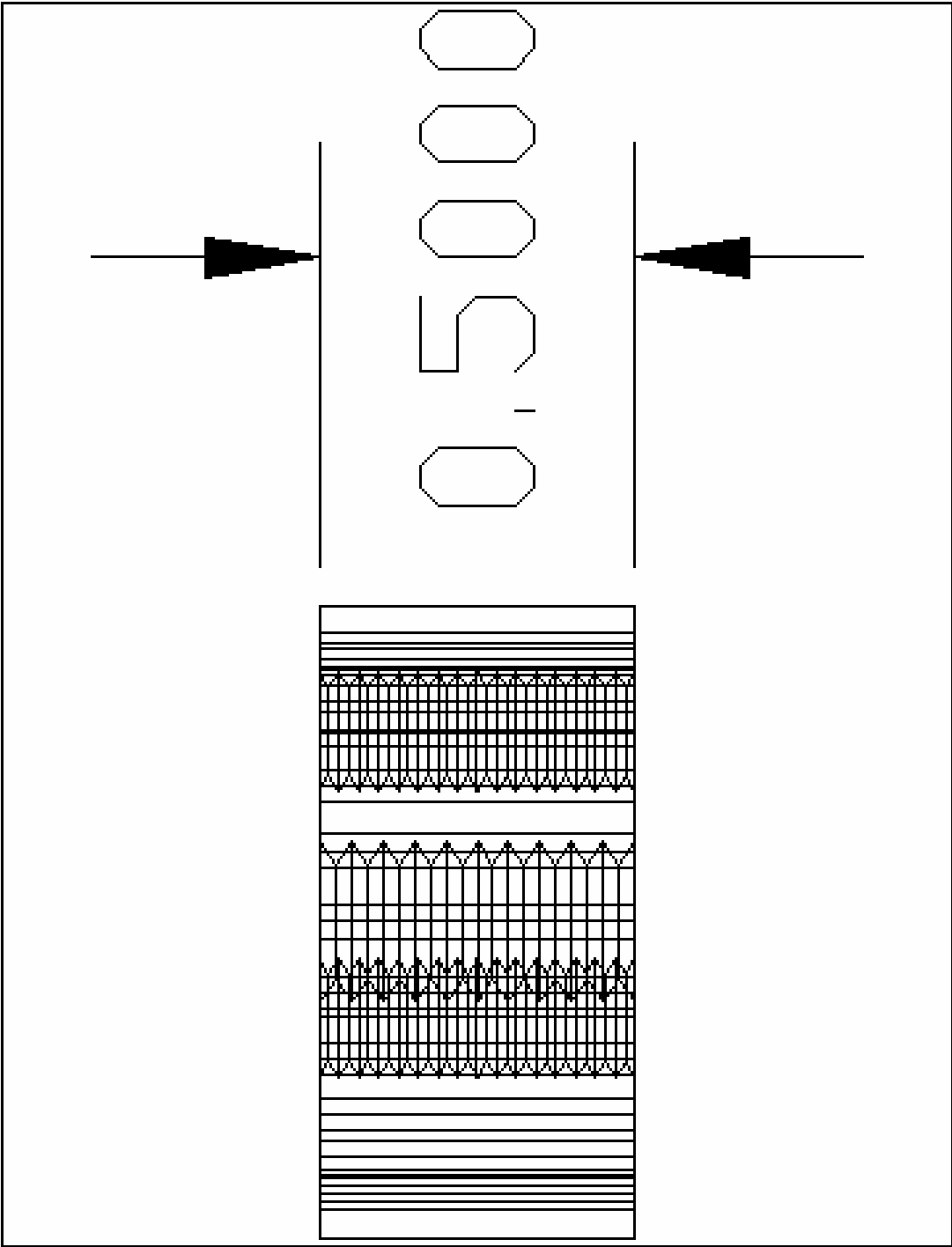

CYLINDER TOP VIEW

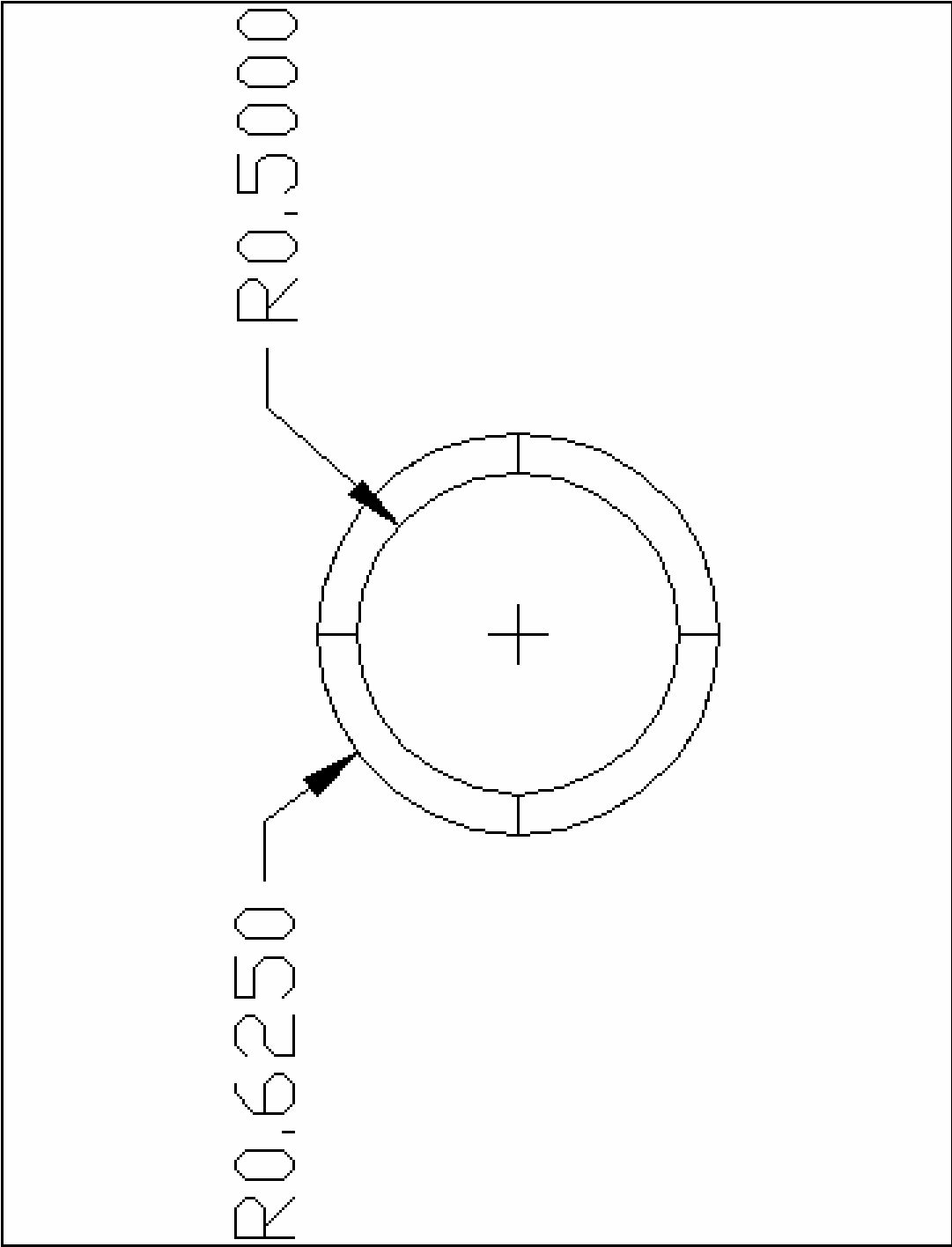

CYLINDER RIGHT SIDE VIEW

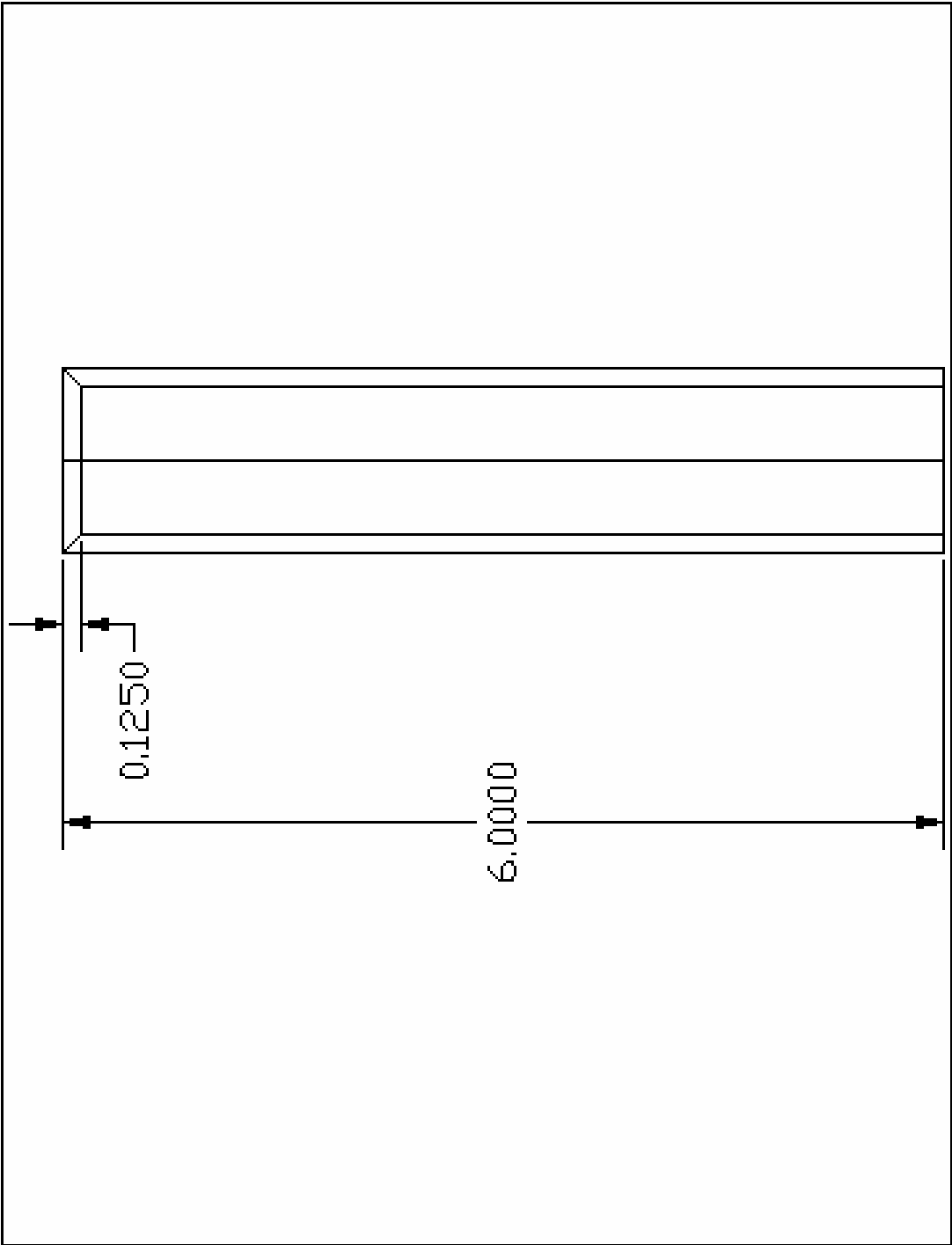

CYLINDER PLUG TOP VIEW

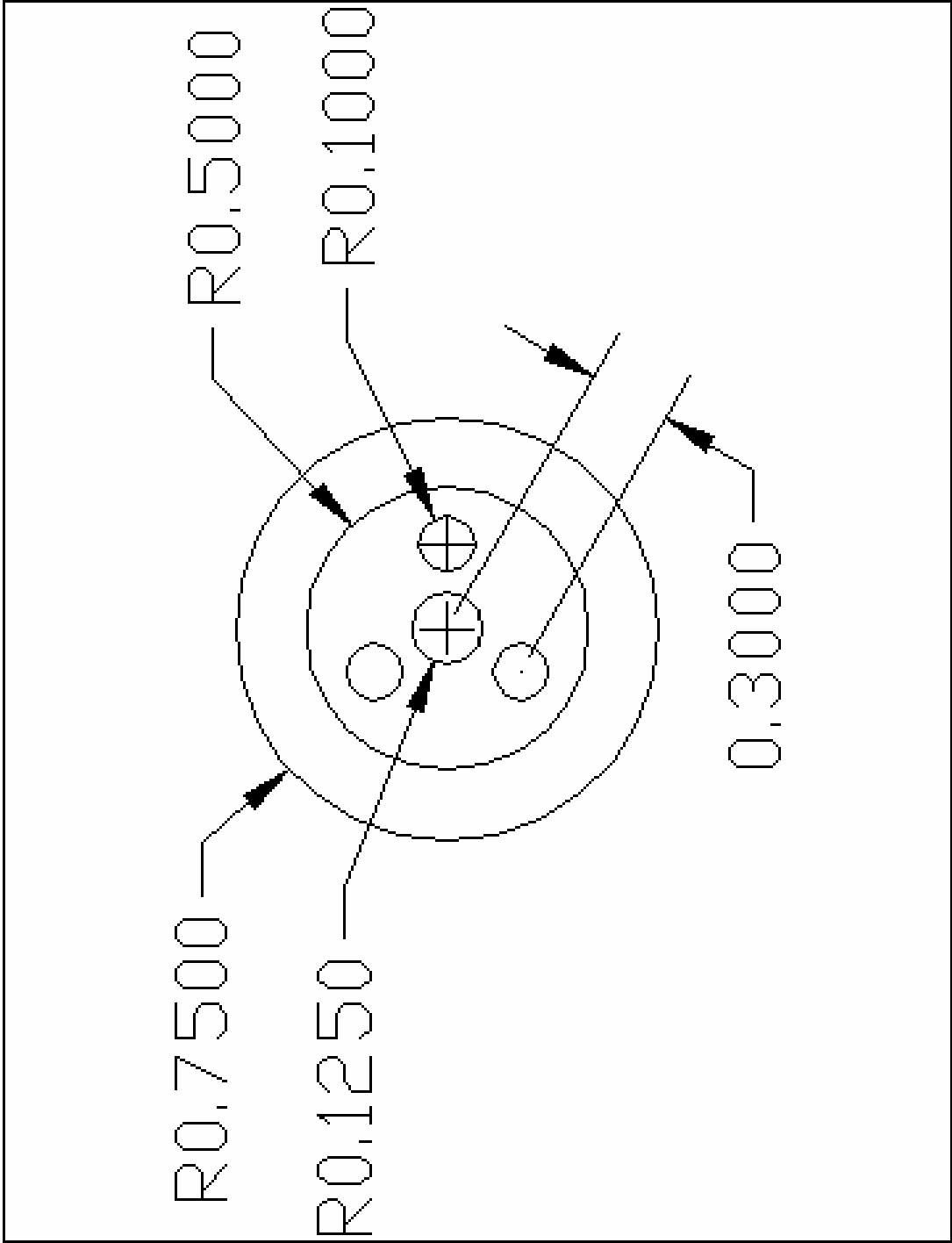

CYLINDER PLUG RIGHT SIDE VIEW

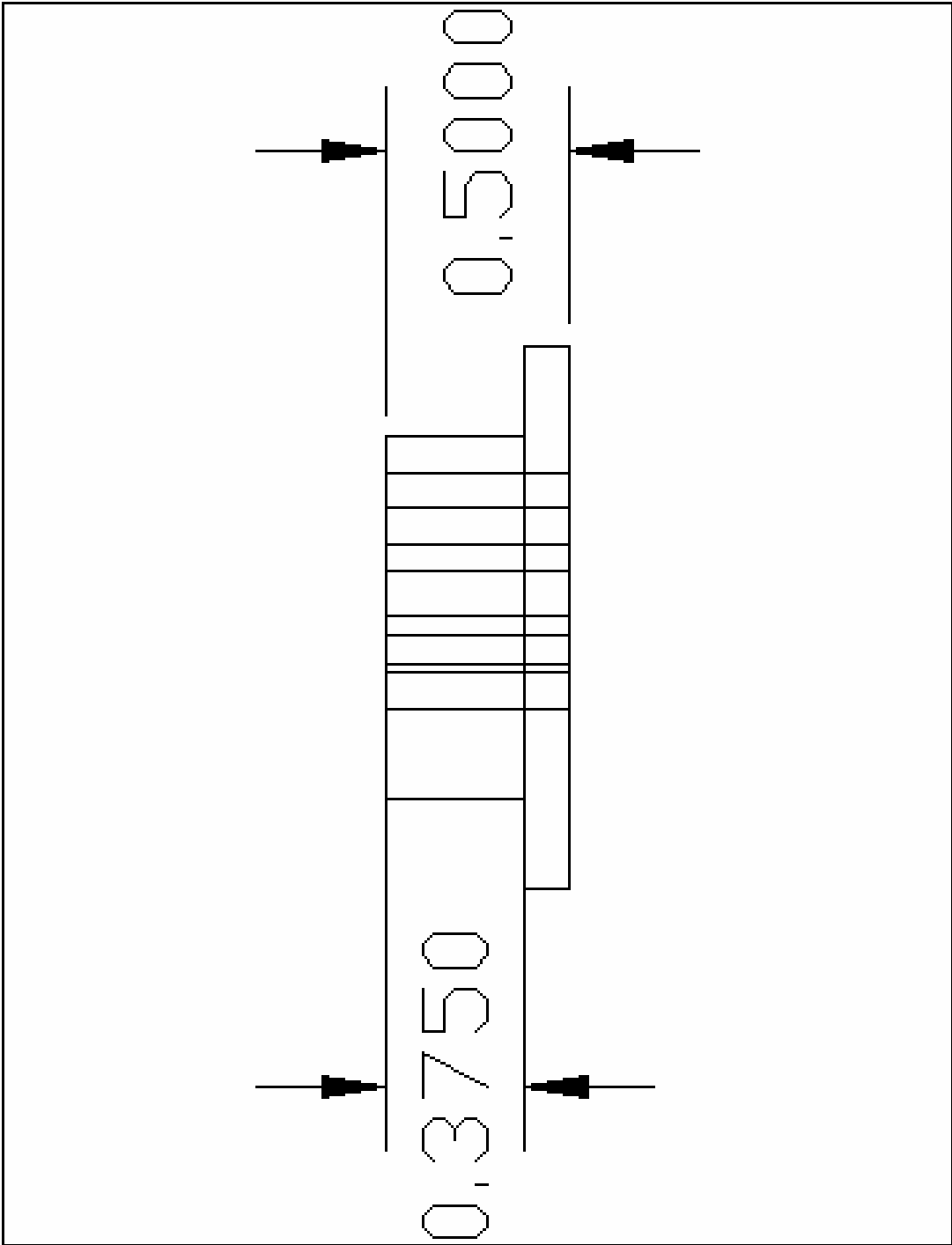

THREADED ROD HEAD TOP VIEW

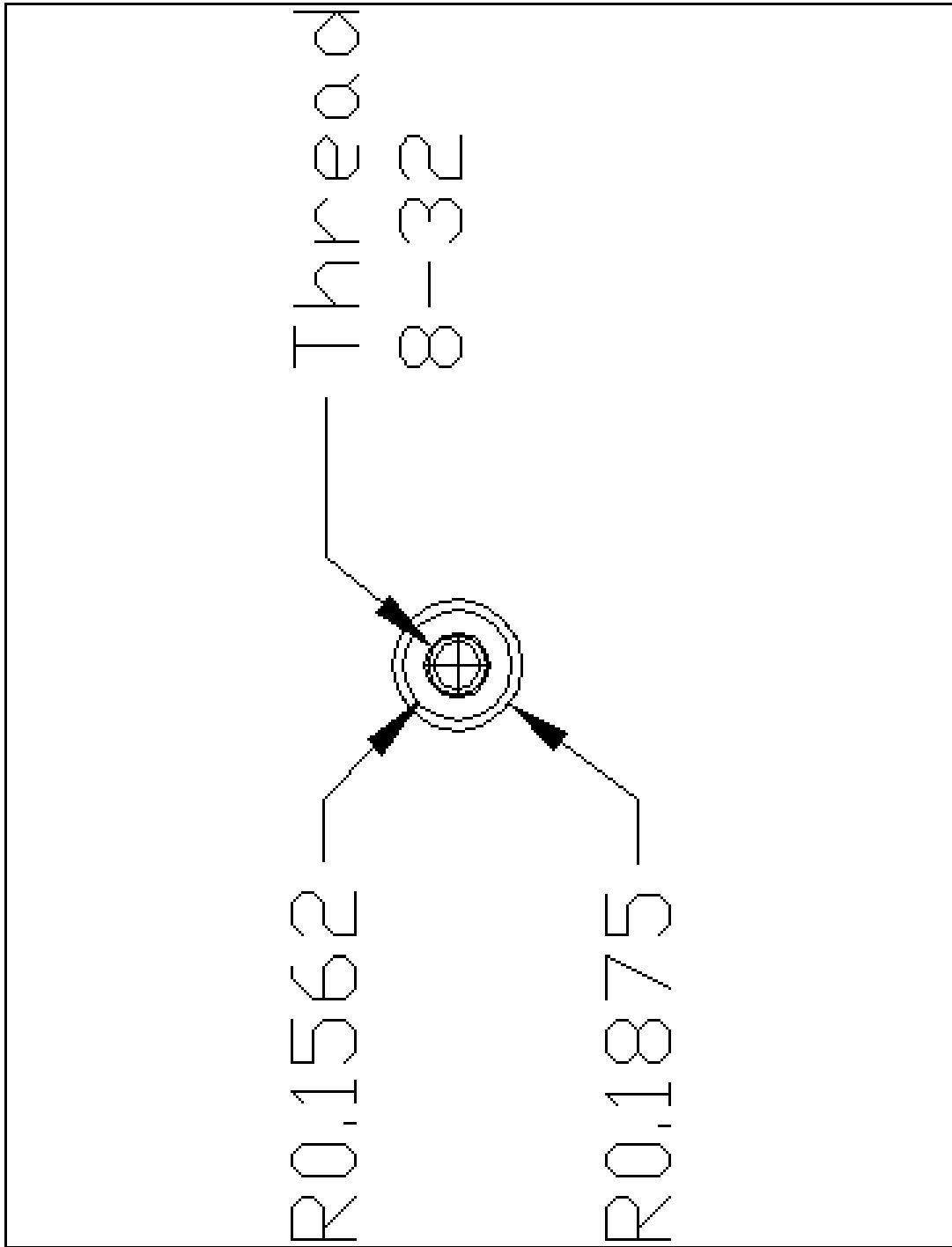

THREADED ROD HEAD RIGHT SIDE VIEW

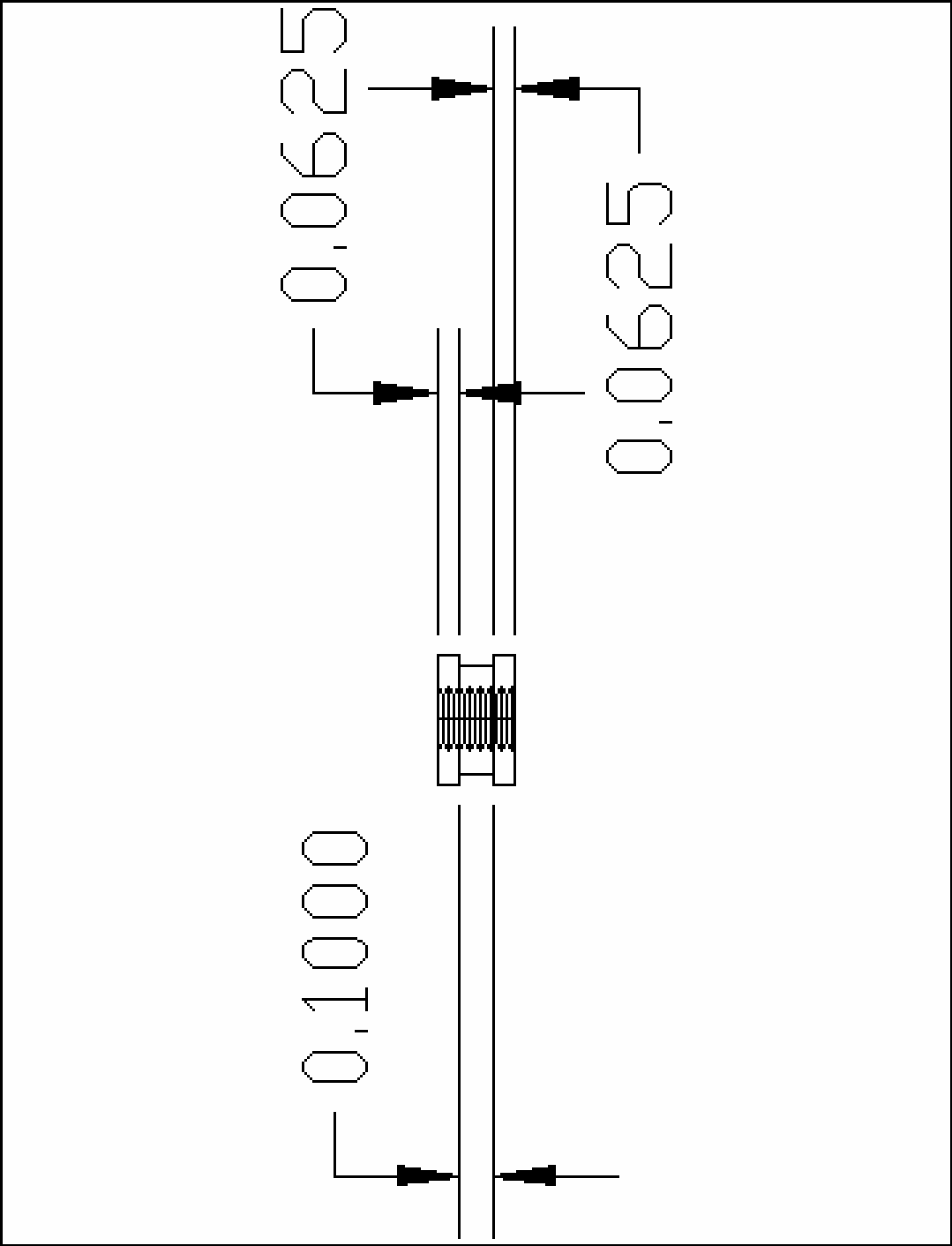

FULL ASSEMBLY RIGHT SIDE VIEW

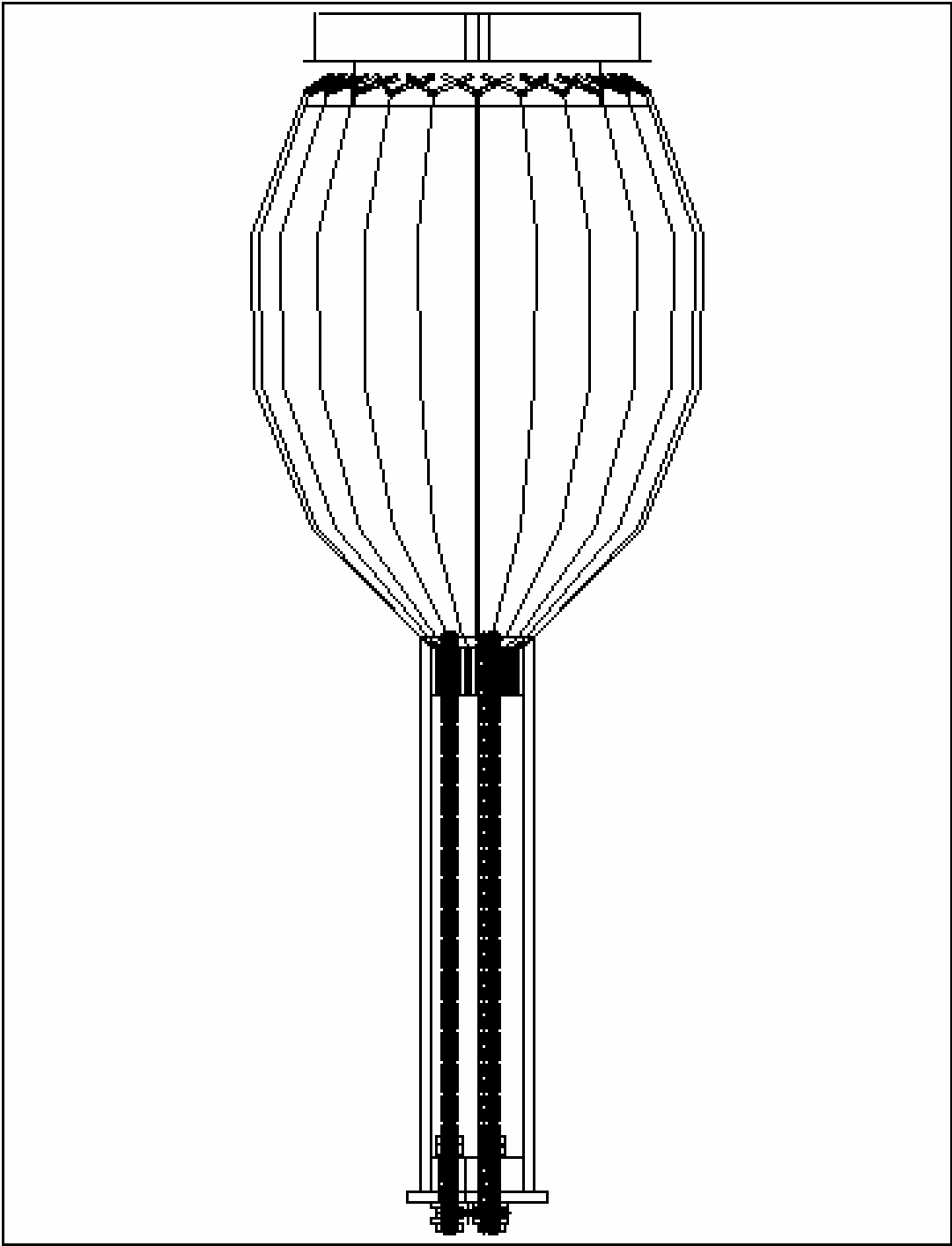

APPENDIX B

MATLAB PROGRAM I

```

%Calculates the chamber division widths.

clear all

close all

Ltot = 11.25;

beta=(4.75+2)/2;

alpha=0.5*(4.75-2)/beta;

L_vec=[0 1 2 3 4 5 6]*Ltot/12;

%n=12/2;

a_ratio=Ltot/12/beta;

start_vals=[L_vec a_ratio]';

A=[]; b=[];

Aeq=zeros(8,8); Aeq(1,1)=1; Aeq(7,7)=1;

beq=[0 0 0 0 0 0 L_vec(7) 0]';

lb=zeros(8,1);

ub=[];

x = fmincon('get_e_tot',start_vals,A,b,Aeq,beq,lb,ub);

soln_4_L=[x(1:7)' Ltot-x(6) Ltot-x(5) Ltot-x(4) Ltot-x(3) Ltot-x(2) Ltot-x(1)]'

soln_4_H=beta*(1+alpha*cos(2*pi*soln_4_L/Ltot))

plot(soln_4_L,soln_4_H,'o');hold on; plot(0,0)

a_ratio=x(8)

%get_e_tot(soln)

```

MATLAB PROGRAM II

```
%Calculates the error between the solutions.  
  
function E_tot = get_e_tot(current_vals)  
  
Ltot = 11.25;  
  
L_vec=current_vals(1:7,1)';  
  
a_ratio=current_vals(8,1);  
  
n=6;  
  
beta=(4.75+2)/2;  
  
alpha=0.5*(4.75-2)/beta;  
  
E_vec=(L_vec(2:(n+1))-L_vec(1:n))-a_ratio*beta*(2+alpha*(cos(2*pi*L_vec(2:(n+1))  
    /Ltot)+cos(2*pi*L_vec(1:n)/Ltot)))/2;  
  
E_tot=sqrt(sum(E_vec.*E_vec));
```

VITA

Name: Lewis D. Harrison Jr.
Address: 2127 Chapel Downs
Arlington, TX 76017
Degree: Bachelor of Science
Biomedical Engineering
Texas A&M University