



45<sup>TH</sup> **TURBOMACHINERY** & 32<sup>ND</sup> **PUMP SYMPOSIA**  
HOUSTON, TEXAS | SEPTEMBER 12 – 15, 2016  
GEORGE R. BROWN CONVENTION CENTER

# Double Flow Refrigeration Compressor Inlet Piping Design and Analysis

**Jeremy Hayes**  
Machinery Engineer  
ExxonMobil  
Spring, TX, USA

**Vincent E. Mankowski**  
Machinery Engineer  
ExxonMobil Research &  
Engineering (Annuitant)  
Warrenton, VA 20187

**Pablo Bueno, PhD**  
Senior Research Engineer  
Southwest Research Institute  
San Antonio, TX, USA



TEXAS A&M  
UNIVERSITY



# Authors Bio

- **Vincent E. Mankowski (Vince)** is an ExxonMobil Research and Engineering (EMRE) Machinery Annuitant. He has worked in the turbomachinery field for 45 years. In his current capacity as a consultant, he provides support to machinery related projects including project development, equipment specification, bid evaluation, design reviews and testing. His expertise includes rotor/thermo dynamics analysis. While at EMRE he participated in many worldwide projects for ExxonMobil Downstream and Upstream Production. Prior to joining EMRE, he held the position as a compressor and turbine applications engineer at Elliott Co. providing applications engineering for many world scale ethylene and LNG compressor trains. Mr. Mankowski received his BSME (1968) from Virginia Polytechnic Institute) and a MBA (1978) from Rutgers The State University.
- **Jeremy Hayes** is an ExxonMobil Research and Engineering (EMRE) Machinery Engineer. He has worked in the turbomachinery field for 7 years. Within ExxonMobil he has provided support for machinery related projects including development, specification, evaluation, design review and testing as well as site asset support activities. He currently is on assignment at the ExxonMobil Refinery in Rotterdam, Netherlands. Mr. Hayes received his BSME (2009) from Lamar University in Beaumont, TX.
- **Pablo Bueno** is a Senior Research Engineer in the Fluid Machinery Systems section of the Mechanical Engineering Division at Southwest Research Institute (SwRI). He has 10 years of R&D experience in the oil and gas, and energy sectors with emphasis on fluid systems. His expertise includes experimental and computational analysis of oilfield machinery, development of thermal energy storage methods for concentrated solar plants, and thermal stress analysis of piping systems. Prior to joining SwRI, Dr. Bueno was a design engineer at FMC Technologies and a postdoctoral research associate at the City College of New York. Dr. Bueno obtained a BS degree in aeronautical engineering from the United States Air Force Academy in 1998, and MS and PhD degrees in aerospace engineering from the University of Texas at Austin in 2002 and 2006 respectively.

# Objective

- Design an inlet piping system for a double flow centrifugal compressor that effectively utilizes existing site spacing constraints:
  - Distributes flow to each inlet evenly with minimal pressure loss and without gas swirl or other flow disturbances that may cause long term compressor performance and mechanical reliability issues
  - Utilizes standard piping components for construction and minimizing piping support structure to minimize capital investment
  - Offers simple control methodology eliminating the need for flow control valves and a complicated control system
  - Provide most effective design solution with minimal engineering hours and reviews

# Project Background

- New single Refrigeration Compressor replaces two existing parallel flow compressors currently in operation
- The compressor selected as a double flow unit to allow the selection of a smaller foot print compressor and a smaller more efficient steam turbine
- New compressor installed within existing plant location and space is constrained within operating units
- Compressor operating conditions cover a wide flow range including summer and winter cases, turndown case and other process flow requirements.
- Driver is variable speed steam turbine and compressor operates against a fixed discharge with inlet pressure controlled by speed
- Compressor aerodynamic performance and mechanical operation are highly dependent upon flow and pressure balance between the two parallel compression paths.
- The design and layout of the compressor inlet piping is critical to achieving the required flow balance, minimizing preferential loading to either compressor inlet nozzle and minimizing performance losses due to flow disturbances in the gas.

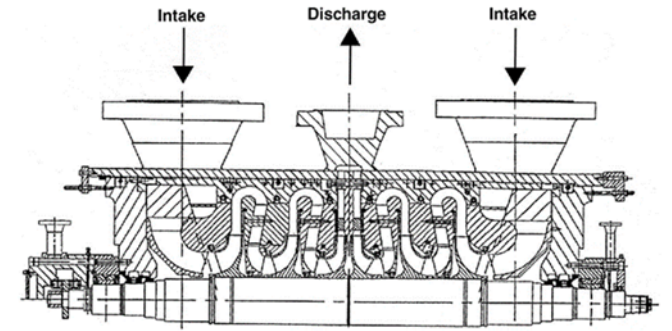

# Initial EPC Inlet Piping Design

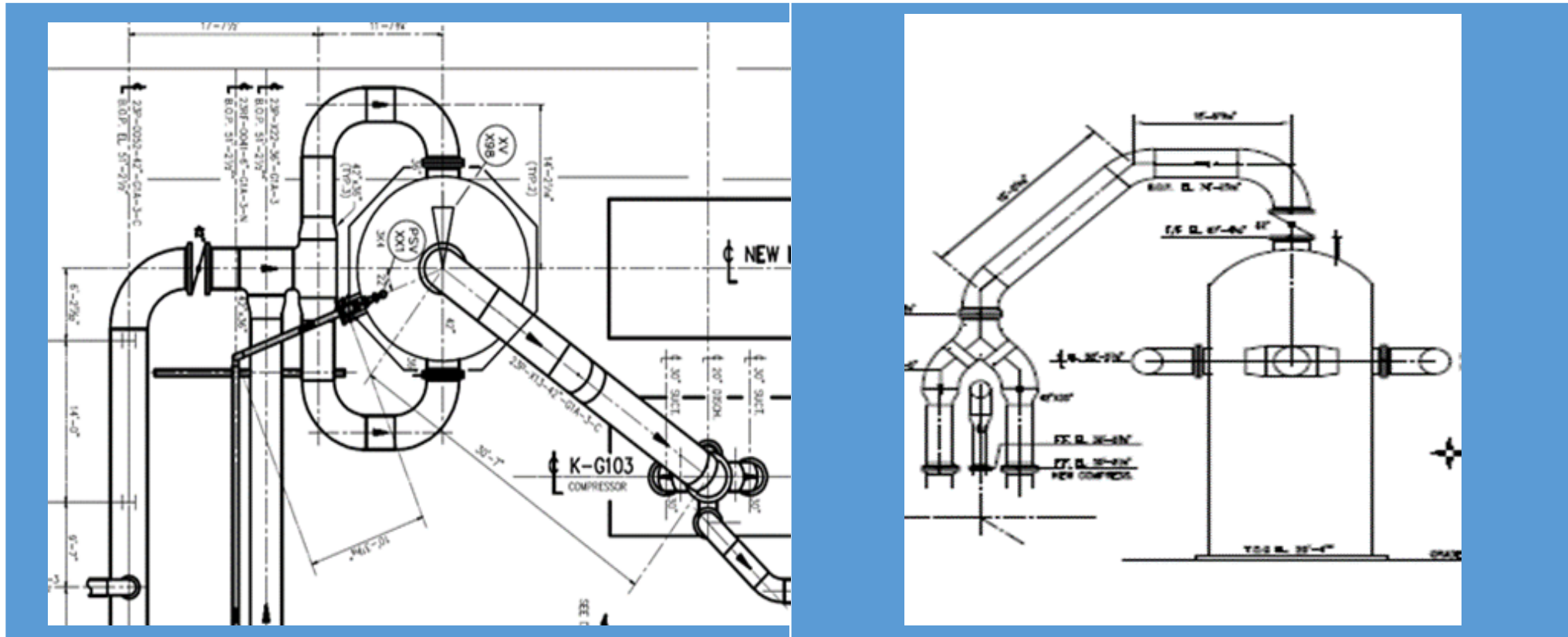

- Project EPC original drawing for the inlet piping. Presented as the most cost effective solution given the existing unit spacing constraints, but without consideration to compressor performance impacts.

# Vendor Guidance for Compressor Inlet Piping

- Vendor guidance on the flow variation can be summarized as follows:
  - Expectation for a double flow compressor is inlet flow conditions are maintained in an equivalent manner. This is typically accomplished via fixed designed upstream piping and hardware that accomplishes equivalent inlet conditions, or through controllable process equipment such as valves, coolers, etc.
  - Vendor views the efficiency reductions associated with higher flow differential to be significant. The willingness to accept the operating penalty must be determined by the user, in part weighing the potential cost to avoid or minimize the differential split flow.
  - Potential reduction in operating margin, either towards surge or towards choke, is likewise a factor to be determined by the operator to its significance. Operation needs to be maintained in acceptable region of the operating map for both sections at all times.
- Vendor guidance does consider added capital investment (and future maintenance costs) or control system complexity

## *Traditional Inlet Piping Design Approach Summary*

- Guidance provided in “Centrifugal Compressor Inlet Piping – A Practical Guide” Hackel & King was utilized by the EPC
- EPC design criteria based on above:
  - Indicates to achieve laminar flow before and after flow-split, a minimum of 3.5 to 4 straight pipe diameters are required before and after the “Y” Splitter.
  - Methodology does not consider the internal piping flow dynamics to determine flow split after the Y-Splitter.
- *CFD Based Piping Analysis* of EPC design found the compressor will experience non-symmetrical flow distribution as well as potentially excessive gas swirl.

# CFD BASED PIPING ANALYSIS













- A 3-D model was generated using the original piping layout drawings from the knockout drum to the compressor nozzle inlets.
- Model was meshed using the ANSYS meshing tool.
  - Regions of high gradients were locally refined
  - Inflation layers were used to resolve the boundary layer.
  - Turbulence model:  $k-\omega$  with wall functions
  - Two sets of flow conditions were used: rated and turndown.
  - Strainers were simulated as porous elements with friction losses in the stream-wise direction and with a porosity of 50%.



# CFD BASED PIPING ANALYSIS

- Boundary conditions:
  - Flow rate at the inlet of fluid space (outlet of KO drum)
  - Pressure boundary condition at both outlets of fluid space (inlets of the compressor)
  - Flow velocity is implicitly calculated.
  - The flow rate at both outlets is monitored to ensure convergence.
- For the final configuration, two additional studies were conducted:
  - A grid dependence study to ensure the solution did not depend on the size or shape of the elements.
  - The boundary conditions were modified such that a fixed pressure was prescribed at the suction drum and flow rates were enforced at the compressor nozzle inlet.
- The mixture was modeled as an ideal mixture.

# CFD BASED PIPING ANALYSIS – Configurations Considered

					
(a) 28% deviation	(b) 3.5% deviation	(c) 4% deviation	(d) 3% deviation	(e) Inlet swirl too high	(f) Inlet swirl too high
					
(g) 5% deviation	(h) Inlet swirl too high	(i) Inlet swirl too high	(j) Inlet swirl too high	(k) Guide vanes added	(l) Final – simpler design

# CFD BASED PIPING ANALYSIS - Results

Iteration	% Flow Deviation Between Inlet Nozzles	Reason for Modification
a	27.5	Original Design
b	3.4	Flow difference too high
c	3.6	Flow difference too high
d	3.3	Flow difference too high
e	1.1	Swirl too high
f	2.4	Swirl too high
g	4.6	Swirl too high, Flow difference too high
h	1.3	Swirl too high
i	.0	Swirl too high
j	0.2	Acceptable design
k	2.1	Attempt to reduce swirl by using guide vanes
l	0.1	Allows use of single bend compared to iteration (j), mechanically simpler

# CFD BASED PIPING ANALYSIS – Results Final

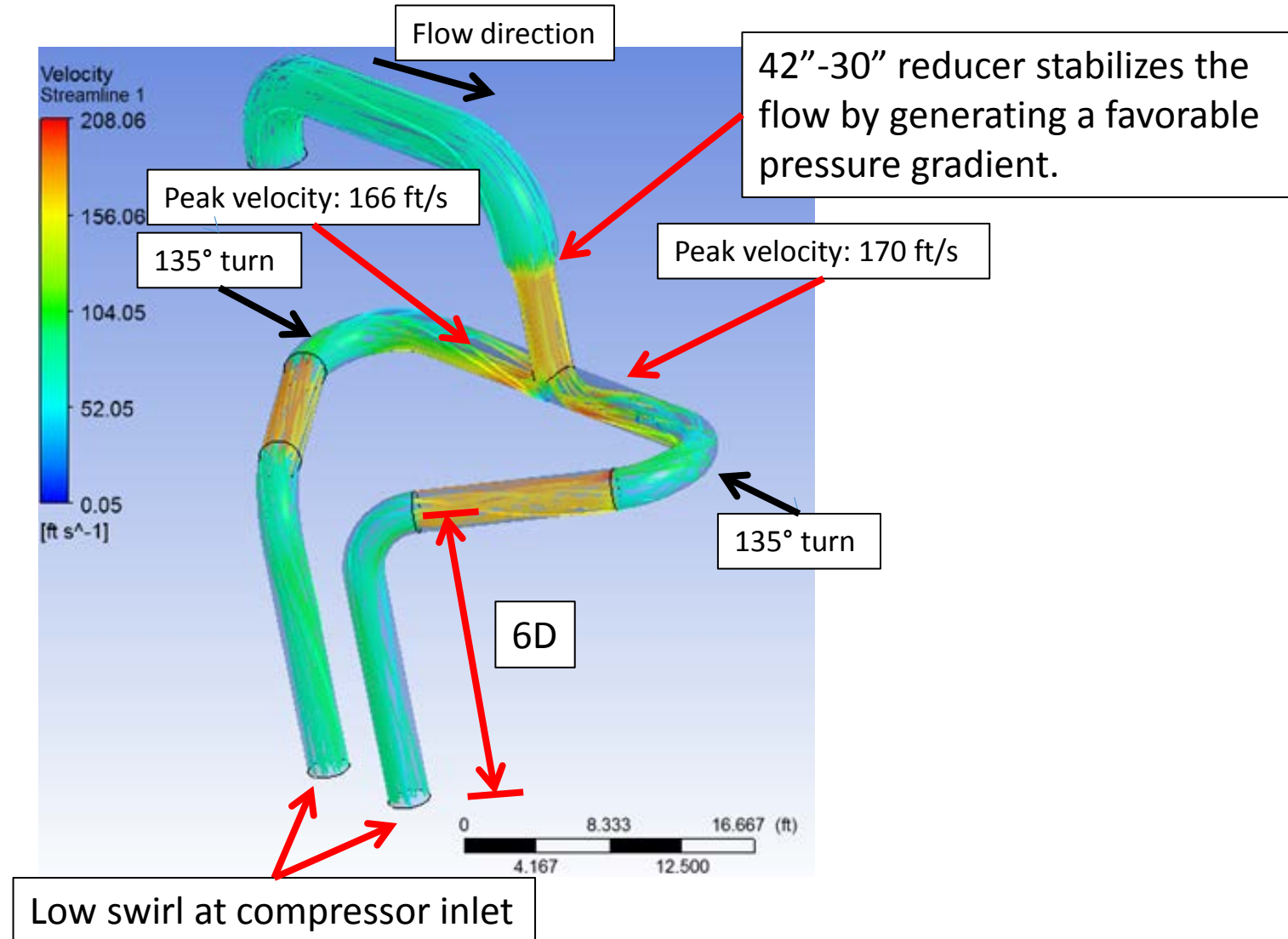

# CFD BASED PIPING ANALYSIS - Results

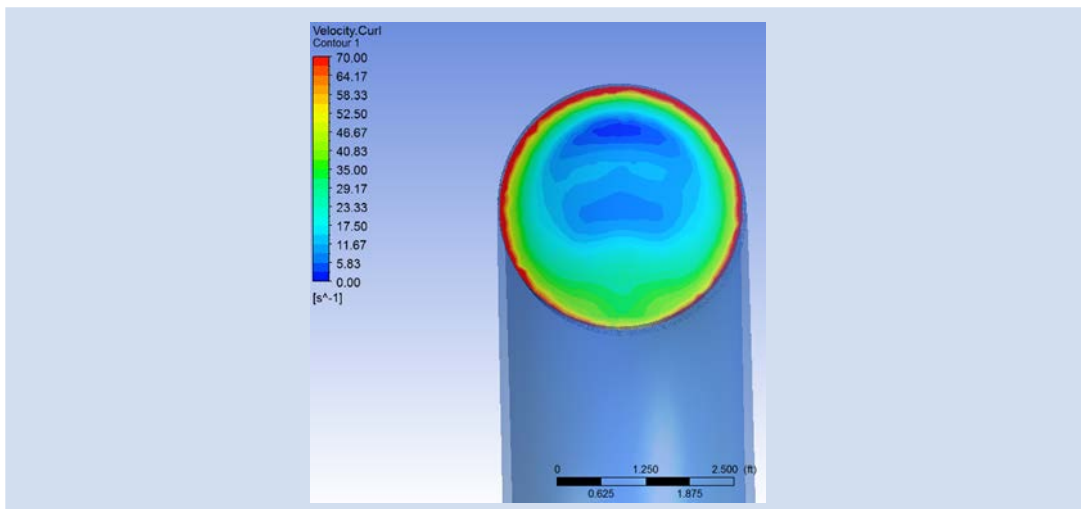
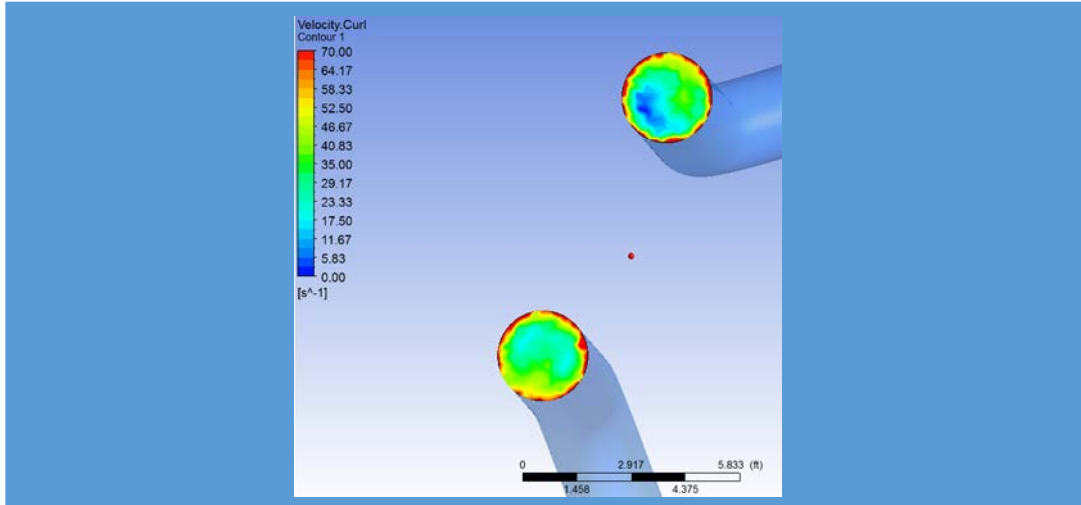

## *Vorticity*

- Peak vorticity near the walls as expected
- Low vorticity near the center of the pipe
  - Peaks at about  $70 \text{ s}^{-1}$ , or 0.01% of the peak value for the entire domain.
- For purposes of comparison, the vorticity contours in the top horizontal section of the pipe are also shown
  - Vorticity values at the compressor nozzles are not very high
  - Flow has very little swirl

# CFD BASED PIPING ANALYSIS - Results

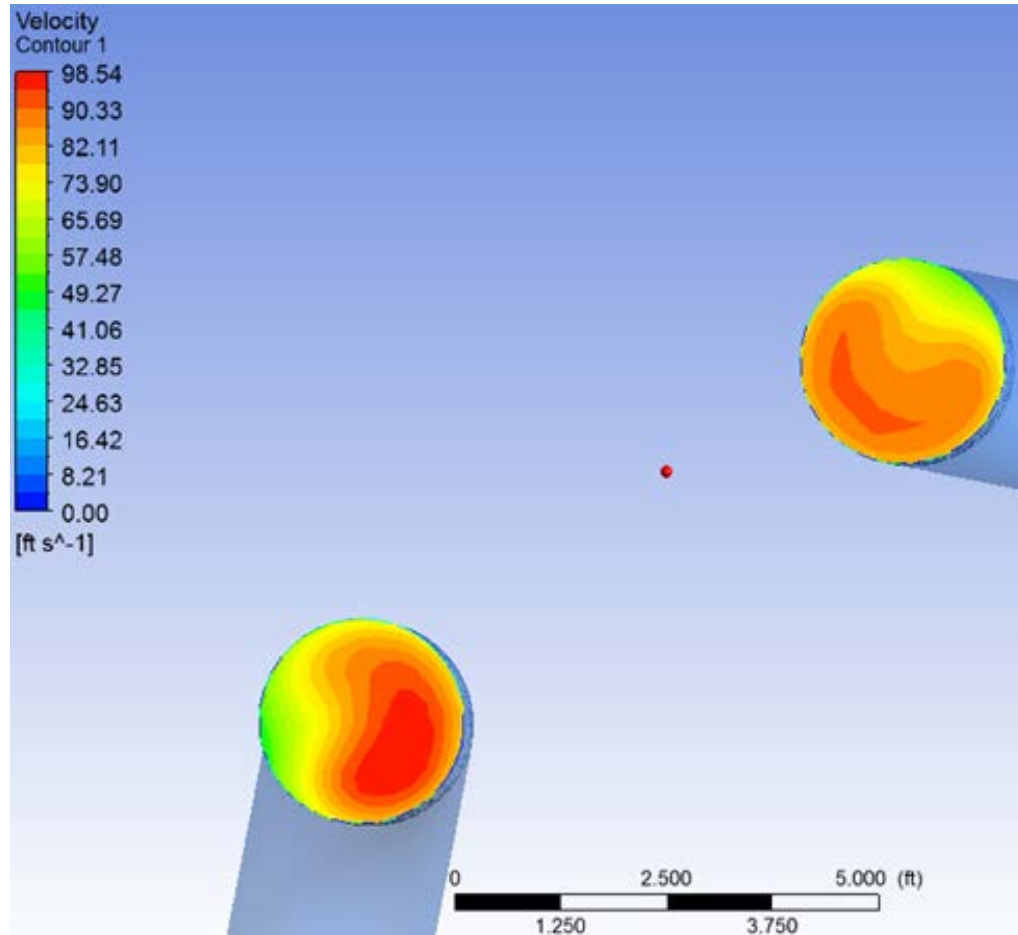

## *Flow Velocity*

- The velocity contours show some distortion but flow is relatively uniform.
- Distortion is minimal and not detrimental to the compressor's performance
  - No excessive swirl
  - No signs of more harmful phenomena such as separation
- Mean flow velocities at compressor nozzles: 83.9 ft/s and 84.7 ft/s
- Mean velocity at the exit of the knockout drum: 79.5 ft/s
- These velocities are well below maximum acceptable values.

# CFD BASED PIPING ANALYSIS - Results

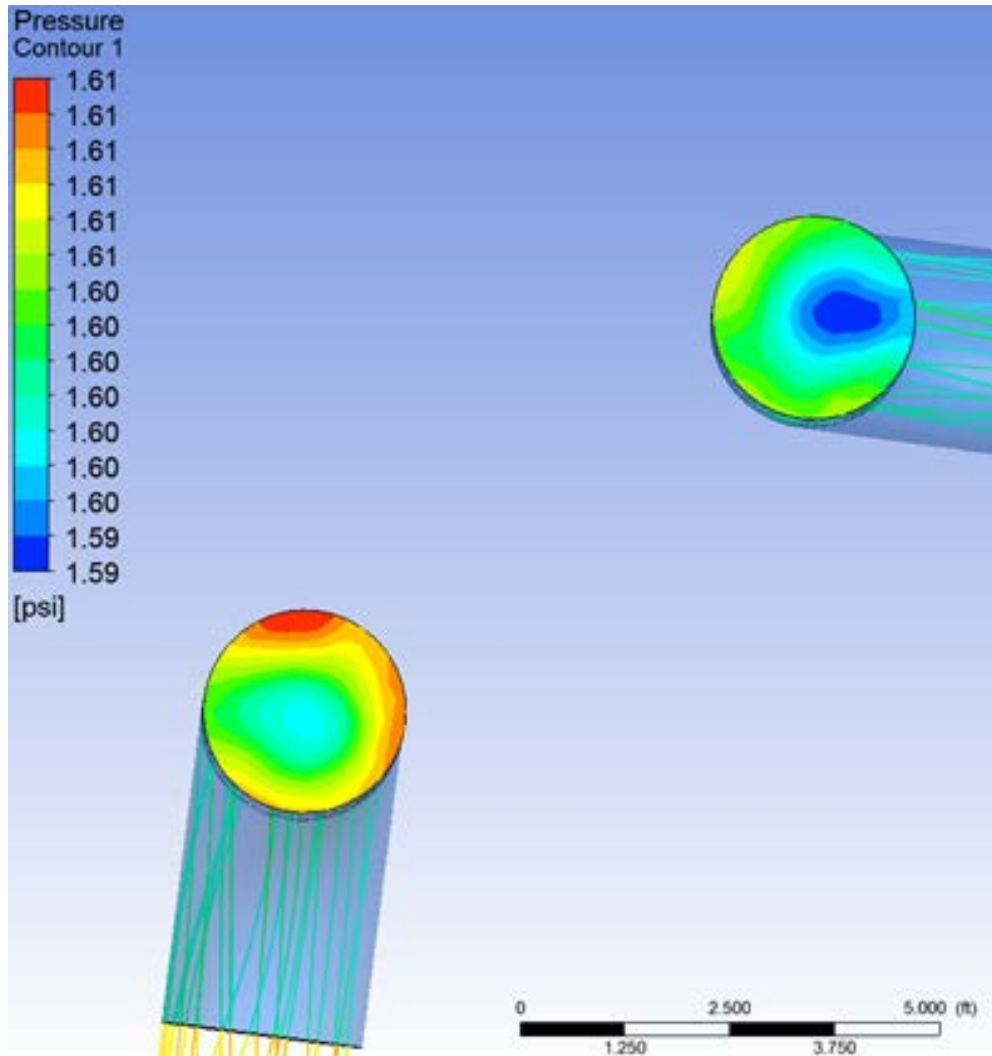

## *Static Pressure Losses*

- Two objectives:
  - Minimize pressure losses
  - Ensure a uniform pressure profile at the compressor nozzles.
- Both nozzles show very little variation across the entire area
- Average pressure difference < 1% (1.609 psi at inlet nozzle 1 and 1.603 psi at inlet nozzle 2)
- Pressure loss through the entire system is 0.3 psi.

# CFD Analysis Results

- EPC Original Piping Design - Analysis found an  $\sim 28\%$  flow unbalance between the two compressor inlets
- Final piping design resulted in an inlet flow unbalance of less than 0.1% at compressor rated flow case.
  - Flow within each inlet pipe was evenly distributed within the pipe cross section without inducing swirl at the compressor inlet nozzle.
  - The model also allowed for the inlet piping to be constructed from standard piping and piping components minimizing system complexity and capital investment.



# Key Compressor Performance Impacts Associated with Non-Symmetrical Flow - Summary

<b>Parameter</b>	<b>28% Deviation</b>	<b>5% Deviation</b>	<b>3% Deviation</b>	<b>2% Deviation</b>
Speed (% Increase from Vendor Calculated)	104.2%	100.7%	100.6%	100.3%
Power (% Increase from Vendor Calculated)	+7%	+1.2%	+0.8%	+0.5%
Stability Margin ((% decrease from Vendor Calculated)	-4%	-1.2%	-0.6%	0%
Overload Margin (% Decrease from Vendor Calculated)	-71%	-13.5%	-0.7%	0%

# Performance Debits – EPC Proposed Piping

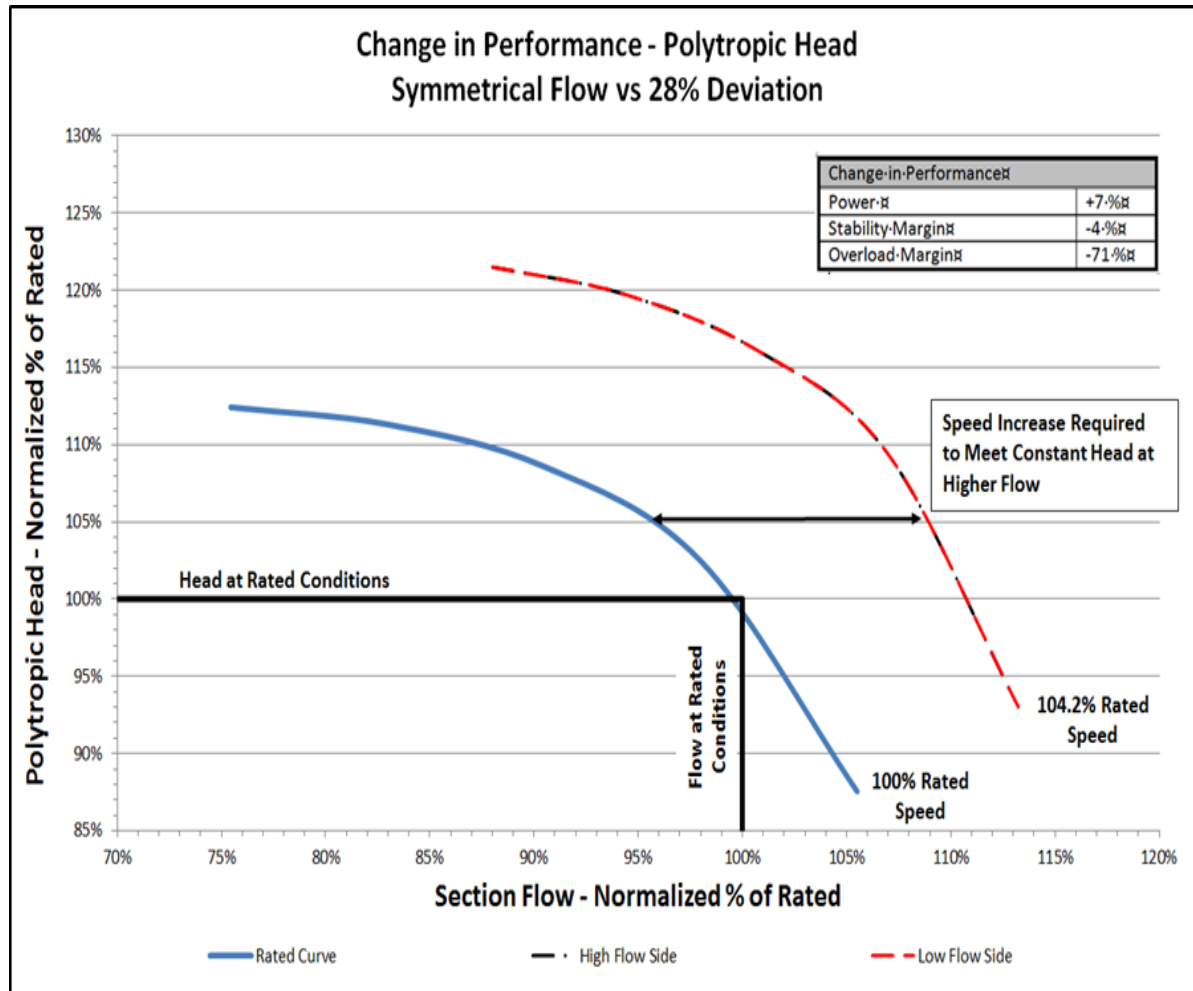

- Power increases by 7%, within 3% of turbine rated power.
- The 7% power increase would cost the refinery  $\approx$  \$150,000 per year based on expected operation ( $\approx$  50% of year).
- The compressor actually tested at +3% power, operation at these conditions would be at the steam turbines rated power.
- The high speed, shortened overload margin, and increased power all indicate potential future operating limitations as process conditions change, turbine steam path wears, condensers foul or water temperatures change.

# Performance Debits – 5% Flow Deviation

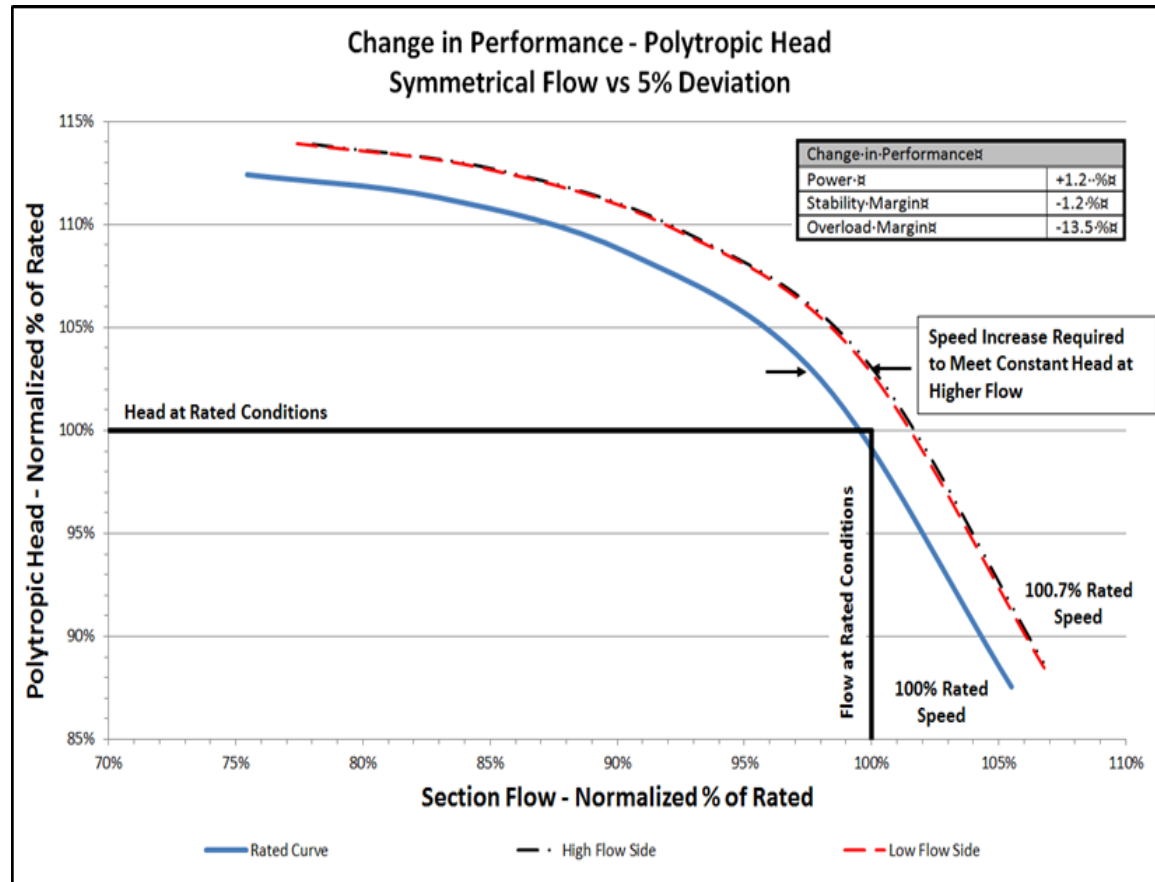

- The 5% flow deviation for configuration (g) resulted in 0.7% speed change, 1.2% increase in power, 1.2% decrease in surge margin, and -13.5% decrease in overload capability
- Analysis indicated that flow deviation less than 5% resulted in minimal to no performance impacts.

# Change in Thrust Load Thrust - Summary

Parameter:	Units	Rated		5% Flow Deviation		28% Flow Deviation	
		DE	NDE	DE	NDE	DE	NDE
Compressor End:	-	DE	NDE	DE	NDE	DE	NDE
Total Compressor Gas Thrust	lbf	(20,418)	20,418	(20,363)	20,123	(20,092)	18,794
Delta Increase in Thrust Loading:	lbf	-		(240)		(1,298)	
Coupling Loading:	lbf	(1,566)		(1,566)		(1,566)	
Thrust Bearing Pressure Loading:	psi	(76.4)		(88.1)		(139.7)	
Thrust Bearing Ultimate Allowable Loading:	psi	250.0		250.0		250.0	
Actual Vs Ultimate %:	%	31%		35%		56%	

Thrust calculated based on Turbo-Lab paper T5 from the 2014 Symposium, Bidaut et al.

# Conclusions

- Ample guidance exists in the literature for single inlet centrifugal compressors with minimal industry guidance regarding the allowable flow deviation for a double inlet centrifugal compressor.
- Equipment manufacturer guidance provided (0% flow deviation) is not practically achieved without complicating the compressor controls with control valves in turn resulting in further system pressure drop and increased capital/maintenance costs.
- The traditional piping design approach is simplistic and does not consider internal flow dynamics as well as other engineering and construction constraints.
- CFD-based piping design approach:
  - Proved to be a cost and time effective solution
  - Aided in the design of a piping system with minimal flow deviations and flow disturbance such as pre-swirl
  - Minimized engineering and field construction costs
  - Allowed construction from standard piping components (minimizing construction costs) and also minimizing overall length of pipe runs.

# Conclusions

- For compressors operating at or near atmospheric inlet conditions unbalanced flow may cause sub-atmospheric inlet conditions, effecting overall operating capacity
- Notable performance impacts in both capacity and energy usage found at flow deviation  $\geq 5\%$  between nozzles; impacts also include:
  - Changes in curve shape with reduction in surge and choke margins
  - Thrust load increase and direction changes that may overload the bearing
- Sub atmospheric inlet pressure complicates the gas seal gas control system.
- An acceptance of some small flow deviations between nozzles can reduce compressor control complexity as well as maintaining operating range and minimizing power requirements.

# Recommendations

- Owner's machinery (compressor) specialist should be involved early in the piping design process to assure compressor performance and reliability are not compromised by inlet piping design.
- CFD-based piping design approach should be applied for:
  - Applications where unique spacing requirements restrict vertical or horizontal space for long straight piping runs and/or piping support structures
  - Compressors with double flow inlets
  - Compressor re-rates where increased flow will be handled in existing inlet piping and compressor nozzles.

# CFD BASED PIPING ANALYSIS – Configurations Summarized

Iteration	Modifications
a	Bring pipe straight from knockout drum to compressor and turn downward, then split with a Y. Reducers are located downstream of the Y.
b	Come out parallel to compressor axis, turn 90° towards the compressor and then turn downward and split with a Y. Reducers are located downstream of the Y.
c	Come out parallel to compressor axis, turn downward and split using a tee. Reducers are located downstream of the tee.
d	Similar to iteration (c) but the vertical run length of the 42” pipe is increased.
e	Similar to iteration (c) but there is only one reducer located upstream of the tee.
f	Similar to iteration (e) but there is one 42”-to-36” reducer upstream of the tee and a 36”-to-30” reducer on each of the final vertical legs.
g	Similar to iteration (f) but the length of the final vertical legs is increased.
h	Similar to iteration (e) but the length of the final vertical legs is increased.
i	Similar to iteration (h) but the length of the horizontal runs immediately downstream of the tee is increased.
j	Similar to iteration (i) but the length of the horizontal runs has been increased
k	Similar to iteration (h) but with mitered vaned elbows at the final downward turn.
l	Similar to iteration (j). The length of the horizontal runs has been adjusted so that the 90° and 45° can be combined into a 135° bend.