

Physical Building Information Modeling for Solar Building Design and Simulation – Annual Report 2011

Dr. Wei Yan, PI, Texas A&M University

Dr. Jeff Haberl, CO-PI, Texas A&M University

Dr. Mark J. Clayton, CO-PI, Texas A&M University

WoonSeong Jeong, Ph.D. Student, Texas A&M University

Jong Bum Kim, Ph.D. Student, Texas A&M University

Sandeep Kota, Ph.D. Student, Texas A&M University

Jose Luis Bermudez Alcocer, Ph.D. Student, Texas A&M University

Manish Dixit, Ph.D. Student, Texas A&M University

NSF GRANT CBET – 0967446

December 1, 2011

Project Activities

What have been your major research and education activities (experiments, observations, simulations, presentations, etc.)?

1 Major research activities

1.1 Research on physical modeling methods

We have investigated modeling of passive solar thermal with Modelica, daylighting with Radiance and DAYSIM, and BIPV with Building Information Modeling (BIM) Application Programming Interface (API). For solar thermal, we have researched on how to model building objects in Object-Oriented Equation-Based modeling language – Modelica by using the LBL Modelica Buildings Library (Lawrence Berkeley National Laboratory, 2011). We have identified modeling methods using Modelica for building geometry, air volume, room configurations, materials, and building components, which are major factors of solar energy utilization in buildings. For daylighting, we studied how to convert building geometry and material information from BIM to Radiance. For Building Integrated Photovoltaic (BIPV), we have researched on how to build solar models in BIM that can calculate solar position and solar insolation.

1.2 Research on BIM simplification methods, BIM topology, and data modeling

We further investigated building object hierarchy and topology in BIM and Modelica-based thermal modeling. Using BIM and its API, we explored modeling and extracting both building object properties (including size, material, and construction data) and building topology, which can represent the connectivity of building objects. We also structured our data modeling method that includes a TAMU

Modelica BIM Package as a bridge between BIM and Modelica thermal modeling. We are currently implementing this data modeling structure.

1.3 Research on linking BIM-OOPM (Object-Oriented Physical Modeling) and integrating P-BIM (Physical BIM)

We reviewed extensively a Modelica-based building thermal library and its example models (LBL Modelica Buildings Library from Lawrence Berkeley National Laboratory, 2011), and evaluated its applicability to P-BIM. We found both advantages and limitations of the library's application in our P-BIM project. The library is the currently most complete building thermal library but still in its early stage of development. We examined various ways to link BIM and LBL Modelica Buildings Library and developed a method that can utilize BIM API and our Modelica BIM Package (under-development) to transfer BIM data to Modelica simulation. For achieving this method, we have experimented sample building models (including a single layer wall, a multi-layer wall, a single room building, a two-room building, and a three-room building) by creating both the BIM models and Modelica Models for each sample. We examined the model data transfer results and simulation results.

In addition, we also conducted literature research on how to utilize Modelica to link BIM and daylighting models. The plan is to use both BIM API and Modelica to integrate building thermal and daylighting (and later BIPV) simulations. Experiments on utilizing Modelica for daylighting and BIPV simulations will be conducted in the next phase of the project.

1.4 Prototyping – P-BIM

a) Solar thermal simulation prototypes

We have further researched the method of our P-BIM prototype using Autodesk Revit, its API and ASHRAE Loads Toolkit, and found the advantages and limitations. ASHRAE Loads Toolkit is a well-developed building load calculation package. However, it is written in procedural programming language (FORTRAN 90) and this presents a significant challenge for us trying to link Object-based BIM and Object-Oriented programming (OOP) language (C#) used in Revit API. In addition, Loads Toolkit is configured to simulate one (1) day and it would need to be completely rewritten to perform an annual simulation needed for P-BIM. We succeeded in implementing selected loads calculation functions in BIM-OOPM that can directly calculate building infiltration and wall conductivity (using Conduction Transfer Functions or CTFs), as case studies, but due to the highly complex transfer of data and functions between procedural and OOP methodologies, the implementation was very difficult with significant research and programming efforts. For example, some subroutines in ASHRAE Loads Toolkit had to be modified manually in order to be called by BIM API methods (functions). Figure 1 shows a sample BIM model and calculation results for this prototype.

The result of conduction transfer function for east wall in the Revit

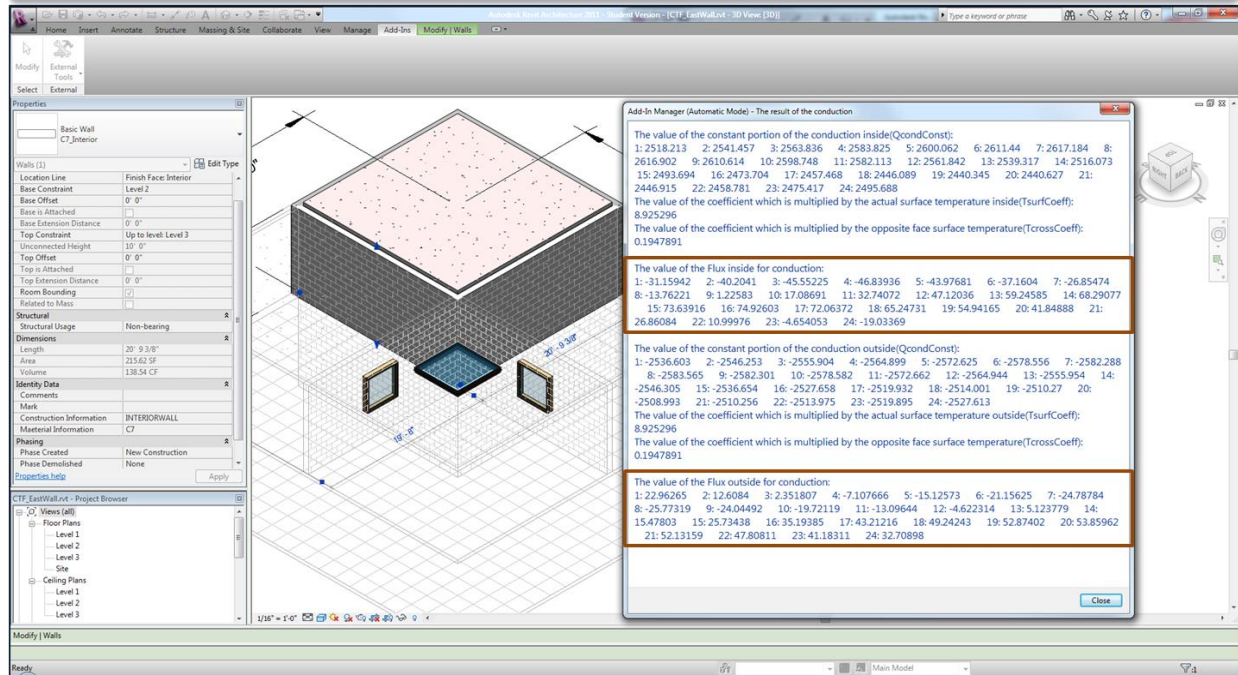

The result of conduction transfer function for east wall from Loads Toolkit output file

FluxInside, -3.1159E+01, -4.0204E+01, -4.5552E+01, -4.6839E+01, -4.3977E+01, -3.7161E+01, -2.6855E+01, -1.3762E+01, 1.2257E+00, 1.7087E+01, 3.2741E+01, 4.7120E+01, 5.9246E+01, 6.8291E+01, 7.3639E+01, 7.4926E+01, 7.2064E+01, 6.5247E+01, 5.4942E+01, 4.1849E+01, 2.6861E+01, 1.1000E+01, -4.6539E+00, -1.9034E+01
 FluxOutside, 2.2963E+01, 1.2608E+01, 2.3518E+00, -7.1076E+00, -1.5126E+01, -2.1157E+01, -2.4788E+01, -2.5773E+01, -2.4045E+01, -1.9721E+01, -1.3096E+01, -4.6222E+00, 5.1241E+00, 1.5478E+01, 2.5734E+01, 3.5194E+01, 4.3212E+01, 4.9242E+01, 5.2874E+01, 5.3859E+01, 5.2131E+01, 4.7808E+01, 4.1183E+01, 3.2709E+01

Figure 1. A BIM model and the results of conduction calculation

[To submit this report using NSF online form, figures will be moved out of the document and uploaded as a separate PDF file]

In addition, we also researched another method and started to develop our P-BIM prototype using Autodesk Revit, its API, and the Modelica-based thermal modeling (LBL Modelica Buildings Library as a case study).

We created a preliminary P-BIM prototype that can transfer BIM data to Modelica building models and directly execute energy simulation in a Modelica development environment (Dymola). The major advantage and challenges of this method are described in Findings #3 below. An initial Modelica BIM Package was built in order to assist in mapping BIM data to Modelica thermal modeling data. Once completed, this approach is expected to allow us to eliminate the redundant, inefficient, and inaccurate process of manually converting BIM data to thermal simulation. For demonstration, we are continuing to perform case studies of heat transfer calculation of the buildings that have more than two rooms. The BIM model and calculation results are shown in Figure 2. This is a promising method and we will continue to research and develop this method in the next phase.

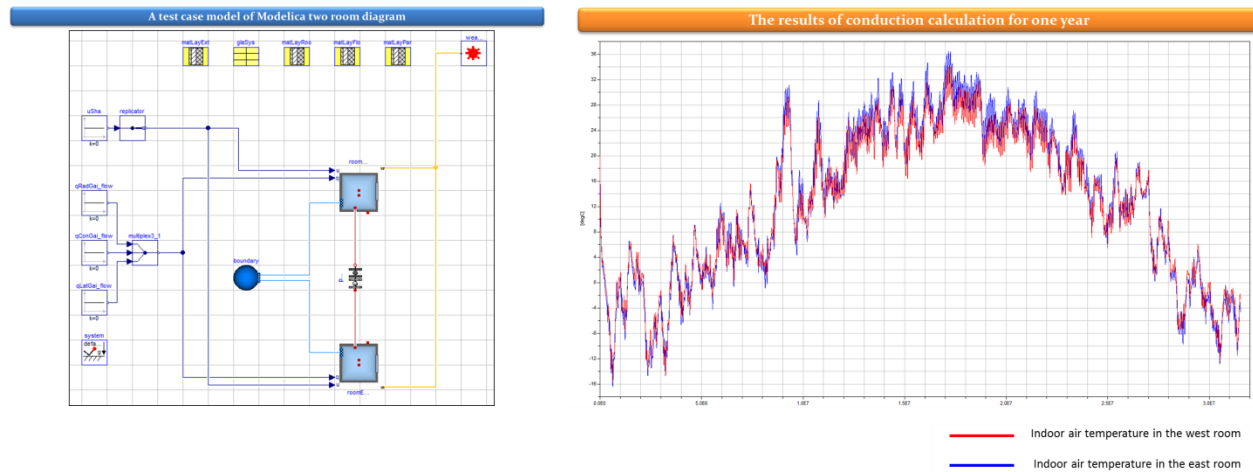
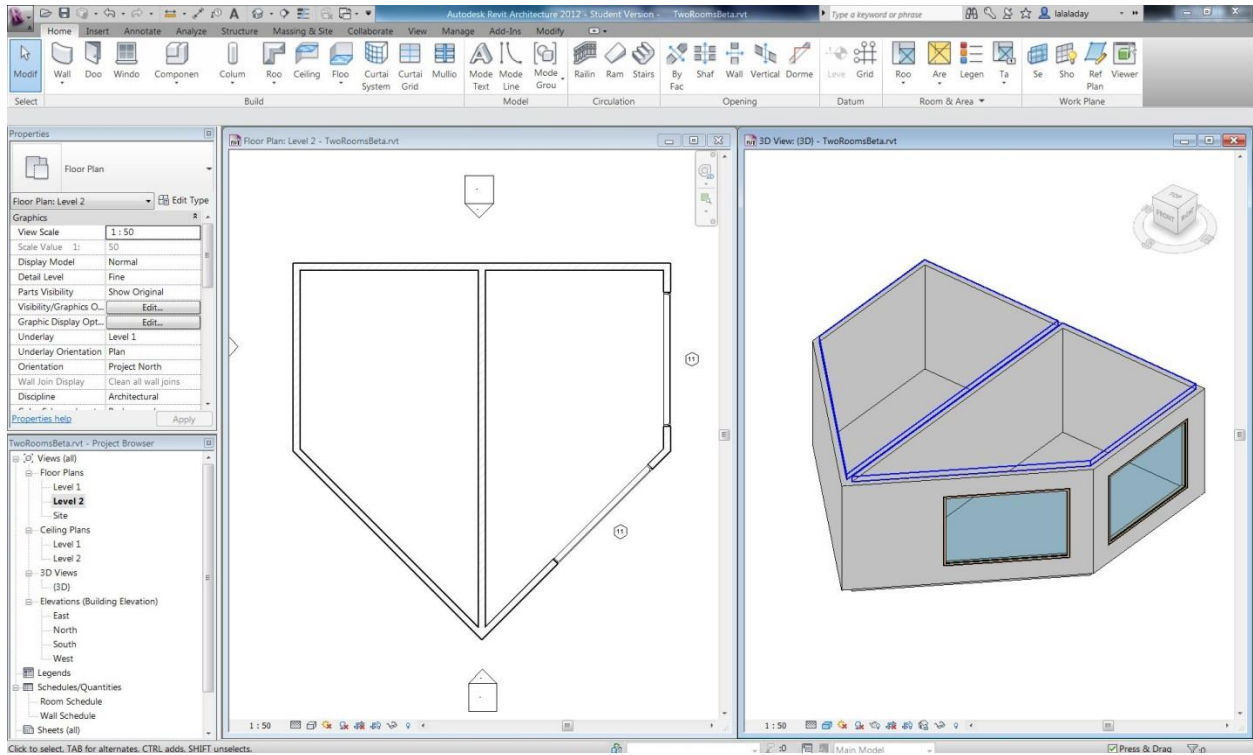

Figure 2. A sample building with two rooms modeled in BIM (top) and Modelica (Bottom).

b) Daylighting prototype

For daylighting modeling, we have investigated a new method of linking BIM and Radiance – the daylighting simulation software tool. We have planned the implementation methods to 1) extract geometry and material information from the BIM model, 2) convert BIM geometry to Radiance geometry model, and 3) translate BIM material information to Radiance material properties such as illumination levels and reflectance. As an example step for the prototype, Table 1 was created to show material properties of Autodesk Revit and Radiance mapping. We are currently working on using BIM API to implement the link between BIM and Radiance. Also we will continue investigating the use of Modelica to integrate the daylighting modeling with thermal modeling.

Table 1. Radiance material properties for BIM (Revit) materials

Revit Categories	Name of the Material	Radiance material type	REVIT COLOR PROPERTIES					RADIANCE MATRIAL PROPERTIES (INDIVIDUAL CHANNELS)			RADIANCE MATRIAL PROPERTIES (AVERAGED)		
			RED	GREEN	BLUE	SPECULARITY	ROUGHNESS	RED	GREEN	BLUE	AVERAGE-REFLECTANCE (R,G,B)	SPECULARITY (0-0.1)	ROUGHNESS (0-0.2)
ASPHALT	Asphalt	Plastic	171	171	171	NA	NA	0.67	0.67	0.67	0.67	0.05	0.10
	Roofing-asphalt Shingle	Plastic	135	135	135	NA	NA	0.53	0.53	0.53	0.53	0.05	0.10
	Site - Asphalt	Plastic	27	27	27	NA	NA	0.11	0.11	0.11	0.11	0.05	0.10
Brick	Masonry - Brick	Plastic	85	48	55	NA	NA	0.33	0.19	0.22	0.23	0.00	0.10
	Masonry - Brick Soldier Course	Plastic	74	38	42	NA	NA	0.29	0.15	0.16	0.19	0.00	0.10
	Masonry - Tile	Glass	72	73	78	NA	NA	0.28	0.29	0.31	0.29	0.00	0.10

c) BIPV prototypes

We have developed a Building Integrated Photovoltaic (BIPV) prototype in the BIM (Autodesk Revit) platform. Our prototype can calculate solar position and determine the amount of solar insolation from given time and location information (Figure 3) with a graphical user interface. We are continuing to develop BIM API that can analyze diffused and scattered components of solar insolation for more precise calculation of solar insolation. This step involves the calculation of the sky clearness index that depends on the atmospheric condition for which we tested the solar insolation model proposed by Kumar and Umananda (2005) and we are developing an algorithm that can be used and tested in locations in the United States. We plan to compare this prototype with PV F-Chart method. We will also research on the use of Modelica for creating PV component models and integrating the PV modeling into thermal and daylighting modeling.

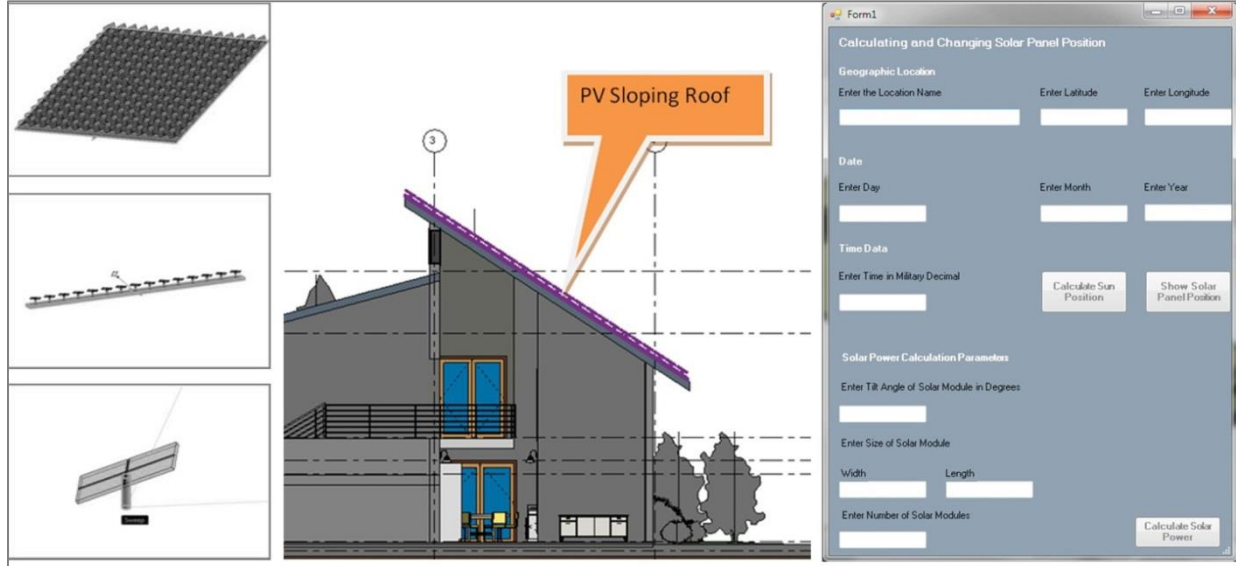

Figure 1. A prototype of BIPV models and BIM API

1.5 Experiments – Solar thermal and daylighting simulations

For integrated solar thermal simulations, we finalized experiments of a high performance office building by using traditional tools (DOE-2.1e, F-Chart, and PV F-Chart) for later P-BIM simulation verification.

The building includes various features of windows, clerestory, photovoltaic panels, solar collectors, etc. (Figure 4). By using the active solar strategies, this solar building can achieve Net-Zero energy consumption. We documented the modeling process, simulation results, and a validation result of test case models that have different configurations of building features.

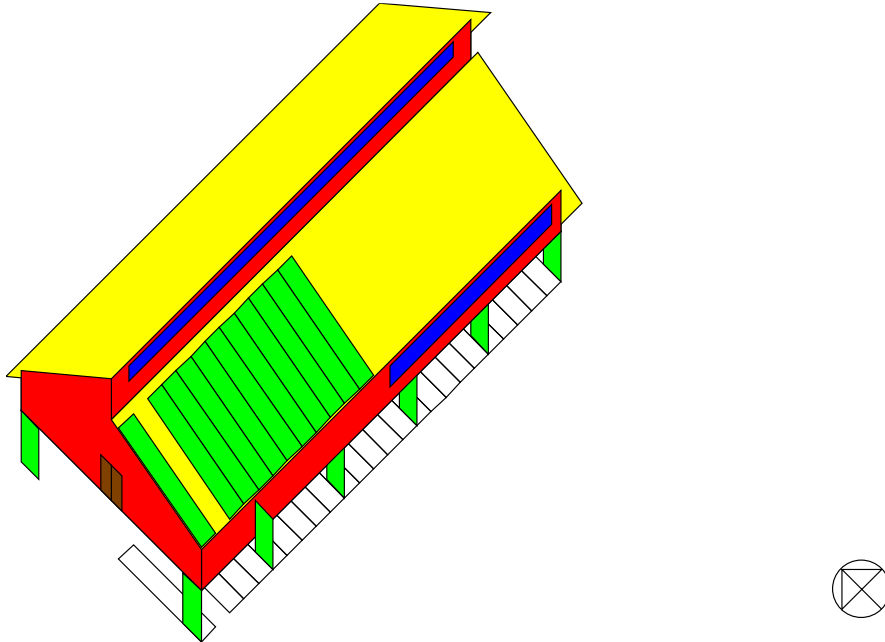

Figure 4. Office building with all solar features

2 Major education activities

Our major education activities include:

- 1) The project provided research subjects and support for Ph.D. studies. Five Ph.D. dissertations in solar building design, daylighting simulation, BIM for urban design, building data modeling, and building embodied energy are in progress. These dissertations are closely related to this project.
- 2) Graduate level Directed Study courses in related topics are offered to students working in this project.
- 3) All of the five students working on this project have taken or are currently taking the graduate Building Energy class taught by Dr. Jeff Haberl and BIM class taught by Dr. Wei Yan.
- 4) Students have attended weekly project meetings with faculty members, in which the students present their research and dissertation work that is related to the project.
- 5) Students have attended teleconferences with Lawrence Berkeley National Laboratory (developers of the Modelica Buildings Library) for collaborative research.

Major Findings

What are your major findings from the activities identified above?

Our major findings include:

- 1) We finalized the document that describes benchmark results of the high performance office building model with various configurations of building features. Through the simulation and preliminary analyses, we achieved reasonable simulation results that can be used for the development of integrated P-BIM simulation.
- 2) We found that there are different structures and modeling concepts between BIM and energy simulation tools, which can make integrating P-BIM very complex. For example, ASHRAE Loads Toolkit, written in procedural programming language FORTRAN, performs loads calculations by using a large number of subroutines that reads building data from an input file multiple times during the calculation (while the ideal situation would be reading the data once into memory and use them in calculation when needed). In addition, some pre-calculated values were hard coded in either subroutines or input files; therefore, accessing and managing building data of energy models are highly complex.
- 3) We found that the major advantage of using BIM-Modelica method is that both BIM (Revit) API and Modelica modeling are based on OOP, and a link between them can be established with a more direct method that maps objects to objects and topology to topology. However, there are significant differences in terms of the semantics and ontology used in BIM and Modelica thermal modeling (one is specific for architecture domain and the other for engineering domain). For example, building components are categorized by the types of boundary conditions that determine algorithms used in energy simulation, while they are categorized as objects such as walls, slabs, etc. in BIM. Even if two slabs have the same material configurations in BIM, different energy simulation calculations may be needed according to the conditions below the slabs. For example, the slab on the ground involves earth-slab conduction heat transfer, whereas the slab above ground causes air-slab convective heat transfer. The understanding of differences of the data modeling and data access mechanisms will help integrate BIM and energy simulation so that inefficient and error-prone process for managing input files in the current energy simulation tools can be substituted by more organized, structured, efficient, and reliable access of BIM data. In addition, we have also found that when we build Modelica models based on LBL Buildings sample models, there is a need to add a convergence algorithm into the simulation.
- 4) The P-BIM prototype demonstrated that the P-BIM methods and algorithms can extract building data from a BIM model, convert BIM data to what the simulation engine requires, and pass the information to energy simulation models. Different granularity levels of building energy simulation can be conducted in P-BIM, through either calling subroutines like ASHRAE Loads Toolkit or executing Modelica thermal simulations directly from a BIM model. Moreover, building parameter values of energy models can be modified from the BIM interface. This way, BIM becomes a user

interface for building energy simulations. Planned for next phase, simulation results should also be monitored in the BIM interface and the feedback can be used for design changes to close the design-simulation loop, which is currently open.

- 5) The preliminary P-BIM prototype for BIPV demonstrated that the P-BIM methods can perform PV energy calculations within the BIM platform. By using BIM API and parametric modeling in BIM, interactions between BIM models and PV calculation can be achieved. The BIM models provide information for PV calculation, and the results can be used to modify the BIM model parameters for updating the building design.

Contributions

1 Contributions within discipline

How have your findings, techniques you developed or extended, or other products from your project contributed to the principal disciplinary field(s) of the project? Please enter or update as appropriate.

Our findings demonstrated that the new P-BIM methods have the potential to facilitate the integration of BIM and building energy simulation that is expected to assist informed decision-making of solar building design. The findings also demonstrated the potentials of the methods for reducing the interoperability problem that exists between building design models and energy simulation models. In addition, our findings can help provide specifications and guidelines for well-designed software systems that integrate design and simulation for sustainable buildings.

2 Contributions to other disciplines

How have your findings, techniques you developed or extended, or other products from your project contributed to disciplines other than your own (or disciplines of colleagues and associates not covered under "Contributions within Discipline")? Please enter or update as appropriate.

The project is cross-disciplinary in the fields of architecture, building science, and computer science. The contributions of the project help integrate architecture and building science with computer science. In addition, our methods demonstrated that specific domain modeling (in our case, BIM) can be integrated into more general physical simulation (in our case, building energy). In terms of computer science, this research provides a case study of translating one OOP-based model (BIM) to another OOP-based model (Modelica models), with different semantics and ontologies.

3 Contributions to human resource development

How have results from your project contributed to human resource development in science, engineering, and technology? Please enter or update as appropriate.

Our project helped prepare students in architecture and building science for academic and professional careers in sustainable building design and research. The research also motivated some undergraduate students to study BIM and energy related topics at Texas A&M University.

4 Contributions to resources for research and education

How have results from your project contributed to physical, institutional, and information resources for research and education (beyond producing specific products reported elsewhere)? Please enter or update as appropriate.

- 1) In 2010, with the support from the NSF grant and our department and college, we built a new BIM-SIM (Building Information Modeling and Simulation) research and education lab, where both undergraduate and graduate students can work on research projects, among which P-BIM is one of major projects. We installed software and hardware funded by this NSF grant in the lab. We have also set up web-based project collaboration and management systems. In 2010 and 2011, we have acquired software systems including Intel Visual FORTRAN®, Dymola®, and Understand® for the project. The facility, equipment, and software can be used further for research and education in the fields of sustainable building design.
- 2) Our project produced preliminary software prototypes of P-BIM (which can be further developed into a complete prototype), daylighting sample models, PV component models, and solar building test models, which can contribute to the information resources for research and education in solar building design and simulation, as well as general building energy simulation.

5 Contributions beyond science and engineering

How have results from your project contributed to the public welfare beyond science and engineering (e.g., by inspiring commercialized technology or informing regulatory policy)? Please enter or update as appropriate.

The resulting preliminary prototypes, models, and methods, when further developed into more comprehensive prototypes, energy models, and software specifications and guidelines, can be used for creating commercialized software tools for solar building design and simulation. One of the related Ph.D. dissertation research projects – BIM’s application in urban planning, has the potential to inspire urban planning code formation.

Acknowledgement

This material is based upon work supported by the National Science Foundation under Grant No. 0967446. Any opinions, findings, and conclusions or recommendations expressed in this material are those of the authors and do not necessarily reflect the views of the National Science Foundation.