

**INTERNSHIP EXPERIENCE AT GREINER ENGINEERING**

**An Internship Report**

**by**

**KEVIN MICHAEL MAHONEY**

**Submitted to the Graduate College of  
Texas A&M University  
in partial fulfillment of the requirements for the degree of  
DOCTOR OF ENGINEERING**

**December 1987**

**Major Subject: Civil Engineering**

INTERNSHIP EXPERIENCE AT GREINER ENGINEERING

An Internship Report

by

KEVIN MICHAEL MAHONEY

Approved as to style and content by:

---

Dr. W. P. James, Chairman  
Student's Advisory Committee

---

Dr. J. S. Noel, CVEN  
Committee Member

---

Dr. D. N. Little, Jr., CVEN  
Committee Member

---

Dr. D. A. Dubofsky, FINC  
Committee Member

---

Mr. A. V. Herring, GE  
Internship Supervisor

---

Dr. C. C. Nelson, MEEN  
College of Engineering Rep.

---

Dr. M. R. Scott, ONCG  
Graduate College Rep.

---

Dr. C. A. Erdman, Assoc. Dean  
College of Engineering

---

Dr. F. C. Heck, Assoc. Dean  
Graduate College

## ABSTRACT

## Internship Experience at Greiner Engineering

Kevin Michael Mahoney, B.S., University of New Haven;

M.S., University of South Florida

Chair of Advisory Committee: Dr. Wesley P. James

The internship report provides an overview of the sponsoring organization and the engineering assignments undertaken during the internship. The role of the intern and many specific activities are described. The historical and corporate development of Greiner Engineering are discussed including changes in ownership and a recent takeover attempt. The conditions and events leading to initiation of Connecticut's Emergency Bridge Program are summarized. Particular attention is given to legislation, funding and the collapse of the Mianus River Bridge. The role of the CLE as the State's agent is explained. Typical technical and administrative duties performed by the intern during the design and construction phases of bridge rehabilitation and replacement projects are discussed. Various design controls, including: hydraulics, railroad and navigation requirements, maintenance and protection of traffic, geometrics and rights of way are identified. A second internship assignment, preliminary planning and engineering of the Grove Street Extension in White Plains,

New York is described. The project background, consultant's scope and intern's activities are discussed. For both assignments, the role of the engineer is related to the needs of a multiobjective society and insight into the decision making process of public works projects is provided.

## TABLE OF CONTENTS

ABSTRACT .....	iii
TABLE OF CONTENTS .....	v
LIST OF TABLES .....	vii
LIST OF FIGURES .....	viii
CHAPTER I. INTRODUCTION .....	1
General .....	1
Internship Sponsor .....	2
Internship Objectives .....	4
CHAPTER II. BACKGROUND OF EMERGENCY BRIDGE PROGRAM .....	6
CHAPTER III. AN OVERVIEW OF THE CLE .....	11
Background and Organization .....	11
Function of the CLE .....	14
Relationship to Other Parties .....	15
CHAPTER IV. TYPICAL PROJECT PROGRESSION .....	22
Phase I - Evaluation Report .....	22
Phase II - Design .....	24
Phase III - Construction .....	26
CHAPTER V. TECHNICAL DUTIES OF LIAISON ENGINEER .....	28
General .....	28
Hydrology and Hydraulics .....	28
Railroad and Navigation Requirements .....	36
Maintenance and Protection of Traffic .....	39
Geometrics .....	41
Rights of Way .....	43

CHAPTER VI. ADMINISTRATIVE DUTIES OF LIAISON ENGINEER ..	46
Administering State-CE Agreements .....	46
Public Hearings .....	50
Securing Federal Aid .....	53
Processing Construction Contracts .....	59
CHAPTER VII. REPRESENTATIVE BRIDGE PROJECTS .....	62
Bridge No. 01594, Kent .....	62
Bridge No. 00111, Bridgeport .....	76
Bridge No. 00618, Colebrook .....	85
Bridge No. 00761, Milford .....	94
CHAPTER VIII. CIVIL GROUP ASSIGNMENT .....	104
Grove Street Extension Project .....	104
Proposal Preparation .....	110
CHAPTER IX. CONCLUSION .....	112
REFERENCES .....	113
APPENDIX A INTERNSHIP PROPOSAL .....	115
APPENDIX B INTERNSHIP REPORTS .....	127
APPENDIX C INTERNSHIP SUPERVISOR'S REPORT .....	154
<u>VITA</u> .....	157

## LIST OF TABLES

<u>Table Number</u>	<u>Title</u>	<u>Page</u>
1	ConnDOT Hydraulic Design Criteria .....	33
2	Feasible Structural Alternatives and Estimated Costs for Replacement of Bridge No. 01594, Kent .....	72

## LIST OF FIGURES

<u>Figure Number</u>	<u>Title</u>	<u>Page</u>
1	Partial Isometric and Detail of Mianus River Bridge, Greenwich .....	8
2	Location Map, Bridge No. 01594, Kent .....	64
3	Plan and Elevation, Bridge No. 01594, Kent .....	70
4	Alternative Superstructures for Bridge No. 01594, Kent .....	75
5	Location Map, Bridge No. 00111, Bridgeport .....	77
6	Plan and Elevation, Bridge No. 00111, Bridgeport	78
7	Elevation of Above-deck Jacking, Bridge No. 00111, Bridgeport .....	81
8	Section of Above-deck Jacking, Bridge No. 00111, Bridgeport .....	82
9	Elevation of Below-deck Jacking, Bridge No. 00111, Bridgeport .....	84
10	Section of Below-deck Jacking, Bridge No. 00111, Bridgeport .....	84
11	Location Map, Bridge No. 00618, Colebrook .....	87
12	Plan, Bridge No. 00618, Colebrook .....	88
13	Location Map, Bridge No. 00761, Milford .....	95
14	Plan, Elevation and Partial Framing Plan, Bridge No. 00761, Milford .....	96
15	Typical Bridge Section, Bridge No. 00761, Milford .....	97
16	Elevation of Pin and Hanger Bracket, Bridge No. 00761, Milford .....	103
17	Section of Pin and Hanger Bracket, Bridge No. 00761, Milford .....	103
18	Project Area Map, Grove Street Extension, White Plains, New York .....	105



## CHAPTER I

### INTRODUCTION

#### GENERAL

This Internship Report is intended to provide the reader with an understanding of my activities during the period from September 1986 through September 1987. Included in this report are background descriptions of my internship sponsor, the projects to which I was assigned and some of the many activities that I took part in during the internship. Hopefully, this report will provide sufficient information for my advisory committee to determine that the Professional Internship (ENGR 684) has been successfully completed.

The internship included two assignments, this is consistent with the Internship Proposal (1). The first assignment was as a liaison engineer on the Connecticut Department of Transportation (ConnDOT) Emergency Bridge Program. Greiner served as Consultant Liaison Engineer to ConnDOT. The second assignment was as project engineer in the Civil Group. For the most part, this entailed the early development stages of an environmental impact statement and project planning report for an urban

---

This report follows the general style and format of the journals of the American Society of Civil Engineers.

transportation project in White Plains, New York. During the internship, over 90 percent of my time was dedicated to the Emergency Bridge Program.

#### INTERNSHIP SPONSOR

The Internship Sponsor was the Wallingford, Connecticut office of Greiner, Inc. This consulting engineering firm was founded in 1908 by the late John E. Greiner in Baltimore, Maryland. Operating first as a sole proprietorship and then a partnership, the firm was acquired as a wholly owned subsidiary of Easco Corp in 1969. Easco was, and is, primarily a manufacturing concern most widely known as the producers of Sears Craftsman tools. In 1981 Easco sold Greiner, then a 300 person firm, to Systems Planning Corp. (SPC).

SPC was a holding company with ownership of several other professional design organizations. The operating companies were located primarily in California, the southwest, Rocky Mountain, and northeast portions of the U.S. Most of the individual locations operated under their before-acquisition names. Greiner was acquired to facilitate SPC's penetration of the mid-Atlantic and southeast regions and the "big project" market.

Shortly after the acquisition of Greiner, the national economy went into recession and SPC sustained significant losses. Pressure was applied on all operating companies to mitigate this condition. Greiner management quickly came

to resent the corporate oversight which had been all but absent under their nearly autonomous relationship with Easco. SPC changed CEOs frequently. Concurrently, in the interest of creating a national identity, Systems Planning initiated a move to unify all operating companies under some variation of the SPC name. That notion and its CEO sponsor were short lived.

In January 1984 Frank Callahan, President of Greiner, was appointed CEO of SPC. In May 1984 the Board of Directors voted to change the corporate name from Systems Planning Corp. to Greiner, Inc. Within months, all of the operating companies, except one, were doing business under the name of Greiner. Variations of the name and structure (e.g., corporation, partnership) were necessary to conform with individual state laws regulating the practice of engineering.

In May 1986 STV Engineers, Inc. offered to purchase all of Greiner's outstanding common stock for \$18.00 per share (2). Greiner signed a letter of intent with STV. On June 9, 1986 a group of employees offered to buy all outstanding stock for \$19.00 per share. Greiner's directorship terminated the letter of intent thereby prompting STV to sue in federal court.

Efforts of the employee group (primarily upper management) to take the company private were subsequently unsuccessful. In December 1986 the employee group

announced that, despite presentations to over 100 prospective lenders, financing could not be arranged. At this writing, the litigation instituted by STV is still pending.

Today, Greiner has a staff of 1,200 and maintains 32 offices.

From its beginning, Greiner's technical focus has been the planning and design of civil works. Greiner has served as the prime consulting engineer for such projects as: the Pennsylvania Turnpike, Ohio Turnpike, U.S. Marine Corps Base at Camp Lejune, Sky Harbor (Phoenix) International Airport, Orlando International Airport and Space Shuttle Landing Facility at Kennedy Space Center. The Greiner-designed Houston Ship Channel Bridge is currently under construction; when complete, it will include the largest cable-stayed bridge span in North America.

The Internship Supervisor was Mr. Allen V. Herring. Mr. Herring is a registered professional engineer and vice president in charge of civil and environmental engineering for Greiner's Northeast Region.

#### INTERNSHIP OBJECTIVES

As indicated in the Internship Proposal (1) the following objectives were established:

1. Apply my academic training and previous experience in civil engineering to the preparation of designs and

studies.

2. Review and assess the quality of professional engineering services performed by other engineering organizations.

3. Effectively coordinate the activities of peers and subordinates to meet schedule and budget constraints.

4. Develop the communication skills necessary to:

- a. present the results of technical evaluations to parties with varying degrees of expertise,
- b. establish and maintain harmonious relationships with clients and coworkers whenever possible,
- c. convince others of the benefits of modifying their position on an issue.

5. Participate in the project procurement process by assisting in the development of technical and price proposals.

It is intended that the activities described in this report provide the advisory committee sufficient information to assess my attainment of those objectives.

## CHAPTER II

### BACKGROUND OF EMERGENCY BRIDGE PROGRAM

Over the past decade there has been a growing awareness that significant portions of the nation's infrastructure are approaching or have exceeded their useful lives. In 1980 the Connecticut legislature ordered (3) ConnDOT to prepare an evaluation of all State roads, highways and bridges. The condition of each was classified as poor, fair, good or excellent. The department was also required to submit a schedule for providing the restoration of road surfaces and bridges over a ten year period.

As a result of the original evaluation, submitted in January 1981, 3,425 bridges were classified as fair or poor. Three hundred were determined to be severely deteriorated and requiring immediate replacement or rehabilitation (4). Consequently, the Connecticut Bridge Rehabilitation Program was initiated in late 1981 to undertake repair of the most critical structures. It was quickly realized that the ConnDOT staff and capital funding committed to this endeavor were inadequate. By the end of 1981 an additional 220 bridges were classified as less than good. The appropriations for bridge restoration were \$10 million in each 1982 and 1983.

In its regular session in June 1983 the General Assembly passed legislation (5) establishing a Special

transportation Fund. The fund generated revenues primarily from motor fuels taxes; motor vehicle receipts; license, permit and fee revenues and investment income. All resources from the fund were dedicated for highway and bridge reconstruction, rehabilitation, repair and resurfacing. It was hoped that this measure would provide the resources to abate further deterioration and then restore a viable transportation network. On June 28, 1983, several days after the Special Transportation Fund's creation, the three eastbound lanes of the Mianus River Bridge in Greenwich, Connecticut collapsed. Three motorists were killed and three others were critically injured.

The Mianus River Bridge carries the east and westbound Connecticut Turnpike over the river and adjacent tidal flats. For practical purposes, the east and westbound superstructures are separate. Each was framed with two steel plate girders and utilized devices known as pin and hanger assemblies. The pin and hangers suspended a 100' section of bridge deck between cantilevered girders (Figure 1). The piers are skewed at 53°.

Media reports of haphazard inspection and maintenance procedures contributed to heightened public concern as to the integrity of bridges statewide. An investigation of the circumstances surrounding the Mianus failure lead to

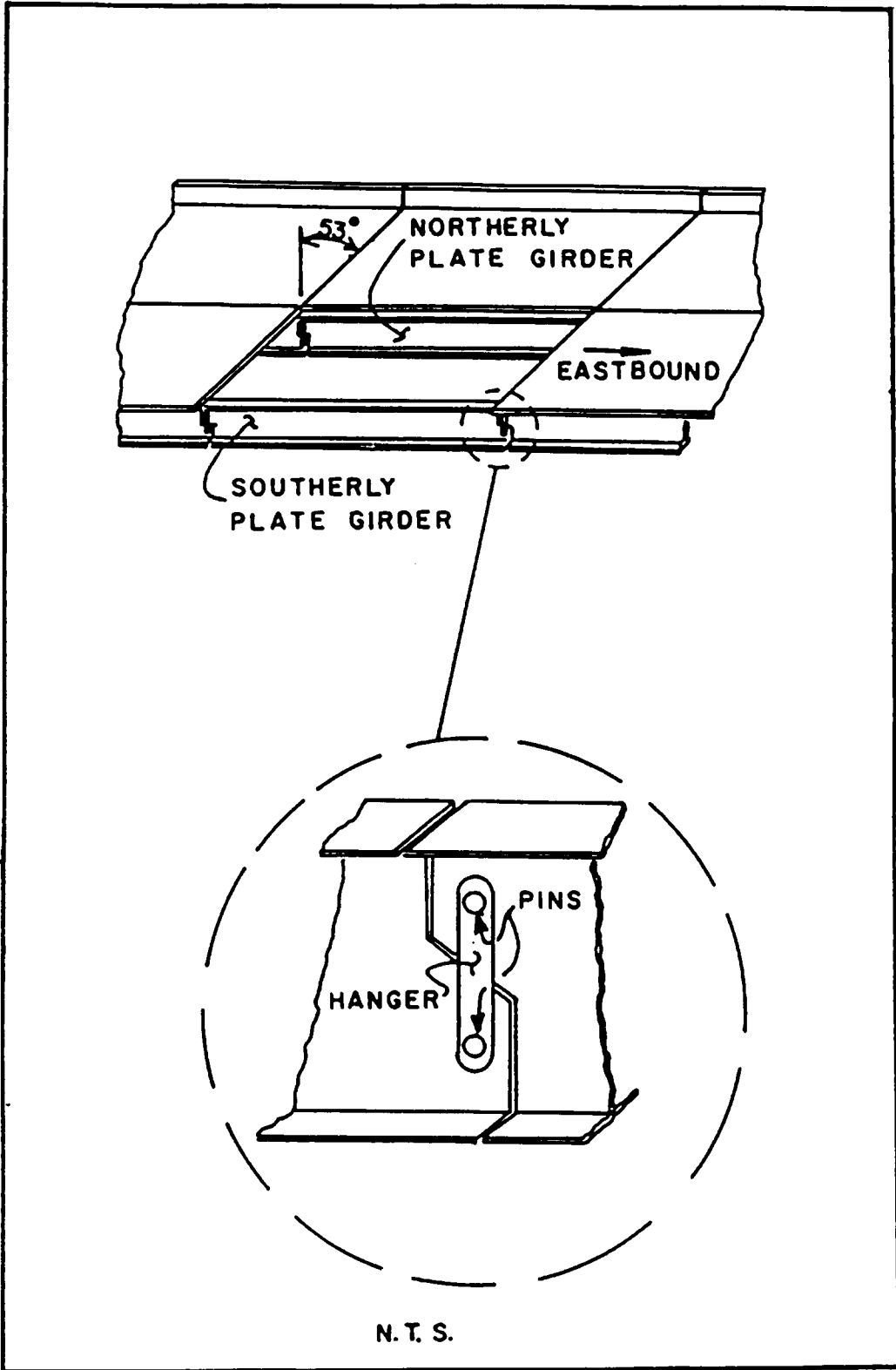

FIG. 1.-Partial Isometric and Detail, Mianus River Bridge, Greenwich



criminal prosecution of bridge inspectors, disciplinary action of administrators and ultimately a comprehensive evaluation and reorganization of ConnDOT's structure and policies.

Concurrently, a number of forensic investigations lead to different and incompatible conclusions. ConnDOT retained the services of Zetlin-Argo Structural Investigations, Inc. Their final report (6) attributed the failure to the design; specifically, pin and hangers on heavily skewed, non-redundant, fracture critical girders. Zetlin-Argo contends that undetected, extensive corrosion of the pins and resultant rust packout were not culpable. Other experts, commissioned by the design consultant and Federal Highway Administration (FHWA) did not concur.

In 1985, the State reached out of court settlements with the victims and their survivors totalling \$7.8 million. The State initiated a lawsuit against the design consultant to recoup the damages for victims and reconstruction expenses; that case was dismissed.

Returning to the period immediately following the bridge collapse a Special Session of the General Assembly was convened in October 1983. At that time funds were authorized to retain 32 consulting engineers to evaluate and pursue designs for 497 bridges. By the end of November 1983, most consultant agreements were concluded and the Emergency Bridge Program was underway.

Although the Special Transportation Fund had been established in June 1983, the revenues being generated were insufficient to support the design and construction activities planned. In its June 1985 session, the General Assembly passed legislation (7) authorizing special tax obligation bonds and additional revenue generators required to fund the \$5.5 billion Infrastructure Renewal Program. The bonds will be retired after a period of 20 years. The 1988 budget for restoration of State bridges is \$109 million.

## CHAPTER III

### AN OVERVIEW OF THE CLE

#### BACKGROUND AND ORGANIZATION

Many federal and state agencies contract with consultant engineers for project investigations, studies, planning reports and designs. Consultants are sometimes used in controversial situations to render a professional opinion that is purportedly free of bias and the influence of involved parties. Most frequently consulting engineers provide a service for which the client does not have the expertise or production resources to perform internally. For the most part, Emergency Bridge Program design assignments were the latter type. Nearly all of these projects could have been successfully completed by ConnDOT's inhouse staff, but not within an acceptable timeframe.

Most large agencies have developed design criteria and administrative procedures for engineering activities; this is true of ConnDOT. Consultants are required, by their contracts, to comply with all such policies and procedures. Traditionally, a unit within ConnDOT known as Bridge Liaison has been responsible for interfacing with consultants involved in the design of bridges for the State. The responsibilities of Bridge Liaison are basically three-fold: to provide technical reviews of the

consultant's work, establish and maintain schedules and administer the State's contract with the consultant.

The Bridge Liaison unit was unable to accommodate the tremendous increase in the number of projects and consultant contracts brought on by the Emergency Bridge Program. Instead of meeting the increased demand by expanding the size of its staff, the State decided that this service would be provided by a private engineering firm. Such a firm is known as a Consultant Liaison Engineer (CLE). Actually, the services provided by a private CLE are far more extensive than those of the Bridge Liaison unit. The CLE's comprehensive project role will be discussed later in this Chapter.

The State contracted with two firms for CLE services on the Emergency Bridge Program, one of which was Greiner. The division of work between the CLEs was based on geography, roughly corresponding to ConnDOT District boundaries. The Emergency Bridge Program is directed by ConnDOT's Manager of Bridge Design who in turn delegates certain responsibilities to his Project Managers (ConnDOT Project Manager), one to each of the two CLEs. The ConnDOT Project Manager is a State employee in residence at the CLE's facility; this individual has a close working relationship with the CLE staff.

Greiner's CLE organization is headed by the CLE Project Manager. Subordinate to the CLE Project Manager are four

two-engineer teams and numerous support personnel. The entire project load is distributed between the four teams; each consisting of a liaison engineer and a bridge review engineer. The support staff; comprised of engineering, technical, administrative and clerical personnel; provide specialized assistance to the four liaison teams.

Each of the liaison teams has five consultants under their direction. By assigning the liaison team to specific consultants, instead of specific projects, effective communications between the consultant engineers (CEs) and CLE are developed. The assignment of individual projects to the various CEs is a ConnDOT function.

The liaison engineer is a civil engineer and the team leader, the bridge review engineer is a structural engineer. The liaison engineer's duties are approximately equally divided between technical and administrative functions, these duties are described in Chapters V and VI of this report. The bridge review engineer's duties are primarily technical. However, due to fluctuations in workload, scheduling and staff considerations, a bridge review engineer may participate in a variety of activities outside her discipline.

Unlike the liaison team, which are continuously involved in a project from assignment through construction, the support staff are involved only at specific times for a particular purpose. It is the responsibility of the

liaison engineer to involve these other parties when appropriate.

The support staff perform such tasks as right of way mapping and acquisition, coordination with public utilities and railroads, preparation of permit applications and specialized technical expertise to supplement that of the individual liaison team members. The support staff also includes a contract administrator and an accountant; their primary duty is to ensure that the CEs comply with the financial accountability requirements of the contract.

#### FUNCTION OF THE CLE

The relationship between ConnDOT and the CLE is one of agency. ConnDOT is the principal and the CLE, the agent. However, ConnDOT is not itself a well-defined, simple being; the activities and interests of its many components are diverse. Therefore we should consider the CLE as an extension of staff, directed by the Manager of Bridge Design and charged with complete project implementation for consultant-designed State bridges.

The specific functions performed by the CLE unit (8), some of which will be discussed in this section, are:

1. Provide administrative control and direction of design consultants.
2. Coordinate inspection survey schedules with towns and media.
3. Prepare and coordinate permit applications.

4. Coordinate utility relocations and prepare necessary agreements.
5. Develop special standard specifications.
6. Provide all right of way services (excluding condemnations).
7. Arrange and conduct public hearings.
8. Coordinate designs and maintenance and protection of traffic with affected towns.
9. Prepare town road detour agreements.
10. Prepare final engineer's estimate of construction costs.
11. Prepare all bidding documents.
12. Prepare bid analyses and award recommendations.
13. Maintain project schedules.
14. Review and approve billings of design consultants.
15. Coordinate shop drawing reviews.
16. Prepare construction change orders.

The liaison engineer is directly responsible for item nos. 1, 2, 7, 8, 10, 11, 12, 13, 14 and 16 and participates in nearly all others.

#### RELATIONSHIP TO OTHER PARTIES

The Office of Bridge Design has been commissioned with the repair or replacement of deteriorated and obsolete bridges. As an agent of the project initiator, the CLE deals with numerous parties who have an interest or are impacted by these projects.

Within ConnDOT, the interest of the Traffic, Bridge Safety, Construction, Hydraulics, Rights of Way, Geometrics and Soils units were sometimes in conflict with each other and/or Bridge Design. In part, CLEs were utilized to circumvent the time-consuming procedures inherent to a departmentalized bureaucracy. On routine matters, concurrence by various ConnDOT units was neither sought nor required. However, on potentially controversial or costly issues, the input or concurrence of various offices was sought. The CLE customarily worked with the various ConnDOT groups to develop mutually acceptable designs. If agreement could not be obtained, the situation was presented to the Manager of Bridge Design for decision.

#### Consultant Engineers

A primary function of the CLE is to direct, review and coordinate the activities of the consultant engineers. The consultants' duties are almost exclusively technical and include evaluation of existing bridges, design and the preparation of contract documents of construction. Because of the CLE's total-project perspective, they establish schedules and the CEs are called upon to meet production deadlines.

The CLE reviews all consultant-prepared evaluations and designs. It is important to note that the CLE reviews; they do not check and/or approve. This distinction may seem trite, but from a liability perspective it is



significant. The State-consultant agreement provides that the consultant's engineer-in-charge sign and seal the drawings. A representative of the CLE must sign the drawings as being "Recommended for Construction." ConnDOT does not review drawings prepared under CLE direction; under the concept of Certification Acceptance, a review by the CLE is construed to be a review by ConnDOT.

The CLE administers all CE agreements with the State. This includes preparation of the actual agreements, review of payment invoices, maintenance of certified payroll and authorization of direct expenditures.

All consultants were required to subcontract with Minority Business Enterprises (M.B.E.) and Women Business Enterprises (W.B.E.). The minimum participation levels are 11 percent and one percent respectively. Subconsultant fees are reimbursable direct expenses to prime consultants. The liaison engineer reviews all subconsultant Work Directives.

The CE agreements with the State for the Emergency Bridge Program are on a cost plus basis. With prior authorization, consultants are paid for the actual wages of their staffs times a multiplier, known as the BFO (Burden, Fringe and Overhead), which may not exceed 2.45. The time spent by principals of the firm is billable at \$35.00 per hour and the BFO is not applicable.

At the beginning of the program (November 1983)

agreements were executed with each consultant for a duration of three years and upset amounts ranging from \$250,000 to \$1.8 million, depending on the CE's project assignments. In order to control the consultant's activities and charges, a system based on Work Directives was utilized. A Work Directive is a worksheet document, prepared by the consultant, requesting authorization to work on and charge for a task up to the monetary amount shown. Work Directives are not authorizations until approved by the CLE. The aggregate of a consultant's Work Directives cannot exceed the contract amount. In those cases where a consultant did not finish his assigned projects within the duration or amount specified in the original agreement, a supplemental agreement was concluded.

Regulatory Agencies

Virtually all project related correspondence and communications between federal and State regulatory agencies was initiated by the CLE on behalf of ConnDOT. The regulatory staffs understood the relationship and for routine and informal matters generally contacted the CLE directly. Formal actions, such as the issuance or denial of a permit would be addressed to ConnDOT with the CLE receiving a distribution copy.

Similarly, meetings were frequently held between regulators and the CLE to resolve differences. Significant determinations or compromising departures

from policy made at such meetings required the confirmation of ConnDOT. The agencies with which the CLE most frequently had contact with were: U.S. Army Corps of Engineers (Corps), U.S. Coast Guard and Connecticut Department of Environmental Protection (DEP).

#### Utility Owners and Railroads

In addition to securing permits, various agreements are often required between the State and other parties such as utilities, railroads and local governments. Such agreements are usually cost-sharing contracts between the parties for project-induced costs. Utility cost sharing formulae are dictated by statute (9) and depend on two parameters: type of highway and utility ownership. Utility expenses related to limited access highways (expressways) are 100 percent reimbursable to the utility owner. For activities involving controlled or unlimited access roads and highways, the utility is reimbursed for 50 percent of their project-associated costs. An exception to the later provision is municipally-owned utilities; 100 percent of their cost is reimbursable, regardless of highway type.

The CLE handles the entire utility relocation process including the preparation, but not execution, of the agreements. Many railroad force account agreements are also prepared entirely by the CLE for execution by the principals. However, because of the inflexible nature of the railroads and extreme costs that are sometimes

associated with these agreements, ConnDOT takes a more active interest in this function. Even in those cases, the process is directed through the CLE.

#### Local Governments, Private Citizens and the Media

Many of the projects involved transportation facilities of importance to the general population. Although, the bridges and their approaches were State-owned and maintained, the support and cooperation of local governments was frequently solicited. The CLE routinely met, corresponded and negotiated with elected and staff representatives of cities and towns. When projects were of a controversial nature, the Manager of Bridge Design sometimes chose to play an active role in dealing with local governments.

Projects often involved additional rights of way. The CLE was responsible for the entire right-of-way process, from map review through acquisition. Naturally, many of the affected landowners were concerned as to the impact of the project on their properties. Unfortunately, at times the impact was undeniably adverse. The CLE was frequently requested to meet with an individual or group of individuals, to explain the project and very often to modify the design. Occasionally, persons or groups other than abutting landowners held strong positions on the proposed project and requested certain features be included or eliminated. Such requests were sometimes accommodated

by the CLE without ConnDOT consultation. In other cases, the petitions of the public were presented to ConnDOT for decision.

Except for field testing schedules which affected traffic operations, the CLE was not authorized to brief the media. Dissemination of information to the media is the province of ConnDOT's Director of Communication. If the Director felt that specific request for information should be provided in detail, he directed the cognizant liaison engineer to be interviewed.

## CHAPTER IV

### TYPICAL PROJECT PROGRESSION

Emergency Bridge Program projects were identified through the State's Structure Inventory and Analysis (SI&A) process. The assigned structures had received a priority designation for restoration or repair. The actual work required for each structure was not established by ConnDOT. The following stages were followed to bring a structure from a deficient status to good or excellent condition:

Phase I - Evaluation Report

Phase II - Design

Phase III - Construction

#### PHASE I - EVALUATION REPORT

An Evaluation Report is prepared by the consultant for each bridge. An early and critical determination is whether the existing structure should be rehabilitated or replaced. This recommendation is based not only on structural sufficiency but also on functional adequacy. In the Chapter VI section, Securing Federal Aid, FHWA procedures regarding this are discussed in detail. Although ConnDOT is not required to apply those guidelines on projects which are entirely State-funded, those procedures are generally used regardless of funding. The Evaluation Report includes a location map, description of

the bridge, sketches, photographs, inspection observations, conclusions and recommendations and construction cost estimate. The recommendation will be for one or more of the following FHWA repair categories:

<u>Repair Category</u>	<u>Description</u>
A	Bridge Replacement
B	Bridge Replacement and Realignment
C	Superstructure Replacement
D	Superstructure Repair
E	Deck Replacement
F	Deck Repair, Waterproofing and Overlay
G	Substructure Repair
H	Paint
I	Bridge Demolition
J	Sidewalk Repair
K	Culvert Repair
L	Bridge Widening
M	Temporary Bridge
N	Bearings and Joint Repair

By September 1986 all Phase I assignments were complete, consequently I did not participate at that stage of the program. Although category selection is made under Phase I, there were numerous cases in which category changes were made during Phase II and in some cases during Phase III. Such retracements are costly.

The project scope is the final product of Phase I and is developed jointly by the CE and CLE. Based on site investigations, review of record drawings and preliminary research, the consultant submits a Project Scope Sheet summarizing his intended Phase II activities. The project may entail not only design of corrective structural measures, but also: approach realignment, hydraulic analyses, geotechnical investigation, topographic surveys, public hearing presentations, preparation of property maps, design of utility relocations and permit backup material.

#### PHASE II - DESIGN

Phase II comprises the largest part of the CE's and CLE's effort. During this phase, a vague repair category description will be refined to explicit detail. Contract documents including plans and special provisions will be developed during this phase along with permits, right of way maps, agreements, construction cost estimates and construction schedules.

Because many of the consultants did not have ongoing assignments with ConnDOT they were unfamiliar with many of the specific policies and design criteria. Therefore, it is most important for the CLE to review and guide the consultant.

For bridge replacements, primary design controls include: hydraulics, railroad and navigation clearances, approach geometrics and maintenance and protection of



traffic. To a lesser extent, rights of way and utilities influence design development. Bridge rehabilitations are most influenced by structure type, maintenance and protection of traffic and clearances. These design controls will be discussed in Chapter V.

For bridge replacements, the consultant will prepare a Structure Type Study after design controls are established. The study should address the most feasible structure types for the particular setting. Initial cost, land impact(s), safety, construction, maintenance and esthetics of each alternative should be considered; a type recommendation is also included.

The Structure Type Study is scrutinized by the liaison and bridge review engineers; consultant type recommendations are never "rubber stamp" approved. It is not uncommon for the CE and CLE to advance different recommendations. Following the CLE review, a meeting is scheduled with ConnDOT for the purpose of making a type selection. Having reviewed the type study in advance and then discussing the project with the CLE at the meeting, the Manager of Bridge Design will normally make a decision at the meeting. Approximately 70 percent of consultant type recommendations are selected for design.

After the structure type is selected, the project is progressed through a series of submittals, each more refined and complete than the previous. All progress

submissions are reviewed by the CLE. Time permitting, review comments are assembled in a standard written format or as marked-up plans for presentation to the consultant. Frequently, the CLE will conduct an onboard review with the consultant's staff to expedite concurrence of the parties and a subsequent submission.

When the CE completes all required tasks, the CLE will accept delivery of the plans, special provisions, bridge certification (for rehabilitations), and construction schedule. The CLE then processes the project for advertising to bidders; award of the construction contract concludes Phase II.

#### PHASE III - CONSTRUCTION

Normally, involvement of designers during construction is limited to shop drawing review. The Emergency Bridge Program is not an ordinary undertaking. When designs and contract documents are developed in a much-compressed schedule, oversights and errors are inevitable. During the construction of bridge rehabilitations, it was frequently discovered that actual levels of deterioration had been underestimated. Occasionally, critical dimensions of existing structures had been incorrectly measured or recorded. At some locations, such oversights could be remedied by extending the use of a repair technique already provided in the plans. In other cases, entirely new designs, including category changes were necessary during

### Phase III.

ConnDOT's construction staff are experts in their realm; however, they are not design engineers. Therefore, the CLE and CEs were often called upon to provide technical assistance during construction. The delineation between the duties of the CE and CLE was particularly clouded during Phase III. In the interest of expediency, the CLE normally handled any development that could be concluded with less than a day's work. Before authorizing construction personnel to field adjust designs, even to compensate for obvious errors, the consultant's concurrence was received and documented.

## CHAPTER V

### TECHNICAL DUTIES OF THE LIAISON ENGINEER

#### GENERAL

The Greiner liaison and bridge review engineers all have backgrounds in design. The eight engineers, including myself, averaged 29 years of experience; five hold the M.S. or M.C.E. and, except one, all are registered.

In general, the liaison engineer will review all civil engineering aspects of a project. When necessary, because of time or individual limitations, the liaison engineer will seek the assistance and counsel of CLE support staff and ConnDOT personnel. Major decisions are reached by presenting the feasible options and a recommendation to the CLE Project Manager and/or Manager of Bridge Design for consideration.

In the ensuing sections of this chapter the various disciplines and issues involved with design development are discussed. To be effective, the liaison engineer should be proficient in several of these areas and understand the implications of all.

#### HYDROLOGY AND HYDRAULICS

Hydraulics are a principal design control for bridges over rivers and streams. A Hydraulic Report is required for all bridge replacements and bridge repairs that in any way affect the hydraulic characteristics of the stream.

The Hydraulic Report, if required, is developed by the consultant in two phases, preliminary and final. The preliminary report addresses the scope, defines hydrologic and hydraulic design criteria and provides an approximate effective waterway. The final report includes all material in the preliminary report plus: frequency-discharge data, water surface profiles and design calculations for sedimentation controls. By reasonable application of hydrologic techniques and hydraulic modeling, a design can be developed to protect the integrity of the structure, its roadway approaches, the stream and riparian lands.

There are two basic design criteria, recurrence interval and maximum allowable backwater. Recurrence interval is a statistical measure relating the magnitude of the event (discharge) to the average period between exceedances. Backwater is an expression commonly used to denote the increase in the water surface profile resultant from a constriction in subcritical flow. The higher water surface elevations represent the kinetic energy converted to potential energy to overcome losses comprised principally of constriction losses and expansion losses. Other losses include those from piers, abutments, eccentricity and superstructure if submerged (10).

Theoretically, constrictions of supercritical flow can cause increased water surfaces upstream. However the influence of this disturbance is local and for practical

purposes it may be ignored.

In highway construction, roadways on embankment are nearly always less expensive than those on structure. Therefore, economy favors constricting the flood plain until the limit of another design control is reached. In this context, design controls are maximum velocity, maximum backwater or impermissible displacement of soils and/or vegetation. Allowable backwater is the prevalent control.

The laws (11,12) and policies governing construction in flood plains make selection of a design criteria a complicated process. Moreover, regulatory agencies are afforded considerable discretion within their jurisdictions; this allows flexibility but detracts from the notion of positive guidance. Written and unwritten policy guidelines may be excepted, modified or terminated with no change in the governing legislation. The following discussion is applicable to my experience on the Emergency Bridge Program.

The first step in selecting an allowable backwater is to determine whether channel encroachment lines have been established at the site. Encroachment lines have been established along all major rivers and some smaller rivers within the State. These lines are mathematically defined in legal descriptions; an index of areas bounded by encroachment lines is available from DEP.

Channel encroachment lines are established by one of

two methods. The first approach was developed by DEP and is basically a mapping of flood plain based on a manual hydraulic analysis using the flood-of-record discharge and a maximum structure-induced backwater of 1'. In other words, a water surface profile was developed using the highest recorded discharges and backwater at bridges as the smaller of 1' or the computed value. The limits of inundation were then plotted on topographic maps; after some adjustment for land use, encroachment lines were adopted. This type of analysis was outmoded by advances in computer hydraulic models in the 1960s.

The second method is to adopt the flood plain boundaries of a Federal Emergency Management Agency (FEMA) Flood Information Study (FIS) as channel encroachment lines. The preparers of a FEMA FIS use hydrologic and hydraulic models to predict frequency-discharge and frequency-stage relationships along the stream. An FIS also includes the establishment of a floodway for flood plain management purposes. A floodway is the watercourse channel and adjacent land areas that must be reserved in order to discharge the base flood without cumulatively increasing the water surface elevation more than a designated height (13). The information contained in previous studies, such as an FIS, are considered as part of the design process.

If a project is within channel encroachment lines the

design criteria is simple, if not rational. Compared to the natural (no bridge) condition, the proposed bridge may not induce more than a 1' increase in the water surface profile for the design discharge. That discharge may be no less than was used to establish the encroachment lines. Additionally, the effective waterway must be at least ten percent greater than the existing.

There are two problems with these criteria. First, the DEP does not entertain discussion of using a reduced design discharge even when it can be demonstrated that such a flow has virtually no chance of being exceeded. This was the case where changes in the watershed and tributary watercourses (e.g., diversions and reservoirs) have been implemented since the flood of record.

Secondly, the notion of arbitrarily providing an additional ten percent of effective waterway does not appear to be a good policy. This criterion requires that existing structures passing design flow, in some cases the flood of record, with minimal backwater be replaced with even larger structures. For large bridges, the cost of this requirement is significant with little or no expected benefit.

If the project is not within channel encroachment lines a more conventional procedure is utilized. The structure is designed to pass a storm of designated frequency with an allowable backwater and a required underclearance. Unless



the structure is within a programmed flood control project area, the allowable backwater is 1' above the natural. The classification system and design criteria shown in Table 1 have been established by ConnDOT (14).

Table 1. ConnDOT Hydraulic Design Criteria

Contributing Drainage Area (square miles)	Class of Hydraulic Structure	Design Storm Return Period (years)	Minimum Underclearance (feet)
< 1	Small	50	--
1 - 10	Intermediate	100	1
10 - 1000	Large	100	2
> 1000	Monumental	Special Study	Special Study

The special study noted for monumental structures may involve requirements established by the Corps, Coast Guard and others.

Whenever possible, hydraulic design is based on gage records. Where no pertinent records are available the discharge is determined by the FHWA Method (15) or the United States Geological Survey (USGS) Regression Method (16). Both methods use area-based regression equations.

The FHWA Method may be used to estimate peak flows with drainage areas of 50 square miles or less. A three-, five-, or seven-parameter equation may be used. However, based on the expected error of the estimate for the 10-year event in Connecticut, effort beyond that required for the three-parameter equation is not warranted. Nationwide, the estimates obtained by the five- and seven-parameter

equations are only marginally more accurate than those obtained using the three-parameter equation.

The USGS Method was developed from the records of 105 stream gaging stations in Connecticut. This method is subject to the following limitations:

1. Drainage areas must be larger than one square mile and less than 1000 square miles.
2. If the watershed is significantly affected by urbanization, adjustment of variables is required.
3. The method should not be used for drainage basins having more than 4.5 million cubic feet of usable storage per square mile of drainage area.

Based on my experience, the FHWA Method yielded consistently higher estimates than the USGS Method. For 50-year and 100-year peak flows, the difference was generally less than 25 percent.

Consultants were asked to use both methods. Barring other methods of estimation such as gage data or FEMA FIS, an average of the FHWA and USGS Methods was frequently used to establish a design discharge.

Whether discharge rates are computed by one of these methods or predetermined by the establishment of channel encroachment lines, a hydraulic analysis is required to demonstrate criteria conformance.

Hydraulic analysis should yield frequency-stage data, backwater resultant from existing and proposed structures

and velocities. Although methods are available to develop the required information, they are not practical. Low cost, readily available hydraulic computer models are far more effective for scenario evaluation. On the Emergency Bridge Program, the following public domain computer programs were used: E431 (17), WSP2 (18) and HEC-2 (19). The first two programs are capable of modeling subcritical and critical flow only; HEC-2 can be used for all flow regimes.

All of these programs are similar to the extent that for channels, each utilizes the standard step method. Computations for this one-dimensional approach assume gradually varied flow. Stage-conveyance relationships for each cross section are computed internally. Beginning from a cross section of known or assumed water surface elevation, the elevation of all sequential cross sections is computed by iteratively balancing the energy relationship between the two sections. For supercritical flow, the progression is downstream; subcritical computations proceed upstream. Beyond their common foundation, the three programs have significant differences in the manner conveyance, velocity heads, losses, obstructions and pressure flow are handled.

The consultants were encouraged to model natural (no bridge) and existing conditions early in the project. As part of the structure type study, the CE can establish a

suitable span arrangement(s) by evaluating several alternatives and the approximate geometric requirements of each. After a structure type is selected the hydraulic design is refined to ensure compliance without excess.

#### RAILROAD AND NAVIGATION REQUIREMENTS

A significant number of Emergency Bridge Program projects involved highway-railroad grade separations. Railroads are bureaucratic, lethargic and expensive to deal with. Railroad coordination is necessary whenever construction activities will take place on or over a railroad right of way. There are three levels of railroad coordination.

The first and simplest level is a project that involves construction activities over a rail right of way but not below the deck of the highway-over-rail structure. For this type of project the construction contractor must purchase additional insurance naming the railroad as the insured.

The second level is a bridge rehabilitation in which the existing clearances are not altered. For this type of project a railroad force account is required. A force account agreement is a contract where the State dedicates funds to paying for services performed by railroad personnel in connection with a State project. Typically, the services provided are engineering, flagging and inspection.

The third level of railroad coordination pertains to bridge rehabilitations affecting clearances and bridge replacements. Coordination involves two separate tasks, determination of clearance requirements and the force account agreement.

The minimum vertical clearance for new over-rail bridges of 22'-6" is established by State law (20). Existing vertical clearances may be maintained for rehabilitated structures if existing abutments are utilized. A minimum horizontal clearance of 8'-0" from the centerline of existing or reasonably-anticipated future track to an obstruction is required. There is sometimes disagreement between the railroads and State regarding the provision for future or relocated trackwork. A clearance diagram showing tracks and all clearance requirements is prepared by the CLE for signature approval by ConnDOT and railroad officials.

All railroad coordination is provided by the CLE and requires a minimum of four months from the time a scope and preliminary design are complete. All force account agreements are prepared by the CLE support staff. The liaison engineer is responsible for including special provisions in the construction contract, providing the consultant with geometric design controls and programming railroad coordination into the advertising schedule.

Activities over navigable waterways are under the

jurisdiction of the U.S. Coast Guard. The limits of the Coast Guards legal authority greatly exceed the practical requirements necessary to regulate navigation. To eliminate the administration of inconsequential watercourses, the Coast Guard Third District has compiled a list of harbors and rivers in which they maintain their authority; all other locations are exempt from regulation.

If a project is within a Coast Guard regulated area, ConnDOT's Early Coordination Procedure is used to determine the extent of regulation. By advising the Coast Guard of the project location, scope and schedule they will determine one of the following:

- a. no further coordination is necessary,
- b. continued coordination is required,
- c. a Coast Guard permit is required.

As a rule, the first determination is made for locations where commercial navigation does not presently exist nor is anticipated but that the Coast Guard has withheld from blanket exemption.

Continued coordination is usually required for projects over actively navigated waterways but where no permanent change in clearances will result. As a result of extended coordination, the Coast Guard may impose restrictions and review authority over construction methods, equipment and schedules necessary to protect marine traffic.

A Coast Guard permit is required for bridge

replacements and rehabilitations that affect clearances. The Coast Guard dictates clearance requirements, they are generally not negotiable. In addition to geometric limitations, navigation lighting, channel markers and structure-mounted staff gages are required. All Coast Guard coordination is the responsibility of the liaison engineer.

#### MAINTENANCE AND PROTECTION OF TRAFFIC

An essential element of every bridge repair and replacement project is the Maintenance and Protection of Traffic (M&PT) Plan. Such a plan is required to provide motorists with safe passage through a construction area. The plan is intimately related to the structure type, site conditions and traffic characteristics. It is imperative that the M&PT Plan be developed in parallel with the geometric and structural design. Too often, seemingly complete designs are rendered useless by a failure to plan for a viable method of temporarily accommodating traffic.

The convenience of the motoring public is a principal consideration in the development of M&PT. ConnDOT is extremely sensitive to public sentiment regarding delays and safety. The M&PT represents a significant cost to the project far exceeding the actual bid items used to implement the plan. Because the contractor is generally required to conduct his operations in a confined work area and at times other than those he chooses, a premium is

introduced to all bid items.

The basic methods used to maintain traffic are alternating one-way traffic, reduction in number of lanes and detours. Alternating one-way traffic is used on two-lane highways with average daily traffic (ADT) of less than 10,000. One lane of traffic is maintained through the work area, vehicles traveling in opposite directions take turns passing through the construction area. For locations accommodating ADT of 6,000 or less and with adequate sight distance across the work area, stop sign controls are used; for higher volumes and insufficient sight distance temporary signalization is utilized.

On expressway and other multilane highways it is sometimes possible to restrict traffic operations to less than the full number of lanes. The minimum number of lanes can be established by allowing a maximum load of 1400 vehicles per hour per lane. Design volumes should be obtained from direct counts if possible. At some locations, the available capacity and relatively low volumes allow project-long reductions in the number of lanes. Such cases are rare. Most often, reductions can be tolerated for short durations during seasonal or daily off-peaks periods. On several projects, the volumes dictated that all operations requiring lane reductions be conducted at night.

Detours involve rerouting all traffic from the segment



of the highway containing the project onto other existing roads. This approach is inexpensive and conducive to expeditious construction. However, only when site conditions impose too much restraint on the contractor's operations will a detour even be considered. The possible increase in response time of police, fire and emergency medical treatment along with extending school bus routes and commuter paths are deterrents to frequent use of detours. Detours are used most often in urban environments where the transportation network is dense and work areas restrictive.

Before a detour could be implemented, an acceptable alternative route for all types of traffic would have to be identified. Preferably, the detour route will include only State highways; however, if this is not possible local roads may be used. If local roads are needed for the detour, their adequacy in terms of geometry, width, markings and structure should be evaluated. Assuming a local road is identified for use as a detour, the liaison engineer should contact the city or town owning the road and obtain their permission through a detour agreement. Detour agreements are formal contracts, prepared by the CLE and executed by the State and local authority.

#### GEOMETRICS

Substantial revision of horizontal and vertical alignments were not generally included in projects. That

type of improvement would require extensive off-structure involvement and that was considered beyond the realm of the Emergency Bridge Program. However, in a few cases, circumstances were compelling enough to consider and implement much broader scopes than rehabilitation or replacement on existing alignment. Those projects were among the most challenging and interesting.

ConnDOT has a Geometrics Committee responsible for policy development and publication of the Highway Geometric Design Standards (21). The committee has adopted, with some exceptions, AASHTO's 1984 Policy (22). The most relevant exceptions are clear zone requirements and methods of determining intersection sight distance. ConnDOT is more conservative regarding clear zones.

The AASHTO policy on intersection sight distance is generally more conservative than ConnDOT's. The latter is based on field-measured, time-distance relationships for passenger vehicles. ConnDOT does not consider two seconds of driver perception/actuation time warranted.

In consideration of icing conditions, ConnDOT uses a maximum superelevation rate of 0.06 feet/feet for rural environments; a maximum of 0.04 feet/feet is used for urban conditions.

Because many of the existing approaches were geometrically nonconforming and projects were usually limited to the immediate vicinity of the structure, final

designs frequently included substandard features. Designers often found themselves with the dilemma of choosing to provide adequate sight distance at adjacent drives or conforming rail/barrier systems at the structure. An unwritten policy of providing protection for mainline traffic at the expense of the abutters was adopted, provided the project did not decrease sight distance.

For bridge replacements, the geometric development must be made in consideration of numerous and sometimes conflicting considerations. Construction methods, M&PT, rights of way, hydraulics, clearance requirements and structure type are all affected by geometrics. The liaison engineer is responsible for review of the consultant's preliminary plans, exceptions to minimum design standards should be identified during that review.

#### RIGHTS OF WAY

Acquiring rights of way and easements from the owners of land abutting a project is often a lengthy process. The procedure for such acquisitions is largely dictated by state statutes (26,27) and administrative orders.

The consultant is required to conduct a title search of all abutting properties and identify existing rights of way, easement and property lines. As the design is refined, the extent of required takes can be determined. Because the acquisition process is a long-lead item, the

liaison engineer should encourage the CE to make that determination as soon as possible.

When the required information is available, the consultant will prepare property maps for all affected parcels. The map will identify the proposed acquisition in relation to the project's horizontal control and existing rights of way. The map must be certified by a Land Surveyor registered in the State of Connecticut. Property maps are reviewed by the liaison engineer for accuracy and consistency with prevailing policies.

Upon completion of the maps, they are turned over to an independent appraiser who determines the value of the land being acquired or project-related damage. The appraiser's recommended award (appraisal) is reviewed by ConnDOT, if they concur, control reverts back to the CLE for the negotiation process.

The CLE negotiator contacts affected landowners and tenders a check in the amount of the appraisal. In exchange for the payment, all property owners of record must sign an instrument accepting compensation as equitable for the damages or acquisition. If the property owners willingly accept the offer, the process is essentially complete and the liaison engineer has no further participation.

However, in many cases landowners are concerned or displeased by the impact of the project on their

properties. The negotiator will request that the liaison engineer call or meet with the property owner and discuss their concerns. In some cases, property owners merely want someone to explain the project and the plans; others request that the project be totally revised. Most requests for design revisions can be acted on by the liaison engineer; controversial matters and scope changes should be discussed with ConnDOT and/or the consultant.

If a "friendly acquisition" cannot be achieved and ConnDOT will not consider redesign, the property will be condemned under the State statute (27) granting the Commissioner of Transportation the power of eminent domain.

## CHAPTER VI

### ADMINISTRATIVE DUTIES OF THE LIAISON ENGINEER

As previously indicated, the liaison engineer provides civil engineering direction to projects and tends to an array of administrative functions. Several of these recurring tasks are described in this chapter.

#### ADMINISTERING STATE-CE AGREEMENTS

##### Work Directives

Fiscal control of consultants is an important duty of the CLE. As the State's agent, the CLE monitors consultant progress and monetary charges. The system of Work Directives, briefly described in Chapter III, was used to control levels of authorized expenditure.

The authority to approve or disapprove Work Directives is the only real leverage that the CLE has with consultants and it yields less than positive control over their activities. Based on an unfortunate experience, I initiated a practice of speaking to the CE regarding each Work Directive before preparing an official response. Although significant background information and conclusions were documented in writing, these conversations proved far more candid and informative than could be expected from correspondence.

The Work Directive system utilizes the convention of dividing a project into Phases I, II and III. A separate

Work Directive for Phase I and another for Phase II was prepared for each bridge. A single Phase III Work Directive included all bridges assigned to a consultant.

A Phase I Work Directive is determined based on the type, length, accessibility and apparent condition of the structure. The need for special rented equipment and laboratory testing of core samples should be anticipated.

Based on a project scope determined at the conclusion of Phase I, the consultant submits a Phase II Work Directive for each bridge. The techniques used by CE project managers to estimate their required effort vary considerably, most are quite liberal. The liaison engineer reviews all Work Directives for projects under his direction and if necessary negotiates with the consultant before making a concluding recommendation to the CLE Project Manager; his action is binding.

It is important for the reader to understand that an approved Work Directive for specified tasks is not a contract requiring the consultant to complete the tasks for the amount shown. Although it is intended that the work directive amount will be sufficient to complete the associated work, this "intention" is not legally enforceable. In fact, the Work Directive does no more than authorize the consultant to incur reimbursable costs in connection with the specified tasks.

Actually, the CLE has the authority to unilaterally

reduce or increase a consultant's Work Directive and approve it as-adjusted. Although this is fairly common practice by liaison engineers I feel it breeds resentment by the CE and is ultimately counterproductive.

On those occasions when I received a Work Directive that I considered inappropriately high and was not convinced by the consultant's explanation, I asked that a new Work Directive be submitted and suggested a monetary amount. To a certain extent this exercise includes the CE as a cooperating party and gives her some incentive to achieve a mutually-selected target. This was successful in some cases but on other occasions Work Directives developed in this manner were subsequently modified to increase fees.

One of the most difficult situations that a liaison engineer must contend with is a consultant who continually requires Work Directive Modifications. This is particularly unpleasant if the cause of the overruns is mismanagement and lack of technical proficiency. As these situations presented themselves, the liaison engineer and CLE Project Manager engaged consultant management in long dialogue of contributing and mitigating factors. At the core of each such dispute were essentially the same set of conditions; a valid cost-plus agreement was in force, authorized levels of effort were exhausted and the project was not complete.

Although the CLE has the authority to issue Work



Directives up to the contract amount, that course avoids the issue of justification. In all cases with which I am familiar, expediency was sufficient justification. The pressure of advertising schedules and potential litigation by disgruntled consultants prompted ConnDOT to totally expend contract amounts and supplement for money if necessary to have assignments completed.

#### Invoice Review

Under their agreements with the State, consultants were required to submit invoices on a monthly basis; most did not. Given the extensive reporting requirements of ConnDOT, the consultant's reluctance to conform was understandable. So distasteful was the task of assembling an invoice that several consultants submitted invoices at a frequency of less than one per year. Most consultants submitted invoices without regularity but at an average interval of two to three months.

Once the invoice arrived at the CLE it was subjected to review by the project accountant, liaison engineer and CLE Project Manager. The accountant performs a detailed check of arithmetic, conformance to the consultant's certified payroll and authorization for direct expenses. The accountant also verifies that invoice charges for each individual bridge are less than the amount authorized by Work Directive. The accountant has the authority to delete unauthorized payroll and out-of-pocket expenses and correct

arithmetic errors with appropriate adjustment to the invoice total. The invoice is then forwarded to the liaison engineer.

Based on his insight of the individual projects and the consultant's progress, the liaison engineer reviews the invoice from a different perspective than the accountant. The liaison engineer should be familiar enough with the consultant's staff and operation to identify questionable personnel and direct expenses. The liaison engineer also monitors the consultant's progress toward M.B.E and W.B.E. participation goals. The percent of goal attainment should not be significantly less than the consultant's aggregate percent complete.

An important feature of the invoice is the consultant's estimate of the aggregate percent complete. Before an invoice can be approved for payment, the liaison engineer must concur with the invoice estimate. If the liaison engineer does not initially concur, she will request the consultant to submit supporting materials such as plans, computations and maps. The liaison engineer will then approve or disapprove the invoice. If the liaison engineer concurs, the invoice is forwarded to the CLE Project Manager who must also approve the invoice for payment.

#### PUBLIC HEARINGS

Certain Emergency Bridge Program projects, primarily bridge replacements, required public hearings. Federal aid

projects that require right of way acquisition, impact historical or recreational property or require an Environmental Assessment under the National Environmental Protection Act require public hearings. For projects that are entirely State-funded, an opportunity for public hearing is afforded as part of the DEP permit application process. Occasionally, ConnDOT elects to hold a public hearing or public information meeting even though none is required; such forums are generally conducted because of widespread interest in the community.

When it has been determined that a public hearing will be held, a meeting is arranged between the CLE and chief elected official in the community where the project is located. At the meeting, the liaison engineer will brief the town official(s) on the project history, feasible alternatives under consideration and tentative schedules. The support of the local official is solicited.

The mayor or first selectman is likely to know which parties will have a strong interest in the project and what their positions will be. Such insight is helpful in preparing for the hearing. Also at this meeting a preliminary date and time of the hearing is established. The local official is requested to act as host for the public hearing and arrange for a public building as the hearing location.

After finalizing arrangements for the hearing, the

liaison engineer prepares, distributes and arranges for the publication of legal notices and news releases. The format and timing of legal notice publication are dictated by federal regulations and State law (28).

The liaison engineer prepares the Presentation of Alternatives section of the hearing. Included in the presentation are the need for the project, the alternatives considered (including the null alternative) and probable project impacts. Typically, the narrative is supplemented by graphic displays prepared under the direction of the liaison engineer. Approximately 10 days before the hearing date, a dry run is held with ConnDOT. At this time, representatives from various units of ConnDOT critique the presentation. If required, a second dry run is held after revisions are made.

At the actual hearing, the liaison engineer is present to answer questions. The CLE Project Manager makes the formal Presentation of Alternatives which is essentially a verbatim reading of the prepared narrative into the record.

During the comment and question period of the hearing ConnDOT officials sometimes make commitments that directly affect design. Obviously, the liaison engineer must remain cognizant of those commitments and ensure that they are included in the project.

Following each public hearing, a 30-day period is provided to allow any interested party an opportunity to

comment or forward questions on the proposed project. Each such question or comment must receive a written response from ConnDOT. On technical matters, the task of formulating a written response is delegated to the liaison engineer.

After the close of the comment period and certification of the public hearing transcript the liaison engineer prepares a post-hearing analysis. This is a letter-form report from the Commissioner of Transportation to the chief local elected official. The analysis contains the following information:

1. The alternatives considered.
2. Attendance at the hearing.
3. A summary of the issues raised by the public.
4. The responses of ConnDOT to all questions and comments.
5. ConnDOT's intended action.

The public hearing transcript is then distributed.

#### SECURING FEDERAL AID

Connecticut, like most other states, vigorously pursues federal aid for highway construction. On federally-aided projects, FHWA funds 80 percent of all eligible costs. The financial program established by the General Assembly was predicated on projected levels of federal participation. Exceeding projections will offset cost overruns, decrease the time required for program implementation or reduce the

State's share of the cost. The reverse would be true if projections are not realized.

During my assignment as a liaison engineer, ConnDOT never delayed advertising or awarding construction contracts because of funding constraints, nor did they delay advertising until federal funds became available. However, when unobligated federal monies became available, projects were repackaged to qualify for that aid. The primary source from which federal funds were obtained was the Highway Bridge Replacement and Rehabilitation (HBRR) Program.

To be eligible for HBRR funds the existing structure must appear on the FHWA's National Bridge Inventory and meet the following criteria:

1. Sufficiency rating of 80 or less to qualify for rehabilitation, or 50 or less to qualify for replacement.
2. Be structurally deficient or functionally obsolete.
3. Span a minimum of 20'.
4. Be accessible without payment of a toll.

The sufficiency rating is determined by the State-administered Structure Inventory and Appraisal (SI&A) process established by FHWA (23). The rating is a composite score of 23 parameters broadly categorized as follows:

- a. Structural adequacy.
- b. Serviceability and functional obsolescence.

c. Essentiality for public use.

d. Special reductions.

The structural adequacy is quantified with a composite score of the following items, where applicable: deck, superstructure, substructure, channel and channel protection, culvert and retaining walls, approach roadway alignment and inventory rating. The following guidelines have been established for condition ratings:

- 9 new condition
- 8 good condition, no repairs needed
- 7 generally good condition, potential exists for minor repair
- 6 fair condition, potential exists for major maintenance
- 5 generally fair condition, potential exists for minor rehabilitation
- 4 marginal condition, potential exists for major rehabilitation
- 3 poor condition, repair or rehabilitation required immediately
- 2 critical condition, the need for repair or rehabilitation is urgent; facility should be closed until the indicated repair is complete
- 1 critical condition, facility is closed; study should determine the feasibility for repair
- 0 critical condition, facility is closed and beyond repair

A bridge is structurally deficient if a condition rating is 4 or less for the deck, superstructure, substructure or culvert and retaining walls.

Bridge appraisals are used to evaluate a bridge in relation to the highway system and functional classification of which it is a part. Appraisal ratings are assigned to each of the following items: structural condition, deck geometry, underclearances (vertical and lateral), safe load capacity, waterway adequacy and approach roadway alignment. Bridges are functionally assessed using the following appraisal codes:

- 9 conditions superior to present desirable criteria
- 8 conditions equal to present desirable criteria
- 7 conditions better than present minimum criteria
- 6 condition equal to present minimum criteria
- 5 condition somewhat better than minimum adequacy to tolerate being left in place as is
- 4 condition meeting minimum tolerable limits to be left in place as is
- 3 basically intolerable condition requiring high priority of repair
- 2 basically intolerable condition requiring high priority of replacement
- 1 immediate repair necessary to put back in service
- 0 immediate replacement necessary to put back in service

A bridge is functionally obsolete if it has an appraisal rating of 3 or less for its deck geometry, underclearance, roadway approach alignment, structural condition, or waterway adequacy. A bridge is structurally deficient if it has an appraisal rating of 2 or less for its structural



condition or waterway adequacy.

Neither the CLE or the CEs prepared bridge ratings, they were provided by ConnDOT's Office of Bridge Safety and Inspection. However, the SI&A is a good source of data when considering rehabilitation and replacement alternatives. Also, whenever a project is identified for federal participation, the liaison engineer will use this information in the Request for Design Approval to FHWA.

Guidelines for federal-aid bridge replacements and rehabilitations specify that, unless excepted, all structural and functional deficiencies be corrected. The philosophy of the Emergency Bridge Program which was to halt deterioration or replace in part or in total bridges which are severely deteriorated. The potential for conflict through the pursuit of separate goals was identified early in the program.

Rather than process requests for exceptions on individual bridges, ConnDOT formulated design guidelines applicable to the Emergency Bridge Program only. The following were approved by the FHWA Division:

1. Full conformance with AASHTO bridge specifications unless otherwise excepted. All major exceptions will be documented and prepared for approval with justification. Design consultants are to certify the live load carrying capacity of the structure.

2. Bridge widths will not be altered for minor

rehabilitation projects. Those bridges that require deck replacements, superstructure replacements or complete replacements will be widened to the greater of the approach roadway or 28'.

3. Horizontal and vertical alignments will not be reviewed except in the case of bridge replacements. When it is determined that a bridge is to be replaced, the sight distances will be reviewed to determine if geometric improvements are required to attain the design speed.

4. HS-20 live load capacity will be provided unless exempted.

5. Parapets shall conform to AASHTO specifications including the provision for documentation of vehicle redirection by full-scale testing.

6. Approach railing shall meet AASHTO criteria.

7. All bridges shall be analyzed for fatigue using the AASHTO approach and repairs made as necessary.

8. Accident data should be evaluated at all structures to ensure that any high-accident locations and safety problems are identified. Structures with a higher than normal accident history should be considered for replacement rather than rehabilitation to correct the geometric as well as structural deficiencies.

When federal funding of a project is anticipated the liaison engineer and bridge review engineer monitor the consultant's submissions for conformance to these

guidelines. At the time preliminary design of a project is complete, Design Approval is requested. Design Approval is not an obligation of federal funding, it is a statement that the project development is consistent with FHWA guidelines.

On the Emergency Bridge Program, the logistics of pursuing Design Approval were as follows. ConnDOT's Transportation Chief Engineer, in a memo drafted by the liaison engineer, submits the formal request to the FHWA Division Administrator. The memorandum includes a concise description of the project, and addresses the status of project-related approvals such as environmental permits, railroad agreements, historical resource requirements and the disposition of salvage.

Subsequently, the FHWA Division Structural Engineer meets with the CLE at which time the liaison engineer will make a brief presentation of the project. Based primarily on the recommendation of the Division Structural Engineer, the Division Administrator will issue or deny Design Approval.

#### PROCESSING CONSTRUCTION CONTRACTS

Construction contracts are comprised of one or more state projects, a single state project consists of one or more bridges. On the Emergency Bridge Program, Greiner construction contracts included up to eight bridges. All construction contracts receive a treatment known as

"processing" immediately before distribution to bidders. Processing includes assembling the contract documents; preparation of contract award and construction schedules, project cost estimates, computer data files and the design report; distribution of advance copies of contract documents and preparation of ConnDOT and FHWA transmittal memoranda.

At the time of processing, design issues have been addressed through several reviews and should cause no concern. However, the general provisions are prepared at this point by the liaison engineer and provide for contract time, liquidated damages and other contractor-limiting stipulations. These provisions receive no review before distribution to bidders.

The contract should be developed in an orderly and clear manner. The parties involved in the design process become familiar with a project over a period of months or years. Bidders are usually allowed four weeks in which to prepare a binding price proposal which may exceed \$10 million. Courts resolve ambiguities in contracts against the preparer.

The cost estimate is an important feature of contract development. This estimate is prepared by the liaison engineer; no pre-bid distribution is allowed. A copy of the estimate is placed in a an envelope, sealed and turned over to ConnDOT's Engineer of Contracts who in turn places

it in a safe. On the letting date, all bids are publicly opened and read aloud; then the engineer's estimate is opened and read.

If the low bid is between 85 and 110 percent of the engineer's estimate, no further action is required of the liaison engineer. If the low bid is outside that range, the liaison engineer must prepare an analysis of the bids addressing the disparity and recommending rejection of all bids or award to the low bidder. Consequently, it is imperative that the liaison engineer be attuned to current construction cost trends.

## CHAPTER VII

### REPRESENTATIVE BRIDGE PROJECTS

Various settings and project scopes entail different liaison activities and even fast-track projects do not progress from inception through completion in one year. Therefore, I have chosen four projects to discuss which I believe cumulatively characterize my experience on the Emergency Bridge Program. Each of the projects discussed is intended to provide insight to a phase of CLE involvement and the technical and administrative responsibilities of the liaison engineer.

My experience on Bridge No. 01594, Kent addresses environmental planning and preliminary design up to the point of selecting an alternative for final, detailed design. The development of final design for two bridges are included in this chapter; Bridge No. 00111, Bridgeport is a rehabilitation and Bridge No. 00618, Colebrook is a replacement. Finally construction phase activities are discussed as they relate to Bridge No. 00761, Milford.

#### BRIDGE NO. 01594, KENT

My involvement with this project can be described as environmental planning and preliminary design. The environmental planning consisted of assisting in the preparation of the draft and final Environmental Assessment/Section 4(f) Findings Evaluation. For that

phase of the project I was in a support role to ConnDOT's Office of Environmental Planning, the unit directly responsible for preparation of the documents. Preliminary design may be described as the process by which a single option is selected from a group of feasible alternatives. The CLE is the unit primarily responsible for that function.

Determining how to best provide safe vehicular and pedestrian traffic without significantly impacting historical, recreational or environmental resources was a complicated process.

The bridge site is located in the town of Kent (Figure 2), a rural community with a population of 2,640. A short distance east of the bridge is the intersection of Route 341 with U.S. 7 which forms Kent's main street.

Immediately west of the bridge is the campus of the Kent School, a private institution. There are residences along the north and south sides of Route 341 east of the bridge. The bridge is located on a tangent section within a broken-back horizontal curve.

The existing Route 341 bridge was constructed in 1923 and is a riveted steel Parker through truss with a single span of 216' supported on full-height concrete abutments. All truss members consist of paired angles or paired channels connected with riveted lacing, except for the top and bottom chords and inclined end posts, which are box sections. The bridge floor is a concrete slab with a

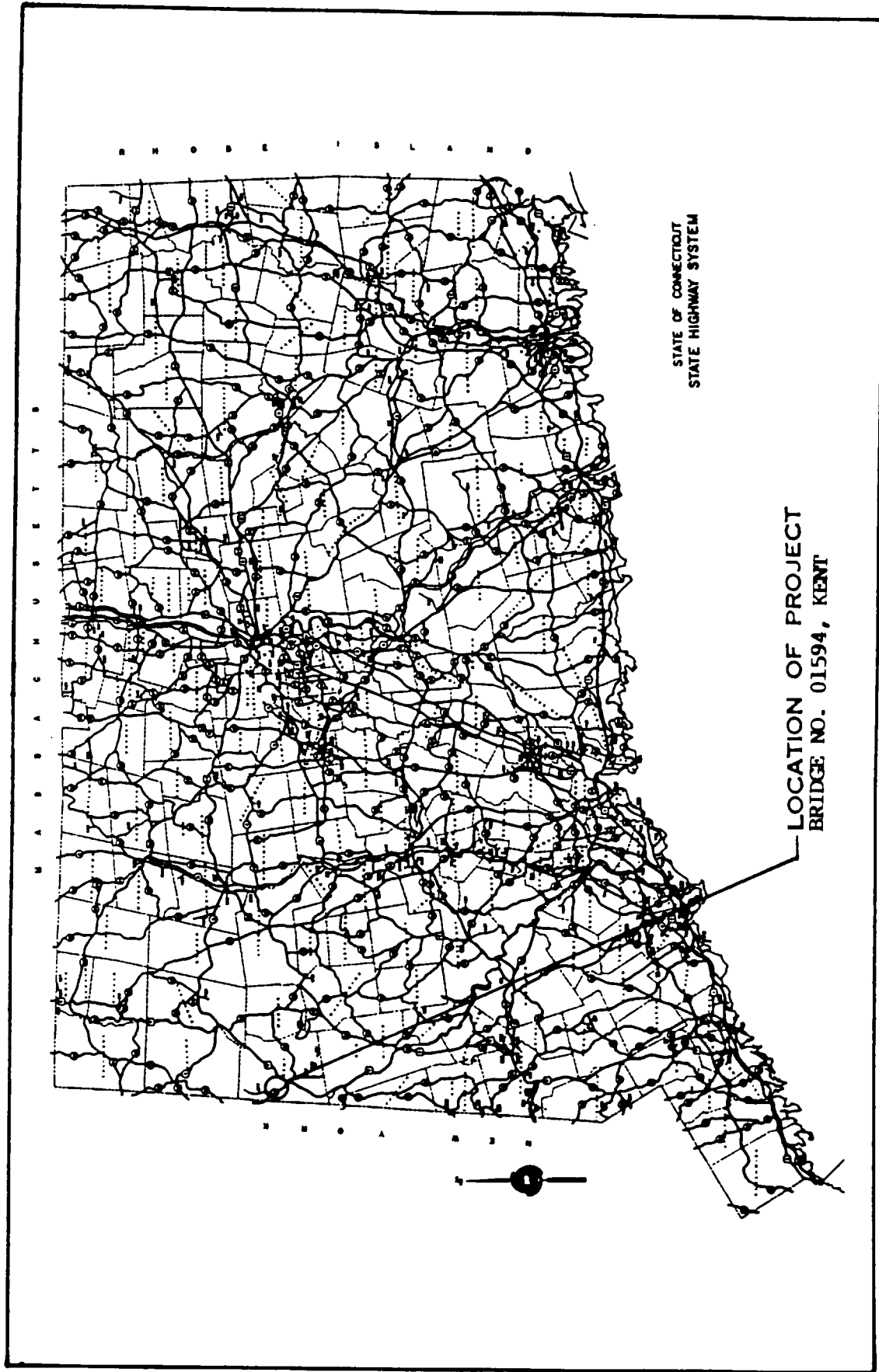

FIG. 2.-Location Map, Bridge No. 01594, Kent



bituminous wearing surface supported on stringers and floor beams.

Clear roadway width is 23' between the faces of beam-type guiderails which extend the full length of the bridge and approaches. Current design standards would dictate a 28' minimum roadway and shoulder width.

In 1967 the bridge was modified to add a 5' wide pedestrian walkway. This walkway is located on the south side of the structure, supported by cantilevers attached at the lower chords.

The existing structure is listed in the State of Connecticut's Historic American Engineering Record and the State Historic Preservation Officer determined that the structure meets the criteria necessary for listing in the National Register of Historic Places. As a result of the bridge's historic value and the proposed project, the U.S. Department of Transportation requirements for Section 4(f) processing were applicable.

The Evaluation Report (24) prepared for this structure indicates that the structural steel above the driving surface is in fair to good condition. The condition of the deck is poor along the entire length of the bridge. Visual inspection from below revealed a dense pattern of map and longitudinal cracking. Numerous concrete spalls exposed highly corroded reinforcing steel.

Field sampling and testing of the concrete deck were

also included in the Evaluation Report phase. Two samples were taken at each of eight locations. One sample was taken approximately 2" below the surface of the concrete deck and the second approximately 4" below the surface. Each of these samples was tested to determine the concentration of chloride ions. Of the 16 samples taken, 13 were found to have ion content greater than 2.0 lbs/c.y., the level at which deck removal is warranted.

Steel below the deck has undergone medium to severe deterioration. Section loss of some members due to corrosion and delamination was as high as 75 percent.

In response to the poor condition of the structure, the following five alternatives were considered:

Alternative A - do nothing

Alternative B - rehabilitate existing structure

Alternative C - replacement on existing alignment

Alternative D - replacement on new alignment and  
elimination of existing structure

Alternative E - constructing a new structure with  
retention of existing structure

Each alternative will be discussed.

#### Alternative A

This alternative involves no remedial structural activities, leaving the bridge open to traffic in its present condition. Due to progressive deterioration, eventually a critical element of the structure would degrade to a point requiring vehicle weight restrictions or

complete closure to traffic.

Alternative A was not considered acceptable.

#### Alternative B

This alternative involves structural repairs to the existing structure to provide for HS-20 live load capacity. It was determined (24) that the following items would be the minimum required:

1. remove existing concrete deck,
2. remove and replace floor system including stringers, floor beams and lateral bracing,
3. blast clean and repair or replace deteriorated truss members,
4. remove and replace bearings,
5. replace deck,
6. clean and paint steel,
7. repair concrete abutment cracks.

Because the structure was constructed in 1923 when the automobile was in its infancy, live load designs for that era did not consider the loading capacity for present day vehicles. According to the consultant engineer, if the structure were in perfect condition, the live load rating would not exceed H-10 using the working stress method. Although this opinion was not shared by the CLE or ConnDOT it was agreed that in-kind replacement would not ensure design capacity.

Depending on the actual level of deterioration

encountered, extensive in-kind replacements and supplemental strengthening necessary to attain the HS-20 rating would likely jeopardize the structure's historic integrity, thereby defeating the principal reason for considering rehabilitation. This option would also perpetuate the substandard lane widths.

The nearest alternative crossing involves a detour of 15 to 20 miles, an unacceptable encroachment on convenience and the responsiveness of emergency services. Therefore, Alternative B would require a temporary bridge while the existing bridge was being rehabilitated.

The estimated cost of this alternative including the detour bridge was \$1.3 million.

Based on the structural, safety and financial considerations discussed, it was concluded that rehabilitation of the existing structure was not reasonable.

Alternative C

This alternative involves the demolition of the existing bridge and construction of a replacement structure on the same alignment as the existing bridge. A temporary bridge on a separate alignment would be required. This alternative would involve minimum permanent right of way acquisition and long term impacts on adjacent properties. However, construction impacts on land and the river would be considerable.

The temporary bridge would be in place for nearly two

years, upsetting current land use at the Kent School and residences on the east approach. This alternative requires the construction of two (permanent replacement and temporary) bridges and removal of two (existing and temporary) bridges; in-river construction activities would be extensive.

Additionally, this alternative would remove the historic resource and perpetuate an undesirable horizontal alignment. The estimated cost of Alternative C is approximately \$2.1 million.

Due to the high cost and adverse impacts described above, this alternative was not recommended.

#### Alternative D

Under this alternative, a new structure would be constructed to the north and immediately adjacent to the existing bridge; a curved horizontal alignment would eliminate the broken-back curve.

Staged construction techniques would be used. The first stage of construction involves building a portion of the new structure just north of the existing bridge. During this time, vehicles and pedestrians will continue to use the existing bridge. After the first construction stage is complete, traffic would be shifted onto it and the old (existing) structure demolished. Construction of the remainder of the new structure would follow.

Under this plan (Figure 3), no temporary bridge is

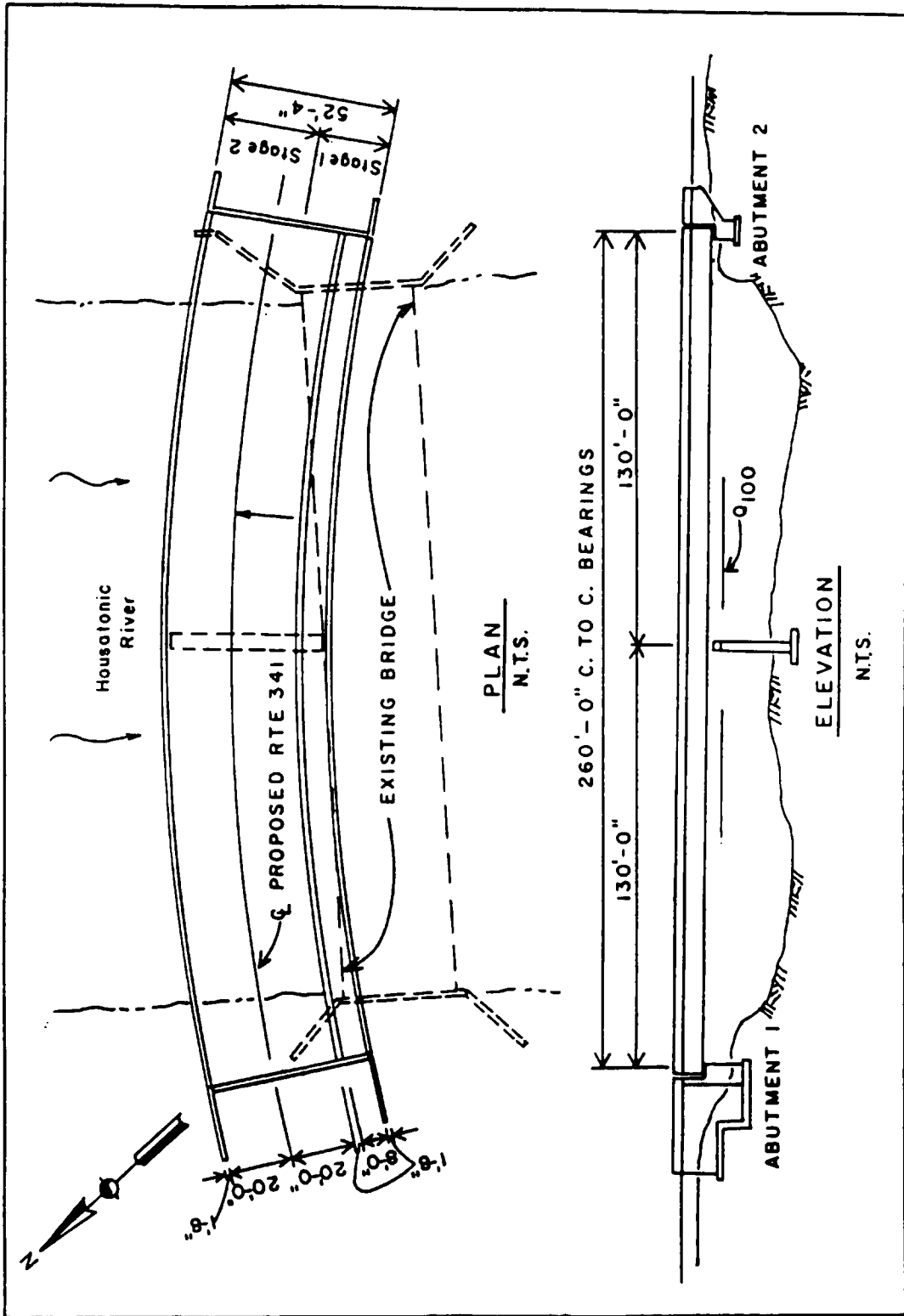

FIG. 3.-Plan and Elevation, Bridge No. 01594, Kent

required. At the abutments and approaches the new construction will be in approximately the same location as the existing. Impacts to adjacent properties would be comparatively small. The existing bridge would be demolished, thereby eliminating a historical resource. The estimated cost of this alternative is \$1.9 million.

Alternative D was recommended.

#### Alternative E

This option involves construction of a new bridge on a new alignment with retention of the existing structure to serve as a pedestrian walkway. The new structure would be on a curved horizontal alignment upstream of the existing bridge, similar to Alternative D but farther upstream.

Under this alternative, the existing structure would not be required to carry vehicular traffic. Nonetheless, certain rehabilitation would be necessary to ensure public safety.

Once the new structure is opened to vehicular traffic, the old bridge would cease to be a part of the State highway system. Consequently, future maintenance costs would not be borne by the State. During coordination with the Town of Kent it was made clear by the First Selectman that they have no interest in preserving the existing structure. The Town's unwillingness to accept the bridge eliminated this alternative from further consideration.

After the draft Environmental Assessment was

distributed a meeting was held with the First Selectman to arrange for a public hearing as described in Chapter VI. The public hearing was conducted on November 19, 1986. During the comment period of the hearing, three persons spoke for the record, the First Selectman and two representatives of the Kent School. All three supported the recommended plan (Alternative D) and requested specific considerations. Most important of these was a request by the school's athletic director that the new bridge have no more than two spans. Two or more river piers would cause unacceptable interference to the competitive rowing activities sponsored by the school. The Manager of Bridge Design granted the request despite the potential economy of a three-span structure.

As a result of the positive response at the hearing, Alternative D was adopted and the design consultant immediately directed to prepare a structure type study for feasible one- and two-span structures. The structure types and their estimated costs are shown in Table 2.

Table 2. Feasible Structure Types and Estimated Costs for Replacement of Bridge No. 01594, Kent

Structure Type	Estimated Cost (\$ million)
one-span, steel plate girders	1.95
one-span, steel box girders	2.10
two-span, steel plate girders	1.52
two-span, steel box girders	1.79
two-span, concrete box girders	1.84



The decision process began with span arrangement and progressed to girder type. The principal considerations were geometrics, river and land impacts, cost and aesthetics.

Both single span designs required deep, constant-depth girders to control live load deflections on a simple span. To maintain the required waterway opening and hydraulic underclearance, the vertical alignment for a one-span bridge would have to be nearly 7' higher than the existing grade line. This would result in severe impacts on adjacent property and intersecting roadways. Sight distance requirements could not be achieved within reasonable construction limits.

For single-span structures, the potential uplift on the inside of the curve would have to be addressed. Depending on the radius of the curvature selected for design, a special abutment would be needed. The consultant recommended the use of "outriggers", radial extensions of the abutment stems toward the outside of the curve, be used. A stability beam transmitting superstructure loads would bear on the extension. Mitigating factors of the single span arrangement were reduced levels of disturbance on recreation and favorable hydraulics.

Due to the cost and land impacts, there was a consensus by the CE, CLE and ConnDOT that a one-span structure should not be provided.

Figure 4 shows the three two-span alternatives studied. The consultant recommended the two-span, precast, post-tensioned, segmental concrete box girder design. This option required an elaborate construction operation to cast, erect and tension the segments. A gantry supported by the partially constructed substructure and temporary supports was included in the plan.

This type of construction has proven itself economically competitive at numerous locations. However, it was the shared opinion of the CLE and ConnDOT that the limited size of the bridge, the remote location, unwieldy alignment and stage construction precluded economy at this site. The consultant's estimated unit costs were suspect.

There was agreement between the CLE and ConnDOT that steel plate girders would yield the most economical structure for a two-span bridge. However, based on aesthetic considerations the Manager of Bridge Design opted for steel box girders. Accordingly, the consultant was advised of the type selection and directed to begin design.

When I contacted FHWA and attempted to obtain their concurrence for the type selection the issue of economy was raised and concurrence withheld. At a subsequent meeting attended by the Manager of Bridge Design, Supervisor of Bridges and Structures, FHWA Division Structural Engineer and myself, the type selection was revised to steel plate girders.

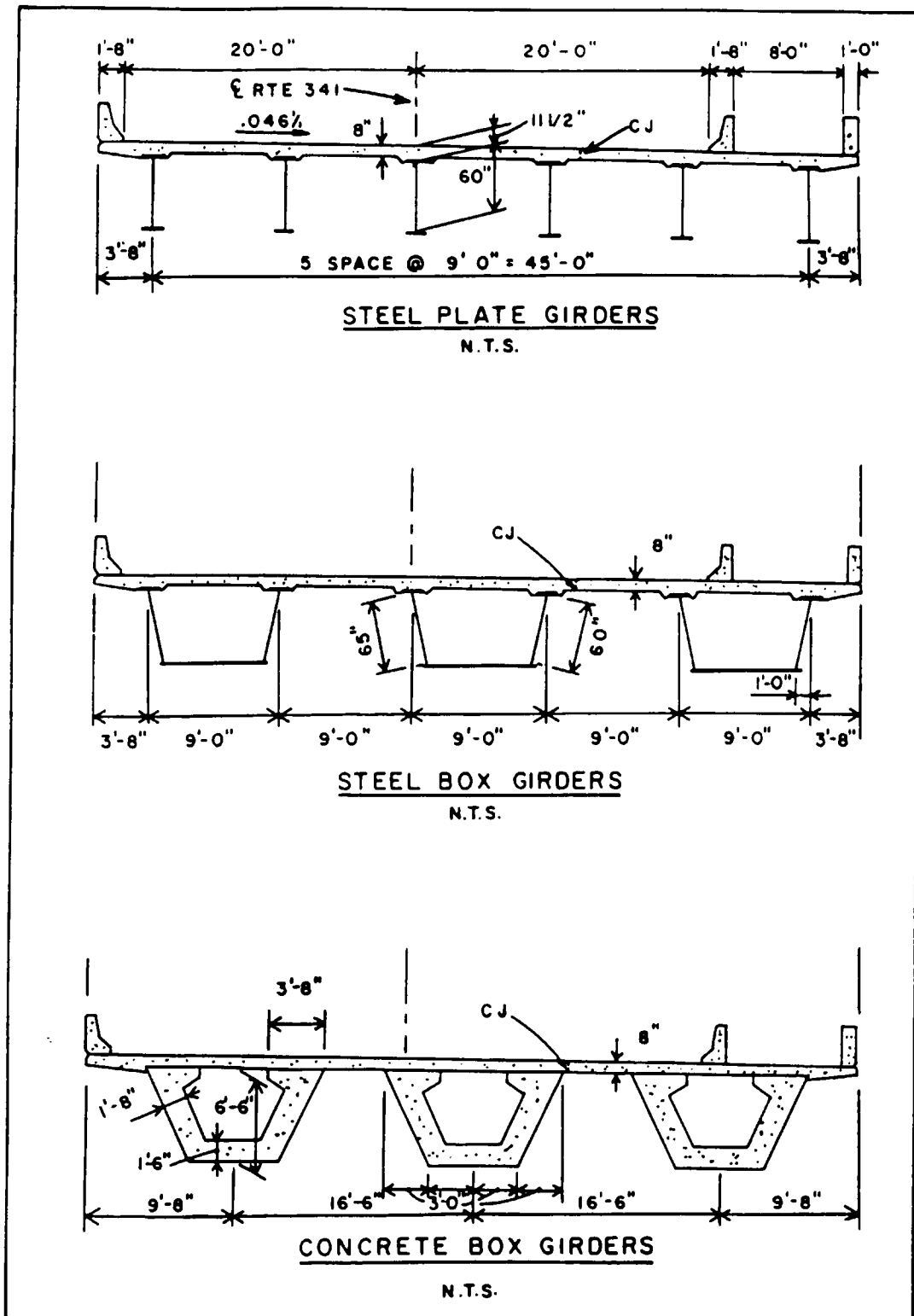

FIG. 4.-Alternative Superstructures for Bridge No. 01594, Kent

At this writing a Structure Layout for Design is being prepared, bids are being solicited from boring contractors, and the Final Hydraulic Report is being reviewed.

#### BRIDGE NO. 00111, BRIDGEPORT

Bridge No. 00111 carries a major expressway (Connecticut Turnpike) over local roads, three sets of Metro-North Commuter Railroad tracks and Bridgeport Harbor. The Connecticut Turnpike is a segment of Interstate Highway 95 (I-95), the latter being the principal commercial transportation corridor along the east coast of the United States. Bridgeport (Figure 5) is the State's most populous community; I-95 provides continuity for commuters along the densely populated shoreline of southwestern Connecticut. Because of high volumes and closely-spaced entrance and exit ramps, the volume of traffic crossing the bridge has not been determined by count. However, it is known that the two-way ADT exceeds 140,000 making this structure the most highly-trafficed of any on the Emergency Bridge Program.

The bridge type is steel plate girders composite with a concrete deck. The 23 spans (Figure 6) provide a total length of approximately 2500' along the mainline; three ramps are also supported.

The rehabilitation of Bridge No. 00111 includes structural steel repairs, patching concrete piers, replacing pin and hanger assemblies and repairing and

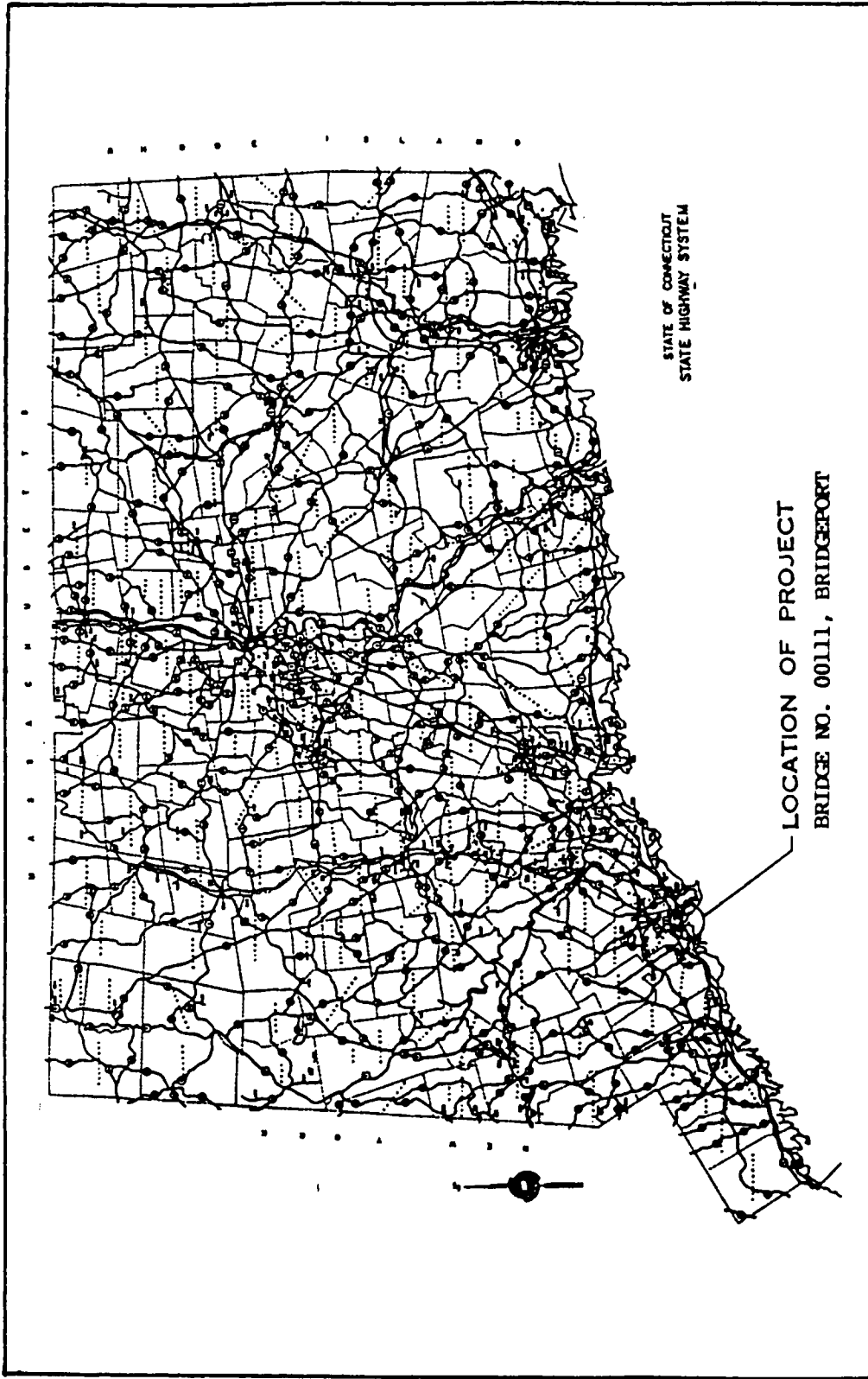

FIG. 5.-Location Map, Bridge No. 00111, Bridgeport

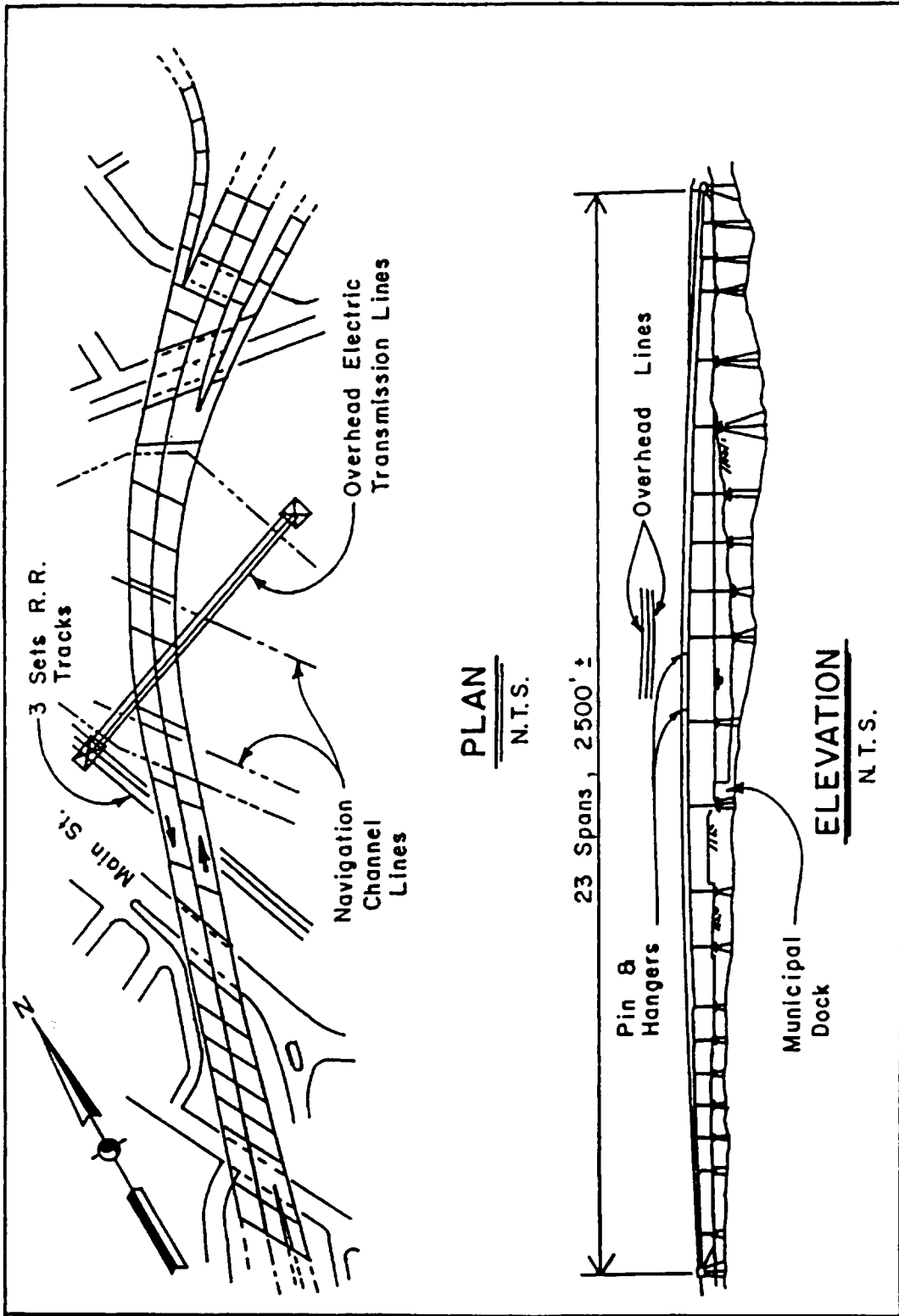

FIG. 6.-Plan and Elevation, Bridge No. 00111, Bridgeport

replacing bearings. The estimated cost of the project is approximately \$2.5 million.

Replacement of the 32 pin and hanger assemblies presented unique problems at this location. In general, pin and hangers came under close scrutiny following the collapse of the Mianus River Bridge. Pin and hangers are obsolete, having been outmoded by advances in the design and construction of continuous steel structures. Connecticut has 78 bridges (25) in service that were originally constructed using the pin and hanger mechanism. Each of these structures has been addressed or will be addressed to ensure its integrity.

All non-redundant devices are being eliminated or retrofitted with a backup support system. The most common backup system is a bracket or "catcher's mitt" attached to the lower flange of the cantilevered girder and extending horizontally beneath the suspended girder. In the event of failure by the primary connection, the suspended span will be "caught" by the backup system.

Redundant installations are pin and hanger devices where, in the event of failure, the loads of individual girders can be transmitted to an adjacent girder via the deck and cross frames without catastrophic failure. The pin and hangers on Bridge No. 00111 are redundant and being replaced in kind.

Minimizing traffic disruption while replacing the pin

and hangers was a principal design control at this location. An analysis of temporal-volume data indicated that lane closures could be tolerated from the hours 9:00 P.M. to 5:00 A.M. only.

Originally, the consultant had proposed a plan in which the jacking apparatus was located on the bridge's top side. A strong-back was to be cantilevered across the expansion joint to support the girder rigging and serve as a jacking base (Figures 7,8). Once the suspended girder is unweighed and a single pin removed, the operation cannot be suspended or terminated; the work must continue through completion.

The complete procedure includes: removal of the hanger plates and pins, sand blasting the girder webs to near white, applying vinyl wash and paint primer, installing replacement hanger plates and pins, releasing the jack and removing the apparatus. After consulting with specialty contractors and ConnDOT construction personnel, it was concluded that all of the above could not be accomplished in an eight-hour period.

At the direction of the Manager of Bridge Design, the CLE and CE evaluated alternative techniques requiring shorter duration lane closures. Three alternative methods were considered feasible. All but one method would result in a permanent reduction of the navigation clearance.

Permission had already been obtained from the Coast



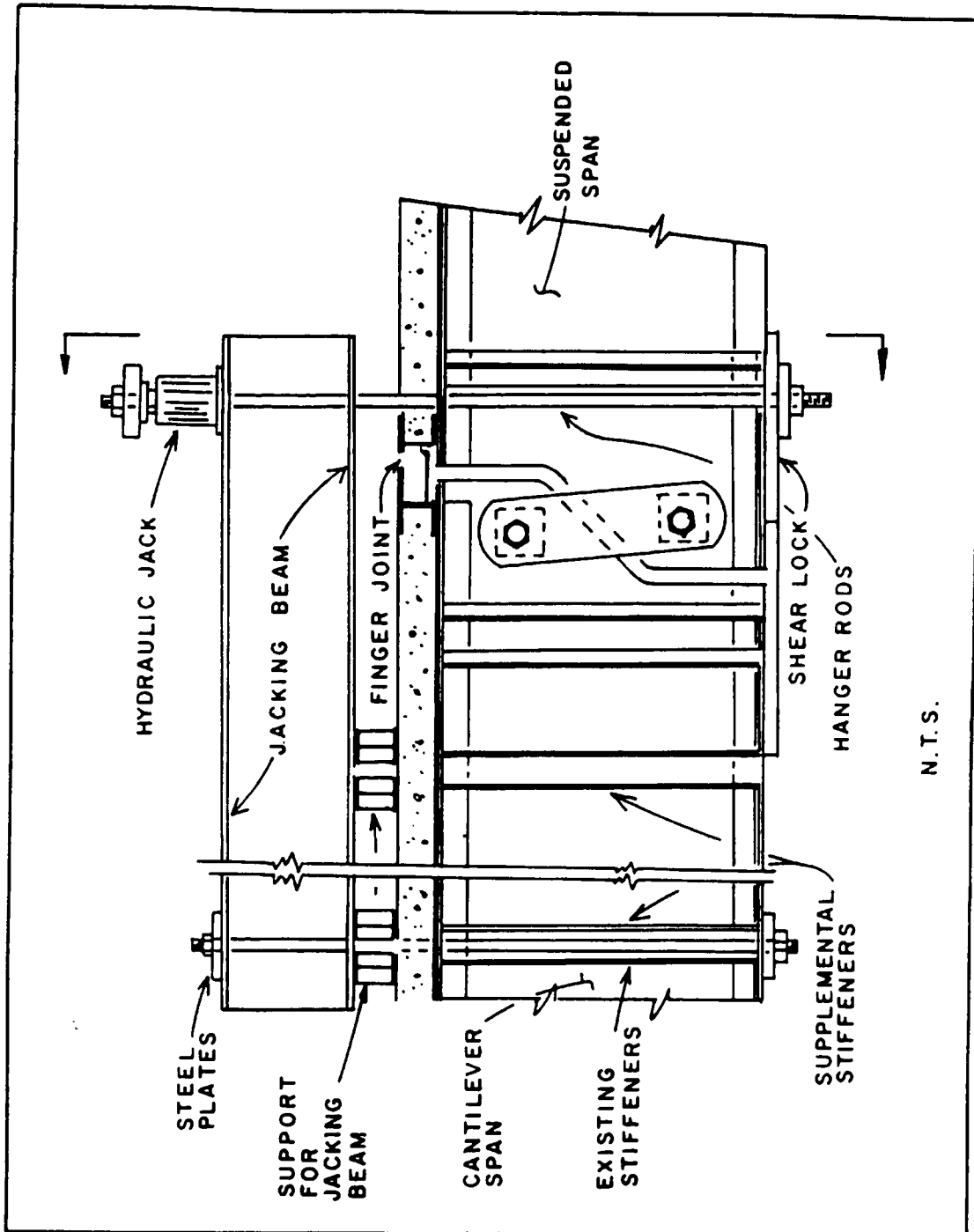

FIG. 7.-Elevation of Above-deck Jacking, Bridge No. 00111, Bridgeport

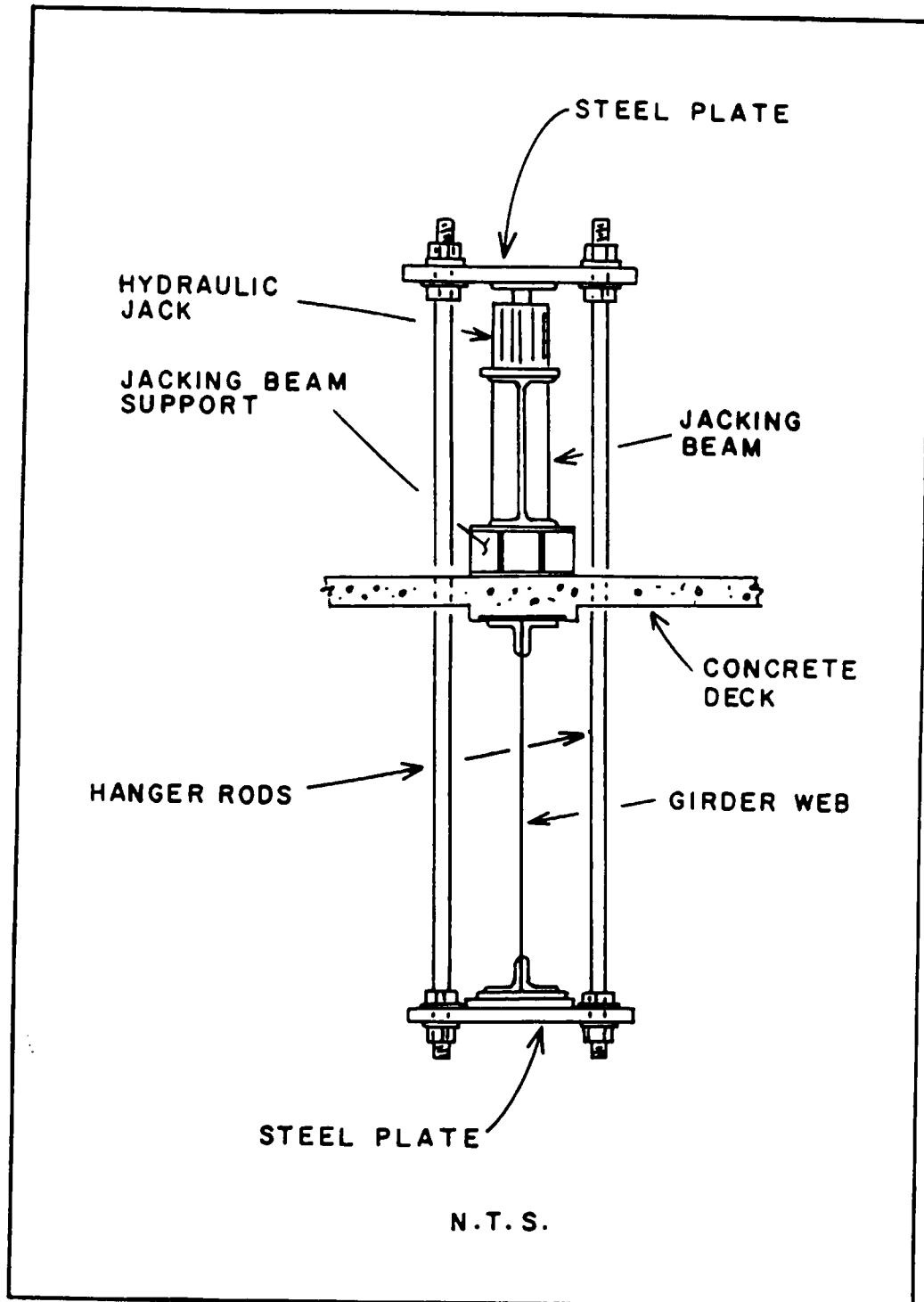

FIG. 8.-Section of Above-deck Jacking, Bridge No. 00111, Bridgeport

Guard to temporarily encroach on the clearance envelope; this was necessary for scaffolding and falsework. The coordination and/or permit process necessary to implement a permanent reduction would, at best, delay advertising. It was decided to jack from below as shown in Figures 9 and 10. During non-work hours, the opening in the deck would be covered by a steel plate designed to accommodate HS-20 live loads. This plan will allow the contractor one or two nights to remove the deck and install the rigging. The girder jacking and assembly replacement must then be completed in a single night.

This project also included an interesting administrative development. In early 1984 the Phase I inspection was conducted. The Evaluation Report indicated that deck repairs, rail retrofitting, median barrier construction and painting were necessary. In November 1984 a construction contract, providing for that work was awarded utilizing federal I-4R funds. As a condition of Design Approval, FHWA requires that a professional engineer certify a 20 year useful life for the rehabilitated structure; such a certificate was provided by the consultant.

As construction activities progressed, considerable deterioration of structural steel, not previously identified, was discovered. Consideration was given to ordering the work as part of the ongoing project. There

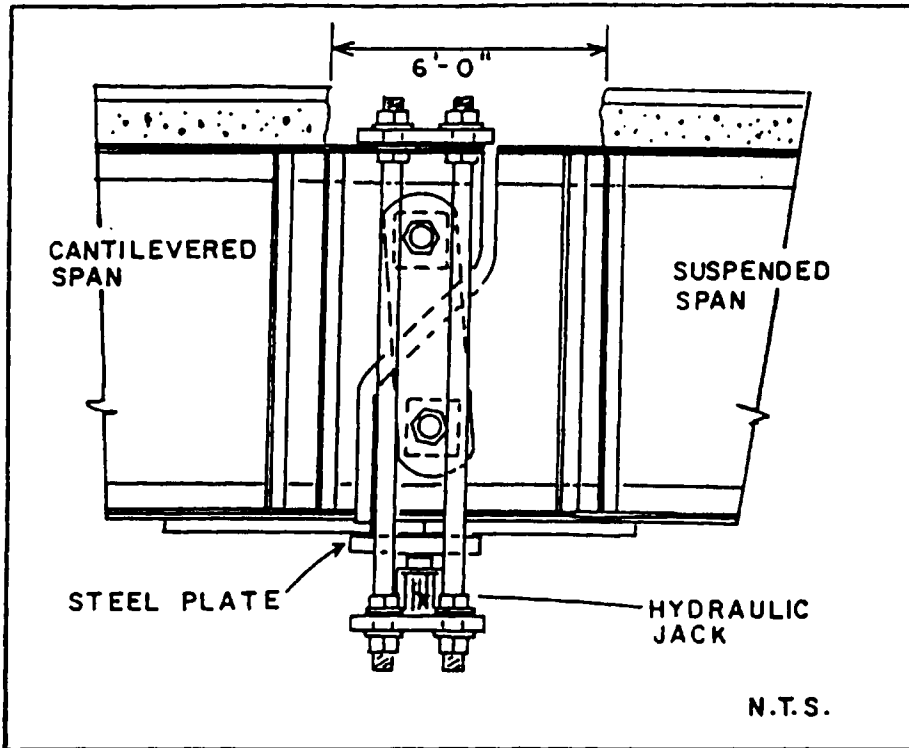

FIG. 9.-Elevation of Below-deck Jacking, Bridge No. 00111, Bridgeport

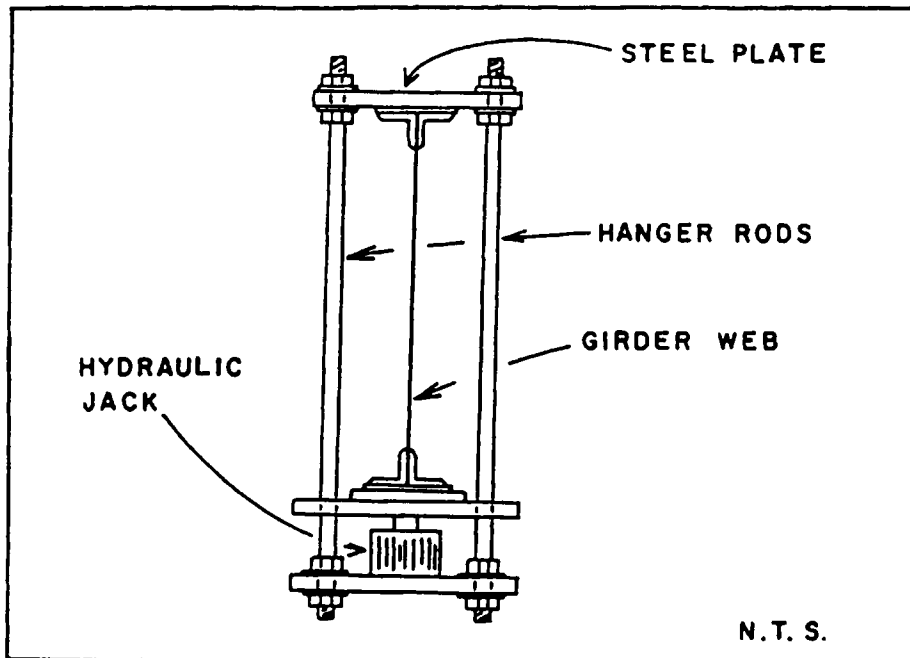

FIG. 10.-Section of Below-deck Jacking, Bridge No. 00111, Bridgeport

was a consensus by design personnel that the additional work was extensive and a competitive price could not be negotiated with the contractor. Therefore, in June 1986 it was decided to develop a separate construction contract for subsequent bidding. This second contract is the one with which I was involved.

When a federal transportation bill was made law in May 1987, ConnDOT designated this project as one for which federal funds would be pursued. I prepared the Request for Design Approval and Request for Funding Obligation. During FHWA's review it was learned that the bridge was ineligible for HBRR funds since federally-assisted rehabilitation had been undertaken within the past 10 years.

ConnDOT appealed this declaration of ineligibility on the grounds that both projects were necessary to bring the structure's sufficiency rating above 80 and that the second project was an integral part of a rehabilitation program. FHWA issued a waiver and funded the project.

My involvement on this project was extensive and included civil reviews, coordination with the Coast Guard, traffic/pin-and-hanger replacement study, presentation to FHWA, preparation of engineer's estimate and processing.

At this writing the project is being advertised for bids.

BRIDGE NO. 00618, COLEBROOK

The subject bridge carries a two-lane highway (Route 8)

over Sandy Brook in rural northern Connecticut (Figure 11). The preliminary and final design of Bridge No. 00618 was the most multi-faceted Emergency Bridge Program activity with which I was involved. The determinations of alignment, cross section, superstructure type and length were made in consideration of the relationships between stopping sight distance, intersection sight distance, hydraulics, fish and wildlife preservation, right of way, safety, structural and geotechnical factors.

The existing bridge, constructed in 1913, is on a short section of tangent alignment between reverse curves with approximate radii of 600' and 480'. Riverton Road, a local highway, intersects Route 8 with a skew of 65° approximately 220' north of the existing bridge (Figure 12). These radii and intersection skew are nonconforming to the point of constituting a hazard.

Sandy Brook is an environmentally sensitive watercourse. In 1986 the brook was stocked with approximately 6000 trout and 80,000 Atlantic Salmon fry. The salmon release was part of a program by cooperating federal and State agencies to reintroduce this native species to rivers and streams from which they have been absent for 10 to 20 years. Additionally, the brook and its banks are the habitat of numerous fauna.

Hydraulically, Sandy Brook is quite complex. The drainage area at the site is approximately 35 square miles;

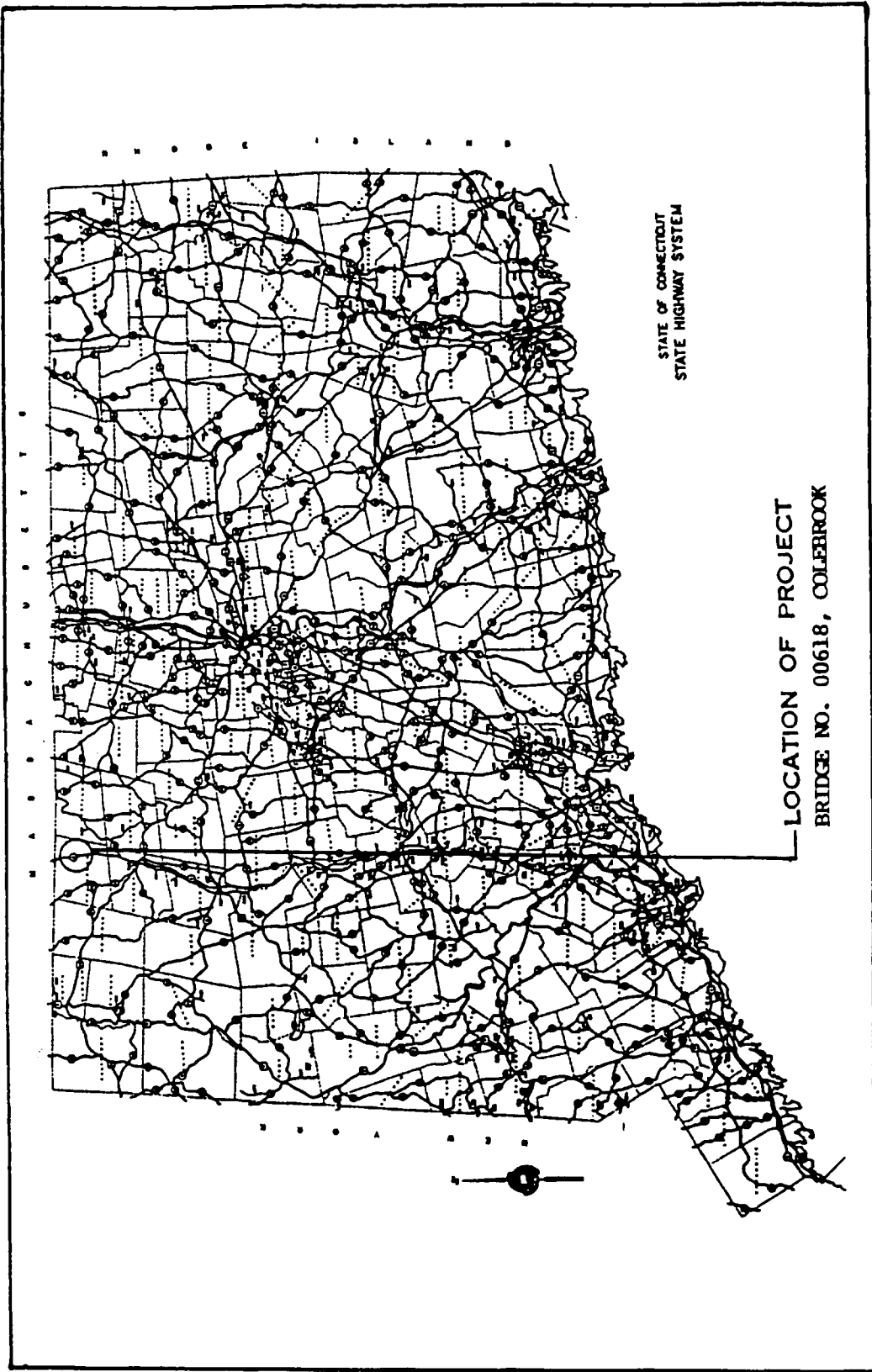
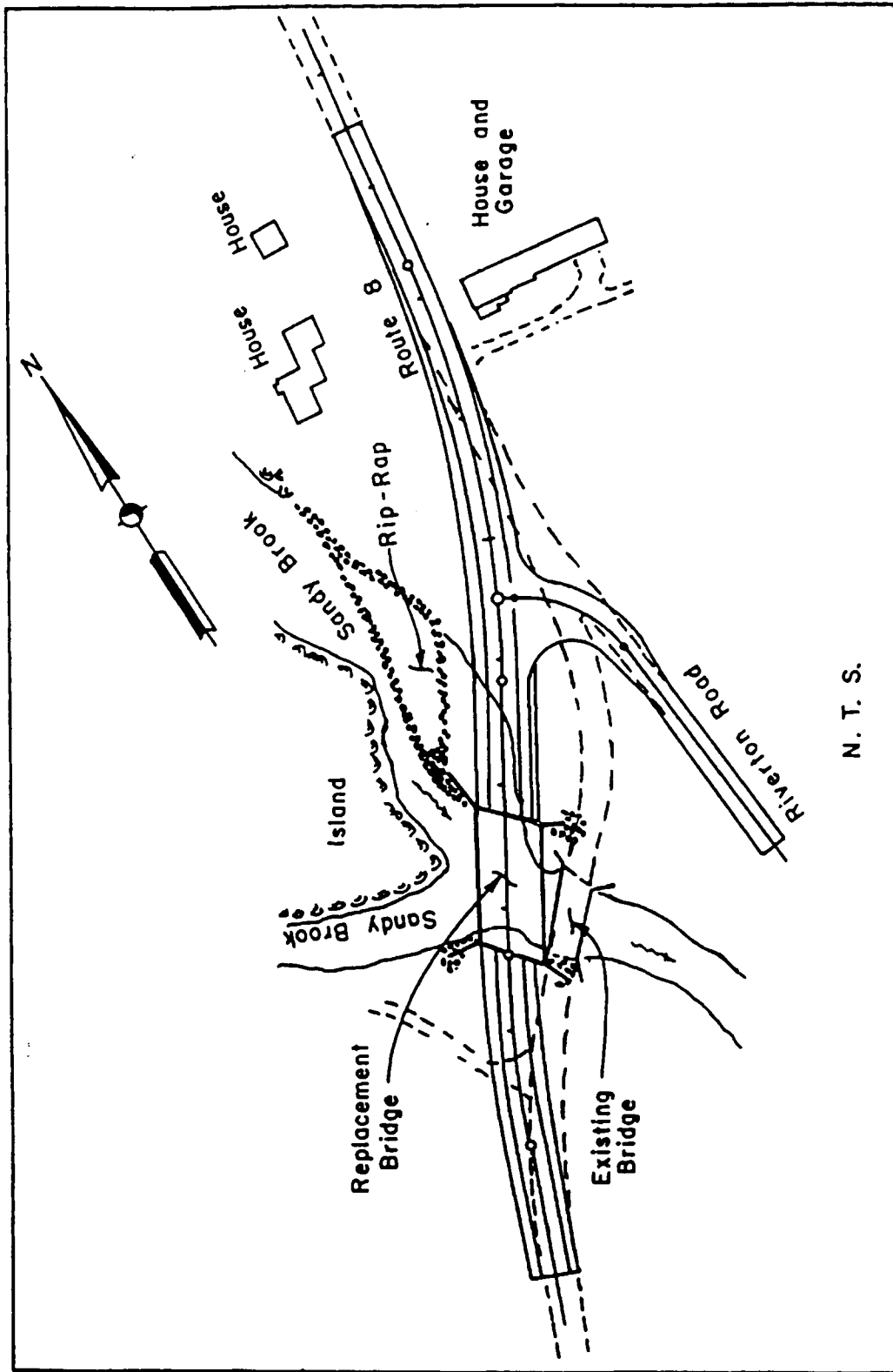

FIG. 11.- Location Map, Bridge No. 00618, Colebrook



N. T. S.

FIG. 12-Plan, Bridge No. 00618, Colebrook



channel encroachment lines have not been established. The CE averaged the FHWA and USGS methods to develop 50- and 100-year design discharges of 5750 cfs and 7500 cfs respectively. For those discharges the flow regime fluctuates within the project area. Subcritical flow prevails in the reach containing the bridge, the reaches immediately upstream and downstream of the bridge are supercritical for discharge rates of interest.

An extreme event in 1955 resulted in the development of stream braiding upstream of the bridge. Two primary stems, carrying nearly equal flows, form a confluence immediately above the existing bridge. The island formed by the stems is being visibly eroded, particularly at the upstream end.

As previously stated, the general philosophy of the Emergency Bridge Program was to maintain existing alignments. In this case, the combination of structural deterioration and accident history were compelling enough to warrant structure replacement and realignment.

The most desirable highway alignment would eliminate the reverse curve by projecting the primary tangents to an intersection and providing a single, flat curve. The impact of such an alignment on the stream environment and private property were unacceptable. A reverse curve could not be avoided. Three plans were studied, each crossing Sandy Brook with a different orientation and location. The alignment in Figure 12 was selected as the best balance

between highway safety, right of way, economic and environmental considerations.

To avoid delays and revisions at advanced stages of design, the DEP was involved during preliminary design. After review of the project, including the alternative alignments, DEP concurred with the conceptual design. Because of the wetlands and wildlife resources, DEP advised that final approval would be contingent on the following:

1. After completion of the new bridge, existing abutments and approach fills be removed and areas regraded.
2. Recreating wetland areas where feasible to replace those lost by channel relocation.
3. Providing a dry passage near the abutment face for animals.
4. The relocated channel gradient be as close to that of the existing channel as possible.
5. Riprap be placed only in areas necessary to protect the new bridge.

Following submission of preliminary plans it was discovered that the geometry did not provide intersection sight distance compliant with ConnDOT's design standards. Because DEP's concurrence had already been obtained, the horizontal alignment of Route 8 was considered fixed. The unrestrained design parameters were cross section elements and dimensions, Riverton Road geometry and Route 8 vertical geometry.

The designer's recommendation was to provide a 10' shoulder rather than the the typical 8' and accept the associated 385' of sight distance as a considerable improvement over the existing condition. The recommendation was not accepted and the consultant was directed to realign Riverton Road and provide a sidewalk on the downstream side of the bridge to achieve the desirable sight distance of 455'.

Based on hydraulic considerations, the minimum length of bridge was 116'. For this bridge length and height, one- and two-span structure types are economically competitive. Construction of an intermediate pier would require considerable in-stream disturbance for cofferdam construction, dewatering and concrete placement. For environmental reasons, two-span designs were not pursued at this location.

The Structure Type Study included a recommendation for adjacent prestressed concrete box beams. This was probably the most economical design but the span is slightly greater than the maximum ConnDOT uses for that type of construction. Experience has shown that manufacturing tolerances cannot be maintained for prestressed deck units exceeding 112'. A superstructure consisting of welded steel plate girders with a composite concrete deck was selected.

In the early stages of design development it was

proposed to maintain two-way traffic through the project area. Under Stage I, traffic would use the existing highway while the entire north abutment and most of the south abutment and deck were constructed. Traffic would then be shifted onto the newly-constructed partial deck and Stage II would include completing the south abutment and deck.

When the Structure Layout for Design (SL/D) was reviewed, the CLE bridge review engineer took exception to the placement of construction joints in the deck and abutment. A construction joint would detract from the slab's rigidity, possibly result in cracking of the bituminous overlay thereby allowing salt and moisture to penetrate the deck and abutment stem. To construct a substructure monolithically would require encroaching onto the existing Route 8. Based on the relatively low ADT of 2300, it was decided that the temporary inconvenience of alternating one-way traffic was preferable to the potential consequences of multiple concrete placements.

The consultant had recommended the use of full-height abutments on spread footings. The north abutment would be founded on rock at elevation 562.0. The recommendation was to found the south abutment on a seam of sand, gravel, cobbles and boulders at approximately elevation 557.0; at that location, rock is at elevation 553.0. This plan was presented in the Soil and Rock Report in June 1986 which

also indicated that up to 2" of settlement at the south abutment might occur. The report and the recommendations were approved by the CLE.

During the SL/D review there was concern about the integrity of the substructure. As this was being considered in April 1987, a bridge carrying the New York State Thruway over Schoharie Creek collapsed during an extreme event; early indications were that substructure scour was a principal cause of failure. The consultant was directed to redesign the substructure providing a pile foundation at the south abutment.

DEP's request for a creation of a "reclaimed wetland" to compensate for filling of a natural wetland presented an interesting legal question for ConnDOT. The Commissioner's authority to acquire right of way is limited to that necessary for highway and bridge construction. The reclaimed wetland was not necessary, per se, for highway construction; yet without providing the wetland, a permit would not be issued. Several meetings were held between the Office of Rights of Way, Attorney General's staff, Office of Bridge Design and CLE with no consensus as to the legality of the take. Finally, the CLE was directed to proceed with the acquisition as a normal highway take.

At this writing, the appraisal process is ongoing and final plans are being prepared for a December 1987 advertising date.

## BRIDGE NO. 00761, MILFORD

Bridge No. 00761 carries Route 15 over the Housatonic River in southwestern Connecticut (Figure 13). At this location, Route 15 is part of the parkway system and traffic is restricted to passenger vehicles and light trucks, no commercial vehicles are allowed. The bridge connects the Merritt Parkway with the Wilbur Cross Parkway. Construction of the bridge was completed in 1941. A toll plaza 400' east of the east abutment has been in continuous operation since 1941 and will be closed at the end of 1987.

Bridge No. 00761 crosses a tidal flat, the river and Metro-North Commuter Railroad tracks with 12 spans totalling 1824' (Figure 14). With the exception of concrete footings, the entire structure is steel. Three half-thru plate girders support transverse W33x141 floor beams. Originally, WF21x63 stringers were riveted to the top flange of the floor beams and an open steel grate welded to the stringers (Figure 15). Each thru girder has five pin and hanger assemblies. Up until this project, Bridge No. 00761 had received virtually no restoration.

The plans and specifications called for the following major items:

1. Installation of brackets at all pin and hangers.
2. Repair of certain floor beams.
3. Repair of certain stringers.

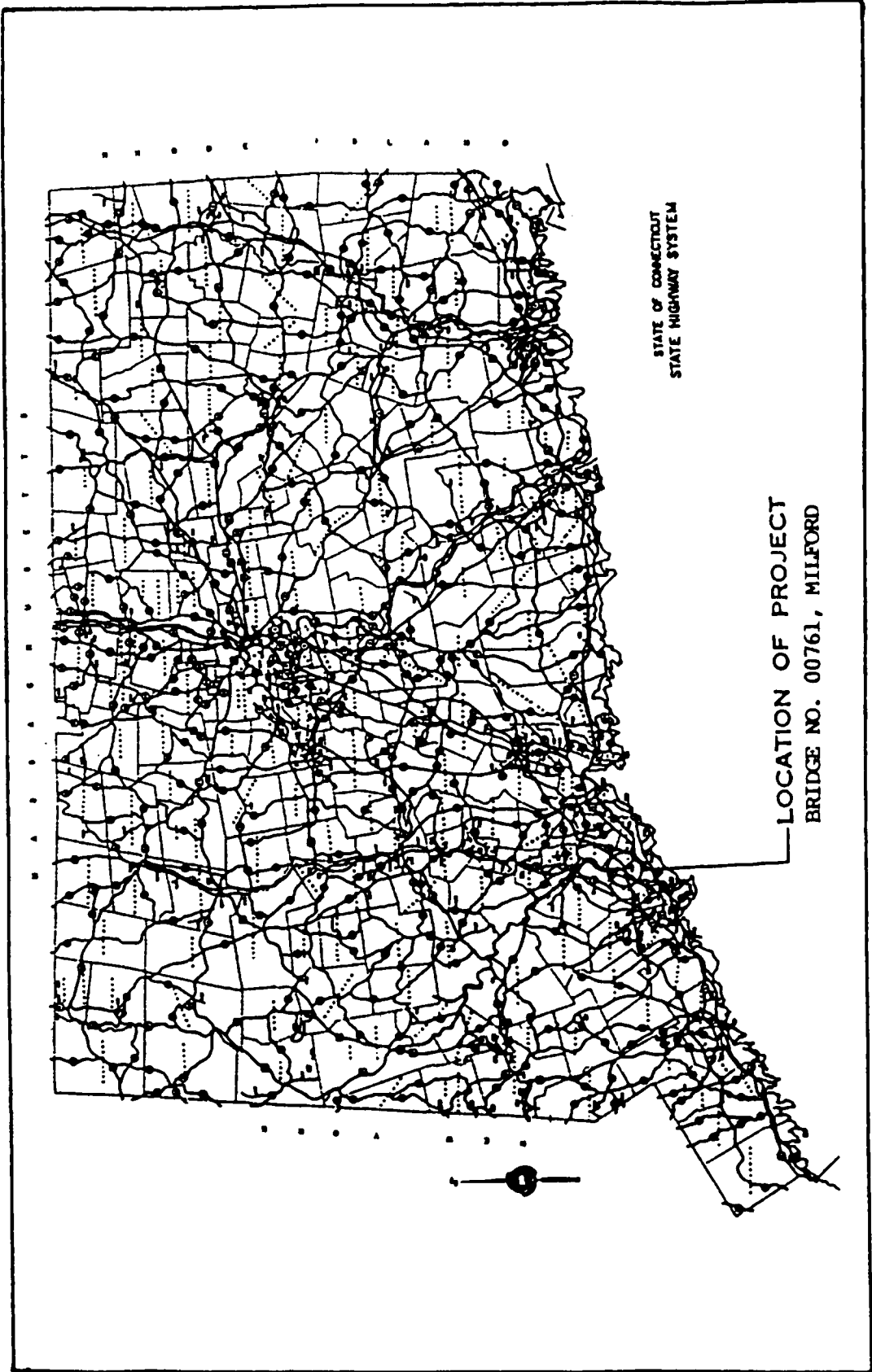

FIG. 13.-Location Map, Bridge No. 00761, Milford

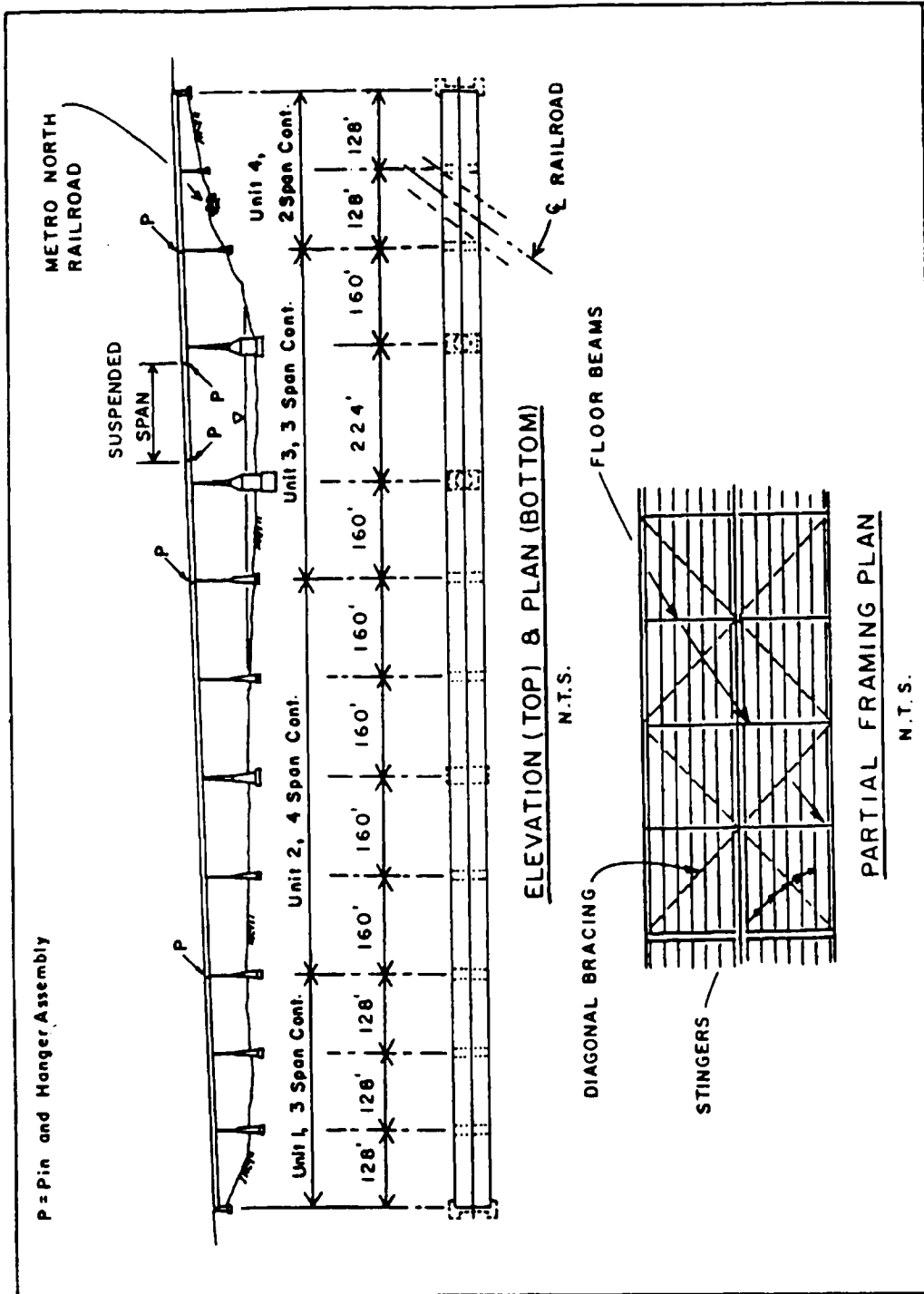
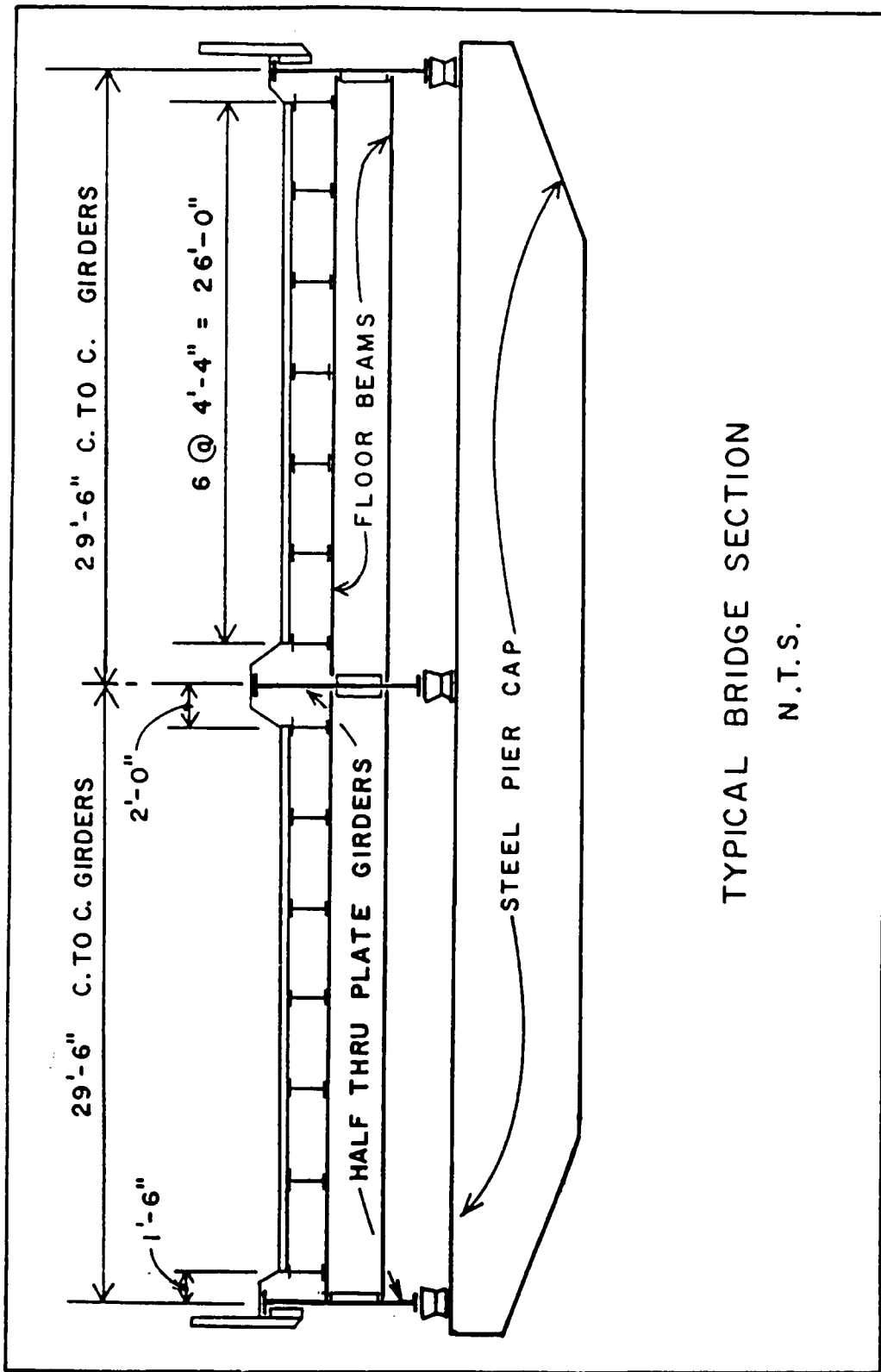

FIG. 14.-Plan, Elevation and Partial Framing Plan, Bridge No. 00761, Milford





TYPICAL BRIDGE SECTION  
N.T.S.

FIG. 15-Typical Bridge Section, Bridge No. 00761, Milford

4. Replacement of all deck grates.

5. Complete painting of the structure.

Construction operations requiring lane closures were limited to off-peak hours beginning at 9:00 P.M. and extending to the following morning. The morning cutoff time varied depending on the day of the week.

This project was designed and bid prior to my assignment with CLE. My involvement began with the preconstruction meeting in November 1986. At that time, ConnDOT's construction staff and the contractor suspected the actual degree and extent of deterioration would require more steel work than was provided for in the plans.

The designers had designated stringer replacements at only eight of the 96 bays. While some provision was made for replacement of deteriorated, but not specifically identified, stringers, the unassigned repair and replacement quantities were minimal.

Based on the scope of work, it was reasonable to believe that a typical grate replacement operation would progress in the following manner:

1. traffic diverted from the work area,
2. existing grates removed,
3. replace those stringers previously designated or judged inadequate on sight,
4. new grates installed.

The contractor proposed and implemented a much different

operation.

The contractor's approach called for preassembling grate-stringer units for modular replacement of a bay, even where no stringer replacements were designated or anticipated. Every stringer on the bridge would be removed; serviceable stringers would be subsequently reinstalled. This allowed the contractor to utilize daytime hours for fabrication of the modular units, limited night allowances could be used most effectively. This innovative approach proved beneficial to both the contractor and ConnDOT.

Shortly after work began, the advantages of modular replacement were realized. Not only could the actual replacement operation be accomplished within the off-peak time allowance but, during the day, stringers removed during the previous night could be sand blasted and evaluated by ConnDOT personnel for possible reuse. That determination could be made without the pressure of limited time, poor accessibility and limited visibility.

As stringers were removed and examined, the top flanges and webs of many were found to be badly deteriorated. After replacing three bays it was obvious that the steel repairs and replacement had been underestimated in the Evaluation Report. Furthermore, the as-bid contract documents provided insufficient guidance for field repair and replacement decisions.

For the first three bays, only four stringers were judged suitable for reuse, none of the 21 had been previously identified for replacement. Unplanned repairs had been ordered on every floor beam. Inspection personnel were placed in the position of accepting or rejecting members for reuse based on intuition. It was also apparent that authorized funds would be insufficient to complete the work and material stocks would soon be exhausted. The Office of Construction called a meeting to address these problems.

At the meeting, ConnDOT's construction staff advised Bridge Design of the foregoing and requested that additional guidance be provided. More realistic quantity estimates and concurrence with projected cost overruns were also requested of the design staff. Although the construction staff may properly order adjustments to plan quantities to meet field requirements, significant modifications should be initiated or concurred by the design staff. Finally, it was requested that a schedule of single lane closures be developed to provide the contractor with an opportunity for miscellaneous steel repair and painting work during the day. As the CLE representative at the meeting, I was directed by the Manager of Bridge Design to develop recommendations for his review.

For the ensuing four weeks this project consumed approximately 50 percent of my time. First the design

consultant was directed to conduct an inspection of the structure using a truck-mounted, hydraulically-actuated, inspection platform (snooper).

Deterioration-based criteria for stringer replacements and repairs and floor beam repairs were developed by the consultant. Because of the traffic limitations, the live load configuration was H-15. Based on the snooper inspection, it was estimated that 60 percent of all stringer replacements would be required.

The cost of the additional work was estimated at \$2.8 million. The original construction contract was \$4.6 million.

Concurrently, an analysis of the traffic was being conducted. The Office of Tolls and Concessions was able to furnish current, hourly traffic volumes for all approaches to the bridge. Based on those data and allowable lane service volumes, recommendations for day closures were developed. I recommended that the extended work hours not be made a part of the contract. This would permit the State to adjust or terminate the allowances solely at their discretion. These recommendations were reviewed by the Office of Tolls and Concessions and Division of Traffic; they concurred.

As construction progressed an uncommon number of change orders were required for this project. In addition to the stringers and floor beams, other significant items such as

a cracked abutment, "binding" girders and extensive pier corrosion had been overlooked during preparation of the Evaluation Report only to be discovered during construction. As a result of these oversights the actual project cost may be double the original contract award.

This contract also includes installation of brackets (Figures 16,17) on the 15 pin and hanger assemblies; the girders on this structure are non-redundant. That work has not yet begun.

Construction of this project is approximately 50 percent complete at a time when it was scheduled to be finished. The contractor is not being assessed liquidated damages due to the significant amount of extra work added to the contract.

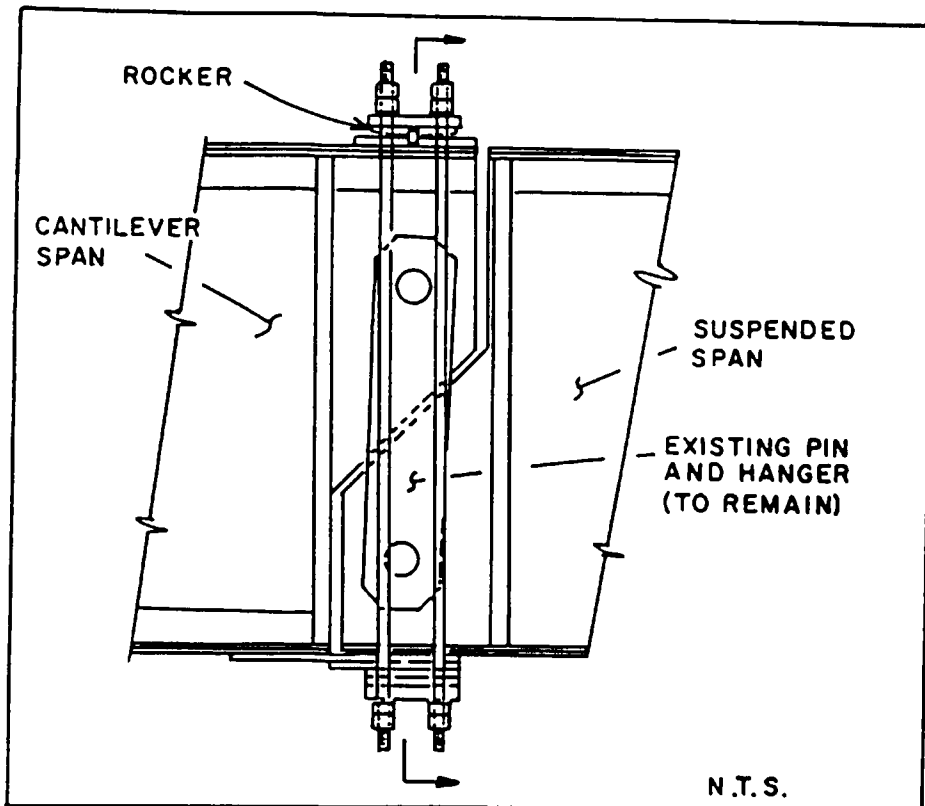

FIG. 16.-Elevation of Pin and Hanger Bracket, Bridge No. 00761, Milford

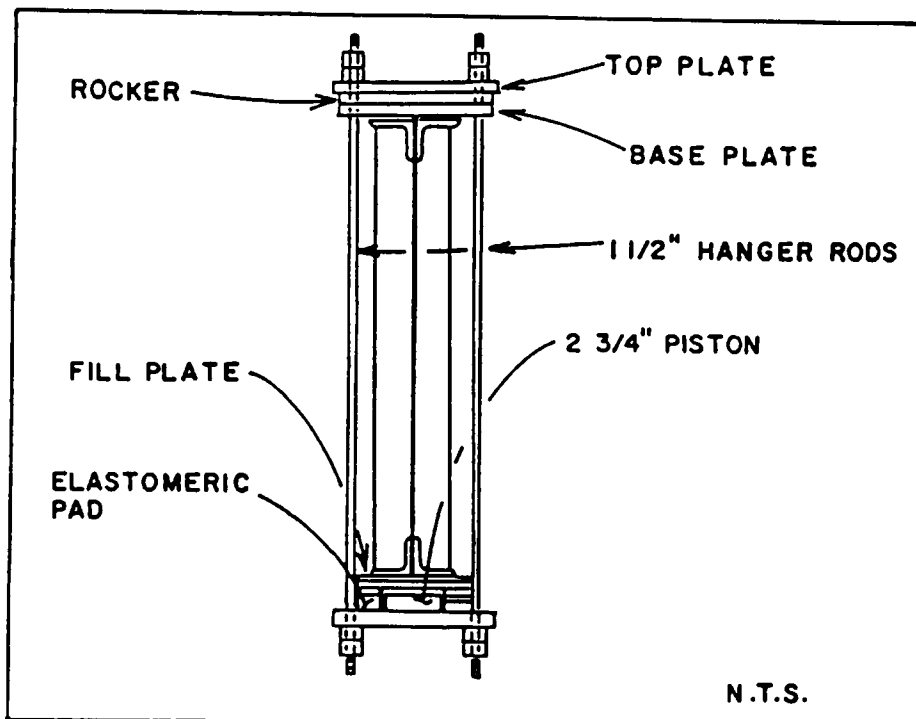

FIG. 17-Section of Pin and Hanger Bracket, Bridge No. 00761, Milford

## CHAPTER VIII

CIVIL GROUP ASSIGNMENT  
GROVE STREET EXTENSION PROJECT

## Background

The Grove Street Extension is a proposed transportation corridor in White Plains, New York. This project has been actively pursued by the City of White Plains (City) and the New York State Department of Transportation (NYSDOT) for over 20 years. Physically, the roadway will extend the one-way pair of Grove Street and Lexington Avenue northwesterly to the intersection of Central Park Avenue and Tarrytown Road (Figure 18).

The total project length is approximately one half mile. The corridor contains a grade separation under two sets of Metro-North Commuter Railroad Company tracks, crosses the Bronx River and its adjacent flood-plain park and intersects or interchanges with the Bronx River Parkway. The project will impact recreational land and historical property thereby requiring special consideration and documentation. The project will also involve relocation of the Bronx River Parkway eastward of its current alignment.

The City considers implementation of this project vital to the continued growth of the Central Business District.



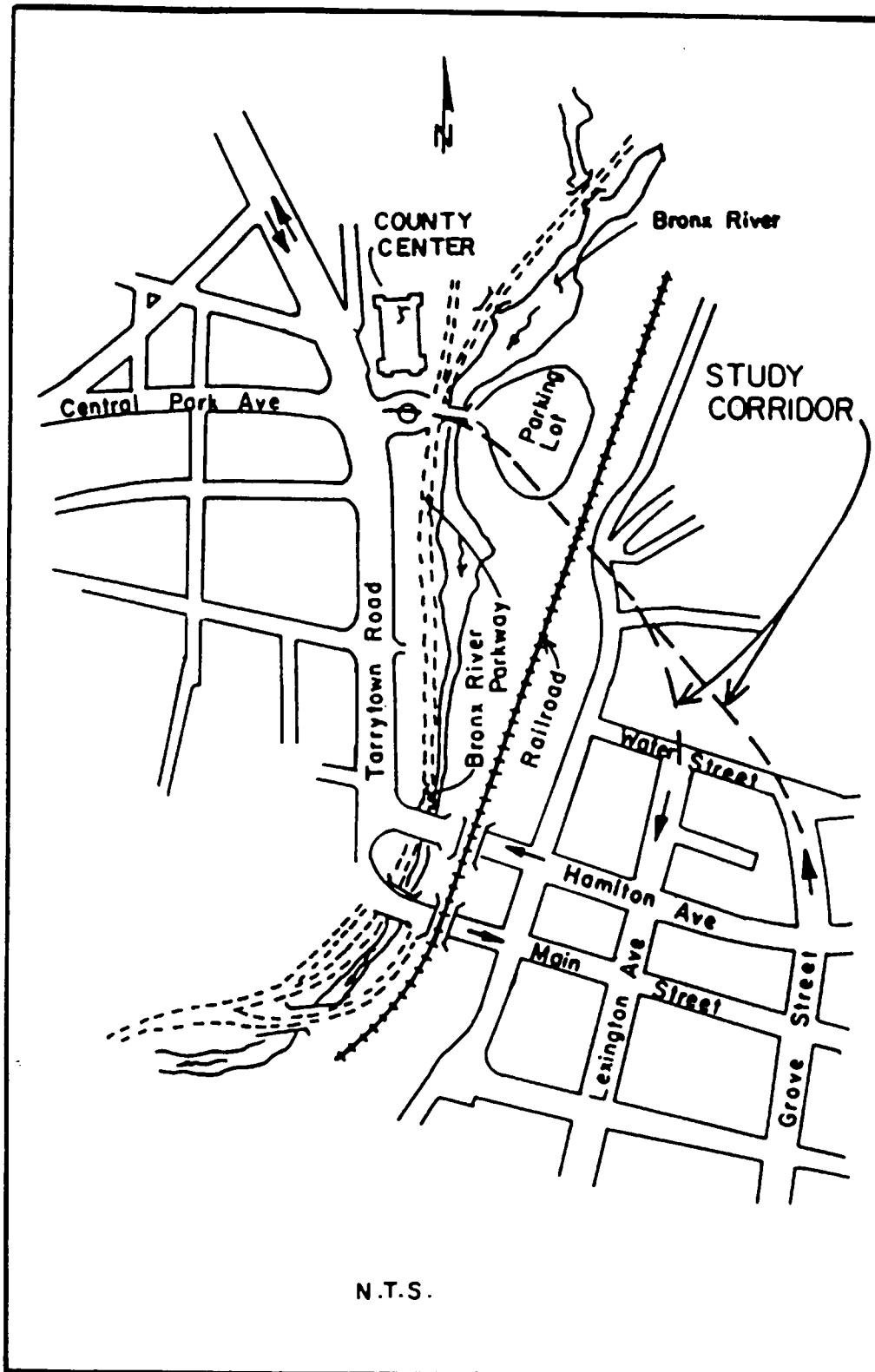

FIG. 18.-Project Area Map, Grove Street Extension, White Plains, New York

Greiner's scope is to provide preliminary design, traffic engineering, cost estimates, draft and final Environmental Impact Statements (EIS) and other documents required by NYSDOT and FHWA to obtain Design Approval.

Prior to Greiner's involvement with the project, another consultant contract for the same scope was terminated by the City after seven years because the consultant failed to adequately progress the project. The City is funding Greiner's \$450,000 fee without assistance or intended reimbursement.

No funding mechanism has been identified for the eventual construction, estimated to begin in 1995 at a 1986 cost of approximately \$40 million. At such time as Design Approval is granted, the City is intending to apply political pressure to the State of New York to fund final design and construction. Presently, the City and NYSDOT are cooperating under the terms of a memorandum of agreement in which NYSDOT has committed staff resources to cooperating with the City's consultant during preliminary design and preparation of the EIS.

#### Scope of Services

The following is a partial list of tasks included in Greiner's contract:

- Survey and mapping
- Review and revise traffic data
- Identify constraints

Develop alternatives  
Assess utility impacts  
Develop structural alternatives  
Analyze hydrology and flooding  
Prepare construction cost estimates  
Assess air quality impacts  
Assess noise impacts  
Assess water quality impacts  
Develop stream modification plans  
Assess wetland impacts  
Assess flood plain impacts  
Prepare 4(f) statement  
Prepare 6(f) statement  
Coordinate advisory agency review  
Conduct public hearing  
Select recommended alternative

The expected duration of this project is 40 months. However, approximately 75 percent of the work will be accomplished in the first 12 months.

This project is being undertaken jointly by the Wallingford and Tampa offices of Greiner. The lead role was originally held by Tampa but subsequently transferred to Wallingford. Certain specialized analyses, such as air, noise and water impacts, will be performed in Tampa. The remainder of the work will be done in Wallingford.

## Role and Activities of the Intern

Beginning in May 1987 I became involved with this project on a part-time basis. As project engineer I reported to the project manager and was responsible for overall technical development in Wallingford and certain management functions.

Early in the project we were told that, despite seven years of work, the previous consultant had never adequately addressed the geometric feasibility of the corridor. I was assigned the task of making that determination. Using criteria established by NYSDOT in 1985 specifically for this project, I developed preliminary plans and profiles to ascertain if those criteria were achievable.

All horizontal criteria were met. Vertical design controls are the railroad tracks, Bronx River Parkway, the Bronx River flood plain and existing termini. Applying NYSDOT and AASHTO Green Book (22) design policies it was determined that the vertical clearance criterion of 16'-6" could not be achieved unless the flood plain clearance was reduced below desirable.

This information was turned over to NYSDOT for evaluation. Subsequently a waiver of the 16'-6" requirement was issued, a reduction to 14'-6" would be permitted.

The only real options associated with this project involve control of access between the Bronx River Parkway

and Grove Street Extension. Several alternative intersection and interchange configurations will be evaluated. Early indications are that an Urban Interchange will be recommended.

The Urban Interchange is a unique facility, originally developed by Greiner, that allows high-volume movements with minimal spatial requirements. Compared to a conventional diamond interchange, the structure cost of the Urban Interchange is higher due to a requirement for a long, deep, single-span bridge, full height abutments and retaining walls. However, where rights of way are limited and high volumes must be accommodated, this design has proven cost effective.

Other options are an at-grade intersection, conventional diamond and internal diamond interchanges. The latter may be dismissed on the grounds that it violates expectancy.

Because of Greiner's location relative to the project area, it was decided that the survey and mapping task should be performed by a subconsultant closer to the site. I was given the opportunity of negotiating the subconsultant's scope and fee. I also drafted the subconsultant agreement.

Other activities on this project include attendance at monthly meetings with the City and NYSDOT, preparation of personnel projections and schedules and immediate oversight

of work performed by the Wallingford staff.

#### PROPOSAL PREPARATION

As part of my involvement with the Civil Group, I assisted in the preparation of technical and cost proposals for a multi-discipline engineering contract. The proposal is for preliminary engineering of a multi-use shoreline development in East Haven, Connecticut.

The developer intends to construct a mixed-use facility to include condominiums, cabanas, a beach club and conference hotel. The property includes many sensitive environmental features including certain coastal resources specifically protected by statute. Thus the developable land is a fraction of the total property.

To assist in the project development and preparation of the proposal, a meeting was held between the regulatory staff and members of the developer's project team. It was immediately obvious that the developer's goals and those of DEP were in conflict. The intensity of land use as presented by the architect was far greater than DEP will permit.

A significant portion of Greiner's activities will involve delineating the developable portion of the property and designing a plan acceptable to both developer and regulator. The proposed work includes traffic studies, hydrology, hydraulics, civil design, environmental and coastal engineering.

The proposal is pending review by the developer.

## CHAPTER IX

### CONCLUSION

Based on the activities described in this report, I believe all objectives stated in the Internship Proposal have been accomplished.

The engineering and non-engineering courses included in my degree plan were excellent preparation for the duties associated with the internship and future responsibilities in the civil engineering profession.



## REFERENCES

1. Mahoney, K.M., "Civil Engineering Activities at Greiner Engineering Sciences," internship proposal, Texas A&M University, College Station, TX, August 1986.
2. Greiner Engineering, Inc., "Annual Report 1986," Irving, TX, 1987.
3. Connecticut, Special Act No. 80-79, Hartford, CT, May 1980.
4. "Connecticut Master Transportation Plan," Connecticut Department of Transportation, Wethersfield, CT, December 1983.
5. Connecticut, Public Act No. 83-30, Hartford, CT, June 1983.
6. Zetlin-Argo Structural Investigations, Inc., "Final Report, Collapse of a Suspended Span of Interstate Route 95 Highway Bridge Over the Mianus River, Greenwich, Connecticut, June 28, 1983," December 1984.
7. Connecticut, Special Act 85-101, June 1985.
8. Gubala, R.W., "Connecticut's Comeback Bridge Renaissance," Proceedings of the 4th Annual International Bridge Conference, Pittsburg, PA, June 1987.
9. Connecticut, General Statutes, Section 13a-126.
10. "Highway Drainage Guidelines," American Association of State Highway and Transportation Officials, Washington, DC, 1982.
11. Connecticut, General Statutes, Section 13a-94.
12. Connecticut, General Statutes, Section 22a-342.
13. Connecticut, Executive Order No. 18, March 1978.
14. "Drainage Manual," Connecticut Department of Transportation, Wethersfield, CT, January 1983.

15. "Runoff Estimates for Small Rural Watersheds and Development of a Sound Design Method," Report No. FHWA-RD-77-159, Federal Highway Administration, Washington, DC, December 1977.
16. Weiss, L.A., "Evaluation and Design of a Streamflow-Data Network for Connecticut," Connecticut Water Resources Bulletin No. 36, U. S. Geological Survey, Hartford, CT, 1983
17. Shearman, J.O., "Computer Applications for Step-backwater and Floodway Analyses," U.S. Geological Survey Open File Report 76-499, Washington, DC, 1976.
18. "WSP2 Computer Program," Technical Release No. 61, Engineering Division, Soil Conservation Service, U.S. Department of Agriculture, May 1976.
19. "HEC-2, Water Surface Profiles, Users Manual," U.S. Army Corps of Engineers, Hydrologic Engineering Center, Davis, CA, September 1982.
20. Connecticut, General Statutes, Section 13b-251.
21. "Geometric Highway Design Standards," Connecticut Department of Transportation, Wethersfield, CT, November 1976.
22. "A Policy on the Geometric Design of Highways and Streets," American Association of State Highway and Transportation Officials, Washington, DC, 1984.
23. "Recording and Coding Guide for the Structure Inventory and Appraisal of the Nation's Bridges," Federal Highway Administration, Washington, DC, January 1979.
24. T. Y. Lin International, "Condition Report and Evaluation Report, Route 341 over the Housatonic River, Kent, Connecticut, August 1984.
25. "Master Transportation Plan, 1987," Connecticut Department of Transportation, Wethersfield, CT, December 1986.
26. Connecticut, General Statutes, Section 13a-57.
27. Connecticut, General Statutes, Section 13a-73.
28. Connecticut, General Statutes, Section 13a-98.

**APPENDIX A**  
**INTERNSHIP PROPOSAL**

**Civil Engineering Activities  
at Greiner Engineering Sciences**

**An Internship Proposal**

**by**

**Kevin M. Mahoney**

**Submitted to the College of Engineering  
of Texas A&M University**

**in partial fulfillment of the requirements  
for the degree of**

**Doctor of Engineering**

**August 1986**

**Major Subject: Civil Engineering**

Civil Engineering Activities  
at Greiner Engineering Sciences

An Internship Proposal

by

Kevin M. Mahoney

Approved as to style and content by:

---

Dr. Wesley P. James, Chairman  
Student's Advisory Committee

---

Dr. James S. Noel, CVEN  
Committee Member

---

Dr. Dallas N. Little, Jr., CVEN  
Committee Member

---

Dr. David A. Dubofsky, FINC  
Committee Member

---

Dr. Clayton C. Nelson, MEEN  
College of Engineering Rep.

---

Dr. Martha R. Scott, OCNG  
Graduate College Rep.

---

Dr. Carl A. Erdman, Assoc. Dean  
College of Engineering

---

Mr. Allen V. Herring, Greiner  
Internship Supervisor

## TABLE OF CONTENTS

Section	Page
Introduction	1
Intern's Position with Organization	1
Internship Objectives	6
Internship Supervisor	6

## LIST OF FIGURES

Number	Title	Page
1	Partial Organizational Chart of Greiner/Wallingford	2

## I INTRODUCTION

The Doctor of Engineering Degree at Texas A&M University requires that the candidate complete a Professional Internship (ENGR 684) with an organization engaged in engineering activities. To that end, I am proposing that I serve my internship at Greiner Engineering Sciences in Wallingford, Connecticut, for the 12 month period beginning September 1986.

Greiner is headquartered in Irving, Texas, with offices throughout the U.S. and limited overseas operations. They were ranked as the 33rd largest consulting firm by Engineering News-Record (1). Greiner is engaged in a wide variety of civil engineering activities.

## II INTERN'S POSITION WITH ORGANIZATION

Greiner has adopted the ASCE's guidelines (2) for classifying engineers, a copy of those guidelines has been appended to this proposal. My classification during the internship will be Engineer IV. This position will provide me ample opportunity to participate in the technical and administrative functions of a consulting firm. During the course of my internship it is probable that I will successively be given two distinct assignments.

The first assignment will be as a member of Greiner's Connecticut Department of Transportation (CONNDOT) Consultant Liaison Engineer (CLE) Group and is expected to run from September 1986 through April 1987. The second will be as a project engineer in the Civil Group. Both positions are at Greiner's Wallingford office. An organizational chart of Greiner/Wallingford has been included here as Figure 1. The

Figure 1. Partial Organizational Chart of Greiner/Wallingford

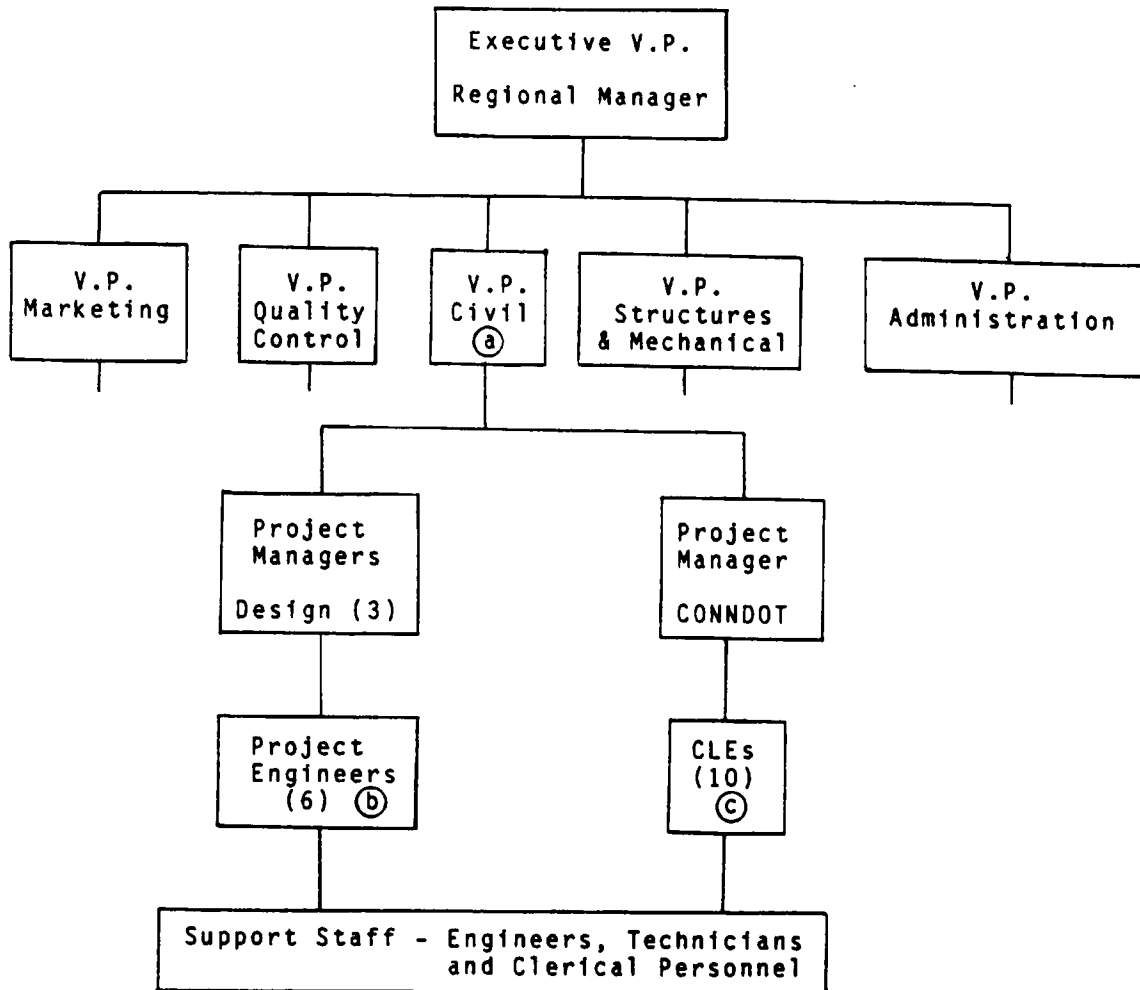

(a) Internship Supervisor - Mr. Allen V. Herring

(b) First internship assignment

(c) Second internship assignment

( ) Number of personnel in category



anticipated technical and administrative duties of each role are described in the following subsections.

#### CLE Assignment

The State of Connecticut, through CONNDOT, is currently pursuing an aggressive emergency bridge replacement program and is engaging a number of consultants to provide design services. The large number of bridge replacements has overtaxed CONNDOT's capacity to effectively administer all of its projects. Greiner has been contracted by CONNDOT to act as their general consultant and to assist them in activities that would normally be accomplished by CONNDOT inhouse.

Prior to an agreement between the design consultant and CONNDOT, the general consultant will review the fee proposal, discuss its contents with the design consultant and advise CONNDOT as to its acceptability. After an agreement has been reached between the client-owner (CONNDOT) and the consultant, the general consultant will review the activities of the designer with respect to technical quality and completeness, conformance to prescribed standards for plan preparation, completion-schedule targets and invoices for completed work. Prior to advertising and construction, the CLE is responsible for utility and right-of-way coordination and agreements.

The CLE is composed of several two-engineer teams, each team consists of a civil engineer and a structural engineer; I will be a civil engineer team member. Although Greiner is expected to provide competent, general technical review of projects, an individual CLE engineer will not ordinarily have the breadth of

expertise, nor the available time, to accomplish this task independently. Therefore, Greiner's professional and technical staff will assist the CLE in the review of projects on an as needed basis.

Typically, the civil engineer's review will include: geometrics, drainage, pavement, surface hydrology, traffic operations, utilities, right-of-way, maintenance of traffic and cost considerations. To be most effective, the civil engineer will augment his current expertise in several of these areas with additional technical development acquired from consultation with inhouse experts.

The administrative duties of the CLE are many and varied. The civil engineer is the team leader and has the responsibility for all correspondence and the overall coordination of the project. On a given project there is a near-constant exchange of information between CONNDOT, the design consultant and Greiner's staff involved with the review; the CLE engineer must control the flow of that information. Other duties will include: encouraging the design consultant to make submittals on schedule, ensure that reviews are conducted in a thorough and timely manner, present review comments and recommendations to the design consultant and appraise CONNDOT of germane developments.

#### Civil Group Assignment

The Civil Group at Wallingford provides a wide variety of consulting services to public and private clients in the northeastern U.S. Typical contracts may be categorized as: public works, land development, stormwater management, surveying,

hydrologic studies, highway design and airport engineering.

A project engineer is responsible for the day-to-day technical and administrative duties necessary to provide the required services at a cost consistent with the budget. If the subject services were a hydrologic/hydraulic analysis of a region, the product is generally a report of the findings and presentation of supporting data. On the other hand, a public works assignment typically requires that the consultant develop a design, prepare contract documents (plans and specifications) and in some cases oversee the bidding process and construction phase services.

The project engineer for a particular contract is selected with the expectation that he will provide technical direction to the project and provide. He must also provide daily supervision and direction to the project support staff which includes: junior engineers, technicians and clerical personnel. Although it is often necessary to solicit guidance from experts outside the normal project group, the principle technical leadership should lie with the project engineer and not external sources. As such, I anticipate that during my internship within the Civil Group I will be assigned to transportation and water resources projects.

In addition to the technical requirements incumbent upon me as a project engineer I expect to assist the project manager with proposals, fee estimates, staffing assignments, scheduling and budget reviews. In many instances it is necessary for the project engineer to play the primary role in securing the approval of regulatory agencies which have jurisdiction over a

project. These agencies may be concerned with any or all of the following: environmental protection, stormwater management, transportation, planning and zoning and public utilities. To gain approval will generally require conferences with agency staff, and in many cases, a public presentation to the governing body.

### III INTERNSHIP OBJECTIVES

The following are my objectives for the Professional Internship:

1. Apply my academic training and previous experience in civil engineering to the preparation of designs and studies.
2. Review and assess the quality of professional engineering services performed by other organizations.
3. Effectively coordinate the activities of peers and subordinates to meet schedule and budget constraints.
4. Develop the communication skills necessary to:
  - a. present the results of technical evaluations to parties with varying degrees of expertise.
  - b. establish and maintain a harmonious relationship with clients and coworkers whenever possible.
  - c. convince others of the benefits of modifying their position on an issue.
5. Participate in the project procurement process by assisting in the development of technical and price proposals.

### IV INTERNSHIP SUPERVISOR

The proposed internship supervisor is Mr. Allen V. Herring. Mr. Herring began his engineering career with EXXON and has been with Greiner for the past 15 years. He has considerable experience in water resources, transportation, public works and land development. In addition to his technical expertise, Mr. Herring is a vice president and manages the Civil Group at Wallingford, a copy

of his resume is attached.

**REFERENCES**

1. Engineering News-Record, The Top 500 Design Firms, New York, NY (May 15, 1986)
2. ASCE Guide to Employment Conditions for Civil Engineers, ASCE Manuals and Reports on Engineering Practice No. 55, New York, NY (1977)

**APPENDIX B**  
**INTERNSHIP REPORTS**

**Greiner**

Greiner, Inc.  
20 Alexander Drive  
Wallingford, Connecticut 06492-2430  
(203) 265-6741

---

To: Dr. Wesley P. James

September 30, 1986

From: Kevin Mahoney

Reference: Professional Internship, ENGR 684  
Report No. 1

This is the first of my monthly reports which will summarize pertinent activities and progress toward my objectives. Those objectives were outlined in my Internship Proposal which has been approved by the College of Engineering and the Graduate College. In this initial report I will give an overview of my first assignment; in subsequent reports, I plan to describe my participation in the various activities.

I began my Internship on September 2, 1986 and as anticipated was assigned to Greiner's contract with the Connecticut Department of Transportation's (ConnDOT) Emergency Bridge Program. Greiner is ConnDOT's Consultant Liaison Engineer (CLE), and while transportation agencies frequently retain private firms for design and specialized expertise, the role of the CLE is rather unique. The CLE may be described as a temporary expansion of ConnDOT's manpower and facility resources. It is our duty to act in the state's behalf in their dealings with consulting engineers (CEs), regulatory agencies, railroads, construction contractors, landowners, local officials and concerned citizens.

Because this is an emergency program, time is critical and many normal practices have been suspended. One of the most evident distinctions is the compensation arrangement that ConnDOT has with the CLE and CEs. Typically, transportation design contracts provide for a well-defined scope of services in exchange for a fixed fee. However, in the emergency program, the scope of work may be ill-defined and the intrinsic urgency does not lend itself to a prolonged negotiation process. The financial benefits of this arrangement to the contracting engineer is obvious. This relationship also permits ConnDOT to issue work directives for the revision and expansion of consultant's duties without concern for compromising schedules caused by the need for contract supplements.

The bridges themselves are of many types; functionally they include: highway-highway grade separations, highway-rail grade



# Greiner

separations, over-harbor bridges and river and stream crossings. Existing structures may be cast-inplace concrete, steel girders, trusses or concrete box culverts. Remedial work varies from deck repairs to superstructure replacement to complete replacement. Replacement structures may be precast box culverts, prestressed voided slabs, prestressed beams, steel girders, steel box girders or concrete box girders.

Important considerations in design development are maintenance and protection of traffic, safety, environmental protection, right of way requirements, preservation of historical resources and impact on utilities. In the ensuing months, I will expand on these topics as they relate to my duties and the achievement of the Internship Objectives.

cc: Mr. Allen V. Herring, GES  
Dr. James S. Noel, TAMU

**Greiner**

Greiner, Inc.  
20 Alexander Drive  
Wallingford, Connecticut 06492-2430  
(203) 265-6741

---

To: Dr. Wesley P. James

October 31, 1986

From: Kevin Mahoney

Reference: Professional Internship, ENGR 684  
Report No. 2

October was the second month of my internship and assignment to ConnDOT's Emergency Bridge Program. My day-to-day activities include general responsibility for 37 bridges in all phases of completion. Several of my assigned bridges are in the very preliminary stages, construction is nearly complete on others. As a general rule, the complicated bridge replacements are still some time away from construction; on the other end of the spectrum many rehabilitation projects have been concluded. As would be expected, rehab projects typically do not require the lengthy processes of permits, right of way acquisition and utility relocation agreements.

In some cases rehab projects are stop-gap measures, intended only to provide immediate relief until more permanent restoration or replacement can be accomplished. With other rehabs, no further work is anticipated.

Bridge replacements sometimes involve non-engineering activities that are more cumbersome than the engineering design. I currently have two such projects that are in the early stages of development, they are Bridges Numbers 1594 and 1349 in Kent and Westport respectively. In this report I will address only Bridge 1594 and leave 1349 for a subsequent report.

Kent is a small, rural, affluent community in northwestern Connecticut. The subject bridge carries Route 341 over the Housatonic River which has a design discharge (Q100) of 42,900 cfs at the crossing, there is no tidal influence. The existing structure is a single span, riveted steel, through truss and was constructed in 1923. The concrete deck and steel floor system are badly deteriorated. ConnDOT considered rehabilitating this structure but has proposed replacement on an alignment slightly upstream of the existing bridge. Stage construction is proposed to maintain traffic without a temporary bridge or detour.

The existing bridge is eligible for inclusion on the National

# Greiner

Register of Historic Places. As such, and because federal funds are being utilized, an Environmental Assessment/Section 4(f) Findings Evaluation has been prepared. Another requirement mandated by federal legislation is a public hearing. We are in the process of preparing for that hearing which is scheduled for November 19. The legal notice of the hearing is being published on three occasions in three different newspapers and has also been directly distributed to many interested parties. A copy of the notice and distribution list is attached.

The purpose of the public hearing is to inform the public of the proposed work and some of its possible consequences and to solicit input before selection of the design alternate. Over the past several weeks I have been gathering background information and preparing the narrative for the presentation which will be given by the project manager. The CE (T.Y. Lin International) has been directed to develop several visual aids. Although my contact with local officials has indicated no strong opposition to the replacement as proposed, it is reasonable to believe that impacted landowners and those interested in preservation of the existing bridge on historic grounds may object.

I will report back on this and other activities next month.

Enclosures

cc: Mr. Allen V. Herring, GES  
Dr. James S. Noel, TAMU

**Greiner**

Greiner Engineering Sciences  
P.O. Box 787  
20 Alexander Drive  
Wallingford, Connecticut 06492-2430  
(203) 265-6741

A Greiner Engineering, Inc. Company

To: Dr. Wesley P. James

November 30, 1986

From: Kevin Mahoney

Reference: Professional Internship, ENGR 684  
Report No. 3-----

In my last report I discussed my activities on Bridge No. 1594 in Kent. Although I have worked on a number of projects in November, in the interest of continuity I will limit this report to a status review of the Kent Bridge. The public hearing was conducted on November 19 as scheduled, in preparation for the hearing two dry runs were held at ConnDOT's offices.

At the actual hearing Greiner was responsible for the presentation of design alternatives, the moderator and rights of way agent were ConnDOT representatives. Following the prepared presentations the floor was opened for comments and questions. No speakers opposed the project. Three speakers, including Kent's First Selectman, endorsed the project but asked that certain design features be included. To my surprise ConnDOT's Manager of Bridge Design stated his unequivocal concession to two such requests. Other mandates from the public are under consideration.

The Kent School is a private institution situated on the west bank of the river. The school supports a ambitious sports program which includes rowing. The school's Director of Athletics attended the hearing and among other things requested that the bridge be two spans, not three, and that a pier foundation remnant in the river be removed. Both items would diminish the project's long term impact on the rowing program.

The existing bridge is a single-span structure on tangent alignment within a broken-back horizontal curve. The proposed bridge is curved to improve horizontal geometry and facilitate stage construction. A single-span replacement is most desirable from the school's perspective. However, the curvature ( $R=650'$ ) and 260' length of bridge can be more economically accommodated by multispan construction. Originally, a three-span replacement bridge was proposed but ConnDOT may now opt for a two-span design in consideration of the school's interest. This issue will be addressed during the Type Study.

## Greiner

The school's request to remove the pier remnant gives rise to a sensitive environmental problem. In recent years the existence of PCBs have been detected at various locations in the Housatonic River. We are in the process of setting up a testing program to determine the existence and concentration of PCBs at the project site. If the concentration is between 1 and 50 ppm the Department of Environmental Protection (DEP) will probably issue a permit stipulating the disposition of any excavated materials. For concentrations exceeding 50 ppm, DEP may order that construction activities in the river be curtailed. Since the replacement bridge can be designed and constructed independent of the pier removal, no effort will be expended on this until the testing is complete.

Typically, the design process would not advance until after the 30 day comment period was complete and the public hearing transcript was analyzed. However, due to the favorable comments received at the hearing, ConnDOT has elected to proceed with the design of the recommended alternate. We will be meeting with the CE (T.Y. Lin International) at the site to establish a work program and schedule.

cc: Mr. Allen V. Herring, GES  
Dr. James S. Noel, TAMU

**Greiner**

Greiner Engineering Sciences  
P.O. Box 767  
20 Alexander Drive  
Wallingford, Connecticut 06492-2430  
(203) 265-6741

A Greiner Engineering, Inc. Company

To: Dr. Wesley F. James

December 30, 1986

From: Kevin Mahoney

Reference: Professional Internship, ENGR 684  
Report No. 4

Despite the holidays, December was an active month. The Federal Highway Administration (FHWA) held an onboard review here this month. Among the attendees were the FHWA District Engineer, Manager of Bridge Design, DOT Project Manager and CLE Project Manager. Each Liaison Engineer, including myself, briefed the group on our respective Federal Aid projects. I have four bridges for which federal funds have been committed or are anticipated.

I processed a two-bridge construction contract in December. The project was delayed for several months by right of way negotiations. At one point I modified the design slightly to accommodate a landowner with the understanding that he would accept the State's offer. After the revisions were complete, the landowner reneged. In the end, negotiations were unsuccessful and the required acquisition is in condemnation.

There was a preconstruction conference for a major deck replacement this month, I represented Greiner. The construction contractor (Cianbro Corp.) appears to be aggressive, well managed and proficient. They previously completed the Woodrow Wilson Bridge redecking.

ConnDOT's bridge has a steel grate deck and carries a high volume, limited access parkway over a river. Maintenance of traffic is an important consideration and contract provisions include incentives for early completion and heavy penalties for late completion. At the preconstruction conference Cianbro tabled several proposals that would expedite their activities. Specifically, they want to consolidate the stringer replacement and deck replacement operations. Additionally, they proposed that rehabilitation of floorbeams by bolting angles at the four web-flange corners be accomplished with traffic overhead. The Special Provisions for this project specify that this work is to be done without overhead traffic. Although the proposals sounded reasonable, this project was designed prior to my involvement with the program and therefore I would not submit my unqualified concurrence. The District Engineer directed Cianbro to prepare a

# Greiner

written proposal for review by the design consultant.

Administratively, three CEs submitted invoices in December, I approved two. On the third, I felt that the consultant's estimate of his progress was over optimistic. As a cost-plus agreement, the CEs are paid for actual, authorized expenditures. However, they have a maximum authorization level and are required to estimate their percent complete with each invoice. In this particular case, I have advised the consultant that I disagree with his estimate of percent complete and have asked him to submit drawings to substantiate his claim.

cc: Mr. Allen V. Herring, GES  
Dr. James S. Noel, TAMU

**Greiner**

Greiner Engineering Sciences  
P.O. Box 767  
20 Alexander Drive  
Wallingford, Connecticut 06492-2430  
(203) 265-6741

A Greiner Engineering, Inc. Company

To: Dr. Wesley P. James

January 30, 1987

From: Kevin Mahoney

Reference: Professional Internship, ENGR 684  
Report No. 5

My activities in January included a number of administrative and technical functions, I will discuss five projects in this report. Bridge No. 111 carries I-95 over Bridgeport Harbor. The combination of high traffic volumes (ADT = 110,000) and passage of water-borne vessels below this structure have caused much concern. The rehabilitation work includes structural steel repairs, bearing replacements and pin and hanger replacements. The last item will require highway lane closures. This month we have had several meetings to discuss how best to accommodate the space requirements of the contractor and efficient passage of highway and harbor traffic. Tentatively, we are proposing that lane closures be allowed at night only and that stiff penalties be assigned to the contractor for his failure to restore all lanes by 5:30 AM. I have also been communicating with the Coast Guard, attempting to gain their approval of this project. In this case, the Coast Guard's jurisdiction involves only activities that affect navigation. It now appears that they will approve the project pending receipt of information from the successful bidder regarding schedules and the specific equipment and methods to be employed. The Coast Guard has made numerous other stipulations which will in turn be included as part of the contract documents.

This month I prepared a civil review of Bridge No. 785. This project involves the rehabilitation of a Merritt Parkway (limited access) bridge over the Mill River. It is a superstructure replacement and will require retrofitting the abutments to accommodate prestressed concrete deck units. The Maintenance and Protection of Traffic Plan was developed to provide for uninterrupted service during the three stages of construction. Following my review and another by a structural engineer I met with the CE to discuss the comments. The CE will proceed with preparation of the Semi-Final Submission.

In previous reports I have discussed my activities on Bridge No. 1594 in Kent. This month I prepared an analysis of the



# Greiner

public hearing transcript. This analysis is presented in the form of a letter from the Commissioner of Transportation to the mayor or first selectman of the community in which the project is located. Basically, this letter is a recapitulation of the hearing itself, any comments received by mail, the principle issues involved and a statement of DOT's intended action. This analysis has been forwarded for review by DOT staff and eventual signing by the Commissioner.

Also in January, I reviewed a drainage/hydraulics submission for Bridge No. 618. Overall, the CE did a good job. The plans and computations have been returned for the appropriate revisions and resubmittal.

Bridge No. 782 is a grade separation where the Merritt Parkway passes over a railroad and highway. The proposed rehabilitation work includes replacement of pin and hanger assemblies and converting a steel, composite cross girder to non-composite. The contractor, through a consulting structural engineer, has developed an intricate plan for jacking the cross and longitudinal girders. I have reviewed the plan from a highway and rail vantage, it is currently under review by a structural engineer.

At the end of November, the contracts between the State and CEs expired. Since the work covered under those agreements had not been completed, all parties sought to extend the life of the contracts through supplemental agreements. However, rather than simply extend the original agreement, the State included additional provisions. One such provision was a requirement for additional liability insurance coverage. Some CEs found this clause so disagreeable that they refused to sign the agreement, others signed under protest. Subsequently, the State removed the clause in the unsigned agreements and rescinded the requirement in those agreements where the CEs had signed under protest. Interestingly, for those CEs that signed and did not protest, the insurance requirement was not rescinded.

I have reviewed my overall progress toward my Internship Objectives and feel that substantial progress has been made on all of them except, participation in the development of proposals. My Internship Supervisor and I feel that opportunities for that activity will be forthcoming.

cc: Mr. Allen V. Herring, GES  
Dr. James S. Noel, TAMU

**Greiner**

Greiner, Inc.  
20 Alexander Drive  
Wallingford, Connecticut 06492-2430  
(203) 265-6741

---

To: Dr. Wesley P. James

February 28, 1987

From: Kevin Mahoney

Reference: Professional Internship, ENGR 684  
Report No. 6

In the beginning of February I processed a three-bridge contract for construction. That procedure was complicated by several factors, one of the three bridges has federal participation which creates additional administrative work. Additionally, the estimated number of calendar days required to complete construction very nearly equals the number (244) in a single construction season. To avoid having construction done in two seasons, work must begin by April 15. Normally, the elapsed time from processing to the beginning of construction is 20 weeks. In this case it will be reduced to nine weeks.

The I-95 crossing of Bridgeport Harbor (Bridge No. 111) is nearing design completion. The project entails pier patch work, structural steel repairs and pin and hanger replacements. The structural design has not been a problem. Developing a Maintenance and Protection of Traffic Plan has presented the designer with considerable difficulty. This month, I attended two meetings with designer and ConnDOT to develop a workable plan. Coordination with railroad for this project was also initiated this month.

I met with a consultant this month regarding his fee invoices. Although CEs are paid on the basis of authorized expenditures and not productivity they are still required to report production progress. This allows the CLE to foresee possible budget shortfalls and take appropriate action. When the invoices were first submitted, I could not concur with his estimate of production. The CE was then notified that his invoices were not approved and was requested to submit plans, specifications and estimates. After reviewing this material, the invoices were approved.

I reviewed several requests for work directive modifications this month. In most cases the consultant has sufficient justification for additional compensation, either the scope of work has been increased or the his original estimate was too optimistic. Cost over-runs can also occur as a result of

## Greiner

inefficiency and abuse. Of the three such requests that I reviewed this month, I recommended approval of two and disapproval of a third.

A meeting was held here this month to discuss various right of way considerations. The following groups were represented: Rights of Way (ConnDOT), Design (ConnDOT), Bridges and Structures (ConnDOT), the consultant, the subconsultant and the CLE. The particular project (Bridge No. 618) involves a roadway realignment and creation of a "reclaimed inland wetland." The latter has been requested by the Dept. of Environmental Protection as compensation for displacing wetlands with highway construction. It was a productive meeting but one issue was left unresolved. We do not know if it is legal for ConnDOT to condemn and acquire land beyond that necessary for the actual roadway and appurtenances. A policy decision on this is pending.

cc: Mr. Allen V. Herring, GES  
Dr. James S. Noel, TAMU

**Greiner**

Greiner Engineering Sciences  
P.O. Box 767  
20 Alexander Drive  
Wallingford, Connecticut 06492-2430  
(203) 265-6741

A Greiner Engineering, Inc. Company

To: Dr. Wesley P. James

March 31, 1987

From: Kevin Mahoney

Reference: Professional Internship, ENGR 684  
Report No. 7

This month, I was very involved with administrative matters on CLE. I met with two consultants to discuss changes in the scope of their assignments and supplemental agreements to increase their fees.

The construction startup is approaching and notices to proceed will soon be issued to contractors for projects that were awarded during the winter shutdown. This has led to a number of requests by ConnDOT Construction for expeditious conclusion of change orders, rights of entry and easements.

The replacement of Bridge No. 618 is currently under design and involves a significant realignment of Route 8 and its intersection with a local road. In March, ConnDOT's Project Manager and I met with affected landowners and the First Selectman to explain the proposed work and solicit their input.

Bridge No. 564 carries Route 7 over the Hollenbeck River, a replacement structure has been designed. The project was scheduled for a June advertising, but that will no longer be possible. The Environmental Protection Agency (EPA) has requested that the Corps of Engineers not issue a permit unless certain design modifications are made. EPA has asked that jute mesh be used at all locations where rip rap was to have been placed. ConnDOT's policy is to rip rap all disturbed banks. EPA's request, if granted, would provide the approach embankment with less protection against scour. It appears that both parties are amenable to compromise, but the issue is currently unresolved.

The plans for the repair of Bridge No. 111 are nearly complete. Included in the work is the replacement of pin and hanger assemblies. Because the suspended span is over the harbor, jacking must be from above and in the travel lanes. ConnDOT's Division of Traffic has dictated that lane closures will be allowed at night only and then for a maximum duration of eight hours. The consultant is skeptical that a pin and hanger assembly can be replaced in that amount of time. A key, time-

# Greiner

consuming subtask is painting the existing girder web behind the hanger plates. By ConnDOT policy, all corrosive surfaces are to be protected with three coats of paint; an underlying coat must be dry before application of a subsequent coat. I am currently investigating what, if any, methods have been used by ConnDOT to contend with similar constraints. Hopefully, a field-proven, accelerated drying paint or an other-than-paint protector is available.

I completed a final civil review of Bridge No. 785 this month. The project entails a superstructure replacement with prestressed concrete box beams. A Bridge Review Engineer and myself then met with the consultant's design staff in their office to discuss our comments. That project is scheduled for May advertising.

Late in March, a contract was signed between Greiner and the City of White Plains for the Grove Street Extension project. Greiner will be preparing an EIS and planning reports. I expect my involvement with that project to become fulltime in approximately one month.

cc: Mr. Allen V. Herring, GES  
Dr. James S. Noel, TAMU

**Greiner**

Greiner Engineering Sciences  
P.O. Box 767  
20 Alexander Drive  
Wallingford, Connecticut 06492-2430  
(203) 265-6741

A Greiner Engineering, Inc. Company

To: Dr. Wesley P. James

April 30, 1987

From: Kevin Mahoney

Reference: Professional Internship, ENGR 684  
Report No. 8

This month my time was divided between CLE and the Grove Street Extension.

CLE ConnDOT Emergency Bridge Program

With the help of a structural engineer, I reviewed the Structure Layout for Design (SL/D) submission for Bridge No. 00618. This is an important phase of the design development. The roadway alignment, and structure type (welded plate girders) have been established but all other features of the bridge are being addressed for the first time. This particular project is very interesting because of interdisciplinary dependence.

The consultant proposed full height abutments on spread footings, one seated on rock, the other four feet above rock on a seam of gravel and boulders. The maximum bearing pressure of the bedrock is eight tons per square foot (TSF), the allowable bearing capacity of the gravel is five TSF with expected settlement of up to one inch. The structural engineer felt that it was unwise to construct a massive concrete structure on soil with rock that close. Rather than extend the abutment stem down four additional feet, we are recommending driving end-bearing piles to bedrock and raising the footing. Elimination or significant reduction in cofferdaming will result. Raising the footing has the undesirable effect of decreasing the waterway opening. However, the flow through this reach is supercritical and the reduction can be tolerated without increasing upstream elevations.

The consultant has recommended that the abutment and deck be constructed in two phases, allowing two-way traffic to be maintained. Although stage construction is not unusual it does require a construction joint; monolithic concrete placements are preferable. Based on the traffic volumes at this site, we are recommending that the construction joints be eliminated and alternating one-way construction be implemented.

# Greiner

We received a Type Study on Bridge No. 01594 in Kent this month. The designer has studied five alternatives:

- two span steel plate girders,
- two span steel box girders,
- two span precast concrete segmental box girders,
- single span steel plate girders,
- single span steel box girders.

Additional information has been requested from the consultant and our normal review has not yet begun; however, it appears certain that a two span bridge will be selected. The alternatives range in cost from \$1.52 million (two span steel plate girders) to \$2.10 million (single span steel box girders) but cost is not the only consideration. The vertical alignments developed with two span structures create less impact on adjacent properties. In part, these impacts are reflected in the cost but other intangible factors are also being considered.

I have had a number of meetings this month related to projects already in construction or about to begin. Generally, these meetings are to discuss changes in design. Depending on the circumstances, other parties represented are: property owners, contractors, ConnDOT and consultants.

The recent enactment of federal highway legislation has generated some additional activity this month. A number of projects that were previously identified as entirely State funded are being reassessed. ConnDOT wants to utilize all federal funds that may be available, I have three projects for which new federal aid is being pursued. Currently, I am researching the criteria to determine if these structures qualify.

## Grove Street Extension

Preparatory work on this project has begun. The work is a joint effort between the Tampa and Wallingford offices. I assist the project manager who is in Tampa. This month I attended the project initiation meeting in White Plains and also met with NYSDOT. I also met with the surveying subconsultant on several occasions to negotiate a scope of work and fee and later drafted the subconsultant agreement for approval by our management. The photogrammetric mapping is currently being prepared at a scale of 1"=40' and should be available in early May.

cc: Mr. Allen V. Herring, GES  
Dr. James S. Noel, TAMU

**Greiner**

Greiner Engineering Sciences  
P.O. Box 767  
20 Alexander Drive  
Wallingford, Connecticut 06492-2430  
(203) 265-6741

A Greiner Engineering, Inc. Company

To: Dr. Wesley P. James

May 29, 1987

From: Kevin Mahoney

Reference: Professional Internship, ENGR 684  
Report No. 9

My activities were split between the ConnDOT Emergency Bridge Program and Grove Street Extension again this month. The latter project has not developed commensurate with the original schedule.

CLE ConnDOT Emergency Bridge Program

This month I was involved in a series of construction related matters. I was also preparing two projects for advertising in June, as will be explained subsequently, both have been delayed.

Although the rehabilitation of Bridge No. 00761 is underway, my participation is still quite extensive. The as-bid construction cost is about \$4.6 million. However, soon after construction began it was realized that structural steel replacement and repairs had been underestimated. In May I represented Greiner at several meetings to address this problem. Unanticipated work has several undesirable impacts: additional expense to the State, lack of guidance in the plans and inadequate material stocks.

At a recent meeting it was decided that the designer should conduct an indepth field inspection and based on their observations prepare details for repair of stringers, floor beams, gussets and diagonal braces. Additionally, the designer is to develop deterioration-based criteria to be used by field inspection personnel to order specific repairs and replacements. I am currently preparing a change order with an estimated cost exceeding \$1 million. We have also been asked to develop plans and a schedule when a bridge lane could be closed to traffic for daytime construction operations. Presently, only night closures are allowed.

Bridge No. 00761 is immediately adjacent to an interchange and toll plaza. Traffic passes through the toll booths, merges and then crosses the bridge. Accommodating the toll operations and safe convergence of traffic to a reduced number of lanes is



## Greiner

an area of concern. This month I developed plans for various lane closures and met with affected units of ConnDOT to obtain their concurrence. The Divisions of Construction, Traffic and Tolls & Concessions have accepted the plans but the last has not agreed to a schedule when they may be implemented.

For most of May, preparing Bridge Nos. 00111 and 00785 for advertising was a priority assignment. That preparation included securing Federal funding for both projects. When the FHWA Division representative conducted an onboard review of these bridges both were rejected.

Federal HBR funds were used for a deck repair and parapet replacement rehabilitation of this structure last year. Consequently, the bridge was removed from the list of deficient structures and will remain ineligible for additional HBR funds until 1996. FHWA advised us to pursue 4R funds for this project. ConnDOT will pursue this matter through the Bureau of Administration.

Bridge No. 00785 is planned to be a superstructure replacement. The design consists of a concrete deck on adjacent, prestressed concrete, box beams. FHWA questioned the economy of this arrangement. There is no economic justification for the design. This concept was selected by ConnDOT's Manager of Bridge Design three years ago for the sake of expediency. At that time it was thought the work would be done entirely with State funds. A meeting will be held in the near future to identify options and select a course of action.

### Grove Street Extension

In May most of the work on this project was done by our survey and photogrammetry subconsultants. We did have enough information to develop a preliminary plan and profile for one of the alternatives. We are hard pressed to meet design criteria for a roadway that is to pass in a tunnel beneath a railroad and then at grade across the Bronx River flood plain. The project manager and I have discussed this with City and NYSDOT representatives at our May status meeting. A more accurate profile will be developed after all manuscripts are delivered and the required depth of structure is refined.

In the near future I will be heavily involved in developing geometrics for all alternatives, hydraulic modeling (HEC-2) and to a lesser extent traffic analysis.

cc: Mr. Allen V. Herring, GES  
Dr. James S. Noel, TAMU



Greiner Engineering Sciences  
20 Alexander Drive  
P.O. Box 767  
Wallingford, Connecticut 06492  
(203) 265-6741

A Greiner Engineering, Inc. Company

To: Dr. Wesley P. James

June 30, 1987

From: Kevin Mahoney

Reference: Professional Internship, ENGR 684  
Report No. 10

CLE ConnDOT Emergency Bridge Program

My involvement with this project was a reduced level compared to last month. However, my participation was greater than expected because of recently imposed schedules. In Report No. 9, I described FHWA's negative reaction to two projects scheduled for June advertising. Those projects are being redesigned; one will be advertised in August, the other in September.

One of the items that has been addressed in the redesign are the pin and hanger replacements at Bridge No. 00111. This design has been a continuing concern since October 1986 when the concept was developed. This month it was finally concluded that the jacking could not be accomplished from the deck. At a recent meeting with ConnDOT's Manager of Bridge Design, I was directed to evaluate three alternative replacement methods. Only one method appears viable, the other two permanently impact navigation clearance. Even if the Coast Guard would permit a clearance reduction, the application process would take months. The consultant has been directed to submit final plans and special provisions by July 1.

Last month I alluded to a change order being prepared for Bridge No. 00761. That change was made and the estimated additional cost is \$2.8 million, not the \$1 million I had expected. Even more additional work will be required at this bridge. This month I represented the CLE unit at several meetings to discuss implementation of design changes and to evaluate requests from Construction for more changes. The requested changes have been previously brought to the attention of the design consultant who contends that the work is not needed. Consequently, we are in the position of having to arbitrate these disagreements. I deal with the Construction staff assigned to this bridge almost daily.

Early this month at a meeting with ConnDOT representatives a

# Greiner

type selection was made for Bridge No. 01594 in Kent. The bridge will be a two span, steel box girder design. The consultant recommended precast, post-tensioned, concrete box girders, which are really not practical at this location. Box girders were chosen over plate girders, despite the higher cost, primarily due to aesthetics.

## Grove Street Extension

Several basic factors affecting the feasibility of this project were addressed this month. Various configurations have been previously developed with sufficient definition to ensure their viability from a horizontal perspective. Yet the question remained as to whether the numerous vertical constraints could be accommodated. The principal controls are the elevation of the Metro-North Railroad, under which the Extension must pass, and the flood plain of the Bronx River. Other less restrictive controls are elevations of existing utilities and roadways where grade separations or at-grade intersections are planned.

In summary of my efforts, all of the design criteria cannot be accommodated. However, that does not mean that the project is infeasible. At a meeting this month we presented our determination to the City of White Plains, they encouraged petitioning NYSDOT for a variance of the design criteria. Specifically, the City felt that a 14'-6" clearance under the railroad would be adequate as opposed to the 16'-6" dictated by the criteria.

Currently I am developing one of the anticipated two alternative horizontal alignments which includes a facility known as the Urban Interchange, which was originally developed by Greiner. There are currently no such facilities in the State of New York. Representatives from the City of White Plains, including the Mayor and Commissioner of Traffic are in Clearwater, Florida today to observe the operation and appearance of an existing, functional Urban Interchange.

cc: Mr. Allen V. Herring, GES  
Dr. James S. Noel, TAMU

**Greiner**

Greiner Engineering Sciences  
20 Alexander Drive  
P.O. Box 767  
Wallingford, Connecticut 06492  
(203) 265-6741

A Greiner Engineering, Inc. Company

To: Dr. Wesley P. James

July 31, 1987

From: Kevin Mahoney

Reference: Professional Internship, ENGR 684  
Report No. 11

CLE ConnDOT Emergency Bridge Program

The mandate from ConnDOT leadership to get projects advertised is still strong. We are requiring consultants to take any steps necessary to comply with established schedules; likewise we are having to accelerate our production rate. To date, the consultants have been very cooperative. To expedite design, I have been holding work sessions and reviews with the CEs at our offices. This month I also attended several meetings with F.H.W.A. and ConnDOT in July.

The design of Bridge No. 00111 was revised to change the pin and hanger replacement and bearing repair procedures. The F.H.W.A. conducted an onboard review and issued Design Approval. This project has been forwarded to ConnDOT and will be advertised beginning August 19.

I met with a group of property owners abutting Bridge No. 01308 in rural Washington. The group was understandably concerned about the impact of the project on their properties; a Report of Meeting is enclosed. I explained that the adopted concept was selected because of economy and that the existing bridge, though admittedly picturesque, was functionally obsolete and of indeterminable structural integrity. State statutes and current design standards require that a replacement structure provide for a minimum road width of 28 feet and rail systems to shield errant vehicles from obstructions.

The Manager of Bridge Design has reviewed the matter and he seems favorable to a project which will cost more but reduce the impact. That was a surprise reaction in view of current schedule concerns.

In Report No. 10 I indicated that ConnDOT had selected a two-span steel box girder structure type for Bridge No. 01594. This month that type selection was reversed. I represented the CLE at a meeting with F.H.W.A., ConnDOT Bridge Design and ConnDOT

## Greiner

Bridge Safety. Under pressure from F.H.W.A. on cost and Bridge Safety regarding inspection difficulties, the Manager of Bridge Design agreed to steel plate girders.

Late this month I was involved with contracting for a driller and analytical laboratory to collect and analyze soil samples at this bridge site. The samples will be tested for PCBs. If the testing program indicates the presence of PCBs above the 1 ppm threshold, the excavated material will require controlled disposal procedures. I have also been working with the Town Attorney to secure an easement for Fire Department access to the river.

As construction on Bridge No. 00761 progresses, items continue to surface requiring input from design. I processed another change order this month and at least one more will be required. The latest development is a redesign of the pin and hanger bracket. The four-lane deck is supported by three lines of half-thru plate girders; each girder is fracture critical. This 50 year old bridge has no expansion bearings, all thermal movements are accommodated by five pin and hanger assemblies in each line of girders. The bracket provided in the as-bid plans will reduce or eliminate expansion capability. A plan is being developed to achieve all the design requirements and will receive close review before being issued as a change order.

### Civil Group

The Grove Street Extension is my primary responsibility in this unit. The Tampa office has modeled existing and future traffic volumes; these data are being reviewed by NYSDOT. I prepared preliminary plans and profiles for NYSDOT to facilitate their review of the vertical clearance criteria waiver. That waiver has been granted which means the project is feasible, at least geometrically. I also prepared preliminary layouts of bikeways to be provided as part of the project. We had a progress meeting with the City of White Plains and NYSDOT late in July.

The lead management role of this project has change from Tampa to Wallingford this month. My internship supervisor will now be Principal-in-Charge. We have been working on schedules, subconsultant agreements and staff requirements.

I worked on a proposal for a multi-use land development project. The developer is hoping to construct a conference center, condominiums and various other structures on a parcel of beach-front land. The property includes an inland wetland, tidal wetland, dune system and other statutorily protected coastal resources. We met with the developer and DEP regulatory staff to

## Greiner

discuss the preliminary concept. As would be expected, the developer's notion of land use is far more intensive than DEP will allow. My draft of the proposal is being reviewed internally.

cc: Mr. Allen V. Herring, GES  
Dr. James S. Noel, TAMU

**Greiner**

Greiner, Inc.  
20 Alexander Drive  
Wallingford, Connecticut 06492-2430  
(203) 265-6741

---

To: Dr. Wesley P. James

August 31, 1987

From: Kevin Mahoney

Reference: Professional Internship, ENGR 684  
Report No. 12

CLE ConnDOT Emergency Bridge Program

This month was very busy as ConnDOT has decided to advance design of certain controversial projects that were not previously designed or for some reason require redesign.

Bridge No. 01308 is a project requiring complete redesign. In Report No. 11, I discussed my meeting with a group of abutting property owners who strongly objected to the construction plan and sequence. This month, I developed three alternative concepts and asked the consultant to prepare preliminary plans and cost estimates for each. That material was used for a meeting with the Manager of Bridge Design. The Manager chose the plan that calls for a temporary one-lane bridge over the construction area. This will eliminate the necessity to construct a detour over private property.

Bridge No. 01349 has been virtually dormant since I began my assignment. This bridge is a 110-year old truss bridge with a moveable span that pivots at one pier to allow boat passage. Several years ago, the State proposed replacing the bridge, the townspeople objected because of the structure's aesthetic and historical value. The State is statutorily prohibited from reconstructing any bridge with a roadway width of less than 28 feet. However, the State may rebuild the bridge at its current 19 foot width and transfer ownership to the Town. After months of legal maneuvering it appears that design will begin on that basis. A temporary bridge will be required to maintain traffic. I don't think anyone has considered river traffic for the temporary structure. A temporary moveable span bridge would be an extreme expense and the approaches are too short to develop vertical separation. This will be an interesting project.

I met with F.H.W.A. this month to review three bridges for which Design Approval was requested. The F.H.W.A. staff requested some minor modifications which were made before going out for advertising. Design Approval was received this month.

## Greiner

I met with a condominium association board this month in an attempt to secure a right of entry for Bridge No. 02601 scheduled to be advertised in September. Although the board was cordial and appreciated the background information provided they reacted unfavorably to the project.

The project is a bridge replacement in which the waterway opening of the structure is being widened. The approach channel is also being widened and side slopes stabilized with riprap. The board passed a resolution not to sign the right of entry and the project was removed from the advertising schedule.

Late this month I met with an attorney, retained by the association, to explain ConnDOT's position and intended action. The bridge is structurally deficient and must be replaced. The structure-induced backwater with the existing bridge is 2.3 feet for the 100-year event; a larger waterway opening must be provided. The only flexibility in the design is the approach channel. A hydraulic analysis is underway to evaluate a revised, nonconforming design of the channel. If excessive velocities or backwater are caused by the constriction and abrupt opening, the State will have no option but to condemn the land required. Advertising has been rescheduled for December.

Construction orders continue to be required for Bridge No. 00761. This month I was involved with structural steel repairs of a girder web, gusset plates and a pin and hanger bracket. The redecking and stringer replacement is approximately 50 percent complete.

Administratively, I reviewed one consultant invoice this month. The original invoice amount exceeded \$125,000 but was reduced by approximately \$23,000 because of an error. I also reviewed two Work Directives.

### Civil Group

The Grove Street Extension was relatively slow this month because of vacations and NYS DOT's pending review of traffic projections. I was involved in laying out base sheets and coordinating with Westchester County officials regarding access at the renovated County Center.

The State Historic Preservation Officer (SHPO) officially responded to the preliminary Cultural Resources Reconnaissance. The SHPO has an interest in three historical resources that will be impacted by the project. A meeting with NYS DOT and the SHPO is planned.

I prepared a revised subconsultant agreement for the surveyor this month. The subconsultant was concerned that the work description in the original description was too inclusive.



# Greiner

After discussing the project requirements with NYS DOT it was decided that a more defined, less inclusive scope was acceptable to us.

I have been working toward a September submittal of my Internship Report for Advisory Committee review. I hope to forward that draft in approximately 10 days. Shortly thereafter, I would like to have my final examination.

cc: Mr. Allen V. Herring, GES  
Dr. James S. Noel, TAMU

**APPENDIX C**  
**INTERNSHIP SUPERVISOR'S REPORT**

**Greiner**

Greiner, Inc.  
20 Alexander Drive  
Wallingford, Connecticut 06492-2430  
(203) 265-6741

---

September 15, 1987

Dr. Wesley P. James  
Chairman, Student's Advisory Committee  
Department of Civil Engineering  
Texas A&M University  
University Station, TX 77843-3133

Reference: Doctor of Engineering Internship  
of Mr. Kevin Mahoney

Dear Dr. James:

This letter is submitted as a summary of the performance of Mr. Mahoney during his practicum at Greiner, Inc. Mr. Mahoney served as doctoral intern in the Civil Engineering Department and the Consultant Liaison Engineer Group working on the ConnDOT Emergency Bridge Program from September 2, 1986 to the present date. The formal internship was a 12 month duration. Mr. Mahoney reported for the most part directly to Mr. Erwin Abonyi, Project Manager of the Consultant Liaison Engineer assignment. Part of his time was devoted to projects under my direction. I was his internship supervisor for the entire period.

Mr. Mahoney's performance as a practicing engineer has been excellent. Mr. Mahoney's internship objectives were:

- o Apply academic training and previous experience in civil engineering to the preparation of designs and studies.
- o Review and assess the quality of professional engineering services performed by other organizations.
- o Effectively coordinate the activities of peers and subordinates to meet schedule and budget constraints.
- o Develop the communication skills necessary to:
  - a. present the results of technical evaluations to parties with varying degrees of expertise.
  - b. establish and maintain a harmonious relationship with clients and coworkers whenever possible.

# Greiner

Dr. Wesley P. James  
September 15, 1987  
Page 2

- c. convince others of the benefits of modifying their position on an issue.
- o Participate in the project procurement process by assisting in the development of technical and price proposals.

Mr. Mahoney has successfully completed all assigned tasks and has contributed significantly to the progress of his assigned projects and to Greiner's continued growth. He has used good engineering judgement in his internship and his breadth of knowledge has contributed significantly to our Liaison operation.

I would particularly like to highlight Mr. Mahoney's strong dedication to maintaining project schedules and his overall attention to detail.

As the internship supervisor I compliment Mr. Mahoney on his efforts and recommend that the appropriate credits and approval of his practicum internship be granted.

Very truly yours,

GREINER, INC

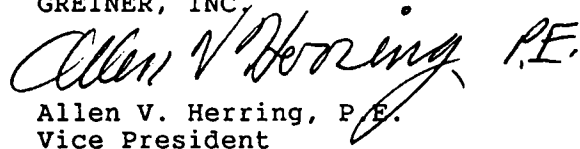
 P.E.

Allen V. Herring, P.E.  
Vice President

AVH/sak

cc: K. Mahoney  
E. Abonyi

2069K

VITA

Kevin Michael Mahoney received the B.S. with a major in Civil Engineering from the University of New Haven in 1977 and the M.S. in Civil Engineering from the University of South Florida in 1982. Mr. Mahoney also attended the University of Kentucky during 1983 and 1984.

Mr. Mahoney has been employed in private consulting since 1977 and has been on the staff of Greiner Engineering since 1979. Mr. Mahoney took an educational leave of absence in 1985 and 1986 to pursue the Doctor of Engineering degree at Texas A&M University. Mr. Mahoney's permanent mailing address is: 330 High Ridge Road, Fairfield, Connecticut, 06430.