

**ELUCIDATING THE FUNCTIONS OF SIALYLATION IN
*DROSOPHILA MELANOGASTER***

A Thesis

by

MINDY NICOLE CARNAHAN

Submitted to the Office of Graduate Studies of
Texas A&M University
in partial fulfillment of the requirements for the degree of
MASTER OF SCIENCE

August 2011

Major Subject: Genetics

Elucidating the Functions of Sialylation in *Drosophila melanogaster*

Copyright August 2011 Mindy Nicole Carnahan

**ELUCIDATING THE FUNCTIONS OF SIALYLATION IN
*DROSOPHILA MELANOGASTER***

A Thesis

by

MINDY NICOLE CARNAHAN

Submitted to the Office of Graduate Studies of
Texas A&M University
in partial fulfillment of the requirements for the degree of

MASTER OF SCIENCE

Approved by:

Chair of Committee, Vladislav Panin
Committee Members, Paul Hardin
James Wild
Mark Zoran

Chair of Genetics
Faculty, Craig Coates

August 2011

Major Subject: Genetics

ABSTRACT

Elucidating the Functions of Sialylation in

Drosophila melanogaster. (August 2011)

Mindy Nicole Carnahan, B.S., University of Illinois at Urbana-Champaign

Chair of Advisory Committee: Dr Vladislav M. Panin

Sialylation is an important carbohydrate modification of glycoconjugates, which introduces sialic acids (SA). The relatively large nine-carbon, negatively charged sugars are typically located at the termini of carbohydrate chains. SA's are often required for functionally important molecular and cellular interactions including virus-host interactions, tumor progression and malignancy, immune system development and function, and nervous system development and function. However, the study of sialylation in vertebrates, including man, encounters serious obstacles associated with the complexity of vertebrates' biology and limitations of available experimental approaches. *Drosophila* is a useful model system with many advantages including quick generation time, a large number of progeny, simplified glycosylation and neurophysiology, and ease of genetic manipulations. The primary focus of this thesis is on the functions of *Drosophila melanogaster* CMP sialic acid synthetase (DmCSAS) and sialyltransferase (DSiaT) in the central nervous system (CNS).

A combination of genetic, immunostaining, and neurobiology approaches were used to characterize the functions of DmCSAS and DSiaT in *Drosophila*. This investigation revealed the expression of DmCSAS and suggested that it plays an important role in a specialized and developmentally regulated process in the nervous system of *Drosophila*. Further experiments examined sub-cellular localization of DmCSAS revealing that this protein has a complex mostly Golgi-associated distribution within the cell *in vivo*. I discovered a novel link between *Drosophila* sialylation and circadian rhythm regulation. I also characterized the electrophysiological phenotypes of DmCSAS mutants and compared them to the corresponding defects associated with DSiaT mutations. My experiments also revealed that the relationship between DmCSAS and DSiaT are more complex than originally thought; these genes may have independent functions while also participating in the same pathway. Taken together, these results elucidate the sialylation pathway in *Drosophila* and shed more light on the role of sialylation in the nervous system. My experiments provide a unique evolutionary perspective on the sialylation pathway in animals and suggest that the neural function of SA in *Drosophila* can be conserved in vertebrates, including humans.

DEDICATION

To my family: Dad, Mom, Darin, Shane, and my wonderful husband Matt.

Thank you for always believing in me.

ACKNOWLEDGEMENTS

I would like to sincerely thank my advisor, Dr. Vlad Panin, for his wisdom, guidance, and support during my research at Texas A&M University. I will forever be grateful for the opportunities he has given me, and the generosity he has shown towards me not only as a student but also as an individual. Without him my success at Texas A&M University would not have been possible, and I cannot thank him enough for all that he has done.

I also want to thank my committee members, Dr. Paul Hardin, Dr. James Wild, and Dr. Mark Zoran, for their invaluable support, insight, and suggestions during my studies.

I want to thank all my friends and colleagues, both past and present, in the Panin lab: Elena, Dmitry, Dheeraj, Nao, Michiko, Apoorva, and Rafique. Their help and guidance has been immeasurable to my research and success at Texas A&M University.

I also have to thank my wonderful family for their unending support of my dreams. A special thank you to my mom for never letting me believe any differently, and thank you to my husband, Matt, who left his dreams behind so that I could follow mine.

NOMENCLATURE

CMP	cytidine monophosphate
CNS	central nervous system
CTP	cytidine triphosphate
DmCSAS	<i>Drosophila melanogaster</i> CMP sialic acid synthetase
DSiaT	<i>Drosophila melanogaster</i> sialyltransferase
Neu5Ac	N-acetylneuraminic acid
PP _i	pyrophosphate
Sia	sialic acid
UDP	uridine 5'-diphosphate
UDP-GlcNAc	UDP-N-acetylglucosamine

TABLE OF CONTENTS

	Page
ABSTRACT	iii
DEDICATION	v
ACKNOWLEDGEMENTS	vi
NOMENCLATURE.....	vii
TABLE OF CONTENTS.....	viii
LIST OF FIGURES	x
CHAPTER	
I INTRODUCTION	1
Biological importance of sialylation	4
Biosynthetic pathway of sialic acids.....	7
CMP sialic acid synthetase.....	15
Sialyltransferases	18
<i>Drosophila</i> as a model for studying sialylation.....	23
Thesis overview	25
II CHARACTERIZATION OF <i>DROSOPHILA</i> CMP SIALIC ACID SYNTHETASE EXPRESSION PATTERN	26
Introduction.....	26
Materials and methods	28
Results.....	35
Discussion	44

CHAPTER	Page
III	CHARACTERIZATION OF <i>DROSOPHILA</i> CMP SIALIC ACID SYNTHETASE AND SIALYLTRANSFERASE MUTANT PHENOTYPES 49
	Introduction..... 49
	Materials and methods 52
	Results..... 56
	Discussion 66
IV	CONCLUSION 69
	Expression pattern of DmCSAS 70
	Sub-cellular localization 70
	Circadian rhythm assay 72
	Electrophysiology 73
	Relationship between DmCSAS and DSiaT 74
	REFERENCES 77
	APPENDIX A 84
	APPENDIX B 86
	VITA 88

LIST OF FIGURES

FIGURE	Page
1 Structure of sialic acid	3
2 Comparison between the <i>de novo</i> biosynthetic pathways of sialylation in vertebrates, <i>Drosophila</i> , and bacteria	8
3 CMP Sialic Acid Synthetase (CSAS) reaction	12
4 Sialyltransferase (SiaT) reaction	14
5 Common structure of vertebrate sialyltransferase	20
6 DSiaT 3HA transfected <i>Drosophila</i> S2 cell.....	33
7 <i>Drosophila</i> CSAS expression pattern at embryonic stage 17 revealed by <i>in situ</i> hybridization	36
8 <i>Drosophila</i> CSAS expression pattern at third instar larval stage revealed by <i>in situ</i> hybridization	37
9 <i>Drosophila</i> CSAS expression pattern in the adult brain revealed by <i>in situ</i> hybridization	38
10 DmCSAS is localized in the Golgi in the CNS	40
11 DmCSAS is expressed in synapses in the larval CNS	41
12 DmCSAS and DSiaT co-localization in the CNS and Golgi of salivary glands.....	43
13 Comparison of DSiaT and DmCSAS expression in the larval brain revealed by <i>in situ</i> hybridization	45
14 DSiaT is localized to neuronal clock cells.....	57
15 DmCSAS mutants have a non-rhythmic phenotype	59

FIGURE		Page
16	DSiaT mutant flies have a shift in their circadian rhythms over time	60
17	DmCSAS mutants have defects in EJP amplitude in muscle 1 and muscle 6.....	63
18	Temperature sensitive paralysis of DmCSAS, DSiaT, and double mutant DSiaT;DmCSAS flies.....	65
19	Proposed relationship between DmCSAS and DSiaT	76
20	Representation of the strategy to create tagged DmCSAS	85
21	Schematic representation of the flip-out constructs.....	87

CHAPTER I

INTRODUCTION

In eukaryotic cells, one of the most common and complex forms of posttranslational protein modification is glycosylation (Koles et al., 2009). It is sometimes referred to as the “third language of life” with nucleic acids and proteins being the first and second languages respectively (Schauer, 2004). Over 1% of the genome in humans and other vertebrates is involved in tissue-specific, developmentally regulated glycosylation (Varki and Varki, 2007).

Sialylation is an important carbohydrate modification of glycoconjugates, which are proteins or lipids with sugars attached. The sugars of these glycoproteins and glycolipids are commonly referred to as carbohydrates or “glycans”. There are three major classes of protein glycosylation, *N*-linked, *O*-linked, and *C*-linked. *N*-linked glycosylation refers to glycans attached to proteins bonded to the amide nitrogen of an asparagine residue. *O*-linked glycosylation refers to glycans attached to proteins bonded to the hydroxyl group of a serine or threonine residue (Taylor and Drickamer, 2003), and *C*-linked glycosylation entails the C-1 atom of a mannose residue attaching to the C-2 atom of the indole ring of tryptophan (Varki, 1999).

Sialic acids, which are introduced by sialylation, are an unusual family of sugar residues. They are α -keto acids with a relatively large nine-carbon backbone, and they are negatively charged (Figure 1). They are also typically located at the termini of carbohydrate chains, and are subject to carry a variety of side group modifications (Angata and Varki, 2002; Koles et al., 2009). Sialic acids are often required for functionally important molecular and cellular interactions including virus-host interactions (Alexander and Dimock, 2002; Olofsson et al., 2005; Nilsson et al., 2008), tumor progression and malignancy (Hedlund et al., 2008), immune system development and function (Crocker et al., 2007), and nervous system development and function (Isaev et al., 2007; Rutishauser, 2008) (reviewed in Koles et al., 2009). Other interactions have been demonstrated, and it is likely, with further investigation, more will be found.

The study of sialylation in higher organisms, including man, has presented itself as rather complex, and genetic redundancy and limitations of genetic approaches complicate these investigations further. *Drosophila* is a unique model in which to study the evolutionarily conserved processes of sialylation due to its quick generation time, large number of progeny, simplified physiology, and well-studied genetics (Repnikova et al., 2010). However, the study of sialylation in protostomes is a relatively new field of study, and some protostome species appear to lack the processes necessary for sialylation (Angata and Varki, 2002). There have, however, been several steps in the sialylation pathway that have shown to be functional in *Drosophila*.

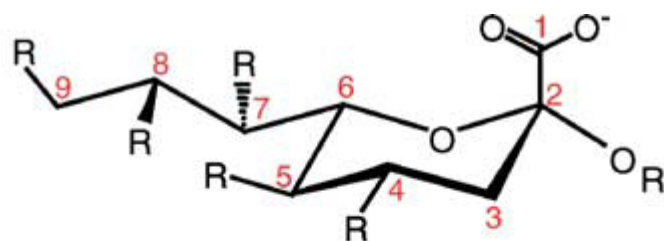

R2 = H in free Sia; alpha linkage to Gal(3/4/6), GalNAc(6),
GlcNAc(4/6) or Sia (8/9)

R4 = H or *O*-acetyl

R5 = Amino, *N*-acetyl, *N*-glycolyl or Hydroxyl

R7 = H, *O*-acetyl

R8 = H, *O*-acetyl, *O*-methyl, *O*-sulfate or Sia

R9 = OH, *O*-acetyl, *O*-lactyl, *O*-phosphate, *O*-sulfate or Sia

Figure 1. Structure of sialic acid.

Nine carbon structure of sialic acid. A negatively charged carboxylic acid residue is shown at carbon 1, the variety of linkages to the sugar chain is at carbon 2, several types of substitutions can be found at carbons 4, 5, 7, 8, and 9. Modified from (Varki and Varki, 2007).

These functional homologues of vertebrate enzymes include sialic acid phosphate synthetase (Kim et al., 2002), CMP-sialic acid synthetase (Viswanathan et al., 2006), and *Drosophila* sialyltransferase (Koles et al., 2004)(reviewed in (Repnikova et al., 2010). Although questions still remain concerning the biosynthetic machinery of the sialylation pathway in *Drosophila*, these insects are emerging as a useful and efficient model in the investigation of sialylation.

BIOLOGICAL IMPORTANCE OF SIALYLATION

Sialic acids are the most abundant terminal monosaccharides of glycoconjugates on the surface of eukaryotic cells, and they are critical in the development of life in higher animals (Schauer, 2004). The importance of these rather large, negatively charged sugars is quite apparent when the inhibition of the synthesis of sialic acids during early development in mice resulted in their lethality (Schwarzkopf et al., 2002).

The diversity of sialic acids contributes highly to their importance in life. Since sialic acids are located on terminal positions of glycans, this diversity has been utilized by a large variety of sialic acid-binding proteins, especially viral and bacterial pathogens. Influenza A and B viruses were one of the earliest discovered interactions with sialic acids. These viruses typically bind to α 2-3-linked sialic acids, which allow humans to be resistant to infection as the sialic

acids on the epithelium of upper airways in humans have α 2-6-linked sialic acids. Generally, these viruses must mutate in an intermediate host, such as the pig, in order bind to α 2-6-linked sialic acids, and thus achieve infection in a human host (Varki and Varki, 2007; Varki, 2008).

Sialic acids also play a critical role in the immune system. Selectins are a group of receptors expressed on leukocytes, platelets, and endothelium. These receptors play an important role in innate immunity, hemostasis, and restoration of blood flow to an injured ischemic tissue or organ (McEver, 2002; Ley, 2003; Varki and Varki, 2007). Sialic acids are an important component of most ligands for this group of selectin cell adhesion molecules. Other involvements in the immune system include: sialic acids being ligands for Siglecs (sialic acid binding Ig-like lectins), T cell dysfunction when there is a loss of immune-regulating Siglec molecules on T cells, activation of the immune system itself appears to be associated with cell surface sialic acids being downregulated, and *in vitro* studies have pointed to the loss of sialic acids as a contributing factor in the alteration of aspects to the immune response (Liang et al., 2006; Nan et al., 2007) (reviewed in Varki and Varki, 2007; Varki, 2008).

Tumor progression and malignancy has also been associated with sialic acids. Increased expression of sialic acids on cell surface glycans are often linked to a poor prognosis of many human malignancies (Varki and Varki, 2007). Further study on sialic acids and their changes in the body could allow researchers to explain some of the phenotypic changes in tumor cells by

examining changes in sialylation, using specific changes in sialylation as a diagnostic tool for certain types of tumors, and perhaps the ability to exploit changes in sialylation in the development of treatments to certain types of cancers (Taylor and Drickamer, 2003).

Furthermore, the biological importance of sialylation is apparent when examining its role in the development and function of the nervous system. The brain is the organ with the highest level of sialic acids in humans (Varki, 2008). A large developmental role is attributed to polysialic acid (PSA). PSA is primarily found on neural cell adhesion molecules (NCAM), and it has been documented in studies in mice to facilitate neural cell migration and neurite outgrowth (Angata et al., 2002). PSA has also been shown to be involved in motor neuron targeting (Rafuse and Landmesser, 2000) and axon guidance and fasciculation (Angata and Varki, 2002). Nervous system functioning and development has also recently been tied to sialyltransferases in *Drosophila* as well as the affect on the function of sodium voltage-gated channels (Repnikova et al., 2010). This key enzyme in the sialylation pathway and its importance to the nervous system of this species only further reiterates the evolutionary importance of sialylation in both protostomes and vertebrates.

BIOSYNTHETIC PATHWAY OF SIALIC ACIDS

Based on current publications, there are several enzymatic steps that comprise the *Drosophila* sialylation pathway (Figure 2). Vertebrate and bacterial sialic acid pathways are also compiled of several similar enzymatic steps (Koles et al., 2009). The vertebrate pathway, specific for the formation of the sialic acid *N*-acetylneuraminic acid (Neu5Ac), is synthesized by four reactions. The initiation of these reactions is the creation of *N*-acetylmannosamine (ManNAc) from UDP-*N*-acetylglucosamine (UDP-GlcNAc) and the bifunctional enzyme UDP-GlcNAc 2-epimerase/ManNAc kinase (GNE). GNE also catalyzes the second reaction as a multimer in the cytosol, which produces *N*-acetylmannosamine 6-phosphate (ManNAc-6-P) (Stasche et al., 1997; Weidemann et al., 2010). The fundamental role of GNE during development, and thus sialic acids in higher animals in general, was illustrated with the inactivation of GNE by gene targeting. This experiment caused early embryonic lethality in mice (Schwarzkopf et al., 2002).

Unlike the vertebrate sialylation pathway, the *Drosophila* genome does not appear to contain a GNE homologue (Kim et al., 2002), and only very low levels of the enzymes' activity was detected in Lepidopteran *Spodoptera frugiperda* (Sf9) cells (Effertz et al., 1999). ManNAc kinase activity in these cells, however, has been reported. This activity is theorized to come from an unrelated cytosolic kinase able to phosphorylate ManNAc such as GlcNAc kinase (Hinderlich et al., 2001; Koles et al., 2009).

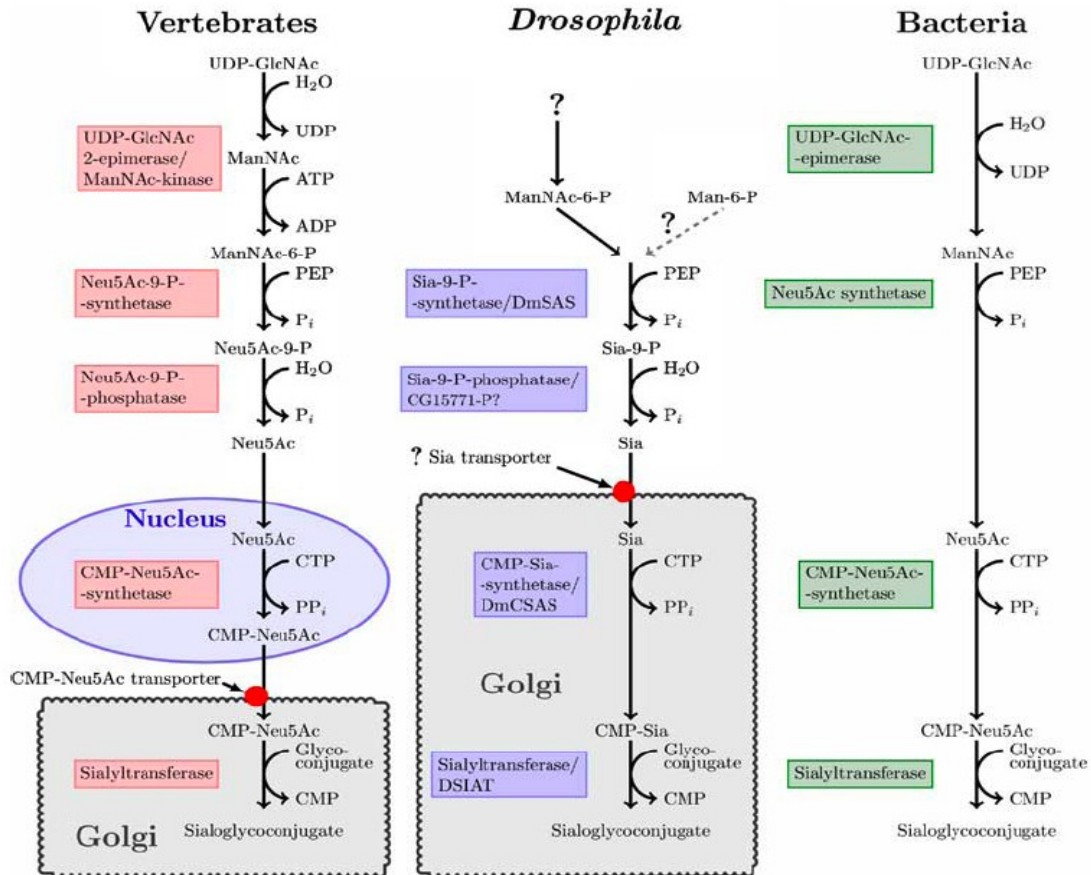

Figure 2. Comparison between the *de novo* biosynthetic pathways of sialylation in vertebrates, *Drosophila*, and bacteria. Modified from (Koles et al., 2009). Question marks indicate unknown and/or hypothetical steps or enzymes. The term “Sia” is used as a general term for any type of possible sialic acid, e.g. Neu5Ac or KDN.

The uncertainty surrounding the initiation of the sialylation pathway in *Drosophila* is an intriguing question, which has yet to be fully explained. However, *de novo* synthesis of sialylation in insects appears likely, and most other genes homologous to vertebrate genes in the pathway are present and functional (Koles et al., 2009).

One theory into the initiation of the sialylation pathway in *Drosophila* is through a deaminoneuraminic acid 2-keto-3-deoxy-D-glycero-D-galacto-nononic acid (KDN) biosynthesis. KDN biosynthesis has been shown to be predominantly responsible for sialylation in lower vertebrates and some pathogenic bacteria. KDN is found in almost all types of glycoconjugates, its residues are linked to almost all glycan structures in place of Neu5Ac, and it is biosynthesized *de novo* using mannose as a precursor sugar (Koles et al., 2009). This synthesis is analogous to the synthesis of Neu5Ac-9-P in the Neu5Ac pathway (Angata et al., 1999). KDN biosynthesis would avoid the need for UDP-GlcNAc 2-epimerase/ManNAc kinase, which is missing in *Drosophila*, and instead provide a means directly to the DmSAS level of the pathway. The reactions involved in KDN biosynthesis are also catalyzed by enzymes which can recognize not only KDN but often, and sometimes preferably, Neu5Ac as well (Inoue and Kitajima, 2006). The theory that *Drosophila* may synthesize KDN would help to partially explain the unknown initiation of the sialylation pathway in *Drosophila*; however, this theory is still under scrutiny as KDN has yet to be

detected in protostomes, and it would still leave the detected Neu5Ac modified glycans in *Drosophila* unexplained (Koles et al., 2009).

The next step of the vertebrate sialylation pathway involves Neu5Ac-9-P synthetase catalyzing the conversion of ManNAc-6-P to *N*-acetylneuraminic acid 9-phosphate (Neu5Ac-9-P) by condensation with PEP. A similar conversion in *Drosophila* is reported using the catalyst *Drosophila melanogaster* sialic acid synthetase (DmSAS). DmSAS has been confirmed by *in vitro* and cell culture assays, and its expression is present at every developmental stage examined. (Kim et al., 2002). Further investigation, however, is still needed to examine the phenotype of DmSAS mutants and the pattern of expression.

Following the synthesis of Neu5Ac-9-P in vertebrates (and/or possibly KDN-9-P in *Drosophila*) is the formation of sialic acid (Neu5Ac or Sia) by dephosphorylation of Neu5Ac-9-P catalyzed by *N*-acetylneuraminate-9-phosphate phosphatase (Maliekal et al., 2006). The CG15771 gene on the X chromosome encodes a homologue in *Drosophila*. Further information in this genes functional or phenotypic properties is not yet available (Koles et al., 2009).

The sialic acid generated then becomes a substrate for CMP sialic acid synthetase (CSAS) (Figure 3). This enzyme produces the sugar donor molecule, CMP-sialic acid, which is necessary for the synthesis of the final sialoglycoconjugate (Kean et al., 2004; Koles et al., 2009). A functional characterization of a *Drosophila melanogaster* CSAS (DmCSAS) gene has been

investigated using complementation of a mammalian cell line lacking CSAS activity (Viswanathan et al., 2006). The study, however, did not fully investigate DmCSAS *in vivo*. In particular, examination is still needed to investigate the *in vivo* pattern of expression, mutant phenotypes, and *in vivo* localization of the CSAS gene in *Drosophila*.

In vertebrates a sialic acid transporter would come into play after the formation of CMP-sialic acid to bring it from the cytosol to the Golgi for the final enzymatic step involving sialyltransferase. *Drosophila*, however, are unique in that DmCSAS has been shown, via cell culture, to localize to the Golgi (Viswanathan et al., 2006) making a sialic acid transporter unnecessary at this particular step. However, a transporter may be involved prior to the DmCSAS reaction to transport sialic acid into the Golgi to become CMP-sialic acid. Two genes encoding close homologues of a mammalian CMP-sialic acid transporter have been found in *Drosophila*. Products of these genes do not have the CMP-sialic acid transporter activity *in vitro*. However, whether or not these genes are

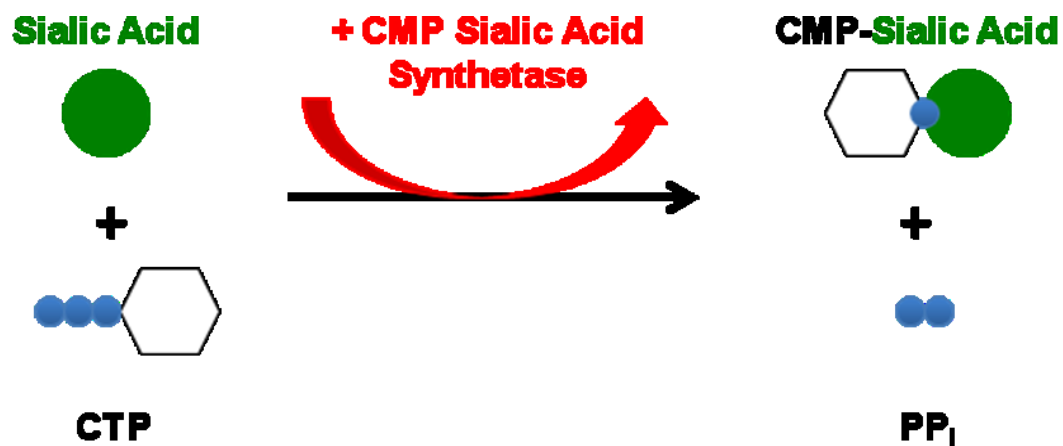

Figure 3. CMP Sialic Acid Synthetase (CSAS) reaction. CSAS catalyzes sialic acid and cytidine triphosphate (CTP) to create the donor sugar CMP-sialic acid.

actually involved in the transport of CMP-sialic acid *in vivo* is still unknown.

Several *Drosophila* genes encode predicted proteins with homology to vertebrate sialic acid transporters. The functions of these proteins have not yet been explored. (Koles et al., 2009).

Sialyltransferases make up the final enzymatic stage in the sialylation pathway. This last step involves transferring sialic acid from the donor sugar, CMP-sialic acid, to the acceptor glycoprotein or glycolipid using sialyltransferase as its catalyst (Figure 4). A functional *Drosophila* sialyltransferase has already been characterized (Koles et al., 2004), and its regulation of the nervous system in *Drosophila* has shown that sialylation has an important biological function in protostomes (Repnikova et al., 2010).

Overall, the biosynthetic pathways of sialic acids in vertebrates and *Drosophila* have many significant similarities. Several homologues of crucial enzymes in the sialylation pathway have been identified and examined in *Drosophila*, which suggests a common evolutionary origin between vertebrate and *Drosophila* sialylation pathways.

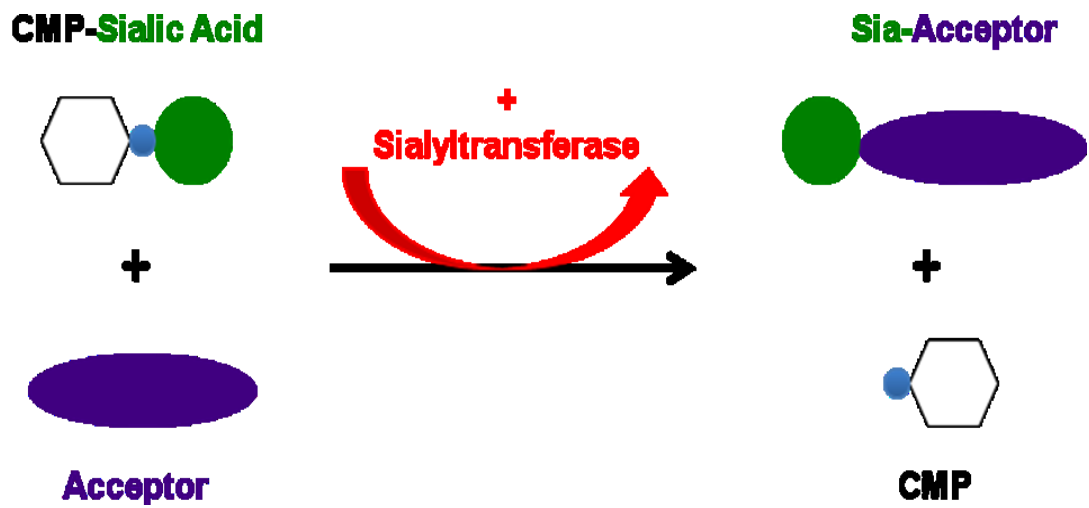

Figure 4. Sialyltransferase (SiaT) reaction. Sialic acid from CMP-sialic acid, generated by CSAS, is transferred to the acceptor glycoprotein or glycolipid by sialyltransferase.

CMP SIALIC ACID SYNTHETASE

CMP sialic acid synthetase (CSAS, aka CMAS and CSS) was first isolated and characterized in *Escherichia coli* K-235 cells (Comb et al., 1959; Comb et al., 1966). Later, it was described in other bacteria (Warren and Blacklow, 1962) and in mammalian hog submaxillary glands (Roseman, 1962; Kean and Roseman, 1966; Kean et al., 2004). This enzyme is recognized as being essential in the biosynthesis of sialic acids. CSAS catalyzes the synthesis of CMP sialic acid from CTP and sialic acid (see Figure 3). CMP sialic acid is the donor sugar needed in sialyltransferase reactions, and thus, the completion of the sialylation pathway. CMP sialic acids are unique in several ways. First, they are the only sugar nucleotides that contain one phosphate residue with the exception of CMP-3-deoxy-D-manno-octulosonate (KDO) (Ghalambor and Heath, 1966). Second, free sialic acids, versus the non-phosphorylated forms, are used as substrates (Comb et al., 1959). Finally, unlike all other eukaryotic nucleotide sugar synthetases, CSAS is localized in the nucleus in vertebrates. This nuclear localization has been well studied and reviewed (Kean et al., 2004; Munster-Kuhnel et al., 2004).

CSAS proteins have been found to contain five conserved motifs. These motifs are conserved from bacteria through humans, providing strong evidence for a common ancestral gene (Munster-Kuhnel et al., 2004). In vertebrates, CSAS contains an N-terminal catalytic domain and a C-terminal domain. The N-terminal domain is responsible for harboring the synthetase activity, and the

function of C-terminal domain remains unknown (Oschlies et al., 2009).

Drosophila CSAS (DmCSAS), in contrast to vertebrates, only has the catalytic domain. This structure is similar to that of bacterial CSAS enzymes (Viswanathan et al., 2006).

Unlike the twenty different vertebrate sialyltransferases, there is only one CSAS that has been identified in vertebrates. Recent bioinformatic studies have shown there to be only one CSAS gene present in *Drosophila* as well.

Drosophila CSAS and human CSAS were shown to have 35.5% homology (Viswanathan et al., 2006).

Drosophila CSAS has not been as well studied as its vertebrate counterparts. Previous studies in vertebrates have illustrated sialic acid and polysialic acid (PSA) to be present at high levels during specific stages of development (Roth et al., 1992). *Drosophila* sialyltransferase has also shown this same developmentally regulated expression (Koles et al., 2004) (reviewed in (Viswanathan et al., 2006)). DmCSAS was additionally shown to exhibit higher levels of expression during certain developmental periods in *Drosophila*, specifically during the 14-17 hour embryonic stages (Viswanathan et al., 2006). Furthermore, DmCSAS was observed primarily in the central nervous system (CNS) of *Drosophila* (Koles et al., 2009). This distinction is in contrast to human CSAS, which was shown to be ubiquitously expressed in human cells from multiple tissues (Lawrence et al., 2001).

Viswanathan et al. also found DmCSAS to be functional in a mutant mammalian cell line (LEC29.Lec32) lacking the endogenous activity of the enzyme. LEC29.Lec32 is a Chinese hamster ovary cell double mutant where the dominant mutation *lec 29* activates α (1, 3)-fucosyltransferase activity, and the *lec 32* mutation reduces CSAS activity by greater than 95%. It was shown that CMP-sialic acid, specifically CMP-Neu5Ac, levels increased in the hamster double mutant cell line transfected with DmCSAS both *in vitro* and *in vivo*. That investigation illustrated that the *Drosophila* gene encodes a protein with the ability to produce CMP-sialic acid in these mammalian mutant cells (Viswanathan et al., 2006).

Localization of DmCSAS was additionally examined in the same study. A mammalian cell line (COS-7 cells) and an insect cell line (*Spodoptera frugiperda* or Sf9 cells) were transfected with DmCSAS-GFP and immunostained with markers for different cellular compartments. These immunostainings revealed DmCSAS was not localized to the nucleus like its vertebrate counterparts, but instead localized to the Golgi in these cell lines. This difference in localization appears to be the first example of enzymes that are functionally equivalent to each other localizing to different compartments in different eukaryotes. This localization to the Golgi is logical, however, given that sialyltransferase is also located in the Golgi and a CMP-sialic acid transporter has not yet been identified in *Drosophila* (Viswanathan et al., 2006).

It is obvious that CMP sialic acid synthetase is a crucial element in the sialylation pathway. Its current evidence in *Drosophila* only reinforces the notion of sialylation in this insect and the real possibility of using *Drosophila* as a model in which to study the mechanisms involved in this evolutionarily conserved pathway. More investigation is still needed, however, on the specific *in vivo* expression and localization of CSAS in *Drosophila* itself versus mammalian or other insect cell lines, and phenotypes caused by CSAS mutations in *Drosophila*. The present study will investigate and address all of these issues.

SIALYLTRANSFERASES

Sialyltransferases comprise the final step of the sialylation pathway in vertebrates, bacteria, and *Drosophila*. This group of enzymes transfers sialic acid from CMP-sialic acid to the acceptor glycoprotein or glycolipid (see Figure 4). Sialyltransferases usually only synthesize one type of linkage between the acceptor substrates and sialic acid, and they also demonstrate explicit acceptor specificity. These enzymes often exhibit a regulated and specific pattern of sialylation, which can vary throughout different developmental stages (Harduin-Lepers et al., 2001; Koles et al., 2004).

To date, there have been twenty different sialyltransferases identified in mammals. All of these sialyltransferases are type II transmembrane proteins that

localize in the trans-Golgi, differ in their acceptor specificities, and synthesize different linkages (α 2-6, α 2-3, and α 2-8) (Koles et al., 2004).

These mammalian sialyltransferases have a common structure, which includes a short N-terminal cytoplasmic tail, a type II transmembrane anchor domain, a stem region of variable length (20-200 amino acids), and a conserved large C-terminal catalytic domain. The last two structures reside in the Golgi lumen (Figure 5). The catalytic domain of all vertebrate sialyltransferases is made up of four “sialylmotifs”. These motifs are where much of the enzymes’ activity takes place. They are suggested to be responsible for binding of the CMP-sialic acid, binding of the acceptor, and catalytic/enzymatic activity (Koles et al., 2004; Koles et al., 2009).

In *Drosophila*, a single gene was found which encodes an α 2-6-sialyltransferase similar to vertebrates called *Drosophila* sialyltransferase or DSiaT. This enzyme was found to have homology to the ST6Gal family of vertebrate sialyltransferases; specifically it is closest to the human subfamily hST6GalII. DSiaT was also found to encode a similar structure to that of vertebrate sialyltransferases including a type II transmembrane protein, N-terminal domain, stem region, and C-terminal catalytic domain (Koles et al., 2004).

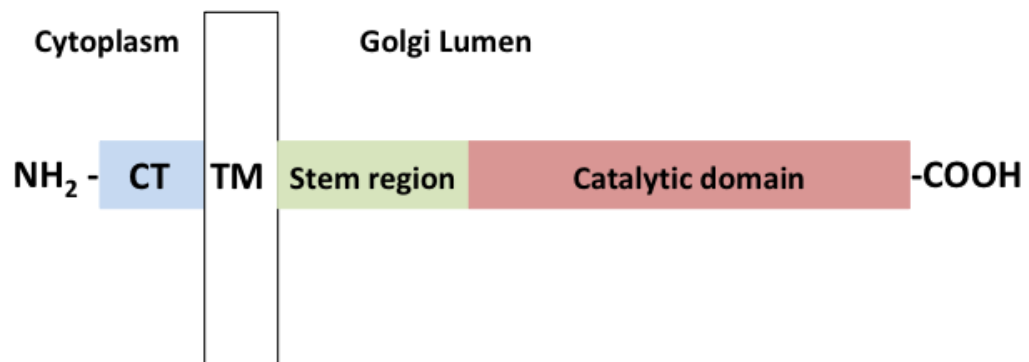

Figure 5. Common structure of vertebrate sialyltransferase. Sialyltransferases have a short N-terminal cytoplasmic tail (CT) in the cytoplasm, a transmembrane anchor domain (TM), a stem region of variable length located in the Golgi lumen, and a large C-terminal catalytic domain also located in the Golgi lumen.

These conserved elements between DSiaT and vertebrate sialyltransferases further represent the evolutionary importance of DSiaT. It indicates that the ST6Gal family of enzymes is the most evolutionarily ancient family of vertebrate sialyltransferases, which lead to the progression of other types of sialyltransferases in higher animals including man (Koles et al., 2009).

A recent investigation of DSiaT by Repnikova et al. in 2010 revealed DSiaT is expressed in a specific subset of CNS neurons throughout development in a spatial and temporally restricted and developmentally regulated process in the CNS. Like DSiaT, human ST6GalIII has also been shown to be expressed in a tissue-specific manner with elevated levels in the fetal and adult brain (Takashima et al., 2002; Krzewinski-Recchi et al., 2003) (reviewd in Repnikova et al., 2010). Currently, only ST6GalII function has been investigated, implicating this enzyme in immune system function and cancer (Hennet et al., 1998; Chiricolo et al., 2006; Hedlund et al., 2008). However, the function of ST6GalII, which is the sialyltransferase most closely related to DSiaT, is unknown. This makes DSiaT an even more exciting model to use in the study of sialylation. ST6GalIII is presumably one of the most evolutionary sialyltransferases discovered; yet its function in humans is unclear. The function of this sialyltransferase in *Drosophila*, however, is emerging and presenting the possibility that ST6GalIII is also involved in the regulation of the nervous system in humans (Repnikova et al., 2010).

In the same study by Repnikova et al., DSiaT loss-of-function mutant flies were generated and investigated. It was discovered that these mutations resulted in a decreased life span, locomotor abnormalities, temperature-sensitive paralysis, and defects of the neuromuscular junctions. The behavioral phenotypes were also shown to progress with age suggesting potential neurodegeneration is involved with deficiencies in *Drosophila* sialylation.

The investigation also revealed sodium voltage gated channels as a likely target in *Drosophila* sialylation. Electrophysiology experiments proposed DSiaT mutants to have defective action potentials or a defect in their neuronal excitability. These voltage-gated sodium channels play a major role in action potential initiation and propagation in most fly neurons (Loughney et al., 1989) (reviewed in Repnikova et al., 2010). Several experiments were conducted to investigate the effect of DSiaT on *para* (a gene which encodes a voltage-gated sodium channel) and vice versa. When investigating the temperature sensitive paralysis among DSiaT mutants and *para* mutants it was determined there was a synergistic phenotypic effect in the double mutant flies. DSiaT mutant flies were also more resistant to DDT exposure. DDT is an insecticide that interacts specifically with voltage-gated sodium channels. This particular experiment revealed an increase in mortality in wild-type flies exposed to DDT, however, DSiaT mutant flies were more likely to survive. The effect on excitatory junction potentials or EJP's was also measured after exposure to TTX. EJP's are seen as changes in membrane potential. Changes in the amplitude of evoked EJP's

can indicate differences in synaptic function and structure. TTX is a neurotoxin, which blocks sodium voltage-gated channels. This inhibition of the sodium voltage-gated channel (when exposed to TTX) allowed for DSiaT mutants to exhibit an increased amplitude of EJP's, and a slower decline in this amplitude over time in contrast to wildtype flies (Repnikova et al., 2010).

DROSOPHILA AS A MODEL FOR STUDYING SIALYLATION

Drosophila has, in the past, been a controversial model to use in the study of sialylation. Some investigations even failed to detect components of sialylation in insects, including sialylated glycans, a CMP-sialic acid donor, or sialyltransferase activity (Butters et al., 1981; Jarvis and Finn, 1996; Hollister et al., 1998; Hooker et al., 1999; Lopez et al., 1999; Tomiya et al., 2001). Much of this controversy has been resolved, however, as techniques and technologies have improved. More recent investigations have shown endogenous sialylation does occur in *Drosophila*. Mass spectrometry has confirmed the presence of sialic acids during embryonic stages and in the head of adult *Drosophila* (Aoki et al., 2007; Koles et al., 2007). The biological function of sialylation was also unknown until recently. A study by Repnikova et al. in 2010 revealed that sialylation is involved in regulating the nervous system in *Drosophila*. This investigation showed that sialylation has a specific, developmentally regulated function in the CNS of *Drosophila* (Repnikova et al., 2010).

The revelation of this specialized, developmentally regulated process of sialylation in *Drosophila* makes sense when examining the previous inconsistencies surrounding sialylation in insects. The expression of DSiaT and DmCSAS in early embryogenesis is not detectable; however, they do both become upregulated at later embryonic stages (Koles et al., 2004; Viswanathan et al., 2006). This late embryonic expression correlates with development of the CNS, which is where both DSiaT and DmCSAS are shown to be expressed (Koles et al., 2004; Koles et al., 2009).

As previously discussed, structural and functional similarities have also been shown between DSiaT and the family of ST6Gal vertebrate sialyltransferases. hSTGalI and hST6GalII are the two homologues to DSiaT in humans with hST6GalII being the closest in relation. The existence of this conserved and ancient function for sialylation only further reiterates the ability to use *Drosophila* as a model to study sialylation.

Furthermore, *Drosophila* represents a useful and unique model organism on a more fundamental level. The species has a quick generation time, a large number of progeny, simplified physiology, and well-studied genetics to name a few. Overall, the ability to use this species to further investigate and understand the fundamental processes of sialylation is clearly presenting itself to be one of fact rather than controversy.

THESIS OVERVIEW

The focus of my research is on the functions involved in the different components of the sialylation pathway in *Drosophila*, specifically DSiaT and DmCSAS. DmCSAS is the element in which most of my research was conducted and will be discussed; however, investigation of a novel DSiaT phenotype and phenotypes involving double mutant (DSiaT and DmCSAS) flies will also be characterized.

In Chapter II, I will focus on the pattern of expression of DmCSAS during different stages of development. *In situ* hybridization will show the *in vivo* expression of DmCSAS in the embryonic, larval, and adult brain. Immunostaining will reveal the *in vivo* sub-cellular localizations of DmCSAS in the larval brain, and the overlap of sub-cellular expression between DSiaT and DmCSAS in the larval CNS.

In Chapter III, I will describe the mutant phenotypes of DmCSAS and DSiaT mutant flies. Circadian rhythm assays on these mutant flies will reveal a novel phenotype associated with sialylation in *Drosophila*, and additional behavioral assays will show temperature sensitive paralysis in DmCSAS and double mutant flies. Furthermore, examination of EJPs using electrophysiology in DmCSAS mutant flies in comparison with DSiaT mutant flies will demonstrate abnormal excitability of the axonal membrane and/or neuromuscular junction (NMJ) transmission, and how these two genes potentially interact with each other.

CHAPTER II

CHARACTERIZATION OF *DROSOPHILA* CMP SIALIC ACID SYNTHETASE EXPRESSION PATTERN

INTRODUCTION

There are several enzymatic steps leading to the formation of the donor sugar CMP-sialic acid (see Figure 2). This sugar is a crucial element needed in the completion of the sialylation pathway in vertebrates, bacteria, and *Drosophila*. CMP sialic acid synthetase (CSAS) is the enzyme responsible for creating this donor sugar from CTP and sialic acid (see Figure 3).

Developmental expression of *Drosophila* CSAS (DmCSAS) mRNA has been examined using PCR amplifications of cDNA. These findings indicated DmCSAS to be present during late embryonic and adult stages at high levels. Lower levels of expression were also shown during the larval and pupae stages (Viswanathan et al., 2006). The late embryonic expression pattern was also investigated by use of *in situ* hybridization. This data revealed a specific pattern of expression in the CNS of stage 16 and 17 embryos (Koles et al., 2009).

Sub-cellular localization of recombinantly expressed DmCSAS has been investigated using a DmCSAS-GFP transfected mammalian cell line (COS-7 cells) and an insect cell line (Sf9 cells). These immunostainings revealed DmCSAS was localized in the Golgi rather than the nucleus like its vertebrate counterparts. Golgi localization for DmCSAS is due to its N-terminal sequence,

which is full of hydrophobic amino acids that function as a signal peptide. Localization to the Golgi appears to be an important component to DmCSAS. The enzyme was found to be inactive (no activity above background levels) when it was localized to the nucleus by substituting the N-terminal DmCSAS for the human N-terminal CSAS. Since a CMP-sialic acid transporter has not yet been identified in *Drosophila*, and sialyltransferase is also located in the Golgi, localization for DmCSAS in the Golgi is logical (Viswanathan et al., 2006).

Here, I reveal the pattern of DmCSAS expression throughout development using *in situ* hybridization. Late stage embryos are examined along with larval and adult brains. Previous studies only used mammalian or other insect cell lines in order to show DmCSAS localization. My experiments localize DmCSAS in the larval brain itself. I also reveal co-localization between DmCSAS and DSiaT. Together these findings give a better understanding of the complex biological role of the CSAS enzyme in *Drosophila*, and its evolutionary relationship to vertebrate counterpart.

MATERIALS AND METHODS

Drosophila strains and maintenance

Wildtype w^{1118} Canton-S were obtained from Josh Dubnau (Cold Spring Harbor Laboratory, Cold Spring Harbor, NY). UAS-C155-GAL4 and Syt-GFP lines were obtained from the Bloomington Stock Center (Indiana University). man II-GFP stock was obtained from Dr Bing Ye (University of Michigan). UAS-CSAS-Flag constructs were created in my laboratory (M. Nakamura). *Drosophila* stocks were maintained at room temperature (23°C), and cultured on standard cornmeal-malt-yeast medium.

In situ hybridization

In situ hybridization was carried out using standard protocol as described in (Lehmann and Tautz, 1994; Koles et al., 2004) on wildtype w^{1118} Canton-S embryos, larvae, and adult flies.

Embryos were collected on apple juice plates containing a yeast paste after approximately 18 hours. This time frame produced mainly late stage embryos. Embryos were then dechorinated by 50% bleach in distilled water for 2 minutes. After rinsing the embryos with distilled water, they were fixed in a 4% paraformaldehyde by vigorous shaking for 20 minutes. Once the fixation was complete, the embryos were rinsed in methanol several times. After the final methanol rinse, they were stored in methanol at -20°C until enough embryos had been collected for the *in situ* experiment to begin.

Larval brains were collected by selecting third instar larvae. The first half of the larvae containing the brain was inverted in cold Ringers solution. This was done to expose the brain for fixation and hybridization. It also allowed for less loss of brains during the fixation and experiment as they were still attached to the rest of the head. In addition, this method allowed me to examine the surrounding tissues of the larval CNS to see if any hybridization had taken place outside the larval CNS. After the inversion of the larval head, it was fixed in 4% paraformaldehyde for 20 minutes at room temperature on a nutator. Once fixation was complete, it was rinsed in cold Ringers, 50/50 Ringers and methanol, and methanol solutions, respectively. A final rinse in methanol was done, and the brains were then kept in methanol at -20°C until enough brains had been collected for the *in situ* experiment to begin. After the completion of the experiment, the larval brains were completely dissected from the rest of the larval tissues in 1x PBS solution.

Adult brains were collected from pharate adult and one day old adult flies. Brains were dissected completely in cold Ringers solution. The rest of the fixation protocol is the same as what was performed for larval brains.

Immunohistochemistry

Larval brains were collected and fixed the same way as described for *in situ* hybridization. All washes/incubations for the immunostaining were performed using PBT (1x PBS, 0.1% Tween-20) at room temperature on a

nutator unless otherwise noted. Stainings were performed in accordance to (Sullivan et al., 2008).

Once immunostaining was ready to begin, the brains were washed in PBT at four intervals of 15 minutes. After the washes were complete, the brains were blocked for 1 hour in a 5% solution of goat and/or donkey serum (chosen according to secondary antibody used). Incubation of the primary antibodies in 5% goat and/or donkey serum commenced overnight at 4°C on a nutator. The following day, the brains were washed again with PBT at four intervals of 15 minutes. After the washes, the brains were incubated with secondary antibodies in a 5% goat and/or donkey serum solution for 1 hour and 30 minutes. Once secondary antibodies were added, the tubes containing the brains were kept in foil to prevent any loss of staining due to laboratory and/or sun light.

After completion of the staining, larval brains were completely dissected from the rest of the larval tissues. They were then mounted with VectaShield (Vector Laboratories), and images were captured on a Zeiss Axioscope microscope using 20X, 40X, and 63X objectives.

Golgi localization

Golgi localization was performed using C155-GAL4; Mannosidase II-GFP (man II-GFP) crossed to UAS-CSAS-Flag. C155-GAL4 is a pan-neuronal driver, which drives expression in all post-mitotic neurons (Sink et al., 2001; Zhan et al., 2004). Man II-GFP is a medial and/or trans Golgi marker (Velasco et al., 1993),

and UAS-CSAS-Flag is a construct created to drive ectopic expression of the CSAS gene when a GAL 4 driver is used. In this cross, I used a pan-neuronal driver to show CSAS expression in the neuronal cells of the larval CNS. The purpose of this cross, and subsequent immunostaining, was to see if there were any overlaps in expression between CSAS and the man II-GFP Golgi marker. Any overlaps would show CSAS to be ectopically expressed in the Golgi of neuronal cells.

Primary antibody for CSAS was mouse anti-Flag (1:1000) (Invitrogen), and secondary antibody for CSAS was anti-mouse Cy3 (1:250) (Jackson Laboratories). Primary antibody for man II-GFP was rabbit anti-GFP (1:800) (Invitrogen), and secondary antibody for man II-GFP was Alexa anti-rabbit 488 (1:250) (Jackson Laboratories).

Stainings were performed as described in 'Immunohistochemistry' section.

Synaptic localization

Synaptic localization was performed using C155-GAL4; Syt-GFP crossed to UAS-CSAS-Flag. Synaptotagmin-GFP (Syt-GFP) is a GFP tagged synaptic marker (Zhang et al., 2002). C155-GAL4 and UAS-CSAS-Flag were described previously (see 'Golgi localization').

The purpose of this cross was to examine if there were any overlaps in expression between CSAS and the Syt-GFP synapse marker. Any overlaps of

expression would show CSAS to be ectopically expressed in the synapses of the larval CNS neuronal cells.

Primary antibody for CSAS was mouse anti-Flag (1:1000) (Invitrogen), and secondary antibody for CSAS was anti-mouse Cy3 (1:250) (Jackson Laboratories). No primary or secondary antibody was needed for Syt-GFP as the GFP present in the cross was strong enough to show expression of the synapses in the larval CNS.

Stainings were performed as described in 'Immunohistochemistry' section.

DmCSAS and DSiaT co-localization

Co-localization between DmCSAS and DSiaT was performed by immunostaining larval brains from C155-GAL4 crossed to UAS-CSAS-Flag;DSiaT 3HA line of flies for figure 10, A and B. UAS-CSAS-Flag;DSiaT HA flies were used for figure 10, C-E.

DSiaT 3HA is an expression construct I created by standard molecular cloning. It is a pUAST construct with an approximately 1450bp DSiaT gene cloned to three HA tags. The three HA tags allow for more precise and clearer immunostainings of DSiaT. The construct was confirmed active by transfecting a pmk33 version of the same construct into *Drosophila* S2 cells and staining them for HA (Figure 6).

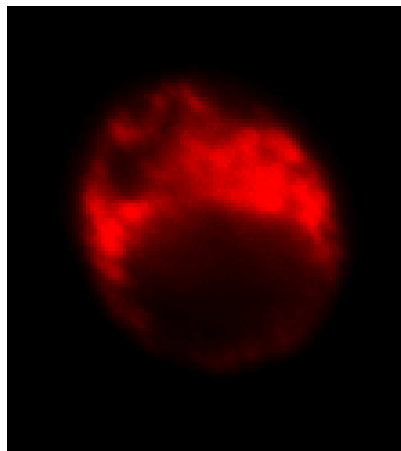

Figure 6. DSiaT 3HA transfected *Drosophila* S2 cell. Staining shows DSiaT 3HA to be active in cell culture when transfected into stable S2 cells. Primary antibody was rat anti-HA (1:800) (Roche). Secondary antibody was anti-rat Cy3 (1:250) (Jackson Laboratories).

Once completed, this recombinant DNA was sent for embryo injections to GenetiVision Inc. After the embryos were received back in my lab, standard selection protocol was followed for transgenic flies to produce lines containing the transgene on all chromosomes except chromosome 4. The transgenic flies used for the cross in the staining contained the transgene on chromosome 3.

The purpose of this staining is to understand the relationship between DSiaT and DmCSAS; where their expression patterns overlap and where they do not, and whether there are any independent functions between the two enzymes.

Primary antibody for CSAS was mouse anti-Flag (1:1000) (Invitrogen), and secondary antibody for CSAS was Alexa anti-mouse 488 (1:250) (Jackson Laboratories). Primary antibody for DSiaT was rat anti-HA (1:1000) (Roche), and secondary antibody for DSiaT was anti-rat Cy3 (1:250) (Jackson Laboratories).

Stainings were performed as described in 'Immunohistochemistry' section.

RESULTS

To understand the function of DmCSAS during the development of *Drosophila*, I analyzed the expression pattern of DmCSAS throughout embryonic, larval, and adult stages using *in situ* hybridization focused on the CNS. This experiment allowed me to analyze the distribution of the expression of DmCSAS mRNA *in vivo* (Figures 7, 8, and 9).

A CSAS antibody for endogenous expression could not be accomplished in order to compliment the results achieved by *in situ* hybridization. A bacmid construct was instead constructed in order to complete this, and results of this construct are ongoing (see Appendix A).

Patterns of expression using *in situ* hybridization were also examined in other tissues, specifically *Drosophila* adult ovaries and testes and tissues surrounding the larval CNS. No expression was found outside of the CNS (data not shown).

A double staining *in situ* hybridization and FISH for DmCSAS and DSiaT was also attempted to show co-localization of the two enzymes. The results of these experiments were inconclusive because of technical obstacles that were encountered when I used these challenging protocols.

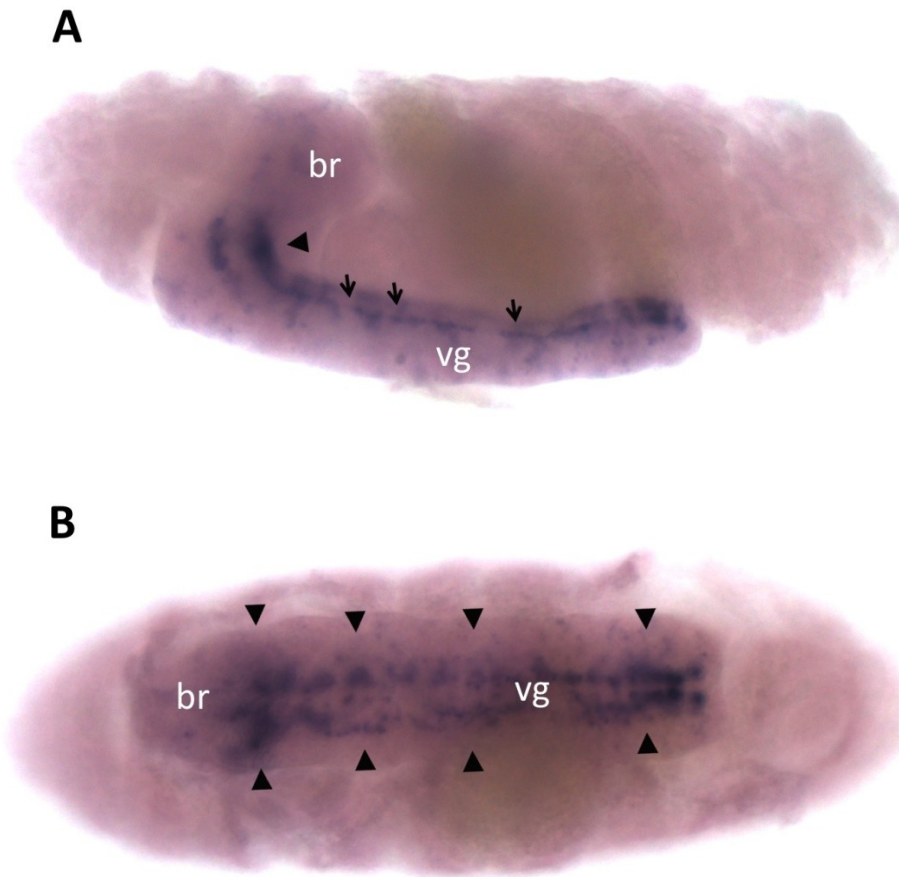

Figure 7. *Drosophila* CSAS expression pattern at embryonic stage 17 revealed by *in situ* hybridization.

A, Stage 17, lateral view. Expression is seen in the ventral ganglion (vg) and embryonic brain (br) regions of the CNS. Expression can be seen in the brain area (arrowhead) all the way through to the axonal longitudinal connective regions (arrows).

B, Stage 17, ventral view. Many cells in the brain and ventral ganglion show expression of CSAS (arrowheads).

All images were obtained using 20X objective magnification.

In all images anterior is to the left.

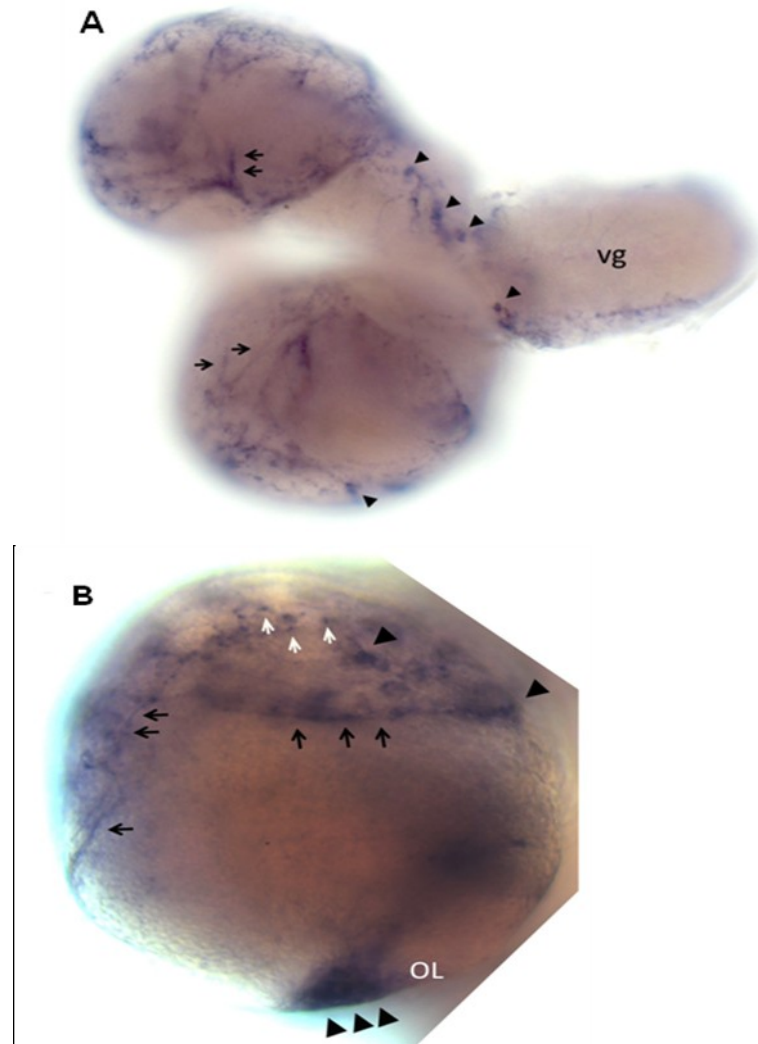

Figure 8. *Drosophila* CSAS expression pattern at third instar larval stage revealed by *in situ* hybridization.

A, CSAS expression in the brain hemispheres and ventral ganglion (vg). Expression is seen in some presumptive neurons (arrowheads) and neurites (arrows). Image was obtained using 20X objective magnification.

B, Magnified image of a brain hemisphere. CSAS expression is seen in the presumptive synapses (white arrows), neurons (arrowheads), and neurites (black arrows). High expression is also seen in the optic lobe (OL). Image was obtained using 40X objective magnification.

In all images, anterior is to the left.

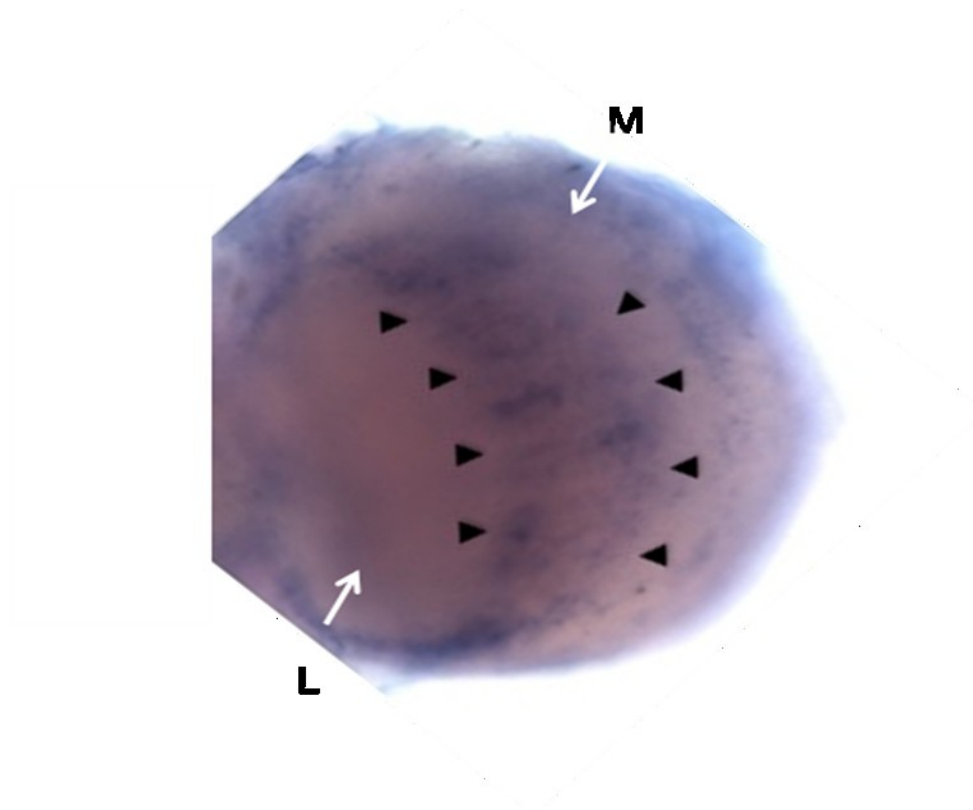

Figure 9. *Drosophila* CSAS expression pattern in the adult brain revealed by *in situ* hybridization.

Expression of DmCSAS can be seen throughout the optic lobe (arrowheads) in regions separating the medulla (M) and lobula (L) (white arrows).

Image was obtained using 20X objective magnification.

Frontal view, dorsal side up.

The sub-cellular localization of DmCSAS has never been investigated *in vivo*. Thus, I ectopically expressed UAS-CSAS-Flag in flies and performed a double staining with CSAS and a Golgi marker (man II-GFP) (Velasco et al., 1993). A neuronal driver, C155-GAL4, was used to drive the ectopic expression of CSAS in neurons. The double staining shows there is expression of DmCSAS in the Golgi of neuronal cells *in vivo* (Figure 10).

In situ hybridization and immunostainings suggested that the DmCSAS transcript and protein could be localized to synaptic structures. I decided to examine this further by performing a double staining using UAS-CSAS-Flag and a synaptic marker (Syt-GFP) (Zhang et al., 2002). The C155-GAL4 neuronal driver was again used to drive the expression of CSAS. The double staining revealed CSAS to be expressed in synapses in both the ventral ganglion (Figure 11, A-C) and the brain hemispheres (Figure 11, D-F) in the larval CNS.

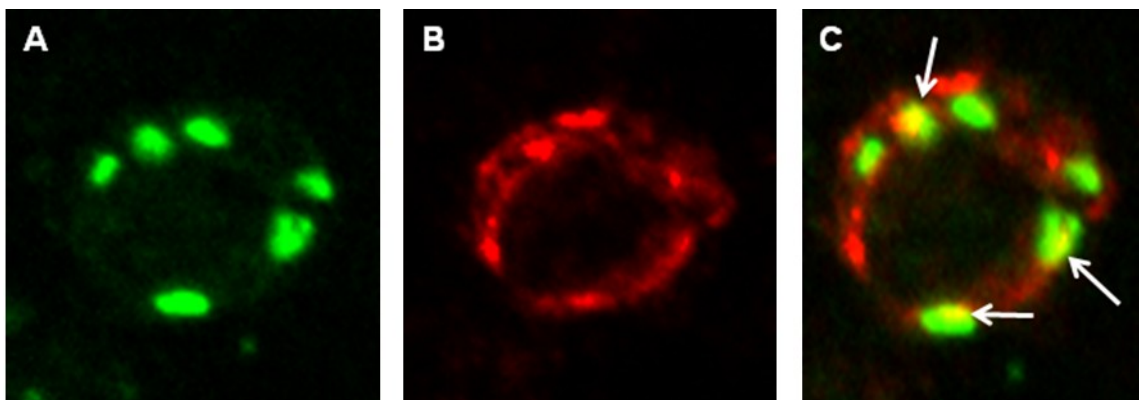

Figure 10. DmCSAS is localized in the Golgi in the CNS.

A, Staining showing just Golgi localizations (green) in a neuronal cell.

B, Staining showing just DmCSAS expression (red) in a neuronal cell.

C, Double staining of DmCSAS and the Golgi marker. White arrows indicate co-localization between DmCSAS and the Golgi marker (yellow).

All images were obtained using 63X objective magnification.

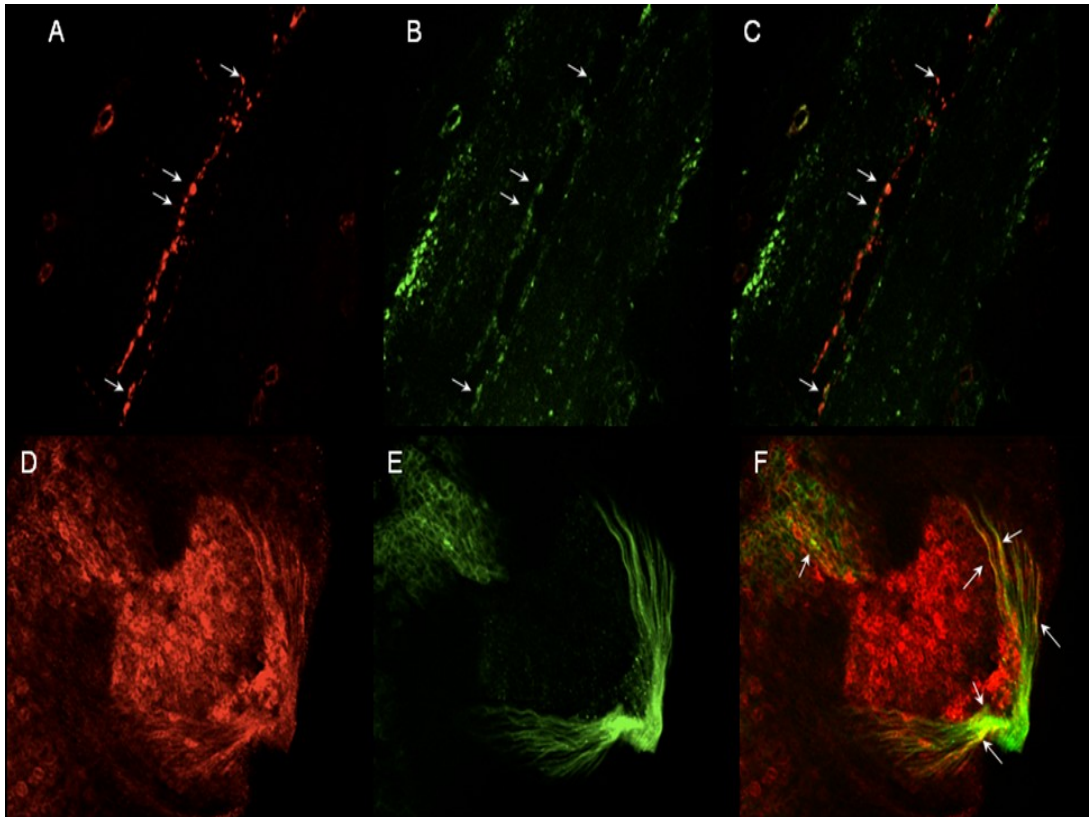

Figure 11. DmCSAS is expressed in synapses in the larval CNS. **A-C**, Expression of DmCSAS and synapses in the ventral ganglion. Co-localization between DmCSAS and synapses can be seen in image C (white arrows). Image obtained using 63X objective magnification. **D-F**, Co-localization of DmCSAS and Syt-GFP synaptic marker in the brain hemisphere. Co-localization between DmCSAS and Syt-GFP can be seen in image F (white arrows). Image obtained using 40X objective magnification. In all images red staining is DmCSAS expression, green staining is Syt-GFP, and yellow staining indicates co-localization between the two.

Since DmCSAS and DSiaT are both involved in the sialylation pathway of *Drosophila*, and the proposed biochemical pathway (see Figure 2) shows their interaction in a linear fashion, it was hypothesized that there could be overlap in their sub-cellular expression in the larval CNS. Co-localization between DmCSAS and DSiaT was investigated with immunostaining. UAS-CSAS-Flag and HA tagged DSiaT flies were used along with the C155-GAL4 neuronal driver. These stainings revealed there was some co-localization between the two proteins in neuronal cells of the CNS (Figure 12, A and B) and complete co-localization in the Golgi of larval salivary glands (Figure 12, C-E).

The staining also revealed some neuronal cells lacked either DmCSAS or the DSiaT protein all together (Figure 12, A). That is, certain neuronal cells only contained DSiaT or only contained DmCSAS but not both proteins. This was an interesting discovery considering the same pan-neuronal driver was used to ectopically express both proteins. The lack of expression of DSiaT or DmCSAS in some of these cells suggests the post-transcriptional regulation of the DmCSAS and DSiaT genes.

The ectopic expression observed in the salivary gland cells represents the expression of DmCSAS and DSiaT in the Golgi of these cells. It can be concluded the expression observed is in the Golgi due to the expression of DSiaT. DSiaT has already been investigated and found to localize in the Golgi (Koles et al., 2004); therefore, it can be concluded the complete co-localization seen between DmCSAS and DSiaT is in the Golgi of these salivary gland cells.

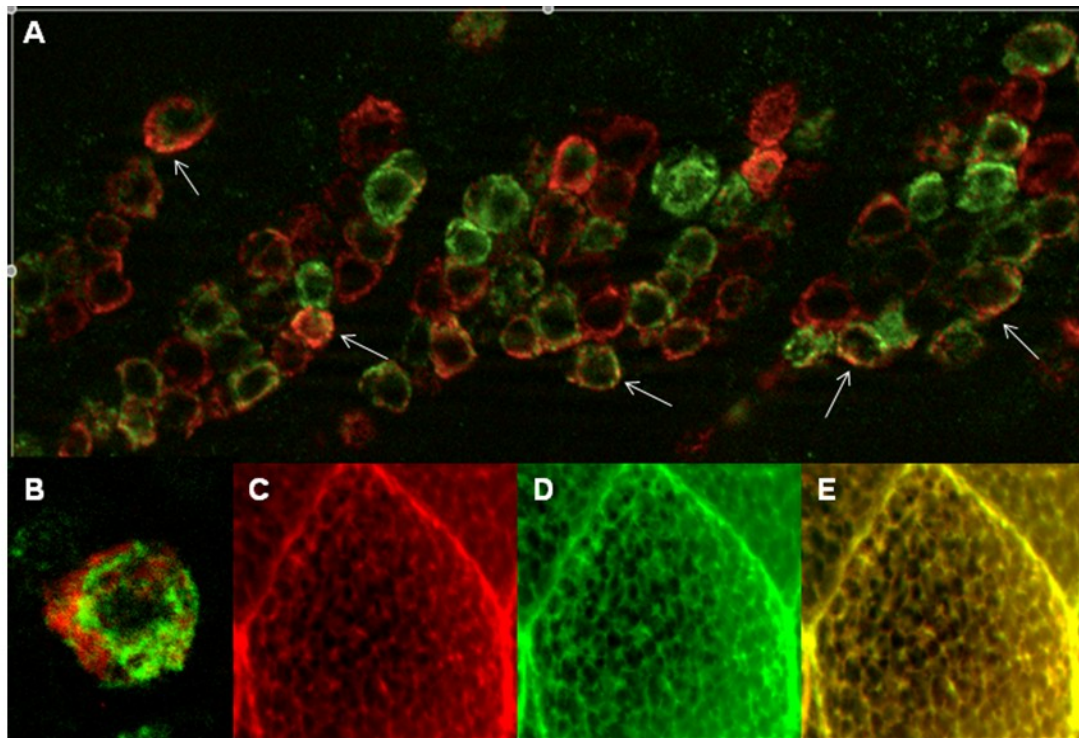

Figure 12. DmCSAS and DSiaT co-localization in the CNS and Golgi of salivary glands.

A, View of several neuronal cells in the larval CNS. Some cells reveal co-localization between DmCSAS and DSiaT (white arrows) while other cells do not.

B, Magnified view of a CNS neuronal cell showing non-overlapping localization between DmCSAS and DSiaT.

C-E, Localization of DSiaT (red), DmCSAS (green), and the complete co-localization between the two proteins (yellow) in the Golgi of a salivary gland cell.

In all images red staining is DSiaT expression, green staining is DmCSAS expression, and yellow staining indicates co-localization between the two proteins.

All images were obtained using 63X objective magnification

DISCUSSION

In this chapter, I have attempted to answer some fundamental questions about the function of sialylation pathway genes in *Drosophila*, including questions concerning the expression and the sub-cellular localization of DmCSAS. Specifically, I have addressed the following questions: What is the pattern of DmCSAS expression *in vivo*? Where is DmCSAS localized in the cell? Do DmCSAS and DSiaT have similar or overlapping expressions? The answers I have uncovered give a greater understanding of the biological function and importance of sialylation in *Drosophila*, which will help to further understand its evolutionary role in humans.

The expression of DmCSAS, revealed by my *in situ* hybridization experiments, indicated that DmCSAS is expressed throughout development of the CNS, starting at late embryonic stages (at approximately stage 16). Therefore, DmCSAS, like DSiaT, is involved in a developmentally regulated, tissue specific process. The CNS specific expression of DmCSAS also demonstrates that its function is mainly involved in the regulation of the nervous system. When examining the expression pattern of DmCSAS at larval stages, I found that it appears to have a more complex expression when compared to DSiaT (Figure 13, A and B). Here, the pattern of DmCSAS expression is seen not only in presumed neuronal cells, but presumed synapses and neurites as well. Overall, DmCSAS expression is detected in a broader pattern as compared to the pattern of DSiaT in the larval brain of the same stage.

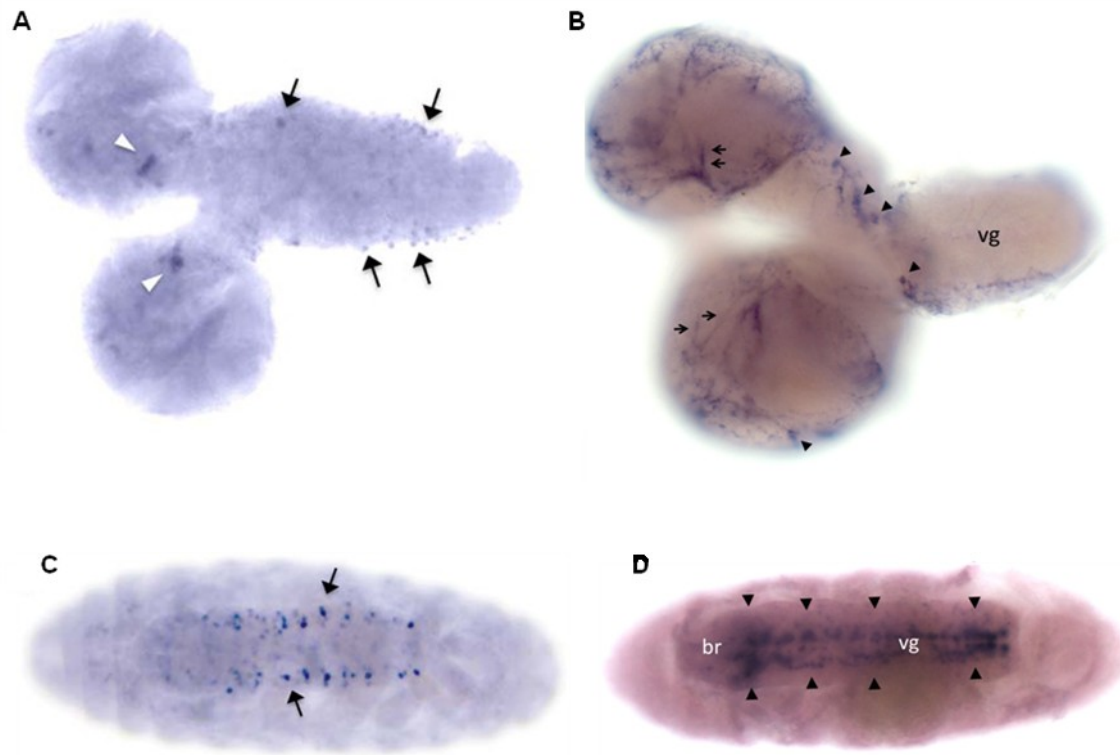

Figure 13. Comparison of DSiaT and DmCSAS expression in the larval brain revealed by *in situ* hybridization.

A, DSiaT expression pattern in third instar larvae. Expression is detected in cell bodies (arrows) and in the larval brain hemispheres (white arrowheads).

Modified from (Koles et al., 2009).

B, DmCSAS expression pattern in third instar larvae. For additional information see figure 8A.

C, DSiaT expression pattern in stage 17 embryo. Expression is detected in cell bodies (arrows). Modified from (Koles et al., 2009).

D, DmCSAS expression pattern in stage 17 embryo. For additional information see figure 7B.

All images anterior is to the left.

The comparison of the embryonic patterns of DmCSAS and DSiaT is also one of interest (Figure 13, C and D). DSiaT and DmCSAS both have overlapping and non-overlapping territories of expression within the CNS. Curiously, there is a high level of DmCSAS expression observed in the brain region (br) of the stage 17 embryo (Figure 13, D), while no significant DSiaT expression is detected in the same region (Figure 13, C).

I also investigated the sub-cellular localization of the DmCSAS protein *in vivo* using a UAS-GAL4 ectopic expression approach and FLAG-tagged DmCSAS protein. Applying Golgi and synaptic markers, I revealed that DmCSAS localizes to the Golgi compartment of neurons, while also being transported to the regions of synaptic connections. These results demonstrated for the first time that DmCSAS is a Golgi protein *in vivo*, and is also present in synapses. The immunostaining, however, showed that DmCSAS could also localize outside of the Golgi compartment. Further investigation of endogenously expressed DmCSAS is needed in order to confirm the sub-cellular locations of DmCSAS in the cell. This approach is ongoing and I have created a construct in which to study the endogenous expression of DmCSAS (see Appendix A). It has been demonstrated that Golgi localization is important for the enzymatic activity of DmCSAS (Viswanathan et al., 2006); thus, the localizations seen outside the Golgi could represent enzymatically inactive forms of CSAS.

The expression of DmCSAS in synapses through immunostaining also reiterates the findings revealed by the *in situ* hybridization experiments (see

Figure 8, B). The *in situ* experiments detected DmCSAS transcript present in what was presumed to be synaptic structures in the brain hemispheres. This result is consistent with my finding that the DmCSAS protein can be found in the region of synaptic connections, which was confirmed by the double staining with a synaptic marker. This double staining also revealed some co-localization between synapses and DmCSAS in the ventral ganglion (see figure 11, A-C). My *in situ* experiments did not detect DmCSAS transcript at synapses in this region, suggesting that the DmCSAS protein can be transported to synapses upon its translation.

Finally, I examined the co-localization between DmCSAS and DSiaT in the CNS and the Golgi of salivary glands. My *in situ* hybridization experiments revealed that DmCSAS and DSiaT have similar yet unique patterns of expression within the CNS (see Figure 13). Interestingly, double immunostainings indicated the sub-cellular patterns of DmCSAS and DSiaT protein distributions have similar relations: they co-localize in some, but not all, neuronal cells. However, complete co-localization was observed in the Golgi of salivary gland cells. The staining also revealed some neuronal cells only contained DSiaT or only contained DmCSAS but not both proteins (see Figure 12, A). Considering the same pan-neuronal driver was used to ectopically express both proteins, the lack of expression of DSiaT or DmCSAS in some of these cells is most likely explained by the post-transcriptional regulation of DmCSAS and DSiaT expression.

Together, my findings illustrate the unique and complex mechanisms surrounding the *Drosophila* sialylation pathway including the complex nature of the regulation of sub-cellular localization of DmCSAS. Due to the discoveries revealed in this chapter, I can reasonably conclude that the function of DmCSAS, like DSiaT, is a developmentally regulated, tissue specific process, which is most likely involved in regulating the nervous system, and the sub-cellular localization of DmCSAS is complex.

CHAPTER III

CHARACTERIZATION OF *DROSOPHILA* CMP SIALIC ACID SYNTHETASE AND SIALYLTRANSFERASE MUTANT PHENOTYPES

INTRODUCTION

Sialic acids, and the biosynthesis of sialic acids, play a major role in many of the human body's biological functions and diseases. These large, hydrophilic sugars are important from the perspectives of several fields of human biology including: neurology, oncology, hematology, nephrology, immunology and infectious disease, fertility, endocrinology, dermatology, and gastroenterology to name a few (Varki, 2008).

Examples on how a sialyltransferase and sialic acid can affect humans specifically include cases of cancer malignancies in association with a sialyltransferase and pathogen host interactions with sialic acid. As previously discussed, *Drosophila* sialyltransferase (DSiaT) is closely related to the human ST6Gal family of sialyltransferases. The overexpression of hST6GalII sialyltransferase has been shown to have a correlation with the invasive behavior of cancer cells (Chiricolo et al., 2006). *Neisseria gonorrhoea* and *Neisseria meningitides* group A are two examples of pathogens that use the host CMP-sialic acid to decorate their surface with sialylation. These pathogens are

responsible for two major diseases, gonorrhoea and meningitis respectively (Varki, 2008).

From these few examples, and the countless ways sialic acids can affect the human body, it is evident that understanding sialylation and the characterization of functions and phenotypes of the genes involved is essential to further understanding human biology and disease. Research, however, is difficult when using mammalian species. The complexity of their nervous system, functional redundancy, and intricate regulation of the sialylation pathway do not make them an ideal model system (Repnikova et al., 2010). My lab has developed efficient ways to study sialylation in *Drosophila*. Here, I have classified some of the *Drosophila* mutant phenotypes involved in two major components of the sialylation pathway: CMP sialic acid synthetase (DmCSAS) and sialyltransferase (DSiaT).

Circadian rhythms are an essential mechanism used by living cells to adapt to the daily and seasonal fluctuation in light and temperature (Ben-Shlomo and Kyriacou, 2002). These internal clocks are found in animals, plants, fungi, and some prokaryotes (Hardin, 2005). *Drosophila* displays a circadian rhythm in activity, where activity increases during pre-dawn and pre-dusk time periods, and these rhythms in activity persist under constant conditions (Zhang et al., 2010). In *Drosophila*, circadian clocks have been shown to affect adult emergence (eclosion), locomotor activity, and olfactory physiology (Hardin, 2005). In mice, it has been found that genetic deletions of polysialic acid (PSA)

and the neural cell adhesion molecules (NCAM) that carry them results in impairment of their circadian rhythms. Specifically, it was found that after entrainment of an LD cycle (12 hours of light followed by 12 hours of darkness), PSA and NCAM were necessary for the stable and free running circadian activity during DD (complete darkness) (Shen et al., 2001). Until now, however, there has been no investigation linking circadian rhythms and sialylation in *Drosophila*.

Previous behavior studies involving DSiaT mutant flies revealed a temperature sensitive paralysis and defects in the amplitude of excitatory junction potentials (EJPs) (Repnikova et al., 2010). Paralysis of the DSiaT mutants commenced after about 5-6 minutes in a 38°C environment whereas wildtype and rescue flies showed no signs of paralysis up to 20 minutes in this same environment. Decreased amplitude of EJPs was also discovered in DSiaT mutants. This indicated that there was a defect in the NMJs synaptic transmission and/or the excitability of the axonal membrane was compromised (Repnikova et al., 2010).

NMJs include synapses between a motor neuron and a muscle cell. When a motor neuron is activated by converging synaptic input, action potentials are activated. These action potentials are large changes in the membrane potential, which ultimately leads to muscle contraction. EJPs are seen as changes in membrane potential, therefore, changes in the amplitude of EJPs can indicate a defect in synaptic function and structure (Germann and Stanfield, 2005). Evoked EJPs were analyzed by electrophysiological approaches using

extracellular nerve stimulation, and they were measured in the dorsal abdominal muscle 1 of third instar larvae in DSiaT mutant larvae (Repnikova et al., 2010). Spontaneous background synaptic transmission can be examined by investigating mini-EJPs (Verstreken and Bellen, 2001). DSiaT mutant larvae, however, did not show any changes in mini-EJPs.

In the present study, I reveal a novel phenotype that implicates sialylation is important for *Drosophila* circadian rhythms. This examination explores the effects of both DmCSAS and DSiaT on the circadian rhythms of *Drosophila*. Phenotypes involving temperature sensitive paralysis of DmCSAS mutant and double mutant (DmCSAS and DSiaT) flies were also examined along with defective EJPs in the DmCSAS mutant. Together, the characterization of these mutant phenotypes in *Drosophila* gives a unique understanding into the mechanisms involved in the sialylation pathway, and the complex way in which genes in this pathway interact.

MATERIALS AND METHODS

Drosophila strains and maintenance

Wildtype w^{1118} Canton-S were obtained from Josh Dubnau (Cold Spring Harbor Laboratory, Cold Spring Harbor, NY). MH wildtype and CSAS^{Mi} lines were obtained from the Bloomington Stock Center (Indiana University).

DSiaT-HA (KI48), DSiaT^{L22}, DSiaT^{S23}, CSAS^{R3}, and CSAS rescue flies were created in my laboratory (E. Repnikova and M. Nakamura). *Drosophila* stocks were maintained at room temperature (23°C), and cultured on standard cornmeal-malt-yeast medium unless otherwise stated.

DSiaT and circadian rhythm co-localization

DSiaT localization to neuronal clock cells was performed using PDF and HA antibodies in KI48 (HA tagged DSiaT) flies. KI48 was created as described in (Repnikova et al., 2010). The purpose of this staining was to examine potential co-localization between neuronal clock cells (PDF) and DSiaT.

Primary antibodies used were rat anti-HA (1:800) (Roche) and mouse anti-PDF C7 (1:5) (Developmental Studies Hybridoma Bank). Secondary antibodies were anti-rat Cy3 (1:250) (Jackson Laboratories) and Alexa anti-mouse 488 (1:250) (Jackson Laboratories).

Stainings were performed by E. Repnikova as described in the 'Immunohistochemistry' section in chapter II.

Circadian rhythm assay

All mutant strains used in this experiment were first outcrossed for 10 generations to the MH wildtype strain to minimize any possible genetic background influence. DSiaT^{S23}, CSAS^{Mi}, and MH wildtype 1-2 day old male flies were used in the circadian rhythm assays. All strains were reared in a controlled

25°C, 35% humidity, and 12 hour light/dark environment on a standard cornmeal-malt-yeast medium. CSAS^{Mi} is a loss-of-function or strong hypomorphic allele containing a Minos transposable element. This line was generated by the Gene Disruption Project and has no published data available. DSiaT^{S23} is a loss-of-function allele containing two premature stop codons within the DSiaT gene ORF (Repnikova et al., 2010). Assays were performed at (and with the generous help and assistance from) Dr Paul Hardin's lab. Flies were individually placed in *Drosophila* activity monitors, and they were entrained for 3 days in LD (12 hour light/12 hour dark) cycles. Each strain was then subjected to 7 days of DD (complete darkness). Activity was measured by counting the number of infrared beam breaks every 30 minutes and was analyzed with Clocklab software. MH; DSiaT^{S23};p[III] (rescue flies) and MH;p[III] flies were also assayed as controls (data not shown). These flies had no observable difference from MH wildtype circadian rhythms.

Electrophysiology

Electrophysiology was performed as described in Repnikova et al., 2010. Procedures were performed in (and with the generous help and assistance from)

Dr Mark Zoran's lab. Miniature EJP amplitudes were not able to be completed due to noise interference. Ten third instar larvae were used for each of the larval lines. w^{1118} Canton-S flies were used as the control, and CSAS^{Mi} and DSiaT^{S23} were the experimental lines. All lines were reared in a controlled 25°C, 35% humidity, and 12 hour light/dark incubator on a standard cornmeal-malt-yeast medium.

Temperature sensitive paralysis assay

Assays were performed as described in Repnikova et al., 2010. All flies were aged to five days. Wildtype w^{1118} Canton-S was used as the control. CSAS^{Mi} revertants and CSAS rescue flies were also examined. The rescue line was generated through overexpression of a UAS-CSAS line with a C155 pan-neuronal driver. The revertant (CSAS^{R3}) was created by excision of the Minos transposon in CSAS^{Mi}. CSAS^{Mi} and DSiaT^{S23} single mutants were assayed along with DSiaT^{S23};CSAS^{Mi} double mutants for the experimental lines. All assays were performed by M. Nakamura.

RESULTS

The potential function of sialylation in the regulation of circadian rhythms, to my knowledge, has never been investigated before. The rationale behind my experiments came from an immunostaining performed by a former colleague in my lab, E. Repnikova. This staining showed the potential interaction between sialylation and circadian rhythms by determining whether DSiaT was present in cells that control locomotor activity rhythms. Pigment dispersing factor, or PDF, are neuropeptides expressed by circadian pacemaker neurons. These neuropeptides have been found to be important in morning anticipation and free-running rhythms (Zhang et al., 2010). HA tagged DSiaT flies (KI48) (Repnikova et al., 2010) were stained with HA and PDF antibodies to reveal co-localization between DSiaT and clock neurons in the larval brain hemispheres of the CNS (Figure 14). These preliminary results suggested that sialylation could play a role in the regulation of clock neurons and the circadian activity of *Drosophila*.

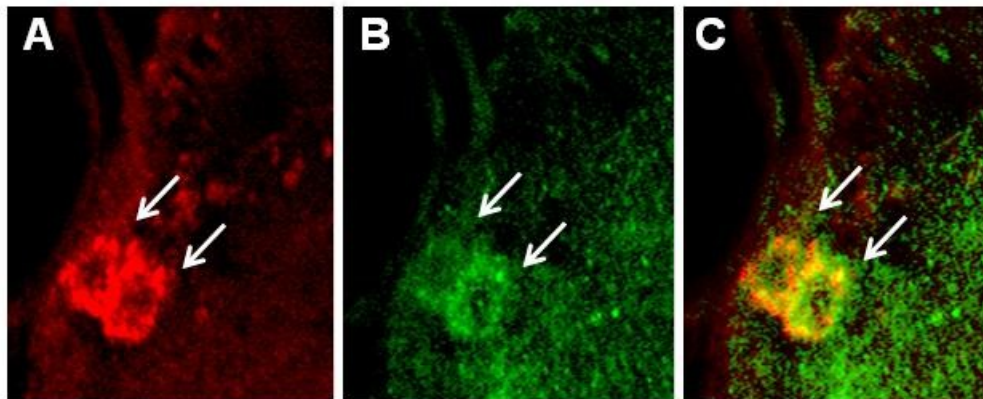

Figure 14. DSiaT is localized to neuronal clock cells (unpublished data of E. Repnikova).

A, Expression of PDF neuronal clock cells.

B, Expression of DSiaT in the larval brain hemisphere.

C, Co-localization (seen in yellow) of PDF and DSiaT in the CNS.

White arrows indicate cells where expression occurred.

Images obtained using 40X objective magnification.

From this preliminary data, I decided to examine the rhythmic activity in 4-10 day old CSAS^{Mi} and DSiaT^{S23} mutant flies. CSAS^{Mi} is a loss-of-function or strong hypomorphic allele containing a Minos transposable element in the second intron of the CSAS gene on chromosome 3. DSiaT^{S23} is a loss-of-function allele containing two premature stop codons within the DSiaT gene ORF (Repnikova et al., 2010). Flies were entrained for 3 days in a 12 hour light/dark cycle (LD cycle) before being subjected to complete darkness for 7 days (DD). Activity of each fly was measured over this 10 day period and analyzed. Data revealed that DSiaT^{S23} mutant flies retained their rhythmic locomotor activity in full darkness after LD entraining. Most CSAS^{Mi} mutant flies, however, were not able to maintain this rhythmic cycle (Figure 15).

Due to the co-localization between neuronal clock cells and DSiaT, and the rhythmic behavior of DSiaT^{S23} mutant flies, I decided to look further into the characteristics of the DSiaT^{S23} mutant flies' circadian rhythms. Actograms are graphs that represent the activity of an organism over time. After averaging the flies for both wildtype and DSiaT^{S23} mutants, an actogram was produced. This graph revealed a circadian rhythm phenotype with the DSiaT^{S23} mutant flies. DSiaT^{S23} mutants do maintain rhythmicity; however, their rhythmic cycles start to shift over time whereas wildtype flies maintain their rhythmic cycles at approximately the same time throughout the assay (Figure 16).

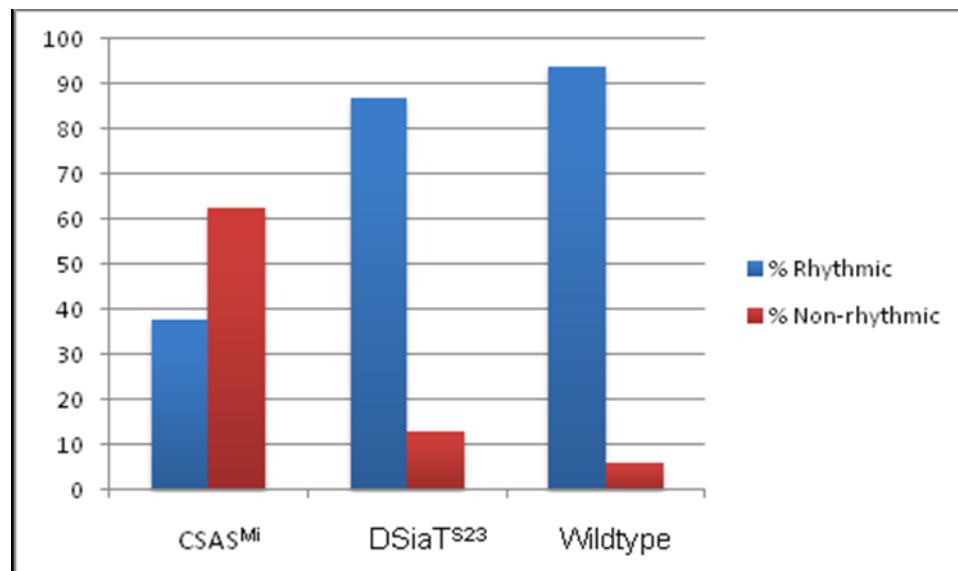

Figure 15. DmCSAS mutants have a non-rhythmic phenotype. After 3 days of entrainment (LD cycle), Many CSAS^{Mi} mutant flies were not able to maintain rhythmicity when subjected to complete darkness (DD cycle) for 7 days. DSiaT^{S23} mutants, however, remained rhythmic. Data represents 16 flies for CSAS^{Mi} and wildtype flies, and 15 flies for DSiaT^{S23}.

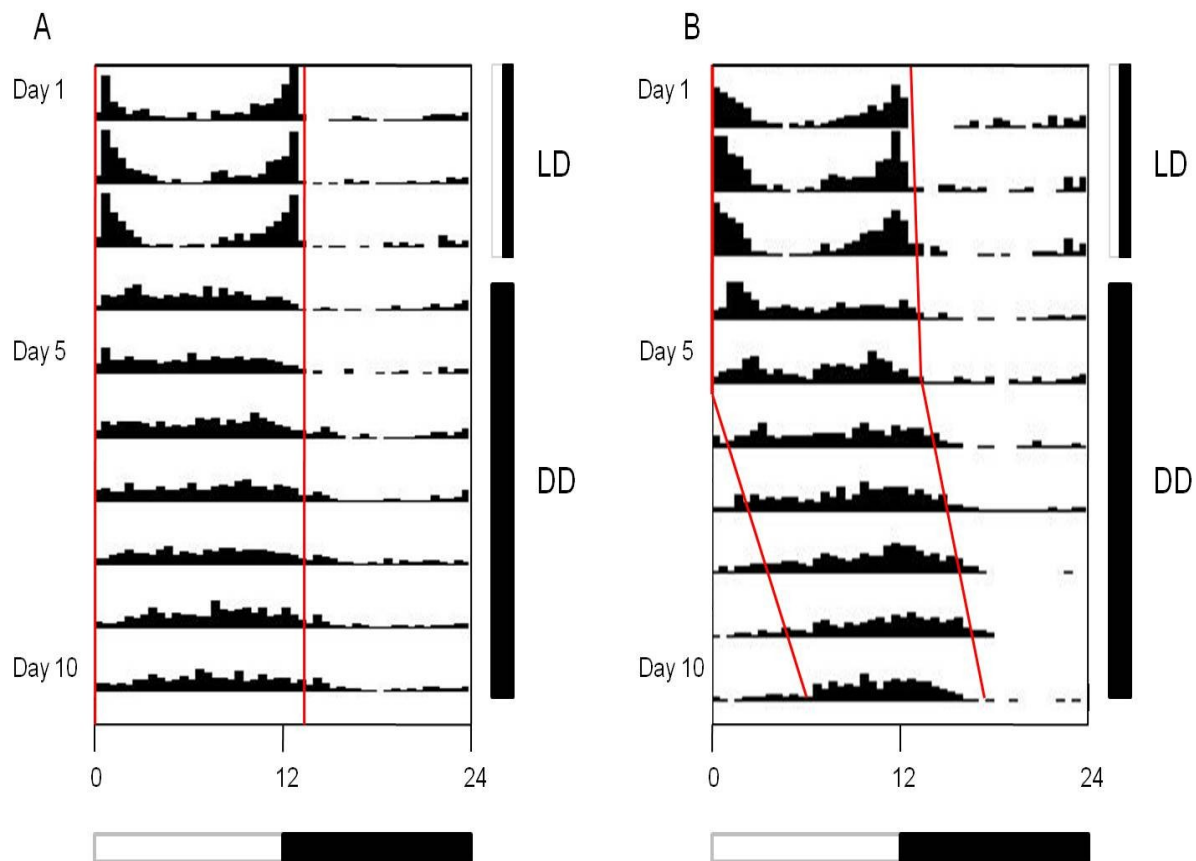

Figure 16. $DSiaT$ mutant flies have a shift in their circadian rhythms over time. **A**, Averaged activity for 16 flies over 10 days for wildtype flies. **B**, Averaged activity for 15 flies over 10 days for $DSiaT^{S23}$ mutant flies. White and black bars at the bottom of each actogram represent when lights were on and when lights were off, respectively, during the LD entrainment period. Red lines indicated approximate areas where increased activity begins and ends.

Additionally, DSiaT^{S23} mutant flies had a high lethality during the behavior run unlike all other genotypes assayed. Over 60 DSiaT^{S23} mutant flies were assayed, yet only 15 yielded useable data. A majority of these flies died around 1-2 days before the end of the assay. DSiaT^{S23} mutant flies do have decreased longevity (Repnikova et al., 2010); however, the phenotype was not nearly as severe as seen here. It is still unclear as to the reason why this severe decreased longevity phenotype was witnessed.

Circadian periods for my data all ranged within the typical 24 hour period. The Wildtype average period was 24.1, DSiaT^{S23} average period was 24.4, and the rhythmic CSAS^{Mi} average period was 24.1. The overall average period for CSAS^{Mi} including non-rhythmic flies was 23.8. With these periods all averaging to approximately the same time, it can be inferred that the phenotypes discovered are in fact real. The circadian mutant phenotypes are due to the effect of sialylation on circadian rhythms, and not due to changes in periods caused by the mutations.

After examining sialylation at an organismal level with my circadian rhythm assay, I wanted to investigate sialylation in *Drosophila* at a cellular level. One way to accomplish this is with electrophysiology. I wanted to examine the effect DmCSAS has on the EJPs of *Drosophila*, as well as the relationship between DmCSAS and DSiaT with respect to EJP phenotype. As previously discussed, DSiaT mutant flies exhibited a defect in their EJP amplitudes (Repnikova et al., 2010). Here, in collaboration with my colleague Rafique Islam,

I used electrophysiology to investigate DmCSAS mutant third instar larvae (CSAS^{Mi}) together with DSiaT mutant third instar larvae (DSiaT^{S23}) in both dorsal abdominal muscle 1 and muscle 6. DSiaT^{S23} larvae previously had shown a decrease in EJP amplitude in muscle 1, but relatively normal EJP amplitude in muscle 6 when compared to wildtype flies (Repnikova et al., 2010). Interestingly, I found that DmCSAS mutants demonstrate a more severe decrease in EJP amplitude in muscle 1 NMJ when compared to DSiaT mutants. Moreover, in contrast to DSiaT mutants that were previously found to have normal EJP at muscle 6 NMJ, DmCSAS mutants had a decrease in EJP amplitude at this NMJ (Figure 17). These phenotypes were intriguing as the sialylation pathway in *Drosophila* (and vertebrates) involving the CSAS and SiaT genes is presumed to be linear (see Figure 2), in which SiaT functions downstream of CSAS. Losing the function of DmCSAS should not affect the phenotypic outcome any more than losing the function of DSiaT. This phenotypic discovery suggested that DmCSAS and DSiaT may actually have some independent functions from one another.

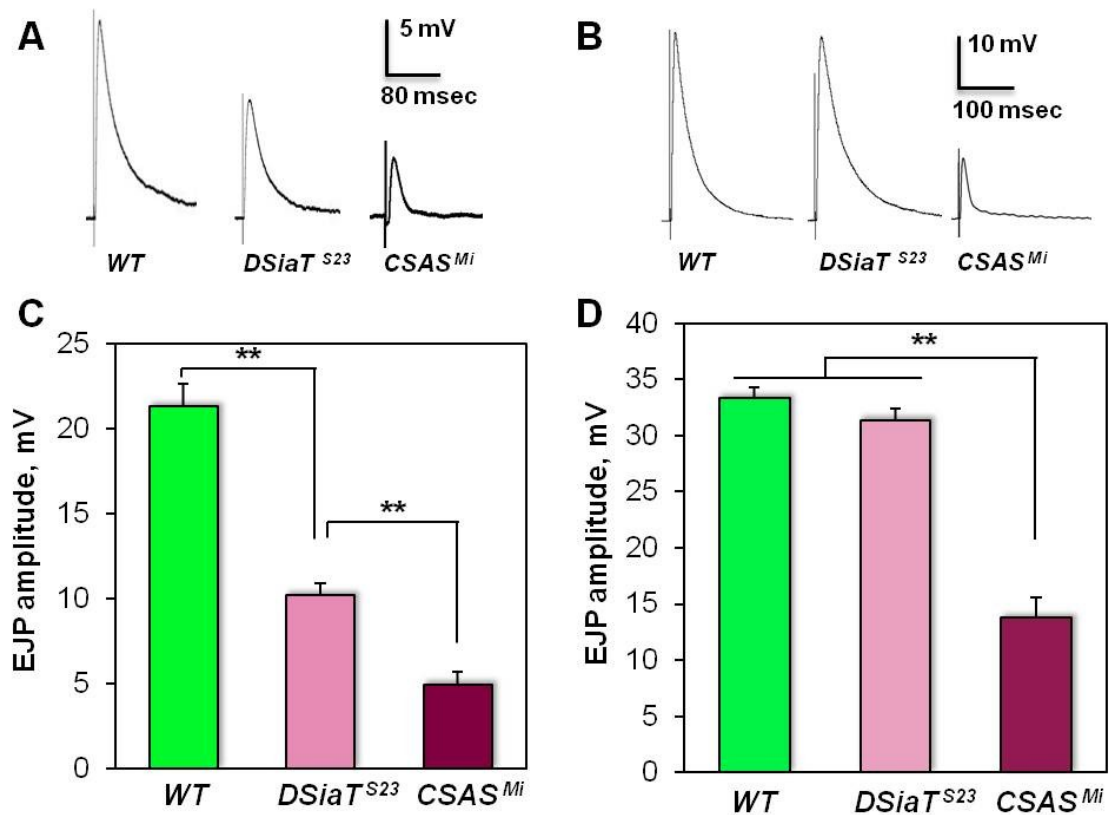

Figure 17. DmCSAS mutants have defects in EJP amplitude in muscle 1 and muscle 6 (results of collaborative experiments with R. Islam).

A, Representative traces of evoked EJPs from muscle 1.

B, Representative traces of evoked EJPs from muscle 6.

C, Evoked EJP amplitude in muscle 1.

D, Evoked EJP amplitude in muscle 6

Error bars are SEM.

** indicates statistically significant differences (t test, $p < 0.01$).

Further data to support the idea of independent functions occurring between DmCSAS and DSiaT was found in my lab by M. Nakamura. This was done by examining DmCSAS mutant flies for possible temperature sensitive paralysis. This phenotype was already shown to be present in DSiaT mutant flies (Repnikova et al., 2010). DmCSAS and DSiaT were tested by using single mutant CSAS^{Mi}, single mutant DSiaT^{S23}, and double mutant DSiaT^{S23};CSAS^{Mi} flies. Data showed that single mutant DSiaT^{S23} and CSAS^{Mi} flies have a similar temperature sensitive paralysis when exposed to a 38°C environment (Figure 18). Both mutants exhibited paralysis at around 5 minutes. Interestingly, DSiaT^{S23};CSAS^{Mi} flies revealed a more severe phenotype than either single mutant with paralysis ensuing after approximately 2 minutes in the same 38°C environment (Figure 18).

The double mutant phenotype is very intriguing because, again, if the sialylation pathway in *Drosophila* is linear between CSAS and SiaT, then losing the function of DmCSAS should not affect the phenotypic outcome any more than losing the function of DSiaT. Therefore, double mutants should have the same phenotypic outcome as either of the single mutants assuming a linear pathway. This more severe phenotype in the double mutant line further supports the notion that perhaps DmCSAS and DSiaT have some independent functions from one another.

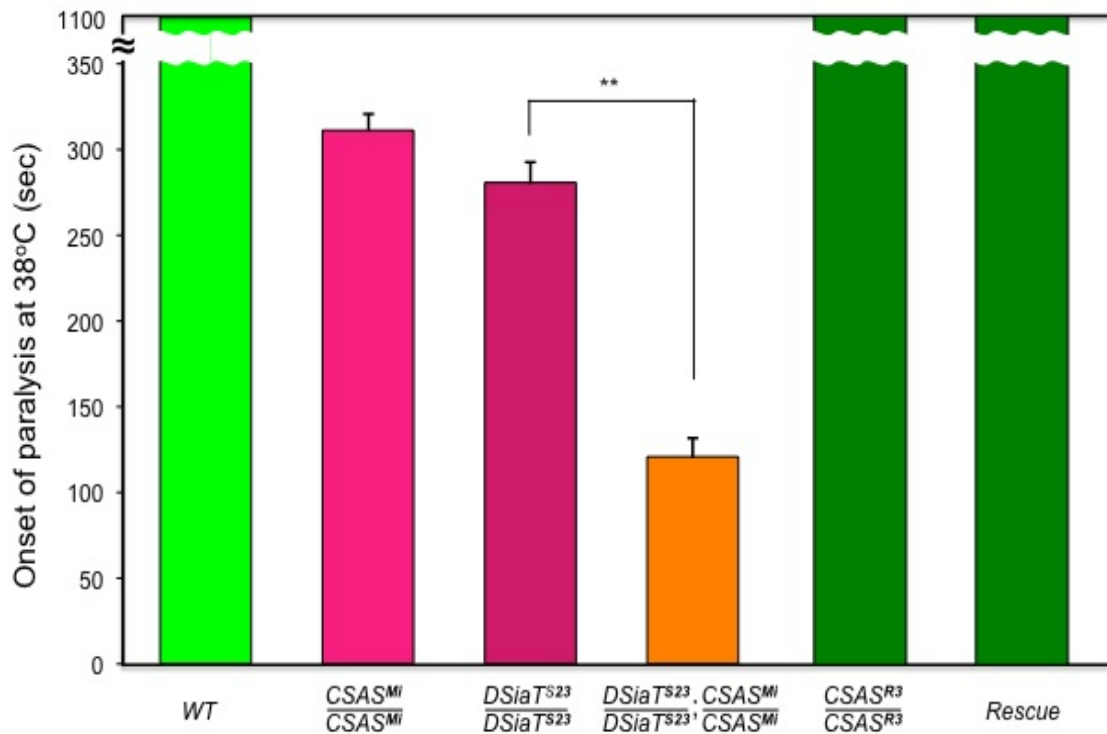

Figure 18. Temperature sensitive paralysis of DmCSAS, DSiaT, and double mutant DSiaT;DmCSAS flies (unpublished data of M. Nakamura). Wildtype, CSAS revertants, and rescue flies all showed no signs of paralysis after 20 minutes in a 38°C environment. $CSAS^{Mi}$ and $DSiaT^{S23}$ single mutants exhibited paralysis after approximately 5 minutes. Double mutants, however, had a more severe phenotype with paralysis ensuing after approximately 2 minutes of exposure to a 38°C environment. Error bars are SEM.

** indicates statistically significant differences (t test, $p < 0.01$).

DISCUSSION

In this chapter, I have attempted to answer important questions concerning the characteristics of mutant phenotypes in both DmCSAS and DSiaT mutants. Specific questions that have been addressed in this chapter include: Does sialylation affect circadian rhythms in *Drosophila*? Do DmCSAS mutants have defective EJPs? Do DmCSAS mutants have temperature sensitive paralysis? What is the relationship between DSiaT and DmCSAS? The answers uncovered have led to a novel and unexpected understanding of the sialylation pathway in *Drosophila*.

Co-localization of DSiaT and clock neuronal cells first suggested to me that sialylation might be involved in the regulation of clock neurons and circadian rhythms. Further experimentation revealed a novel phenotype associated with both DmCSAS and DSiaT mutant flies. The phenotypes uncovered are unique to each gene, and the differences suggest that DmCSAS and DSiaT could have some independent functions. DmCSAS mutant flies had a more pronounced mutant phenotype with many DmCSAS mutants losing the ability to control output of the clock. In other words, many of these flies became arrhythmic, losing the ability to maintain a circadian rhythm. However, DSiaT mutants were able to maintain their rhythmic cycles. It was instead discovered that the circadian rhythms of these DSiaT mutant flies began to shift as time in complete darkness (DD) continued. At this point, the mechanism of the possible effect of sialylation on circadian rhythms remains obscure. PDF is required for free

running locomotor activity and morning anticipation peaks of activity (Zhang et al., 2010), and DSiaT and PDF were shown to co-localize to the same areas of the larval CNS. It can be hypothesized that sialylation somehow affects the circadian fluctuations of the expression of PDF, which is normally released rhythmically (Hardin, 2005). Perhaps PDF, a neuropeptide, is in fact a target for sialylation in *Drosophila*. Much more investigation into this is still needed, but my current results do suggest a novel role of sialylation in the regulation of circadian rhythms in *Drosophila*. They also suggest an exciting new approach to understanding the sialylation pathway in humans using *Drosophila* as a model.

Electrophysiological data revealed that DmCSAS mutants have defects of EJP amplitude at larval NMJs. This defect indicates that the excitability of the axonal membrane and/or NMJ synaptic transmission is compromised (Repnikova et al., 2010). Interestingly, my results suggested that DmCSAS and DSiaT have some independent functions of one another. DmCSAS mutants were found to have a more severe phenotype than DSiaT mutants in muscle 1 NMJ. Additionally, DmCSAS mutants also had decreased EJP amplitudes in muscle 6, which is a defect that is absent in DSiaT mutants.

Further evidence proposing some independent functions between DmCSAS and DSiaT involved using DmCSAS and DSiaT mutant and double mutant flies to assess and characterize a temperature sensitive paralysis phenotype (results by M. Nakamura). This behavioral assay revealed an intriguing new relationship between DSiaT and DmCSAS. The idea of DmCSAS

and DSiaT having some independent functions to one another seems likely considering the fact that DmCSAS;DSiaT double mutant flies were shown to have a more severe phenotype than either of the single mutants.

After analyzing the mutant phenotypes I have concluded that the relationship between DmCSAS and DSiaT is clearly more complex than originally conceived. Based on the differences in circadian rhythm phenotypes, increased severity of the DmCSAS mutant's EJP defects, and increased severity of temperature sensitive paralysis in the DmCSAS;DSiaT double mutant, I can propose that DmCSAS and DSiaT have some independent functions from each other. At the same time, the similarity of mutant phenotypes of DSiaT and DmCSAS and their genetic interactions indicate that these two genes are involved in the same functional pathway that regulates the nervous system in *Drosophila*, which is consistent with my previous conclusions in chapter II.

CHAPTER IV

CONCLUSION

Glycobiology is a relatively new field of modern biology that has only started to emerge from obscurity in recent years (Varki, 2008). Sialylation is one of the important topics in this field, representing an evolutionarily conserved pathway involved in several crucial developmental and physiological processes in animals. The presence of sialylation has been shown to be in almost all evolutionary classes of life forms. From bacteria and fungi to protostomes and vertebrates, sialylation is an essential element to understanding the basics of life.

With any type of scientific investigation, model organisms become an indispensable tool in the research process. In order to understand the mechanisms of sialylation in humans, scientists can turn to a reliable, useful model organism sharing a similarity between the human sialylation process and the model. Available research strategies for studying mammalian organisms have prominent obstacles. The complexity of the nervous system, functional and genetic redundancy, and limitations to genetic approaches all make mammalian organisms a less than ideal model system for revealing neural functions of sialic acids. *Drosophila*, however, has emerged as a unique, reliable, and useful model organism with many similarities between its sialylation pathway and that of vertebrates (Koles et al., 2009; Repnikova et al., 2010). My current

investigations utilize the uniqueness of the *Drosophila* model system to explore the mechanisms and functions of sialylation, specifically that of DmCSAS and DSiaT.

EXPRESSION PATTERN OF DmCSAS

In situ hybridization revealed that DmCSAS is expressed throughout development in the embryonic, larval, and adult CNS. This allowed me to conclude that DmCSAS, like DSiaT, is involved in a developmentally regulated, tissue specific process whose function is probably concentrated on the regulation of the nervous system. My experiments also revealed a unique and complex expression pattern for DmCSAS. This pattern has similar but also distinct features compared to that of DSiaT expression. This suggested the possibility that DmCSAS and DSiaT have some independent functions in the *Drosophila* CNS. In addition, I found an unusual putative localization of DmCSAS transcript to cellular processes and synaptic connections, which suggested that this gene plays a role in synaptic transmission.

SUB-CELLULAR LOCALIZATION

Golgi localization had never been confirmed *in vivo* in the *Drosophila* brain before. Using a Golgi marker along with the ectopic expression of

DmCSAS, I have revealed that the DmCSAS protein localizes in the Golgi of *Drosophila* CNS neurons. However, my results also suggested that DmCSAS is present outside of the Golgi compartment, which will need to be investigated further. It can be concluded the localizations seen outside the Golgi might represent enzymatically inactive forms of DmCSAS as it has already been shown that Golgi localization is important for the enzymatic activity of DmCSAS (Viswanathan et al., 2006).

Sub-cellular localization to synapses was also discovered using co-immunolabeling with a synaptic marker. This finding is consistent with my data from the *in situ* hybridization experiments, which suggested that DmCSAS may have some function in synapses.

Additionally, I examined the sub-cellular co-localization between DmCSAS and DSiaT in the CNS and the Golgi of salivary glands. My experiments divulged that DmCSAS and DSiaT are co-localized within some neuronal cells, but not all of them. This result suggests a possibility that these proteins may physically interact and/or participate in the same molecular complex, possibly associated with sialylation activity. I also discovered that some of these neuronal cells appear to lack both proteins; expressing only DSiaT or only DmCSAS. The lack of expression of both DSiaT and DmCSAS in some of these cells most likely demonstrates the post-transcriptional regulation of the DmCSAS and DSiaT proteins. I also showed that there is nearly perfect co-localization between DmCSAS and DSiaT within the Golgi of salivary gland

cells, which further confirmed the Golgi localization of DmCSAS and putative interaction between DmCSAS and DSiaT. Caution should be taken, however, with the sub-cellular evidence presented. All expression was obtained ectopically using a UAS-Gal4 driver system. Although reliable, these results are currently being confirmed via endogenous expression (see Appendix A).

My experiments demonstrated that the *Drosophila* sialylation pathway is a unique and complex mechanism that possibly relies on the regulation of sub-cellular localization of DmCSAS. Based on the restricted expression of DmCSAS in the CNS at embryonic and larval stages revealed by *in situ* hybridization and the co-localization between DmCSAS and DSiaT expression in some neuronal cells, I can suggest that DmCSAS and DSiaT participate in the same regulatory pathway in the CNS. Similar to DSiaT, DmCSAS probably functions in the nervous system in a developmentally regulated and cell-specific manner.

CIRCADIAN RHYTHM ASSAY

Co-localization between DSiaT and clock neuronal cells gave me the first indication about the possible involvement of sialylation in circadian rhythms. After exploring this further I found a novel phenotype associated with both DmCSAS and DSiaT mutant flies. Interestingly, the phenotypes of DmCSAS and DSiaT are different from one another. DmCSAS mutants showed arrhythmic behavior whereas DSiaT mutants demonstrated rhythmic behavior but an

inability to keep the “correct time”. The difference in phenotypes further adds to the evidence of a complex relationship and some possible independent functions of DmCSAS and DSiaT. I can conclude from this experiment that sialylation does in fact have an effect on circadian rhythms. The mechanism of this effect is still unclear, however. One hypothesis is that sialylation somehow affects the circadian fluctuations of PDF expression, which is normally released rhythmically (Hardin, 2005). PDF is a neuropeptide required for free running locomotor activity and morning anticipation peaks of activity (Zhang et al., 2010). DSiaT and PDF were shown to co-localize to the same cells, which supports this hypothesis. This result also suggests that perhaps PDF is in fact a target for sialylation in *Drosophila*. These exciting findings reveal that more research is still needed, while also suggesting that *Drosophila* could be a useful model for studying neural functions of sialylation evolutionarily conserved between *Drosophila* and vertebrates.

ELECTROPHYSIOLOGY

Through electrophysiology I was able to determine that DmCSAS mutants have defects in their EJP amplitudes. These results are consistent with the defect in EJP amplitude found in DSiaT mutants, and indicate that DmCSAS is involved in the excitability of the axonal membrane and/or NMJ synaptic transmission (Repnikova et al., 2010). However, the experiment also uncovered

DmCSAS mutants to have more severe defects of NMJ electrophysiology as compared to DSiaT. These data provide further evidence that DmCSAS and DSiaT probably function in the same pathway, while also having some independent roles in the CNS. These conclusions are consistent with other results from my laboratory, including data on the temperature-induced paralysis phenotype of DmCSAS mutants (see Figure 18).

RELATIONSHIP BETWEEN DmCSAS AND DSiaT

Together with *in situ* hybridization expression patterns, sub-cellular co-localization of DmCSAS and DSiaT in the CNS, differences in circadian rhythm phenotypes, increased temperature sensitive paralysis in the double mutant, and electrophysiological data showing a more severe phenotype associated with DmCSAS mutations, I can conclude that the relationship between DmCSAS and DSiaT is complex, and that they probably have some independent functions (Figure 19). This novel conclusion could also indicate possible independent functions in the vertebrate sialylation pathway that are currently undiscovered. It is still unclear as to what these independent functions in *Drosophila* are; however, I can propose a few hypotheses: 1. DmCSAS may create another donor sugar 2. There could be another DSiaT that is yet undiscovered 3. DSiaT might have another donor sugar that it modifies 4. DSiaT may function not just as an enzyme, but in directly binding the sugar as well.

Additionally, I find strong evidence that these two genes do in fact genetically interact, and that DmCSAS, similarly to DSiaT, is involved in a tissue specific, developmentally regulated mechanism that controls the function of the nervous system in *Drosophila*.

My experiments indicated that *Drosophila* can be a useful and convenient model organism for studying the complex mechanism of sialylation at cellular and organismal levels. It's only a matter of time before even more information about sialylation is garnered from these unique little flies. Bringing with it an evolutionary knowledge of how our own sialylation came to be and the functions behind it. Overall, the conclusions from this study have given a powerful new understanding of the functions of sialylation in *Drosophila*.

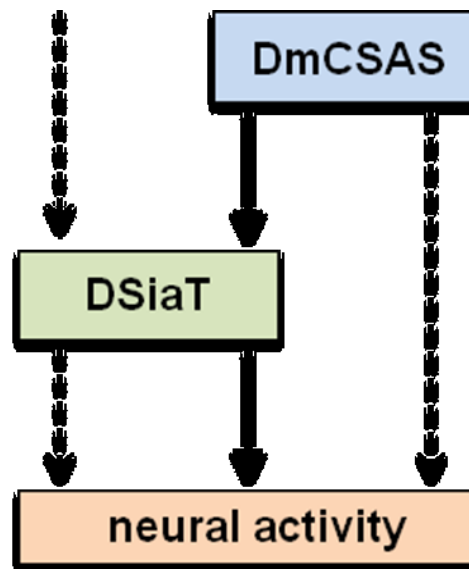

Figure 19. Proposed relationship between DmCSAS and DSiaT. Dashed lines indicate proposed independent function between DmCSAS and DSiaT as acquired by this investigation.

REFERENCES

- Alexander DA, Dimock K (2002) Sialic acid functions in enterovirus 70 binding and infection. *J Virol* 76:11265-11272.
- Angata K, Suzuki M, Fukuda M (2002) ST8Sia II and ST8Sia IV polysialyltransferases exhibit marked differences in utilizing various acceptors containing oligosialic acid and short polysialic acid. The basis for cooperative polysialylation by two enzymes. *J Biol Chem* 277:36808-36817.
- Angata T, Varki A (2002) Chemical diversity in the sialic acids and related alpha-keto acids: an evolutionary perspective. *Chem Rev* 102:439-469.
- Angata T, Nakata D, Matsuda T, Kitajima K, Troy FA, 2nd (1999) Biosynthesis of KDN (2-keto-3-deoxy-D-glycero-D-galacto-nononic acid). Identification and characterization of a KDN-9-phosphate synthetase activity from trout testis. *J Biol Chem* 274:22949-22956.
- Aoki K, Perlman M, Lim JM, Cantu R, Wells L, Tiemeyer M (2007) Dynamic developmental elaboration of N-linked glycan complexity in the *Drosophila melanogaster* embryo. *J Biol Chem* 282:9127-9142.
- Ben-Shlomo R, Kyriacou CP (2002) Circadian rhythm entrainment in flies and mammals. *Cell Biochem Biophys* 37:141-156.
- Butters TD, Hughes RC, Vischer P (1981) Steps in the biosynthesis of mosquito cell membrane glycoproteins and the effects of tunicamycin. *Biochim Biophys Acta* 640:672-686.
- Chiricolo M, Malagolini N, Bonfiglioli S, Dall'Olio F (2006) Phenotypic changes induced by expression of beta-galactoside alpha2,6 sialyltransferase I in the human colon cancer cell line SW948. *Glycobiology* 16:146-154.
- Comb DG, Shimizu F, Roseman S (1959) Isolation of cytidine-5'-monophospho-N-acetylneuraminic acid. *J Am Chem Soc* 81:5513-5514.
- Comb DG, Watson DR, Roseman S (1966) The sialic acids. IX. Isolation of cytidine 5'-monophospho-N-acetylneuraminic acid from *Escherichia coli* K-235. *J Biol Chem* 241:5637-5642.
- Crocker PR, Paulson JC, Varki A (2007) Siglecs and their roles in the immune system. *Nat Rev Immunol* 7:255-266.

- Dang DT, Perrimon N (1992) Use of a yeast site-specific recombinase to generate embryonic mosaics in *Drosophila*. *Dev Genet* 13:367-375.
- Davis JA, Wu XH, Wang L, DeRossi C, Westphal V, Wu R, Alton G, Srikrishna G, Freeze HH (2002) Molecular cloning, gene organization, and expression of mouse Mpi encoding phosphomannose isomerase. *Glycobiology* 12:435-442.
- Effertz K, Hinderlich S, Reutter W (1999) Selective loss of either the epimerase or kinase activity of UDP-N-acetylglucosamine 2-epimerase/N-acetylmannosamine kinase due to site-directed mutagenesis based on sequence alignments. *J Biol Chem* 274:28771-28778.
- Germann WJ, Stanfield CL (2005) Principles of human physiology. 2nd ed. San Francisco: Pearson Benjamin Cummings.
- Ghalambor MA, Heath EC (1966) The biosynthesis of cell wall lipopolysaccharide in *Escherichia coli*. IV. Purification and properties of cytidine monophosphate 3-deoxy-d-manno-octulosonate synthetase. *J Biol Chem* 241:3216-3221.
- Hardin PE (2005) The circadian timekeeping system of *Drosophila*. *Curr Biol* 15:R714-722.
- Harduin-Lepers A, Vallejo-Ruiz V, Krzewinski-Recchi MA, Samyn-Petit B, Julien S, Delannoy P (2001) The human sialyltransferase family. *Biochimie* 83:727-737.
- Hedlund M, Ng E, Varki A, Varki NM (2008) alpha 2-6-Linked sialic acids on N-glycans modulate carcinoma differentiation *in vivo*. *Cancer Res* 68:388-394.
- Hennet T, Chui D, Paulson JC, Marth JD (1998) Immune regulation by the ST6Gal sialyltransferase. *Proc Natl Acad Sci U S A* 95:4504-4509.
- Hinderlich S, Berger M, Keppler OT, Pawlita M, Reutter W (2001) Biosynthesis of N-acetylneuraminic acid in cells lacking UDP-N-acetylglucosamine 2-epimerase/N-acetylmannosamine kinase. *Biol Chem* 382:291-297.
- Hollister JR, Shaper JH, Jarvis DL (1998) Stable expression of mammalian beta 1,4-galactosyltransferase extends the N-glycosylation pathway in insect cells. *Glycobiology* 8:473-480.

- Hooker AD, Green NH, Baines AJ, Bull AT, Jenkins N, Strange PG, James DC (1999) Constraints on the transport and glycosylation of recombinant IFN-gamma in Chinese hamster ovary and insect cells. *Biotechnol Bioeng* 63:559-572.
- Inoue S, Kitajima K (2006) KDN (deaminated neuraminic acid): dreamful past and exciting future of the newest member of the sialic acid family. *Glycoconj J* 23:277-290.
- Isaev D, Isaeva E, Shatskih T, Zhao Q, Smits NC, Shworak NW, Khazipov R, Holmes GL (2007) Role of extracellular sialic acid in regulation of neuronal and network excitability in the rat hippocampus. *J Neurosci* 27:11587-11594.
- Jarvis DL, Finn EE (1996) Modifying the insect cell N-glycosylation pathway with immediate early baculovirus expression vectors. *Nat Biotechnol* 14:1288-1292.
- Kean EL, Roseman S (1966) The sialic acids. X. Purification and properties of cytidine 5'-monophosphosialic acid synthetase. *J Biol Chem* 241:5643-5650.
- Kean EL, Munster-Kuhnel AK, Gerardy-Schahn R (2004) CMP-sialic acid synthetase of the nucleus. *Biochim Biophys Acta* 1673:56-65.
- Kim K, Lawrence SM, Park J, Pitts L, Vann WF, Betenbaugh MJ, Palter KB (2002) Expression of a functional *Drosophila melanogaster* N-acetylneuraminic acid (Neu5Ac) phosphate synthase gene: evidence for endogenous sialic acid biosynthetic ability in insects. *Glycobiology* 12:73-83.
- Koles K, Irvine KD, Panin VM (2004) Functional characterization of *Drosophila* sialyltransferase. *J Biol Chem* 279:4346-4357.
- Koles K, Repnikova E, Pavlova G, Korochkin LI, Panin VM (2009) Sialylation in protostomes: a perspective from *Drosophila* genetics and biochemistry. *Glycoconj J* 26:313-324.
- Koles K, Lim JM, Aoki K, Porterfield M, Tiemeyer M, Wells L, Panin V (2007) Identification of N-glycosylated proteins from the central nervous system of *Drosophila melanogaster*. *Glycobiology* 17:1388-1403.

- Krzewinski-Recchi MA, Julien S, Juliant S, Teinturier-Lelievre M, Samyn-Petit B, Montiel MD, Mir AM, Cerutti M, Harduin-Lepers A, Delannoy P (2003) Identification and functional expression of a second human beta-galactoside alpha2,6-sialyltransferase, ST6Gal II. *Eur J Biochem* 270:950-961.
- Lawrence SM, Huddleston KA, Tomiya N, Nguyen N, Lee YC, Vann WF, Coleman TA, Betenbaugh MJ (2001) Cloning and expression of human sialic acid pathway genes to generate CMP-sialic acids in insect cells. *Glycoconj J* 18:205-213.
- Lehmann R, Tautz D (1994) *In situ* hybridization to RNA. *Methods Cell Biol* 44:575-598.
- Ley K (2003) The role of selectins in inflammation and disease. *Trends Mol Med* 9:263-268.
- Liang F, Seyrantepe V, Landry K, Ahmad R, Ahmad A, Stamatos NM, Pshezhetsky AV (2006) Monocyte differentiation up-regulates the expression of the lysosomal sialidase, Neu1, and triggers its targeting to the plasma membrane via major histocompatibility complex class II-positive compartments. *J Biol Chem* 281:27526-27538.
- Lopez M, Tetaert D, Juliant S, Gazon M, Cerutti M, Verbert A, Delannoy P (1999) O-glycosylation potential of lepidopteran insect cell lines. *Biochim Biophys Acta* 1427:49-61.
- Loughney K, Kreber R, Ganetzky B (1989) Molecular analysis of the para locus, a sodium channel gene in *Drosophila*. *Cell* 58:1143-1154.
- Maliekal P, Vertommen D, Delpierre G, Van Schaftingen E (2006) Identification of the sequence encoding N-acetylneuraminase-9-phosphate phosphatase. *Glycobiology* 16:165-172.
- McEver RP (2002) Selectins: lectins that initiate cell adhesion under flow. *Curr Opin Cell Biol* 14:581-586.
- Munster-Kuhnel AK, Tiralongo J, Krapp S, Weinhold B, Ritz-Sedlacek V, Jacob U, Gerardy-Schahn R (2004) Structure and function of vertebrate CMP-sialic acid synthetases. *Glycobiology* 14:43R-51R.
- Nan X, Carubelli I, Stamatos NM (2007) Sialidase expression in activated human T lymphocytes influences production of IFN-gamma. *J Leukoc Biol* 81:284-296.

- Nilsson EC, Jamshidi F, Johansson SM, Oberste MS, Arnberg N (2008) Sialic acid is a cellular receptor for coxsackievirus A24 variant, an emerging virus with pandemic potential. *J Virol* 82:3061-3068.
- Olofsson S, Kumlin U, Dimock K, Arnberg N (2005) Avian influenza and sialic acid receptors: more than meets the eye? *Lancet Infect Dis* 5:184-188.
- Oschlies M, Dickmanns A, Haselhorst T, Schaper W, Stummeyer K, Tiralongo J, Weinhold B, Gerardy-Schahn R, von Itzstein M, Ficner R, Munster-Kuhnel AK (2009) A C-terminal phosphatase module conserved in vertebrate CMP-sialic acid synthetases provides a tetramerization interface for the physiologically active enzyme. *J Mol Biol* 393:83-97.
- Rafuse VF, Landmesser LT (2000) The pattern of avian intramuscular nerve branching is determined by the innervating motoneuron and its level of polysialic acid. *J Neurosci* 20:1056-1065.
- Repnikova E, Koles K, Nakamura M, Pitts J, Li H, Ambavane A, Zoran MJ, Panin VM (2010) Sialyltransferase regulates nervous system function in *Drosophila*. *J Neurosci* 30:6466-6476.
- Roseman S (1962) Enzymatic synthesis of cytidine 5'-mono-phospho-sialic acids. *Proc Natl Acad Sci U S A* 48:437-441.
- Roth J, Kempf A, Reuter G, Schauer R, Gehring WJ (1992) Occurrence of sialic acids in *Drosophila melanogaster*. *Science* 256:673-675.
- Rutishauser U (2008) Polysialic acid in the plasticity of the developing and adult vertebrate nervous system. *Nat Rev Neurosci* 9:26-35.
- Schauer R (2004) Sialic acids: fascinating sugars in higher animals and man. *Zoology (Jena)* 107:49-64.
- Schwarzkopf M, Knobloch KP, Rohde E, Hinderlich S, Wiechens N, Lucka L, Horak I, Reutter W, Horstkorte R (2002) Sialylation is essential for early development in mice. *Proc Natl Acad Sci U S A* 99:5267-5270.
- Shen H, Watanabe M, Tomasiewicz H, Glass JD (2001) Genetic deletions of NCAM and PSA impair circadian function in the mouse. *Physiol Behav* 73:185-193.
- Sink H, Rehm EJ, Richstone L, Bulls YM, Goodman CS (2001) sidestep encodes a target-derived attractant essential for motor axon guidance in *Drosophila*. *Cell* 105:57-67.

- Stasche R, Hinderlich S, Weise C, Effertz K, Lucka L, Moormann P, Reutter W (1997) A bifunctional enzyme catalyzes the first two steps in N-acetylneuraminic acid biosynthesis of rat liver. Molecular cloning and functional expression of UDP-N-acetyl-glucosamine 2-epimerase/N-acetylmannosamine kinase. *J Biol Chem* 272:24319-24324.
- Sullivan W, M.A., Hawley S (2008) *Drosophila* protocols. Cold Spring Harbor Laboratory Press. Cold Spring Harbor, NY.
- Takashima S, Tsuji S, Tsujimoto M (2002) Characterization of the second type of human beta-galactoside alpha 2,6-sialyltransferase (ST6Gal II), which sialylates Galbeta 1,4GlcNAc structures on oligosaccharides preferentially. Genomic analysis of human sialyltransferase genes. *J Biol Chem* 277:45719-45728.
- Taylor ME, Drickamer K (2003) Introduction to glycobiology. New York: Oxford University Press.
- Tomiya N, Ailor E, Lawrence SM, Betenbaugh MJ, Lee YC (2001) Determination of nucleotides and sugar nucleotides involved in protein glycosylation by high-performance anion-exchange chromatography: sugar nucleotide contents in cultured insect cells and mammalian cells. *Anal Biochem* 293:129-137.
- Varki A (1999) Essentials of glycobiology. Cold Spring Harbor, NY: Cold Spring Harbor Laboratory Press.
- Varki A (2008) Sialic acids in human health and disease. *Trends Mol Med* 14:351-360.
- Varki NM, Varki A (2007) Diversity in cell surface sialic acid presentations: implications for biology and disease. *Lab Invest* 87:851-857.
- Velasco A, Hendricks L, Moremen KW, Tulsiani DR, Touster O, Farquhar MG (1993) Cell type-dependent variations in the subcellular distribution of alpha-mannosidase I and II. *J Cell Biol* 122:39-51.
- Venken KJ, Kasprowicz J, Kuenen S, Yan J, Hassan BA, Verstreken P (2008) Recombinering-mediated tagging of *Drosophila* genomic constructs for *in vivo* localization and acute protein inactivation. *Nucleic Acids Res* 36:e114.
- Verstreken P, Bellen HJ (2001) Neuroscience. The meaning of a mini. *Science* 293:443-444.

- Viswanathan K, Tomiya N, Park J, Singh S, Lee YC, Palter K, Betenbaugh MJ (2006) Expression of a functional *Drosophila melanogaster* CMP-sialic acid synthetase. Differential localization of the *Drosophila* and human enzymes. *J Biol Chem* 281:15929-15940.
- Warren L, Blacklow RS (1962) The biosynthesis of cytidine 5'-monophospho-n-acetylneuraminic acid by an enzyme from *Neisseria meningitidis*. *J Biol Chem* 237:3527-3534.
- Weidemann W, Klukas C, Klein A, Simm A, Schreiber F, Horstkorte R (2010) Lessons from GNE-deficient embryonic stem cells: sialic acid biosynthesis is involved in proliferation and gene expression. *Glycobiology* 20:107-117.
- Zhan XL, Clemens JC, Neves G, Hattori D, Flanagan JJ, Hummel T, Vasconcelos ML, Chess A, Zipursky SL (2004) Analysis of Dscam diversity in regulating axon guidance in *Drosophila* mushroom bodies. *Neuron* 43:673-686.
- Zhang L, Chung BY, Lear BC, Kilman VL, Liu Y, Mahesh G, Meissner RA, Hardin PE, Allada R (2010) DN1(p) circadian neurons coordinate acute light and PDF inputs to produce robust daily behavior in *Drosophila*. *Curr Biol* 20:591-599.
- Zhang YQ, Rodesch CK, Broadie K (2002) Living synaptic vesicle marker: synaptotagmin-GFP. *Genesis* 34:142-145.

APPENDIX A

In an effort to further investigate DmCSAS on an endogenous level without the use of ectopic means, I have been focusing on creating a DmCSAS construct through recombineering-mediated tagging. This will allow my lab to detect endogenous levels of DmCSAS without affecting the expression or activity of the gene itself. I am following a method using a bacmid construct that will allow me to efficiently tag the DmCSAS protein (Venken et al., 2008). An outline of the strategy used can be seen in Figure 20. While it is not yet able to produce results, I am finishing up creating the construct itself. This new and powerful tool will lead to an even greater understanding of DmCSAS, and will allow scientists to perform many more investigations into the dynamics of DmCSAS in the sialylation pathway.

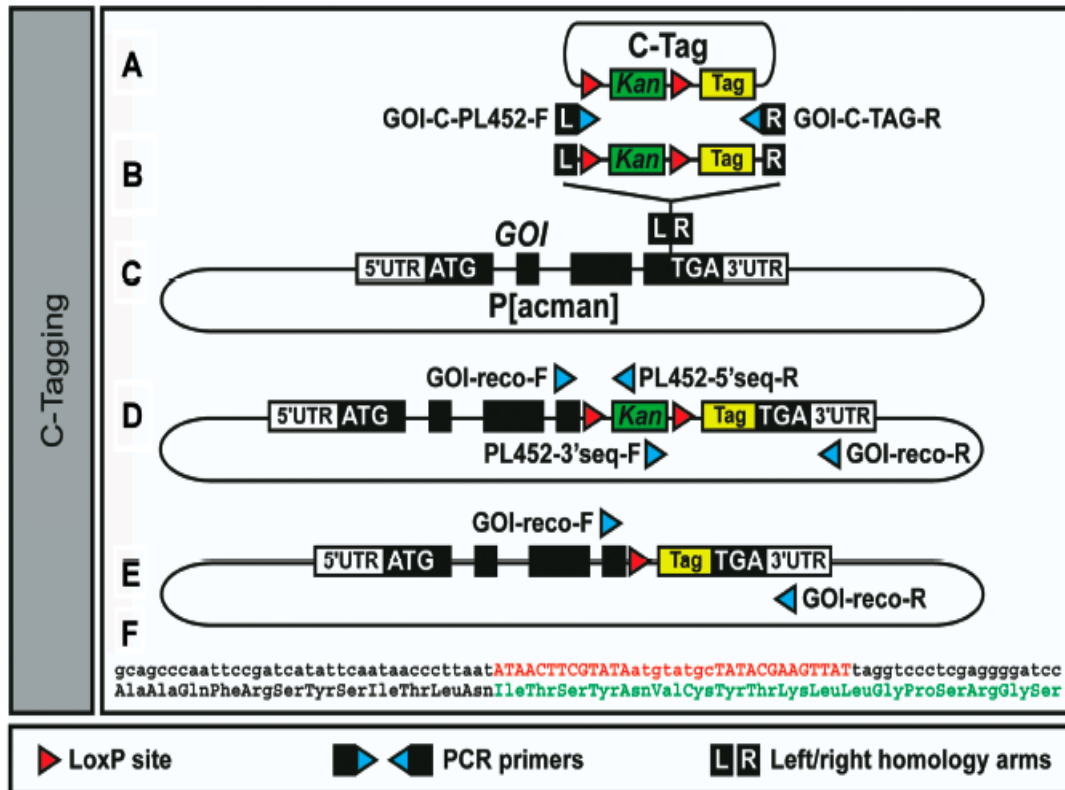

Figure 20. Representation of the strategy to create tagged DmCSAS. Modified from (Venken et al., 2008).

APPENDIX B

Another construct that will be ready to use, but currently is not able to produce publishable results is a flip-out construct. This construct is being created to investigate spatial and temporal control of DSiaT and DmCSAS *in vivo*. I am using FLP-FRT recombination to create this flip-out construct, which will allow me to “turn on or off” the expression of DSiaT or DmCSAS *in vivo*. Flippase (also called FLP-recombinase) can promote mitotic exchange between homologous chromosomes that contain FRT (FLP Recombination Target) sequences (Dang and Perrimon, 1992). I am using vectors from Thomas Osterwalder, which contain the FRT sites as well as the actin promoter sequences needed. I am then cloning DSiaT or DmCSAS into the vector to create the flip-out construct (Figure 21).

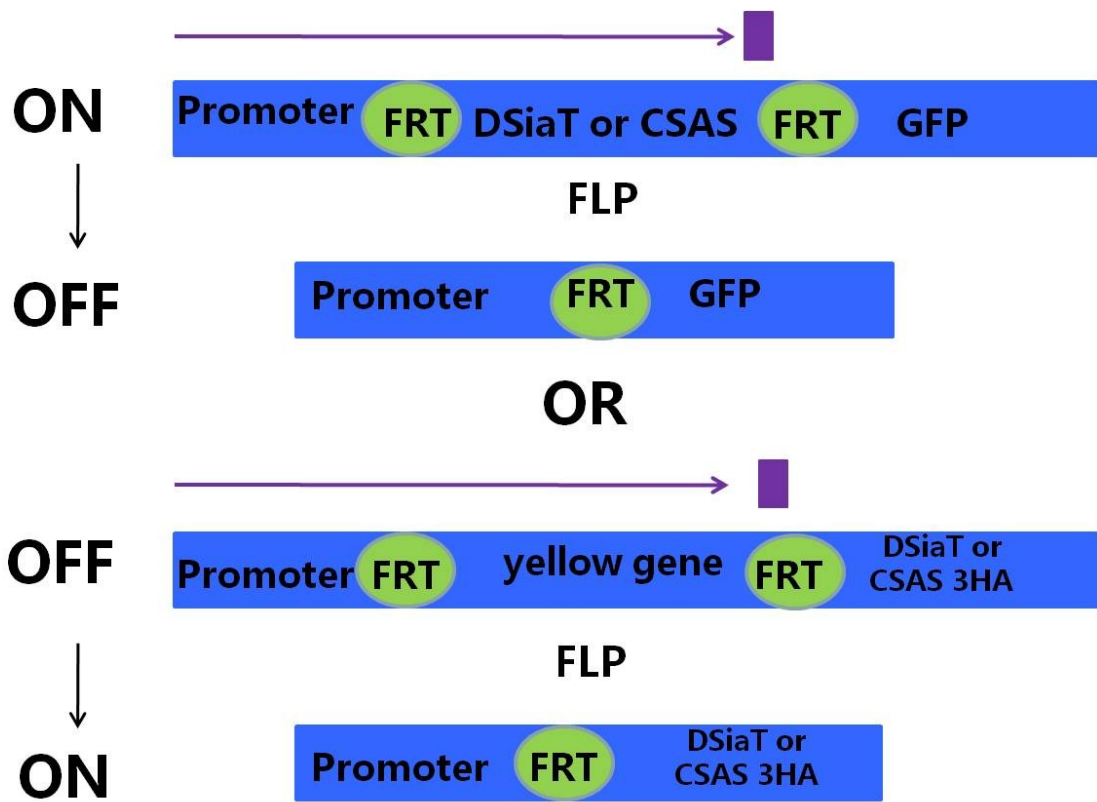

Figure 21. Schematic representation of the flip-out constructs.

VITA

MINDY NICOLE CARNAHAN

Address:

Department of Biochemistry/Biophysics, TAMU, College Station, TX,
77843-2128

Email Address:

altmyer2@gmail.com

Education:

B.S., Animal Sciences, University of Illinois at Urbana-Champaign, 2006
M.S., Genetics, Texas A&M University, 2011

Publications:

Carnahan M, Islam R, Nakamura M, Pandey D, Repnikova, E, Hardin P, Zoran MJ, Panin VM. 2011. Functional characterization of CMP sialic acid synthetase in *Drosophila*. In preparation.

Knox R, Taibl J, Altmyer M, Breen S, Canaday D, Visconti A.
“Assessment of follicle population changes in sows from day of weaning and during estrus using real-time ultrasound”. Society of Reproduction and Fertility Supplement 66: 199-200, 2009.

Academic Honors:

Dean’s List - undergraduate (5 semesters)
E.G. Mosbacher scholarship for merit and academic performance
C. & H. Musser scholarship for merit and academic performance
O.S. Carman scholarship for outstanding students in the college

Academic Associations:

Officer, Genetics Graduate Student Association at Texas A&M University
Member, Graduate Student Council at Texas A&M University
Member, Society of Glycobiology
Member, Tau Sigma Honor Society at University of Illinois