

**SYNTHETIC STRATEGIES TOWARD TETRAHYDROFURANS  
INVOLVING DOUBLE DIASTEREOSELECTIVE NUCLEOPHILE-  
PROMOTED ALDOL-LACTONIZATIONS AND SUBSEQUENT  
APPLICATIONS TO BIOACTIVE NATURAL PRODUCTS**

A Senior Scholars Thesis

by

KEVIN MICHAEL ARENDT

Submitted to the Office of Undergraduate Research  
Texas A&M University  
in partial fulfillment of the requirements for the designation as

UNDERGRADUATE RESEARCH SCHOLAR

April 2009

Major: Chemistry

**SYNTHETIC STRATEGIES TOWARD TETRAHYDROFURANS  
INVOLVING DOUBLE DIASTEREOSELECTIVE NUCLEOPHILE-  
PROMOTED ALDOL-LACTONIZATIONS AND SUBSEQUENT  
APPLICATIONS TO BIOACTIVE NATURAL PRODUCTS**

A Senior Scholars Thesis

by

KEVIN MICHAEL ARENDT

Submitted to the Office of Undergraduate Research  
Texas A&M University  
in partial fulfillment of the requirements for the designation as

UNDERGRADUATE RESEARCH SCHOLAR

Approved by:

Research Advisor:  
Associate Dean for Undergraduate Research:

Daniel Romo  
Robert C. Webb

April 2009

Major: Chemistry

## ABSTRACT

Synthetic Strategies Toward Tetrahydrofurans Involving Double Diastereoselective Nucleophile-Promoted Aldol-Lactonizations and Subsequent Applications to Bioactive Natural Product Synthesis. (April 2009)

Kevin Michael Arendt  
Department of Chemistry  
Texas A&M University

Research Advisor: Dr. Daniel Romo  
Department of Chemistry

Novel synthetic strategies towards the formation of tetrahydrofurans and their subsequent application to bioactive natural products have been explored. More specifically, a method for invoking double-diastereoselectivity in the formation of tetrahydrofuran-fused  $\beta$ -lactones through nucleophile-catalyzed aldol-lactonization (NCAL) has been developed. By employing a chiral catalyst, such as *OTMS*-quinidine or *OTMS*-quinine, coupled with a chiral aldehyde acid substrate, we have been able to successfully override the inherent substrate stereochemical bias to access either diastereomeric product as the major adduct. This new methodology is being applied to construction of the tetrahydrofuran fragment of the cytotoxic agent, haterumalide NA.

## **DEDICATION**

In memory of my beloved sister, Kathleen

## ACKNOWLEDGMENTS

Many thanks are in order for Dr. Romo for allowing me to join his research group and pursue my project. His devotion and passion for the science is what enticed me to pursue research in the lab. He was a supportive advisor who helped me work through the obstacles that I faced while doing research. I am also very grateful to him for sending me to the American Chemical Society National Meeting where I had the opportunity to present my research to the public.

A special acknowledgment goes to Ms. Kay Morris for mentoring me along my journey. All that I have learned and gained while in the lab has come from her insightful teaching. It is amazing to me to look back to when I first started and to see how far I have come in my understanding of chemistry thanks to you. Not only were you a great mentor, but you were, and always will be, a great friend. You gave me invaluable support through the difficult periods in the lab, and I could always count on your smile to cheer me up and help me continue through the often frustrating moments of research.

Of course, I could not be here without the support of my friends and family. They have stuck by me through it all, the good and the not-so-great, always with words of encouragement. I thank you, Mom and Dad, for believing in me; for believing that I was capable and competent enough to accomplish this great undertaking. Although, without the wonderful upbringing I received from you two, I do not think that I would be nearly

as fortunate as I am. All my accomplishments can in some way be drawn back to you and the great parenting you bestowed upon me. Thanks for just being loving parents, with a smile and a hug always waiting for me. Josh and Ryan, I could always count on you two for a laugh. Even though we may be miles apart, I can still sense your encouragement whenever I am faced with a difficult challenge.

Kathleen, you were my rock, my foundation, my core. I could lean on you and I knew that you would always be there for me in whatever I did. No matter what the situation, I always ended up having a great time with you. I guess the saying, “opposites attract” is true because there could not be any two people more different than you and I, yet we got along perfectly and had such a strong relationship that nothing could ever tear us apart. I miss you terribly but I know you are watching down on me and guiding my path. Though you may be gone, I will never lose that bond that you and I shared, that loving relationship that broke down barriers and helped me feel at peace with myself. I pursued this career path so that we could both live out our dreams, and now I do so in honor of you and your aspirations. With you in my heart always, I will continue down this path and strive to live life to its fullest, for the both of us.

**NOMENCLATURE**

9-BBN	9-borabicyclo[3.3.1]nonane
AcOH	Acetic Acid
amu	Atomic Mass Unit
CH <sub>2</sub> Cl <sub>2</sub>	Dichloromethane
cm <sup>-1</sup>	Wavenumber
DIBAL-H	Diisobutylaluminum Hydride
E <sub>1</sub> cb	Conjugate Base Elimination
Et <sub>2</sub> O	Diethyl Ether
EtOAc	Ethyl Acetate
H <sub>2</sub> SO <sub>4</sub>	Sulfuric Acid
Hex	Hexanes
Hz	Hertz
IR	Infrared
<i>J</i>	Coupling Constant
kcal	Kilocalorie
<i>m</i> -CPBA	<i>meta</i> -Chloroperoxybenzoic Acid
mmol	Millimoles
Na <sub>2</sub> SO <sub>4</sub>	Sodium Sulfate
NaHCO <sub>3</sub>	Sodium Bicarbonate
NaS <sub>2</sub> O <sub>3</sub>	Sodium Thiosulfate
NCAL	Nucleophile-Catalyzed Aldol-Lactonization

NH <sub>4</sub> Cl	Ammonium Chloride
NMR	Nuclear Magnetic Resonance
nOe	Nuclear Overhauser Effect
PPh <sub>3</sub>	Triphenylphosphine
ppm	Parts per Million
sat'd	Saturated
PPY	4-(pyrrolidin-1-yl)pyridine
TBDPS	<i>tert</i> -Butyldiphenylsilyl
THF	Tetrahydrofuran
<i>t</i> -Bu	<i>tert</i> -Butyl
TLC	Thin Layer Chromotography
<i>O</i> Ac-QD	Acetyl Quinidine
<i>OTMS</i> -QD	Trimethylsilyl Quinidine
<i>O</i> Ac-QN	Acetyl Quinine
<i>OTMS</i> -QN	Trimethylsilyl Quinine
μM	Micromolar
nM	Nanomolar



## TABLE OF CONTENTS

	Page
ABSTRACT .....	iii
DEDICATION .....	iv
ACKNOWLEDGMENTS.....	v
NOMENCLATURE.....	vii
TABLE OF CONTENTS .....	ix
LIST OF FIGURES.....	xi
LIST OF TABLES .....	xii
CHAPTER	
I    INTRODUCTION.....	1
Utility of $\beta$ -lactone functionality.....	1
Synthetic application towards natural products .....	4
An overview of the haterumalides .....	5
II    METHODS.....	9
General methods.....	9
III   RESULTS AND DISCUSSION .....	11
NCAL process.....	11
Initial studies .....	12
Hydrolytic kinetic resolution: A mechanistic study .....	14
Double-diastereoselective NCAL .....	15
NCAL optimization.....	18
IV    SUMMARY AND CONCLUSIONS.....	21
Ongoing studies.....	23
REFERENCES.....	25

	Page
APPENDIX I EXPERIMENTAL PROCEDURES .....	29
APPENDIX II SELECTED SPECTRAL DATA .....	40
CONTACT INFORMATION .....	64

## LIST OF FIGURES

FIGURE	Page
1.1 Natural products and precursors synthesized employing $\beta$ -lactone intermediates .....	2
1.2 Structural comparison of $\beta$ -lactones with epoxides and aldol products.....	3
1.3 Generic $\gamma$ -substituted tetrahydrofuran-fused $\beta$ -lactone .....	5
1.4 Structural and biological activity of the haterumalides.....	6
3.1 Illustration of accessibility of either enantiomer in high selectivity by employing chiral catalysts.....	12
3.2 Contrast between enantioselectivity and diastereoselectivity .....	16
3.3 Chiral nucleophiles studied in the NCAL process .....	19
4.1 Major byproducts formed in asymmetric NCAL reactions.....	21

**LIST OF TABLES**

TABLE	Page
1.1 Cytotoxicity of haterumalide NA methyl ester, cisplatin, adriamycin with IC <sub>50</sub> values (μM) .....	6
3.1 Theoretical outcome for NCAL reactions .....	17
3.2 Optimization results for double-diastereoselective NCAL process .....	20

# CHAPTER I

## INTRODUCTION

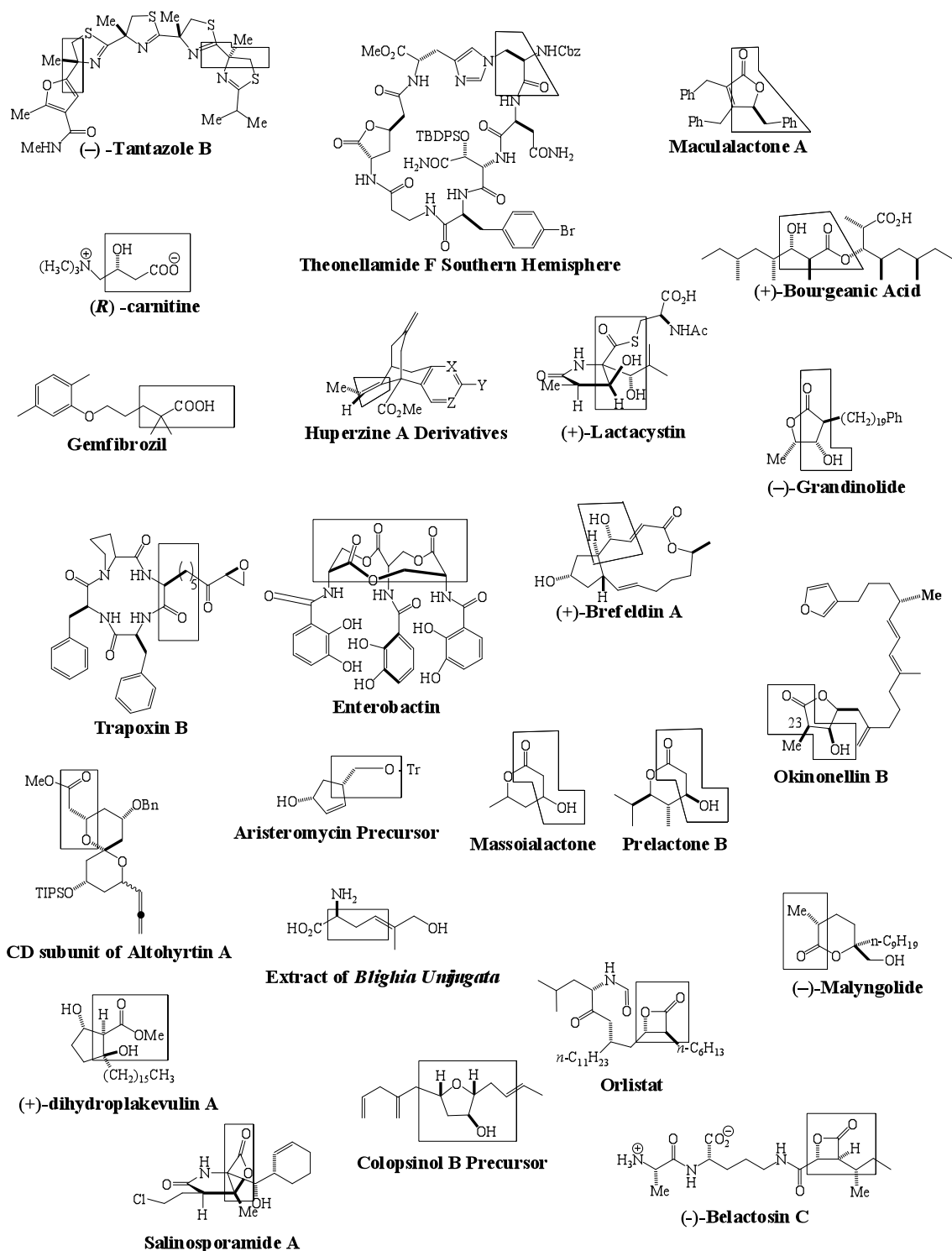
Chemistry is a dynamic science where new discoveries are constantly being made. This is especially true in synthetic organic chemistry as new reactions that produce a desired product in higher yield and with greater efficiency are sought. An area that has garnered considerable interest in the past half century is that of complex natural product total synthesis due to the great potential these compounds have as leads for drug discovery. Efficient synthesis of these intriguingly complex molecules is a great challenge to chemists world-wide. To address this problem, researchers have developed versatile synthetic intermediates, which can be easily manipulated into an array of functionalities. One such intermediate is the  $\beta$ -lactone (2-oxetanone) which is attracting growing interest for both synthesis and biology and is the focus of our research group.

### Utility of $\beta$ -lactone functionality

The  $\beta$ -lactone moiety has been shown quite successfully to be a useful intermediate in natural product total synthesis because it can easily be transformed into a number of different functionalities (Scheme 1.1).<sup>1</sup> There are many examples of natural product total syntheses in which  $\beta$ -lactones have been utilized as intermediates to facilitate the synthetic sequence (Figure 1.1). In the past, chemists have often used epoxides as synthetic intermediates because their inherent ring strain (27.8 kcal/mole) makes

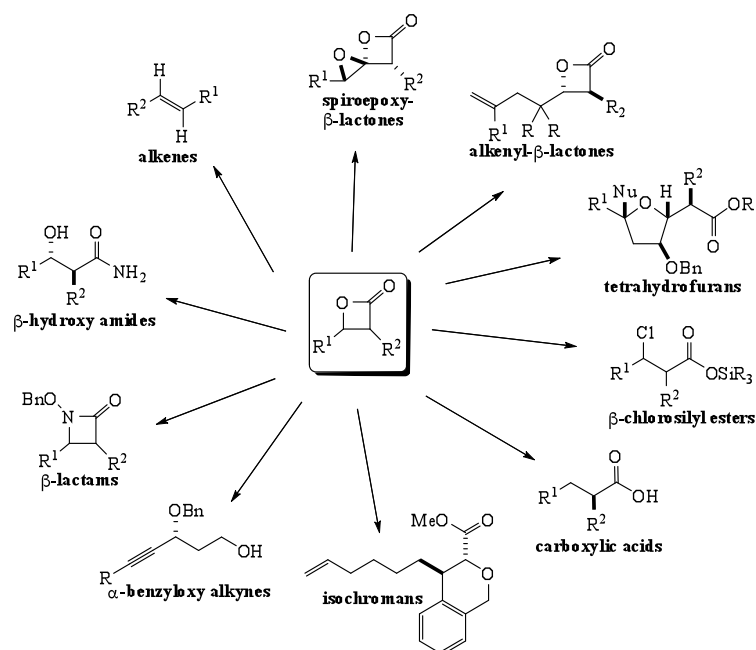
---

This thesis follows the style of *Journal of the American Chemical Society*.

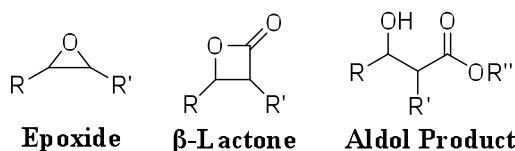


**Figure 1.1.** Natural products and precursors synthesized employing  $\beta$ -lactone intermediates (Atoms derived from the  $\beta$ -lactone are boxed).<sup>1-24</sup>

**Scheme 1.1.** Facile Transformations of  $\beta$ -Lactones.<sup>25</sup>



them reactive to a variety of reagents (Figure 1.2). However,  $\beta$ -lactones, while slightly less strained (22.8 kcal/mole), are structurally quite similar to aldol products. The combination of ring strain and structure allow  $\beta$ -lactones to undergo facile conversion in a stereospecific fashion. In addition,  $\beta$ -lactones are found in a number of enzyme inhibitors which suggests the possibility of developing cellular probes bearing this functionality to identify lead compounds as small molecule inhibitors of various cellular proteins important to human health and disease.<sup>26</sup>



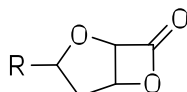
**Figure 1.2.** Structural comparison of  $\beta$ -lactones with epoxides and aldol products.

### **Synthetic application towards natural products**

Natural products, in the most general of definitions, are chemical compounds (typically <1500 amu) which are produced by living organisms. Many of these molecules possess bioactivity, and as a result have historically been excellent leads for novel drug discovery. A prime example is the isolation of the antibiotic penicillin from a fungus of the genus *Penicillium*.<sup>27</sup> Since its discovery several analogs possessing greater potency, such as ampicillin and methicillin, have been synthesized which are used to treat a variety of bacterial infections.<sup>28</sup> However, quantities of the compound that can be obtained from natural sources are often insufficient for further biological studies. To counter this imbalance, chemists continue to develop a number of strategies to synthesize natural products in the laboratory, ideally with increased efficiency. Often these natural products have multiple stereocenters which need to be synthesized with the correct stereochemical relationships, both relative and absolute, for the target molecule to maintain desired medicinal effects. Setting these stereocenters often involves multiple steps resulting in relatively low yields of the desired product. The low yield may be attributed to the lack of stereochemical control during the reactions producing a number of *enantiomers* or *diastereomers*, ultimately reducing the yield of the desired product. Thus chemists are constantly searching for new, more stereoselective synthetic strategies to obtain a particular enantiomer or diastereomer.<sup>29</sup> My current research involves developing a synthetic strategy that involves setting not only one but two stereocenters with high stereoselectivity, utilizing a *double diastereoselective* strategy.<sup>9</sup> Chemists have often used this strategy with various chiral catalysts to override the inherent



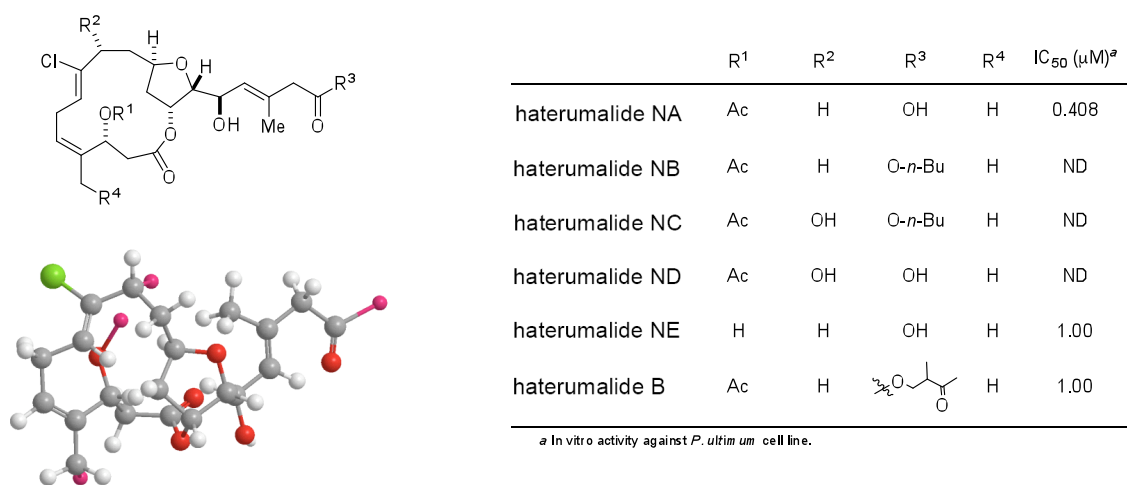
stereochemical bias of a chiral substrate to yield the desired stereoisomer.<sup>13,30</sup> With the aid of Dr. Daniel Romo and my mentor Kay Morris, I applied this strategy for the first time to the *Nucleophile-Catalyzed Aldol-Lactonization (NCAL)* reaction, a method developed in the Romo group,<sup>9</sup> to prepare tetrahydrofuran-fused  $\beta$ -lactones (Figure 1.3).



**Figure 1.3.** Generic  $\gamma$ -substituted tetrahydrofuran-fused  $\beta$ -lactone.

### **An overview of the haterumalides**

The haterumalides have been studied due to their interesting biological activity. Haterumalide B was first isolated by Ueda and Hu from the Okinawan ascidian *Lissoclinum spinosula*.<sup>31</sup> Initial assays showed that haterumalide B completely inhibited the cellular division of fertilized sea urchin eggs at a concentration of 18 nM.<sup>32</sup> Later studies revealed that this compound inhibits apothecial formation in fungi.<sup>31</sup> Around the same time Uemura *et. al.* isolated haterumalides NA, NB, NC, ND, and NE from a similar Okinawan sponge *Ircinia spinosula*.<sup>32</sup> Each haterumalide is a fourteen-membered, halogenated macrolide, containing a tetrahydrofuran (THF) ring (Figure 1.4). Many of the haterumalides act as antifungal agents and are able to completely suppress apothecial formation at concentrations ranging from 0.4-1.0  $\mu$ M.<sup>33-35</sup> However, the most potent member is haterumalide NA methyl ester.



**Figure 1.4.** Structure and biological activity of the haterumalides.

Table 1.1 compares the cytotoxicities of haterumalide NA methyl ester with two synthetic chemotherapy drugs.<sup>33</sup> Surprisingly, the natural product showed stronger potency to many of the cell lines, including human lung cancer NCI-H460, than the anticancer medications. This data encourages the use of the haterumalides as lead compounds in the development of novel anticancer drugs.

**Table 1.1.** Cytotoxicity of haterumalide NA methyl ester, cisplatin, and adriamycin with IC<sub>50</sub> values (μM)

	HOP18	NCI-H460	A498	PC-3	DLD-1	HCT116	P388	P388/ ADR
Haterumalide NA Methyl ester	0.739	0.135	0.335	0.539	0.141	0.292	0.408	0.621
Cisplatin	4.08	0.600	4.01	4.01	2.11	2.23	0.0754	0.271
Adriamycin	0.159	0.00823	0.166	0.357	0.910	0.0629	0.0253	5.79

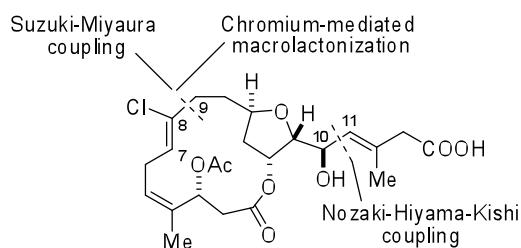
Interestingly the enantiomer of haterumalide NA (*ent*-haterumalide NA), derived from the soil bacterium *Serratia malcesens*, has been shown to decrease the formation of lipid droplets in adipocyte cells.<sup>36</sup> Elevated triglyceride levels in the blood stream decrease the efficiency of metabolism, ultimately giving rise to cardiovascular disease, diabetes,

obesity, and hypertension. Recent chemical genetic studies of *ent*-haterumalide have shown that this compound inhibits protein phosphatase 2A (PP2A).<sup>37</sup> PP2A regulates signal transduction cascades that produce vital biological events such as cell cycle transition and differentiation. Blocking PP2A inhibits preadipocytes from undergoing adipogenesis and maturing into triglyceride-containing adipocytes.<sup>37</sup> However, it is expected that haterumalide NA, as well as the other haterumalides, would have varying cellular receptors owing to their altered substitution and stereochemistry. Thus, our group is interested in the haterumalides as useful biological probes for further identification of novel receptors. Haterumalide NA is the main member of interest due to its unique structure, potent biological activity, and potential to uncover structure-activity relationships of derivatives with their targets.

The relative and absolute stereochemical assignments of haterumalide NA were originally determined by extensive 2D-nuclear magnetic resonance (NMR) experiments as well as studies of Mosher ester derivatives. The relative configuration of the tetrahydrofuran ring was acquired from nuclear Overhauser effect spectroscopy (nOe) correlations as well as by comparison to the structurally similar pectenotoxin<sup>38</sup> and isolaulimide.<sup>39</sup> However, later syntheses by both Kigoshi<sup>40</sup> and Snider<sup>41</sup> determined that all of the assignments, except for the C14 hydroxyl group, were inverted. Subsequent total synthesis by Hoye<sup>42</sup> confirmed the revised stereochemical assignments of haterumalide NA. Three other recent syntheses have focused on forming the C8-C9 bond in novel ways (Scheme 1.2). Kigoshi *et. al.* reported a second generation total

synthesis of haterumalide NA employing 9-BBN dimer in a Suzuki-Miyaura coupling and a nickel-catalyzed Nozaki-Hiyama-Kishi coupling as key steps in improving efficiency and yield of a common intermediate.<sup>43</sup> Borhan has also published a formal synthesis of haterumalide NA *via* an unprecedented chromium-mediated macrolactonization.<sup>44</sup> Roulland recently published a novel synthesis of haterumalide NA in which he uses a dichloro-olefin moiety to install the chlorine at C8 *via* a Suzuki-Miyaura coupling reaction.<sup>45</sup>

**Scheme 1.2.** Novel synthetic scheme for C8-C9 and C10-C11 bond formations of Haterumalide NA.



While these syntheses possess admirable qualities, the methodology which we have proposed would, in one step, create not only the THF ring setting three key stereocenters, but also a  $\beta$ -lactone which is 'spring-loaded' to undergo facile transformation to access the natural product haterumalide NA.

## CHAPTER II

### METHODS

#### General methods

All non-aqueous reactions were carried out under nitrogen atmosphere in oven-dried glassware (120 °C). Dichloromethane (CH<sub>2</sub>Cl<sub>2</sub>) and diethyl ether (Et<sub>2</sub>O) were obtained from a solvent purification system (alumina). Tetrahydrofuran (THF) was distilled from a sodium/benzophenone ketyl still. Triethyl amine (Et<sub>3</sub>N) and diisopropylethyl amine (*i*-Pr<sub>2</sub>NEt) were distilled from calcium hydride immediately prior to use. Deuterated solvents were purchased from either Aldrich or Cambridge Isotopes and used as received. All other chemicals were purchased from Aldrich or Acros and used without purification. Reactions were monitored by thin layer chromatography (TLC) on silica Merck 60 F<sub>254</sub> (0.25 mm). TLCs were stained using potassium permanganate and annisaldehyde stain. Flash column chromatography was carried out using silica (60 Å, 230-400 Mesh) as a stationary phase as described by Still.<sup>46</sup>

<sup>1</sup>H NMR characterization was performed on 300 MHz and 500 MHz spectrometers. <sup>13</sup>C NMR characterization was performed on 75 MHz and 125 MHz spectrometers. <sup>1</sup>H chemical shifts are reported as δ values in ppm relative to residual CHCl<sub>3</sub> (7.27 ppm). <sup>1</sup>H NMR coupling constants (*J*) are reported in Hertz (Hz), and multiplicities are indicated as follows: s (singlet), d (doublet), t (triplet), q (quartet), dd (doublet of

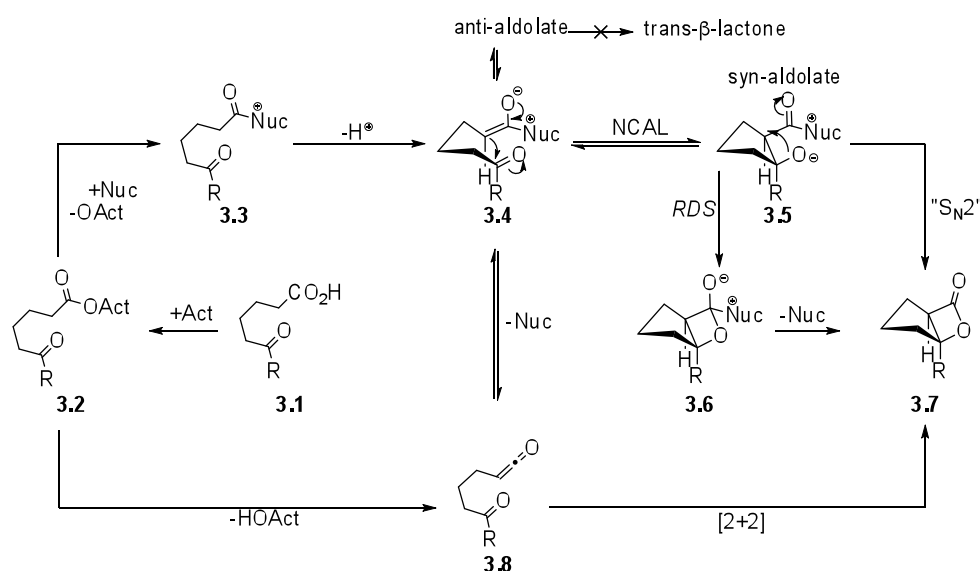
doublets), dt (doublet of triplets), dq (doublet of quartets), tt (triplet of triplets), m (multiplet), bs (broad singlet). Deuteriochloroform ( $\text{CDCl}_3$ ) served as internal standard (77.23 ppm) for all  $^{13}\text{C}$  spectra. Enantiomeric excess was calculated *via* HPLC analysis using a HPLC equipped with Chiralcel OD and Chiralpak IA columns. Infrared spectra were obtained as thin film on NaCl plates on a FTIR spectrometer. Vibrational frequencies are expressed in  $\text{cm}^{-1}$ . Mass spectra were obtained at the Laboratory for Biological Mass Spectrometry at Texas A&M University.

## CHAPTER III

### RESULTS AND DISCUSSION

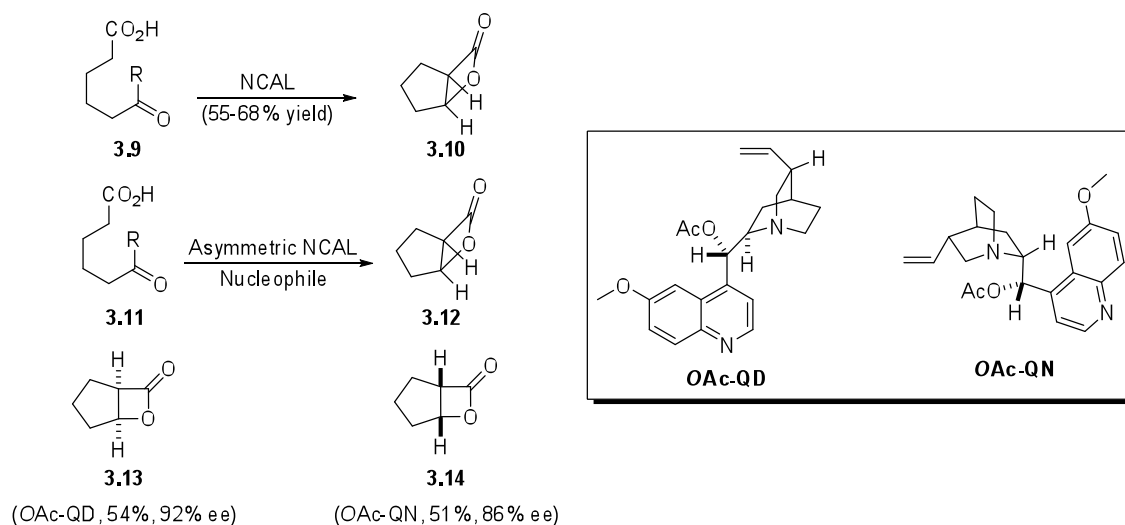
#### NCAL process

**Scheme 3.1.** Proposed Mechanism For Formation of Bicyclic  $\beta$ -Lactones.<sup>47</sup>



In the most general case, the intramolecular nucleophile-catalyzed aldol-lactonization (NCAL) process affords  $\beta$ -lactones fused to another cyclic moiety such as cyclopentane or a tetrahydrofuran. A thermal [2 +2] cycloaddition involving a ketene is plausible instead of the proposed NCAL pathway (Scheme 3.1).<sup>48</sup> Previous studies within our group have provided evidence in favor of a NCAL reaction over a [2 +2] cycloaddition since employing a chiral amine catalyst leads to the formation of bicyclic systems in high enantiomeric purity.<sup>9</sup> While the precise details of the NCAL process remains ambiguous and a competitive pathway could invoke ketene formation leading to a

reduction of enantiomeric purity, it is a minor pathway. Reaction through a ketene intermediate does not require involvement of the chiral nucleophile and therefore yields racemic  $\beta$ -lactones. However, addition of *OAc*-QD afforded bicyclic  $\beta$ -lactones in 92% enantiomeric excess; thereby providing support for an enantioselective NCAL pathway. Optimization of the conditions used, namely employing Mukaiyama's reagent as an activating agent coupled with *OAc*-QD acting as a chiral nucleophile along with achiral Hünig's base, ultimately led to the formation of  $\beta$ -lactones with excellent enantioselectivity (98%).<sup>30</sup> The  $\beta$ -lactone was formed with similar but reversed levels of asymmetric induction by using the pseudo-enantiomer *OAc*-QN as the chiral nucleophile (Figure 3.1).



**Figure 3.1.** Illustration of accessibility of either enantiomer in high selectivity by employing chiral catalysts.

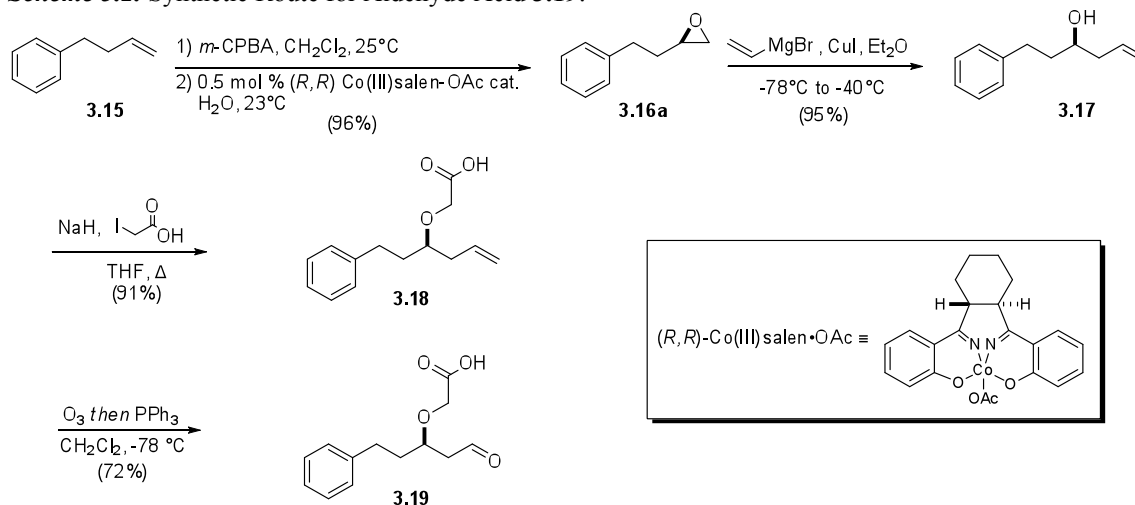
### Initial studies

Herein, we report the development of a methodology for the synthesis of tetrahydrofuran-fused  $\beta$ -lactones *via* a novel double-diastereoselective NCAL process.



The required aldehyde acid precursor **3.19** was prepared by a five step sequence starting with commercially available 4-phenyl-1-butene (Scheme 3.2). The alkene was first reacted with *meta*-chloroperoxybenzoic acid (*m*-CPBA) to form racemic epoxides **3.15a/3.15b**; which were subsequently subjected to Jacobsen's hydrolytic kinetic resolution to afford the desired epoxide **3.15a**. Ring-opening with vinyl magnesiumbromide followed by addition of iodoacetic acid gave alkene-acid **3.18**. Oxidation *via* ozonolysis in conjunction with a reductive work-up led to aldehyde acid **3.19**.

**Scheme 3.2.** Synthetic Route for Aldehyde Acid **3.19**.



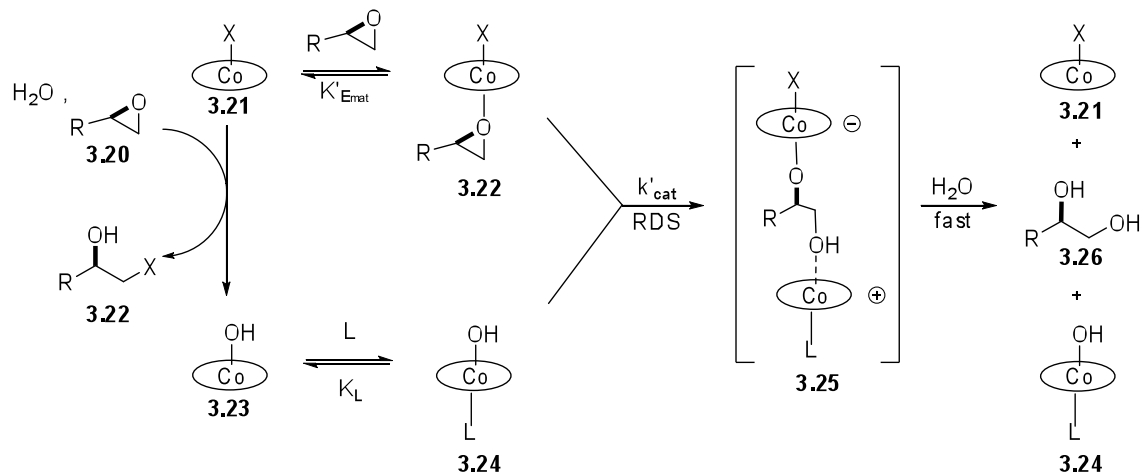
The reactions proceeded smoothly with the assumption that high enantioselectivity was achieved in the hydrolytic kinetic resolution step. However, once we began initial studies towards  $\beta$ -lactone formation it was discovered that aldehyde acid precursor **3.18** was in fact a racemic mixture. The low enantioselectivity observed was due to the second step in the sequence, specifically the hydrolytic-kinetic resolution step, affording

little to no resolution of the two enantiomers **3.16a/3.16b**. A closer inspection of Jacobsen's mechanism for hydrolytic-kinetic resolution provided insight to solve this problem.

### Hydrolytic kinetic resolution: A mechanistic study

The basis for hydrolytic kinetic resolution is that one enantiomer of the epoxide reacts preferentially to the other enantiomer *via* ring-opening with water to resultant diol. This reaction is catalyzed by a Co(III)-salen catalyst and has been found to proceed through a bimetallic mechanism similar to other asymmetric ring-opening reactions (Scheme 3.3).<sup>49</sup>

**Scheme 3.3.** Dominant Catalytic Cycle in HKR Reactions Catalyzed by Co-X (X ≠ OH).



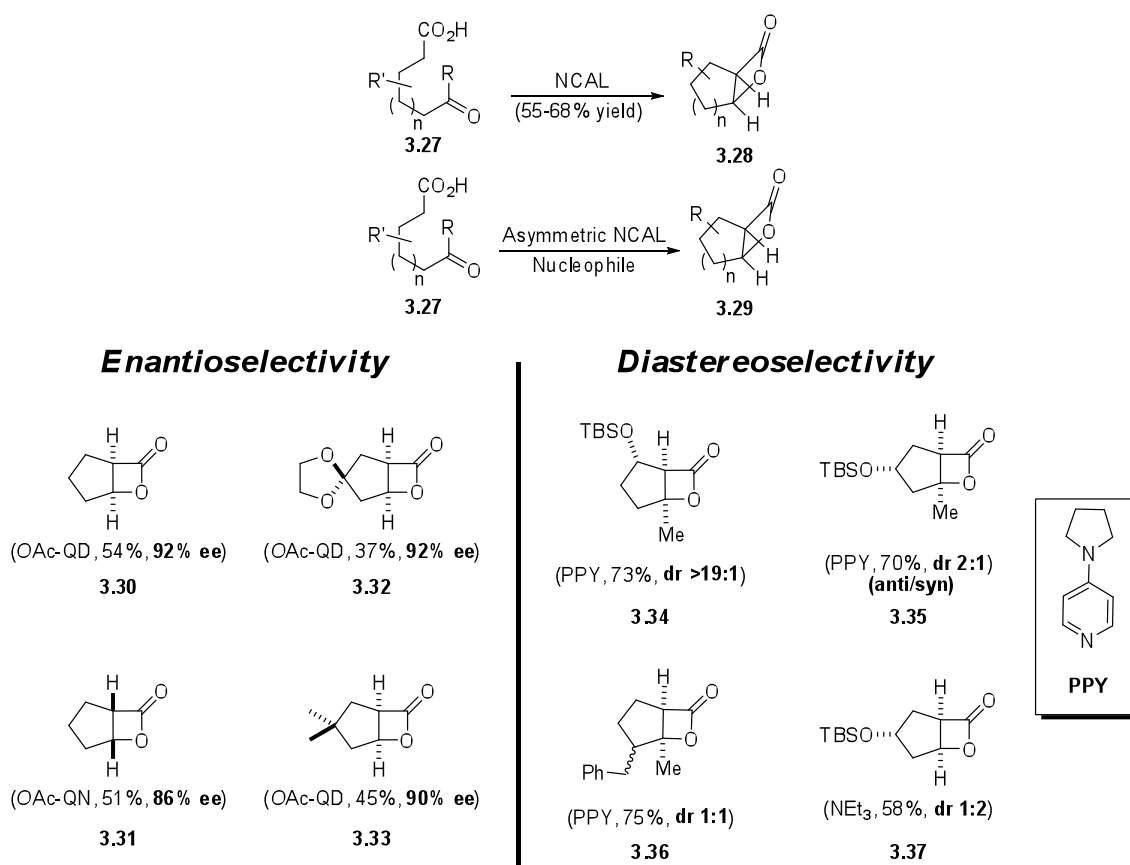
Jacobsen found that the catalyst equally bound to either enantiomer of the epoxide and after detailed studies concluded that the high selectivity observed in hydrolytic kinetic resolution results from a counter-ion effect. The initial rate at which the counter-ion of

the catalyst is displaced with water influences the rate of the reaction and ultimately the selectivity. Since the reaction proceeds through coordination of the epoxide to the Lewis acidic cobalt ( $X \neq \text{OH}$ ) the Lewis basic cobalt species ( $X = \text{OH}$ ) is the rate determining step as well as the stereochemical setting step. A balance for production of each cobalt species is the key to high enantioselectivity for this reaction. If the initial addition of the counter-anion to the epoxide is either too slow or too fast the reaction will proceed at a low rate, as in our previous results. The fastest rates can be achieved when a balance for counter-anion addition is obtained. Thus, faster addition of water provided this balance and led to maximum resolution rates giving high enantiomeric ratios (16:1  $\rightarrow$  99:1 er) of the unreacted epoxide and corresponding diol products.

### **Double-diastereoselective NCAL**

Use of *OAc-QD* or *OAc-QN* gave similar levels of enantio-enrichment but with reversal in the absolute stereochemistry. This asymmetric NCAL process was amenable to a variety of carbocyclic, bicyclic  $\beta$ -lactones, which provided a promising starting point for further application toward a double-diastereoselective process. Substitution at the  $\beta$ -position led to >19:1 diastereoselectivity (Figure 3.2). However,  $\gamma$ - or  $\delta$ -substituents gave bicyclic products with little to no diastereoselectivity. Although low diastereoselectivities were obtained with  $\gamma$ - or  $\delta$ -substitution, the high enantioselectivity observed in the previous NCAL studies prompted the pursuit of double-diastereoselective NCAL methodology.

The hypothesis was that by using one enantiomer of the substrate obtained prior to subjecting to the NCAL, two isomeric products would be eliminated. The asymmetric nucleophile would then control the stereochemistry at the fused positions in the bicyclic system while also overcoming the inherent bias exhibited by the substrate (Scheme 3.4).



**Figure 3.2.** Contrast between enantioselectivity and diastereoselectivity. Relative diastereoselection for carbocycle-fused  $\beta$ -lactones bearing  $\beta$ -,  $\gamma$ -, and  $\delta$ -substitution.

In 1985 Sharpless defined the concept of using a chiral catalyst to override the inherent stereochemical bias of the substrate, leading to a so-called “mismatched” case which has been practiced by several chemists, primarily Masamune.<sup>29</sup> Similarly, a different

catalyst can be employed which displays the same selectivity as the substrate, thereby making a “matched” case.

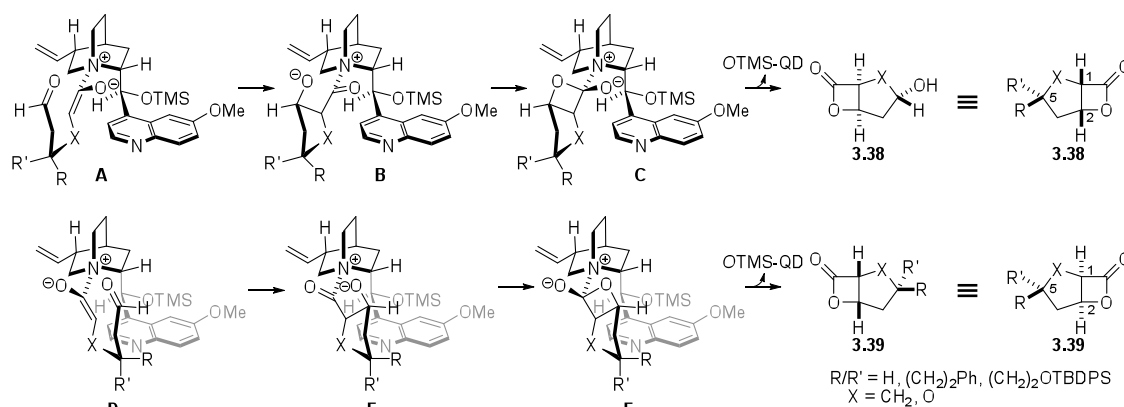
As previously shown, high enantioselectivity can be achieved during the NCAL process with an optically active catalyst (Figure 3.1). Theoretically, utilizing a single enantiomer of the aldehyde acid should provide *both* high enantioselectivity as well as high diastereoselectivity. The use of racemic or achiral reactants leads to a variety of

**Table 3.1.** Theoretical outcome for NCAL reactions

Aldehyde Acid	Nucleophile	Product ee	Product dr
Racemic	Achiral	Low ee	Low dr
Optically active	Achiral	High ee	Low dr
Racemic	Chiral	High ee	Low dr
<b>Optically active</b>	<b>Chiral</b>	<b>High ee</b>	<b>High dr</b>

expected stereochemical results, which are outlined in Table 3.1. Based on these predictions, we began screening a variety of conditions for the NCAL reaction that would lead to the desired enantio- and diastereoselectivity.

**Scheme 3.4.** Rationale for OTMS-QD control of enantioselectivity at fused carbons.

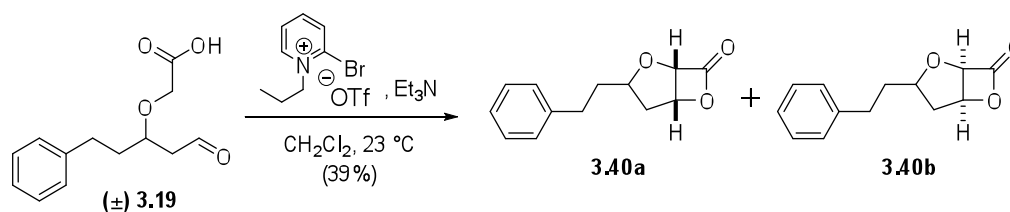


The enantioselectivity can be explained by catalyst conformation shown above. In the scheme presented above, *OTMS-QD* directs the aldehyde acid to react in a conformation that positions the substrate further away from the bulky aryl group as well as reducing unfavorable electronic interactions between the ammonium enolate and the aromatic system. This results in carbocycle- or tetrahydrofuran-fused  $\beta$ -lactone **3.38** with the *trans* relative configuration for all three stereocenters; and the absolute stereochemistry being (1*S*,2*R*,5*S*). The pseudo-enantiomer of *OTMS-QD*, *OTMS-QN*, directs the formation of the ammonium enolate in a similar fashion; however, the absolute stereochemical outcome of bicyclic  $\beta$ -lactone **3.39** is reversed to provide the (1*R*,2*S*,5*S*), with the *cis*-diastereomer favored.

### NCAL optimization

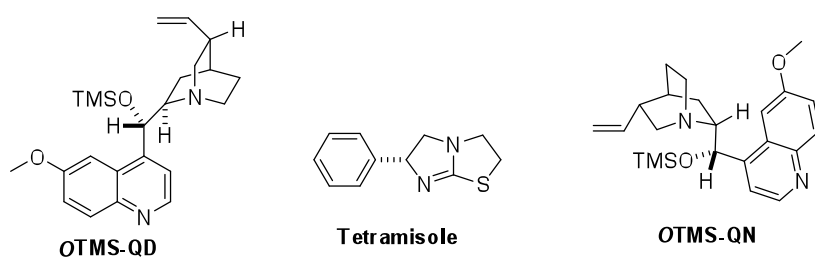
With both racemic and optically active aldehyde acid **3.19** in hand, we began to investigate a variety of conditions to facilitate a double-diastereoselective nucleophile-catalyzed aldol-lactonization process. To observe the substrate's inherent stereochemical bias a control experiment was run by adding racemic aldehyde acid **3.19** to Mukaiyama's reagent and triethyl amine, the latter reagent acted as both a base and an achiral nucleophile (Scheme 3.5).

**Scheme 3.5.** Double-Diastereoselective Nucleophile-Catalyzed Aldol-Lactonization.



The reaction afforded tetrahydrofuran-fused  $\beta$ -lactones **3.40a/3.408b** in moderate yield (39%) with a slight preference for the *trans*-bicyclic system **3.40a** with a diastereomeric ratio of 2:1. Based on earlier research involving carbocycle-fused  $\beta$ -lactones, in which both good enantioselectivity and diastereoselectivity could be achieved, we chose to employ *OTMS-QN* and *OTMS-QD* to act as chiral nucleophiles (Figure 3.3)<sup>30</sup>, while changing the base to an achiral amine *i*-Pr<sub>2</sub>NEt.

However, the results obtained from our experiments revealed that oxygenated systems behave and react differently than their all carbon analogs.



**Figure 3.3.** Chiral nucleophiles studied in the NCAL process.

Using the same conditions as previously reported for carbocycles, the NCAL process afforded tetrahydrofuran-fused  $\beta$ -lactones in poor yield (Table 3.2). Even more intriguing was the fact that the chiral cinchona alkaloid catalysts employed in these experiments displayed little to no diastereoselectivity for the desired bicyclic systems. An attempt at optimization using the quinidine and quinine derived nucleophiles with varying reaction times showed no improvement in  $\beta$ -lactone yield or in diastereoselectivity.

Entry 4 does show that the OTMS-QD provided catalyst control to a certain extent; however, the overall tetrahydrofuran-fused  $\beta$ -lactone yield was still too low to be considered a practical process.

**Table 3.2.** Optimization results for double-diastereoselective NCAL process

**3.19** R = (CH<sub>2</sub>)<sub>2</sub>Ph  
**3.41** R = (CH<sub>2</sub>)<sub>2</sub>OTBDPS

entry <sup>a</sup>	s.m.	nucleophile (equiv.)	base	time (h)	dr( <b>a:b</b> ) <sup>b</sup>	% yield
1	<b>3.19</b>	NEt <sub>3</sub> (1.0)	NEt <sub>3</sub>	2	1:1	37
2 <sup>c</sup>	<b>3.19</b>	OTMS-QD (0.1)	( <i>i</i> -Pr) <sub>2</sub> NEt	48	4:1	40
3 <sup>c</sup>	<b>3.19</b>	OTMS-QN (0.1)	( <i>i</i> -Pr) <sub>2</sub> NEt	48	1.5:1	35
4	<b>3.19</b>	OTMS-QD (0.1)	( <i>i</i> -Pr) <sub>2</sub> NEt	24	5.2:1	12
5	<b>3.19</b>	OTMS-QN (0.1)	( <i>i</i> -Pr) <sub>2</sub> NEt	24	1:1	15
6 <sup>c,d</sup>	<b>3.41</b>	Tetramisole (1.0)	( <i>i</i> -Pr) <sub>2</sub> NEt	18	1:1	6
7 <sup>d</sup>	<b>3.41</b>	Tetramisole (0.1)	( <i>i</i> -Pr) <sub>2</sub> NEt	18	1:1 <sup>e</sup>	13

<sup>a</sup> All reactions were carried out with 4 equiv. base at 0.2 M. <sup>b</sup> Determined by crude <sup>1</sup>H NMR. <sup>c</sup> Racemic starting material. <sup>d</sup> Reaction carried out with 2.2 equiv. base at 0.05 M. <sup>e</sup> 86-99% ee by chiral HPLC.

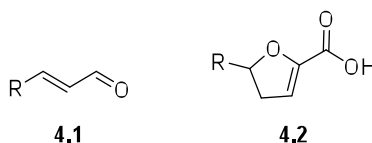
Changing the substituent on the aldehyde acid to a protected alcohol as well as utilizing the more nucleophilic catalyst tetramisole led to a significant decrease in tetrahydrofuran-fused  $\beta$ -lactone (entry 6).<sup>50</sup> Further optimization is required for this reaction to achieve the high double-diastereoselectivity and higher yields are needed for a practical synthetic methodology.



## CHAPTER IV

### SUMMARY AND CONCLUSIONS

We have shown that a double-diastereoselective bis-cyclization can be afforded employing the nucleophile-catalyzed aldol-lactonization process with both chiral substrates and chiral nucleophiles (Lewis bases). Previously, several  $\beta$ -lactone-fused carbocycles have been formed in good yield with high diastereomeric ratios; however, certain substituted substrates e.g.  $\delta$ -substituted aldehyde acids led to low diastereoselectivity. Tetrahydrofuran-fused  $\beta$ -lactones have been formed *via* this double-diastereoselective NCAL process; however, the yields are low and the reactions provide little to no diastereoselectivity. The major byproducts of these reactions are  $\alpha,\beta$ -unsaturated aldehyde **4.1** as well as  $\alpha,\beta$ -unsaturated acid **4.2** (Figure 4.1).

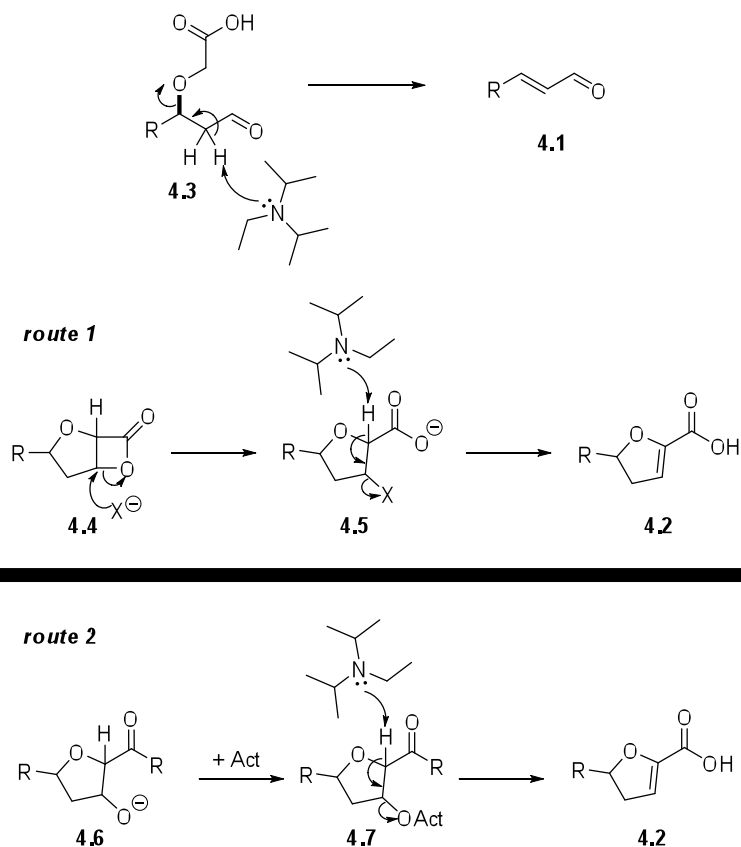


**Figure 4.1.** Major byproducts formed in asymmetric NCAL reactions.

This result was not observed in the carbocyclic systems because the substrate did not possess a heteroatom and therefore less prone to  $\beta$ -elimination or condensation. For the tetrahydrofuran systems however, the oxygen at the  $\gamma$ -position in the aldehyde acid pulls electron density away from the carbons at the  $\alpha$ - and  $\beta$ -positions, thus causing the  $\beta$ -protons to become more acidic and therefore more susceptible to  $\beta$ -elimination due to excess base (Scheme 4.1). In a similar manner,  $\alpha,\beta$ -unsaturated acid **4.2** is formed by

ring-opening and subsequent elimination of the product  $\beta$ -lactone or through an aldol condensation process.

**Scheme 4.1.** Mechanistic rationale for formation of byproducts in the NCAL process ( $X = \text{OAc}$ ,  $\text{OTMS}$ ). Two possible routes for the formation of **4.2** can be envisioned. Note that elimination processes for both **4.1** and **4.2** could proceed via  $\text{E}_{1\text{cb}}$  mechanisms (not shown).

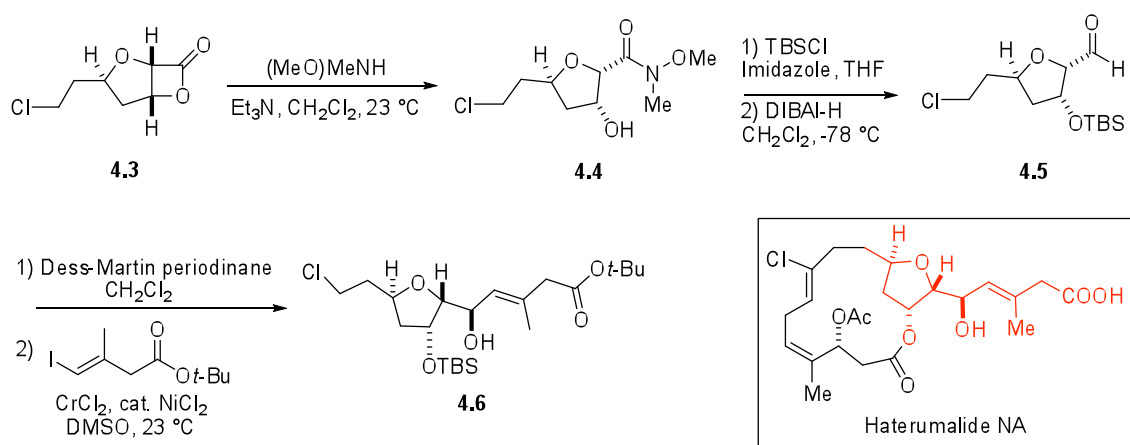


Basic conditions are required to activate the aldehyde acid substrate employed in the NCAL reaction. Due to the oxygenated substrate's ability to undergo facile  $\beta$ -elimination, perhaps a bulkier base could be employed that would be basic enough to activate the aldehyde acid yet too sterically hindered to access protons available for  $\beta$ -elimination.

## Ongoing studies

Continuing investigations into finding optimal conditions for a double-diastereoselective NCAL process employing oxygenated substrates is currently being pursued. Once sufficient optimization is achieved, the synthesis of the side chain of haterumalide NA will commence. The proposed synthetic route is outlined in Scheme 4.2. Diastereomerically pure tetrahydrofuran-fused  $\beta$ -lactone **4.3** will be treated with *N*, *O*-dimethylhydroxylamine to form Weinreb amide **4.4**. Protection of the free alcohol with *tert*-butyldimethylsilyl chloride followed by reduction of the amide with DIBAL-H would afford aldehyde **4.5**. Treatment with Dess-Martin periodinane and subsequent Nozaki-Hiyama-Kishi coupling of a vinyl iodine species would ultimately lead to tetrahydrofuran fragments with high diastereoselectivity for the desired diastereomers, i.e. **4.6**.<sup>40</sup>

**Scheme 4.2.** Proposed synthetic route towards THF fragment of haterumalide NA.



Preparation of the tri-substituted tetrahydrofuran **4.6** via the NCAL process constitutes an innovative synthetic route to the eastern hemisphere of haterumalide NA. Further

manipulation of the THF ring and subsequent macrolactonization would ultimately lead to the natural product. Application of the double-diastereoselective NCAL reaction in the synthesis of haterumalide NA leads enables setting of several required stereocenters with great efficiency; thereby eliminating the need for late-stage reactions to establish the desired stereochemistry, which would lead to a less efficient and lower yielding synthesis.

## REFERENCES

- (1) Wang, Y.; Tennyson, R. L.; Romo, D. *Heterocycles* **2004**, *64*, 605-658.
- (2) Fukuyama, T.; Xu, L. *J. Am. Chem. Soc.* **1993**, *115*, 8449-8450.
- (3) Tohdo, K.; Hamada, Y.; Shioiri, T. *Synlett* **1994**, 247-249.
- (4) White, J. D.; Johnson, A. T. *J. Org. Chem.* **1994**, *59*, 3347-3358.
- (5) Zemribo, R.; Champ, M. S.; Romo, D. *Synlett* **1996**, 278-280.
- (6) Schmitz, W. D.; Messerschmidt, N. B.; Romo, D. *J. Org. Chem.* **1998**, *63*, 2058-2059.
- (7) Tennyson, R. L.; Cortez, G. S.; Galicia, H. J.; Kreiman, C. R.; Thompson, C. M.; Romo, D. *Org. Lett.* **2002**, *4*, 533-536.
- (8) Wang, Y.; Romo, D. *Org. Lett.* **2002**, *4*, 3231-3234.
- (9) Cortez, G. S.; Tennyson, R. L.; Romo, D. *J. Am. Chem. Soc.* **2001**, *123*, 7945-7946.
- (10) Corey, E. J.; Reichard, G. A.; Kania, R. *Tetrahedron Lett.* **1993**, *34*, 6977-6980.
- (11) Song, C. E.; Lee, S. H.; Lee, J. K.; Lee, S.-G. *Tetrahedron: Asymmetry* **1995**, *6*, 1063-1066.
- (12) Martinez, E. R.; Salmassian, E. K.; Lau, T. T.; Guitierrez, C. G. *J. Org. Chem.* **1996**, *61*, 3548-3550.
- (13) Schneider, C. *Angew. Chem. Int. Ed.* **2002**, *41*, 744-746.

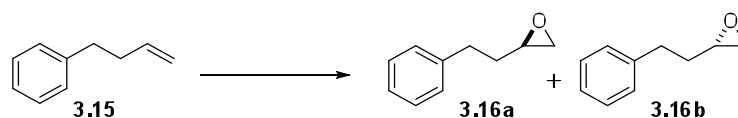
- (14) Kozikowski, A. P.; Campiani, G.; Nacci, V.; Segal, A.; Saxena, A.; Doctor, B. P. *J. Chem. Soc. Perkin Trans. I* **1996**, *11*, 1287-1297.
- (15) Zemribo, R.; Mead, K. T. *Synlett* **2000**, 1569-1572.
- (16) Calter, M. A.; Liao, W. *J. Am. Chem. Soc.* **2002**, *124*, 13127-13129.
- (17) Calter, M. A.; Liao, W.; Struss, J. A. *J. Org. Chem.* **2001**, *66*, 7500-7504.
- (18) Nelson, S. G.; Cheung, W. S.; Kassick, A. J.; Hilfike, M. A. *J. Am. Chem. Soc.* **2002**, *124*, 13654-13655.
- (19) Wan, Z.; Nelson, S. G. *J. Am. Chem. Soc.* **2000**, *122*, 10470-10471.
- (20) Fournier, L.; Gaudel-Siri, A.; Kocienski, P. J.; Pons, J.-M. *Synlett* **2003**, 107-111.
- (21) Mitchell, A. T., Texas A&M University, 2008, *Development of a Tandem, Three-Component Synthesis of Tetrahydrofurans via Silylated  $\beta$ -Lactone Intermediates in the Tandem Mukaiyama Aldol-Lactonization*, Ph.D. dissertation.
- (22) Brown, G. D.; Wong, H.-F. *Tetrahedron* **2004**, *60*, 5439-5451.
- (23) Ma, G.; Nguyen, H.; Romo, D. *Org. Lett.* **2007**, *9*, 2143-2146.
- (24) Ma, G.; Zancanella, M.; Oyola, Y.; Richardson, R. D.; Smith, J. W.; Romo, D. *Org. Lett.* **2006**, *8*, 4497-4500.
- (25) Yang, H. W.; Romo, D. *Tetrahedron* **1999**, *55*, 6403-6434.
- (26) Peddibhotla, S.; Dang, Y.; Liu, J. O.; Romo, D. *J. Am. Chem. Soc.* **2007**, *129*, 12222-12231.
- (27) Fleming, A. B. *J. Exp. Pathol.* **1929**, *10*, 226-236.

- (28) Esplin, B.; Théorêt, Y.; Seward, E.; Capek, R. *Neuropharmacology* **1985**, *24*, 571-575.
- (29) Sharpless, K. B. *Chemica Scripta* **1985**, *25*, 71-77.
- (30) Oh, S. H.; Cortez, G. S.; Romo, D. *J. Org. Chem.* **2005**, *70*, 2835-2838.
- (31) Ueda, K.; Yumin, H. *Tetrahedron Lett.* **1999**, *40*, 6305-6308.
- (32) Takada, N.; Sato, H.; Kiyotake, S.; Arimoto, H.; Yamada, K.; Ueda, K.; Uemura, D. *Tetrahedron Lett.* **1999**, *40*, 6309-6312.
- (33) Teruya, T.; Suenaga, K.; Maruyama, S.; Mineko, K.; Kigoshi, H. *Tetrahedron* **2005**, *61*, 6561-6567.
- (34) Levenfors, J. J.; Hedman, R.; Thaning, C.; Gerhardson, B.; Welch, C. J. *Soil Biol. Biochem.* **2004**, *36*, 677-685.
- (35) Kigoshi, H.; Hayakawa, I. *Chem Rec* **2007**, *7*, 254-264.
- (36) Sato, B.; Nakajima, H.; Fujita, T.; Takase, S.; Yoshimura, S.; Kinoshita, T.; Terano, H. *J. Antibiot.* **2005**, *58*, 634-639.
- (37) Yamaoka, M.; Sato, K.; Kobayashi, M.; Nishio, N.; Ohkubo, M.; Fujii, T.; Nakajima, H. *J. Antibiot.* **2005**, *58*, 654-662.
- (38) Murata, M.; Sano, M.; Iwashita, T.; Naoki, H.; Yasumoto, T. *Agric. Biol. Chem.* **1986**, *50*, 2693-2695.
- (39) Jefford, C. W.; Bernardinelli, G.; Tanaka, J.-i.; Higa, T. *Tetrahedron Lett.* **1996**, *37*, 159-162.
- (40) Kigoshi, H.; Kita, M.; Ogawa, S.; Itoh, M.; Uemura, D. *Org. Lett.* **2003**, *5*, 957-960.

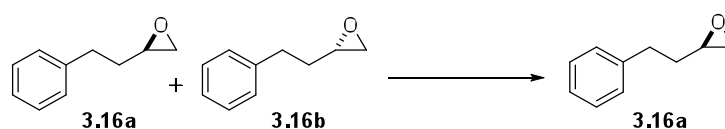
- (41) Gu, Y.; Snider, B. B. *Org. Lett.* **2003**, *5*, 4385-4388.
- (42) Hoye, T. R.; Wang, J. *J. Am. Chem. Soc.* **2005**, *127*, 6950-6951.
- (43) Hayakawa, I.; Ueda, M.; Yamaura, M.; Ikeda, Y.; Suzuki, Y.; Yoshizato, K.; Kigoshi, H. *Org. Lett.* **2008**, *10*, 1859-1862.
- (44) Schomaker, J. M.; Borhan, B. *J. Am. Chem. Soc.* **2008**, *130*, 12228-12229.
- (45) Roulland, E. *ChemInform* **2008**, *39*, 3822-3825.
- (46) Still, W. C.; Kahn, M.; Mitra, A. *J. Org. Chem.* **1978**, *43*, 2923-2925.
- (47) Cortez, G. S.; Oh, S. H.; Romo, D. *Synthesis* **2001**, 1731-1736.
- (48) Brady, W. T.; Giang, Y. F. *J. Org. Chem.* **1986**, *51*, 2145-2147.
- (49) Nielsen, L. P. C.; Stevenson, C. P.; Blackmond, D. G.; Jacobsen, E. N. *J. Am. Chem. Soc.* **2004**, *126*, 1360-1362.
- (50) Birman, V. B.; Li, X. *Org. Lett.* **2006**, *8*, 1351-1354.



**APPENDIX I**  
**EXPERIMENTAL PROCEDURES**

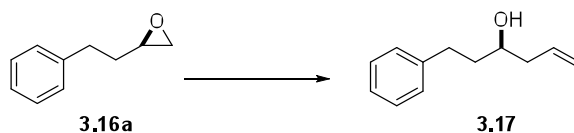


**(R/S)-2-Phenethyloxirane (3.16a/3.16b).** To a 150 mL flask containing *m*-chloroperoxybenzoic acid, 70% solution in water (17.7 g, 71.8 mmol) and CH<sub>2</sub>Cl<sub>2</sub> (50 mL) was added 4-phenyl-1-butene **3.15** (7.19 g, 8.17 mL, 54.4 mmol). The solution was cooled to 0 °C and allowed to warm to 23 °C over 12 h. The reaction mixture was filtered through a fritted funnel and the solids washed with sat'd NaS<sub>2</sub>O<sub>3</sub> (5 mL). The organic layer was washed with H<sub>2</sub>O (2 X 15 mL) and sat'd NaCl (10 mL). The combined organics were dried over Na<sub>2</sub>SO<sub>4</sub> and concentrated *in vacuo*. The crude material was then purified by flash column chromatography (1:9 EtOAc:Hexanes) to yield racemic epoxide **3.16a/3.16b** (7.73 g, 96%) as a colorless oil.  $R_f = 0.33$  (EtOAc:Hexanes = 1:9); <sup>1</sup>H NMR (500 MHz, CDCl<sub>3</sub>) δ 7.34-7.21 (m, 5H), 2.99-2.95 (m, 1H), 2.79 (dd, *J* = 3.0 Hz, 2H), 2.74 (dt, 4.0, *J* = 1.0 Hz, 1H), 2.46 (q, *J* = 2.7 Hz, 1H), 1.90-1.82 (m, 2H); <sup>13</sup>C NMR (125 MHz, CDCl<sub>3</sub>) δ 141.5, 128.6, 128.5, 126.2, 52.0, 47.5, 34.5, 32.5.



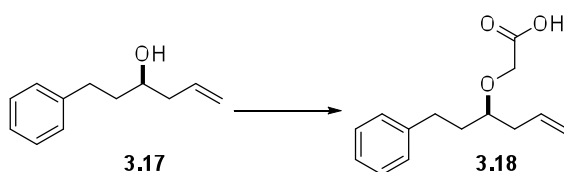
**(R) 2-Phenethyloxirane (3.16a).** To a 10 dram vial was added a mixture of (*R,R*)-(-)-*N,N'*-Bis(3,5-di-*tert*-butylsalicylidene)-1,2-cyclohexanediaminocobalt(II) catalyst (44.5 mg, 0.067 mmol, 0.005 mmol), toluene (1.0 mL), and acetic acid (0.026 mL, 0.027 mg).

The reaction mixture was stirred open to the air for 30 min. at 23 °C then concentrated *in vacuo*. To the red-brown residue was added (*R/S*) epoxide **3.16a/3.16b** (2.00 g, 13.5 mmol) and the solution cooled to 0 °C. H<sub>2</sub>O (0.134 mL, 7.43 mmol) was added to the vial over 5 min. *via* syringe pump. The reaction mixture was stirred for an additional 18 h. The oily, brown liquid was diluted with CH<sub>2</sub>Cl<sub>2</sub> and dried over MgSO<sub>4</sub> and concentrated *in vacuo*. The resulting crude oil was purified by flash column chromatography (1:7 EtOAc:Hexanes) to yield epoxide **3.16a** (0.880 g, 44%, 88% based on 50% max) as a red-orange oil.  $R_f = 0.39$  (EtOAc:Hexanes = 1:19); Determination of enantiomeric excess *via* chiral HPLC. Analysis of ( $\pm$ )-2-Phenethyloxirane **3.16**: Chiralcel OD97.54.5 column, Hexanes: *i*-PrOH eluent 1.00 mL/min flow rate and a lamp setting of 210 nm)  $t_r$  (major) = 8.659 and  $t_r$  (minor) = 10.907; <sup>1</sup>H NMR (500 MHz, CDCl<sub>3</sub>)  $\delta$  7.34-7.21 (m, 5H), 2.99-2.95 (m, 1H), 2.79 (dd,  $J = 3.0$  Hz, 2H), 2.74 (dt, 4.0,  $J = 1.0$  Hz, 1H), 2.46 (q,  $J = 2.7$  Hz, 1H), 1.90-1.82 (m, 2H); <sup>13</sup>C NMR (125 MHz, CDCl<sub>3</sub>)  $\delta$  141.5, 128.6, 128.5, 126.2, 52.0, 47.5, 34.5, 32.5; IR (thin film) 2860, 1496, 700 cm<sup>-1</sup>.



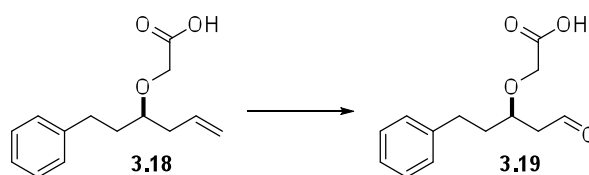
**1-Phenylhex-5-en-3-ol (3.17).** To a 250 mL flask containing CuI was added 60 mL of Et<sub>2</sub>O. The solution was put under N<sub>2</sub> and cooled to -78°C. Vinylmagnesium bromide was added dropwise, and the solution stirred for 30 min. while warming slightly. To the brown/green mixture was added a solution of epoxide **3.16a** (3.56 g, 24.02 mmol) in 40

mL Et<sub>2</sub>O. The syringe was washed with Et<sub>2</sub>O and the washings added to the flask. The reaction stirred for 4 h at -78 °C then was allowed to warm to 23 °C slowly overnight. The black mixture was then quenched with sat'd. NH<sub>4</sub>Cl (60 mL) and extracted with CH<sub>2</sub>Cl<sub>2</sub> (3 X 50 mL). The organic phases were combined and washed with aqueous sat'd NaCl, dried over Na<sub>2</sub>SO<sub>4</sub>, and concentrated *in vacuo*. The crude material was purified by flash column chromatography (2:3 EtOAc:Hexanes) to yield alcohol **3.17** (4.0 g, 95%) as a pale yellow oil.  $R_f = 0.33$  (EtOAc:Hexanes = 2:3); <sup>1</sup>H NMR (500 MHz, CDCl<sub>3</sub>) δ 7.31-7.18 (m, 5H), 5.85-5.77 (m, 1H), 5.05-4.97 (m, 2H), 3.49-3.45 (m, 1H), 3.41 (s, 1H) 2.75-2.65 (m, 2H), 2.16-2.12 (m, 2H), 1.90-1.63 (m, 2H); <sup>13</sup>C NMR (125 MHz, CDCl<sub>3</sub>) δ 142.2, 134.8, 128.6, 128.5, 126.0, 118.4, 70.1, 42.2, 38.5, 32.1; IR (thin film) 3450, 1739 cm<sup>-1</sup>.



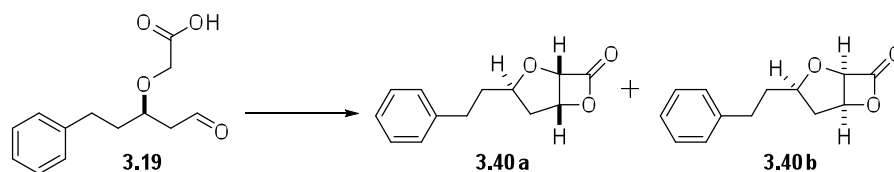
**2-(1-Phenylhex-5-en-3-yloxy)acetic Acid (3.18).** NaH, dissolved in mineral oil, (1.85 g, 55.17 mmol) was washed over a fritted glass funnel with hexanes (3 X 10 mL) then placed in a 100 mL flask and diluted with THF (10 mL). Iodoacetic acid (3.19 g, 17.15 mmol) was diluted with THF (10 mL) and added to the flask. The mixture bubbled and generated heat. The reaction stirred for 30 min., then alcohol **3.17** (1.59 g, 9.03 mmol) diluted in THF (6 mL) was added to the flask. The reaction mixture was put under N<sub>2</sub> and covered with aluminum foil and allowed to react for 72 h at 23 °C. The grey-green

mixture was diluted with  $\text{CH}_2\text{Cl}_2$  (200 mL) then sat'd.  $\text{NH}_4\text{Cl}$  (125 mL). The pale yellow solution was acidified with 10%  $\text{H}_2\text{SO}_4$  to pH 1. The mixture was extracted with  $\text{CH}_2\text{Cl}_2$  (3 X 30 mL), the organic layers combined, dried over  $\text{Na}_2\text{SO}_4$ , and concentrated *in vacuo*. The crude material was purified by gradient flash column chromatography (3:7→10:0 EtOAc:Hexanes) to yield alkene acid **3.18** (1.39 g, 66%) as a light brown oil.  $R_f = 0.61$  (EtOAc:Hexanes = 7:3);  $^1\text{H}$  NMR (500 MHz,  $\text{CDCl}_3$ )  $\delta$  7.53-7.08 (m, 5H), 5.81 (ddd,  $J = 10.6, 3.6, 3.0$  Hz, 1H), 5.17-4.79m (m, 2H), 4.13 (s, 2H), 3.63-3.35 (m, 1H), 2.91-2.51 (m, 2H), 2.25-2.04 (m, 2H), 1.97-1.55 (m, 2H);  $^{13}\text{C}$  NMR (125 MHz,  $\text{CDCl}_3$ )  $\delta$  174.5, 141.8, 134.0, 128.7, 128.65, 128.5, 128.5, 126.1, 118.3, 80.1, 66.3, 38.2, 35.5, 31.6; IR (thin film) 2937, 1641, 1127  $\text{cm}^{-1}$ ; m/z: calc. 235.1329 [M+H], found 235.1469.



**2-(1-oxo-5-Phenylpentan-3-yloxy)acetic Acid (3.19).** To a 50 mL flask was added alkene acid **3.18** (1.00 g, 4.27 mmol) in  $\text{CH}_2\text{Cl}_2$  (15 mL). This was cooled to  $-78^\circ\text{C}$  under  $\text{N}_2$  for 30 min.  $\text{O}_3$  was bubbled through the solution until blue color appeared, ~1 min then  $\text{O}_2$  was bubbled through for 2 min. Crushed  $\text{PPh}_3$  was added to the solution (1.11 g, 4.27 mmol). The solution was allowed to warm slowly to  $23^\circ\text{C}$  overnight under  $\text{N}_2$ . The reaction mixture was concentrated and re-suspended in  $\text{CH}_2\text{Cl}_2$  (25 mL). The aldehyde acid was purified *via* acid-base extraction as described below.  $\text{NaHCO}_3$  was

added (50 mL) and the organic layer removed. The aqueous phase was washed with hexanes (1 X 50 mL) and the layers separated. The aqueous layer was acidified with 10% H<sub>2</sub>SO<sub>4</sub> to pH 2 then extracted with Et<sub>2</sub>O (4 X 40 mL) and CH<sub>2</sub>Cl<sub>2</sub> (2 X 50 mL). The organic extracts obtained after acidification were combined, dried over Na<sub>2</sub>SO<sub>4</sub>, and concentrated *in vacuo* to yield aldehyde acid **3.19** (0.49 g, 49%) as a viscous, colorless oil. *R<sub>f</sub>* = 0.55 (EtOAc:Hexanes = 8:2); <sup>1</sup>H NMR (500 MHz, CDCl<sub>3</sub>) δ 9.80 (s, 1H), 7.41-7.21 (m, 5H), 4.28 – 4.16 (m, 2H), 4.26-3.99 (m, 1H), 2.73 (dq, *J* = 7.6, 4.2 Hz, 2H), 2.70 (dt, *J* = 3.2 Hz, 2H), 2.01-1.88 (m, 2H); <sup>13</sup>C NMR (125 MHz, CDCl<sub>3</sub>) δ 201.7, 174.9, 158.3, 141.1, 128.7, 128.5, 128.4, 126.3, 75.1, 66.4, 48.2, 35.5, 34.4, 34.1, 32.2; IR (thin film) 2929, 1723, 1127 cm<sup>-1</sup>; *m/z*: calc. 237.1121 [M+H], found 237.1234.



**Racemic 3-Phenethyl-2,6-Dioxabicyclo[3.2.0]heptan-7-one (3.40a/3.40b).** To a 25 mL flask containing Mukaiyama's reagent (59.3 mg, 0.169 mmol) was added CH<sub>2</sub>Cl<sub>2</sub> (8 mL) under N<sub>2</sub> followed by Et<sub>3</sub>N (34.3 mg, 0.46 mL, 0.339 mmol). The clear liquid turned pale yellow then yellow/brown. Aldehyde acid **3.19** (227 mg, 0.0847 mmol), azeotroped in xylenes prior to reaction, was added as a solution in 1 mL CH<sub>2</sub>Cl<sub>2</sub> over 1 h *via* syringe pump and the reaction stirred for 2 h at 23 °C. The dark red solution was concentrated *in vacuo* and the crude mixture purified by flash column chromatography (2:8 EtOAc:Hexanes) to yield of β-lactones **3.40a/3.40b** (0.044 g, 21%) as a colorless

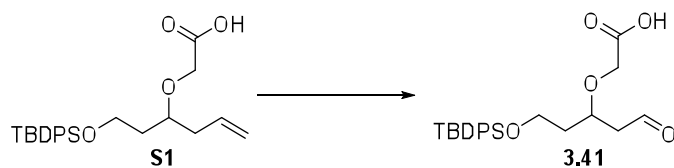
oil. **3.40a**:  $R_f = 0.30$  (EtOAc:Hexanes = 1:4);  $^1\text{H NMR}$  (500 MHz,  $\text{CDCl}_3$ )  $\delta$  7.24-7.12 (m 5H), 5.44 (d,  $J = 3.5$  Hz, 1H), 5.11 (t,  $J = 3.9$  Hz, 1H), 4.11 (tt,  $J = 5.0, 2.5$  Hz, 1H), 2.76-2.62 (m, 2H), 1.98-1.90 (m, 2H), 1.49-1.42 (m, 2H);  $^{13}\text{C NMR}$  (125 MHz,  $\text{CDCl}_3$ )  $\delta$  128.6, 128.4, 126.2, 88.0, 78.7, 78.4, 36.5, 35.5, 32.3, 29.7; IR (thin film) 1831, 1600  $\text{cm}^{-1}$ . **3.40b**:  $R_f = 0.18$  (EtOAc:Hexanes = 1:4);  $^1\text{H NMR}$  (500 MHz,  $\text{CDCl}_3$ )  $\delta$  7.23-7.12 (m, 5H), 5.40 (d,  $J = 3.9$  Hz, 1H), 5.20 (dt,  $J = 4.6, 1.0$  Hz, 1H), 4.54 (tt,  $J = 5.3, 2.5$  Hz, 1H), 2.74-2.60 (m, 2H), 2.14-2.09 (m, 2H), 1.82-1.71 (m, 2H);  $^{13}\text{C NMR}$  (125 MHz,  $\text{CDCl}_3$ )  $\delta$  128.6, 128.5, 126.0, 88.1, 83.0, 79.6, 37.9, 34.8, 32.6, 29.7; IR (thin film) 1831, 1600  $\text{cm}^{-1}$ ; m/z: calc. 241.0835 [M+Na], found 241.1585.

**Optically Pure 3-Phenethyl-2,6-Dioxabicyclo[3.2.0]heptan-7-one (3.40a/3.40b).** To a 10 mL flask containing OTMS-QD (9.9 mg, 0.025 mmol) and Mukaiyama's reagent (267 mg, 0.762 mmol) was added 0.2 mL  $\text{CH}_2\text{Cl}_2$  and Hünig's base (0.13 mL, 0.100 mmol). Aldehyde acid **3.19** was azeotroped in xylenes prior to reaction then dissolved in 0.5 mL  $\text{CH}_2\text{Cl}_2$  and added to the flask *via* syringe pump over 1 h. The solution turned from yellow to dark red-brown as the reaction progressed. The syringe was washed (2 X 0.25 mL) with  $\text{CH}_2\text{Cl}_2$  and the washings added to the reaction vessel. The reaction stirred for 24 h at 23 °C then was concentrated *in vacuo*. The crude material was purified by flash column chromatography (2:8 EtOAc:Hexanes) to yield  $\beta$ -lactones **3.40a/3.40b** (6.9 mg, 12.5%) as colorless oils with a 5:1 dr. **3.40a**:  $R_f = 0.30$  (EtOAc:Hexanes = 1:4);  $^1\text{H NMR}$  (500 MHz,  $\text{CDCl}_3$ )  $\delta$  7.24-7.12 (m 5H), 5.44 (d,  $J = 3.5$  Hz, 1H), 5.11 (t,  $J = 3.9$  Hz, 1H), 4.11 (tt,  $J = 5.0, 2.5$  Hz, 1H), 2.76-2.62 (m, 2H),

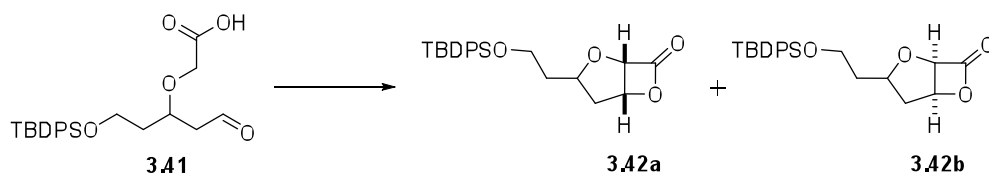
1.98-1.90 (m, 2H), 1.49-1.42 (m, 2H);  $^{13}\text{C}$  NMR (125 MHz,  $\text{CDCl}_3$ )  $\delta$  128.6, 128.4, 126.2, 88.0, 78.7, 78.4, 36.5, 35.5, 32.3, 29.7; IR (thin film) 1831, 1600  $\text{cm}^{-1}$ . **3.40b**:  $R_f$  = 0.18 (EtOAc:Hexanes = 1:4);  $^1\text{H}$  NMR (500 MHz,  $\text{CDCl}_3$ )  $\delta$  7.23-7.12 (m, 5H), 5.40 (d,  $J$  = 3.9 Hz, 1H), 5.20 (dt,  $J$  = 4.6, 1.0 Hz, 1H), 4.54 (tt,  $J$  = 5.3, 2.5 Hz, 1H), 2.74-2.60 (m, 2H), 2.14-2.09 (m, 2H), 1.82-1.71 (m, 2H);  $^{13}\text{C}$  NMR (125 MHz,  $\text{CDCl}_3$ )  $\delta$  128.6, 128.5, 126.0, 88.1, 83.0, 79.6, 37.9, 34.8, 32.6, 29.7; IR (thin film) 1831, 1600  $\text{cm}^{-1}$ ; m/z: calc. 241.0835 [M+Na], found 241.1585.

**Optically Pure 3-Phenethyl-2,6-Dioxabicyclo[3.2.0]heptan-7-one (3.40a/3.40b).** To a 10 mL flask containing OTMS-QN (9.9 mg, 0.025 mmol) and Mukaiyama's reagent (270 mg, 0.76 mmol) was added 0.2 mL  $\text{CH}_2\text{Cl}_2$  and Hünig's base (0.13 mL, 0.100 mmol) Aldehyde acid **3.19** was azeotroped in xylenes prior to reaction then dissolved in 0.5 mL  $\text{CH}_2\text{Cl}_2$  and added to the flask *via* syringe pump over 1 h. The solution turned from yellow to dark red-brown as the reaction progressed. The syringe was washed (2 X 0.25 mL) with  $\text{CH}_2\text{Cl}_2$  and the washings added to the flask. The reaction stirred for 24 h at 23 °C then was concentrated *in vacuo*. The crude material was directly purified by flash column chromatography (2:8 EtOAc:Hexanes) to yield  $\beta$ -lactones **3.40a/3.40b** (8.6 mg, 16%) as colorless oils (dr = 1:1); m/z: calc. 241.0835 [M+Na], found 241.1585.



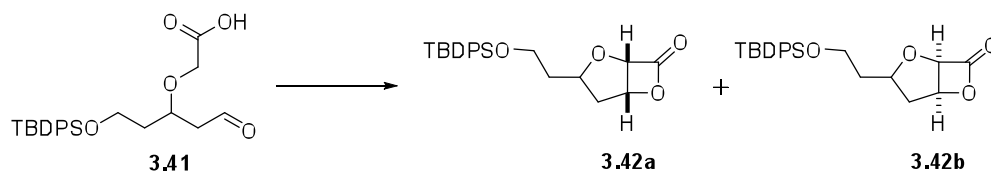


**2-(1-(tert-butyldimethylsilyloxy)-5-oxopentan-3-yloxy)acetic acid (3.41).** To a 25 mL flask was added alkene acid **S1** (250 mg, 0.606 mmol) in CH<sub>2</sub>Cl<sub>2</sub> (10 mL). This was cooled to -78°C under N<sub>2</sub> for 30 min. O<sub>3</sub> was bubbled through the solution until blue color appeared, ~30 seconds, then O<sub>2</sub> was bubbled through for 1 min. To the solution was added dimethylsulfide (380 mg, 0.47 mL, 6.0 mmol). The solution was allowed to slowly warm to 23 °C overnight under N<sub>2</sub>. The reaction was quenched with sat'd NaCl (20 mL) and the organic layer extracted. The aqueous phase was washed with dichloromethane (2 X 20 mL) and the layers separated. The organic layers were combined, dried over Na<sub>2</sub>SO<sub>4</sub>, and concentrated *in vacuo*. The crude material was purified *via* flash column chromatography on silica gel (5:2:88 acetone:AcOH:CH<sub>2</sub>Cl<sub>2</sub>) to yield racemic aldehyde acid **3.41** (180 mg, 72%) as a colorless oil. **3.41**: R<sub>f</sub> = 0.44 (EtOAc:Hexanes = 1:4); <sup>1</sup>H NMR (500 MHz, CDCl<sub>3</sub>) δ 9.80 (s, 1H), 7.78 – 7.64 (m, 4H), 7.54 – 7.35 (m, 6H), 4.19 (s, 2H), 4.02 – 3.70 (m, 2H), 2.75 (dd, *J* = 7.8, 1.4 Hz, 2H), 2.68 (d, *J* = 3.6 Hz, 1H), 2.04 – 1.70 (m, 2H), 1.10 (s, 9H); <sup>13</sup>C NMR (125 MHz, CDCl<sub>3</sub>) δ 201.9, 175.1, 135.8, 133.6, 130.2, 128.1, 73.5, 66.8, 60.1, 48.7, 36.7, 27.2, 19.4; IR (thin film): 3072, 2859, 1728, 1112 cm<sup>-1</sup>.



### 3-(2-(tert-butyldimethylsilyloxy)ethyl)-2,6-dioxabicyclo[3.2.0]heptan-7-one

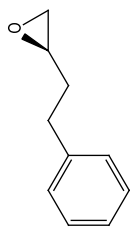
**(3.42a/3.42b).** To a 10 mL flask containing tetramisole (34.5 mg, 0.169 mmol) and Mukaiyama's reagent (118 mg, 0.338 mmol) was added 1.5 mL CH<sub>2</sub>Cl<sub>2</sub> and Hünig's base (0.065 mL, 0.371 mmol, 2 equiv). Racemic aldehyde acid **3.41** (70.0 mg, 0.169 mmol) was azeotroped in xylenes prior to reaction then dissolved in 1.0 mL CH<sub>2</sub>Cl<sub>2</sub> and added to the flask *via* syringe pump over 1 h. The solution turned from a yellow to a dark red-brown as the reaction progressed. The syringe was washed (2 X 0.44 mL) with CH<sub>2</sub>Cl<sub>2</sub> and the washings added to the flask. The reaction stirred for 18 h at 23 °C then was concentrated *in vacuo*. The crude material was taken directly onto purification by gradient flash column chromatography (2:8→10:0 EtOAc:Hexanes) to yield β-lactones **3.42a/3.42b** (4.0 mg, 9%) as colorless oils. **3.40a/3.40b**: *R<sub>f</sub>* = 0.44 (EtOAc/Hexanes = 1:4); <sup>1</sup>H NMR (300 MHz, CDCl<sub>3</sub>) δ 7.71-7.65 (m, 5H), 7.45-7.29 (m, 5H), 5.44 (d, *J* = 3.8 Hz, 1H), 5.40 (d, *J* = 4.0 Hz, 1H), 5.24 (t, *J* = 4.0 Hz, 1H), 5.15 (t, *J* = 3.82 Hz, 1H), 4.98-4.93 (m, 1H), 4.39-4.32 (m, 1H), 3.84-3.73 (m, 2H) 3.83-3.79 (m, 2H), 2.38 (d, *J* = 1.9 Hz, 2H), 2.33 (d, *J* = 1.7 Hz, 2H), 2.29-2.24 (m, 2H), 2.24-2.19 (m, 2H), 2.07-1.94 (m 2H), 1.91-1.81 (m, 2H), 1.63-1.58 (m, 2H), 1.57-1.53 (m, 2H), 1.09(s, 9H), 1.08(s, 9H); <sup>13</sup>C NMR (125 MHz, CDCl<sub>3</sub>) δ 170.3, 168.8, 135.7, 133.7, 129.9, 127.9, 105.2, 88.2, 88.0, 81.3, 80.0, 78.7, 60.8, 38.7, 37.0, 34.8, 27.0, 19.4; IR (thin film): 2929, 1836, 1105 cm<sup>-1</sup>; *m/z*: calc. 419.1649 [M+Na], found 419.1892.



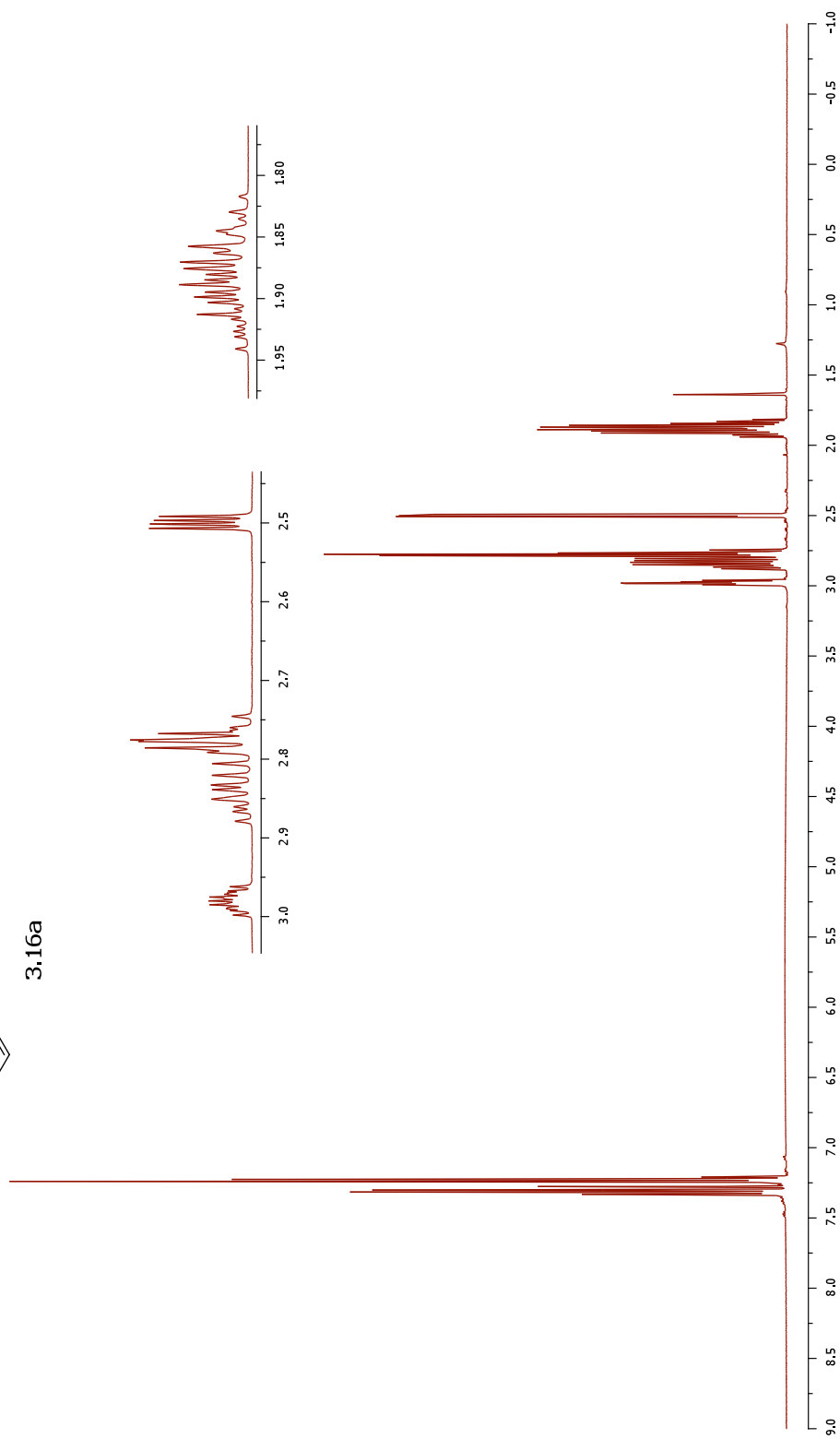
### 3-(2-(tert-butyldimethylsilyloxy)ethyl)-2,6-dioxabicyclo[3.2.0]heptan-7-one

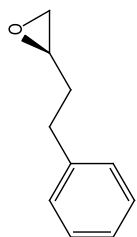
**(3.42a/3.42b).** To a 10 mL flask containing tetramisole (34.5 mg, 0.169 mmol) and Mukaiyama's reagent (118.4 mg, 0.338 mmol) was added 1.5 mL CH<sub>2</sub>Cl<sub>2</sub> and Hünig's base (0.118 mL, 0.676 mmol, 4 equiv). Racemic aldehyde acid **3.19** (70.0 mg, 0.169 mmol) was azeotroped in xylenes prior to reaction then dissolved in 1.0 mL CH<sub>2</sub>Cl<sub>2</sub> and added to the flask *via* syringe pump over 1 h. The solution turned from a yellow to a dark red-brown as the reaction progressed. The syringe was washed (2 X 0.44 mL) with CH<sub>2</sub>Cl<sub>2</sub> and the washings added to the flask. The reaction stirred for 18 h at 23 °C then was concentrated *in vacuo*. The crude material was taken directly onto purification by flash column chromatography (1:4 EtOAc:Hexanes). No desired product was formed. Instead, the major products of the reaction were  $\alpha$ ,  $\beta$ -unsaturated aldehyde **4.1** and  $\alpha$ ,  $\beta$ -unsaturated acid **4.2**.

**APPENDIX II**  
**SELECTED SPECTRAL DATA**

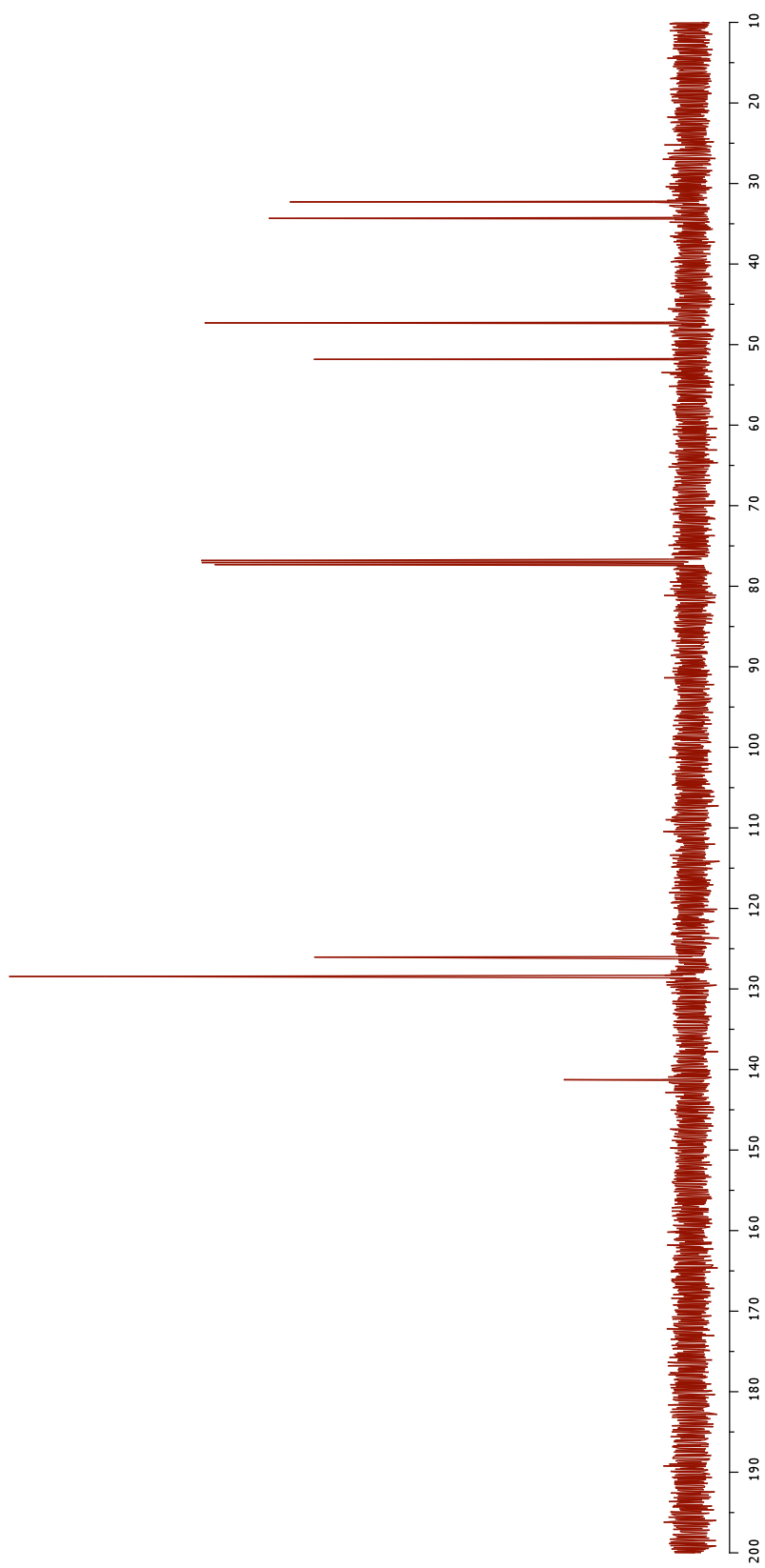


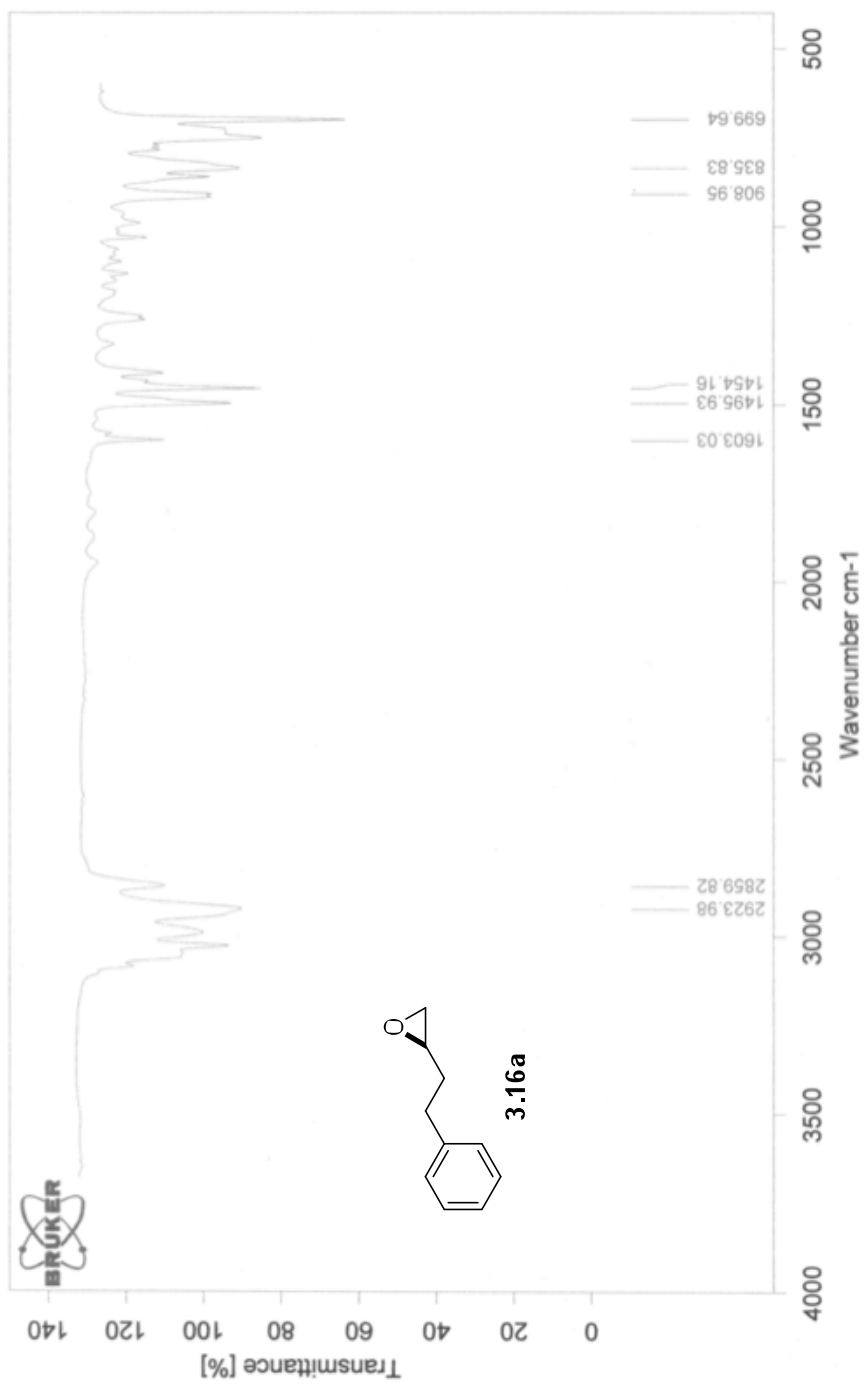
3.16a

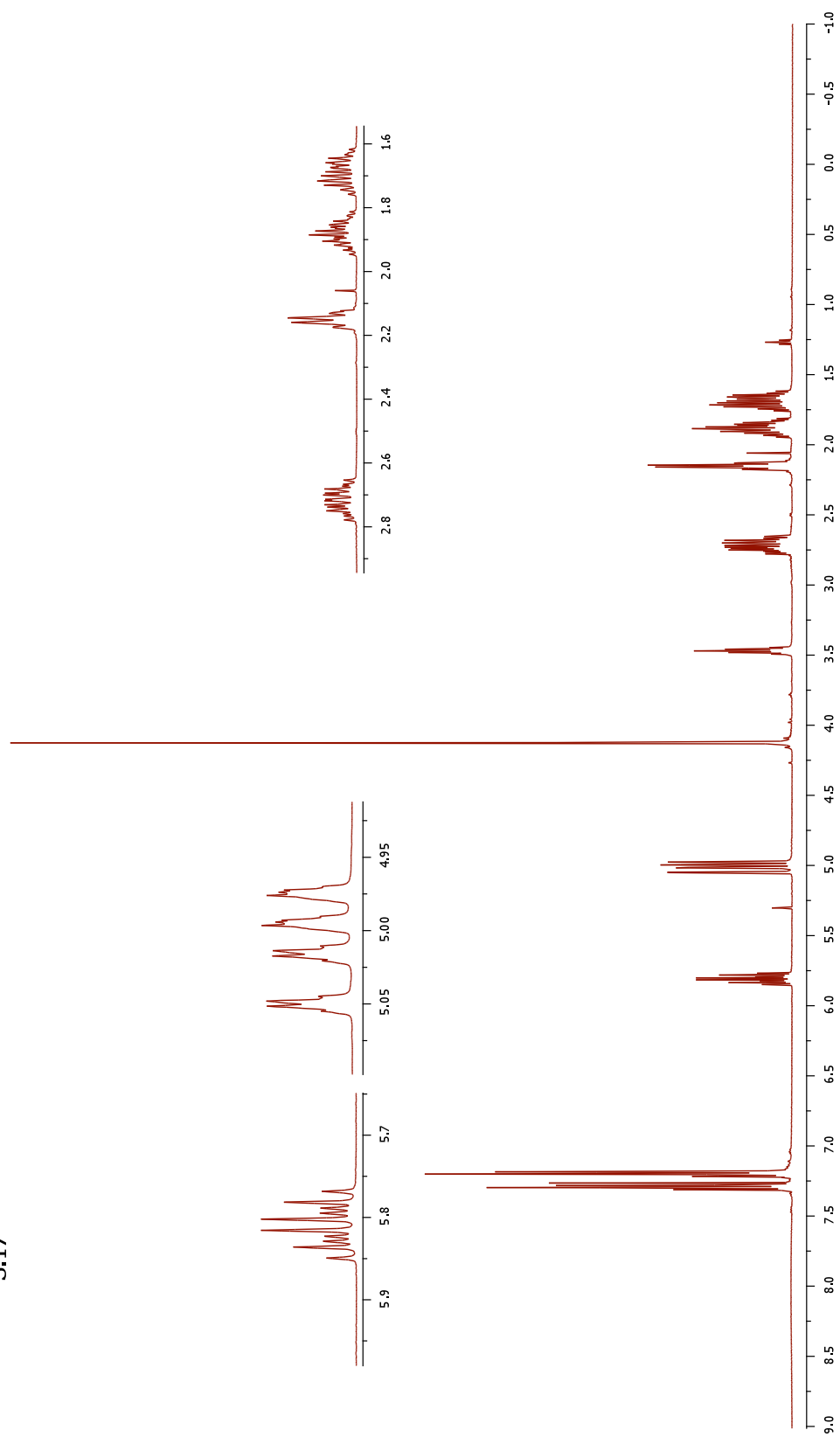
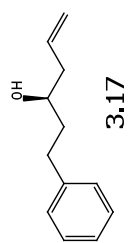




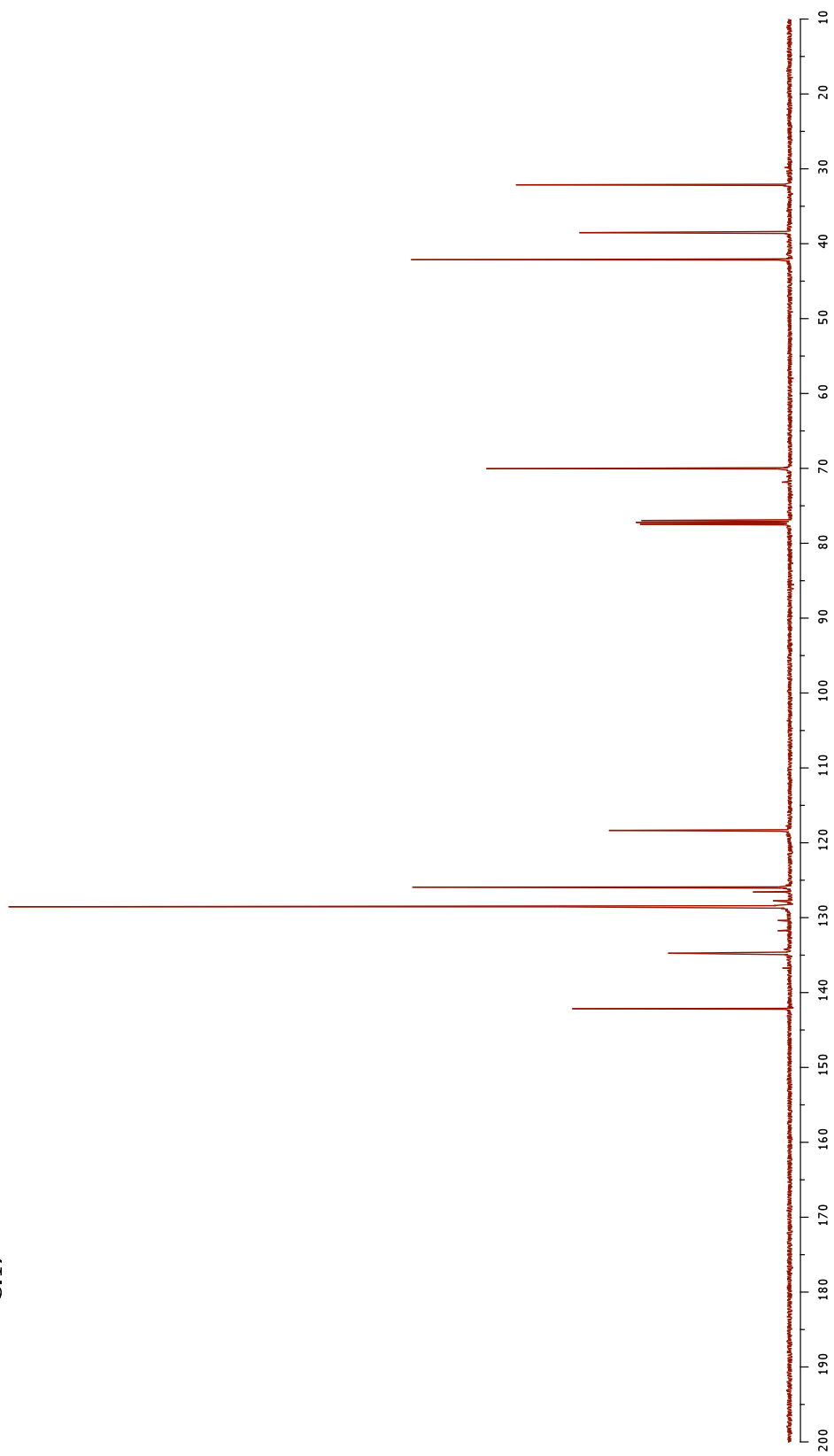
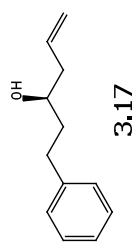
3.16a

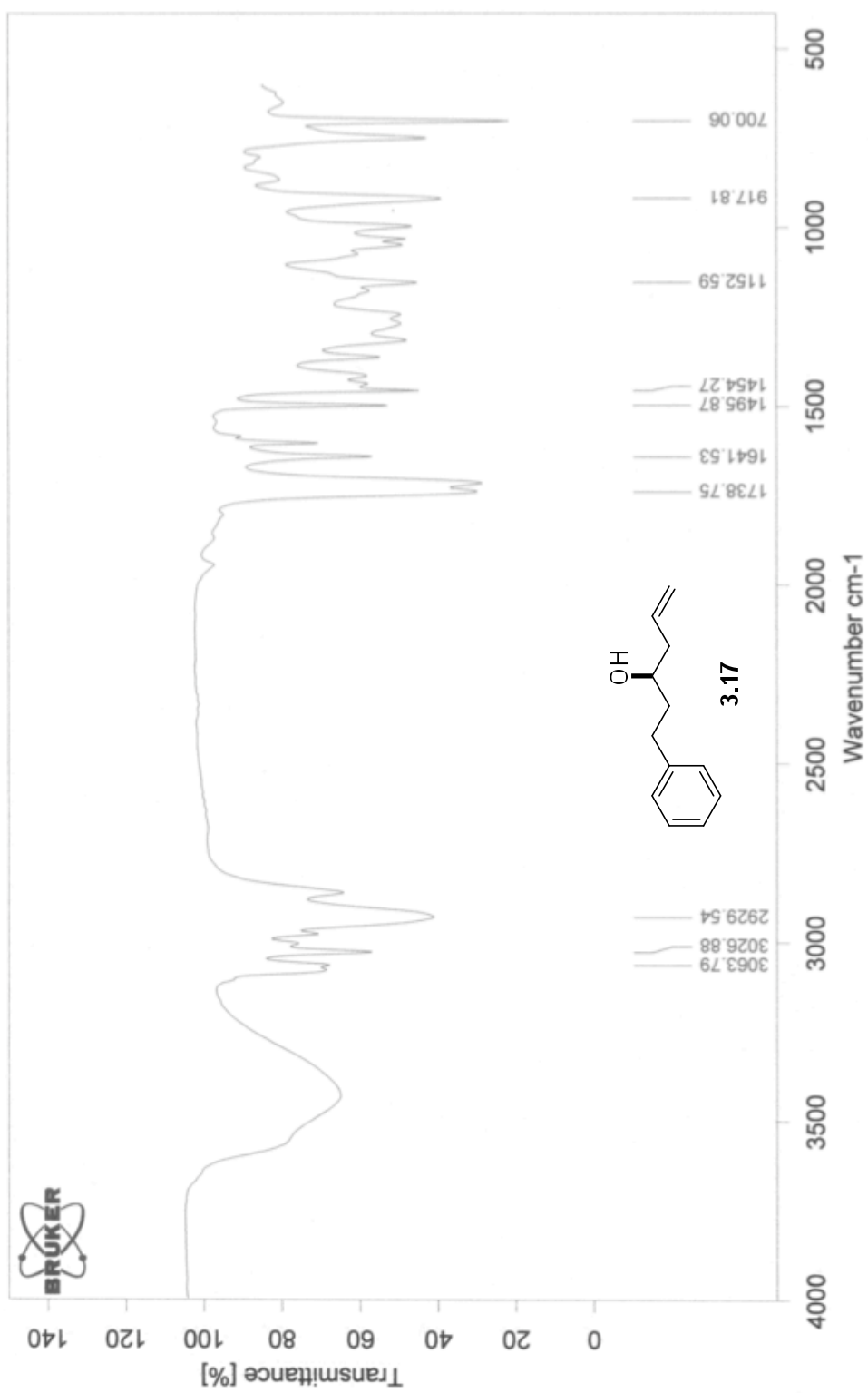


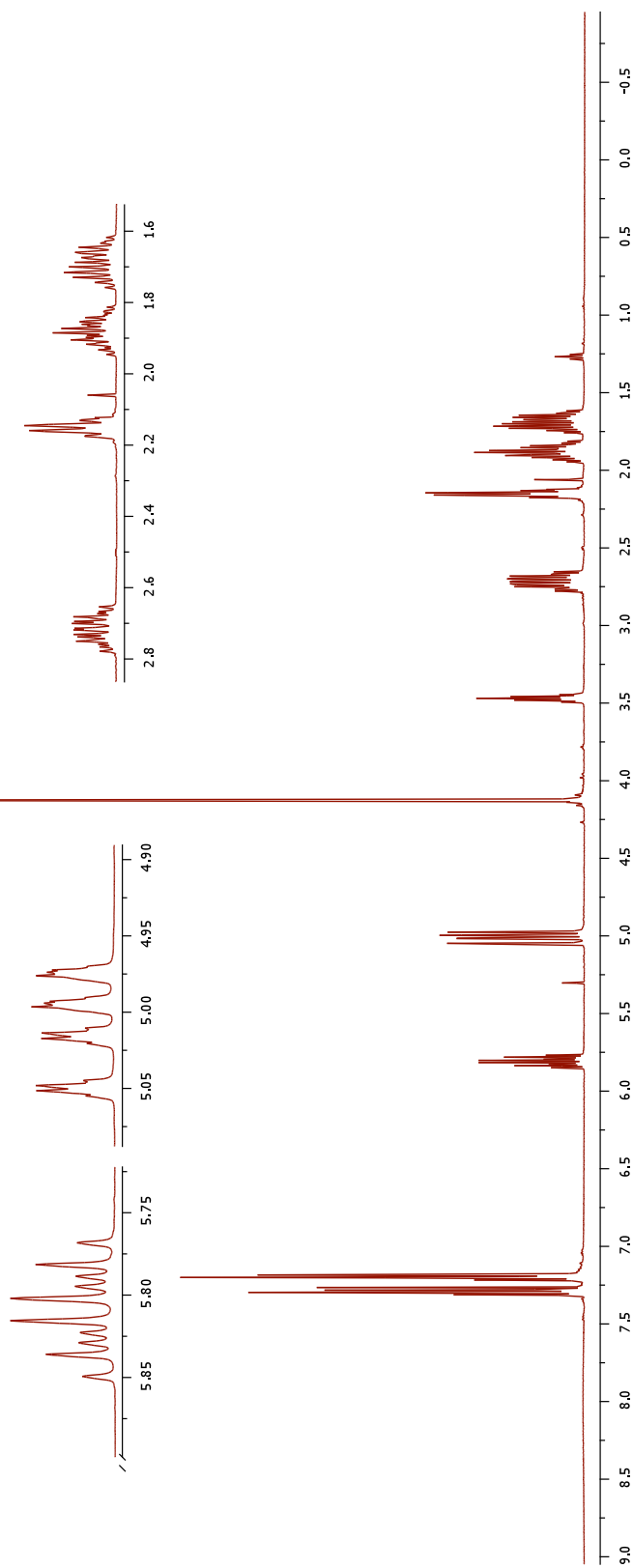
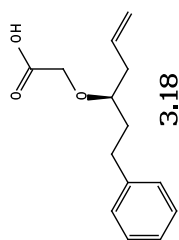


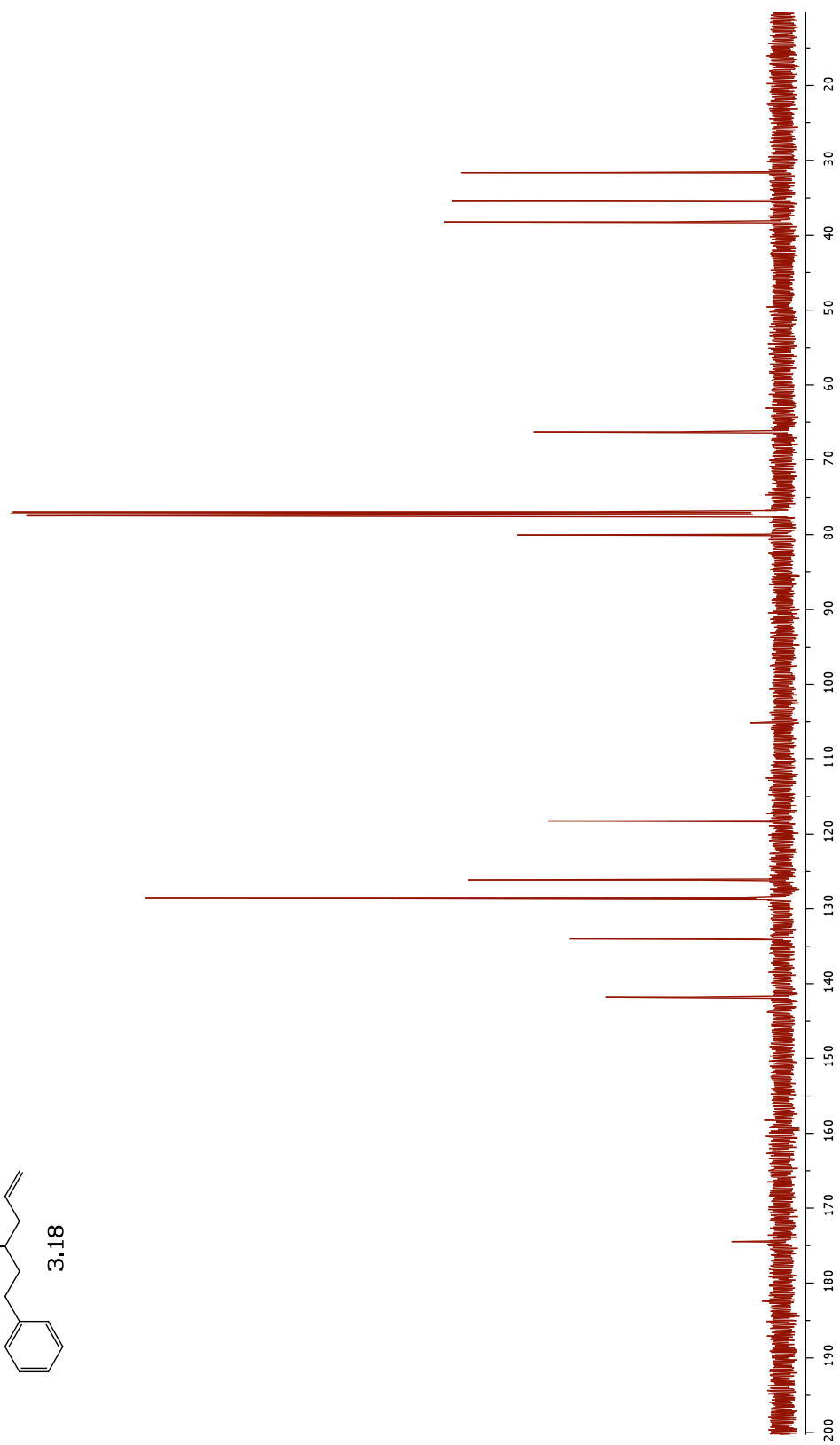
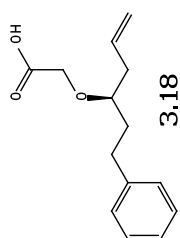


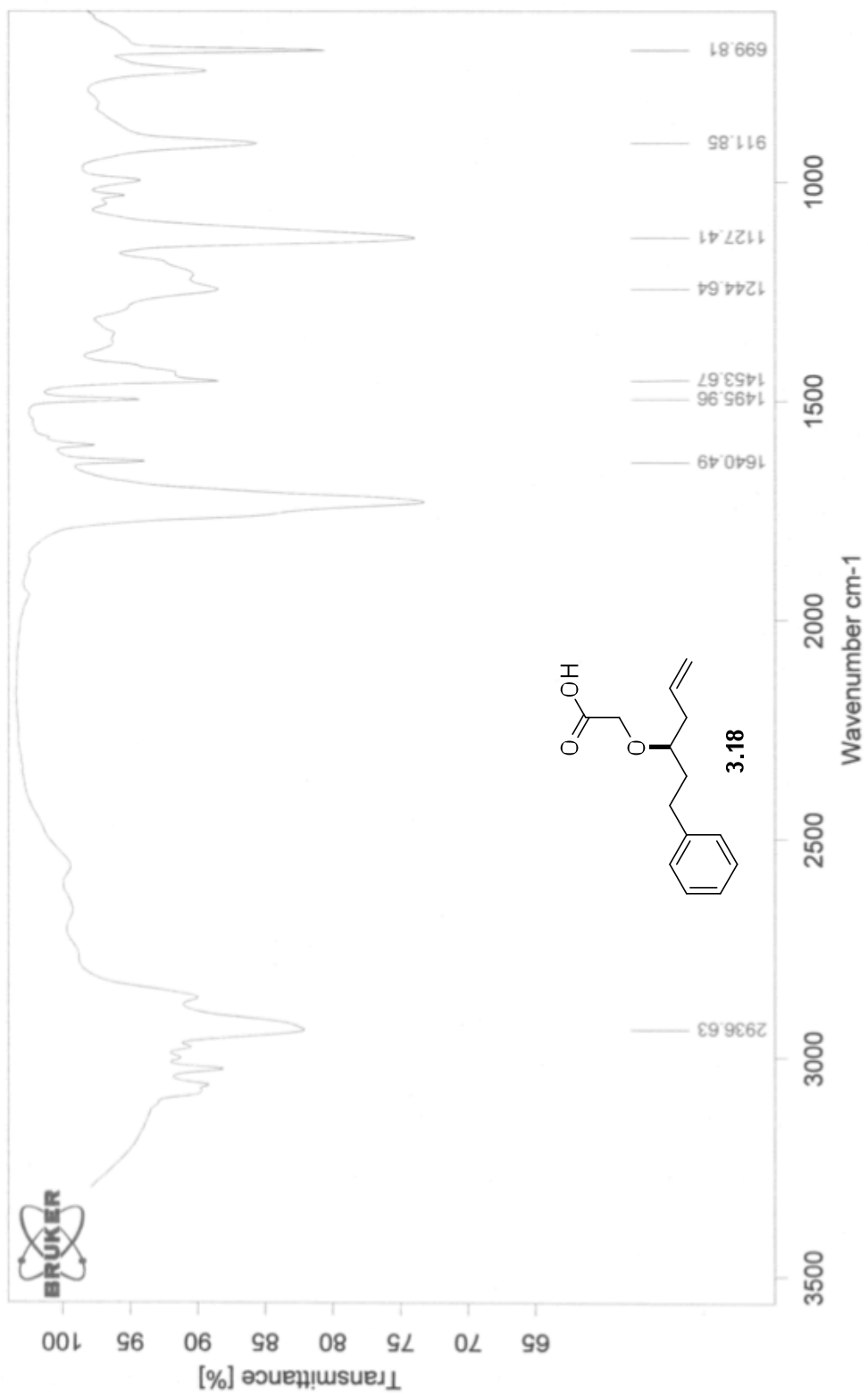


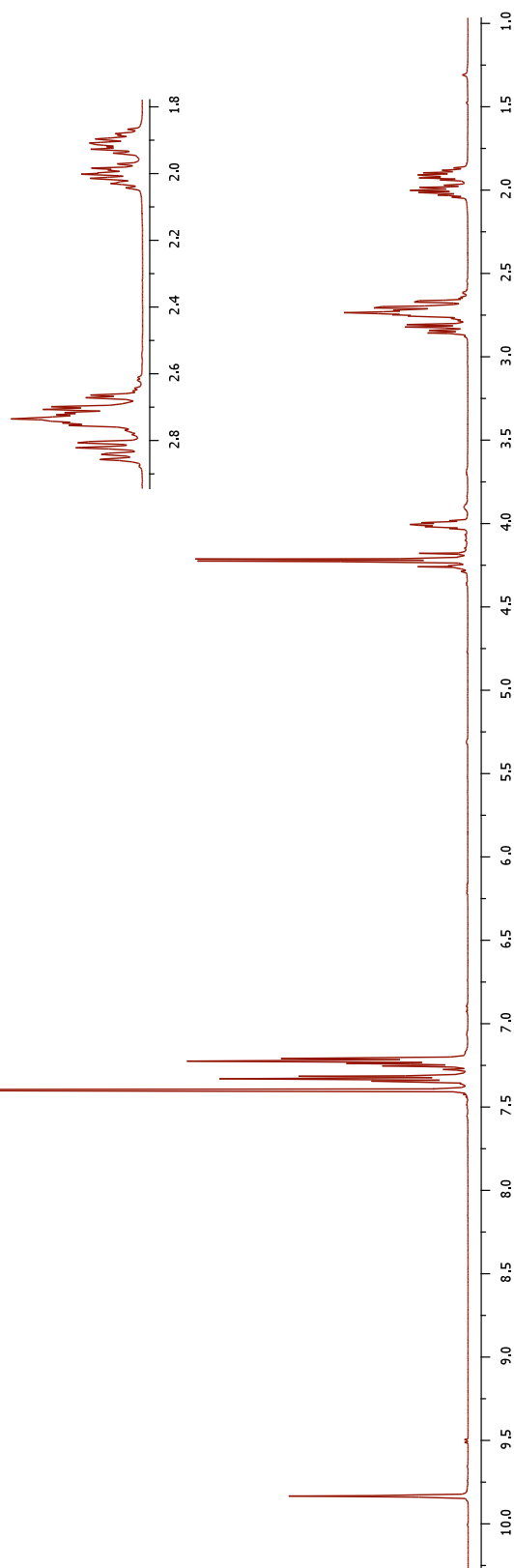
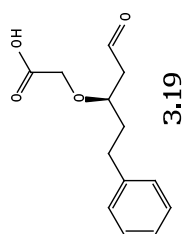


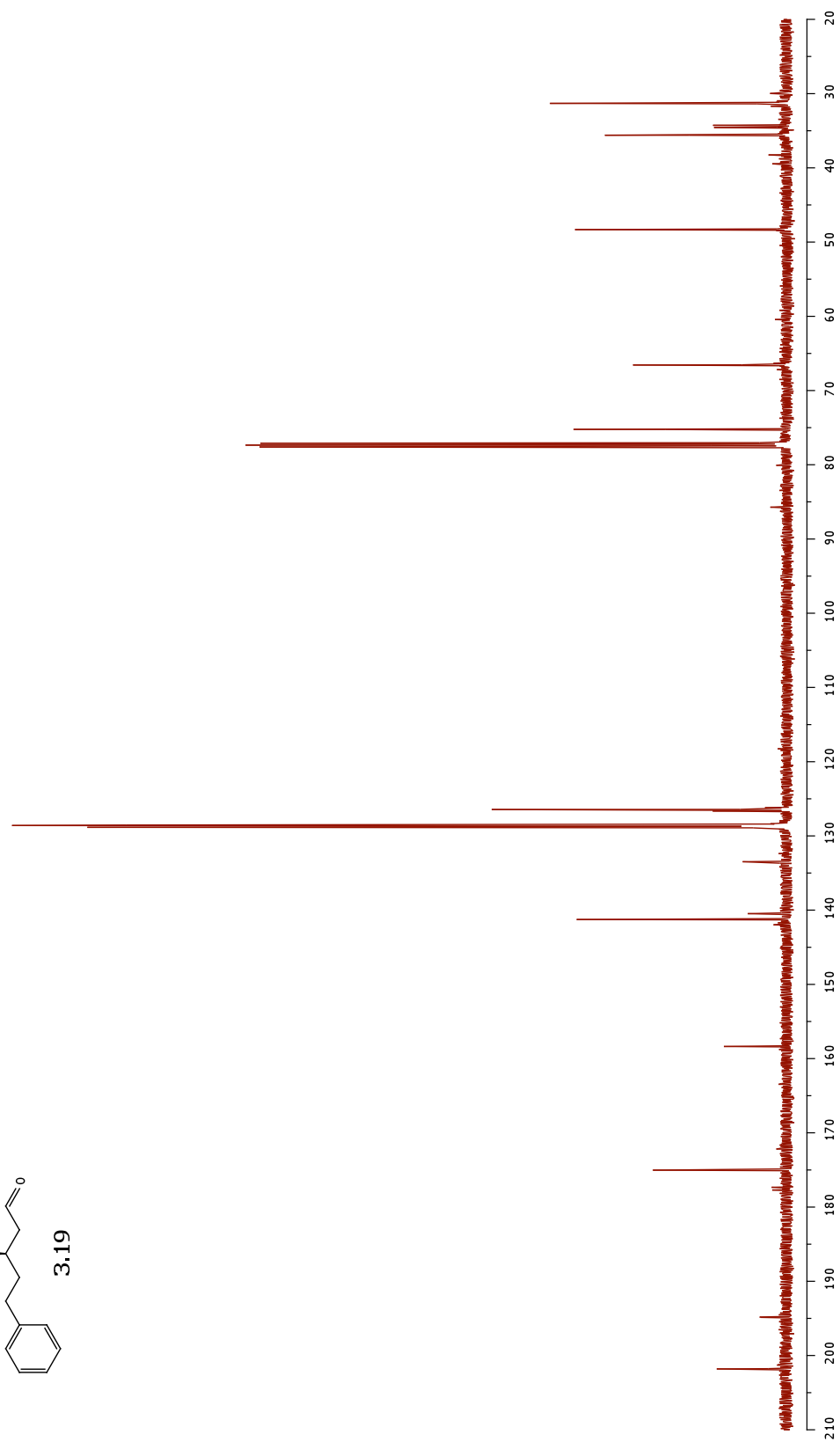
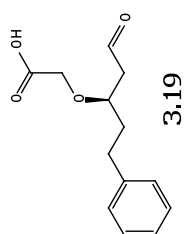


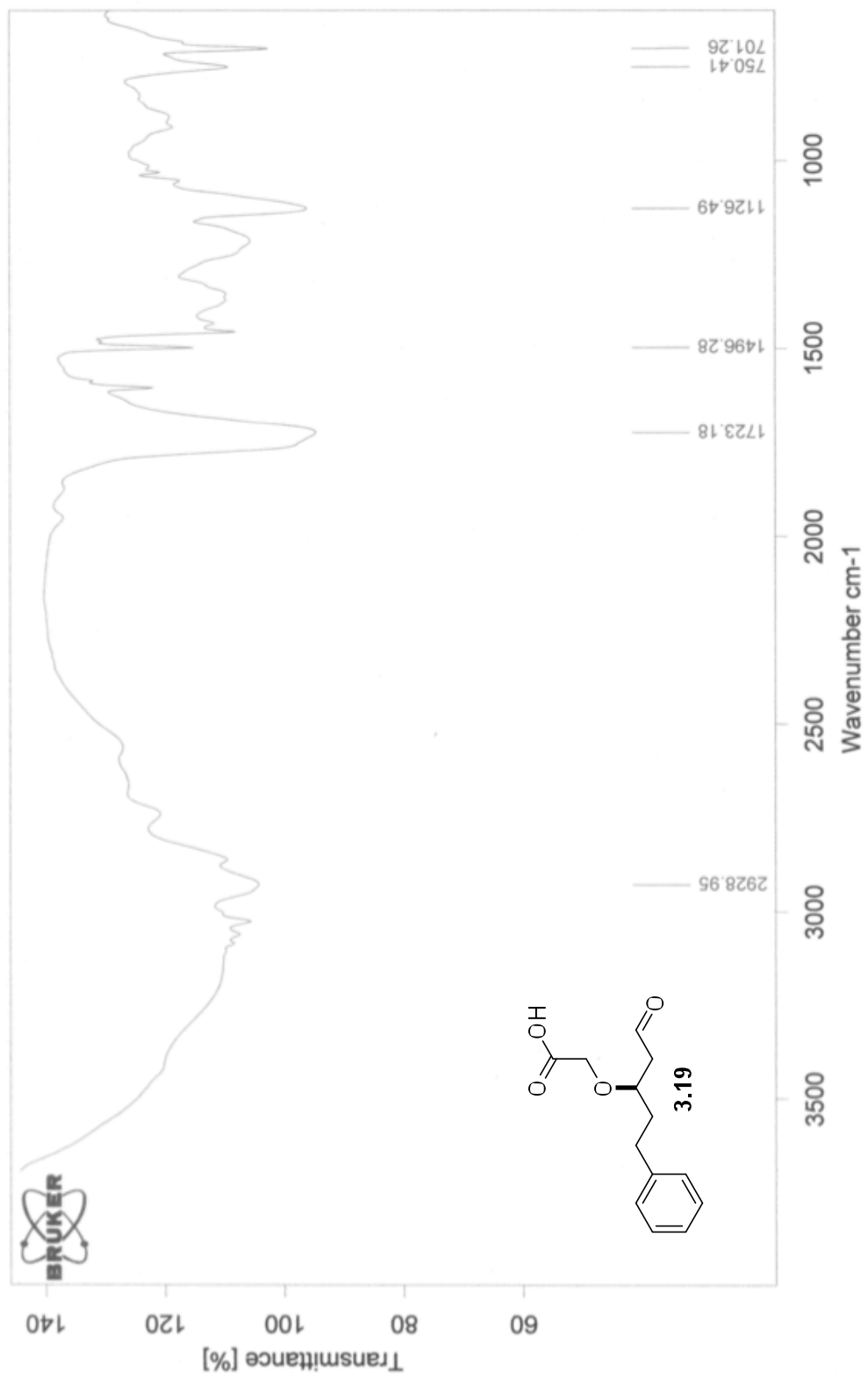




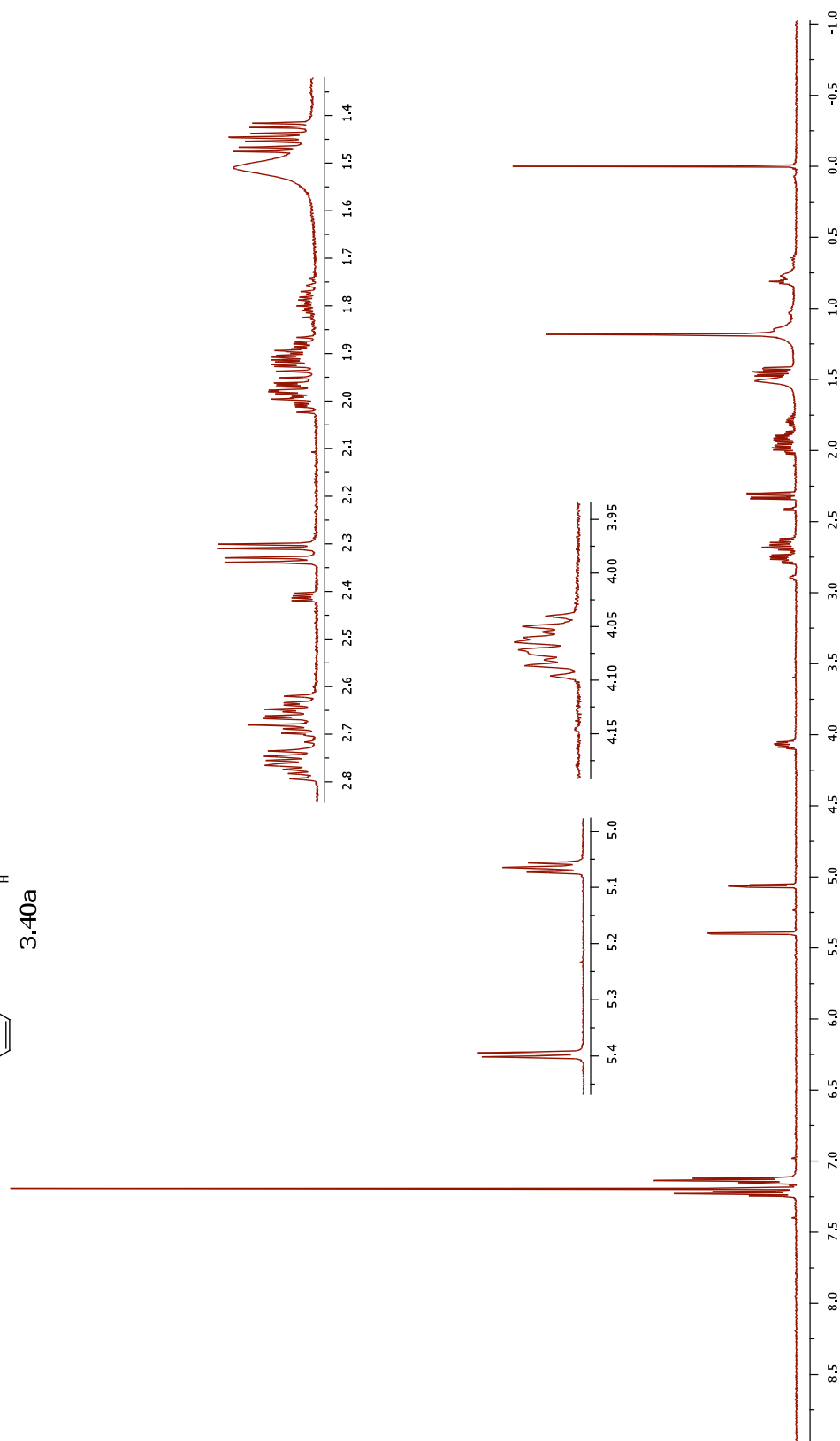
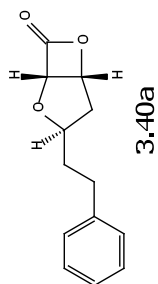


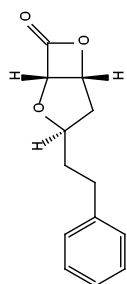




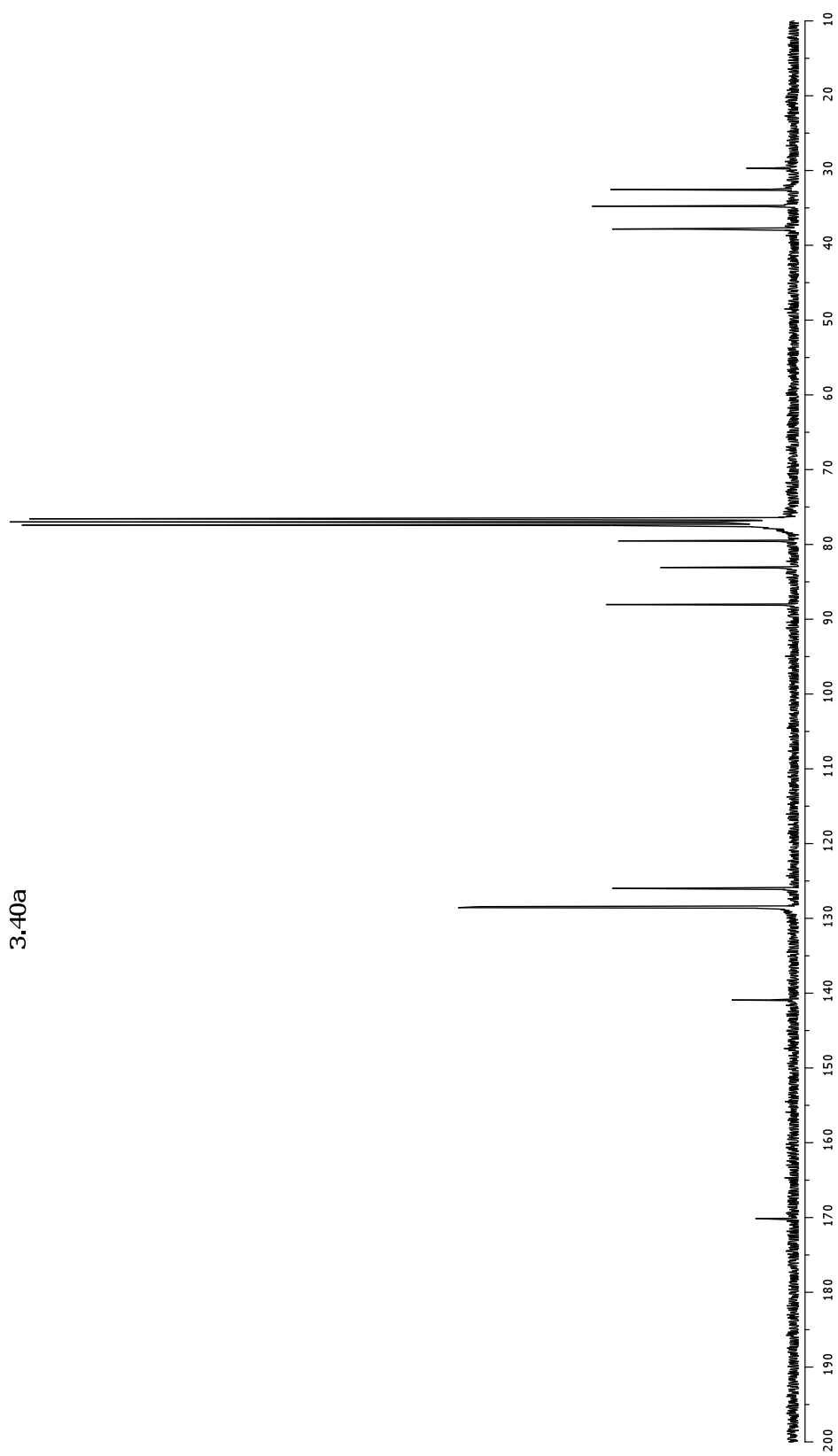


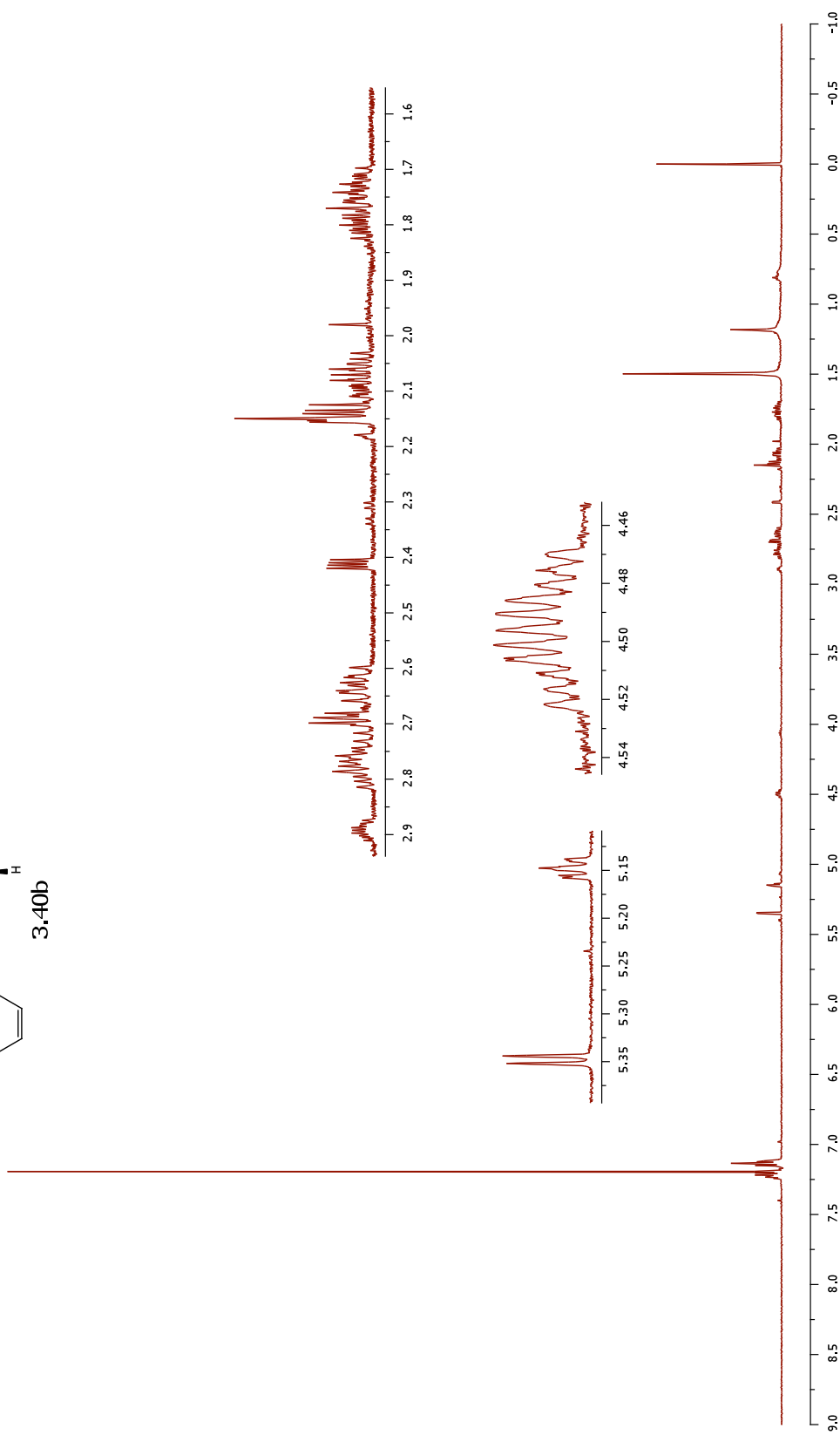
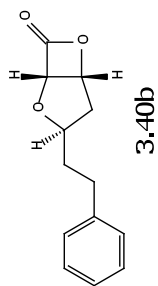


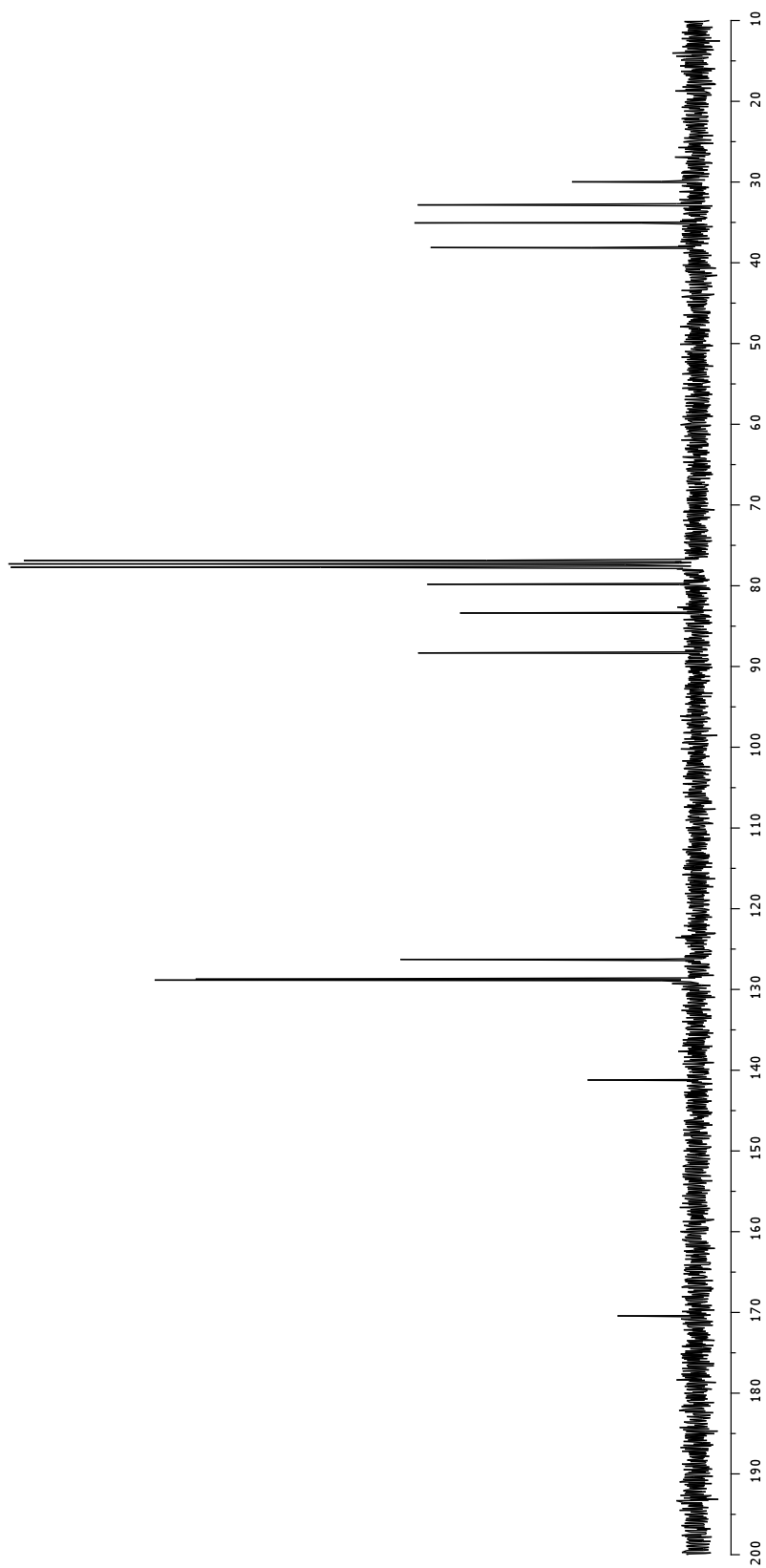
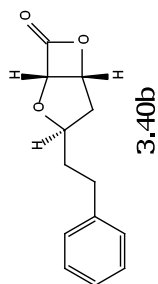


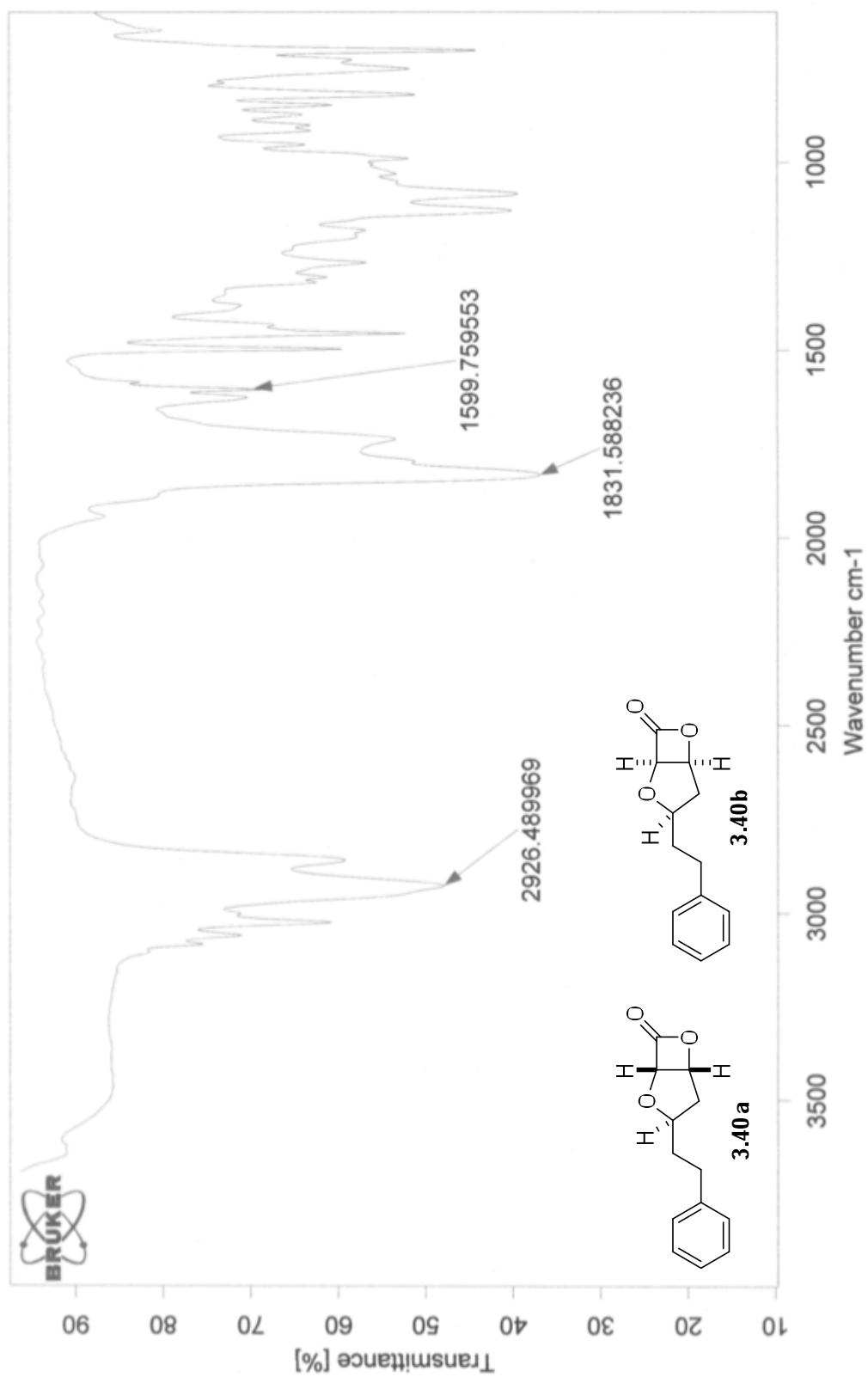


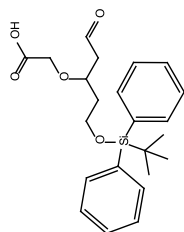
3.40a



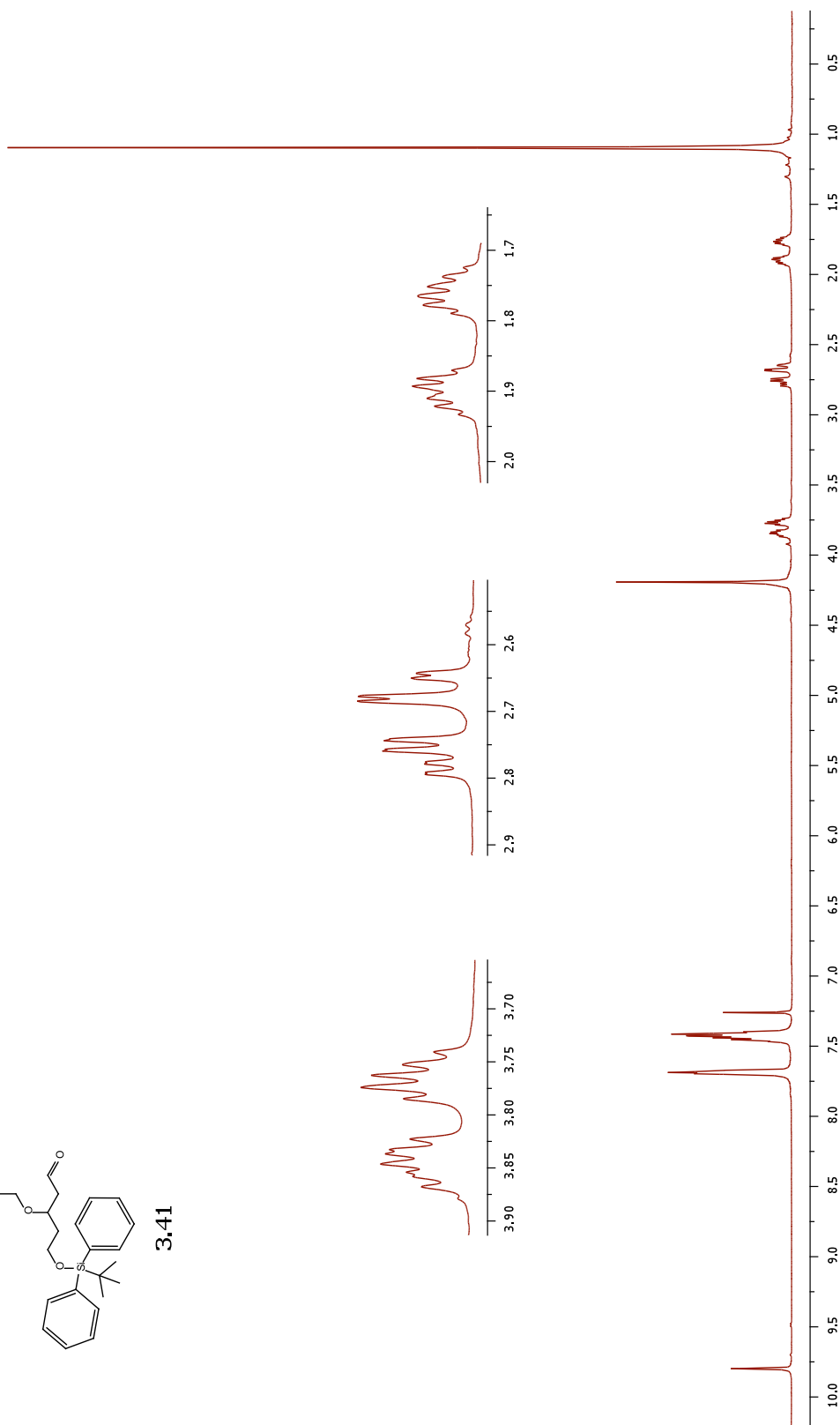


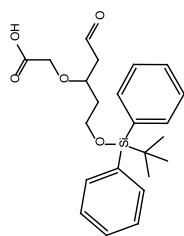




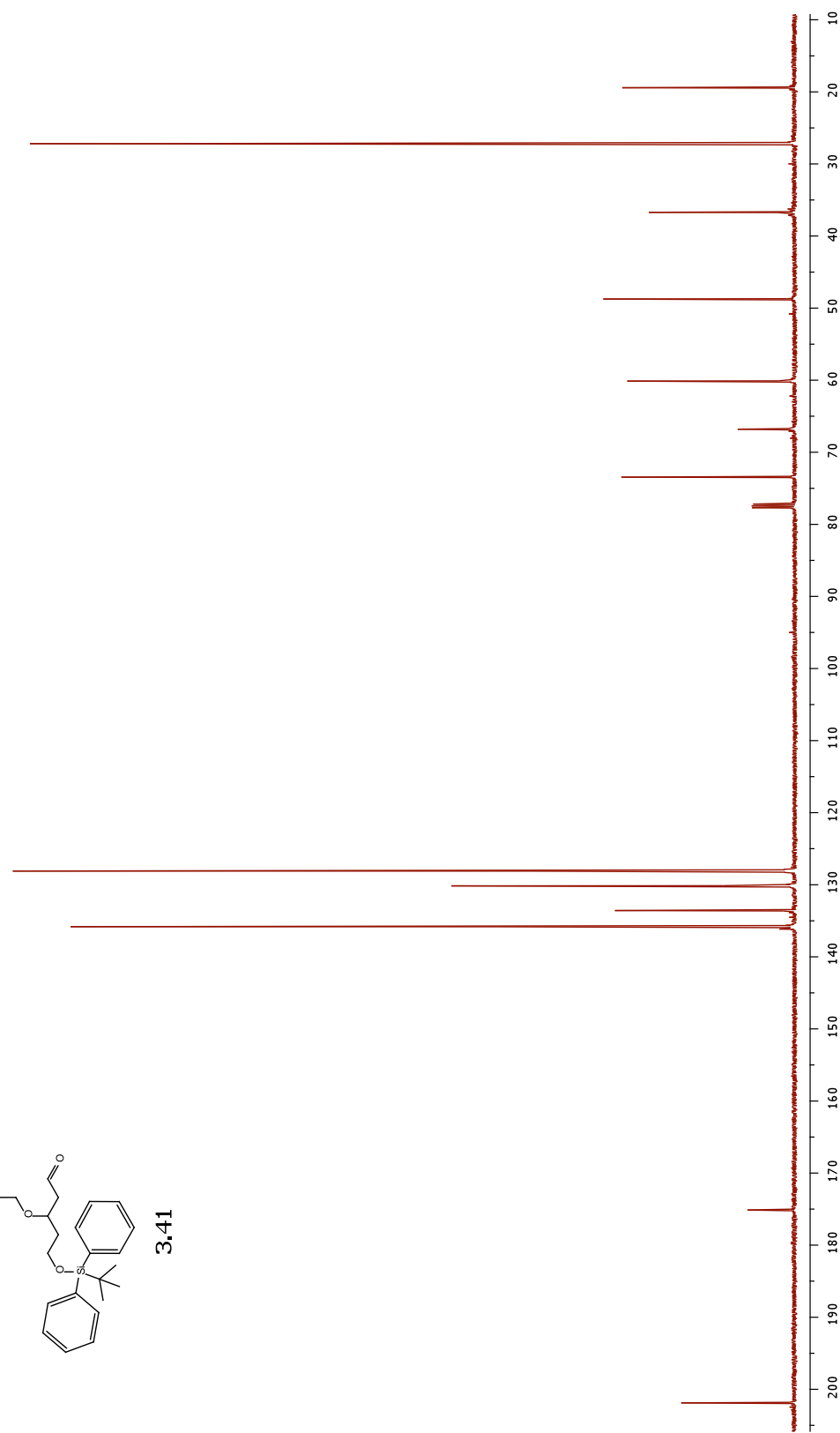


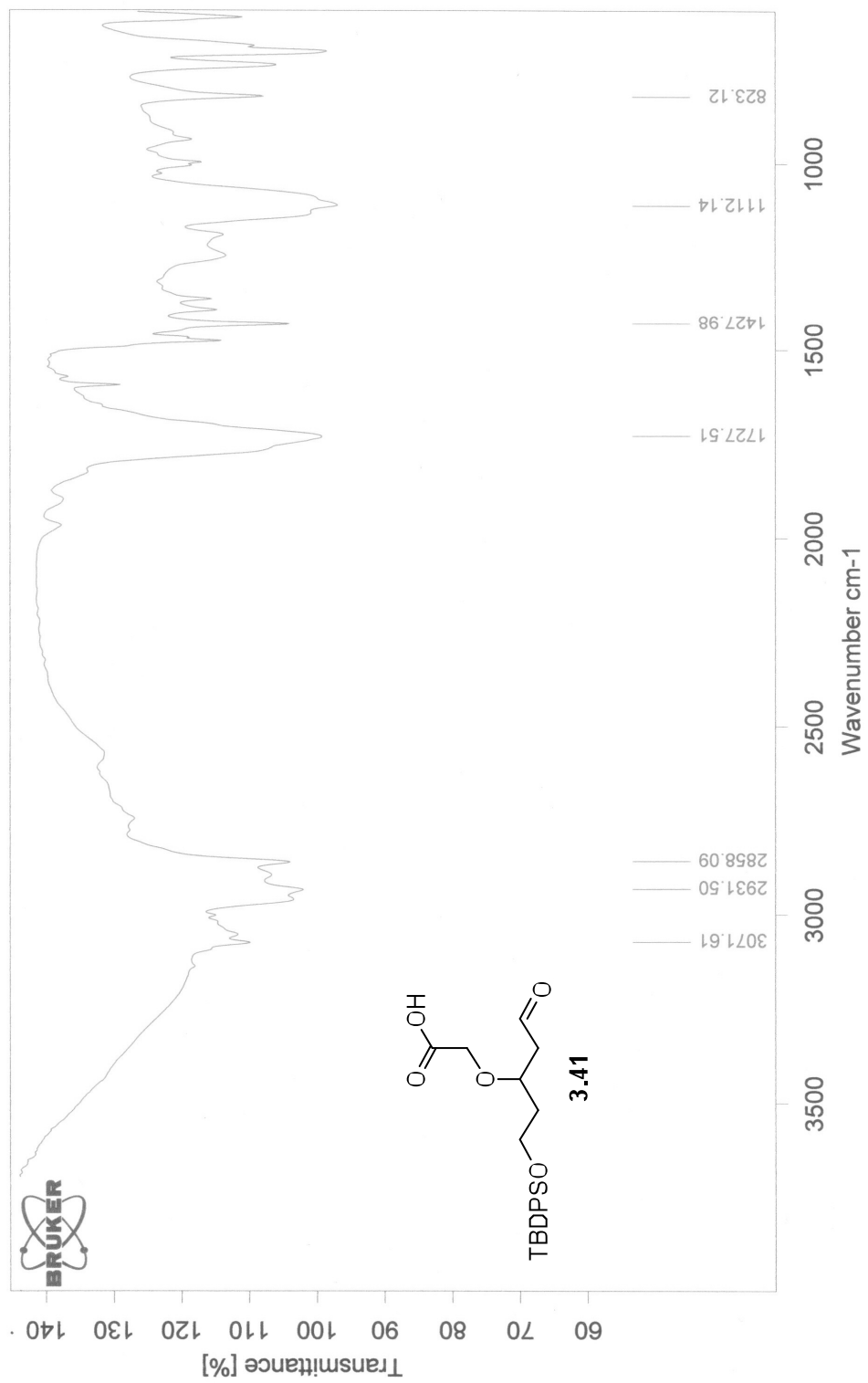
3.41



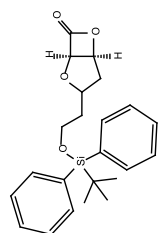


3.41

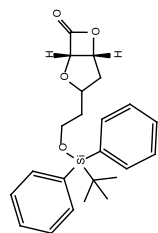




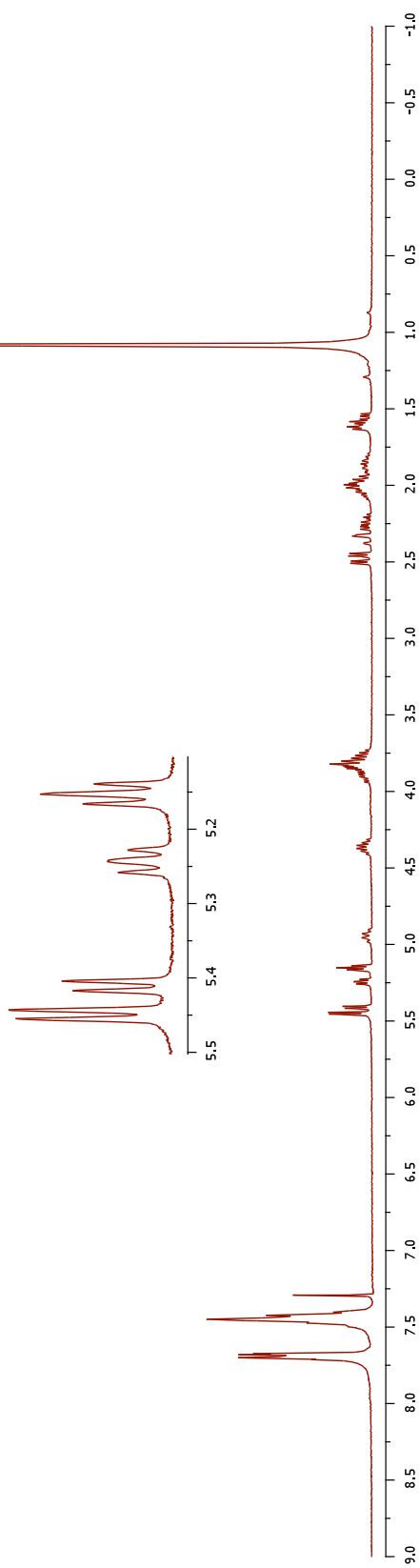


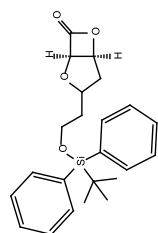


3.42b

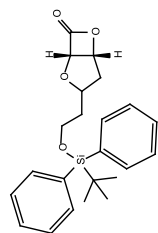


3.42a

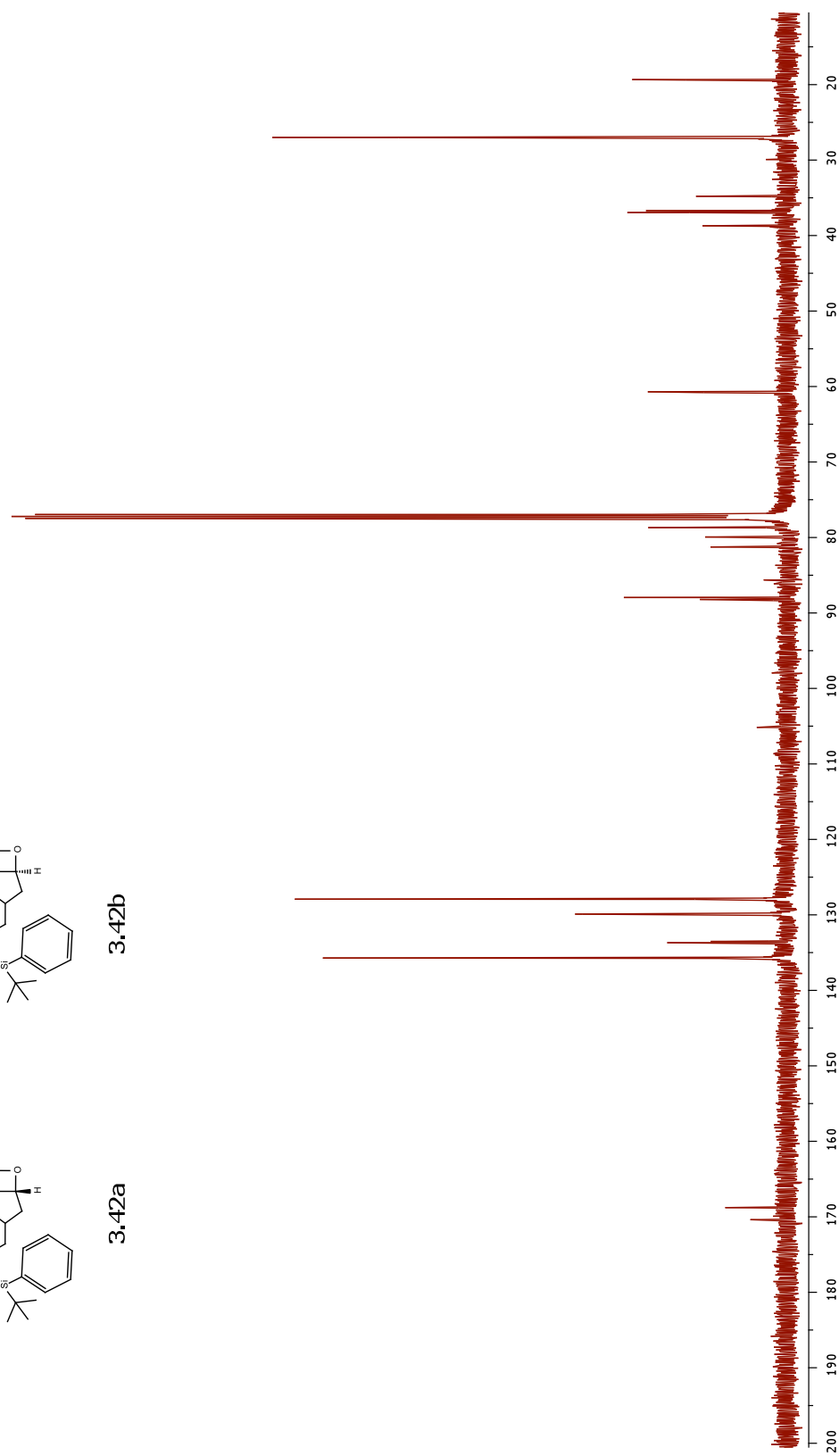


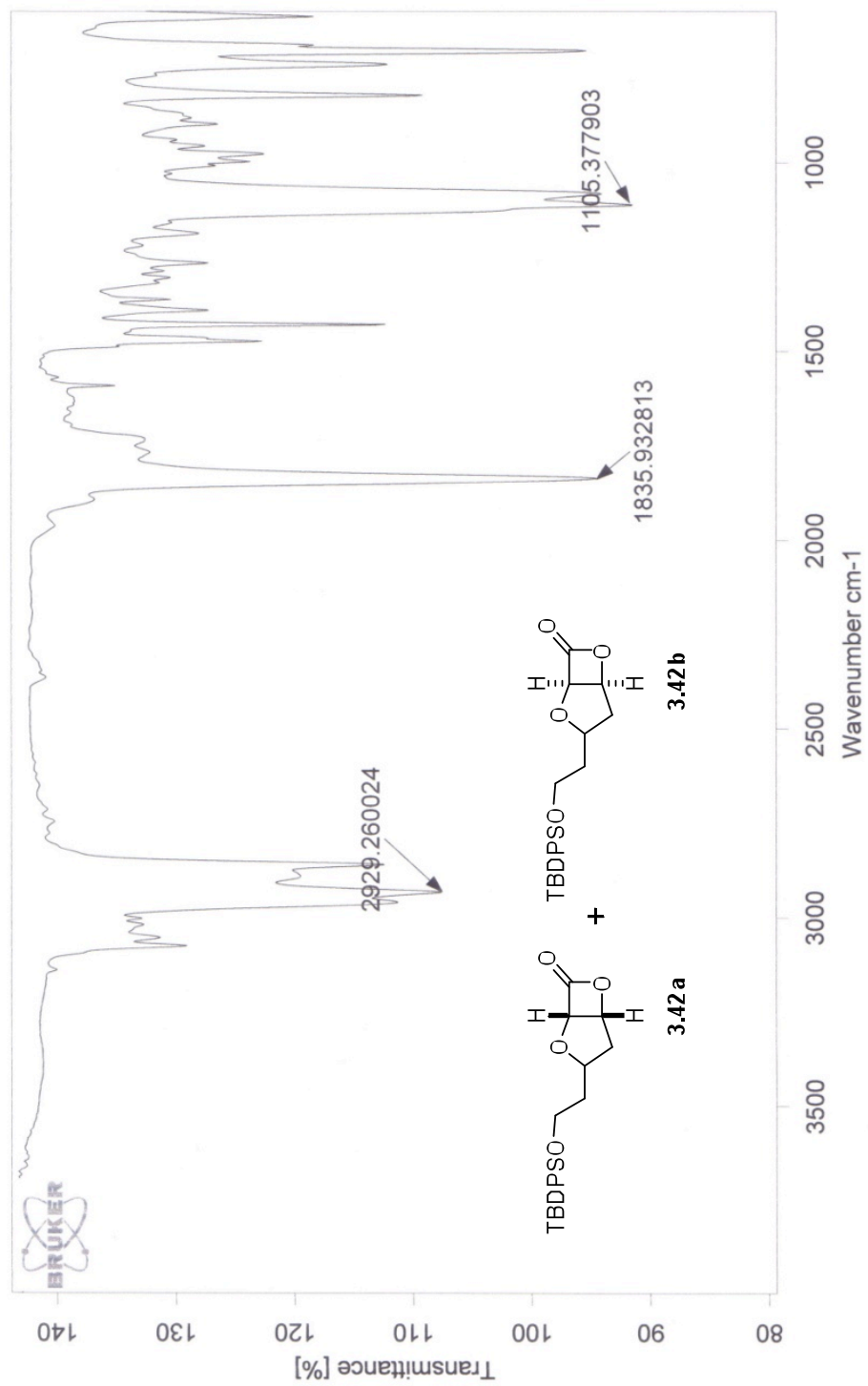


3.42b



3.42a





**CONTACT INFORMATION**

Name: Kevin Michael Arendt

Professional Address: c/o Dr. Daniel Romo  
Department of Chemistry  
P.O. Box 30012  
Texas A&M University  
College Station, TX 77842-3012

Email Address: karendt04@tamu.edu

Education: B.S. Chemistry, Texas A&M University, May 2010  
Undergraduate Research Scholar  
Phi Eta Sigma  
Phi Lambda Upsilon  
National Scholars Honor Society  
University of Texas Southwestern Medical Center  
Research Fellow