

***DEVELOPMENT OF A DEVICE FOR THE MEASUREMENT OF
BIOLOGICAL TISSUE OPTICAL PROPERTIES USING THE SINGLE
MONTE CARLO METHOD***

A Senior Thesis

By

Travis Henry Bendele

1997-98 University Undergraduate Research Fellow

Texas A&M University

Group: Engineering II

DEVELOPMENT OF A DEVICE FOR THE
MEASUREMENT OF BIOLOGICAL TISSUE OPTICAL
PROPERTIES USING THE SINGLE MONTE CARLO METHOD

by

TRAVIS HENRY BENDELE

Submitted to the
Office of Honors Programs and Academic Scholarships
Texas A&M University
in partial fulfillment of the requirements for

1997-98 UNIVERSITY UNDERGRADUATE RESEARCH FELLOWS PROGRAM

April 16, 1998

Approved as to style and content by:



Lihong V. Wang (Faculty Advisor)
Biomedical Engineering Program

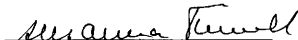

Susanna Finnell, Executive Director
Honors Programs and Academic Scholarships

Fellows Group: Engineering II

Abstract

A honeycomb probe was designed to measure the optical properties of biological tissues using single Monte Carlo method. The ongoing project is intended to be a multi-wavelength, real time, and in-vivo technique to detect breast cancer. Preliminary experiments using a larger probe showed good reduced scattering coefficient agreement. Further experiments will be performed to improve on the honeycomb probe design based on the range of parameters intended to be measured.

1. Introduction

There is currently a need for a system that will provide a real-time, *in vivo*, minimally invasive measurement of the optical properties of soft tissues. Optical properties of tissues can be used to determine metabolic status, diagnose disease, and possibly detect cancer.(Jacquez, Sevich Chance *et al*) Therefore, such a system would enable physicians to make immediate determinations about a patient's status rather than waiting on test results. The focus of this ongoing study is the development of a system for obtaining the properties of biological tissues. Specifically, the absorption coefficient, μ_a , and the reduced scattering coefficient, μ_s' are the optical properties being measured. From these two measurements, a physician will be able to diagnose the condition of the tissue in question. Two specific applications of the device presented in this paper are burn depth assessment and breast cancer diagnosis. Burn depth can be determined by finding the depth at which the optical properties of the surrounding tissue change from those of dead (oxygen-depleted) tissue to those of living (oxygen-rich) blood. It is also expected that breast cancer tumors will have sufficiently distinct optical properties to allow diagnosis of suspicious lumps by this method. In each case, the device designed in this study will penetrate the skin to make the measurement without the need to remove and biopsy the tissue. The goal is to reduce pain, cost, time, and incorrect diagnoses and treatments.

The needle-like probe is thin enough that tissue damage from the measurement process will be minimal. Optical fibers within the probe carry light to and from the tissue to be analyzed by a computer, which, in turn, calculates the optical properties. The challenge in designing the probe is to balance the theoretical requirements with the need to keep the probe as small as possible. Because the method and the software are still experimental, it is difficult to determine the most efficient physical parameters of the probe.

2. Materials and Methods

A. Theory

In principle, light that has passed through a medium inherently carries information about that medium. It follows, then that if light is shone into tissue, the diffuse reflected light will contain information about that tissue's optical properties. Monte Carlo simulations are held as the gold standard for modeling light transport in media. However, this method requires hours of computation time and is inefficient for real time measurements. The technique of single Monte

Carlo method can be many times faster and can be used in real time experiments. The Monte Carlo method (Wang *et al* 1995) has become a widely used method of numerically solving the transport equation, but it is too slow to use in an iterative algorithm where the optical properties are estimated by comparison of simulation results with actual measurements.[5] However, Kienle and Patterson (1996) have shown that it is possible to use a single Monte Carlo simulation to obtain the desired results if g and n are known. This is possible because a Monte Carlo simulation for a certain g , n and μ_s can be used to calculate the desired quantities for all μ_s by applying Beer's law. Also, the results for all μ_s can be obtained by suitably scaling the outcome of a single Monte Carlo simulation, because different μ_s values change only the distances between the interaction points on the photon paths through the tissue. Determination of the optical properties of a medium with a single Monte Carlo simulation is based on the following principle: It is possible to extract from the output of one simulation, performed with certain optical parameters, the desired quantities for other optical coefficients if g and n do not change (Kienle *et al* 1996).

Using these principles, μ_s and μ_s' can be calculated by the following method: First, reflectance vs. distance, $R_{exp}(r)$ from the tissue is gathered and adjusted to a relative scale. Then a single Monte Carlo simulation is performed using reference parameters μ_{sr} , μ_{sr} , g and n . The reflectance, $R_{ref}(r)$, values obtained from this simulation will be used to find the solution to the problem. The values of μ_{sr} and μ_{sr} that are used for the Monte Carlo simulation are estimates of the expected tissue properties. $R_{ref}(r)$ is stored and copied as $R_{comp}(r)$.

R_{comp} is used for comparison with $R_{exp}(r)$. If $R_{comp}(r)$ is not acceptably close to $R_{exp}(r)$, $R_{comp}(r)$ is scaled according to the following equation: (where $b = \mu_{sc}/\mu_{sr}$)

$$R(r, \mu_{sc}, \mu_{sc}') = (\text{integral}) R_{ref}(br, t) * \exp(i((\mu_{sc}/b) - \mu_{sr}) d) \quad (1)$$

μ_{sc} and μ_{sc}' are chosen such that the values of $R_{comp}(r)$ will be closer to $R_{exp}(r)$ than the previous iteration. This iteration is carried out until $R_{comp}(r)$ is acceptably close to $R_{exp}(r)$.

The values of μ_{sc} and μ_{sc}' that brought $R_{comp}(r)$ within the acceptable error are assumed to be the values of μ_s and μ_s' that are the target of the calculations. Having obtained μ_s , μ_s' can be obtained using $\mu_s' = \mu_{sc} (1-g)$.

B. Design of the Probe

The system that obtains the measurements consists of a light source, a probe, a spectrograph, a CCD camera, and a PC. With the exception of the probe, this system has been used by Marquez and Wang (1997) to obtain measurements of optical parameters from other tissues. The probe that was used in this study had to be specially designed for use in tissues below the surface of the skin. The design criteria were as follows: The diameter must be minimal to keep pain and damage to a minimum. The probe must collect enough data points to allow for accurate application of the theory. The separation between the data points (range of r) must be large enough to allow for accurate application of the theory. The design of the first model (HCP-7 probe) is shown in figure 1. One of the fibers is used as a source fiber which delivers white light to the tissue. The other six fibers are used as collection fibers.

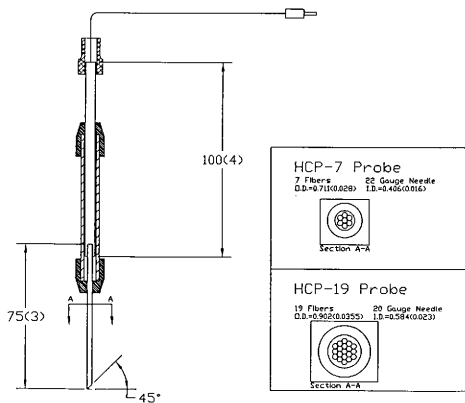

Fig 1. Schematic of HCP-7 and HCP-19.

The shaft of the probe is made of stainless steel tubing, 0.7mm outer diameter, 0.4mm inner diameter. The outer diameter is equivalent to that of a 22 gauge needle. There are seven optical fibers arranged in a hexagon. A hexagon is the most efficient arrangement of a set of round objects; this arrangement allowed for the greatest number of fibers in the least possible space. Within the probe body, the fibers were stripped to the cladding, which has a diameter of 110 μ m. If the fibers were perfectly arranged as shown, they would provide three data points across a range of 110 μ m to 220 μ m. In practice, the fiber arrangement was not so precise, and allows six data points over a range of 110 μ m to approximately 275 μ m. The current design actually uses a flat penetrating tip rather than the tapered one shown. It is not known what effect the tapering would have on the results of the measurements.

The probe is nearly 7 inches long, and a chuck was used to protect the delicate probe and improve handling. Since optical fibers have very little shear strength, there is a rubber protective piece on the handle end of the probe. The fibers are about 9 feet long and terminate in SMA's, standard connectors that are used to couple the fibers to the other equipment.

C. Fiber-Optic Probe Experiments

Future experiments will involve the following experimental technique not completed due to time constraints. The experimental system is drawn schematically in Fig. 2. White light (Oriel, 75 W Xenon Arc Lamp) will be coupled to the fiber optic probe. Approximately 4.6 mW of white light will be delivered to a tissue-simulating phantom. Although a low power light source is used, the coupling efficiency is high because of the small arc size and the collimating and focusing optics. Also, to correct for slight variations in the collection efficiency from one detection fiber to the next, a correction factor will be calculated for each fiber based on a calibration procedure using phantoms of known optical properties. The collection fibers are coupled to a connecting interface. The output of the connection interface is placed at the object plane of the imaging spectrograph.

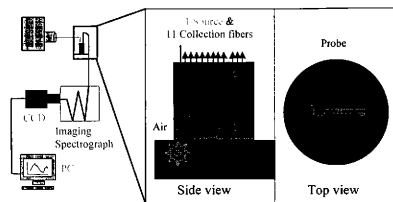

Fig. 2. Schematic of the experimental apparatus. White light was coupled to the fiber probe. A source fiber delivered light to the phantom and the diffuse reflectance was collected by 11 collection fibers. All fibers were encased to form a hand-held probe. The collected diffuse reflectance was dispersed by the spectrograph and then imaged onto the CCD matrix.

The spectrograph will spectrally disperse the 1-D light distribution and will project the image onto the CCD matrix. The vertical dimension of the image represents the spatial distribution of the diffuse reflectance. The horizontal dimension represents the spectral distribution for light from each collection fiber. The spatial distribution at each wavelength will be used to fit for the absorption and reduced scattering coefficients based on the single Monte Carlo simulation.

The detection system is composed of an imaging spectrograph (Oriel, Multispec 257), a CCD camera (Princeton Instrument Inc., 1530P), and a personal computer to automatically record the spectra of the collected white light. The imaging spectrograph is equipped with toroidal mirrors to minimize astigmatism. The CCD camera has a 512×512 pixel chip which measures 9.7×9.7 mm². With this chip size and a 150 lines/mm grating (a dispersion angle of 3.2 nm/mm), a wavelength range of 256 nm onto the CCD matrix can be imaged with spectral resolution of 0.5 nm.

A simple experiment was performed using a HeNe laser and the diffuse reflectance was collected using a power detector. The liquid phantom was composed of absorbing trypan blue dye and 0.9- μ m-diameter scattering polystyrene spheres (PS) with an expected absorption coefficient, μ_a , of 0.16 cm⁻¹ and an expected reduced scattering coefficient, μ_s' , of 6.0 cm⁻¹ at 633 nm. The probe was placed on the surface of the phantom. An exposed x-ray film was placed on top of the phantom to approximate a matched boundary condition. The absorption spectrum of

trypan blue dye was measured by collimated transmission. The reduced scattering coefficients of the polystyrene spheres were calculated using Mie Theory at multiple wavelengths.

3. Results

The needle probe was dubbed the honeycomb probe (HCP7) because its fibers were intended to be arranged in the pattern of a honey comb. For the experiments that were performed, the use of the probe was acceptable. The structural design was sturdy enough to withstand handling and no fibers were broken. The materials that were used seem to be suitable for the purpose, though some people have said that over time the super glue that surrounds the fibers will crack and pull apart. If this occurs, a new adhesive will be found.

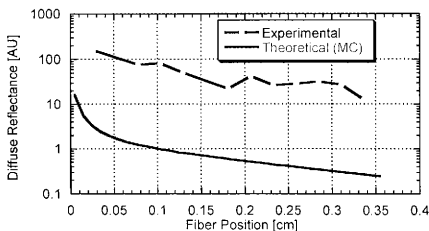

Figure 3. Comparison of Experimental and Theoretical diffuse reflectance data.

The method and software are being tested using Marquez and Wang's probe that uses a row of 12 fibers (one source, 11 collection). The method and the software are still under investigation, so it is not possible to say specifically what parameters the honeycomb probe will be most effective. A larger probe was used to measure the diffuse reflectance data of the polystyrene spheres phantom. Figure 3 shows the comparison between the experimental data and Monte Carlo data. The preliminary results using the single Monte Carlo technique show good agreement of 3% error in the reduced scattering coefficient. The absorption coefficient had a much larger error.

Finally, the greater number of collection fibers means more data points, thereby reducing the error in calculations. An alternate design for the honeycomb probe uses 19 fibers, which could yield as many as 18 data points over a range of nearly 450 μ m.

4. Discussion and Conclusions

The system still must undergo some modification before it will be ready for clinical trials. When the method, software, and probe have been refined and proven in lab and in experimental animals clinical trials can be performed to test for usability, reliability, and effectiveness. The project still shows a great deal of promise and it will be continued by Dr. Wang and his associates.

Improvements must first be made in the software which will be required to test the honeycomb probe. These improvements will come about as a result of tests using a probe that is known to work. Once the software and method are proven, the probe can be redesigned. The minimum requirements of the number and range of data points have yet to be determined. The use of other probes with the developed software will show the limitations of the system that will in turn determine the size and shape of the probe. It is expected that the probe will be expanded to have at least 19 fibers if the honeycomb design is kept. For certain applications, e.g. burn depth assessment, the system will eventually require a method of determining the depth of penetration at the time that the measurements are taken.

The current ideas for uses of the system with the honeycomb probe include breast cancer diagnosis and burn depth assessment. However, the uses of this system are by no means limited to these two procedures. An idea related to the diagnosis of breast cancer deals with the treatment of lesions with laser therapy. The honeycomb probe would be used to monitor the properties of the lesion as it is heated with a laser. The excessive heat kills the cancerous tissue, denaturing proteins and changing optical properties in the process. By monitoring the changing properties with a real-time system, the physician can stop the laser therapy when the lesion has been heated sufficiently to kill the cancerous tissue.

In general, the measurement of the optical properties of a medium has many uses in the analysis of that medium. This is especially true in the medical field where diagnoses and treatments so often begin with the appearance of the tissue in question. As the appearance of tissue changes, the optical properties necessarily change as well, so the measurement of those properties can provide significant, even life-saving, information about the condition of the tissue.

References

- Jacques S. L. , eds., *Laser-Tissue Interaction VIII*, Proc. SPIE **2975** (SPIE Press, Bellingham, WA, 1997).
- Kienle A. and Patterson M. S. 1996 Determination of the optical properties of turbid media from a single Monte Carlo simulation **41** *Phys. Med. Biol* 2221-7.
- Sevick-Muraca E. and Benaron D., eds., *OSA Trends in Optics and Photonics on Biomedical Optical Spectroscopy and Diagnostics* (Optical Society of America, Washington, DC, 1996).
- Chance B. and Alfano R. R., eds., *Optical Tomography and Spectroscopy of Tissue: Theory, Instrumentation, Model, and Human Studies II*, Proc. SPIE **2979** (SPIE Press, Bellingham, WA, 1997).
- Wang L, Jacques S. and Zheng L 1995 MCML-Monte Carlo modeling of light transport in multilayered tissues *Compt. Methods Prog. Biomed* **47** 131-46.