

## MICROCONTROLLER SERVO MOTOR FOR MAXIMUM EFFECTIVE POWER POINT FOR SOLAR CELL SYSTEM

**Dr. Osama Y. Mahmood Al-rawi**

Assit. Professor  
Email: [ovm.rawi@yahoo.com](mailto:ovm.rawi@yahoo.com)  
[dr.osama.alrawi@gulfuniversity.net](mailto:dr.osama.alrawi@gulfuniversity.net)

**Dr. Mohammed Majid Mohammed Al-Khalidy**

Assit. Professor  
Email: [drenmoh@yahoo.com](mailto:drenmoh@yahoo.com)  
[dr.mohammed.majid@gulfuniversity.net](mailto:dr.mohammed.majid@gulfuniversity.net)

Gulf University  
Electrical and Electronics Engineering College  
Kingdom of Bahrain

**Dr. Noaman M. Noaman**

Assoc. Professor  
Email: [noaman961@gmail.com](mailto:noaman961@gmail.com)  
[dr.noaman@gulfuniversity.net](mailto:dr.noaman@gulfuniversity.net)

### ABSTRACT

In this paper a Maximum Power point (MPP) tracking algorithm is developed using dual-axis servomotor feedback tracking control system. An efficient and accurate servomotor system is used to increase the system efficiency and reduces the solar cell system coast. The proposed automatic servo control system based on PIC microcontroller which is used to control the photovoltaic (PV) modules. This servo system will track the sun rays in order to get MPP during the day using direct radiation. A photo cell is used to sense the direct sun radiation and feedback a signal to the PIC microcontroller, and then the decisions are made through the microcontroller and send a command to the servomotor system to achieve maximum power generation. The proposed system is demonstrated through simulation results. Finally, using the proposed system based on PIC microcontroller, the system will be more efficient, minimum cost, and maximum power transfer is obtained.

### 1. INTRODUCTION

Many researches were conducted to develop some methods to increase the efficiency of Photovoltaic systems (solar panels).

The PV generator exhibits a nonlinear Volte-Ampere characteristic, and its maximum power point (MPP) varies with the solar insolation and temperature [1-3]. At a particular solar insolation, there is a unique operating point of the PV generator in which its power output will be in maximum. Therefore, for maximum utilization efficiency, it is necessary to match the PV generator to the load such that the equilibrium operating point coincides with the MPP of the PV source [3]. However, since the MPP varies with insolation and seasons, it is difficult

to maintain MPP operation at all solar isolations. To overcome this problem, a microcontroller servomotor system will be used to obtain maximum peak power tracking point is developed in this paper.

During the day there is a big variation of the solar cells power especially in the first six hours and last five hours of the day. For this reason it is desired to increase the cell panel in order to increase the power. So that, the system cost will be increased [4]. The output power produced by high-concentration solar thermal and photovoltaic (PV) systems is directly related to the amount of solar energy acquired by the system, and it is therefore necessary to track the sun's position with a high degree of accuracy. The photovoltaic modules work by converting sunlight directly into electricity as illustrated in Figure 1.[3].

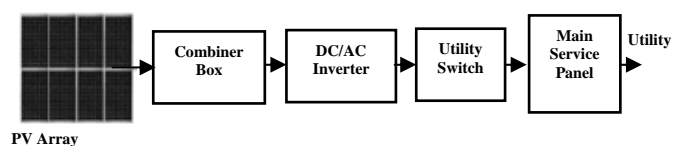

**Figure 1. Simple PV System Diagram**

The problem is that the Sun constantly moves being related to the static PV module. Actually, the apparent motion of the Sun is due, to the Earth's motion, but for our purpose here this celestial fact is mere trivia. The daily motion from East to West is called the solar azimuth. The apparent height of the Sun in the sky also changes it self being related to the change of the season from winter to summer. The yearly North to South solar motion is called solar declination [5, 6].

The Dual-axis positioning systems use both East-West and South-North axes for positioning the solar panel [6]. During a year, the dual axis system will

produce the most amount of power, because one can follow the changing of the Sun trajectory every season. At the same time, this structure is more expensive than the single-axis positioning systems, and it is more complicated for being designed, constructed and maintained [4]. The closed-loop system is based on control for sun tracking MPP [7, 8]. In such systems, a number of inputs are transferred to a microcontroller from the sensors through the feedback which detect relevant parameters induced by the sun, manipulated in the microcontroller and then yield desired position.

## 2. PV POSITION CONTROL SYSTEM

A PV position control system illustrated in Figure 2 used for orienting a solar photovoltaic panel toward the sun. PV position control system can increase the effectiveness of such system over any fixed position. A high degree of accuracy of the PV position control system is to ensure that the concentrated sunlight is directed precisely to the PV panel. The PV panel is adjusted according to the difference between the desired and the actual panel position. The microcontroller output which is the actuating signal is applied to the driving circuit which drives the servomotor in order to maintain the panel in the desired position that enable the photo sensors to receive a maximum power.

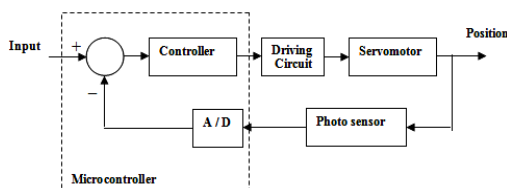

Figure 2. PV Panel Position Control System

## 3. MICROCONTROLLER TRACKING SYSTEM

Development of solar panel tracking systems has been ongoing for several years now. This paper deals with a Microcontroller based solar panel tracking system. Solar tracking system enables more energy to be generated because the solar panel is always able to maintain a perpendicular profile to the sun's rays. As the sun moves across the sky during the day, it is advantageous to have the solar panels to track the location of the sun, such that the panels are always perpendicular to the solar energy radiated by the sun. This will tend to maximize the amount of power absorbed by PV systems. It has been estimated that the use of a tracking system, over a fixed system, can increase the power output by 30% - 60% [5-8]. The power increasing is significant enough to make tracking a viable proposition despite of the enhancement in system cost.

So that the design requirements are:

- 1) During the time that the sun is up, the system must follow the sun's position in the sky.
- 2) This must be done with an active control, timed movements are useful. It should be totally automatic and simple to operate.

The reference or initial declination angle is assumed to be equal 45 deg., as well as the reference or initial azimuth angle is assumed to be equal 0 deg. (at the direction of sun rise to the East). During the day the microcontroller will compare the timer reading and the sensors outputs for both azimuth and declination. Therefore the microcontroller will send signals to both servomotors to correct the position and achieving MPP. However, if all the sensors shown in Figure 3, gives low output voltage (dark), This happen when the sun reaches the sunset time. The microcontroller will check the timer and it will compare the timer reading with the real time sunset expected. After that the microcontroller make a decision and send a command to both servomotors (the azimuth and declination motors) to go back again to the initial starting points (angles). However internal timer will be used by the microcontroller to be sure if it is a day or night time. There is a problem in the case of cloudy or dusty atmosphere during the day. This situation is determined by the Microcontroller so that the sensor output is low during the day but the presence of the internal timer can solve the problem. In such case the Microcontroller will determine precisely this situation to decide and to overcome the problem.

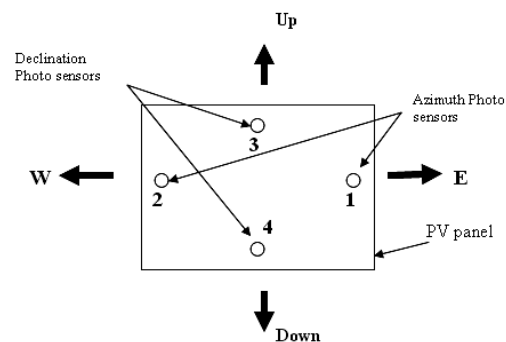

Figure 3. Photovoltaic Panel with Sensors

The circuit diagram of the microcontroller servomotor tracking system is illustrated in Figure 4. The type of microcontroller used in this circuit is PIC16F873. This type of microcontroller has five ADC, and it is used to read the analog signal of the cadmium sulfide (CdS) photocells, the photocell sensors are used to measure light intensity as shown in Figure 4. The two horizontal CdS 1&2 are used for the azimuth sensing. And the two vertical CdS 3&4

are used for the declination sensing. The sensors positions are illustrated in Figure 3.

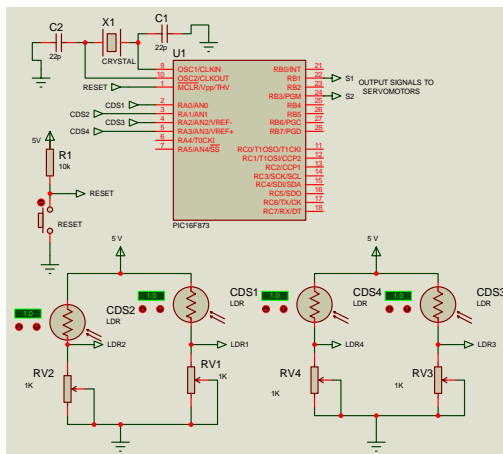

Figure 4. Microcontroller Tracking Circuit

Two servomotors are used to achieve maximum power point tracking system. Figure 5 shows the electronic circuit diagram of the servomotor's driver control. The purpose of this circuit is to achieve servomotor control in two directions. In addition bridge MOSFET transistor will be used to increase system performance. As well as the input signal of this circuit will be controlled by the microcontroller as illustrated in Figure 4.

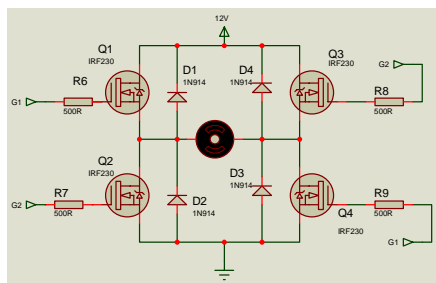

Figure 5. Servomotor Driver bridge Circuit

#### 4. CONCLUSION

The paper presents a solar tracking system with maximum power generated. The tracking controller based on the PIC Microcontroller feedback algorithm. Setups on the solar panel system, four CdS light sensitivity resistors are used to determine the solar light intensity. The proposed solar tracking system with maximum power point can track the sun light automatically. Thus, the efficiency and performance of solar energy generation can be increased. A test procedure and simulation work has been developed and carried out carefully to allow the solar tracking efficiency. The result shows that maximum power point efficiency is indeed achieved using the solar tracking system. The proposed method is verified highly beneficial to the solar maximum power point generation system.

#### REFERENCES

- [1] Yusof S.H. and M. Zamri. 2004. Modeling and Simulation of Maximum Power Point Tracker for Photovoltaic System. *Power energy Conference, PEC*, pp. 88-93.
- [2] A.W. Bett, B. Burger, F. Dimroth, G. Siefert, and H. Lerchenmüller. 2006. HIGH-CONCENTRATION PV USING III-V SOLAR CELLS. *IEEE 4th World Conference on Photovoltaic Energy Conversion, Hawaii, May 7- 12*.
- [3] Salima. K. and Achour. Betka. 2009. Efficiency Model Of DC/DC PWM Converter Photovoltaic Applications. *GCREEDER 2009, Amman-Jordan, March 31st – April 2<sup>nd</sup>*.
- [4] Syafaruddin, Engin Karatepe and Takashi Hiyama. 2010. DEVELOPMENT OF REAL-TIME SIMULATOR BASED ON INTELLIGENT TECHNIQUES FOR MAXIMUM POWER POINT CONTROLLER OF PHOTOVOLTAIC SYSTEM. *International Journal of Innovative Computing, Information and Control, ICIC International c2010 ISSN 1349-4198 Volume 6, Number 4, April, pp. 1623–1642*.
- [5] Chia-Yen Lee, Po-Cheng Chou, Che-Ming Chiang, and Chiu-Feng Lin. 2009. Sun Tracking Systems: A Review. *Sensors* 9, 3875-3890; doi:10.3390/s90503875, [www.mdpi.com/journal/sensors](http://www.mdpi.com/journal/sensors).
- [6] Laurentiu A., G. MANOLEA, and F. RAVIGAN. 2006. *POSITIONING SYSTEMS FOR SOLAR PANELS PLACED IN ISOLATED AREAS*. Annals of the University of Craiova, Electrical Engineering series No. 30.
- [7] F.R. Rubio, M.G. Ortega, F. Gordillo and M. López-Martínez. 2007. Application of new control strategy for sun tracking. *Energy Conversion and Management*, Vol. 48, Issue 7, July 2007, Pages 2174-2184.
- [8] MUMMADI V., T. SENJYU, K. UEZATO. 2002. Voltage-Based Maximum Power Point Tracking Control of PV System. *IEEE Transactions on Aerospace and Electronic Systems*. VOL. 38, NO. 1 JANUARY 2002.