

**THE INVESTIGATION OF SPICES BY USE OF INSTRUMENTAL NEUTRON
ACTIVATION ANALYSIS**

A Thesis

by

JATARA ROB WISE

Submitted to the Office of Graduate Studies of
Texas A&M University
in partial fulfillment of the requirements for the degree of

MASTER OF SCIENCE

August 2008

Major Subject: Health Physics

**THE INVESTIGATION OF SPICES BY USE OF INSTRUMENTAL NEUTRON
ACTIVATION ANALYSIS**

A Thesis

by

JATARA ROB WISE

Submitted to the Office of Graduate Studies of
Texas A&M University
in partial fulfillment of the requirements for the degree of

MASTER OF SCIENCE

Approved by:

Chair of Committee,	John W. Poston, Sr.
Committee Members,	W. Dan Reece
	Bill Batchelor
Head of Department,	Raymond J. Juzaitis

August 2008

Major Subject: Health Physics

ABSTRACT

The Investigation of Spices by Use of Instrumental Neutron Activation Analysis.

(August 2008)

Jatara Rob Wise, B.S., Lamar University

Chair of Advisory Committee: Dr. John W. Poston, Sr.

The spices consumed in the U.S. diet contain many elements other than the pure spice that many assume they eat. In particular, most of these spices contain radionuclides that are absorbed from the ground soil and water that contains trace contaminants. For this research, instrumental neutron-activation analysis (INAA) was used to determine the activities of U-235 fission products in common spices. Using this information, the concentrations of natural uranium in these spices and the doses to individuals consuming the spices were calculated.

Nine spices and two standard reference materials were selected for analysis. The spices chosen were cinnamon, cumin, turmeric, oregano, thyme, cayenne, ginger, chili powder, and paprika. For comparison, NIST-certified “orchard leaves” and “spinach leaves” were used. The spices and standards were placed in polyethylene vials and heat-sealed. The samples were divided into irradiation groups of 30 seconds, 12 hours, and long irradiations of 10 to 12.8 hours. After irradiation, all samples were counted on an HPGe detector for time periods ranging between 10 minutes to 65 hours. After counting, the results were analyzed using Genie 2000 software. The Genie 2000 analysis revealed no detectable fission products for samples irradiated for 30 seconds or counted for short

times. However, long counts revealed the high-yield U-235 fission products molybdenum-99 and what appeared to be cerium-144. However, after comparing the experimental values with the calculated values, it was determined that the experimental values of Ce-144 were not credible and the focus shifted solely toward Mo-99. From Mo-99 activities, uranium content could be calculated.

Using this information, the committed dose equivalent (CDE) and the committed effective dose equivalent (CEDE) for ingestion of uranium was calculated. The CEDE values were based on an assumed ingestion of 6.5 grams of each spice per year. The doses from ingesting these spices ranged from CDE and CEDE doses of $4.31\text{E-}05$ mSv and $3.08\text{E-}06$ mSv, respectively. Based on these measurements consumption of these spices, even when combined, would not result in annual CDE or CEDE doses approaching the limits for the public of 50 mSv and 1 mSv, respectively, for a year of chronic ingestion.

DEDICATION

I would like to dedicate this work to everyone who has helped me get to where I am today. This includes my family, inspirational non-family members, and countless individuals who had the patience to spend time with me and teach me the difference between right and wrong. I would like to give loving thanks to my wife Kellum B. Wise, who has given me unwavering support and love. I would also like to thank my mother Viola Wise, my sister Monica Wise, my two nieces Zaniya and Jala, and my nephew Jeremiah. Most of all I would like to give thanks to GOD, who lends an ear to listen and understands problems that no man can.

ACKNOWLEDGEMENTS

I would like to acknowledge everyone who helped make this research possible. I would like to thank my committee, Dr. Warren Reece (member), Dr. Bill Batchelor (member), and Dr. John Poston, Sr. (chairman) for giving me the prized opportunity to study health physics at Texas A&M University. I would also like to thank Dr. Latha Vasudevan and Albert Tejerina for spending valuable time instructing and training me for various tasks.

I would also like to thank all of my professors in the Department of Nuclear Engineering at Texas A&M University for providing first-class teaching, instruction, and competence in everything associated with health physics.

NOMENCLATURE

INAA	Instrumental Neutron Activation Analysis
DDI	Daily Dietary Intake
IAEA	International Atomic Energy Agency
HPGe	High-Purity Germanium
NSC	Nuclear Science Center
NIST	National Institute of Standards and Technology
EOI	End of Irradiation

TABLE OF CONTENTS

	Page
ABSTRACT	iii
DEDICATION	v
ACKNOWLEDGEMENTS	vi
NOMENCLATURE.....	vii
TABLE OF CONTENTS	viii
LIST OF FIGURES.....	x
LIST OF TABLES	xi
CHAPTER	
I INTRODUCTION.....	1
II BACKGROUND.....	4
II.1 Instrumental neutron-activation analysis.....	4
II.2 The fission process	5
II.3 The pneumatics system and standard irradiation.....	8
II.4 High-purity germanium (HPGe) detector.....	10
II.5 Genie 2000 software.....	15
III MATERIALS AND METHODS	18
III.1 Pneumatics system samples	18
III.2 Standard irradiation samples (12.8-hours)	19
III.3 Standard irradiation samples (12-hours, 10-hours).....	20
IV RESULTS AND CONCLUSIONS.....	21
IV.1 Pneumatics system results.....	21
IV.2 Fluence rate calculations.....	22
IV.3 Uranium concentration calculations.....	23
IV.4 Dose calculations	29

	Page
IV.5 Future work	31
REFERENCES	32
APPENDIX A	33
APPENDIX B	38
APPENDIX C	50
APPENDIX D	51
APPENDIX E	52
APPENDIX F	53
VITA	54

LIST OF FIGURES

	Page
Figure 1 Yield of fission-product chains as a function of mass number	6
Figure 2 Typical pneumatics system setup	9
Figure 3 Configuration of a planar HPGe detector.....	12
Figure 4 Coaxial detector geometry	13
Figure 5 Coaxial detector cross-sections	13
Figure 6 Diagram showing the location of an HPGe detector.....	14
Figure 7 Common horizontal configuration.....	15
Figure 8 Efficiency vs. energy curve.....	17
Figure 9 Counts vs. energy.....	28

LIST OF TABLES

	Page
Table 1 Fluence rate calculations using orchard leaves samples	23
Table 2 Expected uranium activity and minimum counts calculation	25
Table 3 Uranium content for samples with Mo-99 activity	26
Table 4 Additional larger mass calculations	27
Table 5 Uranium dose	30
Table 6 Uranium dose (larger masses).....	30

CHAPTER I

INTRODUCTION

The use of spices and condiments in various foods and as medicinal remedies has been the practice since early humans gathered around rock-to-rock stricken fires for meals and healing ceremonies. It continues today as families gather around modern-day fireplaces for dinner or the application of herbal remedies for minor ailments. While most cultures use spices and condiments to season or preserve food, many people have little or no idea what is in their spice of choice. Normally, one would think everything that is in the spice is labeled on the container's list of ingredients. More in-depth thinking would reason that the spice probably contains fine particles of native soil or there may be some level of cross contamination with other spices during manufacturing, processing, and packaging. Albeit all of these are possibilities of what is in the spices we consume, there is relatively little thought given to the amount of radioactivity or the radionuclides contained in them.

The most efficient way to determine the radiological composition present in spices and condiments is by use of Instrumental Neutron-Activation Analysis (INAA). This technique has been used by some investigators to identify the radionuclides present and to quantify the radionuclide activity levels in the spices. Another method of note is the Track-Etch Method (TEM); a technique by which damage by fission products are made visible for counting through electrochemical etching.

This thesis follows the style of Health Physics.

There have been various studies in foreign countries concerning the radiological content in spices consumed in the daily dietary intake (DDI). In India, the use of spices in preparation of daily meals is prevalent. Some of the most commonly used spices are turmeric, cumin, and curry (a mixture of different seasonings to create a specific flavor or consistency). Sharma and his colleagues investigated eighteen spices and condiments common to the Indian diet. Their results revealed uranium concentrations from less than 0.3 picograms per gram (pg g^{-1}) to nearly 80 pg g^{-1} (Sharma et al. 1981).

Spice and condiments are also used for medical purposes. Some of the world's largest mineral deposits can be found in South Africa. These mineral deposits contain uranium and, therefore, the surface soil used to farm and grow food contains trace quantities of uranium. Thirty herbal remedies were collected from traditional healers and analyzed. The results showed concentrations of uranium above 40,000 parts per billion (ppb) in eight remedies and a mean uranium concentration of 15,000 ppb in the remaining herbs (Steenkamp et al. 2005). The unusually large uranium concentrations found by Steenkamp and colleagues made particularly interesting to study uranium concentration in spices found in the U.S. market.

It is well known that the earth's crust contains many naturally-occurring radionuclides and thus contributes to the natural background radiation. A small amount of this background radiation comes from man-made sources such as radioactive waste disposal, emissions from the burning of fossil fuels, nuclear power, medical uses of radiation and radioactivity, etc. Other sources of radiation that contribute to the background are cosmic rays, solar radiation, radioactivity inside the body from the food,

water, and the air we breathe, and radon gas. With all these possible sources, the question arises as to what levels of radioactivity are we consuming from the food we eat? This research is intended to focus on the levels of radionuclides present in the food we consume. More precisely, what are the levels of radionuclides in the spices and condiments commonly found in the U.S. diet? In this research, Instrumental Neutron-Activation Analysis (INAA) was used to analyze a representative group of spices commonly found in the U.S. diet. After selecting and obtaining the spices, samples were prepared for irradiation in the nuclear reactor at Texas A&M University's Nuclear Science Center (NSC). The remaining samples were irradiated, for a specified time, using the pneumatic "rabbit" system at the NSC. All of the samples were then irradiated using standard irradiation procedures. After irradiation, the samples were removed from the reactor and the gamma emission spectra analyzed using a high-purity germanium detector (HPGe) available at the NSC. After analyzing these samples, specific attention will be given to:

- The presence of high-yield fission products of the U-235 isotope, and
- The calculation of radiation doses due to ingestion of the spices.

CHAPTER II

BACKGROUND

II.1 Instrumental Neutron-Activation Analysis

Instrumental Neutron-Activation Analysis (INAA) is a sensitive analytical technique to precisely and accurately determine unknown elemental concentrations in various materials (James 2008). The concept behind INAA consists of preparing and irradiating small samples (usually milligram quantities) with thermal neutrons in a nuclear reactor to produce or activate specific radionuclides. Once irradiated, these nuclides produce characteristic gamma-rays which can be counted using a high-purity germanium (HPGe) detector. The energy of the gamma rays and their occurrence rates can be measured, leading to the identification and determination of the radionuclide activity in the sample. The measuring of the gamma-ray energy spectra is known as gamma spectroscopy and computer software is commonly used to determine the concentrations of the various elements in the sample usually in the upper range of parts per million (ppm) down to a lower limit of parts per billion (ppb) or less.

When a material is bombarded with neutrons in a nuclear reactor, a number of events can occur depending on the spectrum of neutron energies present. The most common reaction is the (n, γ) reaction for activation products, however for this research the primary interest is in the (n, f) reaction for uranium.

II.2 The Fission Process

The fission process was discovered in 1938 by Otto Hahn, Lise Meitner, and Fritz Strassmann. U-235 is one of the most studied fissile radionuclides to date. Fission into two equal fragments is by no means the most probable mode in thermal-neutron fission; quite asymmetric divisions are much more favored, the maximum fission product yields occurring at A (mass number) = 95 to $A=138$ (Friedlander et al. 1964). Half lives of these fission products range from seconds (e.g., Kr-94, 1.4 seconds) or less to very long half lives (e.g., Nd-1244, 1.3×10^{11} years) to stable nuclides (e.g., Ba-138). The fission yield of a nuclide is the fraction or the percentage of the total number of fissions which leads directly or indirectly to that nuclide.

The focus of this work will be on high-yield fission products produced in the fission of U-235 rather than activation of a particular target material. Figure 1 shows the fission product yields as a function of mass number for the thermal-neutron fission of U-235. Note that the maximum fission yield for any radionuclide is less than 10%. In addition, although all data points are not shown in this figure, there are about 300 different nuclides (most radioactive) produced in the thermal-neutron fission of U-235.

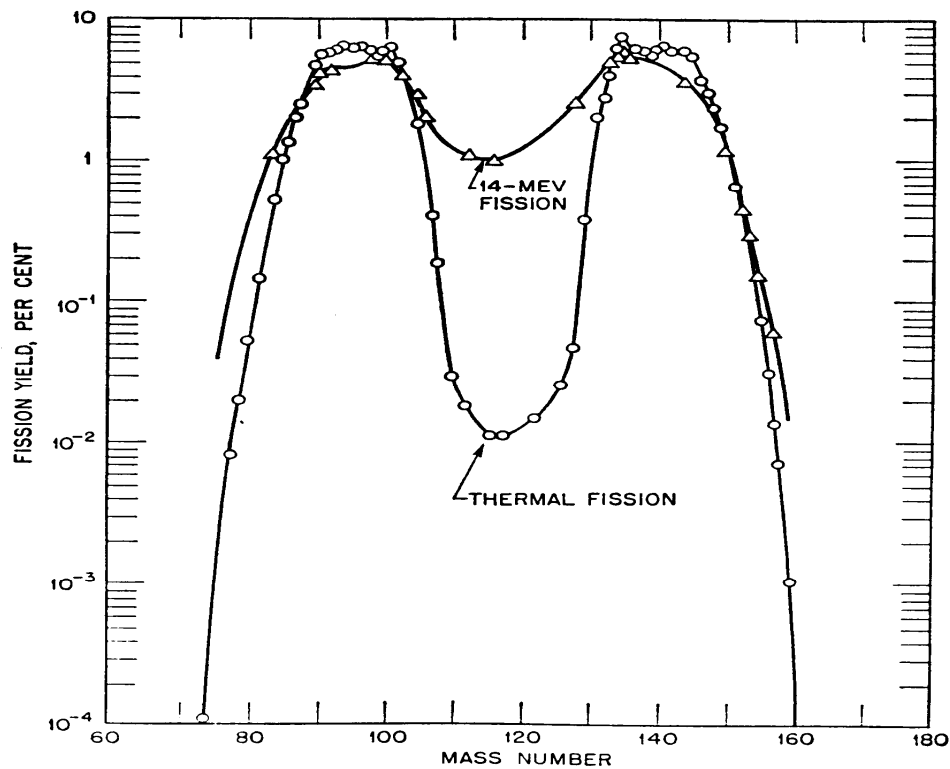

Figure 1. Yield of fission-product chains as a function of mass number.

The primary interest here was in two high-yield fission products of U-235. These two fission products were molybdenum-99 and cerium-144. The Genie 2000 software (see Chapter II.5) analyzed the information from the HPGe detector and calculated the activity or specific activity of the radionuclides in the sample generated by the software. The activity was checked by the following formula:

$$A = N\lambda_{fiss}$$

where,

A is the fission product activity,

N is the number atom of the fission product, and

λ_{fiss} is the decay constant of the fission product.

The number of atoms of the fission product, N , is given by:

$$N = (C)(m_s) \left(\frac{1}{m_{238}} \right) (Y_{235})(N_A)(\sigma_{235})(\phi)(t_{irr})(Y_{fiss})$$

where,

C is the concentration of uranium in the sample or standard,

m_s is the mass of the sample grams,

m_{238} is the atomic weight of elemental uranium,

Y_{235} is the naturally occurring fraction of the U-235 isotope,

N_A is Avogadro's number, in units of mole⁻¹

σ_{235} is the fission cross section of U-235 in barns,

ϕ is the reactor fluence rate, in units of neutrons cm⁻²s⁻¹, and

t_{irr} is the irradiation time in seconds, and

Y_{fiss} is the yield of the primary fission product.

The decay constant λ_{fiss} for a single radionuclide is defined as:

$$\lambda_{fiss} = \frac{\ln(2)}{T_{1/2}}$$

where,

$T_{1/2}$ is the half-life of the radionuclide.

With this formula induced activity from the fission of U-235 is directly related to the mass of natural uranium in the sample. Using NIST-certified standards the whole analysis process from activation to output generated by the Genie 2000 software can be checked.

II.3 The Pneumatics System and Standard Irradiation

The pneumatics system at the NSC is an elaborate system of stainless steel and polyethylene tubes that stretch from the laboratory areas to the reactor core. A sample is placed in a secure chamber and transported via a blast of carbon dioxide (CO₂) gas through the tubes into the reactor core and returned to the laboratory area after being irradiated for a pre-set time. The pneumatics system is mainly used for INAA.

When carrying out an experiment using the pneumatics system, the experimenter has access to the system through the laboratory controller by receiving a “permit” or “green light” from the control room in the reactor area. The laboratory controller allows the investigator to determine the sample irradiation time by means of a two-way intercom system between the laboratory and the control room. When the irradiation is complete, the controller provides a “return” option to return the sample to the laboratory at any time regardless of the irradiation time remaining.

Contained in the south station are two surge volumes to minimize any pressure transients when the system is in operation. Also contained in the south station are various solenoid isolation and regulating valves that supply approximately 80 pounds per square inch (psi) of CO₂ pressure to the receivers. The NSC also has a north CO₂ supply station that is similar to the south station. Both the north and south stations have “pressure adequate” system indication which will sound an alarm in the control room if the system pressure is too low for proper operation.

Before the pneumatics system can be used, the pressurized CO₂ gas supply has to be lined up for the specific laboratory that will be used in the process. A typical setup of a pneumatics system at a nuclear reactor site is shown in Figure 2.

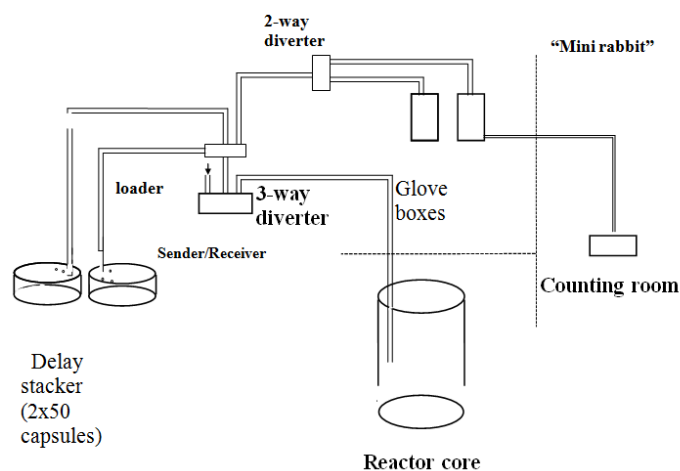

Figure 2. Typical pneumatics system setup (Baranyai 2008).

The pneumatics system is a great tool for experiments that require short irradiation times. It is commonly used as a teaching tool in graduate and undergraduate courses. For this research, the pneumatics system was used identify quickly any possible unexpected radionuclides in the samples before the standard “long tube” irradiations were done.

Standard irradiation or the “long tubes” is the most common irradiation technique at the NSC. Standard irradiation is a fairly straightforward process. First, the samples were weighted and packaged into polyethylene vials, placed in aluminum cans and

sealed. Then, the cans are placed in long tubes and lowered down near the reactor core in a specific geometric position and irradiated for periods ranging from 10 minutes to over 100 hours.

II.4 High-Purity Germanium (HPGe) Detector

For this research, INAA was used. The crux of the INAA process is measurement of the characteristic gamma rays after neutron activation. The HPGe detector at the NSC was used for the gamma-spectroscopy analysis and because the detector is so important, it is necessary to discuss HPGe characteristics.

When performing gamma-ray spectroscopy it is important to have a depletion layer or active volume that is as thick as possible since the gamma rays are extremely penetrating radiation. The thickness of the depletion region, d , is given by the following expression:

$$d = \sqrt{\frac{2\varepsilon V}{eN}}$$

where,

ε is the dielectric constant,

V is the reverse bias voltage,

e is the electronic charge, and

N is the net impurity concentration in the bulk semiconductor material.

Using silicon or germanium of normal semiconductor purity, depletion depths beyond 2 or 3 mm are difficult to achieve despite applying high bias voltages that are near the

breakdown level (Knoll 2000). The small band gap of germanium requires that an HPGe detector be operated at liquid-nitrogen temperature to reduce thermally-induced leakage currents, otherwise known as noise. Therefore, for more accurate gamma-ray spectroscopy, a more purified class of germanium is required. This more purified or ultrapure germanium is commonly known as “intrinsic” or “high-purity” germanium and detectors manufactured from this ultrapure germanium are usually called intrinsic or high-purity germanium (HPGe) detectors (Knoll 2000). While HPGe systems are operated at liquid-nitrogen temperatures to reduce noise, they can be kept at room temperature when not in use (Turner 1995). This setup makes it unnecessary to move or relocate the detector to a temperature controlled setting.

HPGe detectors have specific principal configurations required for their use. For example, large single crystals of germanium can be grown slowly from commercial volume germanium that has gone through many processes to reduce impurities to as low as 10^9 atoms per cm^3 . This is the most highly-purified germanium that currently can be produced commercially. If the remaining low-level impurities are acceptors (such as aluminum), the electrical properties of the semiconductor crystal grown from this material is mildly p-type and π -type is the designation used to represent this type of p-type material (Knoll 2000). The depletion region is normally formed at ($p^+ n$) or an ($n^+ \pi$) junction, not as an n-p junction. The two principal configurations are the planar configuration and the coaxial configuration. The planar configuration has an active volume of 10 to 30 cm^3 and the coaxial configuration has an active volume of less than

or equal to 400 cm^3 . A schematic of the planar configuration of an HPGe detector is shown in Figure 3.

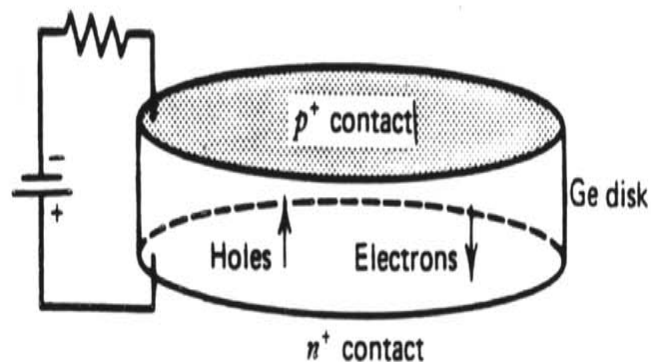

Figure 3. Configuration of a planar HPGe detector. The germanium semiconductor may be v type (p^+ contact is rectifying), π type (n^+ contact is rectifying), or lithium drifted (Knoll 2000).

As mentioned, the total active volume available in planar detectors does not exceed 10 to 30 cm^3 . To produce a detector with a large active volume needed for gamma-ray spectroscopy, a different approach is used. The large-volume detector is constructed in cylindrical or coaxial geometry as shown in Figures 4 and 5 (Knoll 2000).

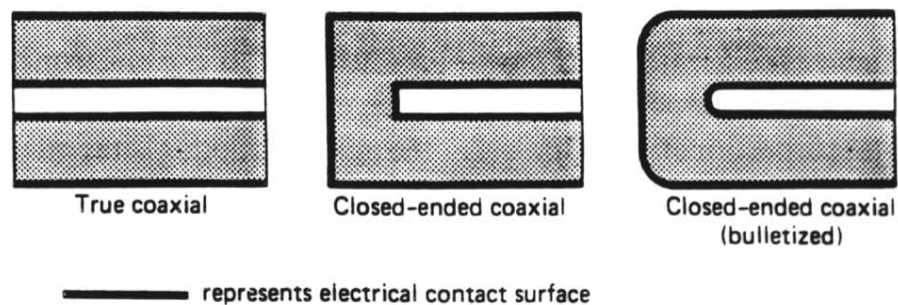

Figure 4. Coaxial detector geometry. Shown are three common shapes of large-volume coaxial detectors. Each represents a cross-sectional view through the axis of a cylindrical crystal. The outer electrode is extended over the flat front (left) surface in both closed-ended cases (Knoll 2000).

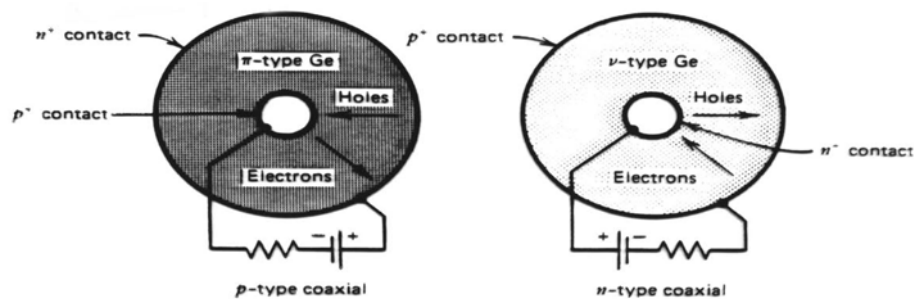

Figure 5. Coaxial detector cross-sections. The HPGe material may be either high-purity p or n-type. The corresponding electrode configurations are shown for each type (Knoll 2000).

When completely assembled, the complete HPGe detector system consists of two basic components; the detector itself and the dewar, which contains the liquid nitrogen. HPGe detectors are the ideal detectors when gamma-ray spectroscopy is required. Besides offering superior energy resolution, HPGe detectors offer reasonable precision and

accuracy along with consistency. These are the reasons the detector system was chosen for this research. Figure 6 shows a schematic cross-section of the detector and the dewar. Figure 7 shows the cryostat-detector above the liquid nitrogen dewar.

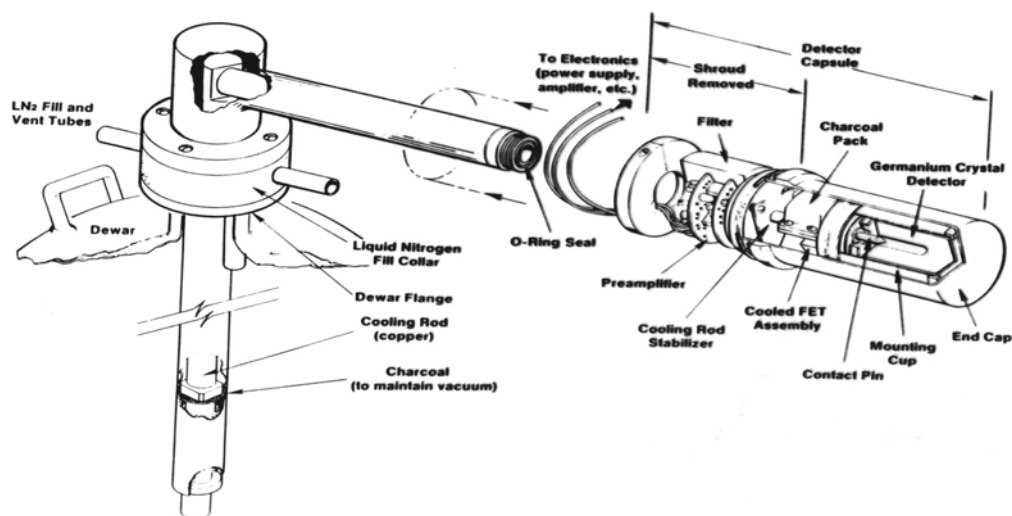

Figure 6. Diagram showing the location of an HPGe detector (Knoll 2000).

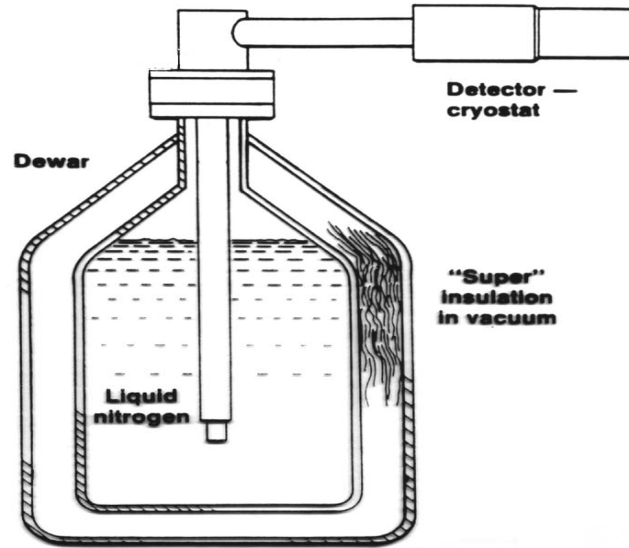

Figure 7. Common horizontal configuration (Knoll 2000).

II.5 Genie 2000 Software

The technique of neutron-activation analysis involves two basic steps, which are the actual neutron activation itself and then gamma-ray spectroscopy with the HPGe detector. Both of these are useless unless there is a way to analyze the results of the spectrum obtained using the HPGe detector. In this research, the software used for that task was Genie 2000. To identify a radionuclide, the Genie code uses matrix formalism. This formalism takes into account all peaks of a nuclide entered into the analysis library with their proper branching ratios (Genie 2000 Customization Tools Manual, 2004). At first the program builds a matrix of possible identifications by comparing each radionuclide in the analysis library against observed peaks (Genie 2000 Customization Tools Manual, 2004). Only radionuclides that meet certain criteria are accepted into the matrix (Genie 2000 Customization Tools Manual, 2004). The radionuclide will be

identified once it successfully meets the required criteria with a confidence index more than the threshold selected by the user.

For this research, once the nuclide was identified, the parameter of most interest was the activity. The Genie 2000 software reports the activity per unit mass, given in units of microcuries per gram ($\mu\text{Ci g}^{-1}$). To calculate the activity, the Genie 2000 software first identifies the radionuclide by comparing the gamma-ray energies detected against known energies in its library. The software determines the activity of the gamma ray(s) emitted by the radionuclide by matching this energy with the corresponding efficiency (ϵ) from the efficiency vs. energy curve of the HPGe detector. The efficiency is related to the activity by the following relation:

$$\epsilon = \frac{\textit{the measured count rate of a standard}}{\textit{actual decay rate of a standard}}$$

From this formula, the equation can be rearranged to find the activity. The efficiency vs. energy curve was generated via an efficiency calibration performed by the NSC staff.

Figure 8 shows efficiency vs. energy curve for NSC HPGe detector.

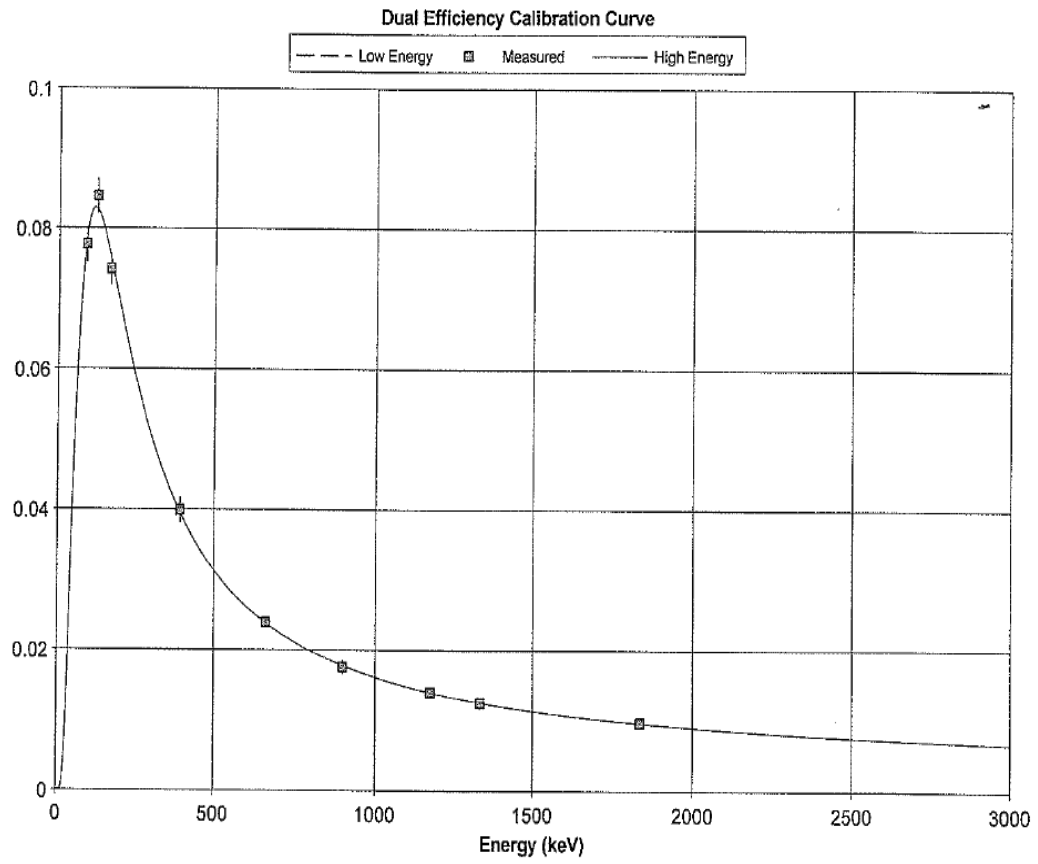

Figure 8. Efficiency vs. energy curve.

CHAPTER III

MATERIALS AND METHODS

III.1 Pneumatics System Samples

For the first analysis, cinnamon, cumin, and turmeric (all powdered) were acquired from a local supermarket. The identification labels given to the spices were K (cinnamon), C (cumin), and T (turmeric). The standard reference material used in this stage of the experiment was NIST-certified orchard leaves. These NIST-certified (see Appendix C) leaves provided a means of comparison and were identified with the label X (orchard leaves). The spices and the standard were weighed and placed into plastic vials. First, the plastic vials were weighed alone and masses recorded as M_1 . Next, the spices and standards were placed in individual plastic vials, each weighed and recorded as M_2 . By difference, the mass of the spice was recorded as mass M_3 . The experiment plan at this phase called for the spice vials to contain approximately 200 milligrams of sample and for the vials containing the standard to contain approximately 100 milligrams. After the samples were weighed and packaged, two random cinnamon, turmeric, and cumin samples were selected. In all, thirty-six vials were prepared, eight samples of each spice and twelve standards.

Individual samples were placed in tubes in the pneumatic “rabbit” system and irradiated for 30 seconds to provide a quick check to identify for surprising radionuclides. After the 30-second irradiation, the samples were counted within. The samples were counted for 10 minutes on the HPGe detector. After being counted, the

results were analyzed using the Genie 2000 software to identify the radionuclides present in the sample. The results can be found in Chapter IV.

III.2 Standard Irradiation Samples (12.8-hours)

The second stage involved a longer irradiation of the samples. After consultation with the NSC staff and knowing that a 30-second irradiation was insufficient to observe any detectable radionuclides, an irradiation time of approximately 12.8 hours was selected (this corresponded to a two shift irradiation). This group of samples was weighed and packaged in plastic vials using the exact same method as the first group of samples. These samples were also placed in three aluminum cans, put in the standard “long tubes,” and irradiated for approximately 12.8 hours. The reason for this longer irradiation time was to make any radionuclides that may be present in the spices considerably more active and, hence, make it easier to identify the radionuclides. After consultation with the NSC staff, a period of seven days was chosen to allow short-lived radionuclides to decay. The majority of the samples were counted for 10 minutes to identify any notable activation products. As expected there were no detectable fission products with this short counting time. After further discussions with the NSC staff that samples K₆, C₄, and T₃ were counted for 65 hours to reveal fission products that were not detected with a shorter 10-minute count. After analyzing the samples using the Genie 2000 software, the results were interpreted and can be found in Chapter IV.

III.3 Standard Irradiation Samples (12-hours, 10-hours)

The third stage of this research involved the selection of more spices for an even broader investigation of the spices consumed in the United States. As was done in the first stage, these spices were obtained from a local grocery store. The spices chosen were thyme, ginger, paprika, chili powder, cayenne, and oregano, all in powdered form. The standard reference material chosen for this stage was NIST-certified “trace elements in spinach leaves,” the certificate information can be found in Appendix D. The identification labels given to the spices were B (thyme), G (ginger), P (paprika), N (chili powder), E (cayenne), O (oregano), and R for the standard. These samples were weighed and packaged in vials in the same manner as for previous irradiations. In all, 48 samples were prepared, which consisted of 5 samples of each spice and 18 samples of the standard with an approximate mass of 200 milligrams for the spices and 100 milligrams for the standard. In addition to these samples, one larger sample of each spice was also prepared for irradiation. The only difference being roughly a factor of 4 increase in mass. The larger mass samples were irradiated for 10 hours and counted for 2 hours. Each spice group was placed in a separate aluminum can along with three standards and irradiated for approximately 12 hours using the long tubes. After a period of seven days had passed (to allow short-lived radionuclides to decay), one sample from each spice group was counted. The results can be found in Chapter IV. A table of the involved masses can be found the Appendix E.

CHAPTER IV

RESULTS AND CONCLUSIONS

IV. 1 Pneumatics System Results

After the samples had been packaged, irradiated, counted on the HPGe detector, and analyzed, the Genie 2000 software provides an analysis report that must be interpreted by the investigator. For this research, the primary interest was in the reported activity calculated by methods shown in part II.4 of Chapter II. When U-235 fissions, there are over 300 fission products are produced with half-lives ranging from fractions of a second to thousands of years. In addition, some of the fission products are stable (e.g. Mo-100, Nd-148, and Sm-154). For this research, the search for fission products was reduced to radionuclides that could be detected at least seven days after the EOI and radionuclides with high yields. Since all samples irradiated by standard methods were counted at least seven days after irradiation, many of the fission products had decayed away. Many other fission products were present but, the primary interest was in the fission products with high yields.

The data revealed that there were no detectable U-235 fission products for 30 second irradiations. The only radionuclides found were some (n, γ) activation products such as K-42 and some common radionuclides associated with background radiation such as K-40. An example of the Genie 2000 report for a 30-second irradiation of sample K₃ can be found in Appendix A.

IV.2 Fluence Rate Calculations

Table 1 lists samples that were irradiated for 12.8 hours and counted for 10 minutes. Here also there were no detectable fission products due to the short count time. The most common radionuclides were Fe-59 and Zn-65. In an attempt to gain confidence in the values that the Genie 2000 software provided, the reactor fluence rate was calculated (using Genie 2000 activity values) by the following formula:

$$A = (m_{std})(C_{std})(N_A)(w_{rad})^{-1}(Y_{Rad})(\sigma_{Rad})\phi(\lambda_{Rad})$$

where,

m_{std} is the mass of the standard,

C_{std} is the radionuclide concentration of the standard found on the NIST certificate,

N_A is Avagadro's constant,

w_{Rad} is the atomic weight of the radionuclide in units of grams per mole,

Y_{Rad} is the yield of the the radionuclide,

ϕ is the fluence rate at the irradiation position,

σ_{Rad} is the thermal-neutron cross section for the production of the radionuclide, and

λ_{Rad} is the decay constant of the radionuclide.

All quantities were known except the reactor fluence rate and the equation can be solved to find the reactor fluence rate, ϕ . Table 1 shows the fluence rate calculations for orchard leaves samples that were irradiated for 12.8 hours and counted for 10 minutes.

Table 1. Fluence rate calculations using orchard leaves samples.

Sample	Mass (g)	Radionuclide	Activity ($\mu\text{Ci g}^{-1}$)	ϕ (neutrons $\text{cm}^{-2}\text{s}^{-1}$)
X ₃	0.1082	Fe-59	1.5E-02	5.3E+12
		Zn-65	3.2E-02	8.5E+12
X ₅	0.1026	Fe-59	1.9E-02	6.9E+12
		Zn-65	2.8E-02	7.6E+12
X ₆	0.104	Fe-59	1.7E-02	6.4E+12
		Zn-65	2.4E-02	6.5E+12

The average neutron fluence rate based on Fe-59 activities was found to be $6.2\text{E}+12$ neutrons $\text{cm}^{-2}\text{s}^{-1}$ and the average neutron fluence rate based on Zn-65 activities was found to be $7.5\text{E}+12$ neutrons $\text{cm}^{-2}\text{s}^{-1}$. These values agree well with the actual fluence rate value of $7.1\text{E}+12$ neutrons $\text{cm}^{-2}\text{s}^{-1}$ used at the NSC for this irradiation position.

IV.3 Uranium Concentration Calculations

For samples irradiated and counted for considerably longer times, the presence of U-235 fission product(s) was expected. While it is important to know the activity of the sample, the quantity sought is content of uranium in the spice, which is usually given in parts per billion. The content can be calculated from the activities using a simple ratio formula. The known content and measured activity of the standard was related to an unknown content and experimentally calculated activity of a spice sample. The unknown content of the spice sample was calculated using the following formula:

$$m_{ratio} \left(\frac{A_{St}}{C_{St}} \right) = \left(\frac{A_{Sp}}{C_{Sp}} \right)$$

where,

m_{ratio} is the mass ratio of the standard to the sample,

C_{St} is the uranium content of the standard,

A_{St} is the activity of the standard,

C_{Sp} is the uranium content of the spice, and

A_{Sp} is the activity of the spice.

As mentioned in the Background section, the Genie 2000 software was used to determine the activity of a sample from the counts obtained using the HPGe detector. The calculated value for the activity of uranium in the NIST-certified orchard leaves is shown in Table 2. Also, the number of counts needed for the Genie 2000 software to identify the activity of the fission product is given by:

$$\textit{minimum counts} = (A)(t_c)(\epsilon)$$

where,

A is the activity of the fission product, in units of becquerel's (Bq),

t_c is the length of time the sample is counted, and

ϵ is the detector efficiency.

The expected activity of the NIST-certified orchard leaves and the minimum number of counts to see that activity for Ce-144 can be readily estimated using known information.

Table 2. Expected uranium activity and minimum counts calculation.

Parameters	Values
m_S	1 g
C	29 ng g ⁻¹
m_{238}	238.03 g mole ⁻¹
N_A	6.02E+23 mole ⁻¹
Y_{235}	0.0072
σ_{235}	5.9E-22 barns
ϕ	7.1E+12 neutrons cm ⁻² s ⁻¹
t_{irr}	46080 seconds
Y_{fiss}	0.0555
λ	2.8E-08 s ⁻¹
expected counts	541 counts
expected activity	4.3E-06 μ Ci g ⁻¹

The above calculation is for activity from the U-235 fission product Ce-144 in orchard leaves, also listed is the expected counts and the expected activity, if counted for 12 hours. However, all samples analyzed with the Genie 2000 software consistently reported Ce-144 activities on the level of 1E-03 μ Ci g⁻¹. The latter value was extremely puzzling and a number of investigations were conducted to clarify this discrepancy.

These investigations included;

- numerous and extensive recalculations
- counting the empty irradiated polyethylene vials (blanks) for uranium activity
- interference radionuclides with similar energies and half-lives as Ce-144

- high-background radiation levels in the detector room at the NSC.

After numerous recalculations, no calculation errors were found and the blanks and background contributed negligibly. The samples were also placed in new polyethylene vials and recounted. The recount confirmed earlier results, which eliminated the possibility of contamination in the vial. The background levels at the NSC were tested via an “empty count,” for which the HPGe detect remained empty (free of samples), for 12 hours to determine the background levels. The “empty count” revealed no Ce-144 or uranium background. After performing these investigations and ruling out the three aforementioned possibilities, it was concluded that the Genie 2000 software was identifying an interfering radionuclide with similar energy or there was a systematic problem with the Genie 2000 software.

A similar calculation was performed for activity of Mo-99 in spinach leaves and was found to be $2.6 \mu\text{Ci g}^{-1}$ for the spinach leaves. For Mo-99, there was better agreement between the predicted activity value and the Genie 2000 software activity value for two of the spices. Table 3 shows the uranium concentration calculated from Mo-99 activity. In Table 3, the uranium content was calculated for two samples with Mo-99 present is reasonable compared to the NIST-certified spinach leaves.

Table 3. Uranium content for samples with Mo-99 activity.

Sample	Label	m_{ratio}	$C_{\text{st}}(\text{ng g}^{-1})$	$A_{\text{st}}(\mu\text{Ci g}^{-1})$	$A_{\text{sp}}(\mu\text{Ci g}^{-1})$	$C_{\text{sp}}(\text{ng g}^{-1})$
Oregano	O ₁	1.96	155	1.41E-03	4.36E-03	245
Paprika	P ₄	2	155	1.41E-03	1.94E-03	107

These agreements lead to the decision to analyze larger mass samples to investigate Mo-99 rather than Ce-144 which was plagued with small activities. Ce-144 has a half-life of 285.9 days and Mo-99 has a half-life of 2.75 days. There was a small window of opportunity to detect Mo-99 due to its short half-life and after time passed to allow short lived activations to decay. However, the half-life of Ce-144 is less active and its half-life is 104 times longer. Normally, there would have been no problem detecting Ce-144 but due to its small activity more time would have been needed to allow short lived isotopes to decay and a considerably longer count would have been needed. Mo-99 was more active than Ce-144 which made it possible to be detected in samples counted within 7 to 8 days after Genie 2000 software activity corrects for radioactive decay, correcting to the EOI but if the nuclide has decayed to negligible levels before being counted, obviously nothing can be done.

Samples with larger masses were analyzed (see Appendix F) to further confirm the above results for uranium concentration due to Mo-99 activity. Table 4 shows the results (note that the subscript L denotes the larger masses that were used).

Table 4. Additional larger mass calculations.

Sample	Label	m_{ratio}	$C_{st}(ng\ g^{-1})$	$A_{st}(\mu Ci\ g^{-1})$	$A_{sp}(\mu Ci\ g^{-1})$	$C_{sp}(ng\ g^{-1})$
Ginger	G _L	1.706692	155	5.07E-03	1.34E-03	24
Paprika	P _L	1.707455	155	5.07E-03	1.61E-03	29
Cinnamon	K _L	2.00157	155	5.07E-03	2.48E-03	38

The Genie 2000 software initially reported the activity of the spinach leaves standard three times larger than the calculated value of $2\text{E-}3 \mu\text{Ci g}^{-1}$ after a 2 hour count. The activity was reduced to only 2.5 times larger after a longer count of 12 hours. The Genie 2000 software reports these larger values because the peaks are so small that it systematically overestimates the activities. Figure 9 shows the plot of the spinach leaves spectrum with an arrow identifying the 140.5 keV peak of Mo-99 (note the scale is counts vs. energy).

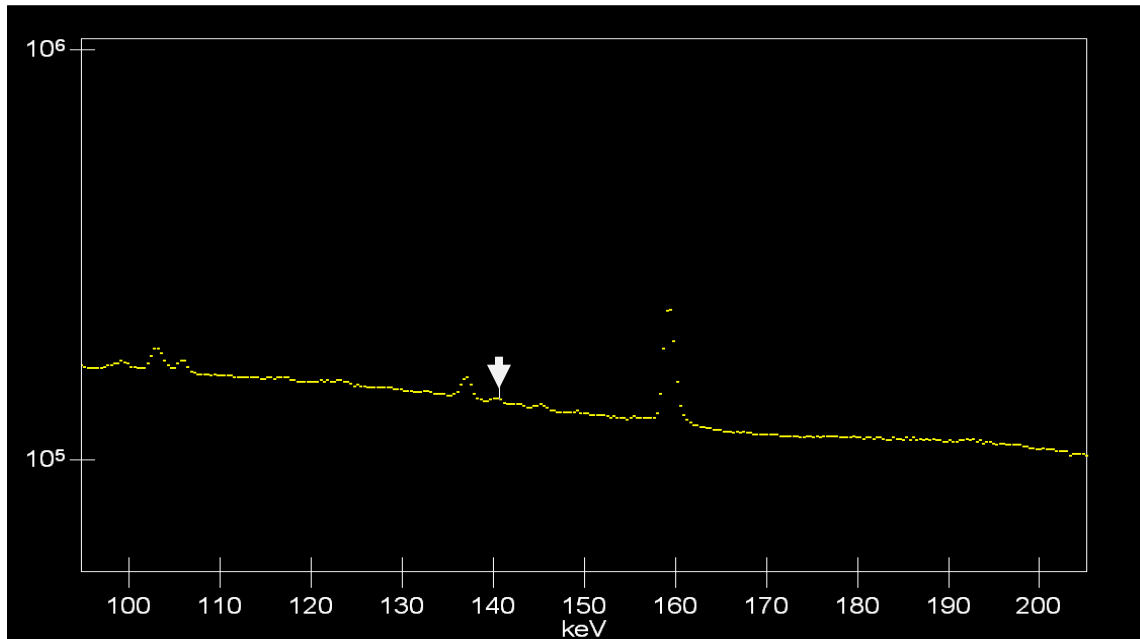

Figure 9. Counts vs. energy.

Errors of this magnitude are acceptable due to:

- if they are systematic the ratios will cancel
- the answers are so low bounding values are acceptable

- the window of opportunity is limited by the half-lives of activation products and Mo-99.

There was not much that could have been done to make the concentration levels more accurate with this method (see Future Work).

IV. 4 Dose Calculations

With the uranium content established, committed dose equivalent (CDE) and committed effective dose equivalent (CEDE) received from the consumption of the spices can be calculated. The following dose estimates were based on the consumer ingesting 6.5 grams of spice per year, inhalation of the spice was not considered. With the assumptions established, the formula used to estimate the CDE was:

$$CDE = \frac{I_{sp}}{ALI_N} \times 50 \text{ rem}$$

where,

CDE is the committed dose equivalent for ingestion,

I_{sp} is the intake of the spice, and

ALI_N is the non-stochastic annual limit on intake for uranium ($5E+05$ Bq) based on 50 rems to the bone surfaces (ICRP 1979).

The CEDE values were calculated using the following formula:

$$CEDE = \frac{I_{sp}}{ALI_S} \times 5 \text{ rem}$$

where,

CEDE is an estimate of the committed effective dose equivalent for ingestion,

I_{sp} is the intake of the spice, and

ALI_S is the stochastic annual limit on intake for uranium ($7E+05$ Bq) based on 5 rems (ICRP 1979).

Table 5 shows the CDE and CEDE values for uranium dose from spice ingestion.

Table 5. Uranium dose.

Sample	Label	CDE (mSv)	CEDE (mSv)
Oregano	O ₁	1.98E-05	1.41E-06
Paprika	P ₄	8.64E-06	6.17E-07
	Sum	2.84E-05	2.03E-06

As mentioned, additional analysis was performed on samples with larger masses. Table 6 shows the results of analysis (note that the subscript L denotes larger masses used).

Table 6. Uranium dose (larger masses).

Sample	Label	CDE (mSv)	CEDE (mSv)
Ginger	G _L	1.94E-06	1.39E-07
Paprika	P _L	2.34E-06	1.67E-07
Cinnamon	K _L	3.07E-06	2.19E-07
	Sum	7.35E-06	5.25E-07

The ALI values of $5E+05$ Bq (non-stochastic) and $7E+05$ Bq (stochastic) are taken from ICRP Publication 30. Although ICRP-30 was released in 1979, the data presented in it are still used in the U.S. Federal Regulations. In Tables 5 and 6, the summed values can be interpreted as a sum of all the combined intakes of each of the spices per year. It is obvious that the CDE and CEDE values even when combined, are well below the public annual limits 50 mSv (deterministic) and 1 mSv (stochastic). Hence, there is no apparent danger from the ingestion of these spices at the presumed mass.

IV. 5 Future Work

There are numerous ways in which this work may be advanced. For in-depth advancement, it comes down to the creativity of the investigator. For instance, the Compton suppression could be studied to maximize the signal-to-noise ratio to enable the software program to better analyze the Mo-99 spectrum information. Also very long count times could be done for more accurate identification of Ce-144.

REFERENCES

- Baranyai, Rózsa. Reactor-Neutron Activation Analysis. Budapest Neutron Center. 21 January 2008. Budapest Neutron Center. 9 May 2008
<<http://www.bnc.hu/modules.php?name=News&file=article&sid=8>>.
- Friedlander, Gerhart, and Joseph W. Kennedy, Julian M. Miller. Nuclear and Radiochemistry. 2nd. New York: Wiley & Sons, 1964.
- Genie 2000 Customization Tools Manual. Meridian, CT: Canberra Industries, Inc, 2004.
- International Committee on Radiological Protection (ICRP), Limits for Intakes of Radionuclides by Workers. ICRP Publication 30 Part 1(1979): 83-95.
- James, William. Neutron Activation Analysis. Elemental Analysis Laboratory. 01 February 2008 . Texas A&M University Department of Chemistry. 9 May 2008
<<http://www.chem.tamu.edu/services/naa/naa.htm>>.
- Knoll, Glenn. Radiation Protection and Measurement. 3rd. New York: Wiley & Sons, 2000.
- Sharma, Lal, Manesh, Nagpaul, S.K. Chakarvarti. Trace Content of Uranium in Spices and Condiments. Health Physics 41(4) (1981): 680-682.
- Steenkamp, Stewart, Chimuka, Ewa Cukrowska. Uranium Concentrations in South African Herbal Remedies. Health Physics 89(6) (2005): 678-683.
- Turner, James. Atoms, Radiation, and Radiation Protection. 2nd. New York: Wiley & Sons, 1995.

APPENDIX A

GENIE 2000 REPORT FOR 30-SECOND (10-MINUTE COUNT) IRRDIATION

```
*****
*****      G A M M A   S P E C T R U M   A N A L Y S I S      *****
*****
```

Filename: I:\CAMFILES\Jatara Wise Spice Samples\20FEB08\JW_K3_20FEB08_S

Report Generated On : 5/8/2008 11:00:53 AM

Sample Title : JW_K3_20FEB08_SH
 Sample Description : Jatara Wise Sample K3
 Sample Identification : Sample K3
 Sample Type :
 Sample Geometry : S1PS

Peak Locate Threshold : 3.00
 Peak Locate Range (in channels) : 1 - 65535
 Peak Area Range (in channels) : 1 - 65535
 Identification Energy Tolerance : 1.000 keV

Sample Size : 2.051E-001 g

Sample Taken On : 2/19/2008 4:18:00 PM
 Acquisition Started : 2/20/2008 4:00:43 PM

Live Time : 600.0 seconds
 Real Time : 602.3 seconds

Dead Time : 0.38 %

Energy Calibration Used Done On : 2/20/2008
 Efficiency Calibration Used Done On : 4/9/2007
 Efficiency ID : S1PS_newSH

 ***** P E A K A N A L Y S I S R E P O R T *****

Detector Name: SH
 Sample Title: JW_K3_20FEB08_SH
 Peak Analysis Performed on: 5/8/2008 11:00:53 AM
 Peak Analysis From Channel: 1
 Peak Analysis To Channel: 8192

Peak No.	ROI start	ROI end	Peak centroid	Energy (keV)	FWHM (keV)	Net Peak Area	Net Area Uncert.	Continuum Counts
1	854-	867	860.70	312.69	1.30	8.58E+001	27.62	2.42E+002
2	965-	971	968.84	352.17	0.93	2.25E+001	14.82	1.05E+002
3	1394-	1411	1403.03	510.66	1.62	1.94E+002	31.27	2.41E+002
4	1515-	1530	1522.63	554.32	1.39	6.70E+002	34.32	1.69E+002
5	1691-	1708	1699.76	618.98	1.43	3.78E+002	31.71	1.93E+002
6	1908-	1925	1917.08	698.31	1.63	2.64E+002	25.13	1.13E+002
7	1961-	1968	1964.29	715.55	0.65	3.75E+000	9.95	4.73E+001
8	2121-	2139	2130.95	776.38	1.63	5.83E+002	30.73	1.07E+002
9	2265-	2280	2271.59	827.72	1.93	1.64E+002	19.73	7.42E+001
10	2317-	2332	2323.54	846.69	1.47	1.78E+003	45.16	8.73E+001
11	2853-	2868	2863.87	1043.93	1.29	1.53E+002	20.41	8.74E+001
12	3604-	3621	3613.17	1317.46	1.85	1.22E+002	20.04	8.57E+001
13	3744-	3763	3752.82	1368.44	2.08	8.53E+002	32.39	5.72E+001
14	4001-	4011	4005.81	1460.79	1.49	2.66E+001	8.97	2.24E+001
15	4036-	4053	4043.70	1474.62	1.88	7.60E+001	13.53	3.30E+001
16	4169-	4191	4180.35	1524.50	1.97	2.13E+003	47.10	2.32E+001
17	4740-	4754	4746.74	1731.26	2.08	4.68E+001	8.91	1.12E+001
18	4954-	4971	4963.68	1810.45	2.27	1.98E+002	16.23	2.02E+001
19	5782-	5801	5791.76	2112.74	1.80	1.06E+002	12.20	1.24E+001
20	7535-	7557	7546.72	2753.38	2.50	4.44E+002	22.13	1.16E+001

M = First peak in a multiplet region

m = Other peak in a multiplet region

F = Fitted singlet

Errors quoted at 1.000 sigma

 ***** N U C L I D E I D E N T I F I C A T I O N R E P O R T *****

Sample Title: JW_K3_20FEB08_SH
 Nuclide Library Used: C:\GENIE2K\CAMFILES\STDLIB.NLB

..... IDENTIFIED NUCLIDES

Nuclide Name	Id Confidence	Energy (keV)	Yield (%)	Activity (uCi/g)	Activity Uncertainty
NA-24	0.954	1368.53*	100.00	4.94100E-002	2.10936E-003
		2754.03*	99.94	3.94906E-002	9.00091E-003
K-40	1.000	1460.81*	10.67	5.08754E-003	1.71792E-003
K-42	0.978	1524.67*	17.90	9.52912E-001	2.80745E-002
MN-56	0.653	846.75*	98.90	1.35402E+001	4.24315E-001
		1810.69*	27.20	1.04937E+001	9.49101E-001
		2113.05*	14.30	1.17629E+001	1.56459E+000
BR-82	0.966	221.45	2.26		
		554.32*	70.60	1.27480E-002	7.05622E-004
		606.30	1.17		
		619.07*	43.10	1.30573E-002	1.13096E-003
		698.33*	28.20	1.56363E-002	1.52195E-003
		776.49*	83.31	1.28899E-002	7.25593E-004
		827.81*	24.20	1.32316E-002	1.61290E-003
		1007.57	1.27		
		1043.97*	27.30	1.35402E-002	1.82347E-003
		1317.47*	26.90	1.35573E-002	2.23485E-003
1474.82*	16.58	1.50363E-002	2.69069E-003		

* = Energy line found in the spectrum.

@ = Energy line not used for Weighted Mean Activity

Energy Tolerance : 1.000 keV

Nuclide confidence index threshold = 0.30

Errors quoted at 1.000 sigma

 ***** I N T E R F E R E N C E C O R R E C T E D R E P O R T *****

Nuclide Name	Nuclide Id Confidence	Wt mean Activity (uCi/g)	Wt mean Activity Uncertainty
NA-24	0.954	4.889583E-002	2.054122E-003
K-40	1.000	5.087538E-003	1.717922E-003
K-42	0.978	9.529120E-001	2.807451E-002
MN-56	0.653	1.296028E+001	3.761637E-001
BR-82	0.966	1.318099E-002	4.034081E-004

? = nuclide is part of an undetermined solution
 X = nuclide rejected by the interference analysis
 @ = nuclide contains energy lines not used in Weighted Mean Activity

Errors quoted at 1.000 sigma

Interference Corrected Activity Report 5/8/2008 11:00:54 AM Page 5

***** U N I D E N T I F I E D P E A K S *****

Peak Locate Performed on: 5/8/2008 11:00:53 AM
 Peak Locate From Channel: 1
 Peak Locate To Channel: 8192

Peak No.	Energy (keV)	Peak Size in Counts per Second	Peak CPS % Uncertainty	Peak Type	Tol. Nuclide
1	312.69	1.4295E-001	32.21		
2	352.17	3.7477E-002	65.92	Tol.	PB-214
3	510.66	3.2356E-001	16.11	Tol.	BR-80
7	715.55	6.2500E-003	265.44		
17	1731.26	7.7931E-002	19.05	D-Esc.	

M = First peak in a multiplet region
 m = Other peak in a multiplet region
 F = Fitted singlet

Errors quoted at 1.000 sigma

APPENDIX B

GENIE 2000 REPORT FOR A 12-HOUR (12-HOUR COUNT) IRRADIATION

```
*****  
*****      G A M M A   S P E C T R U M   A N A L Y S I S      *****  
*****
```

Filename: I:\CAMFILES\Jatara Wise Spice Samples\RFS08-109\JW_15APR08_SH

Report Generated On : 5/8/2008 11:17:03 AM

Sample Title : JW_15APR08_SH
Sample Description : O1 Oregano
Sample Identification : O1
Sample Type :
Sample Geometry : S1PS

Peak Locate Threshold : 3.00
Peak Locate Range (in channels) : 1 - 65535
Peak Area Range (in channels) : 1 - 65535
Identification Energy Tolerance : 1.000 keV

Sample Size : 2.127E-001 g

Sample Taken On : 4/7/2008 9:06:00 PM
Acquisition Started : 4/15/2008 4:57:01 PM

Live Time : 43200.0 seconds
Real Time : 44020.8 seconds

Dead Time : 1.86 %

Energy Calibration Used Done On : 4/15/2008
Efficiency Calibration Used Done On : 4/3/2008
Efficiency ID : S1PS

 ***** P E A K A N A L Y S I S R E P O R T *****

Detector Name: SH
 Sample Title: JW_15APR08_SH
 Peak Analysis Performed on: 5/8/2008 11:17:03 AM
 Peak Analysis From Channel: 1
 Peak Analysis To Channel: 8192

	Peak No.	ROI start	ROI end	Peak centroid	Energy (keV)	FWHM (keV)	Net Peak Area	Net Area Uncert.	Continuum Counts
M	1	154-	212	159.95	57.16	1.26	1.24E+004	460.93	3.57E+005
m	2	154-	212	164.40	58.79	1.26	1.43E+004	461.11	3.59E+005
m	3	154-	212	170.01	60.84	1.26	9.63E+003	444.33	3.61E+005
m	4	154-	212	174.74	62.57	1.27	1.78E+004	458.42	3.33E+005
m	5	154-	212	181.22	64.94	1.27	4.88E+003	428.99	3.67E+005
m	6	154-	212	186.84	66.99	1.28	1.45E+004	445.36	3.69E+005
m	7	154-	212	192.85	69.19	1.28	3.65E+004	498.80	3.73E+005
m	8	154-	212	201.43	72.33	1.29	9.21E+003	451.44	3.76E+005
m	9	154-	212	207.65	74.60	1.29	1.54E+004	472.55	3.79E+005
M	10	228-	347	234.39	84.38	1.21	8.32E+003	430.51	3.40E+005
m	11	228-	347	240.18	86.50	1.22	9.79E+003	440.60	3.66E+005
m	12	228-	347	254.23	91.63	1.23	2.37E+004	457.90	3.55E+005
m	13	228-	347	261.66	94.35	1.23	2.05E+004	443.84	3.20E+005
m	14	228-	347	272.31	98.24	1.24	3.82E+004	445.74	3.40E+005
m	15	228-	347	285.16	102.94	1.25	3.20E+005	735.76	3.26E+005
m	16	228-	347	292.96	105.79	1.25	2.42E+004	421.39	3.16E+005
m	17	228-	347	304.53	110.02	1.26	1.15E+004	399.21	2.82E+005
m	18	228-	347	312.89	113.08	1.26	2.46E+004	416.62	3.02E+005
m	19	228-	347	322.83	116.72	1.27	7.77E+003	393.85	2.95E+005
m	20	228-	347	336.04	121.54	1.27	2.21E+004	417.80	2.87E+005
m	21	228-	347	341.52	123.55	1.28	6.03E+004	469.14	2.83E+005
M	22	357-	407	360.93	130.64	1.24	4.57E+003	379.00	2.27E+005
m	23	357-	407	367.21	132.94	1.24	3.47E+004	420.82	2.69E+005
m	24	357-	407	378.13	136.93	1.25	7.71E+004	484.22	2.59E+005
m	25	357-	407	387.55	140.38	1.25	1.40E+004	371.55	2.31E+005
m	26	357-	407	393.35	142.50	1.26	5.52E+003	357.42	2.48E+005
m	27	357-	407	400.95	145.28	1.26	3.76E+004	415.70	2.43E+005
	28	432-	445	439.11	159.23	1.18	4.79E+005	1089.59	2.58E+005
	29	481-	494	488.03	177.12	1.28	4.30E+003	807.15	2.35E+005
M	30	524-	551	529.51	192.28	1.30	1.43E+004	367.14	1.70E+005
m	31	524-	551	544.71	197.84	1.30	8.83E+003	333.26	1.94E+005
	32	566-	579	573.25	208.28	1.27	2.21E+004	751.13	1.97E+005
M	33	587-	615	594.45	216.03	1.25	3.20E+004	356.04	1.61E+005
m	34	587-	615	609.28	221.45	1.26	3.35E+004	355.55	1.51E+005
	35	620-	634	627.62	228.15	1.40	9.46E+003	720.78	1.77E+005
M	36	654-	692	658.92	239.60	1.09	3.00E+003	262.58	1.08E+005
m	37	654-	692	665.02	241.83	1.09	1.36E+003	239.50	1.06E+005
m	38	654-	692	672.59	244.60	1.10	1.81E+003	239.93	1.14E+005
m	39	654-	692	685.67	249.38	1.10	3.24E+003	258.32	9.99E+004
	40	722-	733	726.71	264.39	1.05	1.23E+003	533.12	1.13E+005
M	41	744-	783	751.44	273.43	1.18	8.88E+003	260.70	9.80E+004
m	42	744-	783	762.69	277.54	1.19	6.65E+003	244.56	9.67E+004

Peak No.	ROI start	ROI end	Peak centroid	Energy (keV)	FWHM (keV)	Net Peak Area	Net Area Uncert.	Continuum Counts
m 43	744-	783	776.28	282.51	1.19	9.09E+003	260.51	9.51E+004
M 44	801-	829	805.79	293.30	1.23	1.32E+003	225.35	8.31E+004
m 45	801-	829	812.83	295.87	1.23	1.58E+003	221.52	9.10E+004
m 46	801-	829	820.21	298.57	1.23	4.82E+003	243.00	9.87E+004
m 47	801-	829	824.47	300.13	1.23	5.92E+003	256.27	9.01E+004
M 48	841-	886	846.29	308.11	1.31	2.52E+003	232.59	8.90E+004
m 49	841-	886	856.62	311.88	1.31	3.55E+004	307.83	1.04E+005
m 50	841-	886	868.75	316.32	1.32	5.12E+003	230.54	1.02E+005
m 51	841-	886	878.95	320.05	1.32	3.49E+004	307.10	9.29E+004
52	896-	909	902.69	328.73	1.30	5.81E+004	590.87	1.06E+005
M 53	932-	956	934.70	340.43	1.47	3.04E+003	226.40	6.61E+004
m 54	932-	956	944.45	343.99	1.47	1.09E+004	267.05	1.02E+005
m 55	932-	956	949.79	345.95	1.47	5.90E+003	244.31	1.02E+005
56	995-	1007	1000.05	364.32	1.06	1.15E+003	495.03	9.26E+004
57	1016-	1031	1024.36	373.21	1.39	1.61E+004	593.40	1.12E+005
M 58	1080-	1115	1087.46	396.29	1.34	1.70E+004	261.89	7.22E+004
m 59	1080-	1115	1100.55	401.07	1.34	1.38E+003	194.95	7.69E+004
m 60	1080-	1115	1108.76	404.07	1.35	1.16E+003	197.41	7.62E+004
M 61	1123-	1145	1129.85	411.78	1.44	2.94E+003	226.32	7.51E+004
m 62	1123-	1145	1140.54	415.69	1.44	1.37E+003	206.43	7.50E+004
63	1178-	1194	1186.45	432.48	1.33	7.38E+003	545.15	9.26E+004
64	1279-	1289	1283.79	468.07	1.52	1.26E+003	356.85	5.28E+004
M 65	1314-	1343	1322.30	482.15	1.45	2.41E+004	244.46	6.78E+004
m 66	1314-	1343	1335.58	487.00	1.46	9.97E+004	375.85	6.91E+004
67	1355-	1368	1360.99	496.29	1.38	3.55E+004	464.21	6.51E+004
M 68	1393-	1417	1400.97	510.91	2.16	1.10E+004	226.83	7.81E+004
m 69	1393-	1417	1409.29	513.95	1.43	4.28E+004	287.27	6.34E+004
70	1451-	1463	1455.84	530.98	1.30	1.42E+003	391.34	5.76E+004
M 71	1511-	1568	1519.66	554.31	1.45	4.81E+005	713.95	6.42E+004
m 72	1511-	1568	1532.65	559.06	1.45	4.09E+004	271.44	6.31E+004
m 73	1511-	1568	1546.21	564.02	1.46	5.99E+004	306.61	6.27E+004
m 74	1511-	1568	1560.63	569.29	1.46	3.07E+003	188.43	6.24E+004
M 75	1646-	1665	1652.00	602.69	1.93	1.14E+004	271.88	5.31E+004
m 76	1646-	1665	1657.86	604.84	1.93	2.77E+004	295.72	7.20E+004
77	1688-	1705	1696.72	619.05	1.52	2.66E+005	695.03	6.66E+004
78	1765-	1778	1769.94	645.82	0.75	7.05E+002	351.79	4.46E+004
M 79	1792-	1836	1800.80	657.10	1.56	5.10E+003	183.53	4.64E+004
m 80	1792-	1836	1822.05	664.87	1.57	5.17E+002	149.81	4.61E+004
m 81	1792-	1836	1830.12	667.82	1.57	7.13E+002	153.83	4.60E+004
M 82	1874-	1922	1878.92	685.66	1.53	5.46E+002	151.43	3.63E+004
m 83	1874-	1922	1898.02	692.65	1.53	1.56E+003	149.80	4.44E+004
m 84	1874-	1922	1913.49	698.30	1.53	1.51E+005	414.03	3.94E+004
85	1975-	1988	1982.77	723.64	2.21	2.22E+003	314.12	3.50E+004
86	2022-	2030	2026.28	739.54	1.75	8.64E+002	217.53	2.17E+004
M 87	2052-	2078	2059.29	751.61	1.61	7.23E+003	170.79	3.34E+004
m 88	2052-	2078	2072.94	756.60	1.61	1.41E+003	140.66	3.38E+004
89	2118-	2136	2127.13	776.41	1.60	4.35E+005	772.12	4.77E+004
M 90	2171-	2243	2180.05	795.77	1.66	1.71E+004	189.79	3.63E+004
m 91	2171-	2243	2196.55	801.80	1.66	1.97E+003	137.28	3.64E+004
m 92	2171-	2243	2212.86	807.76	1.67	9.71E+003	164.94	3.65E+004

Peak No.	ROI start	ROI end	Peak centroid	Energy (keV)	FWHM (keV)	Net Peak Area	Net Area Uncert.	Continuum Counts
m 93	2171-	2243	2234.54	815.69	1.67	3.75E+004	240.30	3.67E+004
M 94	2258-	2295	2267.48	827.73	1.62	1.21E+005	371.96	3.82E+004
m 95	2258-	2295	2286.52	834.69	1.63	8.10E+003	162.88	3.74E+004
96	2370-	2385	2376.85	867.72	1.67	8.22E+003	345.10	3.68E+004
97	2399-	2412	2408.45	879.27	1.79	2.36E+003	301.44	3.21E+004
98	2426-	2444	2435.50	889.16	1.70	2.23E+005	610.23	4.42E+004
M 99	2508-	2543	2518.29	919.43	1.69	3.64E+003	137.02	3.04E+004
m100	2508-	2543	2533.72	925.08	1.69	9.24E+003	162.27	2.96E+004
101	2596-	2615	2606.37	951.64	2.10	3.08E+003	349.99	3.41E+004
M102	2630-	2652	2638.92	963.54	2.22	2.66E+003	159.32	3.24E+004
m103	2630-	2652	2645.37	965.90	2.22	1.98E+003	158.77	3.57E+004
104	2709-	2716	2712.32	990.38	0.57	4.02E+001	159.80	1.27E+004
105	2749-	2768	2759.11	1007.49	1.79	5.82E+003	334.59	3.03E+004
106	2848-	2868	2858.60	1043.86	1.76	1.15E+005	486.52	3.37E+004
M107	2941-	2982	2948.26	1076.64	1.76	2.29E+004	193.81	2.41E+004
m108	2941-	2982	2960.67	1081.18	1.76	2.53E+003	121.45	2.66E+004
m109	2941-	2982	2972.43	1085.48	1.77	1.91E+003	119.59	2.61E+004
110	2999-	3019	3009.70	1099.11	1.80	7.63E+004	431.51	3.03E+004
M111	3044-	3077	3054.29	1115.41	1.80	4.47E+004	236.78	2.49E+004
m112	3044-	3077	3067.97	1120.41	1.80	1.88E+005	435.13	2.48E+004
M113	3204-	3235	3212.11	1173.11	1.84	2.56E+004	183.77	1.57E+004
m114	3204-	3235	3225.15	1177.88	1.84	1.15E+003	94.48	1.69E+004
115	3248-	3263	3255.55	1189.00	1.15	6.39E+002	210.77	1.46E+004
M116	3315-	3350	3320.47	1212.73	1.79	7.60E+002	86.95	1.07E+004
m117	3315-	3350	3329.52	1216.04	1.80	1.77E+003	94.75	1.39E+004
m118	3315-	3350	3343.85	1221.28	1.80	1.11E+003	90.35	1.38E+004
M119	3422-	3497	3428.96	1252.40	1.81	3.06E+003	88.93	1.12E+004
m120	3422-	3497	3440.30	1256.55	1.81	3.48E+002	64.55	1.24E+004
m121	3422-	3497	3464.10	1265.25	1.81	1.44E+002	61.55	1.26E+004
m122	3422-	3497	3482.61	1272.02	1.82	3.31E+002	63.69	1.21E+004
m123	3422-	3497	3489.20	1274.42	1.82	4.23E+002	64.61	1.13E+004
M124	3525-	3560	3535.70	1291.43	1.90	5.10E+004	231.66	1.23E+004
m125	3525-	3560	3550.47	1296.83	1.90	7.51E+004	274.84	1.18E+004
126	3595-	3616	3606.44	1317.29	1.96	9.80E+004	387.71	1.39E+004
127	3636-	3657	3647.28	1332.23	2.37	2.43E+004	266.95	1.25E+004
128	3735-	3757	3746.35	1368.45	1.97	1.30E+005	421.91	1.24E+004
129	3780-	3800	3789.58	1384.25	0.75	1.54E+000	178.32	8.75E+003
M130	3808-	3863	3819.50	1395.19	1.94	2.51E+003	78.21	7.36E+003
m131	3808-	3863	3834.03	1400.50	1.95	3.93E+002	59.27	7.50E+003
m132	3808-	3863	3853.82	1407.74	1.95	2.14E+003	74.33	6.86E+003
133	3991-	4009	3998.70	1460.71	1.78	1.15E+003	138.04	5.29E+003
134	4025-	4047	4036.82	1474.65	2.00	5.54E+004	280.31	5.98E+003
135	4162-	4184	4173.10	1524.48	2.05	2.66E+004	212.85	4.83E+003
M136	4357-	4401	4368.63	1595.97	2.06	8.19E+004	276.24	4.08E+003
m137	4357-	4401	4390.39	1603.93	2.06	2.32E+003	62.56	3.52E+003
138	4509-	4527	4516.40	1650.00	1.88	2.24E+003	113.47	3.11E+003
139	4549-	4558	4553.72	1663.64	1.27	3.56E+001	61.99	1.68E+003
140	4617-	4639	4627.68	1690.69	2.05	2.33E+003	128.67	3.67E+003
141	4728-	4751	4739.88	1731.71	2.31	8.50E+003	149.90	3.49E+003
142	4821-	4840	4828.74	1764.20	0.85	3.63E+002	106.14	3.11E+003

Peak No.	ROI start	ROI end	Peak centroid	Energy (keV)	FWHM (keV)	Net Peak Area	Net Area Uncert.	Continuum Counts
M143	4864-	4897	4869.97	1779.27	1.75	2.42E+002	42.80	2.29E+003
m144	4864-	4897	4891.13	1787.01	1.75	1.37E+002	38.88	2.53E+003
145	4972-	4993	4981.37	1820.01	2.20	1.88E+003	119.22	3.27E+003
146	5109-	5132	5121.65	1871.29	2.22	4.02E+003	132.12	3.36E+003
147	5256-	5274	5267.08	1924.47	0.96	4.52E+002	91.33	2.34E+003
M148	5349-	5368	5353.98	1956.24	1.04	1.12E+002	29.48	1.18E+003
m149	5349-	5368	5363.77	1959.82	1.04	1.00E+002	27.98	1.11E+003
150	5487-	5511	5499.00	2009.27	2.23	3.42E+003	126.31	3.04E+003
151	5539-	5561	5552.11	2028.68	2.52	1.28E+003	110.78	2.83E+003
M152	5687-	5741	5699.79	2082.68	2.65	1.12E+003	47.77	2.82E+003
m153	5687-	5741	5728.93	2093.33	2.66	3.00E+003	62.78	3.27E+003
154	6124-	6149	6136.79	2242.46	3.44	1.14E+004	160.61	3.39E+003
155	6413-	6436	6423.50	2347.29	2.05	8.34E+002	117.72	3.25E+003
156	6587-	6605	6597.63	2410.95	1.43	3.91E+002	101.71	2.94E+003
157	6887-	6911	6897.92	2520.75	2.31	2.28E+003	139.05	4.13E+003
158	7107-	7118	7112.05	2599.04	0.37	4.61E+001	52.09	1.06E+003
159	7142-	7166	7152.99	2614.01	2.72	6.54E+002	91.13	1.85E+003
160	7520-	7547	7534.06	2753.34	2.66	7.00E+004	269.77	6.22E+002

M = First peak in a multiplet region

m = Other peak in a multiplet region

F = Fitted singlet

Errors quoted at 1.000 sigma

 ***** N U C L I D E I D E N T I F I C A T I O N R E P O R T *****

Sample Title: JW_15APR08_SH
 Nuclide Library Used: C:\GENIE2K\CAMFILES\STDLIB.NLB

..... IDENTIFIED NUCLIDES

Nuclide Name	Id Confidence	Energy (keV)	Yield (%)	Activity (uCi/g)	Activity Uncertainty
NA-22	0.998	1274.54*	99.94	9.58658E-005	1.47595E-005
NA-24	0.439	1368.53*	100.00	2.41742E+002	8.82878E+000
		2754.03*	99.94	3.16883E+002	1.61660E+002
K-40	0.999	1460.81*	10.67	2.79424E-003	3.56784E-004
K-42	0.313	1524.67*	17.90	2.08347E+003	1.18926E+002
SC-46	0.998	889.28*	99.98	3.84357E-002	1.10503E-003
		1120.55*	99.99	4.01030E-002	8.83004E-004
SC-47	0.969	159.38*	67.90	1.43104E-001	4.75864E-003
CR-51	0.999	320.08*	9.83	2.77585E-002	1.32410E-003
MN-54	0.997	834.83*	99.97	1.25483E-003	4.34590E-005
FE-59	0.998	142.65*	1.03	2.20062E-002	1.51885E-003
		192.34*	3.11	2.21952E-002	8.73288E-004
		1099.22*	56.50	2.99537E-002	8.84425E-004
		1291.56*	43.20	3.05394E-002	9.45895E-004
CO-60	0.994	1173.22*	100.00	5.34456E-003	1.10930E-004
		1332.49*	100.00	5.74338E-003	1.49500E-004
ZN-65	0.998	1115.52*	50.75	1.78680E-002	4.08350E-004
SE-75	0.699	96.73	3.41		
		121.11*	16.70	4.79983E-003	2.25455E-004
		136.00*	59.20	4.87142E-003	2.38137E-004
		198.60*	1.45	2.76682E-002	1.35046E-003
		264.65*	59.80	1.16730E-004	5.08891E-005
		279.53	25.20		
		303.91	1.32		
		400.65*	11.40	9.92699E-004	1.50329E-004
AS-76	0.752	559.10*	44.70	1.59645E+000	4.61997E-002
		563.23*	1.17	9.01405E+001	2.55531E+000
		657.03*	6.10	1.68881E+000	7.42812E-002
		1212.72*	1.63	1.64871E+000	1.90938E-001
		1216.02*	3.84	1.63410E+000	9.23955E-002
		1228.52	1.39		
BR-82	0.861	221.45*	2.26	3.13927E+000	1.16571E-001
		554.32*	70.60	3.22301E+000	9.18278E-002
		606.30	1.17		
		619.07*	43.10	3.23300E+000	8.36161E-002
		698.33*	28.20	3.11703E+000	8.01974E-002
		776.49*	83.31	3.34979E+000	9.10913E-002
		827.81*	24.20	3.40131E+000	9.61537E-002
		1007.57*	1.27	3.72004E+000	2.35856E-001
		1043.97*	27.30	3.51680E+000	9.07566E-002
		1317.47*	26.90	3.81448E+000	8.56924E-002
		1474.82*	16.58	3.92098E+000	1.81958E-001

Interference Corrected Activity Report 5/8/2008 11:17:05 AM Page 7

Nuclide Name	Id Confidence	Energy (keV)	Yield (%)	Activity (uCi/g)	Activity Uncertainty
KR-85	1.000	513.99*	0.43	9.78615E-001	3.13669E-002
SR-85	1.000	513.99*	99.27	4.61510E-003	1.47929E-004
ZR-95	0.978	724.18*	43.70	7.40860E-004	1.07559E-004
		756.72*	55.30	3.88624E-004	4.07610E-005
Ru-97	0.808	215.70*	100.00	1.02056E-002	3.70512E-004
		324.40	12.00		
MO-99	0.825	140.51*	88.70	4.33970E-003	1.55548E-004
		181.06	6.20		
		366.43	1.37		
		739.58*	12.80	7.05176E-003	1.83859E-003
		778.00	4.50		
RU-103	0.824	497.08*	89.00	4.38052E-003	2.90690E-004
		610.33	5.60		
Sn-117m	0.929	158.56*	86.00	3.19729E-002	7.97785E-004
SB-122	0.958	563.93*	70.60	7.21940E-002	2.15515E-003
		692.80*	3.70	4.30123E-002	4.29814E-003
Te-123m	0.992	159.00*	84.00	2.27222E-002	5.63776E-004
SB-124	0.895	602.71*	97.87	1.45627E-003	5.14906E-005
		645.85*	7.26	1.28683E-003	6.43368E-004
		709.31	1.42		
		713.82	2.38		
		722.78*	11.10	2.93296E-003	4.23238E-004
		968.20	1.92		
		1045.16	1.86		
		1325.50	1.50		
		1355.24	1.00		
		1368.21*	2.51	1.37164E+000	3.87356E-002
		1436.60	1.14		
		1691.02*	49.00	1.57708E-003	1.77992E-004
I-131	0.732	80.18	2.62		
		284.30	6.05		
		364.48*	81.20	2.03274E-004	8.83627E-005
		636.97	7.26		
		722.89*	1.80	3.30755E-002	4.79541E-003
TE-132	0.934	111.76	1.85		
		116.30*	1.94	7.70300E-002	4.49638E-003
		228.16*	88.00	2.88788E-003	2.98332E-004
CS-134	0.950	475.35	1.46		
		563.23*	8.38	7.69897E-002	2.23033E-003
		569.32*	15.43	2.15747E-003	1.46133E-004
		604.70*	97.60	3.25410E-003	9.23287E-005
		795.84*	85.40	2.93834E-003	8.83178E-005
		801.93*	8.73	3.34017E-003	2.50476E-004
		1038.57	1.00		
		1167.94	1.80		
		1365.15	3.04		
LA-140	0.978	328.77*	20.50	2.87642E-002	1.38242E-003
		432.53*	2.94	3.26444E-002	2.75603E-003
		487.03*	45.50	3.17609E-002	1.18052E-003
		751.79*	4.40	3.52564E-002	1.44644E-003
		815.85*	23.50	3.68314E-002	1.31394E-003

Nuclide Name	Id Confidence	Energy (keV)	Yield (%)	Activity (uCi/g)	Activity Uncertainty
LA-140	0.978	867.82*	5.63	3.56459E-002	1.87864E-003
		919.63*	2.88	3.24829E-002	1.84009E-003
		925.24*	7.09	3.37016E-002	1.24292E-003
		1596.49*	95.49	3.77173E-002	2.75925E-003
CE-141	0.995	145.44*	48.40	3.36830E-003	9.30502E-005
CE-144	0.751	80.11	1.60		
		133.54*	10.80	1.16043E-002	8.13433E-004
Nd-147	0.967	91.10*	100.00	1.40077E-003	4.75109E-005
		531.00*	46.90	5.11610E-004	1.41443E-004
EU-152	0.740	121.78*	28.40	2.69642E-003	1.05229E-004
		244.69*	7.49	1.22838E-003	1.72156E-004
		344.27*	26.50	2.81400E-003	1.48671E-004
		411.11*	2.21	1.07070E-002	9.49126E-004
		443.98	3.11		
		778.89	12.74		
		867.32*	4.16	3.11659E-002	1.89785E-003
		964.01*	14.40	3.19665E-003	2.21799E-004
		1085.78*	10.00	3.70349E-003	2.71164E-004
		1112.02	13.30		
		1407.95*	20.70	2.57911E-003	1.39858E-004
		Lu-177	0.976	112.95*	6.40
208.36*	11.00			2.07984E-002	9.85058E-004
249.67*	0.21			1.83409E-001	1.63537E-002
321.30	0.22				
Ta-182	0.735	222.11*	7.49	2.21144E-002	8.21174E-004
		1001.69	2.07		
		1121.30*	34.90	1.12857E-001	2.48492E-003
		1189.05*	16.23	8.71122E-004	2.87730E-004
		1221.41*	26.98	9.35879E-004	7.78901E-005
		1231.00	11.44		
		1289.10	1.35		
		205.80	3.30		
IR-192	0.867	296.00*	29.00	3.50170E-004	5.15393E-005
		308.50*	30.00	5.59132E-004	5.73841E-005
		316.50*	83.00	4.20807E-004	2.66895E-005
		468.10*	48.00	2.56291E-004	7.28865E-005
		484.60	3.20		
		588.60	3.20		
		588.60	4.60		
		604.90*	8.20	4.14692E-002	1.16969E-003
		612.50	5.30		
		293.50*	2.60	3.28867E+000	5.78249E-001
IR-194	0.615	328.50*	13.00	3.19172E+001	1.46110E+000
		411.80*	95.00	1.98589E-003	2.17977E-004
Au-198	0.959	411.80*	95.00	1.98589E-003	2.17977E-004
PB-212	0.507	74.81*	9.60	6.41061E-003	4.84472E-004
		77.11	17.50		
		87.20*	6.30	5.64205E-003	3.20905E-004
		89.80	1.75		
		115.19	0.60		
		238.63*	44.60	3.36974E-004	3.22074E-005
		300.09*	3.41	1.04894E-002	6.49762E-004

Interference Corrected Activity Report 5/8/2008 11:17:05 AM Page 9

Nuclide Name	Id Confidence	Energy (keV)	Yield (%)	Activity (uCi/g)	Activity Uncertainty
PA-234	0.470	94.67*	15.50	4.63589E-003	1.55842E-004
		98.44*	25.10	5.28626E-003	1.40257E-004
		111.00*	8.55	4.62882E-003	1.92642E-004
		131.28*	20.00	8.05511E-004	6.94282E-005
		152.70	7.20		
		226.87	6.50		
		569.26*	10.40	3.17797E-003	2.14059E-004
		733.00	8.50		
		883.24	12.00		
		946.00	20.00		
		949.00	7.80		
		AM-241	0.913	59.54*	36.30

* = Energy line found in the spectrum.

@ = Energy line not used for Weighted Mean Activity

Energy Tolerance : 1.000 keV

Nuclide confidence index threshold = 0.30

Errors quoted at 1.000 sigma

 ***** I N T E R F E R E N C E C O R R E C T E D R E P O R T *****

	Nuclide Name	Nuclide Id Confidence	Wt mean Activity (uCi/g)	Wt mean Activity Uncertainty
	NA-22	0.998	9.586578E-005	1.475945E-005
	NA-24	0.439	2.416189E+002	8.822259E+000
	K-40	0.999	2.794242E-003	3.567839E-004
	K-42	0.313	2.083470E+003	1.189263E+002
	SC-46	0.998	3.925557E-002	6.900115E-004
?	SC-47	0.969	1.431039E-001	4.758645E-003
	CR-51	0.999	2.775850E-002	1.324102E-003
	MN-54	0.997	1.254828E-003	4.345905E-005
	FE-59	0.998	2.682305E-002	4.914550E-004
	CO-60	0.994	5.486173E-003	8.908480E-005
	ZN-65	0.998	1.786796E-002	4.083501E-004
	SE-75	0.699	8.530276E-004	4.346712E-005
	AS-76	0.752	1.626010E+000	3.548098E-002
	BR-82	0.861	3.369390E+000	3.124201E-002
?	KR-85	1.000	9.786153E-001	3.136694E-002
?	SR-85	1.000	4.615104E-003	1.479287E-004
	ZR-95	0.978	3.859091E-004	3.750389E-005
	Ru-97	0.808	1.020557E-002	3.705116E-004
	MO-99	0.825	4.358968E-003	1.549940E-004
	RU-103	0.824	4.380523E-003	2.906903E-004
?	Sn-117m	0.929	3.197289E-002	7.977855E-004
	SB-122	0.958	6.362668E-002	1.907266E-003
?	Te-123m	0.992	2.272216E-002	5.637764E-004
	SB-124	0.895	1.463602E-003	4.899092E-005
	I-131	0.732	2.029781E-004	8.830661E-005
	TE-132	0.934	3.233359E-003	2.986851E-004
	CS-134	0.950	2.735623E-003	5.675222E-005
	LA-140	0.978	3.323223E-002	4.621744E-004
	CE-141	0.995	3.368297E-003	9.305021E-005
	CE-144	0.751	1.160430E-002	8.134325E-004
	Nd-147	0.967	1.310619E-003	4.503802E-005
	EU-152	0.740	2.408525E-003	5.556066E-005
X	Eu-154	0.447		
	Lu-177	0.976	2.642796E-002	6.526908E-004
	Ta-182	0.735	9.115759E-004	7.487998E-005
	IR-192	0.867	4.159536E-004	2.097645E-005
	IR-194	0.615	2.171945E+000	5.421385E-001
	Au-198	0.959	1.539166E-003	2.012623E-004
	PB-212	0.507	4.404445E-004	3.193784E-005
	PA-234	0.470	2.104480E-003	5.384299E-005
	AM-241	0.913	2.085183E-003	3.780469E-004

? = nuclide is part of an undetermined solution

X = nuclide rejected by the interference analysis

@ = nuclide contains energy lines not used in Weighted Mean Activity

Errors quoted at 1.000 sigma

Interference Corrected Activity Report 5/8/2008 11:17:05 AM Page 11

***** U N I D E N T I F I E D P E A K S *****

Peak Locate Performed on: 5/8/2008 11:17:03 AM
 Peak Locate From Channel: 1
 Peak Locate To Channel: 8192

Peak No.	Energy (keV)	Peak Size in Counts per Second	Peak CPS % Uncertainty	Peak Type	Tol. Nuclide
M 1	57.16	2.8629E-001	3.73		
m 3	60.84	2.2286E-001	4.62		
m 4	62.57	4.1107E-001	2.58	D-Esc.	
m 5	64.94	1.1303E-001	8.79		
m 6	66.99	3.3667E-001	3.06		
m 7	69.19	8.4397E-001	1.37		
m 8	72.33	2.1318E-001	4.90		
M 10	84.38	1.9251E-001	5.18		
m 15	102.94	7.4155E+000	0.23		
m 16	105.79	5.6124E-001	1.74		
m 21	123.55	1.3949E+000	0.78		
29	177.12	9.9467E-002	18.78	Tol.	SB-125
m 37	241.83	3.1395E-002	17.66	Tol.	PB-214
M 41	273.43	2.0565E-001	2.93	Sum	
m 42	277.54	1.5391E-001	3.68	Sum	
m 43	282.51	2.1032E-001	2.87	Sum	
m 46	298.57	1.1167E-001	5.04	Sum	
m 49	311.88	8.2280E-001	0.87	Sum	
M 53	340.43	7.0463E-002	7.44	Sum	
m 55	345.95	1.3664E-001	4.14	D-Esc.	
57	373.21	3.7227E-001	3.69	Sum	
M 58	396.29	3.9418E-001	1.54	Sum	
m 60	404.07	2.6892E-002	16.99	Sum	
m 62	415.69	3.1801E-002	15.03	Sum	
M 65	482.15	5.5727E-001	1.02		
M 68	510.91	2.5481E-001	2.06	Sum	
m 80	664.87	1.1972E-002	28.97	Sum	
m 81	667.82	1.6495E-002	21.59	D-Esc.	
M 82	685.66	1.2631E-002	27.75	Sum	
m 92	807.76	2.2482E-001	1.70	Sum	
97	879.27	5.4537E-002	12.79	Sum	
101	951.64	7.1330E-002	11.36	Sum	
m103	965.90	4.5779E-002	8.03	Sum	
104	990.38	9.3135E-004	397.17	Sum	
M107	1076.64	5.3107E-001	0.84	Sum	
m108	1081.18	5.8536E-002	4.80	Sum	
m114	1177.88	2.6704E-002	8.19	Sum	
M119	1252.40	7.0845E-002	2.91	Sum	
m120	1256.55	8.0625E-003	18.53	Sum	
m121	1265.25	3.3229E-003	42.88	Sum	
m122	1272.02	7.6582E-003	19.25	Sum	
m125	1296.83	1.7394E+000	0.37	Sum	
129	1384.25	3.5559E-005	11608.0	Sum	
M130	1395.19	5.8070E-002	3.12	Sum	
m131	1400.50	9.0898E-003	15.09	Sum	
m137	1603.93	5.3588E-002	2.70	Sum	

Interference Corrected Activity Report 5/8/2008 11:17:05 AM Page 12

Peak No.	Energy (keV)	Peak Size in Counts per Second	Peak CPS % Uncertainty	Peak Type	Tol. Nuclide
138	1650.00	5.1853E-002	5.07	Sum	
139	1663.64	8.2396E-004	174.15	Sum	
141	1731.71	1.9668E-001	1.76	D-Esc.	
142	1764.20	8.3936E-003	29.27	Sum	
M143	1779.27	5.6111E-003	17.65	Sum	
m144	1787.01	3.1789E-003	28.31	Sum	
145	1820.01	4.3541E-002	6.34	Sum	
146	1871.29	9.2998E-002	3.29	Sum	
147	1924.47	1.0455E-002	20.22	Sum	
M148	1956.24	2.6034E-003	26.21	Sum	
m149	1959.82	2.3196E-003	27.93	Sum	
150	2009.27	7.9190E-002	3.69	Sum	
151	2028.68	2.9677E-002	8.64	Sum	
M152	2082.68	2.5976E-002	4.26	Sum	
m153	2093.33	6.9401E-002	2.09	Sum	
154	2242.46	2.6287E-001	1.41	S-Esc.	
155	2347.29	1.9307E-002	14.11	Sum	
156	2410.95	9.0602E-003	25.99	Sum	
157	2520.75	5.2832E-002	6.09	Sum	
158	2599.04	1.0667E-003	113.03		
159	2614.01	1.5141E-002	13.93		

M = First peak in a multiplet region

m = Other peak in a multiplet region

F = Fitted singlet

Errors quoted at 1.000 sigma

APPENDIX C

NIST-CERTIFIED "ORCHARD LEAVES" CERTIFICATE INFORMATION

Table 1. Certified Values of Constituent Elements^a

<u>Major Constituents</u>		<u>Minor Constituents</u>	
<u>Element</u>	<u>Content</u> <u>Wt. Percent</u>	<u>Element</u>	<u>Content</u> <u>Wt. Percent</u>
Nitrogen	2.76 ± 0.05	Magnesium	0.62 ± 0.02
Calcium	2.09 ± 0.03	Phosphorus	0.21 ± 0.01
Potassium	1.47 ± 0.03		

The uncertainties shown above include both the imprecision, expressed as the standard deviation of a single measurement, and an allowance for unknown sources of systematic error.

Trace Constituents^a

<u>Element</u>	<u>Content</u> <u>µg/g</u>	<u>Element</u>	<u>Content</u> <u>µg/g</u>
Iron	300 ± 20	Antimony	2.9 ± 0.3
Manganese	91 ± 4	Chromium	2.6 ± 0.3
Sodium "	82 ± 6	Nickel	1.3 ± 0.2
Lead	45 ± 3	Molybdenum	0.3 ± 0.1
Strontium	37 ± 1	Mercury	0.155 ± 0.015
Boron	33 ± 3	Cadmium	0.11 ± 0.01
Zinc	25 ± 3	Selenium	0.08 ± 0.01
Copper	12 ± 1	Thorium	0.064 ± 0.006
Rubidium	12 ± 1	Uranium	0.029 ± 0.005
Arsenic	10 ± 2	Beryllium	0.027 ± 0.010

The uncertainties shown above are the imprecisions expressed as either two standard deviations of a single determination (commonly, but perhaps incorrectly, called the "95 percent confidence limit"), or the entire range of observed results - whichever of the two is larger. No additional allowance for the uncertainty from unknown sources of systematic error has been included, since these are considered to be small relative to the imprecision as expressed.

APPENDIX D

NIST-CERTIFIED “SPINACH LEAVES” CERTIFICATE INFORMATION

Table 2. Reference Concentration Values of Constituent Elements^{a,b,c}

Element	Mass Fraction (%)
Nitrogen (Total) ^d	6.06 ± 0.20
Nitrogen (Organic) ^d	6.20 ± 0.25
Nitrogen (Protein) ^d	5.68 ± 0.13

Element	Mass Fraction (mg/kg)	Element	Mass Fraction (mg/kg)
Europium	0.0055 ± 0.0010	Rubidium	12.7 ± 1.6
Scandium	0.0055 ± 0.0006	Uranium	0.155 ± 0.023

- ^a NIST has replaced the previously used term “non-certified” with “reference value” or “information value,” as appropriate.
- ^b Each reference concentration value, expressed as a mass fraction on a dry-mass basis, is an equally weighted mean of results provided by NIST and/or collaborating laboratories. The uncertainty in the reference concentration values is calculated as $U = ku_c$. The quantity u_c is the combined standard uncertainty calculated according to the ISO Guide [1], which accounts for the combined effect of the within-laboratory variance for all participating laboratories at one standard deviation and bias between methods. The coverage factor, k , is determined from the Student’s t -distribution corresponding to the appropriate associated degrees of freedom and 95 % confidence for each analyte.
- ^c These reference values are reported on a dry-mass basis. In order for these reference values to be valid, the material must be dried according to the instructions provided above.
- ^d Data from three methods for the determination of nitrogen have been treated separately. Total nitrogen was determined by prompt gamma activation analysis; “organic” nitrogen was determined by the Dumas method; and “protein” nitrogen was determined by the Kjeldahl method.

APPENDIX E

MASS VALUES USED IN CALCULATIONS

Sample	Label	Mass (g)
Cinnamon	K ₁	0.2119
Cinnamon	K ₃	0.2051
Cinnamon	K ₆	0.2003
Cumin	C ₁	0.195
Cumin	C ₂	0.2235
Cumin	C ₄	0.2199
Cumin	C ₆	0.2118
Cumin	C ₇	0.1956
Turmeric	T ₁	0.2264
Turmeric	T ₃	0.2049
Turmeric	T ₄	0.2169
Turmeric	T ₅	0.2026
Oregano	O ₁	0.2127
Paprika	P ₄	0.217
Chili Powder	N ₂	0.1949
Thyme	B ₅	0.2171
Cayenne	E ₁	0.2026
Ginger	G ₁	0.2021
Orchard Leaves	X ₃	0.1056
Orchard Leaves	X ₄	0.1031
Orchard Leaves	X ₅	0.1026
Orchard Leaves	X ₆	0.104
Orchard Leaves	X ₇	0.114
Orchard Leaves	X ₉	0.1076
Spinach Leaves	R ₃	0.1087

APPENDIX F**ADDITIONAL LARGER MASS VALUES**

Sample	Mass (g)
Spinach leaves	2.2294
Ginger	3.8049
Paprika	3.8066
Cinnamon	4.4623

VITA

Name: Jatara Rob Wise

Address: Department of Nuclear Engineering
3133 TAMU
College Station, TX 77843-3133

Email Address: jatara@tamu.edu

Education: B.S., Physics, Lamar University at Beaumont, 2003
M.S., Health Physics, Texas A&M University, 2008