

**CONSIDERATIONS FOR ENERGY EFFICIENT  
SHOWERS IN HOT-HUMID CLIMATES**

By

D. E. Claridge and W.D. Turner  
Energy Systems Laboratory  
Department of Mechanical  
Engineering  
Texas A&M University

**ABSTRACT**

Measurements have been conducted on four low-flow showerheads currently recommended by utilities. These measurements were made to determine expected cost savings in two prison installations, based on water savings, sewer savings, and energy savings. Current shower flowrates of 2.5 gpm were reduced to 1.95 gpm without affecting shower quality. Three heads tested will provide total annual savings of \$12,337 at Prison 1 and \$11,036 at Prison 2, or over \$35 per showerhead compared with the showerheads currently being used by the prisons. The estimated payback is less than two months.

The savings determined are about one-third the estimate made before testing, since the low flow heads tested require that supply water temperatures be approximately 10 F higher than standard heads to achieve comparable temperatures in the spray pattern. This is because of evaporative cooling by the aerating shower nozzles. Further study also indicated lower shower water usage than initially estimated due to shorter inmate shower times. Over 80% of the savings projected will be due to reduced water and sewer costs. Further testing to determine whether very low flow heads exist which do not require elevated supply temperatures are recommended.

**INTRODUCTION**

A design review of two planned prison facilities [1] identified reduced flow showerheads as a

measure which had the potential for saving over \$70,000/year with an estimated initial investment of less than \$7,000. Until now, such measures depended on manufacturers estimates which often did not consider increased water supply temperature, spray patterns, etc. This project was intended to measure the flow rate of several low-flow showerheads which have been reported to provide acceptable shower quality and verify the energy savings of the showerheads. Subsequently, four models of water-conserving shower heads were obtained and tested.

The measurements showed that the showerheads operated at lower flow rates than standard showers but subjective impressions from use of the showerheads suggested that inlet water temperature had to be raised to obtain an equal level of comfort with the lower flow showerheads. Simple calculations showed that this phenomenon had the potential to reduce the expected energy savings substantially for typical operation in Texas.

This has significant implications for everyone who purchases or uses showerheads; this is particularly true in hot climates where supply water temperatures are relatively high.

**TESTS CONDUCTED**

**Showerheads Tested**

Two major Northeast utilities [2] have conducted extensive shower testing. The utilities have not released results of their testing, but provided the names of three

manufacturers which had supplied showerheads for their programs. The utilities reported they had been highly satisfied with customer response to showerheads from these manufacturers.

To avoid listing manufacturer's names, the shower nozzles will simply be referred to by number (1-5). The specific details are found in Reference 3.

Two heads of one model (#4, #5) were tested as a check on the repeatability of the measurements. All except number 3 are aerating type heads, which produce a very fine spray or mist in the spray pattern. Number 3 is an adjustable head with a simple plastic adjusting ring. It provides a useful basis for comparison since it is not an aerating head, but would not be suitable for prison use, since the adjusting ring is completely removable from the head. This head was tested at the limits of its course/fine spray adjustment, with the head labeled as #3C when on the course setting and #3F when on the fine setting.

#### Test Setup

A standard three-foot square shower stall was set up at the Energy Systems Laboratory with the showerhead position at a height of 72-inches. The cold and hot water

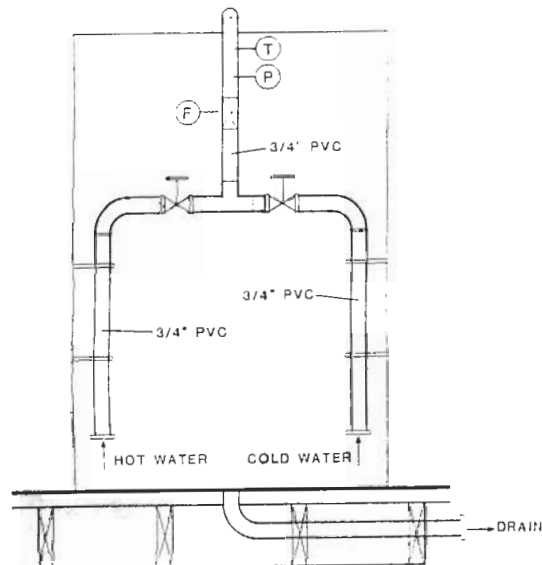

Figure 1. Schematic drawing of shower showing positions of valves, rotameter (F), pressure tap (P), and mixed water temperature thermocouple (T).

were mixed using two ball valves and the mixed water line was instrumented to measure the pressure, flow rate and temperature of the water entering the showerhead as shown in Figure 1.

Six temperature measurements were normally taken as shown in Figure 2. The dry-bulb and wet-bulb temperatures ( $T_{room}$ ,  $T_{wb}$ ) of the laboratory just outside the shower stall were also recorded. The entering water temperature,  $T_{water}$ , was taken in the water line near the showerhead. Three measurements were then made near the center of the shower spray pattern at distances of one foot ( $T_1$ ), two feet ( $T_2$ ), and three feet ( $T_3$ ) from the showerhead, respectively. All measurements except  $T_{wb}$  were made with Type T (copper constantan) thermocouples.  $T_{wb}$  was measured with a mechanically aspirated mercury thermometer enclosed in a standard wick.

Measurements were made at additional positions during some of the preliminary measurements, but were not used in the final analysis since they had minimal value in assessing differences between the different showerheads. These measurements included one outside the spray pattern, but inside the shower stall. This measurement was typically higher than ambient when the shower was running but

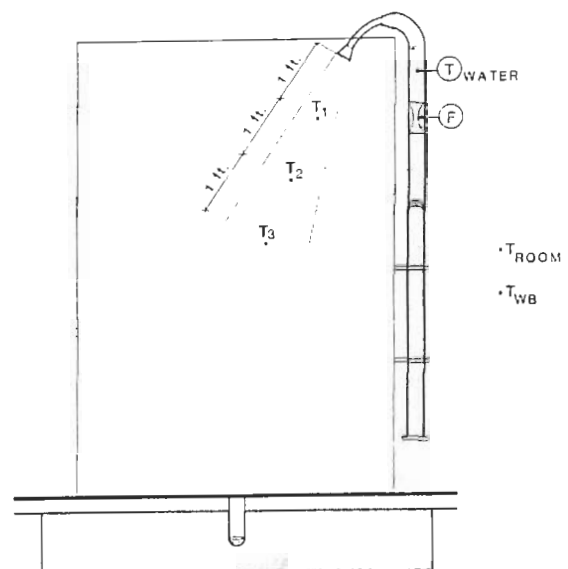

Figure 2. Schematic drawing showing positions of six key temperature measurement positions.

significantly cooler than those taken within the water pattern. Other measurements were taken one-, two-, and three-feet from the showerhead along a line near the edge of the shower spray pattern.

A limited number of tests were also conducted where people entered the shower stall and the temperature was adjusted until comfort was achieved. The non-aerating head provided shower comfort with inlet water temperatures 4-10 F lower than the other showerheads.

**TEST RESULTS**

**Flow-Rate Testing**

The flow rate of the showers was measured, typically near 40 psig. Results at 40 psig for the showerheads tested were as follows:

Head #	Flow @ 40 psig (gpm)	Rated Flow @ 40 psig (gpm)
1	1.95 (1.92-2.1)	1.81
2	1.97 (1.9-2.0)	2.00
3	2.10 (1.9-2.2)	2.75
4	1.90 (1.9-1.9)	1.81
5	1.95 (1.9-2.0)	1.81

The measured flow values shown are the average of multiple measurements with the range of measured values shown in parentheses. Since heads #4 and #5 were two samples of the same model and #1 had the same rated flow, we conclude that there were not significant differences in flow among the three aerating heads tested. Hence, a value of 1.95 gpm will be used for comparison with the rated flow of 2.5 gpm @ 40 psig for the models currently used in prison facilities.

Initial tests were conducted during the summer when interior temperatures at the ESL were typically in the 90-95 F range and "cold" water temperatures were comparable. Tests were conducted at several water temperatures, but the most informative were those made using "cold" water. Results of these tests are summarized in Table 1.

The water enters the showerhead at  $T_{water}$ , reaches the temperature  $T_{shower}$  near the head in the spray pattern and drops to  $T_{stall}$  in the shower stall, but outside the main spray pattern, while the temperature of the lab was  $T_{room}$ . The most striking result shown in the table is that the stall temperature is 5.1 F below the room temperature and 7.6 F lower than the temperature at which the water was supplied to the shower! This is a result of evaporative cooling by the aerating shower nozzles. The amount of evaporative cooling which occurs depends on the nozzle design, the water supply temperature, and the wet-bulb temperature.

Subsequently, 14-28 measurements were made on each showerhead using a variety of water temperatures and room temperatures. Temperatures were measured at five locations as noted in Figures 1 and 2. Results of these measurements are contained in Reference 3.

The non-aerating head #3C consistently produced higher temperatures (i.e., less evaporative cooling) within the spray pattern for a given supply temperature,  $T_{water}$ . Consequently, head #3C has been used as a base

Table 1

Results of Initial Showerhead Testing Using an Aerating Nozzle

Measurement #	$T_{room}$	$T_{water}$	$T_{shower}$	$T_{stall}$
1	90.4	92.8	91.3	84.8
2	90.3	92.7	91.2	84.6
3	89.7	92.5	91.2	85.4
4	89.7	92.7	91.3	84.9
5	89.8	92.8	91.2	85.6
6	90.2	92.8	91.4	85.8
7	90.6	92.9	91.2	85.2
8	91.0	92.9	90.9	85.1
9	90.9	92.8	90.7	85.0
Average	90.3	92.8	91.2	85.2

case for the comparison presented in Table 2. The water temperature which must be supplied to the other heads to approximate the temperatures in the spray pattern of #3C when supplied at 105 F is given in the Table. Note that 105 F is a typical supply temperature for prison units.

Due to variation in the results measured for different heads at different positions within the spray pattern and to changes in laboratory conditions, a procedure was developed to normalize and compare data taken at a variety of "hot" water temperatures and "room" temperatures. This procedure is described in Reference 3. Using these procedures, Table 2 shows the water temperature required by the aerating heads to produce the same temperatures at distances of one-, two- and three-feet from the head as those produced by head #3C when it is supplied with 105 F water. The average value of the temperatures required at these distances is shown in the column labeled "Avg." and the increase in temperature required compared to #3C is shown in the column labeled "Diff."

These results show that the aerating heads require water 2.8 to 10.9 F warmer on average to provide the same temperatures within the spray pattern as the non-aerating

head #3C and suggest that #2 would be the preferred aerating head, should one decide to use an aerating head.

**HUMAN COMFORT TESTING**

The showers were then tested by four volunteers under controlled conditions. Each person entered the shower, the water was adjusted until it was too cool for comfort, and was then readjusted until it was considered "comfortable". The temperature of the water entering the shower head was then recorded. Each person's "comfort temperature" was determined twice for each showerhead with a 5-10 minute period between the two determinations. The results are shown in Table 3. Note that #4 was omitted from this test since the earlier results showed it to perform in an essentially identical manner as expected.

It can be seen that #3C requires the lowest water temperature, as expected, based on the results of Table 2 and Table 3. The average temperature required was 98 F. The aerating showerheads required temperatures 4.1-10.2 F higher. However, this time, #1 showed the smallest increase in required temperature. Note that head #3 was also tested adjusted to its finest spray position (#3F) and also required a higher supply

Table 2

Water Temperatures Required by each Head to Produce Temperatures of 101.2 F, 95.9 F and 95.3 F at Distances of One, Two and Three Feet from the Head.

Head	One Ft.	Two Ft.	Three Ft.	Avg.	Diff.
#1	114.6	115.8	130.1	120.2	15.2
#2	110.3	106.9	109.3	108.8	3.8
#3	105	105	105	105	0.0
#4	113.3	114.3	120.6	116.1	11.1
#5	111.4	116.4	120.2	116.0	11.0

Table 3

"Comfort Temperatures" Determined by Four Testers for Different Showerheads

Head	Tester #1	Tester #2	Tester #3	Tester #4	Average
#1	108.5	103	93	105.5	102.5
#2	115.5	109	103	107	108.6
#3C	99	100	94.5	100	98.4
#3F	105	101.5	94.5	103.5	101.1
#5	115.5	106.5	103	108	108.2

Table 4

## Annual Cost Savings Estimates for Aerating Low-Flow Showerheads in Two Prison Facilities

Location	Water & Sewer Savings	Gas Savings	Total Savings
Site 1	\$ 9,489	\$ 1,547	\$ 11,036
Site 2	\$ 11,675	\$ 662	\$ 12,337

temperature than when adjusted to its coarse position (#3C).

#### SAVINGS ESTIMATES FOR LOW-FLOW SHOWERHEADS

The three low-flow aerating showerheads tested appeared to be nearly identical in design and construction. The testing reported in the previous section showed that they consistently required higher supply temperatures than the non-aerating head to produce the same level of temperature and/or comfort in the spray pattern. All three aerating heads produced a flow rate of 1.95 gpm @40 psig within experimental error and the discrepancies between results of the temperature measurements and the comfort measurements suggest that all three will have equivalent operating temperatures.

The testing indicates that the aerating heads can be expected to require water at approximately 115 F to achieve the same spray temperature as that provided by non-aerating heads with 105 F water. The additional energy required to heat the water to 115 F will reduce the gas savings substantially, but the aerating heads still produce net savings of \$ 11,036/yr and \$12,337 at the two prison sites analyzed, based primarily on the water cost savings.

Each facility has 302 showerheads, so the annual savings per showerhead is still \$36 - \$41 per showerhead. The aerating heads themselves sell for less than \$4 per head in quantity, but the heads must be factory assembled onto the built-in shower assemblies used by the prison, so the cost would have to be negotiated with the manufacturers. However, based on the price of the aerating heads, the payback should be two months or less.

#### CONCLUSIONS

The measurements conducted have shown flow rates of 1.95 gpm at 40 psi for the showerheads tested. Hence all models tested would result in water and sewer savings of approximately 22% compared with the models currently used by the prisons. However, energy savings would be smaller if the same comfort levels are achieved, since the circulating water temperature would need to be raised approximately 10 F to achieve the same water temperatures in the shower stall.

While the total cost savings have been reduced by a factor of three from the original estimate, the payback will still be approximately 1-2 months, depending on the price which can be negotiated with suppliers.

This study has raised as many questions as it has answered. Since there is a greater evaporative cooling effect with the aerating nozzles, there will obviously be a difference in results between dry climates and humid climates. There also appears to be an optimum nozzle, one which will combine the low-flow features and minimize the evaporative cooling effects. Further study is recommended.

#### REFERENCES

1. Claridge, D.E., Krarti, M. and Turner, W.D., "Energy Efficiency Design Evaluation for the Texas Department of Corrections," Proc. of Fifty Annual Symposium on Improving Building Energy Efficiency in Hot and Humid Climates, Sept. 13-14, 1988, Houston, pp.129-136.
2. PSEG of New Jersey and Northeast Utilities, Connecticut.
3. Claridge, D.E., Turner, W.D. and Chen, L., "Shower Testing for the Texas Dept. of Corrections", Vol.1, Energy Systems Laboratory, Mechanical Engineering Department, Texas A&M University, August 15, 1989.