

## GROUND-COUPLED HEAT PUMP APPLICATIONS AND CASE STUDIES

Harry J. Braud, Professor

Louisiana Agricultural Experiment Station, Louisiana State University Agricultural Center  
Department of Agricultural Engineering, Baton Rouge, Louisiana

## ABSTRACT

The paper presents an overview of ground loops for space-conditioning heat pumps, hot water, ice machines, and water-cooled refrigeration in residential and commercial applications. In Louisiana, a chain of hamburger drive-ins uses total ground-coupling in its stores. A grocery store has ground-coupling for all heat pumps and refrigeration. Desuperheaters provide 80 percent of the hot water for a coin laundry in the same building. A comparison of energy costs in a bank with a ground-coupled heat pump to a similar bank building with air-conditioning and gas for heat revealed a 22 percent reduction in utility costs for the ground-coupled building. In a retrofit application of ground-coupled heat pumps to replace air-conditioning and electric heat, energy consumption was reduced by 67 percent, and peak kilowatt demand was reduced by 50 percent.

## INTRODUCTION

Rising energy costs have affected all segments of the nation's economy. In the home, space heating and cooling constitute the largest energy use. Water heating is the second energy user. Refrigeration consumes very large amounts of electric energy in businesses such as restaurants, fast food outlets, and food storage and processing.

In cooling and heating processes, the natural environment (either air, water, or earth) is the ultimate source or sink of the heat added to or removed from the material or process. The operating efficiency of refrigeration equipment and heat pumps is a direct function of the temperature of the environmental source or sink. Ground loops allow heat pumps and refrigeration to utilize the most favorable environmental temperature available, that of the earth. Reduction in equipment energy consumption can be achieved with (1) a thermally stable environmental source/sink such as the earth, and (2) an energy recycling system that captures waste heat or cooling effect from one device or process and uses it in another. Both of these features are inherent in closed-loop ground-coupled systems.

Consumers who are charged for electricity at a rate based on peak demand benefit from the flat electric demand curve of the ground-coupled heat pump. This not only helps the consumer who purchases the electricity, but also benefits the utility by reducing the peak power draw on the distribution system and the generating plants. Ground-coupled heat pumps are good for both. Power draw is low and predictable. It is an all-electric system that can save natural gas and other fossil fuels.

Because of the large amount of pipe needed for the ground loop, ground-coupled heat pumps cost more than air source heat pumps. Cost for the ground-coupled heat pump is as much as \$800 to \$1,500 per ton more to install than air source systems. Despite the high cost, over 1,000 homes in Louisiana have ground-coupled heat pumps. Significant energy savings have been documented in numerous residential installations with utility billing reduced as much as 20 to 50 percent compared to air-source equipment and/or gas heat.

## WHY GROUND-COUPLING?

The earth contains an abundant store of heat energy that is replenished annually by the sun. A city lot 100 ft by 150 ft to a depth of 300 ft has enough energy to provide the entire annual energy needs for a household by changing its temperature only 1/6 degree Fahrenheit. It has been said that the greatest solar collector in the world is the earth beneath your feet. The enormous mass of the earth and its stable temperature make it an ideal source/sink for heat pumps. This is because the earth contains much more heat than the atmosphere. Of the thermal energy reaching the earth from the sun, 47 percent is absorbed and stored in the earth. The atmosphere, being much less dense and transparent to thermal radiation, absorbs only 19 percent (Figure 1). Heat absorbed by the earth in summer provides a free heat source the next winter. Ground-coupled heat pumps tap this free energy. They deliver what solar collector systems only promised. Instead of looking up to the sun, we need to look down to the earth for the free heat stored there.

## DISTRIBUTION OF INCOMING RADIATION

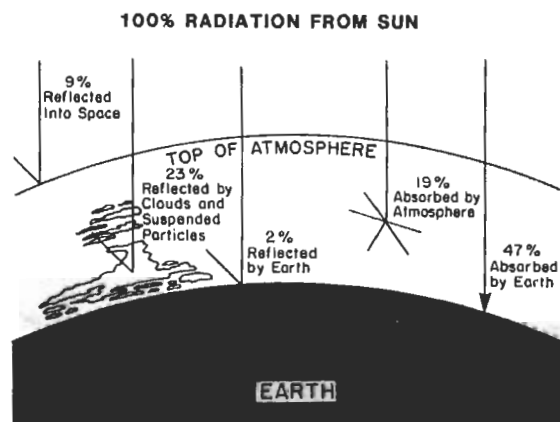

Figure 1. Distribution of solar energy to earth.

Air-source heat pumps have some drawbacks because there is less heat in the atmosphere than in the earth. Both the heating capacity and efficiency decrease as the outdoor air temperature falls. During the coldest days of the year, they must be assisted by electrical resistance heating elements. This supplemental heat increases electricity demand, thereby adding to utility load requirements. Ground-coupled heat pumps maintain full heating capacity and high performance during cold weather. They are able to deliver their rated heating capacity regardless of the outdoor air temperature because the heat pump only knows the warm earth temperature brought to the unit by the loop water circulation. Besides, water is far superior to air to deliver heat at any temperature. The thermal capacity of a cubic foot of water is 62.4 Btu for a 1°F temperature change versus 0.018 Btu for a cubic foot of air. Ground-source heat pumps do not have a defrost cycle. Defrost is the main cause of service calls in air-source heat pumps.

The economic impact of ground-coupled technology is truly unique. It is not sophisticated, high technology. It is good for local business. A new trade - ground loop contracting - is needed to provide the ground-coupling. Bore drilling gives work to small water well drillers. Pipe installation, trenching, and other loop work use small contractors and local labor. The dollars the customer invests in the ground-coupling feed the local economy instead of paying for a new large distant electric power plant. It seems reasonable to expect that this technology will now develop a momentum of its own and spread widely and rapidly into the commercial field.

Elimination of outdoor mechanical equipment is a definite advantage in both residential and commercial construction. Equipment life in the outdoor environment is short due to snow, rain, and dust. Where space is at a premium, elimination of outdoor equipment is not only a cost-saving factor but also an aesthetic one.

Ground-coupled heat pumps have been installed in several old plantation houses in Louisiana. The decision to use ground-coupling is a matter of preserving the historical value. A notable installation is the Oakley Plantation House, near St. Francisville, Louisiana, where the famous artist and painter John James Audubon lived.

"Preserving the architectural integrity of Oakley Place Plantation, the historic home where American artist and naturalist, John James Audubon lived and painted in Louisiana, was foremost in the mind of Baton Rouge architect, James D. Dodds, AIA, when he decided to utilize earth-coupled heating and cooling to solve the humidity problem threatening first edition Audubon prints, furnishings and artifacts. By going with an **in-ground closed loop** system, there will be no unsightly **air conditioning compressors** peeking behind lush foliage, and **no vents or ductwork** inside to disrupt a visitor's impression of having stepped back in time. Dodds worked out a system which runs pipe from the ground coil up the gutter spouts of the three story colonial structure to the attic which houses the water source

heat pump. Air conditioning and heating are then dispersed throughout Oakley by running pipes down through the chimneys in each room. Inside and out, the Twentieth Century is held at bay so that tourists will continue to view Oakley Place much as Audubon did when he arrived there in 1821."

Along These Lines, Feb. 1986.  
Dixie Electric Membership Corp.  
Baton Rouge, Louisiana

#### GROUND-COUPLED HEAT PUMP ENERGY FLOW

Energy transfer in a ground-coupled heat pump involves four media: indoor air, the refrigerant gas, water in the loop, and the earth mass (Figure 2). Energy must pass through three heat exchangers: the indoor air-to-refrigerant coil, the refrigerant-to-water coil, and the water-to-earth pipe wall.

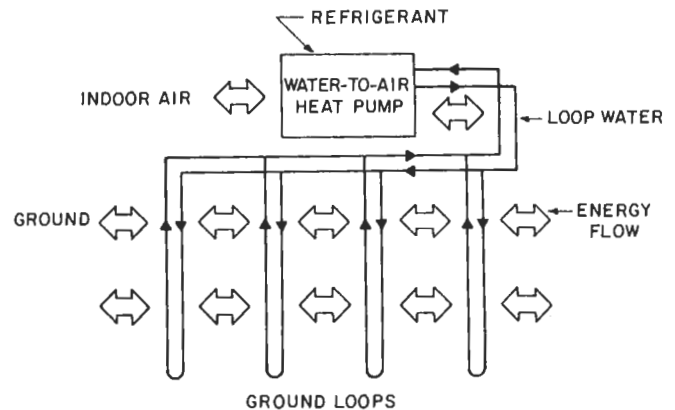

Figure 2. Ground-coupled heat pump.

In the cooling mode, thermal energy flows from the indoor air to the refrigerant, to the loop water, and to the earth. Electric energy that powers the compressor enters the refrigerant gas as heat of compression and sensible heat from the motor and passes on to the earth. The total heat rejected to the earth is the sum of the heat absorbed from the indoor space plus the electric energy needed to power the compressor. In the heating mode, the compressor heat energy goes to the indoor air along with heat absorbed from the earth. For every unit of electric energy needed to drive the heat pump compressor three to four additional units of heat energy are absorbed from the earth.

A ground loop can take thermal energy rejected by one device and deliver it to another that requires heat. Energy transfer to or from the earth stabilizes loop water temperatures and satisfies energy balances. Loop length must be adequate to provide safe loop water temperatures for all units in all seasons. A loop sizing procedure for multiple units on a common ground loop was given by Braud (1). See also Bose et al. (2) and Partin (3).

## APPLICATIONS OF GROUND-COUPLED HEAT PUMPS

### Ground coupled refrigeration

A recent development in ground loop technology is to use a ground loop for refrigerators, freezers, display cases, and ice machines. These machines can even be put on the same ground loop with a heat pump. Water-cooled condensing units are more efficient than air-cooled, and they can be put indoors. Indoor location makes piping for desuperheater hot water easy. Since refrigeration equipment runs more than heat pumps, energy savings can be very large for ground-coupled refrigeration. In Louisiana, over forty office buildings are on ground loops. Systems vary from small offices to a three-story office building with 187 tons. Many commercial systems have both refrigeration and heat pumps. A chain of hamburger drive-ins, uses total ground-coupling in all of its outlets. A grocery store has ground-coupling for all heat pumps and refrigeration. Desuperheaters on all units provide 80 percent of the hot water for a coin laundry in the same building. Another grocery store with 15 tons of load (11 tons in heat pumps for space conditioning plus four tons of refrigeration) is served by a 200 amp, 115/230 volt single phase service drop. The 6000 ft building also contains a seafood market and an auto repair shop all on the 200 amp service. Pool heating systems and water heating for a car wash can also be found.

### Desuperheaters

A desuperheater coil on a water source heat pump, Figure 3, is a cost-effective device. Heat extracted from the hot compressor gas can provide most or all of the hot water in a residence. When the heat pump is in space cool mode, heat removed from indoor space goes to the hot water tank and to the earth simultaneously until the hot water tank is satisfied; then the earth heat exchanger must provide the entire heat rejection. In winter, earth source heat provides both water heating and space heat. The reduction in space heating capacity due to hot water energy is not severe with a water source heat pump drawing on earth energy, as heating 60 gallons of water (average daily hot water use) from 50°F to 150°F requires only 5000 BTU. Desuperheaters can be used on both air-cooled and water-cooled refrigeration condensing units. However, water-cooled condensing units are usually located indoors, which makes hot water piping easy.

In commercial applications, heat pumps run long hours, and desuperheaters can provide very large quantities of hot water. Pierce (4) found that a restaurant using 500 gallons of hot water per day was able to save \$3,156 a year on hot water costs with desuperheaters on a total of 10 tons of refrigeration condensers. Pierce stated that desuperheaters have a fast payback, generally from 8 to 36 months in restaurants and fast food outlets. Other benefits are simple equipment with no moving parts, reduced electric demand, more efficient compressor operation, and increased refrigeration capacity.

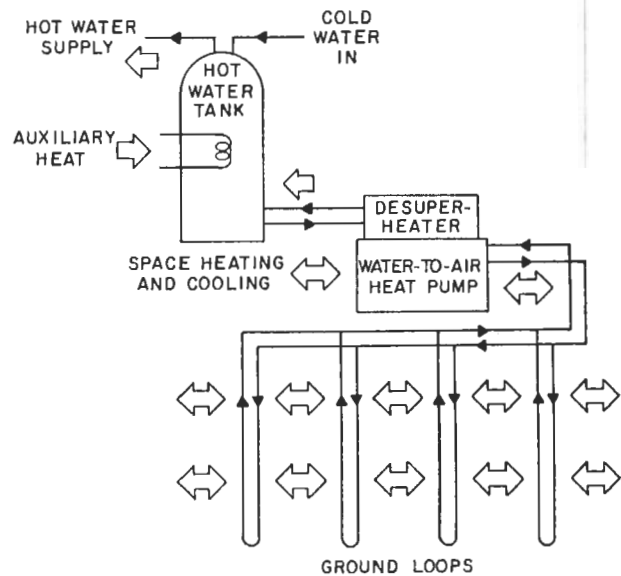

Figure 3. Ground-coupled heat pump with desuperheater.

A grocery store in Gonzales, Louisiana has desuperheaters on the ground-coupled heat pumps and refrigeration condensers. Enough hot water is produced to provide 80 percent of the hot water for a coin laundry in the same building.

A 4 ton heat pump in a Baton Rouge office has generated enough hot water for restrooms and a small kitchen so that the electric elements have never been energized since installation in 1981. Desuperheaters on a 3 ton heat pump in a fast food outlet produces all the hot water needed for the kitchen.

### Heat pumps and refrigeration on a ground loop

Ground loops offer several advantages for businesses that have large refrigeration loads as well as heat pumps. Restaurants, fast food outlets and grocery stores are examples.

All heating and cooling units can be put on the ground loop. Water-cooled condensing units for refrigerators and ice machines operate much more efficiently on water, and **all** mechanical equipment can be put indoors. Besides inherent energy recovery and transfer, a total ground loop system has very little maintenance and obvious aesthetic advantage. Elimination of outdoor condensing units and cooling towers reduces land requirement. Air-cooled roof top units operate in a harsh environment and create roof leaks and noise problems.

Two grocery stores in Louisiana use the total ground-loop concept as shown in Figure 4. A 6,000 sq ft store with 11 tons of heat pumps and a 4 hp refrigeration load has a 200 amp, 115/230 volt, single phase electric service to serve the whole building that also contains an auto repair shop

and a small seafood market. This is the same size electric service used for a residence.

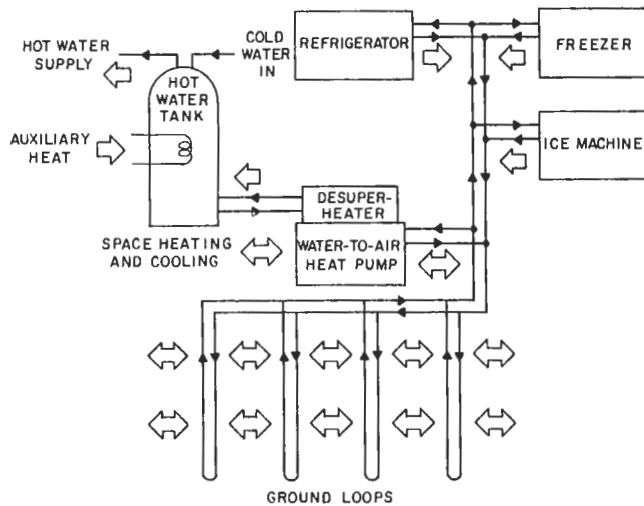

Figure 4. Ground-coupled heat pump and refrigeration.

Refrigeration heat rejection to a ground loop is always beneficial to heating devices sharing the loop. In zones of cool earth temperature, the capture of refrigeration waste heat would improve seasonal heating performance efficiency of heat pumps. Having access to earth temperatures year-round allows water-cooled refrigeration units to operate very efficiently. It would seem that in any climatic zone where annual heating energy exceeds cooling energy, refrigeration heat rejection would be highly beneficial. Loop energy transfer from cooling devices to heating devices would occur in many hours of the year. Loop length and cost could possibly be reduced for combined loads. It is interesting to note that combined heat pump/refrigeration loops are being installed in south Louisiana where earth temperature (70°F) is relatively warm and space-cooling mode dominates. The capture and recycling of refrigeration rejected heat is an energy resource that should be recognized and exploited, especially in the central and northern regions of the United States.

## RESIDENTIAL APPLICATIONS OF GROUND COUPLED HEAT PUMPS

Earth-coupled water-source heat pump systems are expensive (\$800 to \$1,500 more per ton than conventional systems) because of the large amount of pipe needed for the ground loop. Nevertheless, long life and low maintenance and operating costs make them a good investment.

The space conditioning system is a "big ticket" item in the typical family budget. Smilie et al. (5) compared five 3-ton space conditioning systems (Table 1). The analysis included installation costs and the operating costs derived from weather data and costs for gas and electricity. Maintenance cost was assumed to be \$50/year except for air-to-air heat pumps, for which it was assumed to be \$70/year.

Inflation of energy and maintenance costs was estimated at 5%/year.

Low initial cost for equipment usually means high operating costs. The earth-coupled water-source heat pump system had the lowest 10-year total cost, \$12,840, even in comparison to a high efficiency air-conditioner and high efficiency gas furnace, \$14,082, (Table 1).

Table 1. Summary of costs of five heating and cooling systems Three-ton capacity. Baton Rouge, LA (Smilie et al.) (5)

System	Installation Cost	Operating Cost	10-Year Total Cost
1. Air conditioner, 8.65 EER, electric heat	\$2500	\$1740	\$19,903
2. Air conditioner, 9.15 EER, gas furnace @ 55% efficiency	2900	1294	15,836
3. Air-to-air heat pump, 9.02 EER, 3.05 COP	3300	1308	16,378
4. Air conditioner, 11.00 EER, gas furnace \$ 95% efficiency	3500	1058	14,082
5. Earth-coupled water-source heat pump, 11.1 EER, 4.01 COP	4730	969	12,840

### Residential case studies

In 1981, the author replaced a 4-ton air-conditioner and gas furnace in his home with a ground-coupled heat pump. It reduced his electric bill by 21 percent and eliminated the gas service and bill. Instead of the heating and air-conditioning consuming half the annual total utility use, the heating and cooling amounted to only 22 percent. Heat recovery from the heat pump reduced hot water energy to only 13 percent of the total, while the electric clothes dryer consumed 14 percent annually. Based on actual electric and gas rates, 1981-86, the family's utility bill has been reduced by an average of \$580 per year. Cost premium for the new system was \$2,200 over the replacement cost for the air-conditioner and gas furnace. In simple figures, the payback was less than four years, Braud (6). In another test residence, an earth-coupled water-source heat pump reduced the overall residential electric use by 28 percent.

### COMMERCIAL BUILDING APPLICATIONS

In Baton Rouge, Louisiana, two bank buildings were equipped with ground-source heat pumps in one and conventional air-conditioning and gas heat in the other. The ground-coupled building was slightly larger--3,300 ft vs 3,000 ft--than the building with the air conditioning and gas.

The ground-coupled bank required 15 tons of capacity versus 11.5 tons in the other. Energy use in the ground-coupled building was 52,368 kWh less in the twenty-three-month period Aug. 1985 to June 1987 than in the building that has air-conditioning and gas, Table 2. Gas consumption in the bank with gas was 689 ccf for the billing period. Total utility billing for the ground-coupled bank was \$12,233.09 versus \$15,688.11 for the air-source with gas, a 22 percent difference.

The Mississippi Power and Light Co. compared ground-coupled heat pumps to high-efficiency air-source heat pumps in two of its office buildings. The two offices each have 11,500 ft of conditioned area, similar operating schedules, and the same insulation. Additional cost for the ground-coupled system over air-source was \$835 per installed ton. Peak kilowatt demand was 120 in the air-source building and 78 in the ground-coupled building, Table 3. Energy use was 590,640 kWh in the air-source and 445,600 kWh in the ground-coupled, a 25 percent difference, in a 21-month period, October 1985 - June 1987. Average kilowatt demand per month was 93 in the air-source building and 65 in the ground-coupled building.

In a retrofit application, ground-coupled heat pumps reduced electric energy consumption 67 percent. A state agency installed 30 tons of ground-coupled heat pumps in a field office in Hammond, Louisiana to replace electric resistance heat and an air-cooled chiller. In the first year of operation, the ground-coupled system used 394,320 kWh less, Table 4. Peak kilowatt demand with the electric heat and air-conditioning was 125 kw versus 63 with the ground-coupled heat pumps. The utility costs were reduced by 58 percent, \$34,883.08 versus \$14,627.90. Based on these figures, the owner is expecting a 2 to 3 year payback on the cost for the entire change-out of the building's equipment. The old system required a \$5,000/year maintenance contract on the pneumatic control system that is not needed with the ground-coupled heat pumps.

## CONCLUSIONS

### Advantages of a ground-coupled heat pump system

1. Energy savings of 20 to 50 percent over air-source equipment. Electric demand is also reduced with water-cooled condensing units for refrigeration and heat pumps.
2. Elimination of all outdoor condenser units - also cooling towers and boilers. Corrosion, dirt, vandalism, theft, high maintenance, and freeze problems are eliminated. Elimination of roof top units reduces roof maintenance, damage, noise, leaks, etc.
3. **No outdoor space required.** Earth bores can be put under lawns, landscape zones, driveways, and parking lots. **A three story building in Baton Rouge, Louisiana has all bores underneath the building.**
4. **Free hot water generated** with desuperheaters during the summer months, year-round with refrigeration

waste heat. Hot water produced with COP advantage from earth source in the winter.

5. No depletion of ground water. Presence or quality of ground water is of no concern because heat transfer is to the earth mass.
6. No wastewater expense or disposal problem. Closed loop uses ordinary tap water for heating and cooling energy transfer to earth.
7. Elimination or reduction in electric heat strips that are required with air-source heat pumps.
8. Elimination of gas service to premises. No flue or ancillary costs for gas heat that are often hidden in the plumbing contract.
9. Long life, low maintenance system. Recent trade figures indicate that water-cooled condensers have 20 + year life expectancy. Compressor life is long because of low head pressure when operating with water.

### Disadvantages

1. High initial cost - \$600 per ton for earth bores in Louisiana. Manifold piping, pumps, etc. will increase total cost to \$800 to \$1500 per ton over other types of air-conditioning systems.
2. Not all air-conditioning contractors are familiar with this technology.
3. Earth drilling is difficult in rock or other problem areas.

## REFERENCES

1. Braud, H.J. 1986. Ground loops for heat pump and refrigeration. Building energy symposium. Mechanical Engineering Department, Texas A&M University.
2. Bose, J.E., J.D Parker and F.C. McQuiston. 1985. Design/data manual for closed-loop ground-coupled heat pump systems. American Society of Heating Refrigeration and Air-Conditioning Engineers. Atlanta.
3. Partin, J.R. 1981. Closed-loop earth-coupled heat pump exchangers. Ground Water Heat Pump Journal. Water Well Journal Publishing Co., Worthington, Ohio.
4. Pierce, J.R. 1983. Refrigeration-to-water heat exchange. The Consultant. Food Service Consultants Society International. Seattle, Washington.
5. Smilie, J.L. et al. 1984. An economic comparison of the earth-coupled water-source heat pump with other methods of heating and cooling. Louisiana State University Cooperative Extension Service. 31p.
6. Braud, H.J. 1984. Earth-coupled heat pumps for residential heat/cool and hot water. **7th Heat Pump Technology Conference, Oklahoma State University. 7p.**

Table 2. Comparison of ground-coupled heat pumps to air-conditioning and gas heat.

Baton Rouge Bank August 1985 to June 1987					
Branch	KWH	Elec. Billing	CCf	Gas Billing	Total
Jones Creek Branch A/C and Gas Heat	248,928	\$15,337.61	689	\$350.50	\$15,688.11
Perkins Branch - Ground Coupled Heat Pump	196,560	\$12,233.09	0	\$0.00	\$12,233.09
Difference	52,368	\$3,104.52	689	\$350.50	\$3,455.02
Percent	21%	20%	-	-	22%

Table 3. Comparison of ground-coupled pumps to air-source heat pumps.

Mississippi Power & Light Co. Jackson, MS. October 1985 to June 1987				
Average Office	Average Max KW	Total KW	Kwh/Month	Kwh
Rankin Office - Ground-Coupled Heat Pumps	78	65	21,219	445,600
Madison Office - Air-Source Heat Pumps	120	93	28,126	590,640
Difference	42	28	6,907	145,040
Percent	35%	30%	25%	25%

Table 4. Comparison of ground-coupled heat pumps to replace air-conditioning and electric heat.

Louisiana Department of Employment Security Hammond, LA					
System	Average Max Kw	Average Kh	Total Kwh	Total Kwh	\$
Ground-coupled heat pumps March 87 to Feb. 88	63	54	16,350	196,200	14,627.90
Air-conditioning and electric heat March 86 to Feb. 87	125	115	49,210	590,520	34,883.08
Difference	62	61	32,860	394,320	20,255.18
Percent	50%	53%	67%	67%	58%