

## Discussion of Air-Conditioning Energy-Savings in Hot-Summer and Cold-Winter Regions

Wenheng Zheng  
Docent

Fuhua Gong      Xiaotie Lou      Jiao Cheng  
Adjunct Professor      Senior Engineer      Doctor  
Hunan Institute of Engineering  
Xiang'tan & China  
zhengwenheng@sina.com

**Abstract:** Introducing several kinds of air-conditioning systems energy conservation measures, and according to the climate of the hot-summer and cold-winter region in China, this paper puts forward an overall conception for air-conditioning energy-savings at this area. Namely, we may use the combination of evaporative cooling, dehumidifier and mechanical cooling to save energy for air-conditioning.

**Key words:** hot-summer and cold-winter; energy saving; evaporative cooling; dehumidification

### 1. INTRODUCTION<sup>[1~2]</sup>

The main subarea index of hot-summer and cold-winter is the most cold month mean temperature 0~10 °C, the most hot month mean temperature 25~30 °C. That region includes Chongqing, Shanghai 2 municipality directly under the Central Government; Hubei, Hunan, Anhui, Zhejiang, Jiangxi 5 province all; Sichuan, Guizhou 2 province eastern; Jiangsu, Henan 2 province south half departments; north half in the province of Fujian; south of Shanghai, Gansu 2 province; Guangdong, Guangxi 2 province area norths carry. That region involves the southwest region eastern region and middle and backward position of the Changjiang River which has 16 province, municipality and municipality directly under the Central Governmen, about 500,000,000 population, citizen's total output value invites occupy national 48%, is a Chinese population the most intensively, the economy develops the flat-out and quickest region.

At the end of 20 centuries, using electric heating devices in winter and using air conditioner in summer have grew into fashion. In many big cities, the possession rate of air conditioner has already exceeded 80%, and have been faced by a door per set

developed a room a pedestal or door central air-conditioning, the energy consumption of air-conditioning is astonishing. At the Family who possesses air conditioner, the air-conditioning inputs electric power is skimp 1kW or amounting to 3~4 kW. The family air condition uses the main power supply that give an electric shock in summer in living quarter carries is the enormous threat to provide the normal movement that go together with give or get an electric shock the system. In some living quarters, provide to go together with to give or get an electric shock system to increase to permit to change the line year by year, but not yet catch up the air-conditioning increase speed. Year by year heat weather can't normal supply power, serious, a hour restrict the use of electricity several times, into an electric voltage not enough 180Vs, resulting to over 20% electric power is wasted on the power supply circuit, and endanger the power supply circuit the safety. In recent years, the air-conditioning that our country add annually packs the machine capacity nears to even exceeded the same period new set up the power station pack the machine capacity. Current, at many developed citys, the air-conditioning consumes 40% or so of the electric power at high peak period. This is the main reason to cause " restrict the use of electricity ".

In hot-summer and cold-winter area, using air conditioner to heating basically utilizes electric power. For make that region of public and the industry uses the building the widespread attaining the hot and comfortable level, air-conditioning uses the electricity carries 80,000,000kW in summer and 200,000,000kW in winter which is equivalent to the year of equal to the deal of 11 Yangtse gorges power station generating electricity. Obviously this

will become the one of the nervous main reasons in the river valley electric power of Yangtze River, will seriously hinder the Yangtze River river valley society the economic keeping on the development. At the same time, because of bearing to highly consume electricity power, if do not open the exhibition air-conditioning system economize on energy, the hot-summer and cold-winter area is impossible to get the widespread improvement. According to the analysis, to realizes completely middle-class family society in 2020, our country air-conditioning peak load stanza electricity space roughly 90,000,000 Kw, equal to 5 Yangtse gorges the electricity stands full burthen capacity, is national that programming inside 2020 electricity the gross packs the machine capacity of 2~3 times, the cowgirl can reduce electric power developments invest more than ¥400,000,000,000. SO the air-conditioning economy energy not only is the good matter that benefits country and benefits people, but also is a big having for economy energy realm.

## 2. ENERGY-SAVING MEASRUE OF AIR-CONDITIONING

### 2.1 Heat Recovery Device<sup>[3]</sup>

The heat recovery device is that makes use of energy of air draft to proceeding to prepare cold or prepare heat outdoor air so that minish outdoor air load to attain air-conditioning economy energy. The heat recovery device of HV&AC system primarily includes: toatal heat-exchanger of wheel, sensible heat-exchanger of plate, toatal heat-exchanger of plate, heat-exchanger of heat-pipe etc.

The toatal heat-exchanger of whee utilizes aluminum which is sprayed lithium chloride and special paper...etc material that is maked into the beehive form, and shape is wheel. Outdoor air passes first half of wheel and indoor air passes second half department. In winter, temperature and humidity of indoor air is higher than that of outdoor air. So, when indoor air pass wheel it makes temperature and humidity of wheel material go up. When material turns to contact outdoor air it lets out quatiy of heat and moisture to outdoor air. This leads to outdoor air increase temperature and wet. In summer, the air

transmits heat and spreads the quality process is exactly the opposite. Material of sensible heat-exchanger of plate is aluminum which makes it only exchange sensible heat. Material of total heat-exchanger of plate is special paper. When existing difference in temperature and differential pressure they may transmit heat and spread the quality.

### 2.2 Air-Conditioning System of Temperature and Humidity Independent Control<sup>[4]</sup>

At current, concentric air-conditioning uses exit temperature 5~7 °C or more cold water as cold medium which deals with air. This is because the demand of air dehumidify. But if only for reducing the heat, adopt exit temperature 18~20 °C as cold source that can satisfy the request. However wet load generally account for air-conditioning load only 30%~50%. As a result a great deal of sensible heat load are handled by cold medium in such low temperature that causes the cold source efficiency lowly. So, air-conditioning system of temperature and humidity independent control has become an important direction in recent years. Send outdoor air into the indoors after dehumidity that can dissolve the indoors produce wet and combine to satisfy the fresh air request. But using the independent system of water makes 18~20 °C cold water to circulate, via radiation or convection bitter ends to dissolve the indoors sensible heat. This can avoid when condensation dehumidity cold and heat counteract and can also use high temperature cold source absorb sensible heat, and make cold source efficiency significantly increase. This kind of way at the same time can also effectively reform indoor air quantity.

### 2.3 Building Combined Heating & Power Generation<sup>[4]</sup>

When the natural gas becomes the city primarily once energy, comparing with in brief direct burnable way, adopting the motive equip to be generated electricity by the combustion gas first, then use the remaining heat after generating electricity that provide to building heat or afford motivity of refrigeration in air-conditioning system, which can acquire the higher fuel utilization efficiency. This is

the so-called BCHP:Building combined heating& power generation.This kind of way pass to let large building generated electricity by oneself, solving the most electricity load, increasing to use electricity securitily, at the same time reducing load of transmit electricity and distribution,and decreasing loss of the long distance transmit electricity( in industry country this loss occupy the electricity measures 8% ~10%).

#### 2.4 Evaporative Cooling Air-conditioning System<sup>[5-6]</sup>

Evaporative cooling uses water as refrigerant, because of doing not use the CFC, as a result is free from pollution to the atmosphere environment, and can adopt the all outdoor air that improves the indoor air quality greatly. The refrigeration principle is similar to usual machine refrigeration system namely it gets the cold from the evaporation of refrigerant.But evaporative cooling obtains energy by water evaporating.So it need not vapor to proceed the compression and condensation to liquid water again, and proceed the evaporation. Generally, we can add the water directly to maintain the process to the evaporation proceeding. Comparing with the mechanical refrigeration, in evaporative cooling air-conditioner there only fan and water pump need power, others have no need to input energy.So the value of coefficient performance COP is very high ( about is the mechanical refrigeration 2.5~5.0 times) . Usually the mechanical refrigeration system packs machine power is  $50\text{W}/\text{m}^2$  or so, but evaporative cooling system is  $10\text{W}/\text{m}^2$  or so. Evaporative cooling can economize electric energy 80% or so.Evaporative cooling do not need the depletion of compress work, accordingly acquire the result of the energy svaing.

### 3. A KIND OF AIR-CONDITIONING SYSTEM THAT BE APPLICABLE TO HOT-SUMMER AND COLD-WINTER REGION

Hot-summer and cold-winter region in our country because of special geography position it forms the weather characteristic,that is air temperature is high in the summer.Number of days of air temperature higher than  $35^{\circ}\text{C}$  is 15~25,and at the most hot day air temperature can amount to  $41^{\circ}\text{C}$

above, and the degree of humidity is big so it gives the sultry felling in person. But the winter is wet cold, and the number of month of the temperature lower than  $5^{\circ}\text{C}$  can amount to 2~2.5, and the lowest temperature can reach- $18^{\circ}\text{C}$  . Furthermore the sunshine rate is very low, and the overcast and rainy day is many, such as the sunshine rate in the winter is 13% of ChongQing, 21% of ChengDu, 27% of ChangSha, 39% of WuHan, 47% of Nanking,43% of Shanghai, but Beijing is up to 67%<sup>[7]</sup>. At the whole year, the high humidity is the prominent feature of the region's weather, and average relative humidity in main city in that region is in 75%~80% or so.Sometimes it can be up to 95%~100%, and monthly amplitude of relative humidity is 10% or so. According to the month average relative humidity being 70% as the simple distinguishes index, hot-summer and cold-winter region belongs to the typical humid climate region<sup>[8]</sup>. The writer draws lessons from the above air condition economy energy measure, and according to the actual circumstance of hot-summer and cold-winter region, putting forward a kind of air-conditioning system project that is applicable to that region,showing af Fig1. The system uses the combination of evaporative cooling, dehumidifier and mechanical cooling. The new air machine undertakes the load of outdoor air and indoor air,and adopting whole air system, having no recirculated air.Between outdoor air and air exhaust we adopt toatal heat-exchanger.And high efficiency filter conbies with padding direct evaporative cooler so as to increasing the air filters efficiency;At the same time system adopts VAV control system.

That system is a new air in economy energy air-conditioning system that can be used both in summer and in winter.The design thought of the system is according to the characteristics of hot-summer and cold-winter region, giving full play to predominance of evaporative cooling and technique of dehumidity in the air-conditioning system energy saving, and combining to total heat-exchanger and VAV control system, thereby lower the air-conditioning system energy consumption. Because in the hot-summer and cold-winter region, the outdoor air temperature is not high, but the weather process of very high humidity appears time

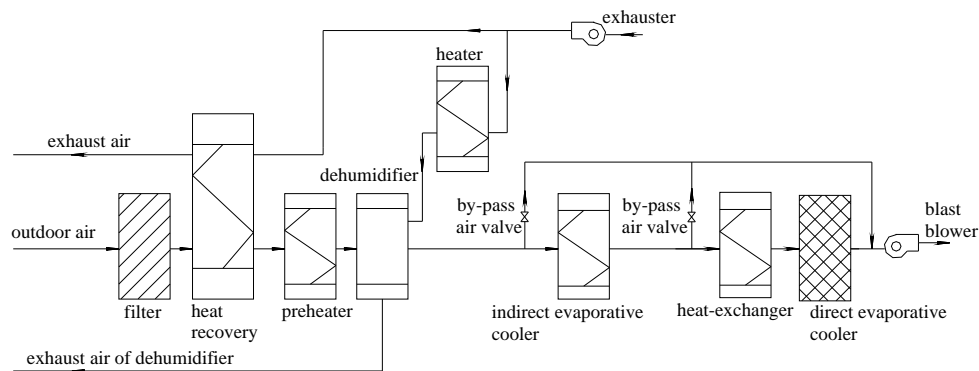

Fig. 1 Air-conditioning system that be applicable to hot-summer and cold-winter region

longer, such as transition season and overcast and rainy in summer. At this period, if we directly send the outdoor air into the indoor, it will cause the indoor air humidity exceed the upper limit value of the hot environment quantity standard provision, and affect the hot environment in indoor, make live feel sultry and discomfort, break hot comfort feels of human body and the air quality. At this time they are usually not needed to be reduced the heat but needed to be dehumidified. Therefore, by-pass air valve will directly send outdoor air to blast blower. The total heat-exchanger adopts wheel. The indirect evaporative cooler can adopt the cooling tower providing cold type, heat-exchanger of plate type, heat-exchanger of tubular type or heat-exchanger of heat-pipe type, also can adopt multi-stage evaporative cooling. Direct evaporative cooler can both adopt the filter type and adopt air-washer type. Cold water or hot water in the heat-exchanger is offered by heat-pump.

#### 4. EPILOGUE

Along with building trades and market economy development, HV&AC system has been able to extensive use, energy consumption used for HV&AC system will further enlarge, this certainly will turn worse the energy supply and demand contradict further. Therefore, the economy energy system of HV&AC will become the main development trend in the future. But evaporative cooling technique combined with dehumidity, mechanical refrigeration, energy recovery, and VAV air-conditioning energy-saving system will exert the obvious advantage in hot-summer and cold-winter

region, and have the widely applied foreground.

#### REFERENCES

- [1] Xiangzhao Fu. Energy-saving technology of building in hot-summer and cold-winter region. Beijing[M], China Architecture & Building Press, 2002, 1-45. (In Chinese)
- [2] Yanbing KANG. Some consideration about air-conditioning energy-saving key step[J]. Jie Neng Yu Huan Bao, 2004, (7): 4-6. (In Chinese)
- [3] Yunkun Zhang, Dong Liu. Energy storage- e, heat recovery technology and those application on air conditioning systems[J]. Energy conservation technology, 2003, 21(3): 28-30. (In Chinese)
- [4] Yi Jiang. Current building energy consumption in China and effective energy efficiency measures[J]. HV&AC, 2005, 35(5): 30-40. (In Chinese)
- [5] Meijun Peng, Chengqin Ren. Present situation and application study of the indirect evaporative cooling technology[J]. Refrigeration and Air—Conditioning, 2005, 5(2): 1-5. (In Chinese)
- [6] Xiang Huang, Ming Liu, Xiangyang Yu. Study of evaporative cooling application condition in XingJiang area of China[J]. Refrigeration and Air—Conditioning, 2001, 1(6): 33-38. (In Chinese)
- [7] Xiaoping Yu, Xiangzhao Fu. Analysis of the whole year operating condition of dwelling building's new air system in hot—summer and cold-winter region[J]. Journal of Chongqing Jianzhu University, 2001, 23(2): 35-39. (In Chinese)