

Optimal Outside Air Control for Air Handling Units with Humidity Control

Gang Wang, PhD
Research Associate Professor

Mingsheng Liu, PhD, PE
Professor

University of Nebraska – Lincoln
Omaha, Nebraska, USA

Abstract: Most air handling units (AHUs) in commercial buildings have the (air) economizer cycle to use outside air for free cooling under certain outside air conditions. Ideally the economizer cycle is enabled if outside air enthalpy is less than return air enthalpy. During the economizer cycle, outside air flow is modulated to seek mixed air temperature at a supply air temperature set point. Since the outside air may be dry during the economizer cycle, humidification is required for AHUs with humidity control. As a result, the economizer cycle saves cooling energy but requires excessive steam for humidification. Therefore the economizer cycle may not be economical. An optimal outside air control method is developed to minimize the total cost of mechanical cooling and steam humidification. The impacts of chilled water price, steam price, and space minimum humidity set point are analyzed. Finally the optimal outside air control zones are presented on a psychrometric chart under differential energy price ratios and minimum indoor humidity set points.

INTRODUCTION

The purpose of air handling systems is to create a healthy, comfortable indoor environment. Cold air is typically provided in commercial buildings year-round to eliminate space internal heat gain generated by electronic equipment, building lighting systems and occupants. Meanwhile, fresh outside air ventilation is required for indoor air quality. During summer, warm outside air has to be maintained at a minimum design level using the minimum outside air cycle in order to reduce mechanical cooling energy. On the other hand, the (air) economizer cycle uses cold outside air to reduce or eliminate mechanical cooling during winter. During the economizer cycle, return air and outside air dampers are modulated to seek mixed air temperature at a supply air temperature set point, typically 55 to 60 °F (ASHRAE 1999). High-limit shutoff control is chosen to automatically convert the economizer cycle to the minimum outside air cycle when outside air intake no longer reduces cooling energy usage (ASHRAE 2001).

ASHRAE (2001) provides several high-limit shutoff control methods for economizer operation.

The ideal high-limit shutoff control is enthalpy control. The economizer cycle is disabled when outside air enthalpy exceeds fixed enthalpy, which is the air enthalpy at 75°F dry bulb temperature and 50% relative humidity, or return air enthalpy, which is measured by a return air enthalpy sensor. Actually the ideal enthalpy control only works for AHUs equipped with a spray chamber, where hot and dry air can be treated to cold and humid air through an adiabatic process without any energy consumption. Since most AHUs use a chilled water cooling coil, mechanical cooling has to be used if the mixed air temperature is higher than the supply air temperature set point. Electronic enthalpy control is developed for this case. The high-limit shutoff curve for electronic enthalpy control is a curve that goes through a point at approximately 75 °F dry bulb temperature and 40% relative humidity and is nearly parallel to dry bulb temperature lines at low humidity levels and nearly parallel to enthalpy lines at high humidity levels. However, the accuracy of both enthalpy controls depends on air humidity measurement. Unfortunately, malfunction of air humidity sensors usually makes both enthalpy controls unreliable. In order to eliminate the air humidity measurement, the dry bulb temperature control is developed based on an annual average outside air enthalpy curve with outside air dry bulb temperature. With dry bulb temperature control, the economizer cycle is enabled if the outside air temperature is below a high temperature limit, typically around 65°F.

Overall the economizer can significantly reduce AHU cooling energy consumption. However, it also lowers the indoor humidity level due to dry outside air in the winter. Commercial buildings such as hospitals, museums, libraries and data centers have critical indoor humidity requirements (ASHRAE 1999). Hospitals should be maintained at a relative humidity of 30%. Museums and libraries require a minimum relative humidity of 40% for Class A and B. The minimum humidity level is typically set at 40% for highly sensitive data center equipment (ASHRAE 2004; Chu et al. 2006). To maintain required comfort in a space, humidifiers are typically used to compensate for low outside air humidity.

Sensible (cooling) and latent (humidification or dehumidification) loads of outside air can be expressed in a normalized format (Btu/h-CFM) based on outside airflow. Figure 1(a) shows normalized sensible load contours based on 75°F indoor air temperature. Figure 1(b) shows normalized latent load contours based on indoor relative humidity between 40% and 50%. The outside air can provide free cooling when its temperature is lower than the indoor air temperature. Meanwhile steam humidification is required when the outside air humidity ratio is below the minimum indoor humidity ratio set point. Therefore, extra humidification energy may eliminate the energy savings from free cooling and eventually make the economizer cycle uneconomical. The optimal outside air control should ensure that cooling savings are not lost due to

excessive humidification (Chu et al. 2006; Saman and Johnstone 1996). To avoid steam humidification, an air economizer is not recommended for buildings with a high minimum humidity set point, such as data centers and museums (ASHRAE 1999).

The purpose of this paper is to explore an optimal outside air control method for cost-efficient economizer operation. An optimal outside air control is developed to minimize the total cost of mechanical cooling and steam humidification for a typical AHU with a chilled water cooling coil and a steam humidifier. The impacts of chilled water price, steam price, and minimum indoor humidity set point are analyzed. Finally, optimal economizer high-limit shutoff curves are presented on a psychrometric chart under different energy price ratios and minimum indoor humidity set points.

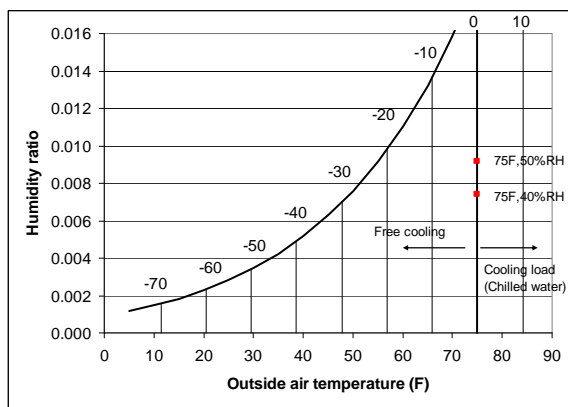

(a) Sensible load (Btu/h-CFM)

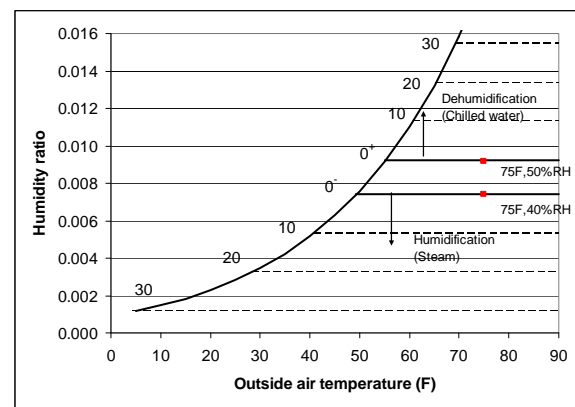

(b) Latent load (Btu/h-CFM)

Fig. 1: Normalized outside air energy consumption

CONFIGURATION AND OPERATION

Air handling units with humidity control in commercial buildings typically include a preheating coil, a chilled water cooling coil, a steam humidifier

and terminal boxes with a reheat coil. Figure 2 shows a schematic of a typical AHU. The AHU also has an economizer cycle with interlinked outside air, return air and relief air dampers.

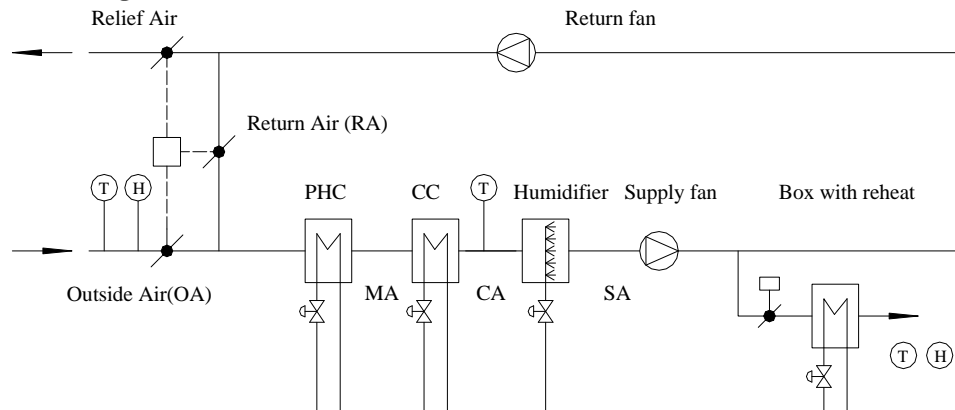

Fig. 2: Schematic of typical AHU

Outside air control

The outside air damper can adjust the outside airflow from a minimum level to 100%. Actually the outside air damper only maintains two selectable outside airflows:

- Minimum outside air flow within the minimum outside air cycle, or
- Economizer outside air flow that seeks mixed air temperature at a supply air temperature set point within the economizer cycle.

Outside airflow can be expressed as an outside air ratio, which is a ratio of outside airflow to total airflow. Minimum outside air ratio (α_{\min}) always maintains a constant minimum value required by building personalization and indoor air quality. Meanwhile, the economizer outside air ratio (α_{eco}) varies with outside air temperature (t_{oa}), room return air temperature (t_{ra}) and supply air temperature set point ($t_{sa,sp}$).

$$\text{When } t_{oa} < t_{ra} - \frac{t_{ra} - t_{sa,sp}}{\alpha_{\min}},$$

$$\alpha_{eco} = \alpha_{\min}. \quad (1)$$

$$\text{When } t_{ra} - \frac{t_{ra} - t_{sa,sp}}{\alpha_{\min}} \leq t_{oa} < t_{sa,sp},$$

$$\alpha_{eco} = 1 - \frac{t_{sa,sp} - t_{oa}}{t_{ra} - t_{oa}}. \quad (2)$$

$$\text{When } t_{oa} \geq t_{sa,sp},$$

$$\alpha_{eco} = 1. \quad (3)$$

The outside airflow ratio will affect mixed air conditions, which are related to the energy consumption of the cooling coil and the humidifier. The mixed air conditions (t_{ma} and w_{ma}) are determined by the outside air conditions (t_{oa} and w_{oa}) and the return air conditions (t_{ra} and w_{ra}), as well as the outside air ratio (α_{\min} or α_{eco}).

$$t_{ma} = \alpha \cdot t_{oa} + (1 - \alpha) \cdot t_{ra} \quad (4)$$

$$w_{ma} = \alpha \cdot w_{oa} + (1 - \alpha) \cdot w_{ra} \quad (5)$$

Preheat coil

When the outside air temperature falls within the outside air condition given in Eq. (1), the minimum outside air requirement causes the mixed air temperature below the supply air temperature set point. Under this condition, the preheat coil has to be enabled to maintain the mixed air temperature at the supply air temperature set point. Since the outside air flow always maintains a minimum level when the humidifier is enabled, the heating energy for the preheating coil is identical between the economizer and minimum outside air cycles. Therefore, the

heating energy for the preheat coil and its corresponding outside air temperature condition can be excluded in total energy optimization.

Cooling coil

The cooling coil is enabled to maintain the cold air temperature at the supply air temperature set point if the mixed air temperature is higher than the supply air temperature set point. Chiller water energy depends on the cooling coil performance.

The cold air temperature is always equal to the supply air temperature set point for normal coil design and operation. However, calculation of the cold air humidity ratio is complicated. When the mixed air is dry, the cooling coil operates at a completely dry condition and the cold air humidity ratio is equal to the mixed air humidity ratio with a zero latent cooling load. On the other hand, when the mixed air is humid, the cooling coil operates at either a completely wet or partially wet condition. As a result, the cooling coil has both cooling and dehumidification functions, and the dehumidification is coupled with the cooling process. In general the cold air humidity ratio (w_{ca}) is determined by the mixed air temperature and humidity ratio (t_{ma} and w_{ma}), the total airflow (\dot{m}_a) and the cold air temperature (t_{ca}) for a cooling coil with known chilled water supply temperature. A simulation model of chilled water cooling coils is applied in the cold air humidity calculation. This simulation model combines the effectiveness-NTU (number of transfer unit) method and the finite element method. A cooling coil is divided into several elements. A sensible heat ratio (SHR) is used to decouple sensible and latent heat transfer and represents the wet or dry condition within each element [Wang et al. 2005]. Generally the cold air temperature and humidity ratio can be expressed as

$$t_{ca} = t_{sa,sp} \quad (6)$$

$$w_{ca} = f(t_{ma}, w_{ma}, \dot{m}_a, t_{ca}) \quad (7)$$

Consequently the normalized chiller water energy can be expressed as:

$$\bar{Q}_c = c_{pa} (t_{ma} - t_{ca}) + h_g (w_{ma} - w_{ca}) \quad (8)$$

Steam humidifier

The supply air temperature setpoint also controls the maximum indoor humidity level. On the other hand, the minimum indoor humidity level has to be maintained by the steam humidifier. The humidifier is enabled if the indoor humidity is lower than minimum indoor humidity set point. If indoor moisture load is neglected, the indoor humidity ratio will be equal to the supply air humidity ratio. When the supply air humidity ratio (w_{sa}) is lower than the

minimum indoor humidity ratio set point (w_{\min}), the humidifier should be used. The normalized steam energy consumption can be expressed as:

$$\bar{Q}_s = h_g \cdot (w_{\min} - w_{sa}) \text{ if } w_{\min} > w_{sa} \quad (9)$$

Terminal box

The air damper and reheat coil valve of a terminal box are modulated to maintain space temperature based on terminal box control sequences. The terminal box operation only depends on the AHU supply air temperature, the box minimum airflow setpoint and the space cooling load. The terminal box operation has nothing to do with the outside air control. Therefore, the reheat coil heating energy of terminal boxes also can be excluded in total energy optimization.

OPTIMIZATION

The AHU total energy consumption includes the energy consumption at the preheat coil, the cooling coil, the humidifier and the reheat coil. However, the outside air flow only affects the chilled water energy consumption at the cooling coil and the steam consumption at the humidifier. Therefore, the energy cost for outside air control optimization only includes the chilled water energy cost and the steam cost.

$$C = \bar{Q}_c \cdot \dot{m}_a \cdot P_c + \bar{Q}_s \cdot \dot{m}_a \cdot P_s \quad (10)$$

Two variables are defined in order to simplify the energy cost expression. The energy price ratio is defined as the ratio of the steam energy price to the chilled water energy price.

$$P_r = \frac{P_s}{P_c} \quad (11)$$

Then the energy price ratio is used to convert the steam energy to the equivalent chilled water energy, which has the same cost as steam energy. The normalized equivalent energy can be defined by Eq. (12) as

$$\bar{Q}_e = \bar{Q}_c + P_r \cdot \bar{Q}_h \quad (12)$$

Consequently the total energy cost is expressed as

$$C = P_c \cdot \dot{m}_a \cdot \bar{Q}_e \quad (13)$$

Since the chilled water energy price and AHU airflow are independent with the outside airflow, the minimized normalized equivalent energy consumption represents the minimized total energy cost. Therefore, the outside air control optimization is to choose either the minimum outside air ratio (α_{\min}) or the economizer outside air ratio (α_{eco}) to minimize the normalized equivalent energy consumption under different outside air conditions (t_{oa} and w_{oa}).

A normalized equivalent energy difference between the economizer and minimum outside air cycles can be expressed as

$$\Delta \bar{Q}_e = \bar{Q}_{e,eco} - \bar{Q}_{e,\min} \quad (14)$$

The normalized equivalent energy difference varies with outside air conditions. An outside air curve on the psychrometric chart with zero energy difference ($\Delta \bar{Q}_e = 0$) represents the optimal high-limit shutoff curve. The outside air zone with negative energy difference ($\Delta \bar{Q}_e < 0$) has less energy cost with the economizer cycle and represents the optimal economizer zone. The outside air zone with positive energy difference ($\Delta \bar{Q}_e > 0$) has less energy cost with the minimum outside air cycle and represents the optimal minimum outside air zone. In general the optimal minimum outside air zone is on the right-hand side of the high-limit shutoff curve while the optimal economizer zone is on the left-hand side of the high-limit shutoff curve.

APPLICATION

Simulations were conducted on a constant air volume AHU with a minimum outside air ratio of 10%, a constant supply air temperature set point of 55°F and a design space dry bulb temperature of 75°F. In order to cover different humidity ranges in commercial buildings, four different minimum indoor relative humidity set points were chosen for the simulations: 0%, 20%, 30% and 40%. Chilled water and steam price primarily depended on chilled water and steam sources. Table 1 lists the chilled water and steam prices as well as the energy price ratios, which were collected from different commercial buildings in Omaha, Nebraska. Four different energy price ratios (0, 1.0, 2.0 and 4.0) were selected for the simulation.

Energy cost comparison between the economizer and minimum outside air cycles

The normalized equivalent energy difference between the economizer and minimum outside air cycles was simulated using Eq. (14) over the psychrometric chart with different energy price ratios and different minimum indoor relative humidity set points. Figure 3(a) shows energy difference contours without humidity control, and Figure 3(b) shows energy difference contours with a 30% minimum indoor relative humidity set point. The actual outside air contour at Omaha, Nebraska is also marked with dash lines in these figures. An energy price ratio of 1.0 is chosen in Figure 3. Obviously, cold (and mild humid) outside air is suitable for the economizer cycle while humid and warm (or dry and warm) outside air is suitable for the minimum outside air cycle. The contour with a zero energy difference represents the optimal high-limit shutoff curve. The shutoff curve, without humidity control in Figure 3(a), perfectly matches the curve of the electronic enthalpy control, described by ASHRAE (2001). However, when the minimum indoor humidity is required, the vertical shutoff curve below the

minimum humidity ratio set point is replaced by the slope line due to steam humidification. Normalized equivalent energy difference contour

charts for all energy price ratios and minimum indoor relative humidity set points are given in the Appendix

Tab. 1: Chilled water and steam price and energy price ratio

Building	Energy type	Unit	Price	\$/1000Btu	Ratio
Purchased from an energy company	Steam	\$/1000lb	20.270	0.020	0.8
	Chilled Water	\$/ton-hr	0.289	0.024	
Electrical humidifier and electrical chiller	Steam	\$/kWh	0.055	0.016	4.0
	Chilled Water	\$/kWh	0.014	0.004	
Natural gas boiler and electrical chiller	Steam	\$/therm	0.650	0.009	2.3
	Chilled Water	\$/kWh	0.014	0.004	

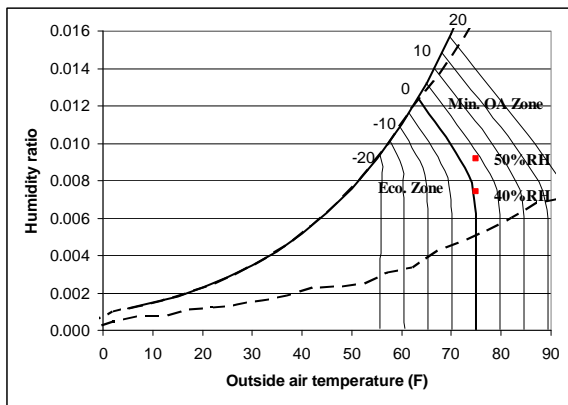

(a) No humidity control

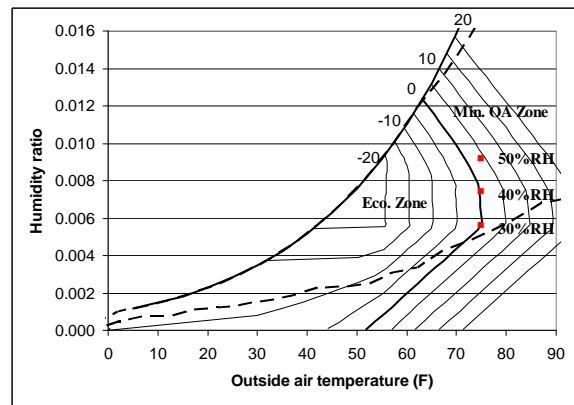

(b) 30% indoor relative humidity

Fig. 3: Normalized equivalent energy difference

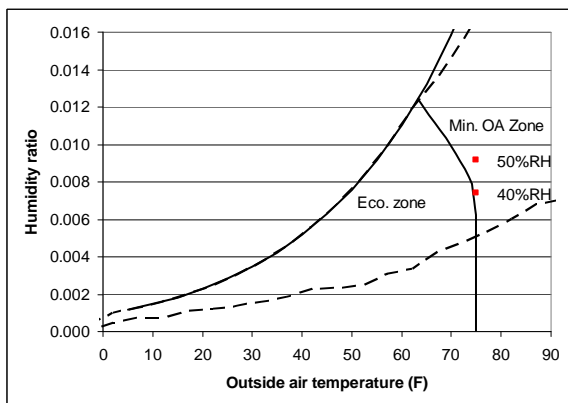

(a) No indoor humidity control

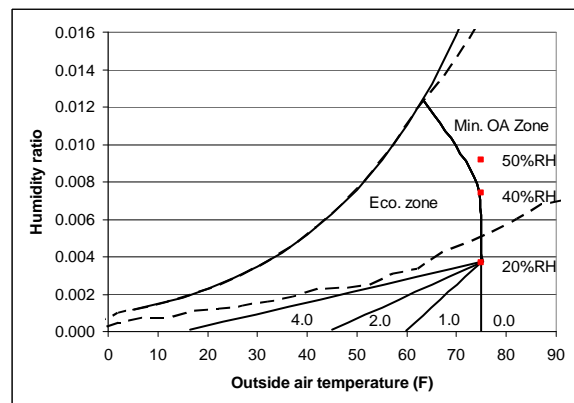

(b) 20% indoor relative humidity

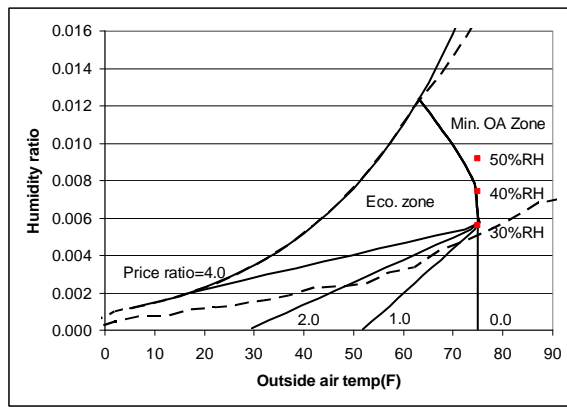

(c) 30% indoor relative humidity

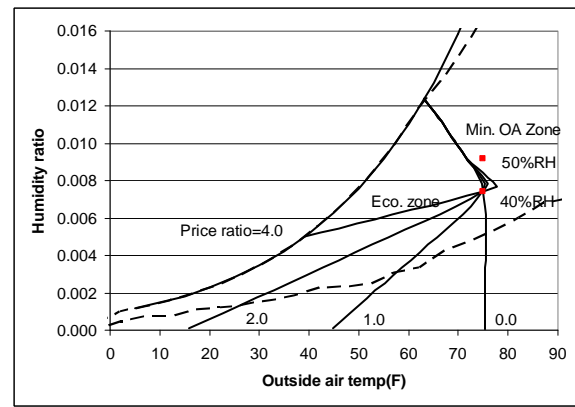

(d) 40% indoor relative humidity

Fig. 4: Optimal high-limit shutoff curves vs. different energy price ratios

Optimal high-limit shutoff curve

Figure 4 presents the optimal high-limit shutoff curves under different conditions. All the optimal high-limit shutoff curves above the minimum indoor humidity ratio set point perfectly match the electronic enthalpy control, which is given by ASHRAE (2001). However, the optimal curve is replaced by a slope line below the minimum indoor humidity ratio set point.

Figure 4 also shows that the slope line goes through the point at the design space temperature and the minimum indoor humidity set point, and the slope of the line is related to the energy price ratio. Actually the slope line can be theoretically deduced. When both the outside and space air have a humidity ratio no more than the humidity ratio at the design space temperature and 40% relative humidity, the cooling coil will operate at a completely dry condition.

When outside air humidity is higher than the minimum indoor humidity set point, the humidifier is disabled. The normalized equivalent energy for the economizer and minimum outside air cycles can be expressed by Eqs. (15) and (16).

$$\bar{Q}_{e,eco} = c_{pa}(t_{ra} - t_{sa}) + c_{pa}\alpha_{eco}(t_{oa} - t_{ra}) \quad (15)$$

$$\bar{Q}_{e,min} = c_{pa}(t_{ra} - t_{sa}) + c_{pa}\alpha_{min}(t_{oa} - t_{ra}) \quad (16)$$

When outside air humidity is lower than the minimum indoor humidity set point, the humidifier has to be used to humidify the outside air to the minimum indoor humidity set point. The normalized equivalent energy for the economizer and minimum outside air cycles can be expressed by Eqs. (17) and (18).

Comparison of annual energy consumption

Three different outside air control methods are applied in an annual energy comparison.

- The conventional control is the fixed temperature control with a high-limit shutoff temperature of 68°F.

- The minimum outside control maintains a constant minimum outside airflow ratio all the time.
- The optimal outside air control uses the optimal high-limit shutoff curve developed in this paper.

The outside air condition uses 4-hour weather bin data at Omaha, Nebraska. The minimum outside airflow ratio is 10% in the comparison. Table 2 summarizes the annual normalized equivalent energy among the conventional control, the minimum outside air and the optimal outside air control. The optimal control has the least energy cost. The conventional control may consume up to 27% more energy cost than the optimal control. The minimum outside air control is suitable only for the system with a high minimum humidity set point (40%) and a high energy price ratio (4.0). However, the minimum outside air control still consumes at least 7% more energy cost than the optimal control.

CONCLUSION

An optimal economizer high-limit shutoff curve is developed on a psychrometric chart under different energy price ratios and minimum indoor humidity set points. The optimal curve has the same curve as the electronic enthalpy curve above the minimum indoor humidity set points and diverges to different slope lines below the minimum indoor humidity set point. These slope lines pass the point at the design room temperature and a minimum humidity ratio set point, and have a slope related to the energy price ratio. The simulation shows that the optimal control can save as much as 27% more energy costs than the conventional control and at least 7% more than the minimum outside air control.

Tab. 2: Comparison of annual normalized equivalent energy consumption

OA control	Indoor	Annual normalized equivalent energy				Percentage based on the optimal control			
	RH	(BTU/CFM-total)				(%)			
	set point	Energy price ratio				Energy price ratio			
	(%)	4	2	1	0	4	2	1	0
Conventional		281,982	180,991	130,495	79,999	127%	103%	101%	102%
Min. OA		238,507	212,123	198,932	185,740	107%	120%	154%	236%
Optimal	40	221,988	176,458	129,141	78,570	100%	100%	100%	100%
Conventional		179,757	129,902	104,974	80,046	105%	101%	101%	102%
Min. OA		208,434	195,999	189,781	183,563	121%	153%	183%	233%
Optimal	30	171,893	128,479	103,628	78,701	100%	100%	100%	100%
Conventional		109,497	94,834	87,502	80,170	101%	101%	102%	102%
Min. OA		193,948	188,846	186,295	183,744	179%	202%	216%	233%
Optimal	20	108,142	93,479	86,147	78,815	100%	100%	100%	100%
Conventional		80,348	80,348	80,348	80,348	102%	102%	102%	102%
Min. OA		183,927	183,927	183,927	183,927	233%	233%	233%	233%
Optimal	0	79,034	79,034	79,034	79,034	100%	100%	100%	100%

NOMENCLATURE

- c_{pa} - air constant pressure specific heat
- C - energy cost
- h_g - latent heat of vaporization
- \dot{m}_a - air flow rate
- P_c - cooling (chilled water) energy price, \$/BTU
- P_r - energy price ratio, ratio of heating (steam) energy price to cooling (chilled water) energy price
- P_s - heating (steam) energy price, \$/BTU
- \bar{Q}_c - normalized chilled water energy consumption, BTU/h-CFM
- \bar{Q}_e - normalized total equivalent energy consumption, BTU/h-CFM
- \bar{Q}_s - normalized steam energy consumption, BTU/h-CFM
- t - air dry bulb temperature, ° F
- w - humidity ratio of moist air
- α - outside air flow ratio, ratio of outside air flow to total supply air flow

$\Delta\bar{Q}_e$ - normalized equivalent energy consumption difference between economizer and minimum outside air cycles

Subscripts:

- ca - cold air
- eco - economizer cycle
- ma - mixed air
- min - minimum outside air cycle or minimum indoor set point
- oa - outside air
- ra - return air
- sa - supply air
- sp - set point

ACKNOWLEDGEMENT

Authors would like to express appreciation for Ms. Derrick's editorial assistance.

REFERENCES

- [1] ASHRAE. 1999. 1999 ASHRAE Applications Handbook. American Society of Heating, Refrigerating and Air-conditioning Engineers, Inc., Atlanta, GA.
- [2] ASHRAE. 2001. Energy Standard for Buildings except Low-Rise Residential Buildings. ANSI/ASHRAE/IESNA 90.1-2001. American Society of Heating, Refrigerating and Air-conditioning Engineers, Inc., Atlanta, GA.

[3] ASHRAE. 2004. Thermal Guidelines for Data Processing Environments. American Society of Heating, Refrigerating and Air-conditioning Engineers, Inc., Atlanta, GA.
 [4] Chu L, J Weale, and P Rumsey. 2006. A Design Guideline Sourcebook: High Performance Data Centers. Energy Design Resources.
 [5] Saman NF and HW Johnstone. 1996. Maintaining Temperature and Humidity in Non-humidity-generating Spaces. ASHRAE Transactions 102(2):73-79.
 [6] Wang G, M Liu and D Claridge. 2005. Decoupled Modeling of Chilled Water Cooling Coils Using Finite

Element Method, International conference for enhanced building operations, Pittsburgh.

APPENDIX: NORMALIZED EQUIVALENT ENERGY CONSUMPTION DIFFERENCE

Figure A1 shows the normalized equivalent energy consumption difference (Btu/h-CFM) between the economizer and minimum outside air cycle in the psychrometric chart under different conditions. The energy price ratios are 0, 1.0, 2.0 and 4.0 while the minimum space relative humidity set points are 0%, 20%, 30% and 40%.

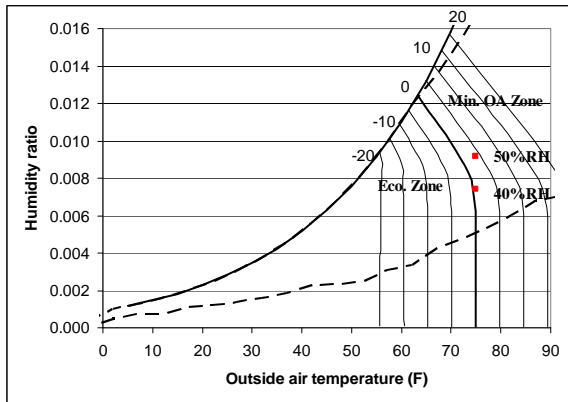

(1) Free steam or no humidity control

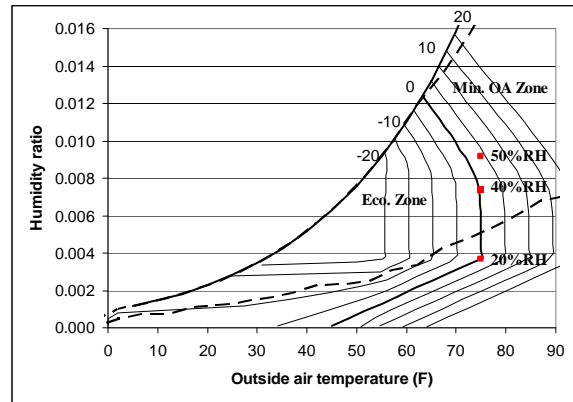

(3) Energy price ratio of 2.0 and 20% humidity

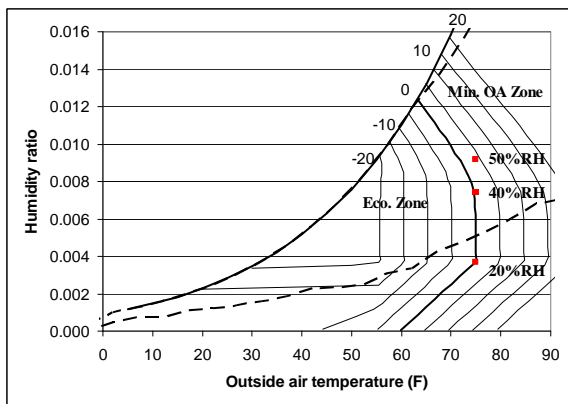

(2) Energy price ratio of 1.0 and 20% humidity

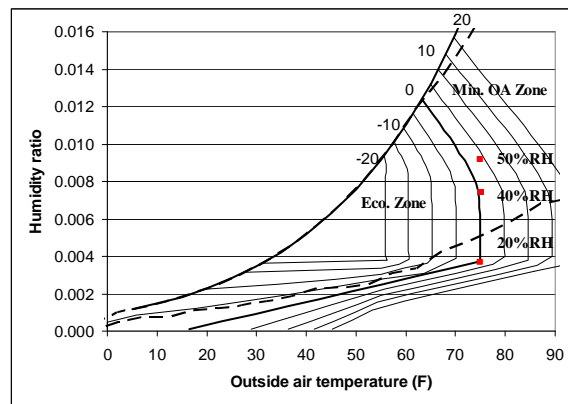

(4) Energy price ratio of 4.0 and 20% humidity

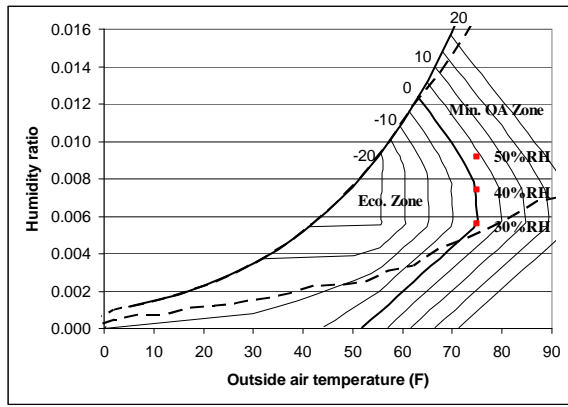

(5) Energy price ratio of 1.0 and 30% humidity

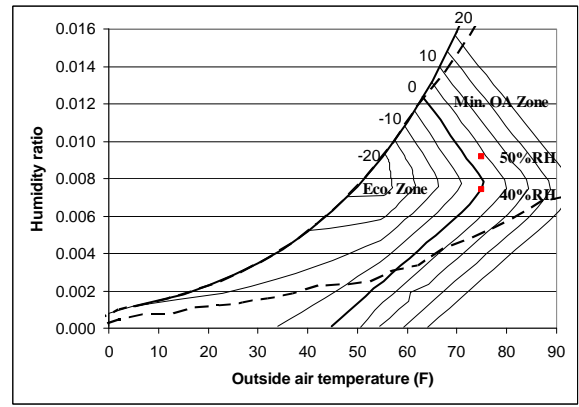

(8) Energy price ratio of 1.0 and 40% humidity

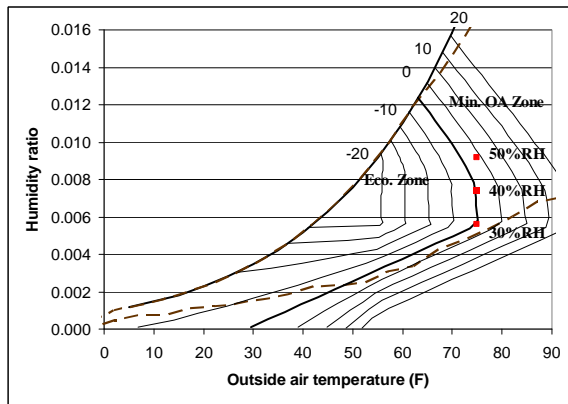

(6) Energy price ratio of 2.0 and 30% humidity

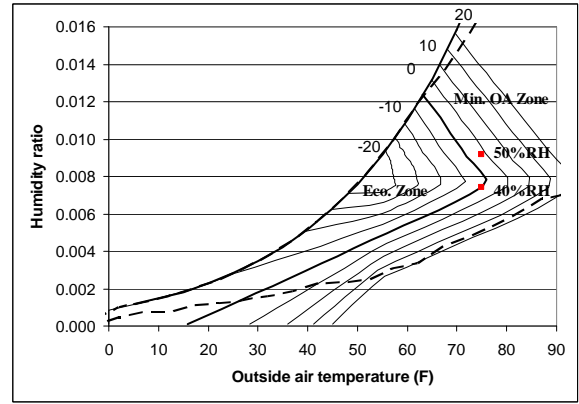

(9) Energy price ratio of 2.0 and 40% humidity

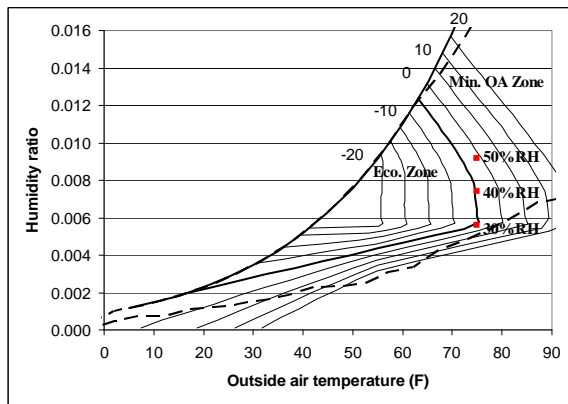

(7) Energy price ratio of 4.0 and 30% humidity

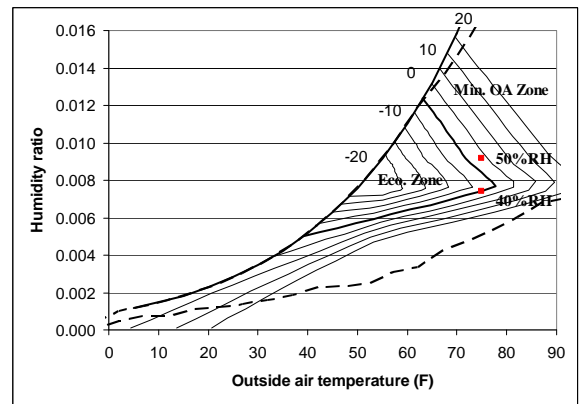

(10) Energy price ratio of 4.0 and 40% humidity

Fig. A1: Normalized equivalent energy consumption difference contours