

Commissioning to Meet Space Qualification Criteria vs. Energy Consumption Optimization Focused Commissioning

*By: David Sellers, Senior Engineer, Portland Energy Conservation Inc, Portland, Oregon
Linda Irvine, Program Assistant, Portland Energy Conservation Inc., Portland, Oregon*

ABSTRACT

In many cases, the commissioning process is driven by space quality criteria rather than by energy consumption and optimization criteria. This is especially true for the HVAC systems serving clean rooms in the semi-conductor and pharmaceuticals industry. Experience has shown that commissioning targeted at meeting space qualification requirements alone may not necessarily result in an energy efficient delivery system. On the other hand, commissioning that is focused on meeting the space qualification requirements in as efficient a manner as possible will result in success in both areas. This paper will focus on a case study of a make-up air handling system where space-quality-focused commissioning resulted in some very significant energy consumption problems.

INTRODUCTION

At a new wafer fab, the newly hired HVAC and fire protection facilities engineer spent most of the first month on the job learning about the specifics of the production process and playing catch-up with the new construction project. About one third of the facility was operational, doing qualification runs to prove that the fab could manufacture a quality product. The other two thirds was just coming out of the ground

Finally, one July day, the new engineer spent some time exploring the operating portion of the plant, to learn where systems were and get a feel for the general operating status of the HVAC equipment when it was serving an on-line process. To his surprise, when he walked into the service corridor for the 45,000 cfm EPI clean room make up air handling unit, he heard sounds typically associated with high steam flow rates in piping systems. Given that this was a process environment and the system was serving a clean room with specific temperature and humidity operating requirements, he surmised that the steam flow was associated with a reheat burden required to keep the temperature and relative humidity parameters in spec. On closer inspection, however, he noticed that the trap from the preheat coil was quite hot. In the course of the next 30 minutes, he found:

- The preheat coil was active and heating the 81°F outdoor air to 115°F.
- The cooling coil was cooling this air to 40°F.
- The reheat coil was heating this air back up to 46°F.

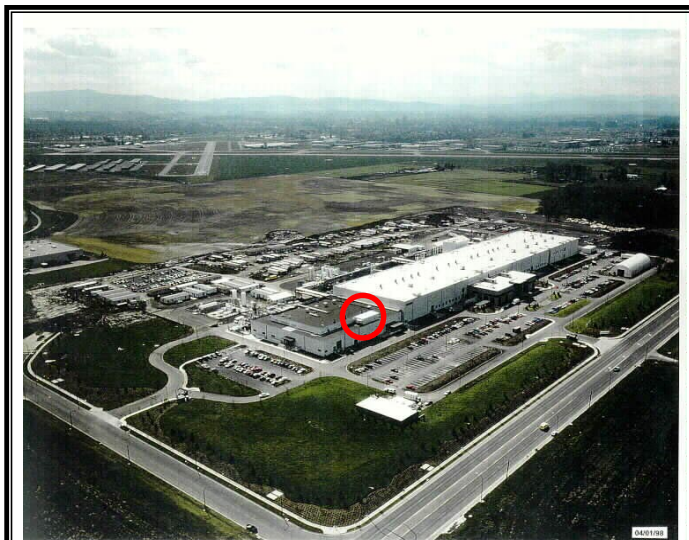

Figure 1 – A Modern Semi-conductor Wafer Plant

To get an idea of scale, the main building is about one quarter mile long. The system that is the subject of the paper serves a clean room at the left end (the area with the dark roof). The air handling unit is circled.

- The humidifier was active and injecting a considerable amount of moisture into the air.
- The fan heat was raising the temperature of the air to 54°F.
- The clean room conditions were right on specification.

This information was gathered using fairly simple techniques including:

- *Visual and sensory observation* – Moisture was visibly being injected by the humidifier and high steam and chilled water flow rates were audible. The traps and piping systems were hot to the touch.
- *Local indicators* – Visual observations were confirmed and refined using local thermometers and a local display on the Direct Digital Control System (DDC System) controller serving the unit.
- *Radio and phone discussions* – Clean room operating status and central plant status were confirmed by phone and radio calls to managers and operators.

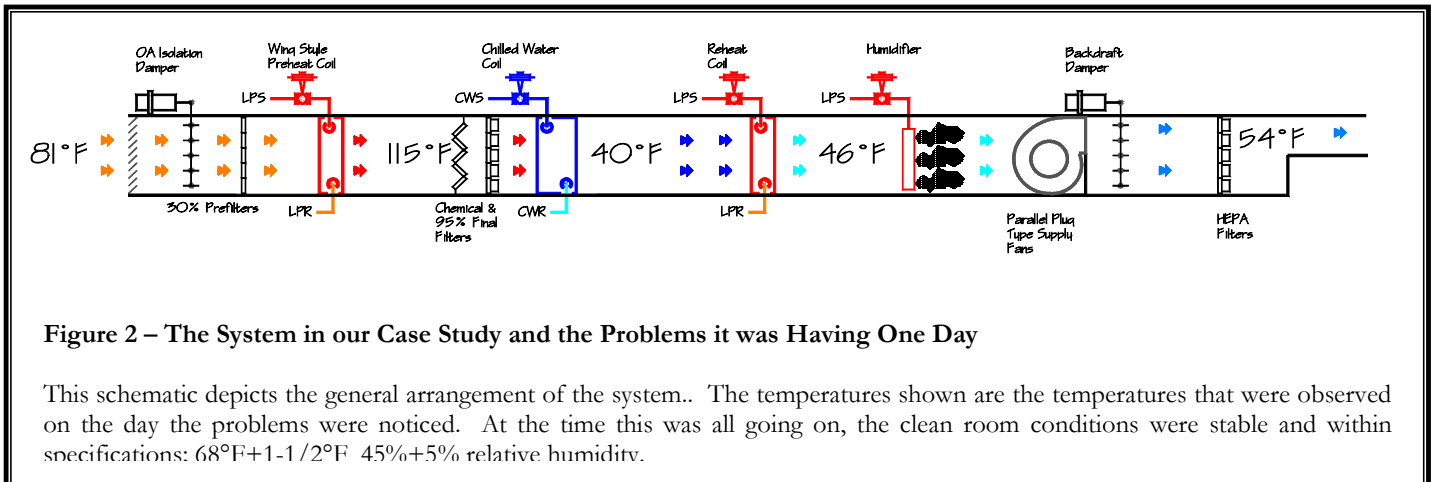

Figure 2 – The System in our Case Study and the Problems it was Having One Day

This schematic depicts the general arrangement of the system.. The temperatures shown are the temperatures that were observed on the day the problems were noticed. At the time this was all going on, the clean room conditions were stable and within specifications: 68°F+1-1/2°F 45%+5% relative humidity.

- *Hand held, portable temperature probes* – Temperatures were cross-checked against a common denominator using a portable electronic temperature sensor

In other words, none of the symptoms were particularly hidden or difficult to detect.

Figure 2 illustrates these observations on a schematic of the system. Figure 3 compares the observed process with the process needed to satisfy the space temperature and humidity requirements on a psych chart. As evident, the process was consuming much more energy than required to meet the desired space condition. Some key points to notice on the psychrometric chart are:

- Satisfying the space temperature and humidity requirements in a dehumidification mode would require a coil discharge condition of approximately 46°F_{tdb}/45.5°F_{twb}. In theory, this could be achieved by simply cooling the outdoor air to a 46°F discharge temperature on a sufficiently deep cooling coil.
- There is no psychrometric justification for operating the preheat coil when the outdoor temperature is above the discharge temperature required to meet the space sensible cooling requirements.
- In the “as found” operating mode, the chilled water coil was cooling the air approximately 6°F below the discharge temperature necessary to satisfy the space relative humidity requirement. As a result, the system had to humidify and reheat to hold the necessary space condition. The humidifier was putting water back into the air stream although water had been removed and was probably still in the drain pan approximately 15 feet upstream. The energy impact of this was compounded by the fact that the humidity was generated by using steam to boil Reverse Osmosis DeIonized water (RODI) rather than by direct steam injection. This approach was taken to minimize the potential for contamination

via trace chemicals from the water treatment associated with the steam system. All of the water boiled off to humidify was generated by the site’s RODI plant, which was an energy intensive process all by itself.

A rough, bin type energy calculation indicated that the system was using between \$5,000 and \$7,000 more energy per month than it needed in the current operating mode. Most of the extra energy was in the form of steam consumed in the preheat coil, humidifier, and reheat coil. However, there were also some electrical penalties associated with providing unnecessary cooling from the electrically driven chiller plant and providing RODI water for humidification from the RODI plant.

WHY WAS THIS HAPPENING?

As the engineer tried to understand why the system was operating this way, he discovered answers that fell into the following general categories.

- From a process standpoint, the clean room managers and operators were happy if the clean room environment was within specifications (68°F+1-1/2°F, 45%+5% relative humidity) and stable; i.e. any changes that occurred within the tolerance band occurred at a very slow rate.

The plant was essentially a design-build, fast track project, with performance based on a set of “Owner’s Requirements” (ORs). The ORs were very specific about the conditions needed in the clean rooms, but didn’t specify how to achieve them, although the general configurations of the HVAC systems were specified.

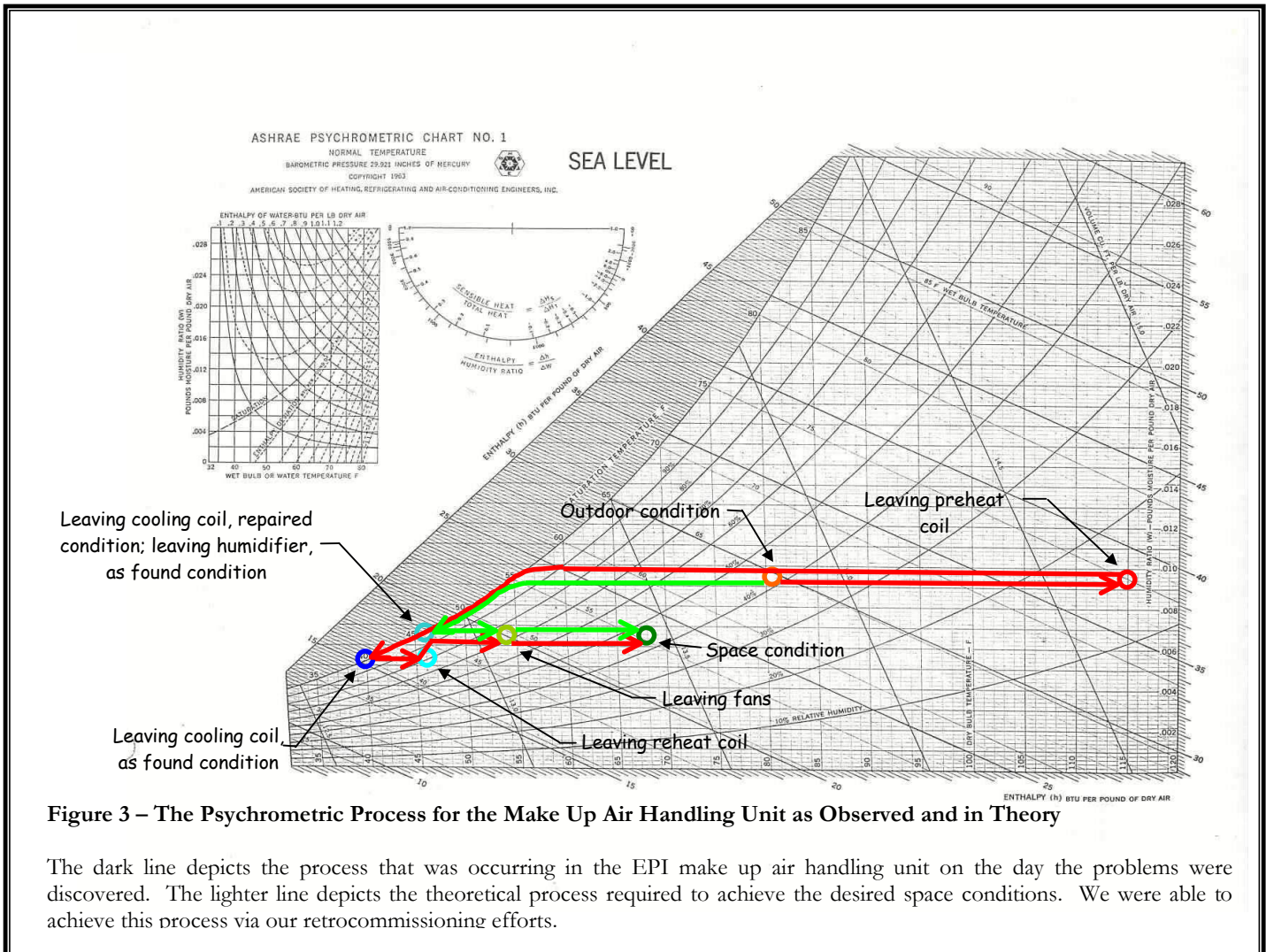

- The ORs also included the requirement for system commissioning. However, they focused on clean room qualification requirements and didn't detail how the support systems were to be started up and commissioned. As a result, the commissioning process consisted of a very thorough prestart and start-up process in which all the individual components of the HVAC equipment were inspected, tested, and verified. However, there was no HVAC system-focused functional testing process that verified the interaction of all of the system components. The only real functional testing that occurred was in response to the clean room certification process, which was focussed on clean room parameters, not on HVAC system parameters.
- The silicon wafer industry business cycle is more like a square wave than a sine wave or any other gradual transition from peak to valley. When construction was initiated, there was very intense pressure to build the plant, bring it on line and get it into production

in the shortest time possible. As a result, contractors were often told to "do what ever it takes to get that system on line so we can start production."

In the case of this particular system, the contractor had been told to do what ever it took to get the clean room qualified as quickly as possible. The qualification process involves a very extensive testing and documentation protocol under which all aspects of the clean room environment are measured in great detail. Systems were adjusted until the clean room maintains specifications for particle counts, pressure relationships, lighting levels, sound levels, vibration levels, temperatures, and humidity in a consistent and stable manner in all operating modes. While the engineer was never able to learn the exact logic that led to the observed system operating mode, it appeared to be the result of well intentioned people doing all of the wrong things for all of the right reasons and all of the right things for all of the wrong reasons. For instance,

if the testing firm performing the clean room qualification indicated that humidity levels were above spec, the control systems contractor might have lowered the cooling coil discharge temperature by some arbitrary amount to “wring more water out of the air”. Without guidance or specific knowledge of the psychrometrics of the system, they were inclined to err on the “safe side”; i.e. lower it a lot rather than a little. A couple of days later, the qualification testing firm might report that the room was now running below limits. The control contractor would respond by sending a technician out to adjust the system. (Many times, this was not the person who made the previous adjustment.) The technician would usually take the most direct step available to solve the immediate problem; in this case, it would be raising the discharge humidity controller set point. As a result, the system became locked in an operating mode where it over-cooled and over-dehumidified at the cooling coil, then made up for the deficiency by humidifying and reheating.

Compounding this problem was the fact that the plant was in a start-up mode, the operators and facilities engineers were just being hired and nobody had been trained on the operation of the control system. Most of the operators didn't have passwords that let them into the system far enough to operate effectively. System documentation was poor and it used the same name for all points of a particular type. For instance, when the alarm printer typed out “HI TEMP ALARM – SPACE TEMP” an operator knew that at least one of approximately 253 space temperature points was out of range. As a result, the operators were frustrated with the control system and had given up on it for the time being. As long as the conditions in the clean room were within spec, they focussed their efforts on simply keeping the plant running - no easy task with the plant in a daily state of flux as systems were added and expanded to accommodate the new construction.

SOLVING THE PROBLEM

It wasn't difficult to convince the facilities group that they should look at other ways of operating the EPI make up air handling system. For one thing, design changes in the second phase of construction had generated some concerns about whether the capacity available in the central plant would be able to meet the expanded loads. Reducing the on-going EPI energy consumption would make additional capacity available for other areas. In addition, \$5,000 to \$7,000 per month of utility consumption represents a lot of money, even in an energy-intensive process like semiconductor manufacturing. An additional concern was that the three new make up air handling systems that were to be installed in the plant expansion were currently specified to be exact replications of the EPI

system from a control standpoint. If the facilities group couldn't identify and prove less energy-intensive approaches to controlling the EPI make up air handling unit, then in about a year, they would have four systems operating in this highly inefficient manner.

A team composed of the plant operators, electricians, the plant process control engineer, and the plant HVAC engineer was assembled to tackle the problem. The biggest challenge in modifying the unit's operation was ensuring that any modifications would not affect clean room conditions enough to ruin product, upset process instrumentation, or otherwise impact product quality or quality control standards. Often, this means that performing such work is relegated to weekends and scheduled production shut downs. However, in this case, cooperative production managers worked to provide windows in the production schedule where modifications with potential to upset the system could be made without risking damage to product. As a result, the team was able to solve the problem one issue at a time over the course of a couple of months, rather than waiting six months to a year for a scheduled outage. The following paragraphs discuss how they accomplished this.

ELIMINATING UNNECESSARY PREHEAT

The first efforts focused on eliminating the unnecessary operation of the preheat coil during the summer months. This problem had several components.

- The preheat coil was an integral face and bypass coil. These coils differ from a conventional face and bypass coil in that the heating elements are arranged vertically and enclosed by vertical dampers. These dampers can modulate so that air is either directed over the heating element or around the heating element. The arrangement has the advantage of being less prone to freezing since temperature control is achieved by mixing warm and cold air rather than by modulating fluid flow in the heating element. Thus, the heating element is always active, and the vertical element orientation assures rapid condensate drainage from the portions exposed to subfreezing air. The disadvantage is that the active heating element will radiate heat to the dampers and thereby heat the air, even if all air flow is directed around it; i.e. the full bypass mode. It is not unusual to pick up a 4 or 5°F rise across one of these coils in the full bypass position. For this reason, the coil's steam supply line is typically equipped with a shut-off valve to allow the heat source to the heating elements to be turned off when it is not needed. In this particular case, the valve had been installed but there was no signal connected to the valve, nor was an output to control it programmed into the system. This was fairly easy to solve since there were spare outputs available and the operators and electricians

were capable of running the necessary pneumatic lines. The team initiated a “fill-in time project” to add the necessary hardware and tubing to control the valve. Once the valve is connected to the control system, they will simply program it to open when the outdoor temperatures fall below the current discharge temperature requirement and close when they rise above it, thus activating the preheat coil only when there is a real need. Until such time as the necessary lines are run and the program is activated, the operators are manually valving out the preheat coil when preheat is not required based on ambient conditions.

- The preheat problem was compounded by the fact that the temperature sensor that served as an input to the controller was nearly 10°F off of calibration. As a result, the controller thought it was 10°F cooler at its sensor than it actually was. This problem was due to the failure of the sensor and the team replaced it with a new one of better quality.
- Another compounding factor was that the preheat coil was controlled by an independent control loop based on preheat discharge temperature rather than in sequence with the other HVAC elements controlling the discharge temperature for the system. Changing the set point of the fan discharge temperature controller only impacted the operation of the reheat coil. To completely coordinate such a change, one also had to change the set point of the chilled water coil controller which controlled the cooling coil discharge temperature as well as the preheat coil controller, which controlled for a preheat coil leaving air temperature. The team discovered that at one point, the preheat coil controller had been set for 110°F, probably during the previous winter when the system was in start-up. This setting had never been coordinated with any of the other control settings on the unit. In addition, the control algorithm was written in a manner that caused different operating sequences to be triggered by a change in outdoor conditions. As a result, the entire system operating mode would be switched when the outdoor conditions crossed one of the programmed thresholds. This caused several problems including:
 - Instability due to the step change that was introduced into the system at that time.
 - Inconsistent unit operating modes that were difficult for the operators to detect, understand, and predict.
 - A system operating sequence that was more directly driven by the outdoor conditions than the requirements of the clean room.

The team solved these problems in conjunction with several others by revising the system program so that the preheat face and bypass dampers and the chilled water valve were controlled in sequence as required

to maintain the system’s leaving air temperature. The system could not open the chilled water valve until the preheat face and bypass dampers had been sequenced to full bypass and visa versa. Thus, the unit operated to deliver a consistent, stable leaving condition, which resulted in a stable clean room. Sequencing the various valves and dampers based on the discharge temperature allowed the system to respond to deviations in this parameter rather than trying to change the discharge requirement based on variations in the outdoor condition. Of course, these deviations were the result of variations in the outdoor conditions. This seems like a subtle difference, but it is much more consistent with the HVAC theory behind the clean room make-up air process; i.e. the discharge requirement from the make up system is directly set by the design sensible and latent loads in the space, not the outdoor conditions. In addition to the sequencing modifications, the team programmed the system to force the face and bypass dampers to full bypass any time the outdoor temperature was above the current discharge temperature set point. In theory, this was not necessary since the sequencing of the dampers would prevent simultaneous heating and cooling. But, it was found that the system would stabilize more quickly after an upset during the swing seasons if the ability to use preheat was simply prevented when it wasn’t needed. The team also retained the preheat coil control loop and set it for 40°F. The output of this loop went through a software version of a low signal selector and took over control of the valve if the preheat temperature reached its set point regardless of what the discharge controller was asking for. This step made cold weather restarts easier by eliminating the thermal and transportation time lags associated with the distance between the outdoor air intake and the discharge sensor. It also provided a low limit back-up to the discharge control loop in the event of a problem there.

- No alarms had been installed for the preheat leaving air temperature sensor. In this case, there was no hi or lo alarm for the preheat coil leaving air temperature. Thus, no alarm was generated even though the preheat coil leaving air temperature was nowhere near where it should have been. The graphic for the unit did show the information, but there were two problems with the graphic. It often took several minutes to write to the screen due to a communications problem on the network. The operators seldom used it because they were frustrated with this long delay. In addition, the font was very difficult to read, mostly due to its size. It was quite easy to misread a number. The first step in solving this problem was to simply add alarms to the system so that the operators would be notified if the temperature leaving the coil went out of limits. In

addition, one of the site electricians began working on better graphics for the system as fill-in work between other projects.

ELIMINATING UNNECESSARY COOLING

The problem with the cooling coil discharge temperature was two fold:

- The most fundamental problem was that the sensor was off calibration by 4°F. Since the sensor was an averaging sensor, calibration was tricky. The team used a multi-channel data logger and several factory matched platinum RTD probes to perform the calibration. They simply tie-wrapped the probes to the averaging sensor element at equally spaced intervals. They then calibrated the sensor using the zero and span adjustments so that it reflected the average temperature seen by the individual probes. They performed this procedure at two different temperatures, establishing stable conditions by manually commanding the chilled water valve and preheat valves respectively to a fixed position and allowing things to stabilize. While this was less than an ideal NBS traceable procedure, it was much better than being 4°F off. They had to plan this calibration since it could upset the clean room conditions slightly. However, once they had developed the procedure, it didn't take more than an hour or two including set up time. The actual time spent at either of the extreme temperatures was around 15 minutes and through close monitoring of the clean room, they could actually perform the procedure without getting the clean room out of specs. The team didn't actually calibrate the sensor with the clean room on line, because there was always the possibility of something going wrong. But they did find that they could coordinate with the clean room managers and sneak it in between production runs rather than having to do it over the weekend or during a scheduled outage.
- The other factor contributing to the over cooling problem was that the cooling coil controller was independent of the other controllers rather than sequenced. The 40°F air being delivered by the unit was actually being delivered by a reasonably well tuned PI loop that thought it was making 44°F air. The 44°F set point, combined with the 4°F calibration error resulted in the system supplying 40°F air when 46°F air was all that was necessary in the worst of cases. This problem was solved by sequencing the preheat coil with the chilled water coil. The team also added alarms based on the coil's leaving air temperature and simply forced the chilled water valve closed any time outdoor conditions were such that chilled water cooling was not necessary.

ELIMINATING UNNECESSARY HUMIDIFICATION

The solutions discussed in the preceding paragraphs for eliminating the unnecessary cooling also eliminated most of the unnecessary summer time humidification since the air was no longer over-dehumidified. This improvement was supplemented by making minor modifications to the humidity control loop to improve its alarm and input capabilities. Space humidity sensor calibration techniques were also improved and the calibration schedule for critical sensors was modified to assure that the information provided to the control system was accurate.

ELIMINATING UNNECESSARY REHEAT

The solutions discussed in the preceding paragraphs for eliminating the unnecessary cooling also eliminated the unnecessary reheat load on the system. By coincidence, the fan heat was nearly identical to the reheat requirement. Once the over-cooling problem was eliminated, the reheat coil seldom operated. Figure 4 shows a schematic of the system as it operated after these retrocommissioning efforts.

COSTS OF CORRECTION

Since the correction of the observed problems took place as a part of the on-going operation of the plant, there are no detailed records of the actual costs to correct the problem. However, the following is a reasonable statement of the effort and resources expended in solving the problem.

- *Initial Observation and Documentation of the Problem* – As indicated, the problems were detected in the course of a 30 minute walk-through of the mechanical space. It took another 20 to 30 minutes to formally document the information in the form of field notes, discussions and electronic correspondence.
- *Calculation of the Energy Consumption Burden Represented by the Problems* – The energy cost calculation was performed using a spreadsheet in approximately 4 hours. The spreadsheet had been developed previously as an energy consumption estimating tool and simply used bin weather data and observed system operating parameters to estimate the energy consumed by the system for each weather bin.
- *Modification and Debugging of the System Control Program, Sensor Replacement and Calibration, and Steam Valve Control Output Installation* – The cost for this work was primarily in the form of labor. Material costs were relatively low, probably less than \$500 since some of the hardware required to run tubing and add a control output was kept as stock by the operations and maintenance staff. In total, the labor portion of the work amounted to 9 to 12 man days and involved a team that consisted of

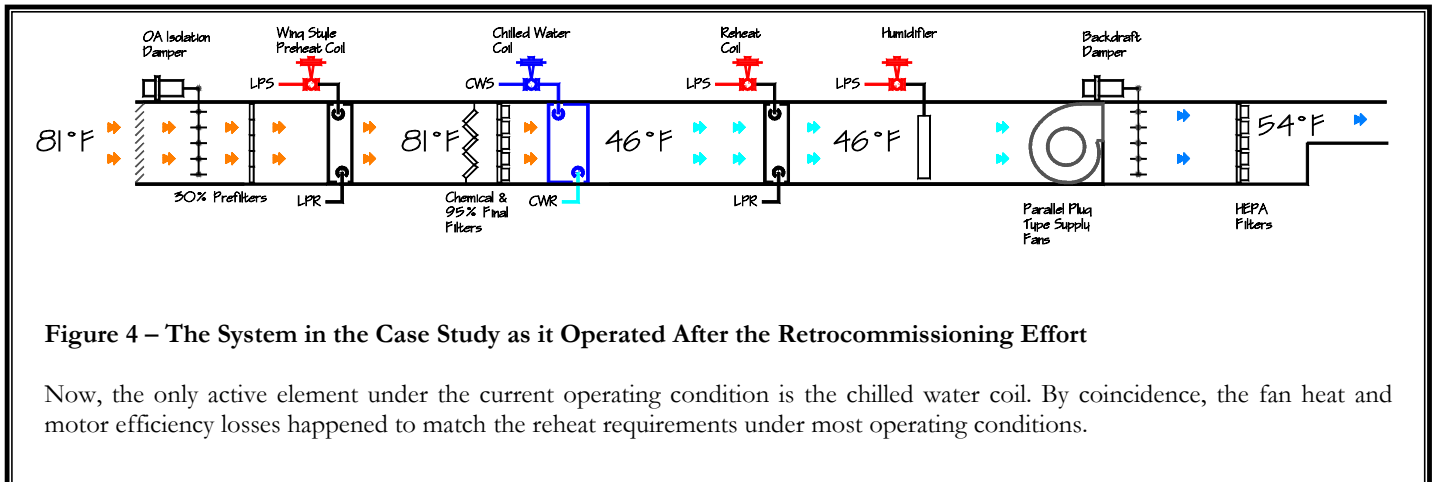

Figure 4 – The System in the Case Study as it Operated After the Retrocommissioning Effort

Now, the only active element under the current operating condition is the chilled water coil. By coincidence, the fan heat and motor efficiency losses happened to match the reheat requirements under most operating conditions.

the plant HVAC Engineer, the plant Process Control Engineer, and all of the plant operators and electricians.

Using a figure of \$55 to \$75 per hour as representative of the costs to the company for an hour of operator or facility engineer time, then the cost of the work is in the range of \$4,700 to \$8,000. As stated previously, this one-time expenditure eliminated an estimated \$5,000 to \$7,000 per month in operating costs during the cooling season. Since the problem was discovered and corrections initiated during the summer months, no effort was made to identify the savings that would have been achieved during the heating season. However, there is reason to believe that monthly winter time savings would have been of the same order of magnitude if not greater since the excessive preheat would have resulted in the system using chilled water for cooling during a period when it should have required no chilled water due to the low outdoor air temperatures. An additional benefit realized from this process was that the control sequences for the three make-up air handling systems that were under construction in the new section of the plant were modified to reflect the lessons learned in the EPI unit.

EDUCATING FACILITY OPERATORS

One of the more significant insights gained from this experience was that what seemed like obvious, easily recognized discrepancies to a trained engineer (e.g. hot traps on a preheat coil during the summer months or an active humidifier downstream of a wet cooling coil) had gone un-noticed for days or even weeks by the facility operators. This was not due to a lack of diligence on the part of the operators. It was simply because nobody had ever taken the time to explain general psychrometrics and/or the specific psychrometrics of this particular clean room process. After recognizing this, a series of informal training sessions were implemented, in which psychrometric theory and its application to the clean room HVAC

process were discussed in layman's terms, including the basics of using a psychrometric chart. Several immediate benefits resulted from this effort.

- The operators started keeping a copy of a psych chart at the operator's console in the control room and would refer to it to try to relate the outdoor and system operating conditions they were observing to the requirements of the clean room.
- Based on their observations, they began to question and evaluate system operation at a much higher level. Instead of getting radio calls saying "something doesn't look right here, so you better come look at it," the facilities engineer started getting radio calls like "I noticed the cooling coil on the PW make up unit was condensing, but (at the current outdoor conditions) I don't think it should have to do that to meet the clean room requirements. Is that right?"
- The operators began to act on their observations rather than waiting until they could get a facility engineer involved in the problem. As a result, many problems were detected and corrected much sooner than they would have been if the solution depended on the involvement of a facilities engineer.

OTHER COMMISSIONING RELATED ISSUES

Thus far, this paper has focused on problems with the control system associated with this unit that were causing it to use excessive amounts of energy to achieve the desired psychrometric results. However, the system also had some other commissioning related problems which may be of interest.

When the system was designed, the designers took the OR requirement for 24 hour per day operation quite literally. This caused several problems including the following.

- No provisions for a coordinated shut down or restart upon recovery from a power failure, fire alarm, or component failure related shut down. Since there were no interlocks to the related exhaust systems, local power failures or equipment failures that shut down the make up unit resulted in floor tiles being sucked out of the raised floor grid in some areas due to the high exhaust flow rates without corresponding make up flow. Failure of the exhaust fans without a make up unit shut down blew out the ceiling tiles in these areas. Both of these problems contaminated the fab and caused serious safety issues since the area where this occurred contained etching baths with very strong acids and bases.
- The supply fans in the unit were powered from the emergency power system (the system had two parallel fans for redundancy purposes). The control system was powered from a Uninterruptible Power Supply (UPS). The interlock circuit that opened the outdoor air dampers when the unit started was on normal power. This lack of coordination, along with some interlock design problems and installation problems, set the system up for a major failure one day when the plant experienced a brief power outage. When the outage occurred, the control system was totally unaware of it since it was on a UPS and had no input to tell it that there was a power failure and no power failure shutdown and recovery software sequence. Since normal power had gone away, the outdoor air dampers closed. And, since the limit switches were very low grade and were set up to prove as soon as the dampers cracked open, and since the limit switches were not wired into a permissive interlock circuit, the fans were allowed to start after about 10 seconds when the emergency generators came on line. Since the fans could generate nearly 8 inches of static at the peak on their curve, and since the closed outdoor air dampers forced them up their curve, the fans started to pull the inlet plenum pressure down toward a negative 8-inch value. But, since the damper assembly was only rated for 4 inches of negative pressure, and since it had not been properly reinforced, the outdoor air dampers collapsed inward, probably when the plenum reached 2 or 3 inches of negative pressure.
- The inrush of air that occurred when the outdoor air dampers collapsed generated an air hammer effect, which uncovered yet another commissioning issue. It turned out that when the unit was reassembled on site, the flange that connected the discharge plenum to the fan section had not been properly bolted up. Instead of

punching a hole in the field-installed gasket material on the flanges and installing the factory provided bolts, washers and nuts in the factory-drilled and aligned holes in the mating flanges, the installers ran self tapping screws through the hole in one flange through the gasket material, and into the hole in the other flange. This meant that there was nothing holding the discharge section to the fan section other than some minor engagement of the perimeter of the zip screw threads with the bolt holes and gravity. This became fairly obvious when the air hammer effect blew the sections apart.

- The system had originally been designed to operate at a nominal 27,000-cfm flow rate on one fan. The second fan was there for 100% redundancy and to allow for future make up if the exhaust flow rates from the fab increased. Unfortunately, the fab envelope construction was very leaky, and rather than find and fix the leaks when the qualification process revealed that the required pressurization could not be achieved, the contractors simply started and ran the second fan until the system moved enough air to pressurize the fab. This took 14,000 more cfm than was designed and required the system to operate at over 7 inches of static rather than the 3.5 inches for which the system was designed. In addition to representing a serious energy burden, operating at this point meant that the supply duct systems were running at pressures above their pressure class rating and could very easily be damaged by any sudden air flow changes in the system (fire damper or smoke damper closure, etc.)

All of these issues could have been addressed by a design phase commissioning process supplemented by a more traditional and rigorous construction phase commissioning process.

INDUSTRY WIDE IMPACT POTENTIAL

Based on other experiences at the site, as well as limited experiences on other sites and discussions with other facilities engineers in the semiconductor industry, it would seem that the experience with the EPI make up air handling unit was the rule rather than the exception. There would seem to be significant opportunities to improve system efficiency and performance for HVAC equipment serving semiconductor clean rooms. Typically, electricity represents 30% to 40% of the net operating costs for these facilities. Gas can represent another 1% to 5% of the operating costs.¹ Annual operating costs can easily run \$4.00 to \$8.00 per square foot of production area due to the energy intensive nature of the processes as well as the round the clock operational requirements. Even in an idle state, a fab will consume significant amounts of energy just trying to maintain cleanliness standards, perhaps 25% to 50%

of what it consumes at production levels. Significant opportunities exist in the operational arena, where existing system and conventional system performance could be improved and optimized beyond the current norm by a more thorough, efficiency-focused commissioning or retrocommissioning process. Even greater opportunities exist by extending the commissioning process to the design phase of the project to allow the commissioning agent to work with the design team to provide systems that deliver the necessary clean room conditions with the least amount of energy. Work by the Northwest Power Planning Council¹ and Lee Eng Lock of SuperSymmetry Services Pte.Ltd.² indicate that a reduction in HVAC energy consumption of 70% or more as well as first costs savings may be possible by taking advantage of opportunities to integrate efficiency with design.

The potential impacts of efficiency-focused commissioning go beyond the more obvious dollars and energy resources that are conserved. The emissions associated with releasing the power and thermal energy stored in fossil fuels can be quite significant. For instance, natural gas releases 120 pounds of CO₂ for every 1000 cubic feet burned. The generation of electricity can release from 1.186 to 2.215 pounds of CO₂ for every kWh generated depending on the area and the mix of generating facilities serving it (coal fired, gas fired, hydro, etc.).³ The “green-house” effect and the global warming implications associated with releasing CO₂ to the atmosphere via these processes is becoming an increasing concern.

APPARENT BARRIERS

Given the magnitude of the savings potential, it is surprising that there does not seem to be a wider acceptance of commissioning, retrocommissioning, design phase commissioning and integrated efficiency design in the semiconductor industry. However, there seem to be several barriers that interfere with taking these steps toward improving system efficiency.

- The semiconductor market is extremely cyclical. In addition, changes in technology can result in the need to retool the production and process equipment every two to four years. Sometimes, things change so quickly that a tool set becomes obsolete between the time that it is conceived and the time that it is placed in operation. In at least one instance, a tool costing hundreds of thousands of dollars was torn out before it had produced any product because it had become obsolete in the time frame of its development cycle⁴. These factors cause the industry to operate on very fast construction schedules, dominated by the need to get a process on line and into production as quickly as possible. The savings that could be achieved by improving efficiency or

considering different design options, though quite significant, are difficult to sell to financial people focused on trying to generate a return on their investment before the market changes or falls away. In at least one instance, a new \$500 million wafer plant was idled before it ever got into production because the market it served went from boom to collapse during the two year construction cycle⁵.

- These quick changes in technology and market strength also cause the financial people behind the plants to require fast paybacks for any proposed conservation measure. This might be justified, if the equipment or system that is being modified may be obsolete and removed from service in one or two years. However, this may not be true for the supporting systems and equipment, including the HVAC systems and central plant. The core equipment in these systems (chillers, pumps, air handling units, piping circuits, etc.) will tend to remain intact for a more normal 15 to 20 year life cycle even though the systems may be modified frequently as the process they serve changes. Often, an improvement at the central plant will continue to generate savings even though the process it serves changes completely. In the case study, the energy consumption and general configuration of the make up air handling unit will most likely not change even when the tools served by it are removed or modified. The operating point may shift some to reflect the requirements of the new tools, but the system itself and its configuration will probably not change much unless there is a significant change in the way semiconductors are produced that eliminates the need for high air change rates, pressurization of a clean space, and high exhaust/ventilation rates from benches and tools that use hazardous materials like strong acids and bases.
- The process needs associated with the manufacturing of semiconductors are exacting and critical. Contamination is measured in parts per billion and/or molecules per square centimeter. Quality control processes tend to run on detection limits rather than prescribed limits; i.e., if a contaminant is detectable, then the product is unacceptable. To establish some perspective on this, consider the following. If a particle counter were set to count particles in the air that were .5 microns or larger in diameter (a human hair is about 100 microns) and it were placed in operation in a typical office, it would probably count 30,000 to 50,000 particles in the first minute of operation. If that same particle counter were set up in typical higher-end clean room, a count of 100 such particles would be cause for alarm and could result in a process shut-

down until the problem was corrected. As a result, the process managers and engineers tend to resist any change that could in any way impact their product or clean room. They encourage the use of proven design solutions, even if the solutions are 15 or 20 years old and inefficient from an energy standpoint. The achievable savings, while significant, pale in comparison to the losses that can be sustained by ruining product or shipping bad product. When bad product is shipped, not only does the purchaser return it with no payment. They will also probably remove the product manufacturer from their list of approved suppliers at least for several manufacturing cycles. And, to get back on the list, the product manufacturer will have to go through a difficult, intense, time consuming and costly re-qualification process.

- The quick design and construction sequences associated with these facilities and the critical nature of the process tends to promote the use of cookie cutter solutions.

CONCLUSIONS

The efficiency of the HVAC processes that support semiconductor clean rooms have the potential for significant improvement, without impacting clean room qualification requirements, resulting in significant energy and resource savings. Often, these savings could be achieved via relatively inexpensive retrocommissioning efforts, as illustrated by this case study. Evidence suggests that significant savings could also be achieved by extending these concepts, as well as others, to new construction via a design phase commissioning process and a traditional new system commissioning process. However, there are significant and understandable barriers that can interfere with such efforts. The following factors may help overcome these barriers when bringing efficiency improvement ideas to the table for consideration:

- Helping key decision makers understand the difference between the anticipated life cycle of the HVAC equipment (and the persistence of savings generated there) and the process equipment could get them to consider a payback of more than one or two years.
- Modifying systems or process streams that have no direct contact with the product or production process (rather than systems that directly affect or touch the product) may be more appealing to key decision makers since the risks associated with a failure are far smaller.
- Including information that demonstrates an implementation plan that takes the needs of the production cycle and process into account can be helpful in influencing production and process managers.

- In some areas of the country, programs are emerging that provide financial incentives based on reductions in CO₂ emissions associated with energy efficiency improvements. These incentives, when combined with the direct energy savings, can make projects aimed at promoting efficiency even more attractive to financial and accounting people.
- The current rapid escalation in energy prices will most likely generate new interest in ideas that can reduce operating costs by reducing the consumption of energy or other resources. Managers and other decision-makers may be willing to take new risks to gain efficiency because the financial stakes are much higher. In the Northwest, it is anticipated that energy prices will double in the next year or so. Projects that used to have a 4-year payback may suddenly have a 2-year payback. Projects that were not considered viable previously may now be viable.
- An unscheduled power outage at a semiconductor plant can be a catastrophe; processes are shut down in a less than desirable manner, product is ruined and restart can take a day or more. Well designed, well commissioned systems as well as retrocommissioning efforts aimed at existing systems can help minimize the impact of an unscheduled outage by making the system more robust, and in the big picture, will reduce the likelihood of a rolling black-out.

BIBLIOGRAPHY AND REFERENCES

- ¹ *Opportunities for Energy Efficiency in the Northwest Microelectronics Industry*, Northwest Power Planning Council
- ² *Meeting Report – Micro-Electronics Facility Efficiency Workshop*, sponsored by the Northwest Power Planning Council, October 20, 1995, December 8, 1995
- ³ *Conversion Factors for Use in Proposals*, Oregon Climate Trust web site, www.climatetrust.org.
- ⁴ Conversation with Dennis Carson.
- ⁵ This is taken from direct personal experience since I worked at the plant. A restart is anticipated but a firm date has not been selected as of yet. Even in the idle state, the plant uses 20%-30% of the utilities it used in production just running the necessary systems required to maintain a reasonable state of cleanliness.
- ⁶ *1991 ASHRAE Handbook of HVAC Applications*, pp. 41.1-41.38, American Society of Heating, Ventilating, and Air-Conditioning Engineers, Inc.