

**AUTOINDUCER 2-BASED QUORUM SENSING RESPONSE OF  
*ESCHERICHIA COLI* TO SUB-THERAPEUTIC TETRACYCLINE  
EXPOSURE**

A Dissertation

by

LINGENG LU

Submitted to the Office of Graduate Studies of  
Texas A&M University  
in partial fulfillment of the requirements for the degree of

DOCTOR OF PHILOSOPHY

August 2004

Major Subject: Food Science and Technology

**AUTOINDUCER 2-BASED QUORUM SENSING RESPONSE OF  
*ESCHERICHIA COLI* TO SUB-THERAPEUTIC TETRACYCLINE**

**EXPOSURE**

A Dissertation

by

LINGENG LU

Submitted to Texas A&M University  
in partial fulfillment of the requirements  
for the degree of

DOCTOR OF PHILOSOPHY

Approved as to style and content by:

---

Suresh D. Pillai  
(Chair of Committee)

---

Michael E. Hume  
(Member)

---

James J. Zhu  
(Member)

---

Luc R. Berghman  
(Member)

---

Gary R. Acuff  
(Member)

---

Alan R. Sams  
(Head of Department)

---

Rhonda K. Miller  
(Chair of Food Science and Technology Faculty)

August 2004

Major Subject: Food Science and Technology

## ABSTRACT

Autoinducer 2-based Quorum Sensing Response of *Escherichia coli* to Sub-therapeutic Tetracycline Exposure. (August 2004)

Lingeng Lu, B.M.; M.M., Shanghai Medical University

Chair of Advisory Committee: Dr. Suresh D. Pillai

Autoinducer 2 (AI-2) is a quorum sensing signal employed by bacteria to coordinate their response to environmental stresses. The objective of this study was to determine the relationship between presence of AI-2 molecules, exposure to sub-therapeutic tetracycline, the expression of genes associated with the conjugal transfer of antibiotic resistance plasmids, and the conjugal transfer of these plasmids in *Escherichia coli*. The studies showed that AI-2 activity increased in Tet<sup>s</sup> *E. coli* in the presence of tetracycline (2 µg/mL) under both batch and continuous culture conditions. The presence of AI-2 molecules induced tetracycline tolerance development in Tet<sup>s</sup> *E. coli*. The studies showed that the survival rates of Tet<sup>s</sup> *E. coli* exposed to AI-2 molecules were significantly higher compared to the cells not exposed to AI-2 molecules or cells that were exposed to only LB (Lauria-Bertani) broth. Molecular analyses using real-time PCR indicate that the expression of at least one conjugation-associated gene (*trbC*) is increased 9-fold in cells exposed to AI-2 molecules in the presence of sub-therapeutic tetracycline compared to its negative controls. The transconjugation frequency of the plasmid RP4 carrying the *tet(A)* gene increased between 10-100 fold in the presence of AI-2 molecules. In companion studies, AI-2-like activity was detected in fish, tomatoes, cantaloupes, carrots and milk samples. Interestingly, ground beef and poultry meat contained substances that appear to inhibit AI-2 activity. Collectively, these

results highlight the potential importance of bacterial quorum sensing signals such as AI-2 in the response of bacterial cells to environmental stimuli and the possible role of quorum sensing signals in the quality and safety of foods.

## **DEDICATION**

*My doctor of philosophy and this dissertation are dedicated with my greatest gratitude and deepest love to my wife and brothers and sisters-in-law and mother-in-law and in memory of my grandparents and parents*

## ACKNOWLEDGMENTS

My sincerest appreciation is expressed to Dr. Suresh D. Pillai, my advisor, for his academic advice. With patience, attention, wisdom and broad academic knowledge, he led me through this project and all of my graduate studies. The benefits I gained from him are long-term, lasting throughout my future professional career. He is becoming my model for my academic life.

I appreciate Drs. Michael E. Hume, Luc R. Berghman, James J. Zhu and Gary R. Acuff for serving as my committee members and dissertation advisors with consideration, affection, and profound knowledge. The benefits I gained will last throughout my life.

My gratitude also goes to Drs. Bonnie L. Bassler at Princeton University, Venessa Sperandio at Southwestern Medical Center in Dallas, William E. Bentley at University of Maryland, Lai King Ng at National Microbiology Laboratory in Canada, James W. Golden and Duan Liu at Texas A&M University for kindly providing many of the bacterial strains used in the study.

I thank Drs. Allen Byrd, Leon F. Kubena, Tony Poole, Haiqi He and Kenneth Bischoff at USDA, Peter Feng at FDA, Ellen W. Collisson, Alan R. Sams, Rhonda K. Miller, Steven C. Ricke, James Keeton, Lee A. Cartwright, Mr. Robert L. Pottberg, Ms. Elizabeth Hirschler, Ms. Jo Ann Pilkey, and Ms. Pattie F. Horsman for their support and care during my studies.

I also thank my ever-present lab companions: Everado Vega, Kenneth Widmer, James Totten, Matthew Roe, Dr. Seema Endley, Jennon Smith, Dr. Palmy Rajan Jesudhasan, Reema Singh, Kamlesh Soni, Deepak Srikumar, Isabel Espinosa, Jessica Cardenas, Robert Spence and Leroy Cortinas. I am happy to have worked and shared the fun with this group.

My appreciation is extended to my friends at Texas A&M including Michael Sawilowsky, Chen Shuen-ei, Wang Limn, Liu Xingchu, Cao Guangtong, Li Xin, Charles A. Hernandez, Damon Drinnon, Zhang Ping, Shen Shixue, Cai Jianfeng, Zhang Cheng, Li Yuqian, Gu Xinsheng, Xiao Yumin, Zhang Xiaodong and Lai Runzhi. It has been an unforgettable time at Texas A&M University in College Station.

My sincere gratitude also goes to my conversation partners Ms. Hayden Hefflefinger and Ms. Abigail Grass for their inspiration.

I was honored to be a Tom Slick Fellow at Texas A&M University. I wish to thank The Tom Slick Fellowship committee for their valuation. The honor encouraged me to work my best. The completion of this dissertation is not an end but just commencement.

In my life, my dear family is my harbor for sailing, and is my backbone to stand up and bravely face any challenge. Without their selfless support and love, I would not have the chance for climbing the steep mountain of knowledge.

Thanks to God for giving me the wisdom to explore the whole new world, giving me the key to open the treasure of knowledge, and offering me opportunities to experience the spirit of sophisticated culture and science.

## TABLE OF CONTENTS

	Page
ABSTRACT.....	iii
DEDICATION.....	v
ACKNOWLEDGMENTS.....	vi
TABLE OF CONTENTS.....	viii
LIST OF TABLES .....	xi
LIST OF FIGURES.....	xiii
CHAPTER	
I INTRODUCTION.....	1
Rationale .....	1
Overall objective of the study.....	3
Specific objectives .....	3
II LITERATURE REVIEW.....	4
Sub-therapeutic antibiotic administration in animals .....	4
Tetracycline resistance development in enteric bacteria .....	6
Bacterial quorum sensing .....	9
III AUTOINDUCER 2-BASED RESPONSE INDUCES TETRACYCLINE TOLERANCE IN <i>ESCHERICHIA COLI</i> UNDER SUB-THERAPEUTIC EXPOSURE.....	32
Overview.....	32
Introduction.....	33
Materials and Methods.....	35
Results.....	37
Discussion.....	46



CHAPTER	Page
IV	AUTOINDUCER 2 (AI-2) PRODUCTION IN ENTERIC BACTERIA IN RESPONSE TO SUB-THERAPEUTIC ANTIBIOTIC EXPOSURE ..... 50
	Overview..... 50
	Introduction..... 51
	Materials and Methods..... 53
	Results..... 56
	Discussion..... 71
V	AUTOINDUCER 2 (AI-2)-BASED QUORUM SENSING PROMOTES <i>trbC</i> GENE EXPRESSION AND CONJUGAL TRANSFER OF <i>tet(A)</i> GENE IN RESPONSE TO SUB-THERAPEUTIC TETRACYCLINE EXPOSURE IN <i>ESCHERICHIA COLI</i> ..... 74
	Overview..... 74
	Introduction..... 75
	Materials and Methods..... 77
	Results..... 85
	Discussion..... 92
VI	AUTOINDUCER-2 (AI-2)-LIKE ACTIVITY ASSOCIATED WITH FOODS AND ITS INTERACTION WITH ORGANIC ACIDS USED AS FOOD ADDITIVES..... 96
	Overview..... 96
	Introduction..... 97
	Materials and Methods..... 99
	Results..... 103
	Discussion..... 109
VII	A NON-INDOLE-BASED AIRBORNE QUORUM SENSING MOLECULE CAN CONFER TETRACYCLINE TOLERANCE IN PHYSICALLY SEPARATED <i>ESCHERICHIA COLI</i> AND <i>SALMONELLA</i> NEWPORT STRAINS..... 114
	Overview..... 114
	Introduction..... 115
	Materials and Methods..... 117
	Results..... 119
	Discussion..... 124

CHAPTER	Page
VIII	SUMMARY..... 128
	Autoinducer 2-based response induces tetracycline tolerance in <i>Escherichia coli</i> under sub-therapeutic exposure..... 128
	Autoinducer AI-2 activity in response to sub-therapeutic antibiotic exposure in enteric bacteria..... 129
	AI-2-based quorum sensing promotes <i>trbC</i> gene expression and conjugal transfer of <i>tet(A)</i> gene in response to sub-therapeutic tetracycline exposure in <i>Escherichia coli</i> ..... 130
	Autoinducer 2(AI-2)-like activity associated with foods and its interaction with organic acids used as food additives..... 130
	A non-indole-based airborne quorum sensing molecule can confer tetracycline tolerance in physically separated <i>Escherichia coli</i> and <i>Salmonella</i> Newport..... 131
IX	CONCLUSIONS ..... 132
	REFERENCES..... 133
	VITA ..... 152

## LIST OF TABLES

TABLE	Page
3.1	Influence of AI-2 in the survival and tetracycline tolerance of tetracycline-sensitive <i>E. coli</i> Isolate 5..... 45
4.1	Effect of cell-free supernatants of chicken-derived Preempt <sup>®</sup> CF3 culture on the response of the reporter strain <i>V. harveyi</i> BB170 to AI-2 molecules and on the growth of <i>V. harveyi</i> B170..... 67
4.2	<i>In vivo</i> AI-2 activity within poultry chicks in response to antibiotic challenge ..... 69
4.3	Effect of cell-free filtrates of chicken cecal contents on response of reporter strain <i>V. harveyi</i> BB170 to AI-2 molecules ..... 70
5.1	Strains and plasmids used in this study ..... 78
5.2	Primers used for conjugation-associated gene expression using real-time PCR ..... 81
5.3	Transconjugation frequency of IncP plasmid RP4 in <i>E. coli</i> as affected by exposure to AI-2 containing cell free supernatant (CFS) ..... 88
5.4	Relative quantitation of <i>traI</i> and <i>trbC</i> gene mRNA level using real-time PCR ..... 91
6.1	AI-2 activity and indigenous bacterial populations in produce rinses and food extracts ..... 104
6.2	Inhibition of AI-2 activity by food extracts ..... 105
6.3	AI-2 activity of selected food additives..... 107
6.4	Inhibition of AI-2 activity by selected food additives..... 108
6.5	Effect of food additives on the growth of the reporter strain <i>V. harveyi</i> BB170 ..... 108
7.1	Tetracycline tolerant sub-populations in Tet <sup>s</sup> <i>E. coli</i> and Tet <sup>s</sup> <i>S. Newport</i> when exposed to airborne quorum sensing molecules ..... 120

TABLE	Page
7.2 Tetracycline tolerant sub-populations (CFU) in Tet <sup>s</sup> <i>E. coli</i> Isolate 5 when exposed to airborne quorum sensing molecules .....	122

## LIST OF FIGURES

FIGURE		Page
2.1	Selected oligopeptides used as signals by Gram-positive bacteria (A) <i>Staphylococcus aureus</i> and (B) <i>Enterococcus faecalis</i> .....	11
2.2	Structure of selected AI-1 molecules in Gram-negative bacteria.....	13
2.3	Structure of AI-2 molecule(s) in Gram-negative bacteria.....	15
2.4	The de novo synthesis of AI-2 molecules in Gram-negative bacteria .....	16
2.5	AI-1- and AI-2-dependent quorum sensing systems (system 1 and system 2) in Gram-negative bacteria .....	19
2.6	Structures of AI-2 analogs .....	31
3.1	Relative AI-2 activity and growth curve of tetracycline-resistant <i>E. coli</i> Isolate 1 .....	38
3.2	Relative AI-2 activity and growth curve of tetracycline-resistant <i>E. coli</i> Isolate 12 .....	39
3.3	Relative AI-2 activity and growth curve of tetracycline-sensitive <i>E. coli</i> Isolate 5 .....	40
3.4	Normalized relative AI-2 activity in tetracycline-resistant and sensitive <i>E. coli</i> strains at 2 h in the presence and absence of tetracycline exposure .....	42
3.5	Normalized relative AI-2 activity in tetracycline-resistant and sensitive <i>E. coli</i> strains at 8 h in the presence and absence of tetracycline exposure .....	43
3.6	Normalized relative AI-2 activity in tetracycline-resistant and sensitive <i>E. coli</i> strains at 20 h in the presence and absence of tetracycline exposure .....	44

FIGURE	Page
4.1	AI-2 activity and OD <sub>600</sub> in chemostat-cultivated <i>E. coli</i> Isolate 5 in LB broth under anaerobic conditions..... 58
4.2	AI-2 activity and OD <sub>600</sub> in chemostat-cultivated <i>E. coli</i> Isolate 5 in LB broth plus 0.5% glucose under anaerobic conditions ..... 59
4.3	AI-2 activity and OD <sub>600</sub> in chemostat-cultivated <i>E. coli</i> Isolate 5 exposed to sub-therapeutic chlortetracycline (2 µg/mL) in LB broth ..... 60
4.4	AI-2 activity and OD <sub>600</sub> in chemostat-cultivated <i>E. coli</i> Isolate 5 exposed to sub-therapeutic chlortetracycline (2 µg/mL) in LB broth plus 0.5% glucose under anaerobic conditions ..... 61
4.5	Normalized relative AI-2 activity of chemostat-cultivated <i>E. coli</i> Isolate 5 exposed to sub-therapeutic chlortetracycline in LB broth ..... 62
4.6	Normalized relative AI-2 activity of chemostat-cultivated <i>E. coli</i> Isolate 5 exposed to sub-therapeutic chlortetracycline in LB broth plus 0.5% glucose ..... 63
4.7	AI-2 activity and OD <sub>600</sub> in chemostat-cultivated chicken-derived Preempt <sup>®</sup> CF3 in LB broth at 39°C under anaerobic conditions..... 65
4.8	AI-2 activity and OD <sub>600</sub> in chemostat-cultivated chicken-derived Preempt <sup>®</sup> CF3 exposed to sub-therapeutic level of chlortetracycline (4 µg/mL) in LB broth ..... 66
5.1	Growth pattern of <i>E. coli</i> AM0076 (donor cells) and <i>E. coli</i> AM1087 (recipient cells) at 37°C in LB broth ..... 86
5.2	Relative AI-2 activity and <i>E. coli</i> populations at 37°C in batch culture ..... 87
5.3	Plasmid profile analysis of representative transconjugants by PFGE ..... 89
5.4	PCR amplification for <i>tet(A)</i> gene on plasmid RP4 in transconjugants ..... 90

FIGURE	Page
7.1	Experimental set up for the airborne quorum sensing-based induction of tetracycline tolerance in <i>E. coli</i> and <i>S. Newport</i> with a Bi-partite Falcon I Petri plate ..... 118
7.2	Morphology of induced colonies on tetracycline-supplemented agar by airborne quorum sensing molecules ..... 123

# CHAPTER I

## INTRODUCTION

### RATIONALE

Antibiotics are used widely in clinical medicine for treating infections, and also at sub-therapeutic concentrations as animal growth promoters (Huges and Heritage, 2002; Roberts, 1996). Tetracyclines are used routinely in animal production (Roberts, 1996). They are bacteriostatic agents, which inhibit bacterial growth by preventing the binding of aminoacyl-tRNA to the ribosome, thereby interfering with protein synthesis. The overuse of tetracyclines has been thought to contribute to the emergence of tetracycline resistance in pathogens and commensal bacteria (Levy, 1986; Roberts, 1996; Blake et al., 2003a, 2003b; Bahl et al., 2004). Bacteria become resistant to tetracyclines either through mutations in 16S rRNA or by the horizontal transfer of tetracycline resistance determinants (*tet* genes). These genes mediate tetracycline resistance by the mechanisms of efflux pumps, ribosome protection or enzymatic degradation. Tetracycline resistance based on mutations in 16S rRNA is rare (Chopra and Roberts, 2001; Trieber and Taylor, 2002). In contrast, *tet* genes are thought to be the primary mechanism mediating resistance (Roberts, 1996; Trieber and Taylor, 2002).

Quorum sensing can be defined as a process by which bacterial cells coordinate their responses to various stimuli by means of signal molecules termed autoinducers (AI). Autoinducers have been shown to accumulate in cells and their surroundings as the cell density increases (Miller and Bassler, 2001; Sperandio et al., 2001, 2002a, 2002b).



This coordinated regulation of gene expression could permit a group of bacteria to function as a “single unit”, allowing them to withstand environmental stresses and host defense mechanisms. Autoinducer molecules act upon specific sets of target genes through different regulatory mechanisms, resulting in the modulation of a number of cellular functions such as bioluminescence, pathogenicity, biofilm formation, competence development and transconjugation (Miller and Bassler, 2001; Oger and Farrand, 2002; Sperandio et al., 2001, 2002a, 2002b; Steinmoen et al., 2002). *Escherichia coli* produce AI-2, but not AI-1 molecules (Surette and Bassler, 1998). It has been shown that the production of AI-2 is influenced by a number of environmental factors (DeLisa et al., 2001a, 2001b). The relationship between antibiotic exposure and the production and sensing of quorum sensing signals, however, is still largely unknown. Furthermore, the role of quorum sensing AI-2 signals in the transfer of antibiotic resistance genes (e.g. *tet* genes) is still poorly understood. The realization that microbial contaminants can be transmitted from the farm to the table through foods also raises questions about the potential activity of microbial quorum sensing associated with foods and food ingredients. Since quorum sensing mediates a wide variety of bacterial processes such as virulence expression, biofilm formation and plasmid conjugation, I hypothesized that exposure to sub-therapeutic concentrations of tetracycline and the development of tetracycline resistance are related, and mediated via AI-2-based quorum sensing signals. This study was aimed specifically at identifying the relationships in *E. coli* that exist between exposure to sub-therapeutic concentrations of tetracycline, acquisition of tetracycline resistance genes, and the expression of genes related to conjugation, as a function of the presence of AI-2 signals. Complementary studies investigating the

possible presence of AI-2-like molecules or activity on selected food and by food additives were also conducted. The overall rationale of these studies was that if the above relationships are understood, it would be possible to design specific strategies to reduce the emergence of antibiotic resistance phenotypes among enteric bacteria by modulating quorum sensing mechanisms either at pre-harvest or post-harvest stages of food production and processing.

### **OVERALL OBJECTIVE OF THE STUDY**

The overall objective of this study was to identify the relationships existing between exposure to sub-therapeutic concentrations of tetracycline, the development of tetracycline resistance, expression of specific microbial genes and the exposure to quorum sensing-related AI-2 molecules in *E. coli*.

### **SPECIFIC OBJECTIVES**

1. To understand AI-2 activity in tetracycline resistant and tetracycline sensitive *E. coli* under batch culture conditions.
2. To understand AI-2 activity in chemostat-cultured *E. coli* and enteric bacteria under conditions to simulate the gastrointestinal tract of poultry.
3. To identify the relationship between exposure to sub-therapeutic concentrations of tetracycline, exposure to AI-2 molecules, conjugation-related gene expression in *E. coli*, and conjugal acquisition of tetracycline resistance encoding genes.
4. To screen selected foods for the presence of AI-2 molecules and identify which certain food ingredient can mimic AI-2 activity.

## **CHAPTER II**

### **LITERATURE REVIEW**

#### **SUB-THERAPEUTIC ANTIBIOTIC ADMINISTRATION IN ANIMALS**

Antibiotics such as tetracyclines are used at sub-therapeutic concentrations as growth promoters in animal feed. Most food animals around the world receive antibiotics at sub-therapeutic concentrations via feeds. According to the European Federation of Animal Health (FEDESA) data, more than 1,500 tons of antibiotics are used annually for animal growth promotion (Ungemach, 2000). In Denmark alone, 107 tons of antibiotics were prescribed in 1997 for animal growth promotion, and in the Netherlands sub-therapeutic antibiotic usage amounted to 300 tons (Van den Bogaard, 1997). In Canada, approximately 10 million kilograms of antibiotics are used each year in agricultural or aquacultural production (Stevenson et al., 2003; Khachatourians, 1998). In the United States, it is estimated that over 20 million pounds of antibiotics are used each year in animal husbandry (Animal Health Institute, 2003), and that the amount of antibiotics used annually for agriculture constitutes as much as 70% of antimicrobial drug consumption (Mellon et al., 2001). The antibiotics are usually fed to animals over extended periods of the animals' lives. Tetracyclines are added to feeds at low concentrations (10-50 g/ton), and withdrawn only 3 days prior to slaughter in chickens and only 5 days prior to slaughter in cattle and swine (U. S. FDA, 2001). Sub-therapeutic concentrations of antibiotics are defined in the United States as being "less than 200 grams/ton of feeds" (Chopra and Roberts, 2001). Adding low concentrations of antibiotics to animal feeds helps in increased growth and feed efficiencies in farm animals such as pigs, cattle and

poultry (Chopra et al., 1992; Committee on Drug Use in Food Animals, 1999). The precise mechanisms by which they function are still poorly understood. The use of antibiotics at sub-therapeutic concentrations in animals, however, appears to enhance vitamin production by gastrointestinal microorganisms, eliminate subclinical populations of pathogenic organisms, and increase the intestinal absorption of nutrients (Committee on Drug Use in Food Animals, 1999).

The use of chlortetracycline at sub-therapeutic concentrations was first discovered in 1949 to increase growth and enhance feed utilization in poultry (Stockstad, et al., 1949). The growth-promoting properties of tetracyclines in poultry were confirmed and soon were repeated in swine and cattle, leading to the development of chlortetracycline and oxytetracycline as animal growth promoters (Gustafson and Kiser, 1985). In the United States, FDA approved use of chlortetracycline and oxytetracycline as feed additives in 1951 and in 1953, respectively (Institute of Medicine, Division of Health Promotion and Disease Prevention, 1998). Currently, antibiotics that are approved for use at sub-therapeutic concentrations for growth promotion in the United States include ampicillin, chlortetracycline, dihydrostreptomycin, spectinomycin, tylosin, penicillin, monensin, oleandomycin, roxarsone, efrotomycin and bambarmycin (Committee on Drug Use in Food Animals, 1999).

The emergence of antibiotic resistant organisms caused by widespread antibiotic use for clinical treatment, prophylactic purposes and as animal growth promoters has become a major concern in human and veterinary medicine (National Academy of Science, 1999). The development of resistance in zoonotic bacteria consequently increases the risk of treatment failures (Holmberg et al., 1984; Phillips et al., 2004).

Based on the relationship between sub-therapeutic feeding of tetracyclines and other antibiotics to farm animals and the development of resistant human isolates, the feeding of tetracyclines and other antibiotics (at sub-therapeutic concentrations as growth promoter) has been banned in Europe (Chopra and Roberts, 2001; Casewell et al., 2003). The proponents of antibiotic use have, however, argued that the ban of antibiotics as growth promoters in Europe has been at the cost of animal welfare, since increased mortality and morbidity have driven up the demand for therapeutic use different antibiotics (Casewell et al., 2003; Phillips et al., 2004). The sales of therapeutic antibiotics such as tetracyclines have increased by 36 tons in Europe between 1999 and 2000, after the European Union banned the use of growth promoters in 1999. There is currently no ban on the use of antibiotics such as tetracycline at sub-therapeutic concentrations in the United States (U.S. FDA, 2004).

### **TETRACYCLINE RESISTANCE DEVELOPMENT IN ENTERIC BACTERIA**

Tetracyclines are a group of broad-spectrum antibiotics that are used routinely in therapy and as animal growth promoters due to its relative low cost (Schnappinger and Hillen, 1996; Teuber, 2001). A survey by the Animal Health Institute (AHI, 2003) showed that over 6.6 million pounds of tetracyclines were used annually during 2000-2002 in animal husbandry in the United States. The widespread use of tetracyclines has been thought to contribute to the emergence of tetracycline resistance in pathogens and commensal bacteria (Levy, 1986; Roberts, 1996; Blake et al., 2003a, 2003b; Bahl et al., 2004). Long periods of tetracycline administration at sub-therapeutic concentrations can cause a selective pressure on the commensal bacteria to become resistant. These populations, in turn, can serve as potential reservoirs of resistance-encoding genes for

horizontal gene transfer (Khachatryan et al., 2004; Blake et al., 2003a; Bahl et al., 2004; Shoemaker et al., 2001).

Studies show that bacteria become resistant to tetracyclines either through mutations of 16S rRNA or by the horizontal transfer of tetracycline resistance determinants (*tet* genes). Tetracycline resistance based on mutation in 16S RNA is rare (Chopra and Roberts, 2001; Trieber and Taylor, 2002). In contrast, the *tet* genes encoding for efflux pumps, ribosome protection, or enzymatic degradation are major mechanisms that mediate tetracycline resistance (Roberts, 1996; Trieber and Taylor, 2002). These genes have frequently been identified on conjugative mobile elements such as plasmids, transposon and integrons. Examples of mobile elements include the *tet(Q)* in conjugative transposon CTnGERM1 (Wang et al., 2003), *tet(M)* in Tn5397 (Roberts et al., 1999), *tet(A)* in IncP plasmid RP4 (Pansegrau et al., 1994), *tet(G)* within a putative integron (Briggs Fratamico, 1999), and *tet(M)*, *tet(L)*, *tet(S)* in a member of the Tn916-Tn1545 family of transposons (Huys et al., 2004). It appears that *tet* genes are transferred via horizontal gene transfer mechanisms such as conjugation between bacteria cells.

Conjugation is the transmission of a single stranded DNA through a mating apparatus between a donor and a recipient cell, resulting in dissemination of antibiotic resistance. Two arbitrary steps, namely mating pair formation (Mpf) and the transfer of nicked single stranded plasmid DNA (in the relaxosome), are involved in the process of conjugation. Walmsley (1976) reported that pilus formation is a limiting step in mating apparatus formation under normal physiological conditions. The plasmid RP4 has been used extensively to study replication and regulation of gene expression (Jagura-Burdzy et al., 1991; Kornacki et al., 1993; Pinkney et al., 1988; Zatyka et al., 1994). RP4 genes and

their sequences have been well described (Lessel et al., 1992b; Ziegelin et al., 1991). The plasmid RP4 consists of two distinct regions, designated Tra1 and Tra2, encoding essential transfer functions (Lessl et al., 1992a, 1992b). Genes such as *trbB*, *trbC*, *trbE*, *trbG* and *trbL*, located in Tra2 region are responsible for encoding the essential components for Mpf system (Lessl et al., 1993). The *trbC*-encoded protein has been identified as the precursor of pilin, which is subsequently processed to form the pilus (Eisenbrandt et al., 1999; Sherburne et al., 2000). Novotny and Lavin (1971) reported that pilation reaches maximum at the end of the exponential phase of cell growth. In the Tra1 region, *traI* gene encodes the relaxase enzyme. This enzyme binds to *oriT* of plasmid DNA to form the relaxosome, nicking the DNA to initiate its transfer when the appropriate signal indicating the formation of a stable mating complex is received. The signal could arise from the binding of pilus on a donor cell and receptor on a recipient cell, and could be part of an Mpf component that resides at the outer-membrane side of the mating apparatus structure (Haase et al., 1995; Street et al., 2003).

Studies have shown that biotic and abiotic factors such as cell density, growth phase of the donors and recipients, the presence of antibiotics, and nutrient levels control the conjugation transfer frequency (Smith, 1975, 1977a, 1977b; Fernandez-Astorga et al., 1992; Muela et al., 1994; Blake et al., 2003b; Whittle et al., 2002a, 2002b; Bahl et al., 2004). Conjugation frequency reaches maximal levels when donor-to-recipient ratios range from 1 to 10 (Fernandez-Astorga et al., 1992), and when donor cells are at exponential or early stationary phase of growth (Muela et al., 1994; Blake et al., 2003b). It has been reported recently that conjugative plasmid-harboring bacteria tend to form biofilms in which gene transfer frequency is enhanced (Ghigo, 2001; Molin and Tolker-

Nielsen, 2003). Whittle et al. (2002b) reported the presence of tetracycline at sub-therapeutic levels results in an increase in transfer protein expression and a concomitant increase in the transfer frequency. The transfer rate of conjugative Tn916 increases in the presence of tetracycline (Showsh and Andrews, 1992). Very recently, an *in vivo* study suggested that the number of transconjugants was significantly higher for animals fed with tetracycline at sub-therapeutic levels than for those not exposed to tetracycline (Bahl, et al., 2004).

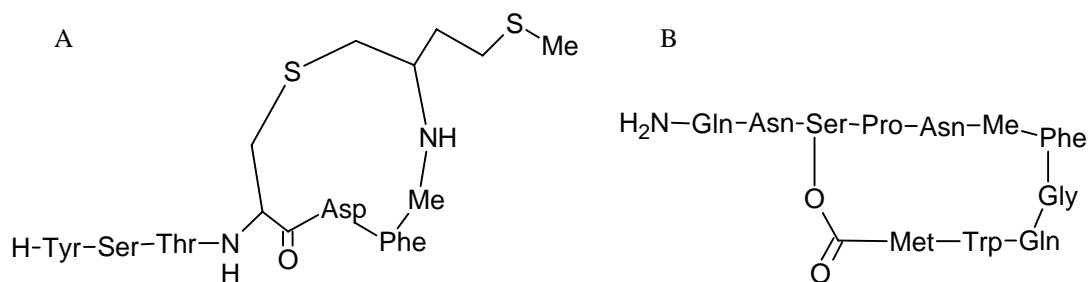
## **BACTERIAL QUORUM SENSING**

Research over the last 20 years has revealed that bacterial cells can communicate with each other via the production and the sensing of signal molecules termed autoinducers (AI) (Bassler et al., 1994). It is thought that bacterial cells can coordinate their behavior by altering gene expression to withstand environmental stresses and host defenses (DeLisa et al., 2001b). This process of coordinately regulating gene expression via the production, release and perception of autoinducers is now known as “quorum sensing”. This phenomenon was the first observed and described in marine luminescent bacteria of *Vibrio fischeri* and *V. harveyi* (Nealson et al., 1970; Nealson and Hastings, 1979). In these bacteria, light production is activated only when the cell population density reaches a critical value. Presently, it is believed that quorum sensing is a general mechanism for coordinating the control of gene expression in Gram-negative and Gram-positive bacteria. A wide variety of physiological processes, including biofilm formation (Davies et al., 1998; Miller and Bassler, 2001), virulence (Kanamaru et al., 2002; Sperandio et al., 2001, 2002a), antibiotic biosynthesis (McGowan et al., 1995; Williams



et al., 1992), development of competence (Lee and Morrison, 1999; Steinmoen et al., 2002) and conjugal transfer of plasmids (Oger and Farrand, 2002), are associated with bacterial quorum sensing.

**Bacterial autoinducer molecules.** A class of small molecular weight molecules is produced during bacterial metabolism. These molecules were thought of originally as “waste” during the detoxification of bacterial cells (Taga et al., 2003). Studies over the past several years have revealed, however, that at least some of these molecules can serve as “signals”, influencing gene expression when their concentrations reach a critical value (Bassler, 1999; Surette et al., 1999; Sperandio et al., 2001; DeLisa et al., 2001c; Martino, et al., 2003; Wang et al., 2001). The molecules have been termed as autoinducers, since they are produced by bacterial cells and can also diffuse back into cells to help them survive environmental changes via alterations in their gene expression patterns (DeLisa et al., 2001b). Generally, Gram-positive bacteria utilize oligopeptides as signals for communication (Miller and Bassler, 2001). These signals are post-translationally modified peptides (**Fig. 2.1**) and are exported outside bacterial cells via specific ATP-binding cassette (ABC) transporters (Zhang et al., 2004). The expression of genes in Gram-positive bacteria is regulated by these signals through a two-component signal transduction system (Lazazzera et al., 1997; Soloman et al., 1995). In contrast, Gram-negative bacteria use diffusible acylated homoserine lactones (AI-1) and furansyl-borate diester (AI-2) as signals (Miller and Bassler, 2001; Chen et al., 2002).

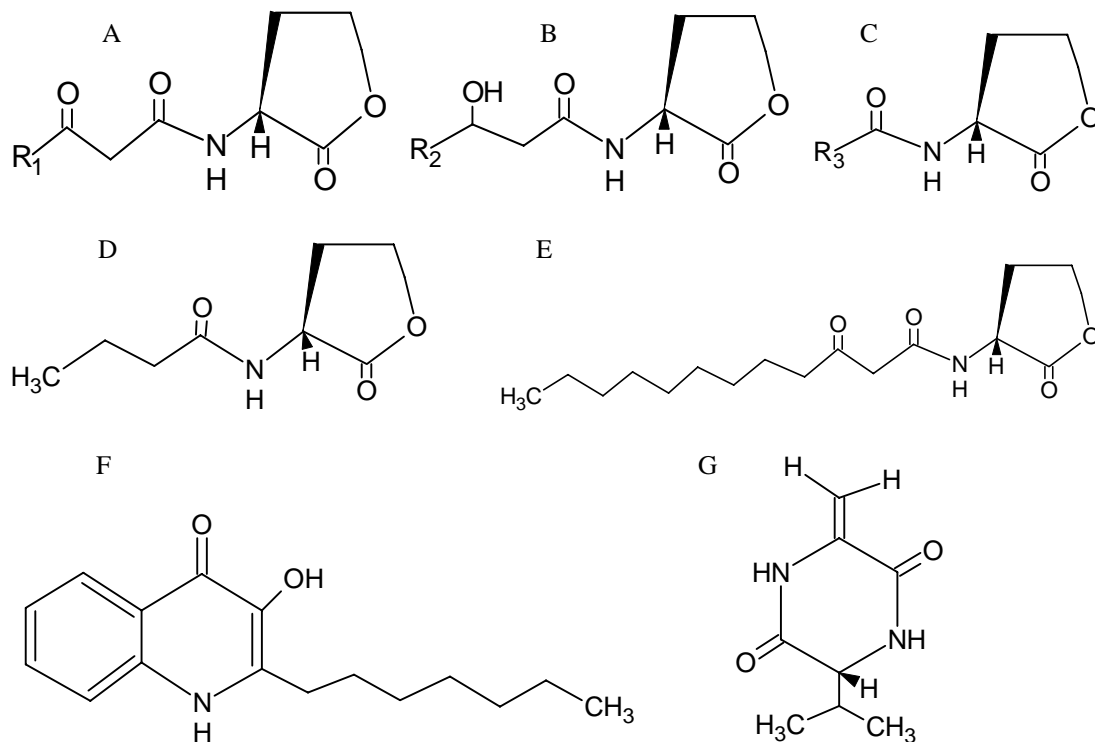


**Fig. 2.1.** Selected oligopeptides used as signals by Gram-positive bacteria (A) *Staphylococcus aureus* and (B) *Enterococcus faecalis* (the gelatinase biosynthesis-activating pheromone) (Modified from Camara et al., 2002).

**Autoinducer 1 molecules.** AI-1 molecules are a group of acylated homoserine lactones (Fig. 2.2). They share common homoserine lactone rings that are covalently coupled with acyl-side chains of variable length, saturation and oxidation status (Figs. 2.2A, 2.2B and 2.2C). The acyl-side chain usually ranges from 4 to 14 carbons in length, and may contain not only a hydroxyl or oxo group at C3, but also it can be saturated or unsaturated. The LuxI-type autoinducer synthase is responsible for the formation of AI-1. *In vitro* and *in vivo* studies have showed that the homoserine lactone rings are derived from S-adenosylmethionine (Jiang et al., 1998; More et al., 1996). The acyl-chain is provided via the appropriately charged acyl-acyl carrier protein (acyl-ACP) or acyl-coenzyme A (acyl-CoA) (Jiang et al., 1998; More et al., 1996). Odd numbered acyl chains are believed to originate by a different pathway that uses propionyl-CoA and malonyl-CoA as respective starter and extender units (Lithgow et al., 2000). Recently, a quinolone-like AI-1 molecule was found in *Pseudomonas*, termed as the *Pseudomonas* quinolone signal (PQS) (Fig. 2.2F). In this molecule a quinolone structure replaces the homoserine lactone ring (Pesci et al., 1999). The precursor protein responsible for its

synthesis is still unknown. The quinolone structure is thought to be provided by the tryptophan pathway (Pesci et al., 1999). Another novel AI-1 molecule is diketopiperazine (**Fig. 2.2G**) (Camara et al., 2002; Holden et al., 1999), which can activate or antagonize LuxR-mediated quorum sensing systems. The proposed regulatory mechanism is that diketopiperazine competes for the AI-1 binding site on LuxR-type regulator (Holden et al., 1999). However, the physiological function of diketopiperazine is still unknown.

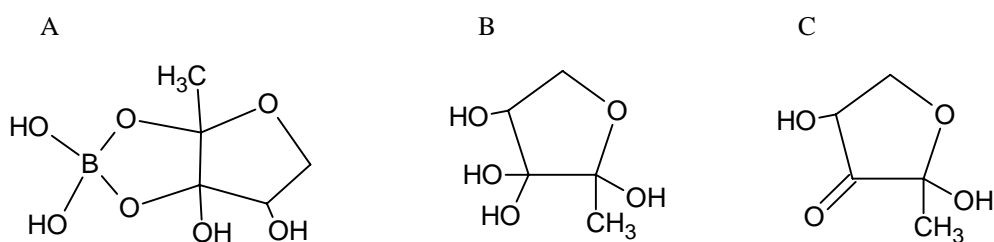
AI-1 molecules are soluble organic molecules, which can be isolated using organic extraction methods. Short-chain AI-1 molecules such as C4-HSL can diffuse freely into and out of cells (Pearson et al., 1999). Although longer chains such as 3OC12-HSL can diffuse into the surrounding environment and re-enter cells by diffusion, their export out of the cells is thought to be enhanced by the *mexAB-OprM* loci and perhaps other efflux pumps (Evans et al., 1998; Pearson et al., 1999; Rahmati et al., 2002). AI-1-based quorum sensing is thought to be strictly specific for *intra-species* communication, regulating light production in *Vibrio harveyi*, biofilm formation in *Pseudomonas aeruginosa*, conjugation in *Agrobacterium tumefaciens*, and antibiotic production in *Erwinia carotovora* (Bollinger et al., 2001; McGowan et al., 1995; Oger and Farrand, 2002). Recently, however, Smith and Ahmer (2003) reported that *Salmonella* spp. can use AI-1 produced by other species as a signal molecule.



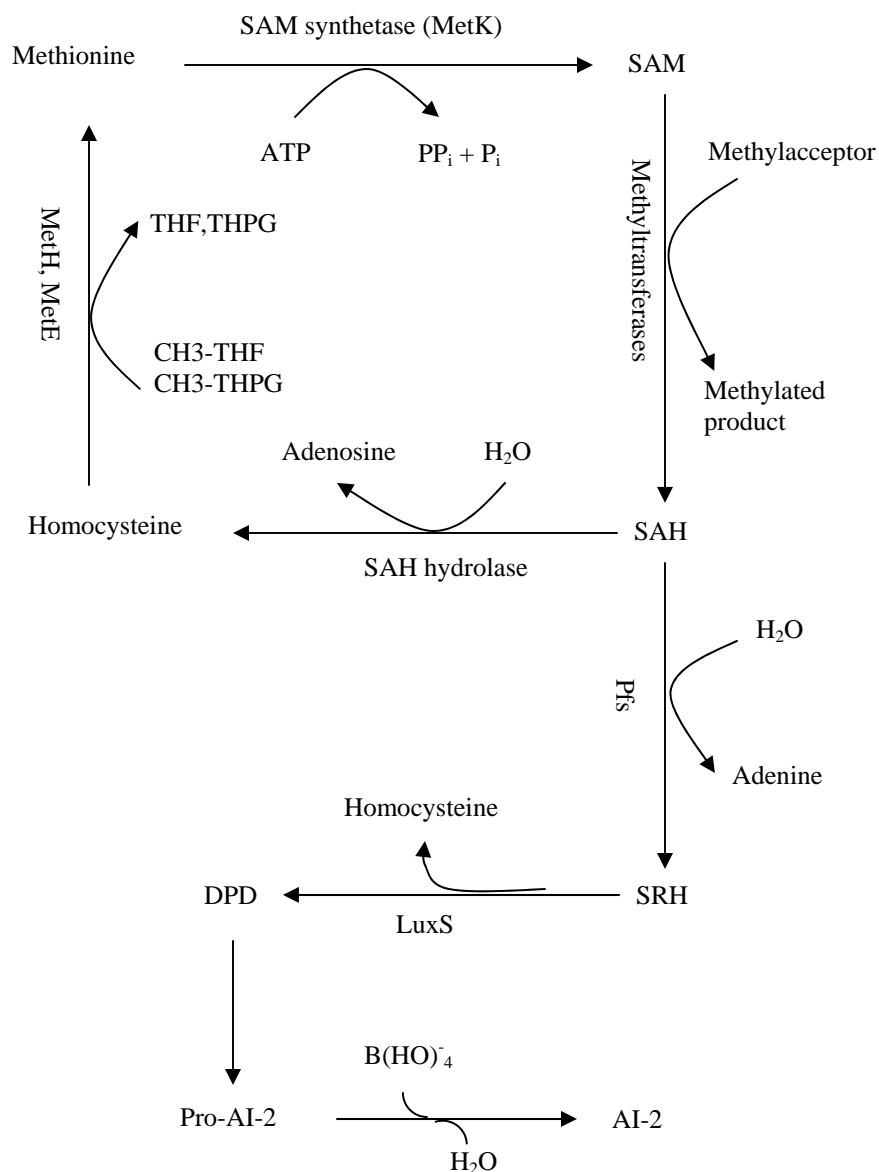
**Fig. 2.2.** Structure of selected AI-1 molecules in Gram-negative bacteria. General structures of acylated homoserine lactone family of AI-1 molecules with either (A) –oxo, (B) –hydroxyl, or (C) no substitute at the carbon 3 of the acyl side chain. R<sub>1</sub>, R<sub>2</sub> and R<sub>3</sub>, various numbers of carbons within the acyl-side chain. (D) *N*-butanoylhomoserine lactone (C4-HSL) and (E) *N*-(3-oxododecanoyl) homoserine lactone (3-oxo-C12-HSL) are produced by *Pseudomonas aeruginosa*. (F) 2-heptyl-3-hydroxy-4-quinolone (pseudomonas quinolone signal molecule, (PQS)), and (G) the diketopiperazine (DKP) are novel signals also produced by *P. aeruginosa* (Modified from Camara et al., 2002).

**Autoinducer 2 molecules.** AI-2 are acid-stable and base-labile molecules, that are heat tolerant to 80°C, but not to 100°C (Surette and Bassler, 1998). They are produced by a large number of bacteria including as *E. coli*, *Salmonella* serotypes, *Campylobacter* spp., *Vibrio cholerae* and *Shigella* spp. (Cloak et al., 2002; Surette and Bassler, 1998; Surette et al., 1999). AI-2 is considered a universal quorum sensing signal, which is involved in interspecies cell-to-cell communication (Miller and Bassler, 2001). The AI-2 molecule is hypothesized to be furanosyl borate diester (**Fig. 2.3A**) (Chen et al., 2002), a soluble organic molecule. However, it is yet to be completely purified (Surette and Bassler, 1998). Different types of AI-2 molecules could be formed (**Fig. 2.3B, 2.3C**) in the absence of boron (Bassler, 2004, personal communication). The AI-2 biosynthetic pathway originates with methionine and ATP (**Fig. 2.4**), which form the substrates for S-adenosylmethionine (SAM). SAM is an essential cofactor in bacterial physiological activities, providing the methyl group for DNA, RNA and protein synthesis. In this process, an intermediate S-adenosylhomocysteine (SAH) is produced, which is toxic to cells, and is hydrolyzed immediately by the nucleosidase enzyme 5'-methylthioadenosin/S-adenosylhomocysteine nucleosidase (Pfs) for detoxification. One product of SAH, S-ribosylhomocysteine (SRH) is catalyzed by LuxS protein to form 4, 5-dihydroxy-2, 3-pentanedione (DPD), and consequently rearranged to form pro-AI-2 (Chen et al., 2002; Schauder et al., 2001). In the presence of boron, pro-AI-2 undergoes an adduct reaction with borate to generate an AI-2 signal molecule. AI-2 molecules are thus side-products during bacterial metabolism. In the synthesis of AI-2 from the S-adenosylmethionine substrate, at least three enzymes, namely methyltransferase, nucleosidase Pfs and LuxS synthase, are involved. It has been reported that a *pfs* mutant,

that promotes the accumulation of SAH, exhibits severe growth defects in cells with this mutation (Cadieux et al., 2002). This outcome could result from the toxicity of SAH, and from inhibition of SAM-requiring reactions by SAH. The accumulation of SRH, however, does not cause toxicity problems. Beeston and Surette (2002) found that *luxS* mutants show no growth defects in comparison with wild-type *S. Typhimurium* or *E. coli*. This observation suggests that AI-2 is a final product in the detoxification process. The production of AI-2 is proportional to the availability of SAH in cells, which is dependent on intercellular concentrations of methionine and SAM (Beeston and Surette, 2002). The expression of the *pfs* gene is not affected transcriptionally by the feedback of AI-2 or SRH levels (Beeston and Surette, 2002). However, the presence of glucose in the growth medium dramatically influences *pfs* gene expression. The expression of *pfs* gene reaches its maximum in exponential-phase cells in LB plus 0.5% glucose, and declines significantly when cells enter stationary phase (Beeston and Surette, 2002). The change in AI-2 pattern in cells correlates with the pattern in *pfs* expression.



**Fig. 2.3.** Structure of AI-2 molecule(s) in Gram-negative bacteria. (A) furanosyl borate diester, (B) trihydroxy-methyl furanone, and (C) dihydroxy-methyl furanone (Modified from Chen, et al., 2002; Personal communication with Bassler, 2004).



**Fig. 2.4.** The de novo synthesis of AI-2 molecules in Gram-negative bacteria. Methionine is converted to S-Adenosylmethionine (SAM) by SAM synthetase (MetK) with the cost of one molecule of ATP. SAM is catalyzed by SAM-dependent methyltransferase to produce S-adenosylhomocysteine (SAH). In some bacteria, e.g. *Pseudomonas aeruginosa*, SAH is hydrolyzed by SAH hydrolase to homocysteine and adenosine, and homocysteine is recycled to form methionine. Other bacteria, e.g. *E. coli*, produce S-ribosylhomoserine (SRH) catalyzed by 5'-methylthioadenosin/S-adenosylhomocysteine nucleosidase (Pfs). LuxS catalyzes SRH to produce DPD (4, 5-dihydroxy-2, 3-pentanedione) and homocystosteine. DPD is converted to pro-AI-2 by rearrangement, and subsequently boron is added to produce AI-2 molecules (Modified from Chen et al., 2002; Winzer et al., 2002a).

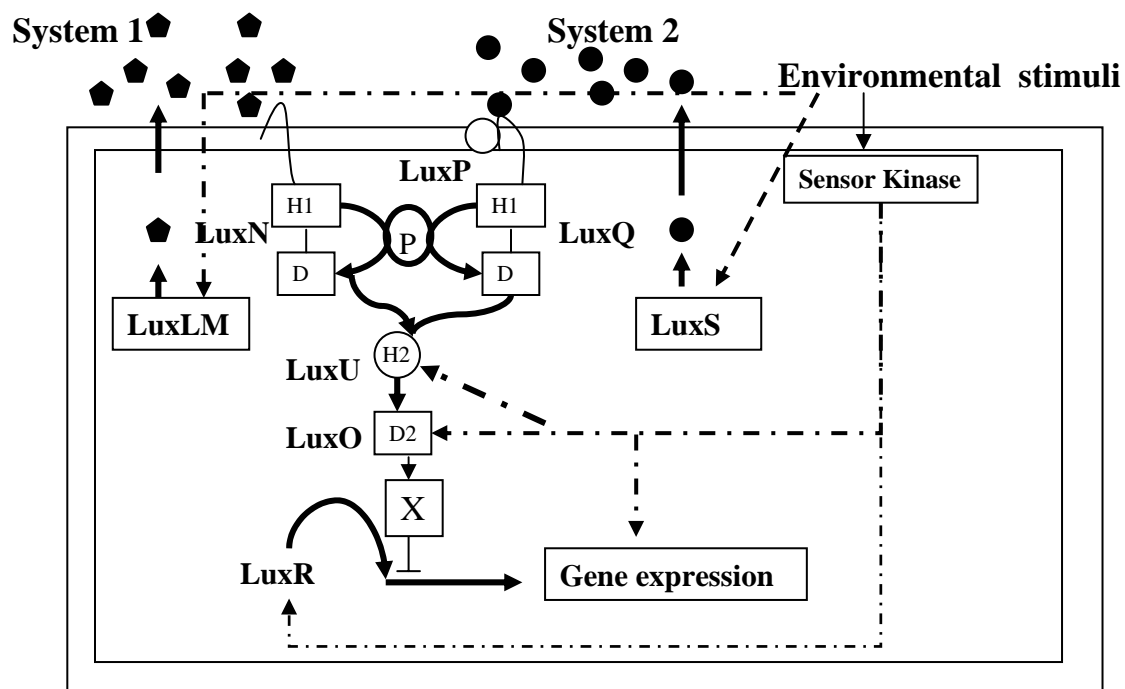
LuxS protein is required for AI-2 synthesis. The sequence of *luxS* gene is highly conserved across species (Xavier and Bassler, 2003; Cloak et al., 2002). Therefore, it is not surprising that AI-2 has been proposed to serve as a 'universal' signal for inter-species communication (Miller and Bassler, 2001; Surette and Bassler, 1998; Surette et al., 1999). The protein LuxS catalyzes SRH to generate homocysteine and AI-2 molecules (Schauder et al., 2001). Inactivation of *luxS* gene results in lack of AI-2 production. However, AI-2 does not inhibit the expression of the *luxS* gene through feedback loop response (Beeston and Surette, 2002). The decline in AI-2 activity observed at the stationary phase of cell growth is probably due to degradation or uptake of AI-2 by the cells and not due to a decrease in LuxS protein. Hardie et al. (2003) reported that LuxS is functional in cells even at the stationary phase of growth and in the absence of glucose in the growth medium. The authors have also reported that the laboratory *E. coli* strains do not produce AI-2 beyond 7 h in the absence of glucose and beyond 24 h growth in the presence of 0.4% glucose. No AI-2 activity was detectable in the extracts of these strains. However, when these cell extracts were incubated with SAM, SAH or SRH, AI-2 molecules were produced and its activity was more than 100-fold. Similar results were reported stating that LuxS levels in the cells at the stationary-phase were not significant difference from those in cells at the exponential-phase (Beeston and Surette, 2002).

**Quorum sensing pathways in Gram-negative bacteria.** Quorum sensing occurs widely in both Gram-negative and Gram-positive bacteria, and controls gene expression in response to changes in environmental factors and cell density (Ahmer et al., 1998; Lee and Morrison, 1999; Miller and Bassler, 2001; Sperandio et al., 2001; Steinmoen et al.,



2002). Given that switch-on or switch-off of a gene is controlled by its corresponding regulator, it is postulated that bacterial cells utilize two or more quorum sensing systems to sense environmental stimuli (Taga and Bassler, 2003). Two quorum-sensing systems, namely system 1 and system 2, have been well defined in the Gram-negative bacteria *V. harveyi*. These systems were studied initially in *V. harveyi*, and they use AI-1 and AI-2 molecules as signals, respectively. They work in parallel to regulate discrete groups of genes by monitoring concentrations of autoinducers in response to environmental stimuli and cell density. The quorum sensing systems in *V. harveyi* are composed of two regulatory components, one is an autoinducer sensor, and the other is a LuxR-type regulator (Miller and Bassler, 2001). The former works as receptors on cell membrane to bind autoinducers, and transfer environmental signals into the cell through phosphorylation cascades to induce gene expression. The latter functions as a transcriptional activator regulating target gene expression by monitoring the signals upstream from the autoinducer sensor.

Bassler and her colleagues (Miller et al., 2002) used the marine bacterium *V. harveyi* as a model to delineate how the two quorum sensing systems control gene expression (**Fig. 2.5**). In the quorum sensing pathways, LuxO acts as a pivot for both AI-1 and AI-2 systems. Signals from either system must trigger switches between phosphorylation and dephosphorylation of LuxO. At low cell density, when the concentrations of the autoinducers are low, the sensor proteins LuxN for AI-1 and LuxP for AI-2 molecules function as kinases, catalyzing autophosphorylation. Consequently, the phosphate moiety flows from the conserved histidine residues (H1) to conserved



**Fig. 2.5.** AI-1- and AI-2-dependent quorum sensing systems (system 1 and system 2) in Gram-negative bacteria. Integration of AI-1- and AI-2-dependent signaling modules coordinate gene expression in response to environmental stresses and cell density. Pentagons and circles represent AI-1 and AI-2, respectively. The “P” in the circle indicates that signal transduction occurs by the transfer of phosphate in phosphorylation. Growing bacterial cells produce AI-1 and AI-2 molecules, diffusing or exported out of cells to the environment. AI-1 and AI-2 molecules bind their cognate receptors of LuxN and LuxP, respectively. The signals from the environment are relayed by phosphorylation and dephosphorylation to turn on/off target genes through regulator LuxR. The details are shown in text. X (putative repressor) is proposed to be an sRNA (small RNA) (Modified from Withers et al., 2001; Miller et al., 2002; Personal communication, Bassler, 2004).

aspartate residues (D1) in their adjacent response regulator domains, and subsequently to the conserved histidine residue (H2) of LuxU, and finally to the appropriate aspartate residue (D2) of LuxO. Phospho-LuxO bound to the  $\sigma^{54}$  protein activates expression of the downstream repressor (X), which, in turn, binds to promoter regions of target genes and shuts off gene expression. In contrast, at high cell densities, when autoinducers accumulate to a given threshold levels in cells, LuxN and LuxP become phosphatases, and dephosphorylation occurs. Dephosphorylated LuxO is inactivated and leads to a cessation of the putative Lux repressor X expression. LuxR, together with RNA polymerase, can bind the promoter regions of target genes to activate the transcription of genes such as the luciferase operon to produce light.

**Factors influencing AI-2 production and activity.** Though *E. coli* and *Salmonella* do not produce AI-1, they do produce AI-2 molecules (Surette and Bassler, 1998). The *luxS* genes in *E. coli*, *Salmonella* and *Campylobacter* have been cloned, and are designated as *luxS<sub>E.c.</sub>* (*ygaG*), *luxS<sub>S.t.</sub>* and *luxS*, respectively. Highly homologous sequences are found among the *luxS* genes of *E. coli*, *Salmonella*, *V. harveyi* and *Campylobacter* (Cloak et al., 2002; Surette et al., 1999). Bassler et al. (1994) constructed the reporter strain *V. harveyi* BB170, which is characteristic of positive sensor LuxP (Sensor 2<sup>+</sup>), but negative sensor LuxN (Sensor 1<sup>-</sup>) on the membrane, for detection of AI-2. If a culture medium sample contains AI-2 molecules, signal transduction will be initiated via the binding of AI-2 molecules to LuxP located on the outer membrane, activating transcription of luciferase genes *luxCDABE* to produce bioluminescence. The intensity of bioluminescence indicates the level of AI-2 activity in the sample. Using the AI-2 bioassay, the production of AI-2 has been shown in laboratory strains of *E. coli* K12, *S. Typhimurium* and

*Campylobacter* spp. as well as several clinical isolates of *E. coli* O157 (Cloak et al., 2002; Surette and Bassler, 1998; Surette et al., 1999). The commonly used laboratory strain *E. coli* DH5 $\alpha$ , however, does not have AI-2 activity. This lack of AI-2 production is due to a frameshift mutation resulting from a 1-bp G-C deletion at base pairs 222 and a T-to-A transversion at 224 in its *ygaG* gene, which results in premature truncation of the LuxS protein in *E. coli* DH5 $\alpha$  (Surette et al., 1999). However, this loss of AI-2 production can be partially, if not completely, restored by introduction of *luxS* genes into *E. coli* DH5 $\alpha$ . Similarly, *S. Typhimurium* *luxS* mutants, unable to produce AI-2 molecules, could be complemented to full AI-2 production by the introduction of *luxS* gene of either *E. coli* or *V. harveyi*. The complementation results suggest that LuxS protein is an essential enzyme in AI-2 synthesis and that AI-2 production is probably affected by other biochemical or physiological factors (Surette et al., 1999).

AI-2 production in *E. coli* and *S. Typhimurium* reaches its maximum at mid- or late-exponential growth phase in the presence of certain preferred carbon sources (Surette et al., 1999). However, AI-2 activity declines in *E. coli* at the stationary phase when cell population is presumably the highest (Surette et al., 1999; Withers and Nordstrom, 1998). This decline in AI-2 activity is not mediated by the regulation of LuxS. In the absence of glucose, LuxS levels remain stable and could even increase slightly when AI-2 levels decline (Hardie et al., 2003). Extracellular AI-2 levels are thus, the net result of AI-2 production and uptake by cells. Since LuxS remains functional to synthesize AI-2 in stationary-phase *E. coli* cells, the decline in AI-2 levels is probably caused by either degradation or uptake of AI-2. It has been reported that in *S. Typhimurium* AI-2 molecules are imported using an ABC transporter, which resembles the ribose uptake

transporter (Taga et al., 2001). In *E. coli*, there exists a similar mechanism, which functions to take up ribose (Blattner et al., 1997; Iida et al., 1984). However, it is still unclear what roles the uptake of AI-2 plays in the survival of cells at stationary phase besides acting as signals for communication. The AI-2 molecule also may be a source of carbon or boron for the cells (Coulthurst et al., 2002; Winzer et al., 2002b). The biochemical events that are possibly involved in the uptake of AI-2 are yet to be identified.

Glucose seems essential in the production of AI-2, but its effect on AI-2 production varies depending on different strains. Surette and Bassler (1998) reported that in laboratory strains of *S. Typhimurium* LT2 and *E. coli* AB1152 AI-2 release into the surrounding milieu depended on the addition of glucose to the growth medium. However, DeLisa et al. (2001b) reported that AI-2 production is detectable in *E. coli* grown in LB medium with and without the presence of glucose. Another study reported that clinical isolates of pathogenic *E. coli* O157:H7 produce AI-2 at 30°C and 37°C in the presence or absence of glucose (Surette et al., 1999). Hardie et al. (2003) also reported that *E. coli* MG1655 produces detectable AI-2 molecules after 6.5 h growth in both the presence and the absence of glucose, but after 24 h growth, AI-2 levels were detectable only in the presence of glucose. Similar effects were observed with other carbon sources, including glycerol, maltose, galactose, ribose and L-arabinose. Among carbon sources such as glucose, mannose, mannitol, fructose, glucosamine, sucrose and maltose, and intermediates in tricarboxylic acid cycle and glycerol, Surette and Bassler (1998) reported that glucose induced the highest level of AI-2 activity, while the intermediates of

tricarboxylic acid cycle and glycerol did not induce significant production of AI-2 activity.

To survive, bacterial cells have to probably adapt to environmental stimuli by inter-bacterial communication. A number of environmental factors have been shown to affect AI-2 production. Fetal bovine serum, serum, and carbonate have been shown to increase AI-2 production (Cloak et al., 2002). Blehert et al. (2003) reported that the addition of serum and carbonate to the growth medium induced maximal AI-2 production in *Streptococcus gordonii*, whereas cells grown in brain heart infusion (BHI) medium alone did not produce AI-2. The physiological bicarbonate concentration in serum and saliva is high enough to stimulate the production of AI-2 and biofilm formation in *S. gordonii*. Surette et al. (1999) reported that exponential growth, low pH, and high osmolarity all increased AI-2 activity in batch culture conditions.

DeLisa et al. (2001b) utilized a chemostat to grow *E. coli* under continuous conditions and observed the effect of different environmental stimuli on the production of AI-2. They challenged the culture at the steady phase with an individual stress factor and measured AI-2 activity by the reporter strain *V. harveyi* BB170. The results showed that increased iron, high osmolarity and decreased culture redox potential with 1g/mL of dithiothreitol (DTT) all exhibited enhancement of AI-2 production within the first 60 min and remained at an elevated level for 3 h before decrease. It was also noted that sodium acetate and pulsed-input of oxygen resulted in transient decreases of AI-2 activity (DeLisa et al., 2001b). However, it has been reported that the addition of acetate to nutrient broth induced the production of AI-2-dependent protein LuxS in another study (Kirkpatrick et al., 2001). DeLisa et al. (2001b) also found that heat shock and ethanol

caused decreased AI-2 activity for about 1 h followed by wave-like change. Stringency resulted from serine hydroxamate repressed AI-2 production for 4 h, while hydrogen peroxide-induced oxidative stress caused the decrease of AI-2 activity for 30 min, followed by a 1.5-fold increase over the next 100 min. The authors of that study hypothesize that the changes in AI-2 production are more likely attributed to a shift in the metabolic activity or the state of the cells caused by each individual stress. In support of this hypothesis, they found that AI-2 production remained at a constant high level in *E. coli* cells grown at 42°C compared to cells grown at 30°C.

AI-2 production is also affected by heterologous gene (foreign gene) expression in genetically modified microorganisms. DeLisa et al. (2001a) reported that plasmid-encoded heterologous gene over-expression of human interleukin-2 (hIL-2), chloramphenicol acetyltransferase (CAT) and viral protein 5 (VP5) in *E. coli* resulted in dramatic decreases in AI-2, while the low-yield proteins of anti-botulinum toxin antibody fragment (bt-Fab), wild-type coat protein of the tobacco mosaic virus (TMVCP) and TMVCP with a proline-to-leucine mutation at position 20 (TMVCP P20L), and highly soluble green fluorescent protein fused to organophosphorus hydrolase (GFPuv/OPH) recombinant protein had no significant effect on AI-2 activity (DeLisa et al., 2001a). This decline of AI-2 activity was not due to inhibition of LuxS protein transcription. In contrast, the transcription of *luxS* gene was significantly increased greater than 3-fold following overexpression of hIL2 (DeLisa et al., 2001b). The magnitude of this AI-2 decline was proportional to the accumulation of heterologous protein in cells. This negative response in AI-2 production caused by the accumulation of foreign proteins and several  $\sigma^{32}$ -mediated stresses such as ethanol stress, heat shock, and amino acid limitation

could overlap at the molecular level (DeLisa et al., 2001b). The mechanism of AI-2 signaling loss due to heterologous gene expression has yet to be studied. Natural plasmids do not appear to have similar negative regulatory effects on AI-2 attenuation as compared to heterologous genes. Bacteria carrying a conjugative plasmid tend to form biofilms which are believed to be mediated by AI-2-based quorum sensing (Ghigo, 2001).

AI-2 production is affected by inorganic substances as well. Recently, borate was reported to have a dramatic effect (a 10-fold increase) on induction of AI-2 in *V. harveyi* (Chen et al., 2002). However, it was not found to have an effect on a LuxS<sup>-</sup> strain that was incapable of synthesizing pro-AI-2 (Chen et al., 2002). It has been proposed that borate drives the spontaneous production of AI-2 from the available pool of pro-AI-2 (Chen et al., 2002).

#### **Role of AI-2 quorum sensing in pathogenicity and antibiotic resistance development.**

AI-2 acts as a signal to regulate gene expression in coordination against host defenses and environmental stresses (Miller and Bassler, 2001). Initially, AI-2 was found to be responsible for regulation of bioluminescence in *V. harveyi* and *V. fischeri* (Miller and Bassler, 2001). Studies to understand the role of AI-2 regulation of gene expression have revealed AI-2 could be involved in global regulatory mechanisms. The finding that that *E. coli* O157 strains exhibit greater AI-2 activity than nonpathogenic *E. coli* strains (Surette et al., 1999), and that pathogenic *S. Typhimurium* 14028 produces significantly more AI-2 than does *S. Typhimurium* LT2 suggest that AI-2 molecules may be related to bacterial pathogenicity. AI-2-based quorum sensing is thought to mediate the transition from a nonpathogenic existence outside a host to a pathogenic existence inside a host. Sperandio et al. (1999) used a transcriptional fusion *lacZ* reporter gene to observe the



effect of AI-2 on the transcription of the Locus of Enterocyte Effacement (LEE) pathogenicity island, a type III secretion system in enterohemorrhagic *E. coli* and enteropathogenic *E. coli*. They found that AI-2-based quorum sensing controls the regulation of the LEE operons. To further screen AI-2-controlled gene transcriptional profiles, Sperandio et al. (2001) and DeLisa et al. (2001b, 2001c) used oligonucleotide microarrays to quantify the transcriptional levels for 4290 open reading frames (ORF) of *E. coli* O157:H7 and *E. coli* strain W3110 in response to AI-2 signals, respectively. The results highlight the fact that AI-2-based quorum sensing is implicated in a global regulation of gene expression in *E. coli*. Of the 4,290 detected genes, 242 genes were either upregulated (154 total genes) or repressed (88 total genes) (more than 2.3-fold in *E. coli* MDAI2 (*luxS*::Tc<sup>r</sup>)) in the presence of AI-2 (DeLisa et al., 2001c). By contrast, 404 of 4290 genes on the array were regulated in *E. coli* O157:H7 (*luxS*::Tc<sup>r</sup>) by at least 5-fold by AI-2 signals (Sperandio et al., 2001). These genes that are regulated by quorum sensing via AI-2 are involved in multiple physiological processes such as cell division, DNA processing, and morphological processes, biofilm formation, cell motility and exopolysaccharide formation (DeLisa et al., 2001c; Sperandio et al., 2001). Subsequent experiments with *lacZ* reporter gene validated that the expression profiles of a two-component system QseBC and a LysR-type regulator QseA in *E. coli* O157:H7 and in *E. coli* K-12 are controlled by AI-2-based quorum sensing (Sperandio et al., 2002a, 2002b). The experiments confirmed that gene *qseB* encodes the response regulator, and QseC protein is the sensor kinase in response to AI-2-based quorum sensing. The QseBC system is involved in the regulation of flagella and motility genes. The mutant *qseC* exhibits reduced motility in comparison with the wild type and complemented strains.

The expression of flagellin significantly decreases in the *qseC* mutant (Sperandio et al., 2002a). By contrast, LyR-type regulator QseA is responsible for regulation of virulence gene expression. Mutation of the *qseA* gene causes a defect in the type III secretion system. QseA is an activator of *ler*, a gene associated with attachment and effacement (AE) lesion in *E. coli* O157:H7 (Sperandio et al., 2002b). However, QseA controls the regulation of LEE at the distal LEE1 promoter in extension primer analysis. Recently, Sperandio et al. (2003) reported that a novel LuxS-dependent autoinducer (termed as AI-3) is produced by *E. coli* O157:H7. This autoinducer may mediate cross-talk between bacteria and host cells. The mammalian hormone epinephrine (Epi) could function as AI-3, activating transcription of the type III secretion system and flagella genes. These findings suggest that *E. coli* O157:H7 might modulate virulence gene expression at different stages of infection and/or different locations of the gastrointestinal tract by the sensing of bacterial quorum sensing molecules and mammal signals.

AI-2-controlled phenotype(s) may vary dependent on species. Sperandio et al. (1999) reported that two distinct phenotypes are characteristic of *E. coli* O157:H7 (*luxS::Tc<sup>r</sup>*) AI-2 mutants. One has a faster growth rate, and the other has decreased motility in the mutants relative to the wild-type strain. However, no differences in growth rate were observed in *Campylobacter jejuni* and *Helicobacter pylori luxS* mutants in comparison to the wild-type strains (Elvers and Park, 2002; Joyce et al., 2000), and *Streptococcus pyogenes* AI-2 mutants grew slower than the wild type (Lyon et al., 2001).

AI-2 inhibited initiation of DNA replication, and this inhibition was found to be temporary in bacteria (Withers and Nordstrom, 1998). Cells in which DNA replication were blocked could be restored to full functionality after approximately 30 min of

exposure to supernatant containing AI-2 molecules. It was hypothesized that this transient inhibition was caused by insufficient AI-2 molecular concentration in culture (Withers and Nordstrom, 1998). The functions of AI-2 in physiological processes have been screened extensively in other bacteria as well as in *E. coli*.

Taga et al. (2001, 2003) reported that AI-2 molecules control the expression of a previously uncharacterized operon (*lsrACDBFGE*) that encodes an ABC transporter apparatus, an ATP binding cassette. The transporter, in turn, functions in the uptake of AI-2 from the extracellular environment in *S. Typhimurium*. It has been reported that motility in *Campylobacter jejuni* is related to AI-2-based quorum sensing (Elvers and Park, 2002). Decreased toxin production was observed in *Clostridium perfringens luxS* mutants at mid-exponential growth phase (Ohtani et al., 2002), although no significant difference was obtained in toxin mRNA levels between the mutant and the wild type at stationary growth phase. Derzelle et al. (2002) showed that AI-2-based quorum sensing is related to antibiotic production by *Photobacterium luminescens*. In *Shigella flexneri*, the operons, *ipa*, *mxi* and *spa*, encoding type III secretion systems, are enhanced by AI-2-based quorum sensing. However, virulence gene expression was not affected in AI-2 mutants (Day and Maurelli, 2001). Duan et al. (2003) reported that virulence genes in *P. aeruginosa* are up-regulated by host microflora through interspecies communication based on AI-2 signals.

The accumulation of AI-2 molecules in the exponential phase has been proposed to serve as a signal to lead *E. coli* cells to enter the stationary phase. Cells in the stationary phase show increased resistance to a number of environmental stresses, such as high osmolarity, oxidative agents and high temperature (Lazazzera, 2000; Zambrano and

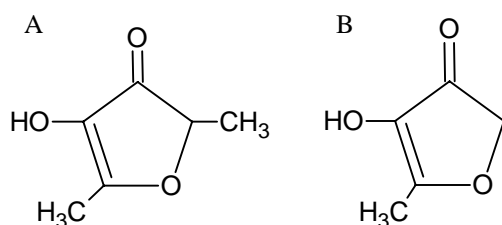
Kolter, 1996). A study shows that swarming populations of *S. Typhimurium* exhibited multiple mechanisms of antibiotic resistance (Kim and Surette, 2003). Recently, protein SidA, a regulator of AI-2 molecules, was reported to positively mediate the multidrug efflux pump AcrAB (Rahmati et al., 2002). Overexpression of SdiA increased antibiotic resistance levels. By contrast, SdiA mutants exhibit hypersensitive to antibiotics (Rahmati et al., 2002). SdiA was found to be up-regulated following hHL-2 expression and in the presence of AI-2 molecules in *E. coli* (DeLisa et al., 2001a, 2001b, 2001c). DeLisa et al. (2001c) reported that the *MarB* (multiple antibiotic resistance protein) expression increased 3.1-fold when *E. coli* was exposed to AI-2 molecules. Transposase that is responsible for transposition is up-regulated by AI-2 as well (DeLisa et al., 2001b, 2001c).

It has been reported that oligopeptides induce competence for genetic transformation by the uptake of free DNA from the surrounding medium and incorporation of that DNA into the genome through homologous recombination in Gram-positive bacteria (Alloing et al., 1996, 1998; Havarstein et al., 1995). Conjugal transfer of Ti plasmid from *Agrobacterium* donors to bacterial recipients is controlled by AI-1-based quorum sensing (Piper et al., 1993; Oger and Farrand, 2001, 2002). Recently, a novel uncharacterized airborne signal is thought to induce *E. coli* to become tolerant to the antibiotic ampicillin (Heal and Parsons, 2002). These findings are noteworthy but it remains to be determined whether AI-2-based quorum sensing mediates the development of antibiotic resistance in bacteria.

**Autoinducer activity in plants and foods.** Several plants have been found to secrete AI-1 mimic compounds, which act as either AI-1-like molecules, signal blockers, signal degrading enzymes or inhibitors of AI-1-like producing enzymes (Fray, 2002; Givskov et al., 1996; Teplitski et al., 2000). Teplitski et al. (2000) reported that pea seedlings, soybean and tomato plant were found to contain several separable activities that mimicked AI-1 signals in well-characterized bacterial reporter strains, activating AI-1-controlled behaviors in some strains while inhibiting such behaviors in others. The secretion of AI-1 mimic activities by legume *Medicago truncatula* was found to change dependent on developmental age of seedlings (Gao et al., 2003). Although the active compounds from plants have not been chemically characterized, many plant extracts in organic solvents stimulate AI-1-controlled response in bacteria. In contrast, halogenated furanones of red alga share considerable structural similarity to AI-1, but they competitively inhibit AI-1 activity and help the alga in controlling bacterial colonization and fouling of its surfaces in a marine environment (Manefield et al., 1999, 2002; Ren et al., 2001).

An AI-2-like active compound of DMHF (2, 5-dimethyl-4-hydroxy-3(2H)-furanone) (**Fig. 2.6**) was reported to be present in fruits such as tomatoes, strawberries and pineapples, as well as in yeast fermentation products and in the products of Maillard reactions (Slaughter, 1999; Winzer et al., 2002b). Bauer and Robinson (2002) found that rice and *M. truncatula* seedlings produce compounds that mimic AI-2 signals. More recently, the unicellular soil-freshwater alga *Chlamydomonas reinhardtii* was reported to secrete compounds that mimic AI-2-dependent quorum sensing to modulate gene expression (Teplitski et al., 2004). These findings indicate that quorum sensing molecule-

mimic compounds are produced by plants to affect specific pathogens or spoilage bacteria. Interestingly, Mathesius et al. (2003) reported that *M. truncatula* secretes compounds that inhibit AI-2-dependent quorum sensing in bacteria as well.



**Fig. 2.6.** Structures of AI-2 analogs. (A) DMHF (2, 5-dimethyl-4-hydroxy-3(2H)-furanone) and (B) its analog MHF (4-hydroxy-5-methyl-3(2H)-furanone) (Modified from Winzer et al., 2002b).

It was also noted that AI-2 activity was maximal for *E. coli* O157:H7, *S.*

*Typhimurium* and *Campylobacter* spp., 3 h postinoculation in both milk and chicken broth at 4°C and by 24 h postinoculation at 25 or 37°C (Cloak et al., 2002). This evidence suggests AI-2 production by bacterial cells on different foods could have some ramifications in terms of food safety and quality. However, the mechanisms of AI-2 induction by food matrix are still unknown.

# CHAPTER III

## AUTOINDUCER 2-BASED RESPONSE INDUCES TETRACYCLINE TOLERANCE IN *ESCHERICHIA COLI* UNDER SUB- THERAPEUTIC EXPOSURE

### OVERVIEW

Autoinducer 2 (AI-2)-based quorum sensing has recently gained attention, because it is thought to be utilized for cell-to-cell communication for regulation of gene expression and induction of bacteria entry to stationary phase in response to environmental stimuli. The objective of this study was to understand the relationships existing between exposure to sub-therapeutic tetracycline, AI-2 activity and tetracycline tolerance development in *Escherichia coli*. Laboratory studies using two tetracycline-resistant and 1 tetracycline-sensitive *E. coli* isolates were performed. Though all three isolates produced AI-2, they had different patterns of AI-2 activities in response to sub-therapeutic tetracycline exposure. In the presence of tetracycline, the Tet<sup>s</sup> *E. coli* strain continued to have increasing AI-2 activity even after 20 hours of exposure to the antibiotic (2 µg/mL). Results indicate that AI-2 actually enhances the ability of the Tet<sup>s</sup> *E. coli* strain to survive sub-therapeutic tetracycline (10 µg/mL) stress. About 87% of the Tet<sup>s</sup> *E. coli* strain survived 4 hours of exposure to chlortetracycline in LB plus 80% cell-free supernatant (AI-2<sup>+</sup>). After 20 hours of exposure, the 69% survival rate of the Tet<sup>s</sup> strain was still significantly higher (P<0.05) than in the control treatments. There was, however, no difference between the survival of the Tet<sup>s</sup> strain when exposed to only 20% cell-free supernatant (AI-2<sup>+</sup>). The enhanced AI-2 activity can protect the cells from

tetracycline stress and lead to the development of tetracycline-tolerant sub-populations which can serve as a selective advantage.

## INTRODUCTION

Bacterial populations in response to cell density and environmental stimuli have been known to produce, secrete and respond to low molecular weight molecules termed autoinducers (Surette and Bassler, 1998; Withers et al., 2001). This currently termed as quorum sensing process is shown to help in coordinated regulation of gene expression (Sperandio et al., 2001; Taga and Bassler, 2003; Xavier and Bassler, 2003). Generally, Gram-negative bacteria employ acylated-homoserine lactones as autoinducers, while Gram-positive bacteria use oligopeptides for intra- and inter-species communications (Bassler et al., 1993; Camara et al., 2002; Miller and Bassler, 2001). In addition to acylated homoserine lactone (AI-1), another autoinducer molecule that has recently been characterized as furanosyl borate diester (AI-2) is widely produced and utilized by a large number of Gram-negative and Gram-positive bacteria (Bassler, 2002; Chen et al., 2002). In each AI-2-producing bacterium, AI-2 synthesis requires LuxS protein, the sequence of which is highly conserved among different bacteria such as *E. coli*, *Salmonella* Typhimurium, *Vibrio harveyi*, *Vibrio Cholerae*, and *Campylobacter* spp. (Cloak et al., 2002; Surette et al., 1999; Xavier and Bassler, 2003).

Given its universal presence, AI-2 is considered as a universal signal molecule for inter- and intra-species bacterial communications (Xavier and Bassler, 2003). Multiple physiological processes in *E. coli* are linked to AI-2. Studies have shown that the extra-cellular accumulation of AI-2 influences the expression of genes that control DNA



replication, cell division, virulence, biofilm formation, as well as other physiological processes (DeLisa et al., 2001c; Ren et al., 2001; Sperandio et al., 2001). In *E. coli*, the AI-2 concentration reaches maximal levels when cells are in the mid-exponential growth phase in the presence of certain carbon sources. However, *E. coli* does not produce AI-1 (Surette and Bassler, 1998). Cell-free supernatants of media from which *E. coli* was grown has stimulated the expression of the *rpoS* gene, which encodes the alternate sigma factor  $\sigma^S$  involved in stationary phase, induce the cell to enter the stationary phase, providing tolerance to high osmolarity conditions, oxidative agents and resistance to elevated temperatures (Lazazzera, 2000; McDougald et al., 2003; Mulvey et al., 1990; Sitnikov et al., 1996). Previous studies have also shown that AI-2 production in *E. coli* is influenced by stimuli such as nutrient concentrations, pH, redox potential and temperature (DeLisa et al., 2001b).

Antimicrobials such as the tetracyclines are widely used not only in clinical medicine for treatment of bacterial infections but also in sub-therapeutic concentrations as animal growth promoters (Schnappinger and Hillen, 1996; Teuber, 2001). There is a widespread concern that such use of antimicrobials can accelerate the emergence of antibiotic resistance in enteric bacteria (Roberts, 1996; Roe and Pillai, 2003). In our laboratory, we are interested in identifying the reservoirs of antibiotic resistance determinants and the factors that permit an antibiotic-sensitive strain to become tolerant or resistant to antibiotics (Roe et al., 2003a; Roe et al., 2003b). The raised question is whether quorum sensing-based bacterial communication is involved in the development of antibiotic resistance. The *underlying hypothesis* was that exposure to sub-therapeutic concentrations of tetracycline stimulates the production of the universal AI-2 in *E. coli*,

which promotes tetracycline tolerance development in tetracycline-sensitive *E. coli* strains. *E. coli* isolates from poultry and irrigation water samples were used to test the hypothesis.

## MATERIALS AND METHODS

**Bacterial strains and media.** Three *E. coli* isolates (Isolate 1, 12 and 5) were used in this study. Isolates 1 and 12 were isolated from poultry and were resistant to tetracycline defined as Tet<sup>r</sup> *E. coli* strains (MIC $\geq$ 128  $\mu$ g/mL and MIC $\geq$ 32  $\mu$ g/mL, respectively).

Isolate 1 harbors the *tet*(B) gene and was confirmed by PCR. In contrast, Isolate 12 was a resistant by a yet-to-be determined mechanism to tetracyclines. This isolate was negative for *tet*(A), *tet*(B), *tet*(C), *tet*(D), *tet*(E), *tet*(G), *tet*(K), *tet*(L), *tet*(M), *tet*(O), *tet*(Q),

*tet*A(P) *tet*(S) and *tet*(X) by PCR. Isolate # 5 isolated from irrigation water was sensitive to tetracycline defined as Tet<sup>s</sup> *E. coli* strain (MIC $<$ 1  $\mu$ g/mL). This strain was also sensitive to other antibiotics such as ampicillin, streptomycin, gentamycin, kanamycin, chloramphenicol, trimethoprim/sulfamethoxazole, ciprofloxacin and ceftriaxone.

Reporter strain *Vibrio harveyi* BB170 (*luxN*::Tn5, sensor 1<sup>-</sup> sensor 2<sup>+</sup>) that only senses AI-2 molecule, and AI-2-producing *V. harveyi* BB120 (AI-1<sup>+</sup> AI-2<sup>+</sup>) and BB152 (*luxL*::Tn5, AI-1<sup>-</sup> AI-2<sup>+</sup>) were used for the AI-2 bioassay, and were kindly provided by Dr. Bassler. The autoinducer bioassay (AB) medium was prepared as previously described (Bassler et al., 1994).

**Cell-free supernatant (CFS) preparation.** Overnight cultures of the *E. coli* strains were inoculated into individual tubes containing 10 mL of Lauria-Bertani broth (LB; Difco, Detroit, MI) supplemented with 0.5% glucose, and challenged with and without 2  $\mu$ g/mL

of tetracycline (Sigma Chemical Co., St. Louis, MO). Preliminary studies indicated that 1-4  $\mu\text{g}/\text{mL}$  of tetracycline did not have any negative effects on the induction of luminescence in the reporter strain *V. harveyi* BB170 by exogenous AI-2 molecules. Samples of each culture were removed 2, 8, and 20 h (postinoculation) for preparation of CFS. The CFS was prepared by centrifuging ( $8000 \times \text{rpm}$  for 5 min at  $4^\circ\text{C}$ ) the samples followed by filtration through 0.2- $\mu\text{m}$ -pore-size syringe filters (Corning, New York, NY). CFS containing AI-2 as positive controls were prepared from overnight culture of *V. harveyi* BB152 and BB120 at  $30^\circ\text{C}$  as described above for *E. coli*. Viable cell counts were performed using spread plate methods on LB agar. The CFS was stored at  $-20^\circ\text{C}$  until AI-2 activity bioassay was performed.

**AI-2 activity bioassay.** The assay was performed as described by Surette and Bassler (1998). An overnight culture of *V. harveyi* BB170 was diluted (1:5,000) with fresh AB media. Ninety microliters of this diluted culture was mixed with 10  $\mu\text{L}$  of the CFS sample in a 96-well micro-isoplate (Perkin Elmer life science Inc., Boston, MA). Ten microliters of *V. harveyi* BB120 and BB152 CFS were used as positive controls, and 10  $\mu\text{L}$  of AB media were used as negative controls. The plates were shake-incubated (100 rpm) at  $30^\circ\text{C}$  in a Lab-Line Orbital Shaker Incubator (Melrose Park, IL). Luminescence was measured every 30 min using a Perkin Elmer Wallac Victor 2 luminometer in the luminescence mode. AI-2 activity was expressed as *relative AI-2 activity*, calculated as the ratio of luminescence of a sample and the control (negative) sample. To dissociate the AI-2 activity with cell density, relative AI-2 activity was normalized by 1 log unit of *E. coli* viable cells.

**Influence of AI-2 concentrations on tetracycline tolerance development.** Overnight cultures of the Tet<sup>s</sup> *E. coli* (Isolate 5) were transferred to fresh LB broth, and grown to log phase at 37°C. Portions of the culture were diluted (1:50,000) in either LB, LB containing 20% (20 mL of CFS plus 80 mL of LB) or 80% of CFS. The heated CFS (100°C for 10 min to inactivate AI-2 activity) samples and LB alone served as AI-2 negative controls (Surette and Bassler, 1998). The samples were initially treated at 37°C for 30 min.

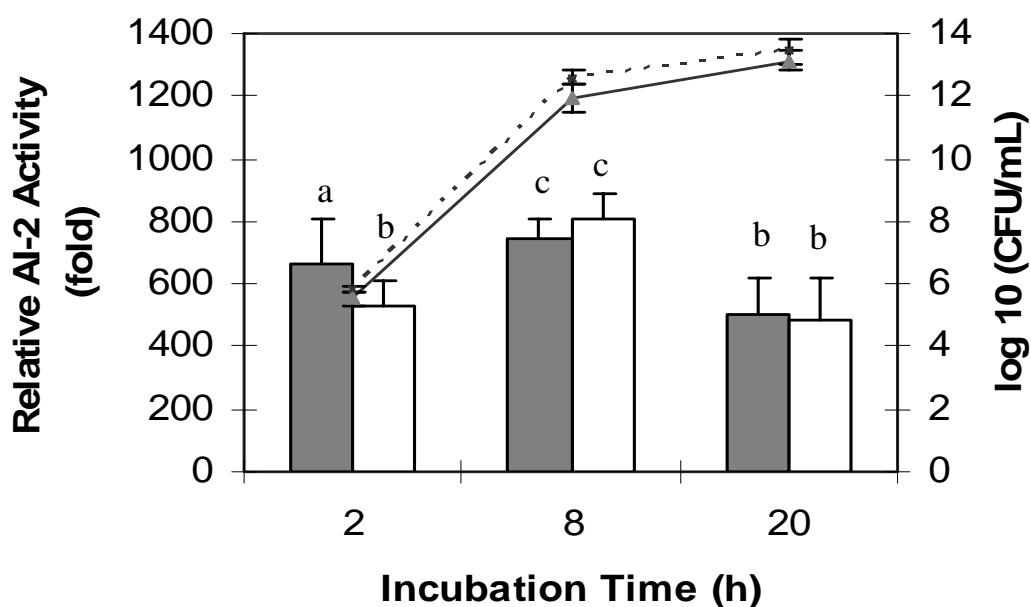
Subsequently, aliquots of the samples were removed and plated on LB agar for obtaining bacterial counts. Once these samples were removed, chlortetracycline (Sigma Chemical Co.) in a final concentration of 10 µg/mL (greater than 10× the MIC of the sensitive strain) was added to each tube. The cultures were then incubated at 37°C. Samples were removed at 4- and 20-h post-challenge for enumerating viable bacterial cells on LB agar.

**Statistical analyses.** All experiments were performed in triplicate, and each CFS sample was assayed for AI-2 activity in triplicate using *V. harveyi* BB170. Bacterial population was expressed as log<sub>10</sub> CFU/mL. The data were analyzed using the General Linear Model (GLM) of SAS (version 8.0, SAS Institute Inc., Cary, NC). A p value of 0.05 was used as a critical value for statistical significance.

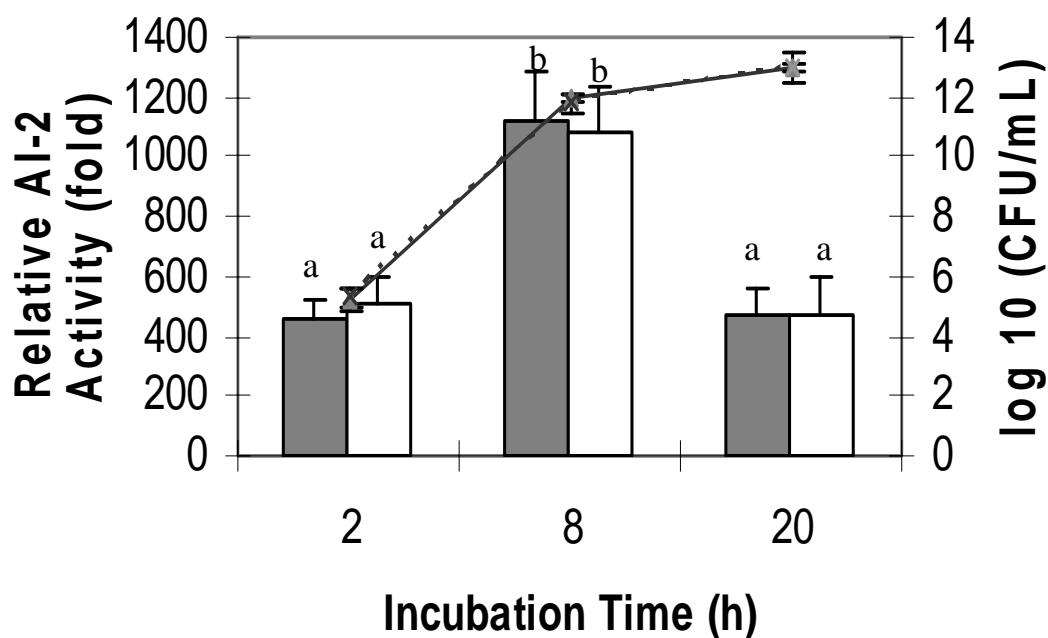
## RESULTS

**Bacterial multiplication and response of AI-2 activity in Tet<sup>f</sup> and Tet<sup>s</sup> *E. coli* to sub-therapeutic tetracycline exposure.** Figures 3.1, 3.2 and 3.3 depict relative AI-2 activity in the three *E. coli* strains when exposed to 2 µg/mL of tetracycline as a function of viable cell counts. In Tet<sup>f</sup> *E. coli* Isolate 1 and 12 (**Fig. 3.1 and Fig. 3.2**), there was no significant difference in cell numbers in relation to tetracycline exposure. In Isolate 5 of

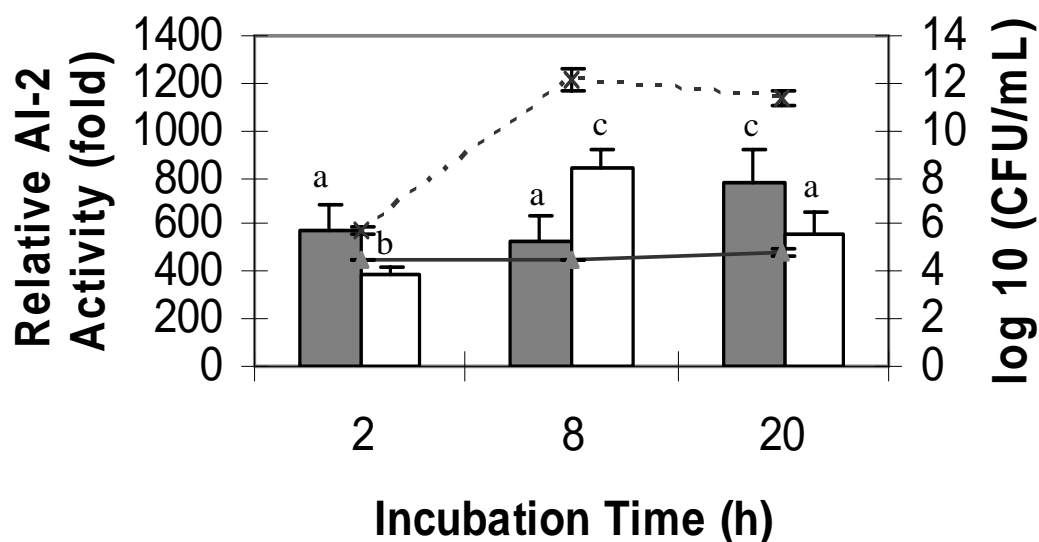
Tet<sup>s</sup> *E. coli* strain, however, there was a difference in the viable cell counts depending on the presence or absence of tetracycline (**Fig. 3.3**). As expected, cell numbers remained constant in the presence of 2 µg/mL of tetracycline in this tetracycline-sensitive isolate during incubation.



**Fig. 3.1.** Relative AI-2 activity and growth curve of tetracycline-resistant *E. coli* Isolate 1. The lines represent the cell numbers ( $\log_{10}$  CFU/mL) while the histogram represents relative AI-2 activity. Solid lines and dashed lines represent cell numbers in the presence and absence of tetracycline (2 µg/mL) exposure respectively. Solid histogram bars and empty histogram bars represent relative AI-2 activity in the presence and absence of tetracycline (2 µg/mL) exposure. The error bars denote standard deviation of the means from three replicates each assayed in triplicate using *V. harveyi* BB170 (n=9).



**Fig. 3.2.** Relative AI-2 activity and growth curve of tetracycline-resistant *E. coli* Isolate 12. The lines represent the cell numbers ( $\log_{10}$  CFU/mL) while the histogram represents relative AI-2 activity. Solid lines and dashed lines represent cell numbers in the presence and absence of tetracycline ( $2 \mu\text{g/mL}$ ) exposure respectively. Solid histogram bars and empty histogram bars represent relative AI-2 activity in the presence and absence of tetracycline ( $2 \mu\text{g/mL}$ ) exposure. The error bars denote standard deviation of the means from three replicates each assayed in triplicate using *V. harveyi* BB170 ( $n=9$ ).



**Fig. 3.3.** Relative AI-2 activity and growth curve of tetracycline-sensitive *E. coli* Isolate 5. The lines represent the cell numbers ( $\log_{10}$  CFU/mL) while the histogram represents relative AI-2 activity. Solid lines and dashed lines represent cell numbers in the presence and absence of tetracycline ( $2 \mu\text{g/mL}$ ) exposure respectively. Solid histogram bars and empty histogram bars represent relative AI-2 activity in the presence and absence of tetracycline ( $2 \mu\text{g/mL}$ ) exposure. The error bars denote standard deviation of the means from three replicates each assayed in triplicate using *V. harveyi* BB170 ( $n=9$ ).

In all three isolates, maximal AI-2 activity is seen around 8 hours in coincidence with the peak of cell numbers in the absence of tetracycline exposure. However, in the presence of tetracycline, it is evident that the Tet<sup>s</sup> *E. coli* strain of Isolate 5 continued to have increasing AI-2 activity even at 20 hours of exposure to the antibiotic (**Fig. 3.3**).

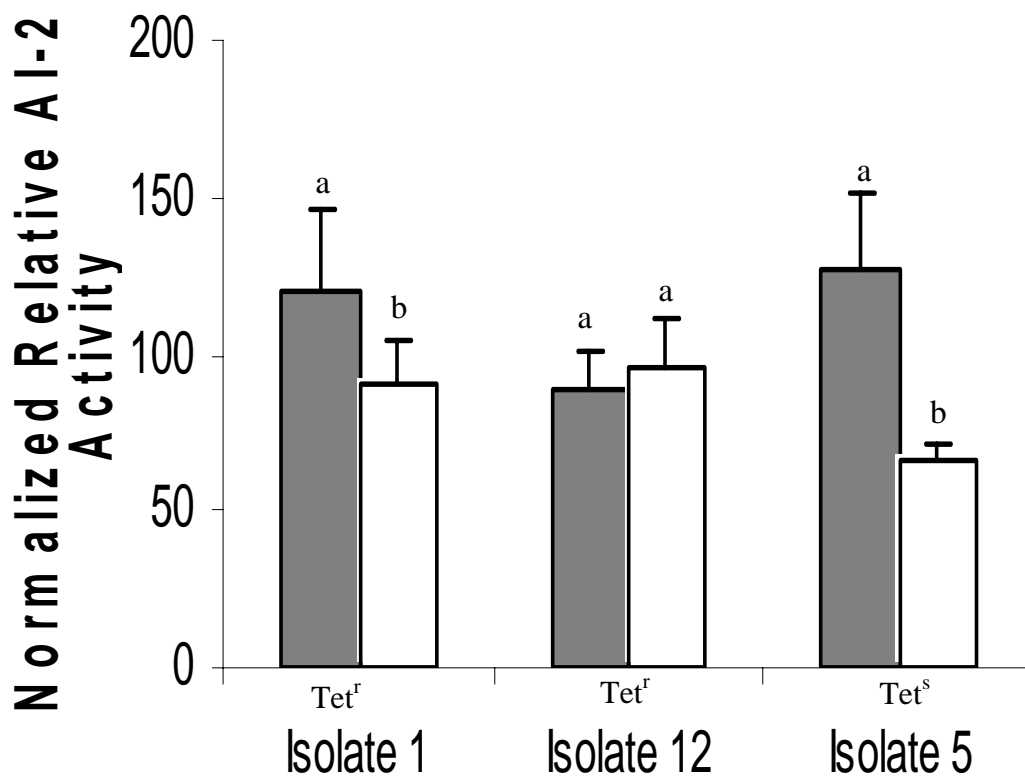
When the AI-2 activities among the 3 isolates are compared to one another using

normalized relative AI-2 activity as the index, it is evident that the sensitive strain (Isolate 5) had significantly different response pattern of AI-2 activity from the other strains after 2 h, 8 h, and 20 h of sub-therapeutic tetracycline exposure (**Figs. 3.4, 3.5 and 3.6**). The Tet<sup>s</sup> *E. coli* (Isolate 5) had significantly increased AI-2 activity under sub-therapeutic tetracycline exposure by 20 hours.

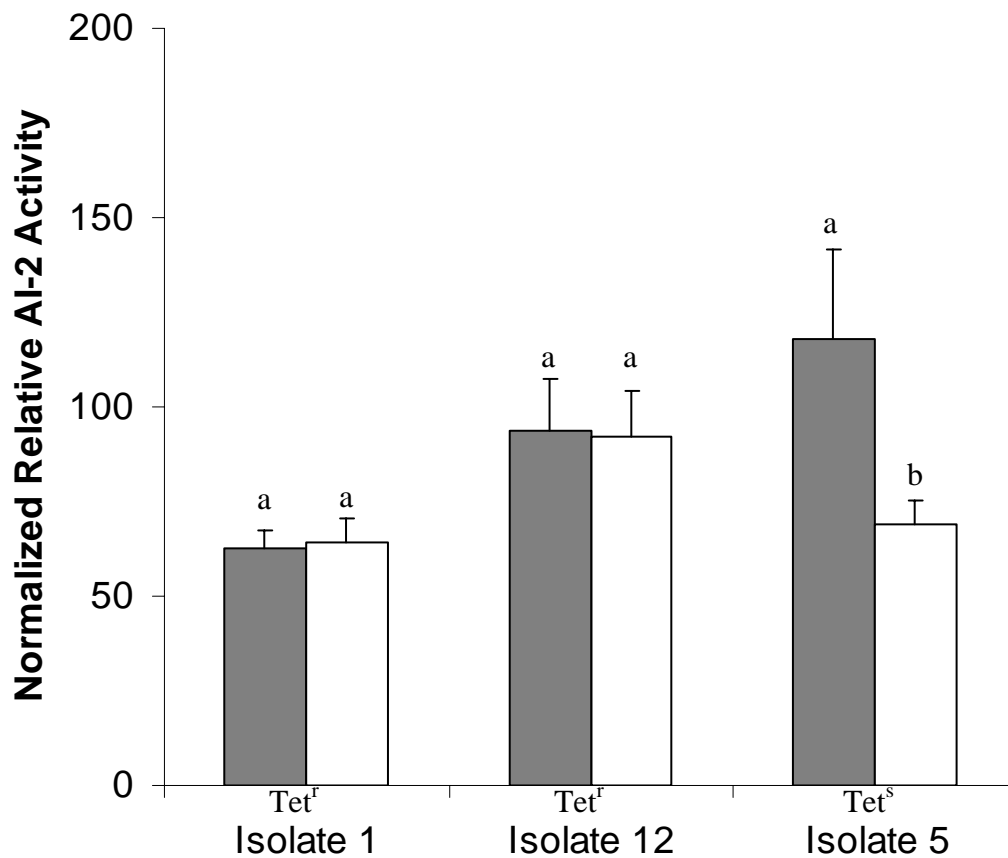
There are differences in the AI-2 activity response patterns among tetracycline resistant strains exposed to sub-therapeutic tetracycline. This is evident in the resistant isolate (Isolate 1) where the normalized relative AI-2 activity was greater in the presence than in the absence of tetracycline exposure at 2 hours. In contrast there was no such difference in Isolate 12 (**Fig. 3.4**).

**AI-2 induced tetracycline tolerance development in tetracycline-sensitive strain.** To test the hypothesis that AI-2 induces tetracycline tolerance in Tet<sup>s</sup> *E. coli*, we treated Tet<sup>s</sup> *E. coli* (Isolate 5) with CFS (AI-2<sup>+</sup>) for 30 min prior to the addition of 10 µg/mL of chlortetracycline (**Table 3.1**). About 87% of Tet<sup>s</sup> *E. coli* cells survived 4-h exposure to chlortetracycline when previously treated with LB plus 80% CFS. This survival rate was significantly higher ( $P < 0.05$ ) than the 62% and 58% survival rates that were observed when exposed to the negative controls (heat-inactivated CFS and LB medium). When isolates were transferred to tetracycline-amended (8 µg/mL) LB agar, there was no colony formation (data not included). After 20-h exposure to chlortetracycline, the survival rate of 69% observed in the CFS treatment group was still significantly higher ( $P < 0.05$ ) than that of 50% and 51% observed in the negative controls. However, there was no significant difference ( $P > 0.05$ ) in the survival rate of Tet<sup>s</sup> *E. coli* among three treatments when the tetracycline-sensitive strains were exposed to only 20% CFS.

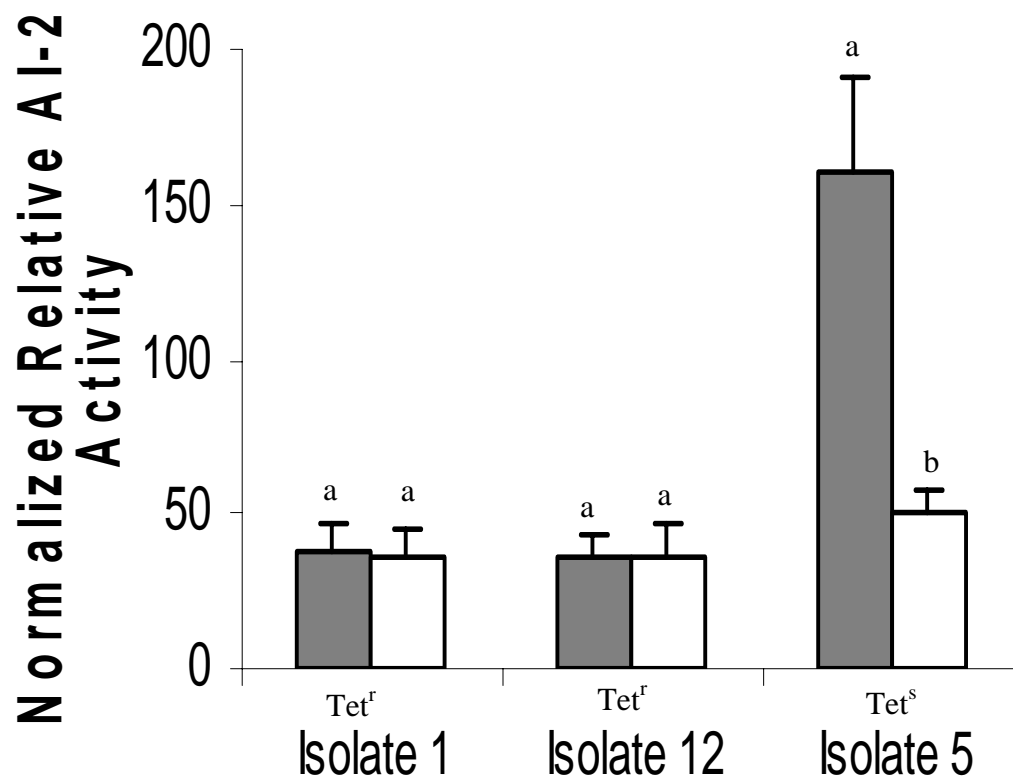




**Fig. 3.4.** Normalized relative AI-2 activity in tetracycline-resistant and sensitive *E. coli* strains at 2 h in the presence and absence of tetracycline exposure. Solid histogram bars represent normalized relative AI-2 activity with tetracycline exposure, and open histogram bars represent normalized relative AI-2 activity without tetracycline exposure. The results represent means and standard deviation from triplicates (n=9). The same isolate with different letter indicate statistically significant difference ( $p < 0.05$ ).



**Fig. 3.5.** Normalized relative AI-2 activity in tetracycline-resistant and sensitive *E. coli* strains at 8 h in the presence and absence of tetracycline exposure. Solid histogram bars represent normalized relative AI-2 activity with tetracycline exposure, and open histogram bars represent normalized relative AI-2 activity without tetracycline exposure. The results represent means and standard deviation from triplicates (n=9). The same isolate with different letter indicate statistically significant difference ( $p < 0.05$ ).



**Fig. 3.6.** Normalized relative AI-2 activity in tetracycline-resistant and sensitive *E. coli* strains at 20 h in the presence and absence of tetracycline exposure. Solid histogram bars represent normalized relative AI-2 activity with tetracycline exposure, and open histogram bars represent normalized relative AI-2 activity without tetracycline exposure. The results represent means and standard deviation from triplicates (n=9). The same isolate with different letter indicate statistically significant difference ( $p < 0.05$ ).

**Table 3.1.** Influence of AI-2 in the survival and tetracycline tolerance of tetracycline-sensitive *E. coli* Isolate 5

Tetracycline Exposure Time (h)	Treatment	No. of Viable Cells $\log_{10}$ (CFU/mL) <sup>†</sup>	log reduction of viable cells $\log_{10}$ (CFU/mL) <sup>*</sup>
0	80% of CFS	$3.8 \pm 0.14^a$	-
	80% of heated CFS	$4.1 \pm 0.14^a$	-
	LB media	$4.2 \pm 0.42^a$	-
	20% of CFS	$4.1 \pm 0.09^a$	-
	20% of heated CFS	$4.1 \pm 0.09^a$	-
	LB media	$3.7 \pm 0.37^a$	-
4	80% of CFS	$3.3 \pm 0.11$	$0.5 \pm 0.11^b$
	80% of heated CFS	$2.6 \pm 0.24$	$1.5 \pm 0.24^c$
	LB media	$2.4 \pm 0.39$	$1.8 \pm 0.39^c$
	20% of CFS	$2.5 \pm 0.20$	$1.6 \pm 0.20^d$
	20% of heated CFS	$2.5 \pm 0.10$	$1.6 \pm 0.10^d$
	LB media	$2.5 \pm 0.26$	$1.2 \pm 0.26^d$
20	80% of CFS	$2.6 \pm 0.39$	$1.2 \pm 0.39^e$
	80% of heated CFS	$2.1 \pm 0.29$	$2.0 \pm 0.29^f$
	LB media	$2.1 \pm 0.22$	$2.0 \pm 0.22^f$
	20% of CFS	$2.8 \pm 0.21$	$1.4 \pm 0.21^g$
	20% of heated CFS	$2.5 \pm 0.40$	$1.6 \pm 0.40^g$
	LB media	$2.1 \pm 0.15$	$1.6 \pm 0.15^g$

<sup>†</sup> \*The same tetracycline exposure time with different superscripts indicate statistically significant differences ( $p < 0.05$ ).

## DISCUSSION

Given that Isolate 1 and 12 are intrinsically resistant to tetracycline, it is not surprising that there were no significant differences in their cell numbers over 20 hours irrespective of the presence or absence of tetracycline (2 µg/mL). As expected, Isolate 5 which was sensitive to tetracycline did not multiply in the presence of the antibiotic stress (**Fig. 3.3**). Previous studies have shown that laboratory *E. coli* strains and some clinic *E. coli* O157:H7 isolates produce AI-2 but not AI-1 molecules (Cloak et al., 2002; Hardie et al., 2003; Sperandio et al., 2001; Surette and Bassler, 1998). AI-2 activity in proper proportion to cell density which was observed in the tetracycline-resistant strains (Isolate 1 and 12) in this study agrees with other reports that AI-2 levels reach their maximal levels at the mid-log phase and decline as the cells reach stationary phase (Hardie et al., 2003; Surette and Bassler, 1998). The increase of AI-2 activity was observed in Isolate 1 that contains the *tet(B)* gene increased by 2 h following exposure of the *E. coli* cell to sub-therapeutic tetracycline concentrations (**Fig. 3.1**), at which *tet(B)* gene is activated. This observation, however, does not agree with the report that AI-2 activity decreased in *E. coli* following over-expression of several heterologous plasmid-encoded genes (DeLisa et al., 2001a).

These results, which demonstrate AI-2 activity in the absence of cell multiplication, are novel. To our knowledge, there have been no other such published reports. The phenomenon was observed in the Tet<sup>s</sup> *E. coli* (Isolate 5) (**Fig. 3.3**). The Tet<sup>s</sup> strain exhibited increasing AI-2 activity over 20 hours in the presence of tetracycline as compared to the resistant strains which showed the typical bell-shaped curve of AI-2 activity. When the AI-2 activity was normalized, it was evident that the Tet<sup>s</sup> *E. coli* strain

had almost three times the amount of AI-2 activity in the presence of sub-therapeutic concentrations of the antibiotic as compared to the absence of the antibiotic or in comparison to the resistant strains at 20 h.

S-adenosylmethionine (SAM) is a substrate of the synthesis of AI-2 and serves as a methyl donor in the biosynthesis and modification of DNA, RNA and certain proteins. The synthesis of AI-2 from SAM is catalyzed by three enzymes working sequentially namely, methyltransferases, Pfs nucleosidase and LuxS (Chen et al., 2002; Schauder et al., 2001). SAM provides the methyl group by the action of methyltransferases, and is converted to S-adenosylhomocysteine (SAH), a toxic intermediate which needs to be rapidly hydrolyzed to non-toxic S-ribosylhomocysteine (SRH) and adenine by Pfs nucleosidase. Protein LuxS subsequently cleaves SRH to 4, 5-dihydroxy 2, 3-pentanedione (DPD) followed by random cyclization and combination with boron to form AI-2 (Chen et al., 2002; Schauder et al., 2001). The increase of SAM promotes AI-2 production, and its synthesis is energy dependent. Tetracycline is a bacteriostatic agent which inhibits bacterial protein synthesis by preventing the binding of aminoacyl-tRNA to ribosome RNA molecules (Roberts, 1996). In the case that protein synthesis is blocked in a Tet<sup>s</sup> strain, ATP molecules are built up in a cell and in combination with methionine forms SAM (McNab and Lamont, 2003; Schauder et al., 2001). The increased AI-2 activity in Tet<sup>s</sup> *E. coli* cells exposed to sub-therapeutic antibiotic stress is likely a result of the shift in intercellular metabolism and detoxification.

The data in **Table 3.1** signify the importance of AI-2-based bacterial communication in the survival of Tet<sup>s</sup> *E. coli* cells in the presence of sub-therapeutic tetracycline concentrations. We thought AI-2 molecules induced Tet<sup>s</sup> *E. coli* tolerance to

tetracycline, because when selected colonies were tested for resistance to 8  $\mu\text{g/mL}$  of tetracycline, there was no indication that the cells had indeed become resistant. This result is in agreement with previous studies that showed that cell-free supernatants induced bacteria resistance to stresses (McDougald et al., 2003; Mulvey et al., 1990; Sitnikov et al., 1996). We are presently unsure which particular gene(s) are influenced by AI-2 to endow these tolerant cells survivability under these conditions. Beeston and Surette (2002) reported that exogenous AI-2 molecules had no effect on the transcription of *luxS* and *pfs* genes. However, it has also been reported that the expression of a number of genes is influenced when the concentration of extracellular AI-2 reaches a particular threshold. In *E. coli* hundreds of genes have been shown to be positively regulated, and hundreds of genes are also negatively regulated by AI-2 molecules (DeLisa et al., 2001c; Sperandio et al., 2001). The upregulated expression of *rpoS* gene induces the cells to enter the stationary phase, and results in resistance to factors such as osmolarity, oxidative agents and high temperatures (Hengge-Aronis, 1999; Loewen et al., 1998; Wei et al., 2001; Zambrano and Kolter, 1996). We are currently in the process of identifying the *E. coli* genes that are AI-2 directed and are involved in the tolerance to selected antibiotics.

In conclusion, these results suggest that natural isolates of *E. coli* can produce AI-2 in the presence or absence of sub-therapeutic antibiotic stress. More importantly, these results provide strong evidence that subjecting a Tet<sup>s</sup> *E. coli* strain to sub-therapeutic tetracycline exposure will induce the increased activity of the universal AI-2. The enhanced AI-2 activity can protect the cells from tetracycline stresses and lead to the development of tetracycline-tolerant cells, which provides enough recipient cells for

genetic transfer. We are currently attempting to understand the relationship(s) between AI-2 activity and transfer of antibiotic resistance determinants in enteric bacteria.



## CHAPTER IV

### **AUTOINDUCER 2 (AI-2) PRODUCTION IN ENTERIC BACTERIA IN RESPONSE TO SUB-THERAPEUTIC ANTIBIOTIC EXPOSURE**

#### **OVERVIEW**

The autoinducer molecule, AI-2 is considered to be a universal signal for regulating a wide variety of physiological processes in bacterial cells by regulating gene expression patterns. Studies were conducted to observe how *E. coli* cells would respond to sub-therapeutic concentrations under continuous culture (chemostat) conditions, to observe AI-2 activity by the probiotic chicken microbial consortium (CF3) under *in vitro* conditions simulating a chicken cecum, and to observe the *in-vivo* AI-2 activity within a chicken cecum as a function of exposure to sub-therapeutic levels of chlortetracycline, vancomycin and tylosin. When the *E. coli* cells were in a steady state (under continuous culture conditions) at 24 h, AI-2 activity remained stable albeit at only a 20-fold increase over baseline conditions. When the *E. coli* cells under steady state conditions were exposed to tetracycline at sub-therapeutic concentrations (2 µg/mL), the results indicate increasing AI-2 activity in response to increasing levels of tetracycline. The probiotic CF3 culture, however, did not exhibit any AI-2 activity in Viande Levure (VL) medium in the presence or absence of sub-therapeutic levels of tetracycline. *In vivo* studies conducted in the cecum of poultry chicks demonstrate that though AI-2 activity increased initially in the presence of vancomycin, there was no significant increase in AI-2 activity in the presence of tetracycline or tylosin. Overall, these results suggest that detectable levels of AI-2 activity are not evident within the chicken cecum based on the response

observed in the *in vitro* studies conducted with the probiotic CF3 culture, or *in vivo* within the chicken cecum. The absence of detectable AI-2 activity, and the vulnerability of chicks to enteric bacterial pathogen colonization is worthy of further studies.

## INTRODUCTION

There is an expanding interest in understanding the role of bacterial quorum sensing as it relates to bacterial responses to “stresses” such as therapeutic and sub-therapeutic antibiotic exposure. Previous studies have shown that autoinducer molecules oligopeptides, AI-1 and AI-2 and more recently AI-3 are involved in bacterial quorum sensing (Taga and Bassler, 2003; Xavier and Bassler, 2003; Sperandio et al., 2003). A wide variety of physiological processes, such as sporulation in *Bacillus subtilis* (Grossman, 1995; Koetje et al., 2003; Pottathil and Lazazzera, 2003), competence for genetic transformation in *Streptococcus pneumoniae* (Alloing et al., 1998; Steinmoen et al., 2002), virulence expression in *Staphylococcus aureus* (Lina et al., 1998), *Pseudomonas aeruginosa* (Jude et al., 2003; Hentzer et al., 2003) and *E. coli* O157 (Sperandio et al., 2001, 2003), Ti plasmid conjugation in *Agrobacterium tumefaciens* (Oger and Farrand, 2002; Pappas and Winans, 2003) and the production of antibiotic in *Erwinia caratovora* (Dong et al., 2001; Byers, et al., 2002), are regulated by quorum sensing in response to cell density and environmental stimuli. The autoinducer molecule, AI-2 is considered a universal signal for regulation of gene expression in bacteria.

It has been reported that AI-2 production is influenced by a number of environmental factors such as temperature, pH, oxygen, glucose, carbonate ions and osmolarity (DeLisa et al., 2001b; Blehert et al., 2003). Antibiotics are widely used in

clinical medicine for infectious treatment and in agriculture for animal growth promoters at sub-therapeutic levels (Huges and Heritage, 2002; Roberts, 1996). Tetracyclines are a family of broad-spectrum antibiotics and are extensively used in human medicine and in animal husbandry primarily because of its efficacy and also because it is relatively inexpensive (Schnappinger and Hillen, 1996; Teuber, 2001). However, there are concerns that the widespread use of this class of antibiotics have led to the emergence of tetracycline resistant bacterial populations (Levy, 1986; Roberts, 1996; Blake et al., 2003a, 2003b; Bahl et al., 2004). Bacterial resistance to tetracycline is mediated primarily via mutations in 16s rDNA sequence (Trieber and Taylor, 2002), ribosomal protection by resistant genes encoding proteins, efflux pumps, and enzymatic inactivation of tetracycline (Taylor and Chau, 1996; Roberts, 1996). Previous studies in our laboratory have shown that AI-2 activity increases in tetracycline-sensitive *E. coli* when exposed to sub-therapeutic concentrations of tetracycline. We have observed in batch culture studies that increasing AI-2 activity in tetracycline-sensitive *E. coli* induces these cells to become tolerant to sub-therapeutic levels tetracycline. The objective of these studies were a) to observe how *E. coli* cells would respond to sub-therapeutic concentrations under continuous culture conditions; b) to observe AI-2 production by a representative chicken cecum microbial population under continuous culture conditions; and c) to observe the *in-vivo* AI-2 production within a chicken cecum as a function of exposure to sub-therapeutic levels of chlortetracycline, vancomycin and tylosin.

## MATERIALS AND METHODS

### **Bacterial strains and chicken cecum microbial populations.**

***E. coli* strain.** The tetracycline-sensitive *E. coli* strain (Isolate 5) was used in the initial continuous culture studies. This strain was isolated from the environment and is a prolific AI-2 producer (Lu et al., 2003).

***Vibrio harveyi.*** *Vibrio harveyi* BB170 (*luxN*::Tn5 sensor 1<sup>-</sup> sensor 2<sup>+</sup>), BB120 (AI-1<sup>+</sup> AI-2<sup>+</sup>) and BB152 (*luxL*::Tn5 AI-1<sup>-</sup> AI-2<sup>+</sup>) were used for measuring autoinducer AI-2 activity and were kindly provided by B. L. Bassler (Princeton University, NJ).

**Preempt<sup>®</sup> CF3 culture.** The chicken-derived Preempt<sup>®</sup> CF3 culture was originally propagated from cecal content collected from an adult broiler chicken and maintained through CF culture as described by Hume et al. (1997). The microbial populations present in the Preempt<sup>®</sup> CF3 are made up of approximately 29 different strains and have been listed previously (Corrier et al., 1995).

**Culture media.** Luria-Bertani (LB; Difco, Detroit, MI) medium was supplemented with 0.5% glucose. Viande Levure (VL) broth contained tryptone (10 g liter<sup>-1</sup>, Difco), yeast extract (5 g liter<sup>-1</sup>, Difco), beef extract (2.4 g liter<sup>-1</sup>, Difco), NaCl (5 g liter<sup>-1</sup>, EM Science, Gibbstown, NJ), L-cysteine-HCl (0.6 g liter<sup>-1</sup>, Sigma Chemical Co., St. Louis, MO) and glucose (2.5 g liter<sup>-1</sup>, Sigma Chemical Co.). Autoinducer (AB) medium has been described in detail elsewhere (Bassler, et al., 1994; Lu et al., 2004).

**Continuous culture experiments.** Continuous culture (chemostat) experiments were conducted using overnight LB cultures of *E. coli* Isolate 5 and the chicken-derived Preempt<sup>®</sup> CF3 cultures maintained in VL broth. These cultures were inoculated into a temperature-regulated microfermentor (also named as chemostat; New Brunswick

Scientific co. Inc., Edison, NJ) containing 750 mL of LB (1:100, vol:vol) with or without glucose, or VL broth. The cultures were maintained at 39°C with agitation (200-rpm), and sparged with O<sub>2</sub>-free nitrogen to maintain anaerobic conditions. The cultures were maintained at a constant rate of 0.52 mL/min of VL or LB medium by an automatic pump, which was equal to a dilution rate of 0.0416 h<sup>-1</sup>. From 6<sup>th</sup> day onwards, sub-therapeutic levels of chlortetracycline (2 and 4 µg/mL) were added to the continuous culture once each day for 5 consecutive days. Experiments involving the *E. coli* Isolate 5 involved the use of 2 µg/mL, while the chicken-derived Preempt<sup>®</sup> CF3 cultures were exposed to 4 µg/mL.

**Cell density measurement.** Three 1-mL samples of the chemostat cultures were removed at 5-min, 1-hour, 2-hour, 4-hour, 8-hour, and 24-hour post-tetracycline exposure for measuring cell density using OD<sub>600</sub> measurements (The samples were also used for determining AI-2 activity). OD<sub>600</sub> measurements were made using 200 µL of the sampled cultures in 96-well microtiter plate (Perkin Elmer Life Science Inc., Boston, MA) with a computer-based spectrometer (SpectraMax 340PC, Molecular Devices, Sunnyvale, CA).

**Autoinducer AI-2 activity.** The cell-free supernatants (CFS) of the chemostat samples were used to measure AI-2 activity. The CFS samples were prepared by centrifuging 0.8-mL of the sample at 8000 × rpm for 5 min at room temperature. The supernatant was filtered using 0.2-µm-pore size syringe filter (Corning, New York, NY) and stored at -20°C prior to analysis. *Vibrio harveyi* BB120 and BB152 cell-free supernatants were prepared as described as reported previously (Surette and Bassler, 1998). The AI-2 activity in the CFS was evaluated using the *V. harveyi* reporter strain described previously by Surette and Bassler (1998). Briefly, an overnight culture of *V. harveyi*

reporter strain BB170 was diluted (1:5,000) with fresh AB media. Ninety microliters of the reporter strain dilution and 10  $\mu$ L of each cell-free supernatant sample were mixed in an individual well of a 96-well micro-isoplate (Perkin Elmer Life Science Inc., Boston, MA). Ten microliters of *V. harveyi* BB120 and BB152 CFS were used as positive controls, and 10  $\mu$ L of AB media were used as negative. The plates were incubated at 30°C with shaking. Luminescence was measured every 30 min with a computer-controlled luminometer (Perkin Elmer Wallac Victor 2). AI-2 activity was expressed as relative AI-2 activity, which was the ratio of luminescence unit of a sample and the control (negative) sample, and normalized relative AI-2 activity was calculated as relative AI-2 activity divided by OD<sub>600</sub>.

***In vivo* AI-2 activity within poultry chicks in response to antibiotic administration.**

One-day chicks were randomly grouped into 4 groups and placed in individual pens in separate rooms. The chicks were challenged (by gavage inoculation) with 0.5 mL of vancomycin-resistant *Enterococcus* (roughly 10<sup>7</sup> CFU/mL). Three groups were fed with starter feed containing sub-therapeutic levels (50 g/ton) of vancomycin, chlortetracycline and tylosin, respectively, for first 14 days, and then followed by grower feed containing sub-therapeutic level of the same antibiotic for the same group. Chicks were provided with feed and water *ad libitum*. Weekly, the ceca of 5 chicks were removed after cervical dislocation and the cecal contents were collected. The cecal contents were suspended in Butterfield's buffer (to achieve a 10-fold dilution). The samples were treated such that CFS samples were prepared from the cecal contents as mentioned above. The CFS was then evaluated for AI-2 activity as mentioned above.

**Data analysis.** The AI-2 activity data that are reported are based on the mean from three independent samples assayed using *V. harveyi* BB170. All chemostat experiments were run in duplicate. The relative AI-2 activity was expressed as the ratio of luminescence unit of a sample and the negative control in fold, and normalized relative AI-2 activity was calculated as relative AI-2 activity divided by OD<sub>600</sub>. The data were processed using General Linear Model (GLM) in SAS software for mean difference test (version 8.0, SAS Institute Inc., Cary, NC). A p value of 0.05 was used as a critical value for statistical significance.

## RESULTS

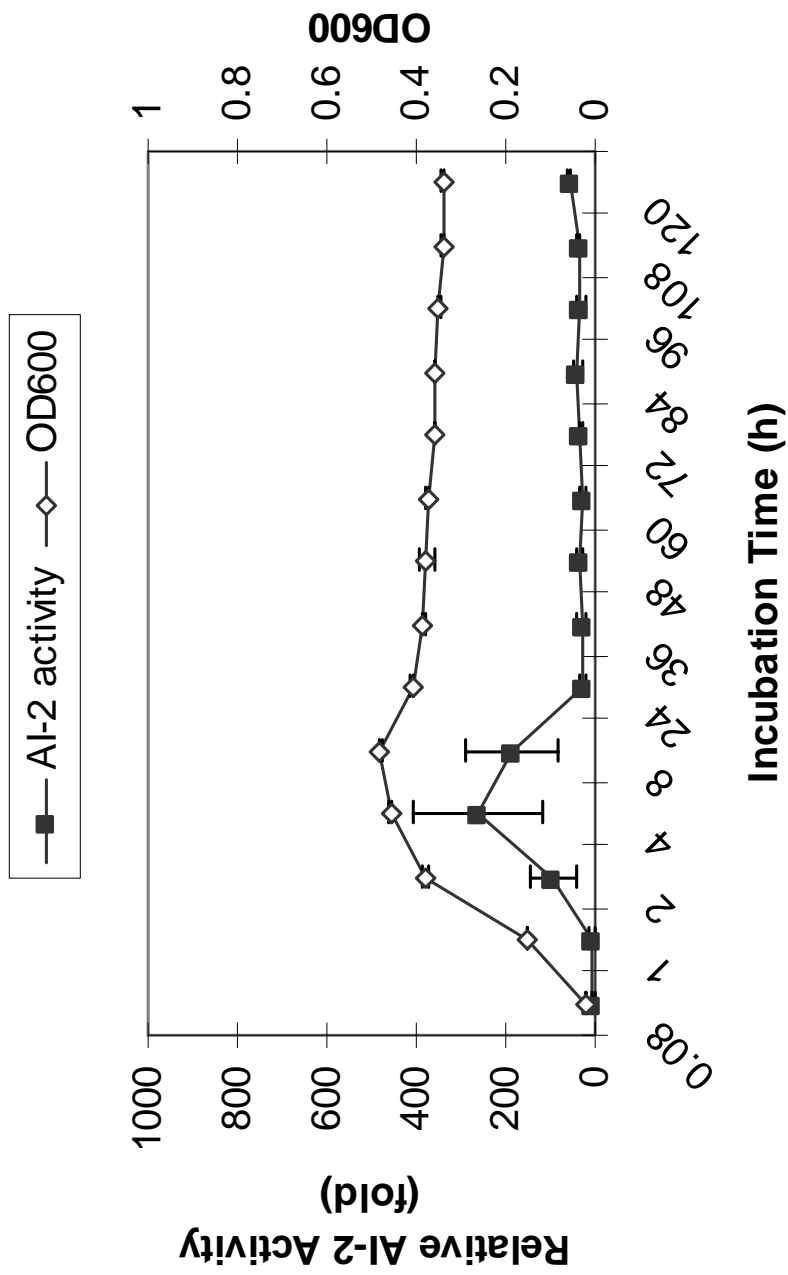
**AI-2 activity in *E. coli* maintained under continuous culture conditions.** The *E. coli* Isolate 5 initially seeded into LB broth at a 1% concentration (v/v) was maintained in a chemostat at 39°C (under anaerobic conditions). The AI-2 activity increased within the first 4 hours and declined by 8 hours. The increase in AI-2 activity initially appears to correspond to the increase in cell density, based on the OD<sub>600</sub> measurements (**Fig. 4.1**). When the cells were in a steady phase (under continuous culture conditions) at 24 h, AI-2 molecule production/activity remained stable albeit at only a 20-fold increase over baseline conditions.

Since glucose has been previously shown to affect AI-2 molecule production in *E. coli*, chemostat experiments were performed in which *E. coli* Isolate 5 cells were maintained under continuous culture conditions in LB medium containing 0.5% of glucose (**Fig. 4.2**). The results were similar to that observed when LB without glucose was employed. The AI-2 activity increased within 4 h of seeding, however, the activity

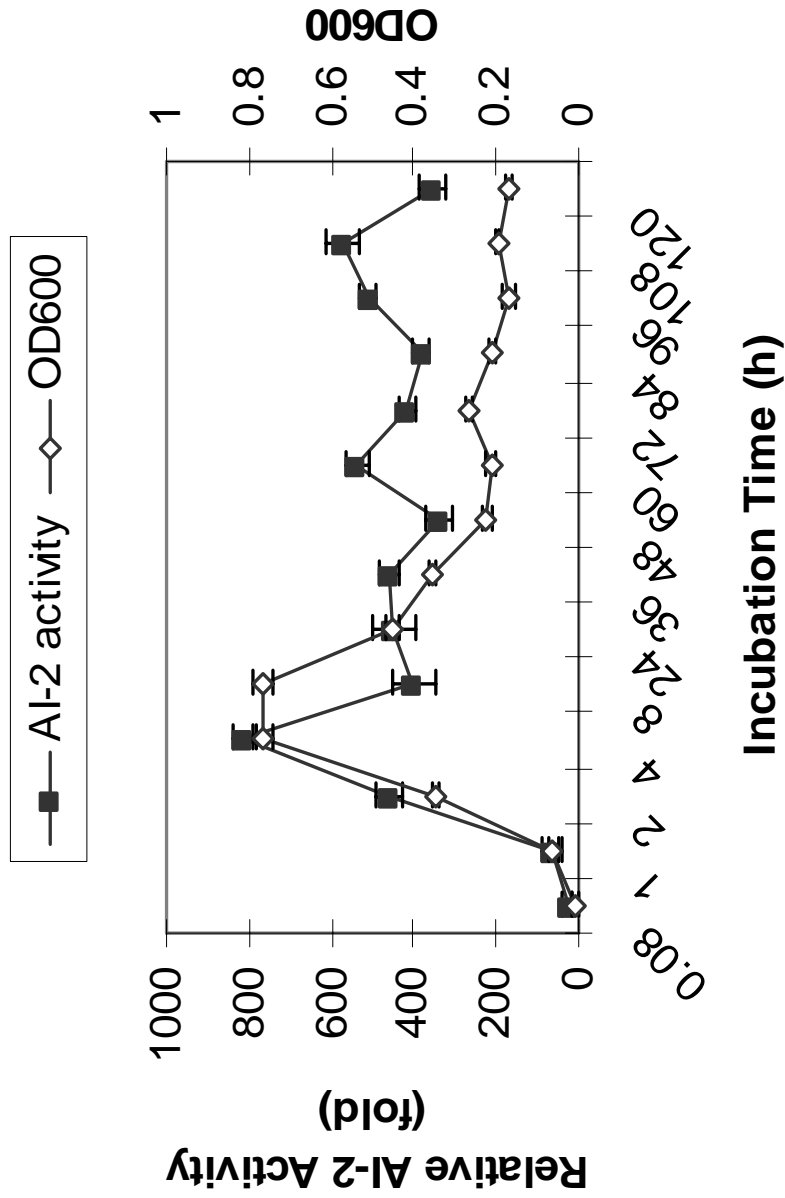
decreased by 8 h post-inoculation. The culture apparently did not enter steady state conditions until 48 h. This is in contrast to that observed under “no-glucose” conditions. There was variation in the AI-2 activity from 8 hours to 120 hours post-inoculation. Even though the cell numbers were lower in the “plus-glucose” conditions than the “no-glucose” steady state conditions, AI-2 activity was higher in the presence of glucose than when maintained in the absence of glucose.

**AI-2 activity in response to sub-therapeutic chlortetracycline exposure in chemostat (continuous culture) maintained *E. coli*.** The effect of exposing the *E. coli* Isolate 5 maintained under steady-state (continuous culture) conditions to sub-therapeutic levels of tetracycline on AI-2 activity is shown in **Fig. 4.3**. Chlortetracycline (sodium salt) was added once per day in a final concentration of 2 µg/mL for consecutive 5 days. AI-2 activity and OD<sub>600</sub> was monitored at 0.083-, 2-, 4-, 8- and 24-h post-feed of chlortetracycline. The values obtained from the 24-hour samples were used as baseline. In the absence of glucose, AI-2 activity declined rapidly at 5-min, however, increased within 24-h (**Fig. 4.3**). The cell density, however, decreased slightly. A similar pattern of AI-2 activity was observed when the tetracycline sensitive isolate was maintained under steady state conditions in the presence of glucose (**Fig. 4.4**). The AI-2 activity was, however, at a higher overall level in the presence of glucose than in the absence of glucose. When the AI-2 activity was normalized based on cell counts (to eliminate the effect of cell density on the level of AI-2 activity), the results indicate increasing AI-2 activity when exposed to sub-therapeutic levels of tetracycline (**Fig. 4.5, Fig. 4.6**).

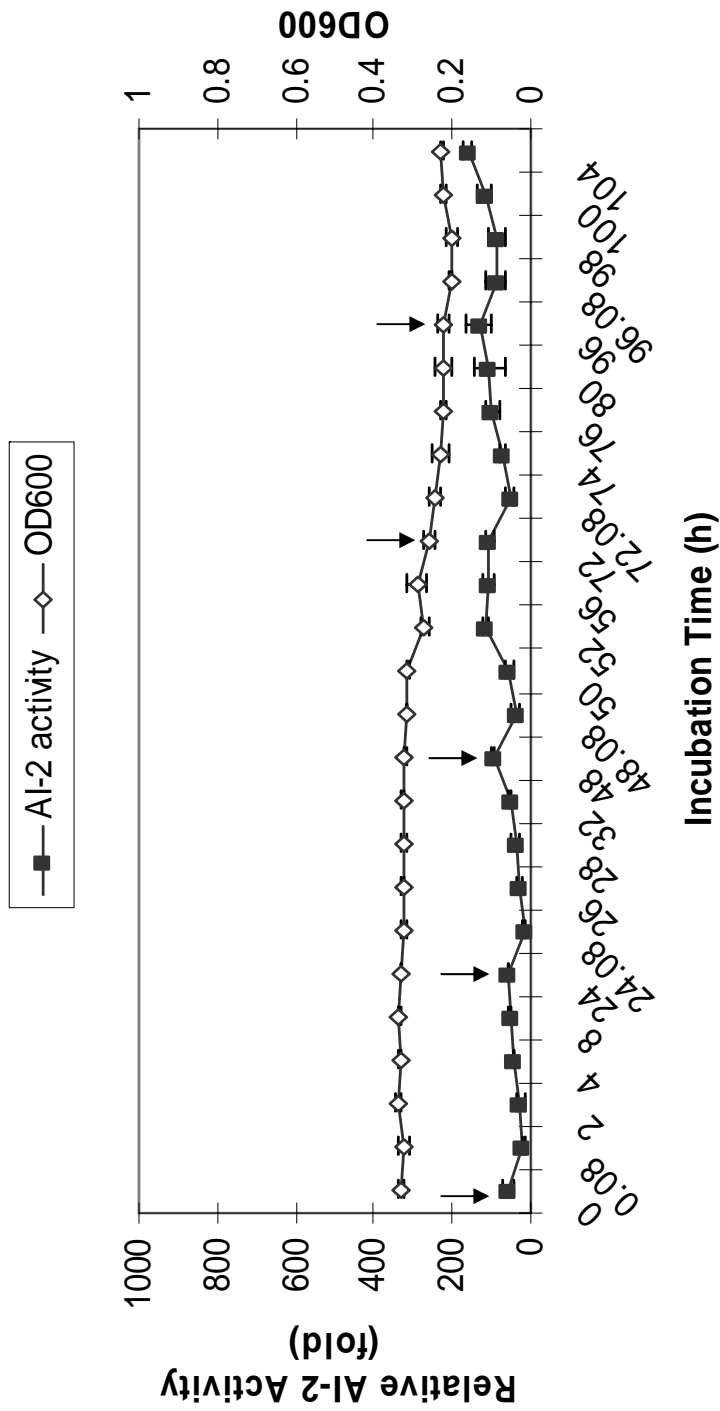




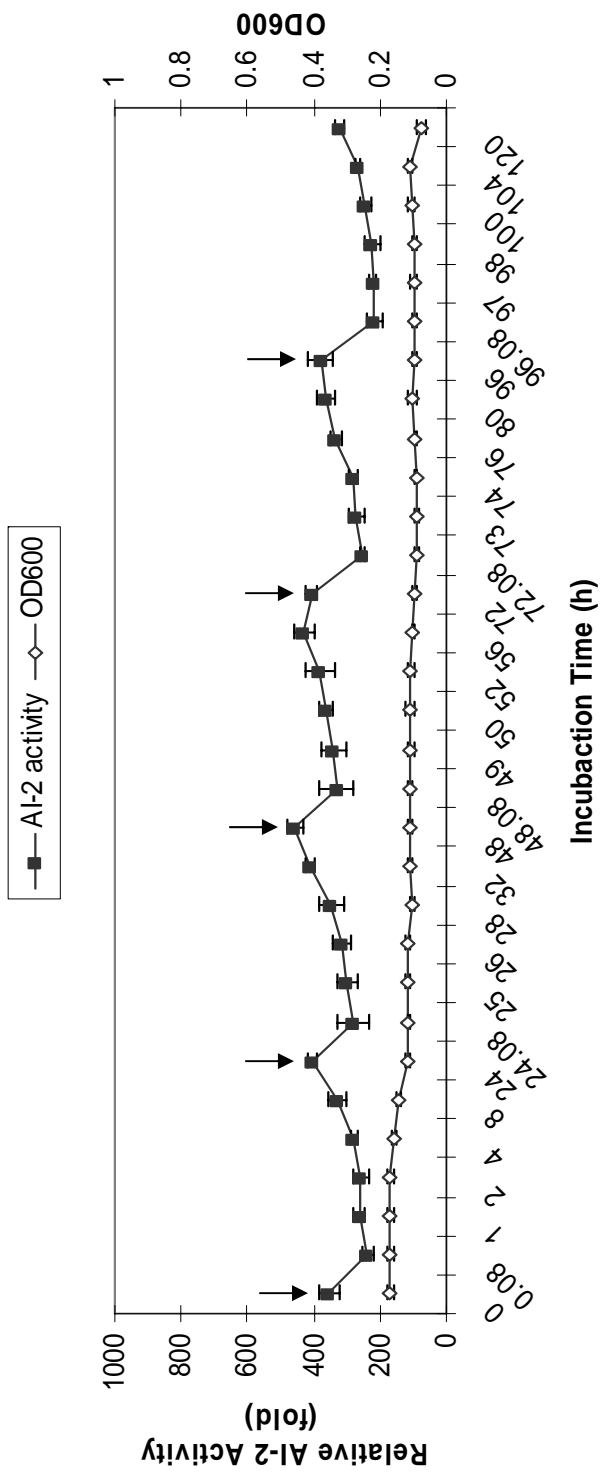
**Fig. 4.1.** AI-2 activity and OD<sub>600</sub> in chemostat-cultivated *E. coli* Isolate 5 in LB broth under anaerobic conditions. Each point represents an average of 6 replicates, and error bar is standard deviation.



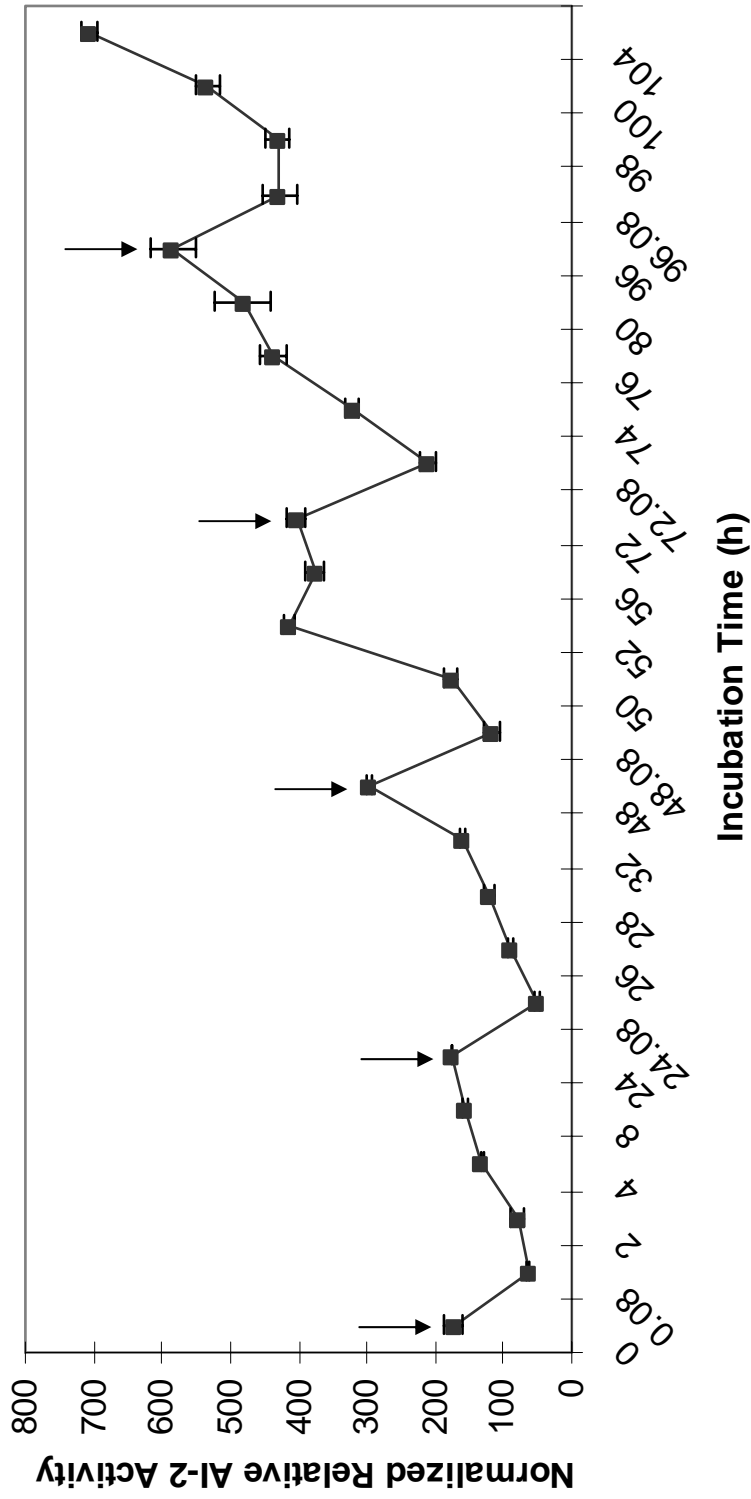
**Fig. 4.2.** Al-2 activity and OD<sub>600</sub> in chemostat-cultivated *E. coli* Isolate 5 in LB broth plus 0.5% glucose under anaerobic conditions. Each point represents an average of 6 replicates, and error bar is standard deviation.



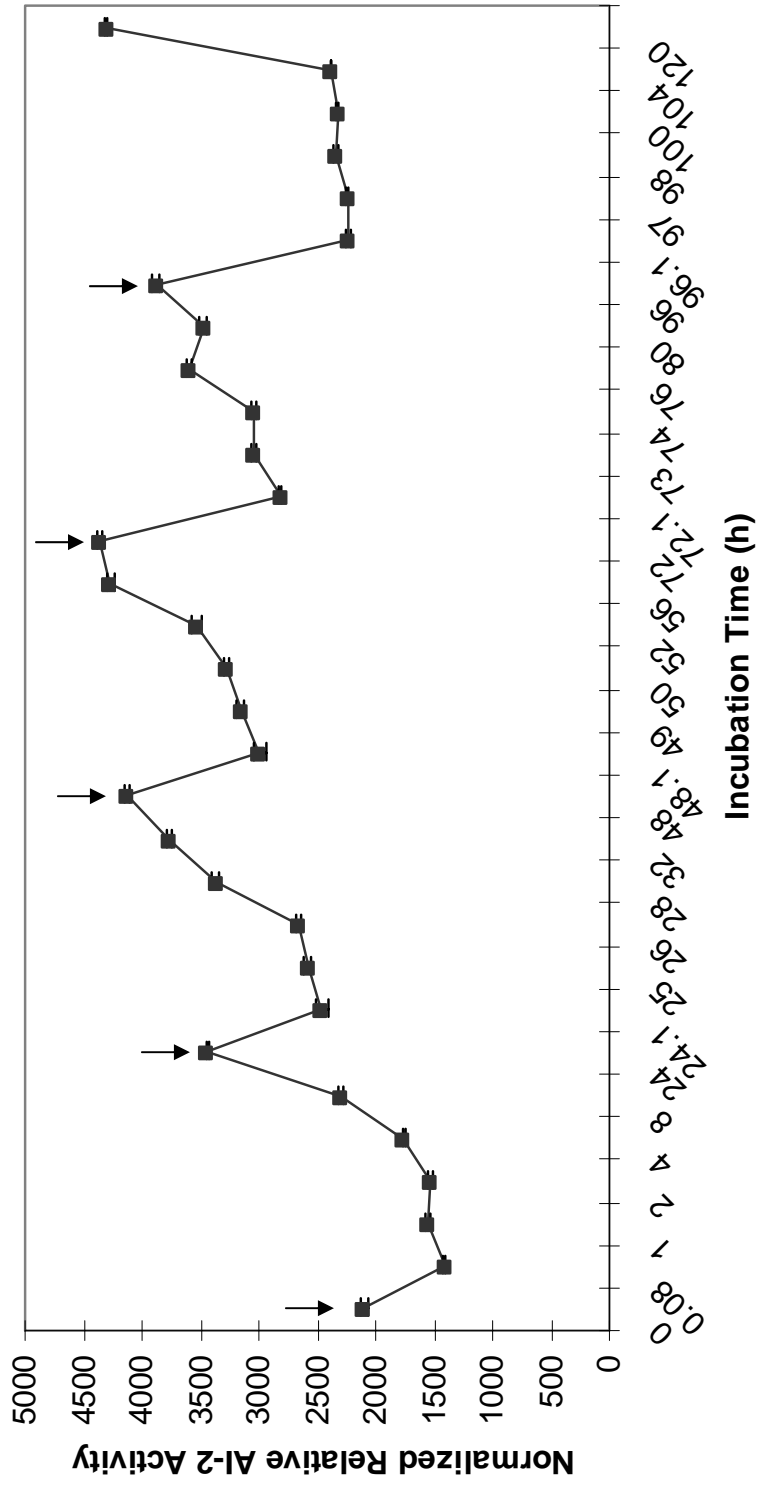
**Fig. 4.3.** AI-2 activity and OD<sub>600</sub> in chemostat-cultivated *E. coli* Isolate 5 exposed to sub-therapeutic chlorotetracycline (2 µg/mL) in LB broth. Chlorotetracycline is added once (arrow indicated) each day for 5 consecutive days in culture growth rate (0.0416 h<sup>-1</sup>) of steady-phase tetracycline-sensitive *E. coli* at 39°C under anaerobic conditions. Each point represents an average of 6 replicates, and error bar is standard deviation.



**Fig. 4.4.** AI-2 activity and OD<sub>600</sub> in chemostat-cultivated *E. coli* Isolate 5 exposed to sub-therapeutic chlortetracycline (2 µg/mL) in LB broth plus 0.5% glucose under anaerobic conditions. Chlortetracycline is added once (arrow indicated) each day for 5 consecutive days in culture growth rate (0.0416 h<sup>-1</sup>) of steady-phase tetracycline-sensitive *E. coli* at 39°C under anaerobic conditions. Each point represents an average of 6 replicates, and error bar is standard deviation.

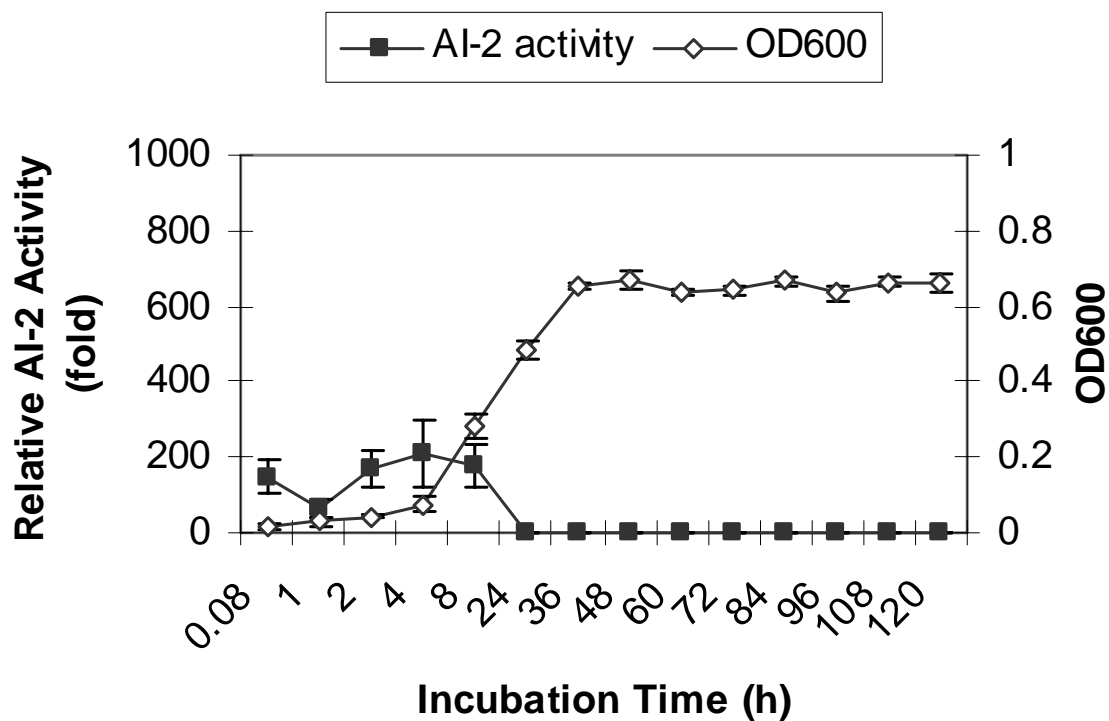


**Fig. 4.5.** Normalized relative AI-2 activity of chemostat-cultivated *E. coli* Isolate 5 exposed to sub-therapeutic chlortetracycline in LB broth. Normalized relative activity is reported as the relative AI-2 activity of the sample divided by the  $OD_{600}$  of the sample. Arrow indicates the point where chlortetracycline is added.



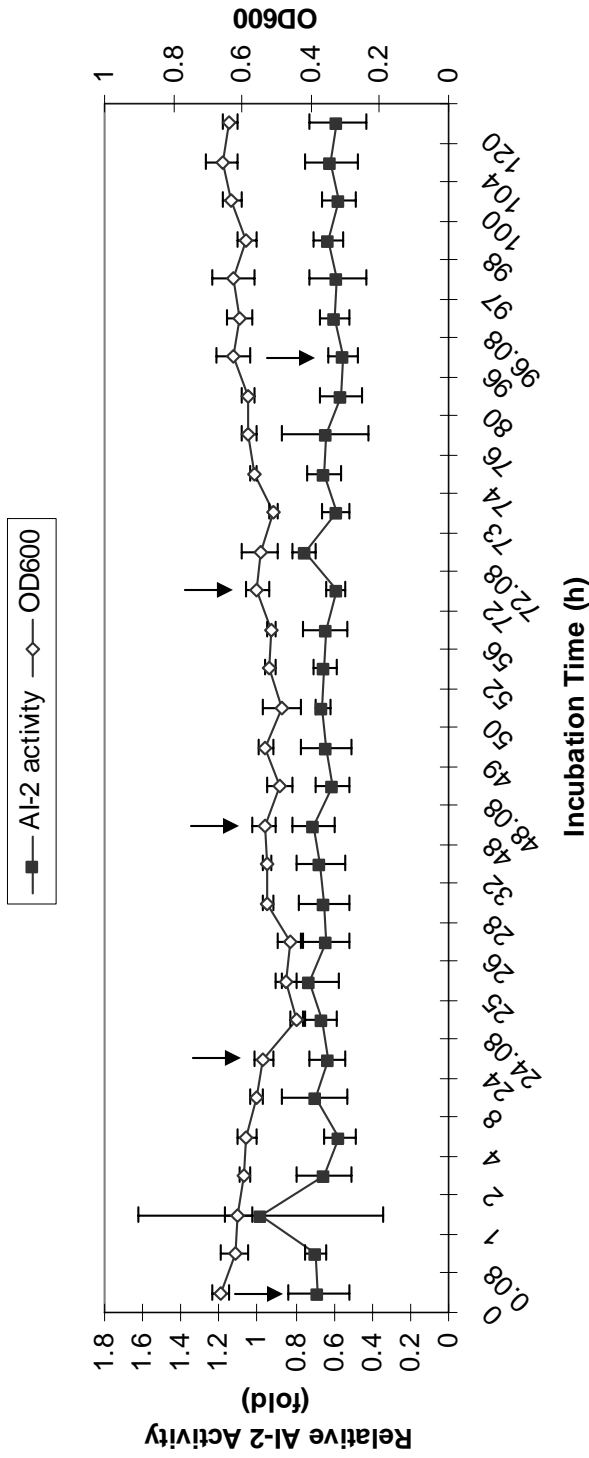
**Fig. 4.6.** Normalized relative AI-2 activity of chemostat-cultivated *E. coli* Isolate 5 exposed to sub-therapeutic chlortetracycline in LB broth plus 0.5% glucose. Normalized relative activity is reported as the relative AI-2 activity of the sample divided by the OD<sub>600</sub> of the sample. Arrow indicates the point where chlortetracycline is added.

**AI-2 activity in Preempt<sup>®</sup> CF3 cultures maintained under continuous culture conditions.** Figure 4.7 shows AI-2 activity within the CF3 culture maintained under steady state conditions. AI-2 activity decreased at 8-h, and was immeasurable by 24-hour post-inoculation. AI-2 activity was also immeasurable when the CF3 cultures were exposed to sub-therapeutic chlortetracycline (4 µg/mL) under anaerobic conditions (Fig. 4.8). AI-2 activity was below detection limits when the CF3 cultures were maintained in VL broth (data not included). To confirm whether there was an AI-2 inhibitory compound(s) being produced by the CF3 culture, equal volume of AI-2-containing CFS from *E. coli* Isolate 5 was mixed with CFS from CF3 cultures maintained in VL broth and the mixture assayed for AI-2 activity (Table 4.1). The results indicate that even though VL broth by itself had no significant effect on AI-2 activity ( $P > 0.05$ ), the CFS from the CF3 cultures grown in VL broth significantly inhibited AI-2 activity by almost 100% as compared to the control sample. The pH of the mixtures (*V. harveyi* reporter strain cultures with AB medium or CFS from CF3) was approximately 6.5 (data not shown). There was no significant difference in the pH between the AB medium and the CFS from CF3 suggesting that pH differences were not responsible for the inhibition from the CF3 culture. There was no significant difference in cell density of the reporter strain ( $P > 0.05$ ) between the control sample in AB medium and the CFS from CF3 cultures either (Table 4.1).



**Fig. 4.7.** AI-2 activity and OD<sub>600</sub> in chemostat-cultivated chicken-derived Preempt<sup>®</sup> CF3 in LB broth at 39°C under anaerobic conditions. Each point represents an average of 6 replicates, and error bar is standard deviation.





**Fig. 4.8.** AI-2 activity and OD<sub>600</sub> in chemostat-cultivated chicken-derived Preempt<sup>®</sup> CF3 exposed to sub-therapeutic level of chlortetracycline (4 µg/mL) in LB broth. Chlortetracycline is added once (arrow indicated) each day for 5 consecutive days in culture growth rate (0.0416 h<sup>-1</sup>) of steady-phase chicken-derived Preempt<sup>®</sup> CF3 maintained in chemostat in LB medium at 39°C under anaerobic conditions. Each point represents an average of 6 replicates, and error bar is standard deviation.

**Table 4.1.** Effect of cell-free supernatants of chicken-derived Preempt<sup>®</sup> CF3 culture on the response of the reporter strain *V. harveyi* BB170 to AI-2 molecules and on the growth of *V. harveyi* BB170

Mixtures <sup>#</sup>	Relative AI-2 activity (fold) <sup>*</sup>	% Inhibition (%) <sup>**</sup>	Viable <i>V. harveyi</i> cells (log10 CFU/mL) <sup>†</sup>
AI-2 + VL broth	75.68 ± 16.57 <sup>a</sup>	-	-
AI-2 + AB medium	93.87 ± 26.70 <sup>a</sup>	-	4.32 ± 0.24 <sup>c</sup>
AI-2 + CFS (Preempt <sup>®</sup> CF3)	0.88 ± 0.034 <sup>b</sup>	100	4.25 ± 0.07 <sup>c</sup>

<sup>#</sup>Mixture was made of equal volume of AI-2-based CFS with each sample of chicken-derived Preempt<sup>®</sup> CF3 culture in VL broth at 39°C under anaerobic conditions or VL broth is mixed, respectively. AB medium is mixed with AI-2 molecule-containing CFS as positive control. The mixtures are subjected to AI-2 bioassay using the reporter strain *V. harveyi* BB170, and AI-2 activity is expressed as relative AI-2 activity in ratio of luminescence unit of sample and negative control; <sup>\*</sup>Relative AI-2 activity (fold) represented the average and standard deviation of triplicate, and values with the same letter were not significantly different (P>0.05); <sup>\*\*</sup>% inhibition was calculated as the formula of

$(1 - \frac{\text{Relative AI-2 activity of the sample}}{\text{Relative AI-2 activity of AB medium as control}}) \times 100$ ; <sup>†</sup>The viable number of reporter strain *V.*

*harveyi* BB170 in the mixture of *V. harveyi* BB170 suspension and cell-free superatant (9:1) after incubation at the same conditions was counted as AI-2 bioassay using direct plating method on AB agar plates, and expressed as log10 (CFU/mL).

***In vivo* AI-2 activity within poultry chicks in response to antibiotic administration.**

The levels of AI-2 activity *in vivo* in response to antibiotic administration are shown in **Table 4.2**. AI-2 activity was exhibited *in vivo* within poultry chicks. Over the 6-week study significant variation in AI-2 activity was shown among each group. Significantly increasing AI-2 activity was observed at week 2. The AI-2 activity decreased significantly by week 3. Vancomycin at sub-therapeutic levels significantly stimulated AI-2 activity compared to the other antibiotics within the first 3 weeks. The increase of AI-2 activity was shown at week 2 relative to the control. However, the difference was not significant due to large variation. At week 6, AI-2 activity in the chlortetracycline treatment group was significantly higher than the control ( $P < 0.05$ ). **Table 4.3** shows the results obtained when samples that showed immeasurable levels of AI-2 activity were analyzed to determine if there were AI-2 inhibitory compounds. It appears that some samples significantly inhibited AI-2 activity.

**Table 4.2.** *In vivo* \* AI-2 activity within poultry chicks in response to antibiotic challenge

Week	Control	Chlortetracycline	Vancomycin	Tylosin
1	4.2±1.2 <sup>a,1</sup>	5.4±2.1 <sup>a,1</sup>	299.1±119.0 <sup>b,2</sup>	4.6±0.9 <sup>a,1</sup>
2	141.9±101.8 <sup>b,1</sup>	288.2±169.4 <sup>b,d,1</sup>	664.1±444.1 <sup>a,2</sup>	127.8±32.2 <sup>b,1</sup>
3	17.3±7.6 <sup>b,1</sup>	9.6±1.6 <sup>a,d,1</sup>	56.3±64.9 <sup>a,2</sup>	8.8±2.26 <sup>a,b,1</sup>
4	27.6±9.5 <sup>c,1,2</sup>	23.0±11.0 <sup>b,c,d,2</sup>	36.0±13.6 <sup>a,1</sup>	9.7±5.4 <sup>b,3</sup>
5	9.6±4.3 <sup>b,1</sup>	12.9±8.0 <sup>a,c,d,1</sup>	9.7±3.6 <sup>a,1</sup>	9.1±4.5 <sup>a,b,1</sup>
6	9.2±5.3 <sup>a,1</sup>	17.6±10.6 <sup>d,2</sup>	12.5±4.6 <sup>a,1,2</sup>	11.8±6.98 <sup>b,1,2</sup>

\*AI-2 activity in each group each week represents an average and standard deviation of 5 chicken cecal contents in triplicate (n=15). Values (in the same treatment) with the same character letter were not significantly different among weeks ( $P>0.05$ ), and values (at the same week) with the same number letter were not significantly different among groups ( $P>0.05$ ).

**Table 4.3.** Effect of cell-free filtrates of chicken cecal contents on response of reporter strain *V. harveyi* BB170 to AI-2 molecules

Mixtures <sup>#</sup>	Relative AI-2 activity (fold) <sup>*</sup>	% Inhibition (%) <sup>**</sup>
AI-2 + AB medium	93.87 ± 26.70 <sup>a</sup>	-
AI-2 + filtrate (A1)	3.40 ± 0.39 <sup>b</sup>	96.4
AI-2 + filtrate (B5)	3.01 ± 0.83 <sup>b</sup>	96.8
AI-2 + filtrate (C4)	0.74 ± 0.06 <sup>c</sup>	100
AI-2 + filtrate (D1)	1.16 ± 0.18 <sup>c</sup>	98.8

<sup>#</sup>Mixture was made of equal volume of AI-2-based CFS with each sample of cell-free filtrates of chicken cecal contents with negative AI-2 activity at week 3 (A1 = chick # 1 in control, B5 = chick # 5 in chlortetracycline, C4 = chick # 4 in vancomycin, and D1 = chick # 1 in tylosin) are mixed. AB medium is mixed with AI-2 molecule-containing CFS as positive control. The mixtures are subjected to AI-2 bioassay using the reporter strain *V. harveyi* BB170, and AI-2 activity is expressed as relative AI-2 activity in ratio of luminescence unit of sample and negative control; <sup>\*</sup>Relative AI-2 activity (fold) represented the average and standard deviation of triplicate, and values with the same letter were not significantly different (P>0.05); <sup>\*\*</sup>% inhibition was calculated as the formula of

$$\left(1 - \frac{\text{Relative AI-2 activity of the sample}}{\text{Relative AI-2 activity of AB medium as control}}\right) \times 100.$$

## DISCUSSION

This study provides an insight into the patterns of AI-2 activity when either *E. coli* or a defined microbial consortium (CF3) are maintained under continuous culture conditions and challenged with sub-therapeutic concentrations of tetracycline. The study also illustrates the *in-vivo* pattern of AI-2 levels in chicken cecum when exposed to sub-therapeutic concentrations of tetracycline, vancomycin and tylosin. The results demonstrate that a tetracycline-sensitive *E. coli* isolate does produce AI-2 in LB broth (with or without glucose). These results are in agreement with previous reports (Surette et al., 1999; DeLisa et al., 2001b). More importantly, the results of this study reveal the potential for *E. coli* to produce AI-2 molecules under anaerobic conditions that normally exist within the intestines. To our knowledge, this is the first study reporting on AI-2 activity in *E. coli* under anaerobic *in vitro* conditions. The pattern of AI-2 activity in the chemostat-maintained *E. coli* isolate was similar to our previous studies as well as that of others (Lu et al., 2003; Surette and Bassler, 1998). Interestingly, however, AI-2 activity decreased by 8-h post-inoculation, even though the cell density was high. DeLisa et al. (2001b) have reported on this non-linear relationship between growth rate and AI-2 activity. They suggest that AI-2 activity can be significantly reduced when the growth rate is  $0.45 \text{ h}^{-1}$ . In this study, the dilution rate was calculated to be approximately  $0.04 \text{ h}^{-1}$ , a 10-fold decrease below the lowest threshold. Insufficient substrates rather than enzymatic inactivation have been reported as the cause for this non-linear relationship (Hardie et al., 2003). Withers and Norsstrom (1998) have reported that when *E. coli* cells are exposed to the high concentrations of AI-2 molecules, cell division is repressed. This could possibly explain the cell density decreases at 8-hour post-inoculation in LB

medium containing glucose compared to LB medium without glucose. The increased AI-2 concentration in the “plus glucose” treatment could have repressed cell division. The increased AI-2 activity in the LB medium containing glucose is in agreement with previous studies (DeLisa et al., 2001b; Beeston and Surette, 2002).

Previous results from our studies have shown that AI-2 activity increased in tetracycline-sensitive *E. coli* isolate when exposed to sub-therapeutic level of tetracycline in LB medium containing glucose under batch culture conditions (Lu et al., 2003). In this study too, AI-2 activity increased in tetracycline sensitive *E. coli* cells when exposed to increasing concentrations of sub-therapeutic concentrations of tetracycline under anaerobic continuous culture conditions. Every time when chlortetracycline was pulsed into the chemostat, AI-2 activity decreased within 5-min post-challenge. However, the decrease in AI-2 activity was lower compared to the previous pulse.

A majority of the previous studies related to quorum sensing have involved pure cultures of bacteria. Autoinducer AI-2 based quorum sensing molecules have been reported in rumen contents (Erickson et al., 2002) and in chemostat-cultivated fecal contents from healthy humans (Sperandio et al., 2003). In this study too, AI-2 activity was detected in chemostat-cultivated chicken-derived microflora of Preempt<sup>®</sup> CF3 culture in LB medium under anaerobic conditions. There were 2 peaks of AI-2 maximal activity, one at 5- min and the other at 4-hour post-inoculation. However, under steady state conditions, and when the cells were exposed to sub-therapeutic concentrations of chlortetracycline, AI-2 activity was below detection limits. There was no measurable AI-2 activity when the CF3 cultures were maintained in VL broth. Based on the experiments that were performed to identify the possible reasons for inhibition, it appears that an

unknown inhibitory compound(s) is/are inhibiting AI-2 activity (**Table 4.1**). It will be interesting to identify whether the inhibition of AI-2 activity in the microbial consortium conditions could be linked to the anti- *Salmonella* Typhimurium and *Listeria monocytogenes* properties of the CF3 microbial consortium (Hume et al., 1996, 1998a, 1998b; Corrier et al., 1995). The possible links between presence of AI-2 activity *in vivo* in the cecal contents of chicks and the susceptibility of chicks to enteric bacterial colonization is worthy of further investigation. The significantly increased AI-2 activity that was observed in the chicks in week 1 and week 2 when exposed to vancomycin but not the other antibiotics is intriguing. The presence of compound(s) inhibitory to AI-2 activity was evident in the cecal contents of the chicks. Overall, these results suggest that AI-2 molecules (a key signal in bacterial quorum sensing) are present though transiently within the microbial consortia in the ceca of young chicks. It is also evident that AI-2 activity can increase within these consortia depending on the type of antibiotic that is administered. Thus, it will be interesting to understand the mechanistic relationships that exist between presence of AI-2 activity, microbial consortia characteristics, and the vulnerability of poultry chicks to enteric bacterial pathogen colonization. We are attempting to address these fundamental questions.



## CHAPTER V

# **AUTOINDUCER 2 (AI-2)-BASED QUORUM SENSING PROMOTES *trbC* GENE EXPRESSION AND CONJUGAL TRANSFER OF *tet(A)* GENE IN RESPONSE TO SUB-THERAPEUTIC TETRACYCLINE EXPOSURE IN *ESCHERICHIA COLI***

### **OVERVIEW**

The horizontal transfer of antibiotic resistance genes among bacteria is considered to be responsible for the dissemination of antibiotic resistance phenotypes. Administration of sub-therapeutic doses of antibiotics such as tetracycline is thought to be responsible for the spread of antibiotic resistance organisms. Laboratory experiments were conducted to identify whether the bacterial quorum sensing signal autoinducer 2 (AI-2) is involved in the expression of genes (*trbC* and *traI*) related to conjugal transfer of genes and to determine whether the presence of AI-2 molecules enhances the transconjugation frequency of a plasmid (RP4) carrying the *tet(A)* gene. The experiments were conducted with *E. coli* AM0076 (harboring plasmid RP4) as donors and *E. coli* AM1087 as recipients. The transfer frequency (based on donor population) was  $3.5 \times 10^{-5}$  -  $3.3 \times 10^{-6}$  when donors were exposed to AI-2 signals in comparison to  $5.4 \times 10^{-7}$  -  $5.5 \times 10^{-7}$  and  $2.0 \times 10^{-6}$  -  $4.5 \times 10^{-7}$  as observed in the negative controls (AI-2 negative samples and LB medium, respectively). Gene expression studies performed using real-time PCR analysis indicated that the pilin-encoding *trbC* gene mRNA levels increased 3.2-fold when exposed to AI-2 molecules, and up to 9.0-fold in cells when the donor cells were exposed to AI-2 molecules plus sub-therapeutic tetracycline for 30 minutes. The relaxase-

encoding *traI* gene mRNA levels, however, were regulated by 0.2-fold (in the presence of AI-2) and 0.6-fold (in the presence of AI-2 and sub-therapeutic tetracycline). These results indicate that AI-2-based quorum sensing can affect the transcription of at least one conjugation-associated gene (*trbC*) and also enhance conjugation transfer frequency of plasmid RP4 carrying *tet(A)* among *E. coli* strains.

## INTRODUCTION

It was as early as 1959 that commensal *E. coli* was shown to serve as a donor for resistance genes to pathogenic *Shigella dysenteriae* (Hartman et al., 2003). Recent studies have shown that antibiotics used either therapeutically or sub-therapeutically can promote the persistence of antibiotic resistance genes within the commensal microflora (Blake et al., 2003b; Khachatryan et al., 2004). Commensal organisms such as *E. coli*, *Bacteriodes* and *Enterococcus* can carry antibiotic resistance plasmids and serve as a repository of antibiotic resistance genes (Roe et al., 2003b; Moubareck et al. 2003; Shoemaker et al., 2001; Bahl et al., 2004; Blake et al., 2003a; Mizan et al., 2002). Gene transfer frequency via conjugation is influenced by a number of factors including cell density, growth phase of donor and recipient cells, and presence of antibiotics and nutrient levels (Smith, 1975, 1977a, 1977b; Fernandez-Astorga et al., 1992; Muela et al., 1994; Blake et al., 2003a; Whittle et al., 2002a, 2002b; Bahl et al., 2004).

Quorum sensing is becoming recognized as a cell density-dependent phenomenon in microorganisms, which allows microbial populations to coordinately control the expression of multiple genes and thereby the physiological processes in bacterial cells (Miller and Bassler, 2001). It is believed that quorum sensing systems are utilized by

bacteria to coordinately regulate their responses to environmental stimuli (Surette and Bassler, 1998; Sperandio et al., 1999, 2001; DeLisa et al., 2001b, 2001c). Presently, 3 different types of autoinducer molecules, namely acylated homoserine lactones (also termed autoinducer 1, AI-1), furanosyl borate diester (AI-2) and oligopeptides, are thought to act as signal molecules for inter- and intra-bacterial communications (Miller and Bassler, 2001; Chen et al., 2002). Different processes such as bioluminescence, virulence expression, plasmid transfer in *Agrobacterium tumefaciens*, biofilm formation, bacterial sporulation, and antibiotic synthesis are regulated by autoinducers in response to environmental stimuli and stresses (Miller and Bassler, 2001; Oger and Farrand, 2002; Sperandio et al., 1999, 2001; Steinmoen et al., 2002; Dong et al., 2000). Autoinducer-based quorum sensing systems are hypothesized to play a role in the development of antibiotic resistance in bacteria. Steinmoen et al. (2002) reported that an oligopeptide pheromone induces *Streptococcus pneumoniae* to become competent for uptake of free DNA from the surrounding medium and incorporation of this DNA into its genome through homologous recombination. Muscholl-Silberhorn et al. (1997) have hypothesized that an oligopeptide secreted by *Staphylococcus aureus* induces gene transfer from *Escherichia faecalis* to *S. aureus*. AI-1 has been shown to regulate replication and conjugation genes of Ti plasmids in *A. tumefaciens* and plasmid pNGR234a in *Rhizobium* sp. strain NGR234 (He et al., 2003; Luo et al., 2003). AI-2 molecules are generally considered as a universal signal molecule in bacterial cells, because LuxS, the protein responsible for the synthesis of AI-2, is highly conserved among both Gram-negative and Gram-positive bacteria (Xavier and Bassler, 2003). Previous studies have shown that AI-2-based quorum sensing controls the expression of a number of different genes

(Sperandio et al., 1999, 2001; DeLisa et al., 2001b, 2001c; Duan et al., 2003; Hammer and Bassler, 2003; Taga et al., 2001).

Previous studies in our laboratory have documented the increase in AI-2 activity in *E. coli* when the cells were exposed to sub-therapeutic concentrations of tetracycline under batch and continuous culture (chemostat) conditions. The underlying hypothesis of the present study was that AI-2-based quorum sensing promotes the development of tetracycline resistance in *E. coli* by enhancing the expression of conjugation-related genes *trbC* and *traI* when exposed to sub-therapeutic tetracycline concentrations. The *trbC* gene encodes the pilin protein that makes up the sex pilus (involved in gene transfer) while the *traI* is involved in relaxosome formation for nicking plasmid DNA. The objectives of this study were to evaluate the influence of AI-2 molecules on a) the expression of the *trbC* and *traI* by using real-time PCR assays to measure gene expression, and b) the transconjugation frequency of a plasmid carrying the tetracycline resistance gene. The transconjugation frequency (in response to the presence of AI-2 molecules) was evaluated using the IncP plasmid RP4, a broad host range conjugative plasmid, which carries the tetracycline resistance gene.

## **MATERIALS AND METHODS**

**Bacterial strains, plasmids, media and growth conditions.** The bacterial strains and plasmids used in this study are listed in **Table 5.1**. *E. coli* strains were grown aerobically at 37°C in Lauria-Bertani (LB; Difco, Detroit, MI) broth or on agar plates and incubated overnight. *E. coli* AM1087 that carries the plasmid pRL277 which confers spectinomycin and streptomycin resistance was used as a recipient, and *E. coli* AM0076 that carries IncP

plasmid RP4 conferring ampicillin, tetracycline and kanamycin resistance was used as a donor in conjugation assays.

**Table 5.1.** Strains and plasmids used in this study

Bacterial strains and plasmids	Genotype and description	Source
<b>Bacterial strains</b>		
<i>E. coli</i> Isolate 1	Poultry isolate, AI-2 producer, Tc <sup>r</sup>	This study
<i>E. coli</i> DH5 $\alpha$	Non-AI-2 producer	J. Golden
<i>E. coli</i> AM1087	Carrying plasmid pRL277, Sp <sup>r</sup> Sm <sup>r</sup> , as recipient	J. Golden
<i>E. coli</i> AM0076	Carrying conjugative plasmid RP4, Tc <sup>r</sup> Amp <sup>r</sup> Kan <sup>r</sup> , as donor	J. Golden
<i>Vibrio harveyi</i> BB170	<i>luxN</i> ::Tn5 sensor 1 <sup>-</sup> sensor 2 <sup>+</sup> for AI-2 assay	B. L. Bassler
<i>Vibrio harveyi</i> BB152	<i>luxL</i> ::Tn5 AI-1 <sup>-</sup> AI-2 <sup>+</sup> as positive control	B. L. Bassler
<b>Plasmids</b>		
RP4	IncP Conjugative plasmid, Tc <sup>r</sup> Amp <sup>r</sup> Kan <sup>r</sup>	J. Golden
pRL277	Sp <sup>r</sup> Sm <sup>r</sup>	J. Golden
pSL18	<i>tet(A)</i> in <i>E. coli</i>	L. K. Ng

The reporter strain *V. harveyi* BB170 (*luxN*::Tn5 sensor 1<sup>-</sup> sensor 2<sup>+</sup>) that only senses AI-2 molecule, and AI-2-producing *V. harveyi* BB152 (*luxL*::Tn5 AI-1<sup>-</sup> AI-2<sup>+</sup>) were used for the AI-2 bioassays. The Autoinducer Bioassay (AB) medium was used as the growth medium for studies involving these cultures (Bassler et al., 1994; Lu et al., 2004).

**Cell-free supernatant (CFS) preparation.** *E. coli* Isolate 1 and *E. coli* DH5 $\alpha$  strain were inoculated (10%, v/v) into LB supplemented with 0.5% glucose, respectively. After 8-h shaken incubation at 37°C, cell-free supernatants (CFS) were prepared by centrifugation (8000 $\times$  rpm for 5 min at 4°C) followed by filtration through 0.2- $\mu$ m-pore size syringe filter (Corning, New York, NY). The CFS was stored at -20°C until used for treatment in gene expression and bacterial mating experiments.

**Growth curve and AI-2 activity in donor and recipient cells.** Individual 50-mL Falcon tubes with LB broth were inoculated (1:10,000) with overnight cultures of either *E. coli* AM0076 (donor) or *E. coli* AM1087 (recipient) and incubated at 37°C with shaking at 100 rpm. Aliquots (1 mL) were collected for the preparation of cell-free supernatants (CFS) as described above, and 1 mL for serial dilutions to enumerate cell number. The CFS samples were stored at -20°C until AI-2 activity was measured.

**AI-2 activity bioassay.** The assay was performed as described by Surette and Bassler (1998). An overnight culture of *V. harveyi* BB170 was diluted (1:5,000) with fresh AB media. Ninety microliters of this cell suspension were mixed with 10  $\mu$ L of the sample obtained above in a 96-well micro-isoplate (Perkin Elmer Life Science Inc., Boston, MA). The cell-free supernatant (10  $\mu$ L) of *V. harveyi* BB152 strains were used as positive controls, and 10  $\mu$ L of AB media was used as the negative control. The micro-isoplates

were shake-incubated (100 rpm) at 30°C in a Lab-Line Orbital Shaker Incubator (Melrose Park, IL). Luminescence was measured every 30 min using a Perkin Elmer Wallac Victor 2 luminometer. AI-2 activity was expressed as *relative AI-2 activity*.

**RNA extraction.** Fifty-milliliter cultures of *E. coli* AM0076 were grown aerobically overnight at 37°C in LB broth with tetracycline (10 µg/mL). The cells were harvested by centrifugation (8000×rpm for 10 min at 30°C) and washed 3 times with pre-warmed LB broth and resuspended in 50-mL fresh LB pre-warmed LB broth. The culture was inoculated (10%, v/v) into a total volume of 10 mL of (i) fresh LB broth; (ii) LB broth plus CFS (80%); and (iii) LB plus CFS and tetracycline (10 µg/mL). The samples were incubated for 30 min at 37°C. The total RNA from these cultures was purified from a 10-mL sample of *E. coli* AM0076 cultures by using Ribopure<sup>TM</sup>-Bacteria kit (Ambion, Austin, TX). Residual DNA was removed by incubation with 2 U of RNase-free DNase (Ambion, Austin, TX) for 30 min at 37°C, followed by incubation with 0.1 volume of DNase inactivation reagent (Ambion) for 2 min at room temperature. The samples were centrifuged to collect the supernatants. The amount of RNA extracted was quantified using a BioPhotometer (Eppendorf, Germany), and its integrity was checked by electrophoresis in 1.5% agarose gels.

**cDNA preparation.** Reverse transcription was performed with 0.2 -1 µg of total RNA incubated with 2 µL of MuLV reverse transcriptase (2.5 U/µL, Applied Biosystems, Foster city, CA) in the presence of random hexamers at the final concentration of 2.5 µM, dNTP (1 mM) and 1 U/µL of RNase inhibitor (Applied Biosystems) in a total reaction volume of 40 µL for 30 min at 42°C followed by 99°C for 5 min and 5°C for 5 min. The cDNA templates were stored at -20°C prior to use in the real-time PCR assay.

**Real-time PCR amplification.** The cDNAs from the different treatments were used as templates for real-time PCR amplification using the ABI prism 7900HT SDS (Applied Biosystems, Foster city, CA). The software was set in the relative quantification mode. The primer sequence and amplicon details are shown in **Table 5.2**. The amplifications were performed in 384-well plates. The 20- $\mu$ L reaction mixtures contained 10  $\mu$ L of SYBR Green PCR master matrix (Applied Biosystems), optimal concentrations of each specific oligonucleotide primer and 1  $\mu$ L of diluted cDNA. The reaction conditions were as follows: 1 cycle at 95°C for 10 min, 40 cycles at 95°C for 15 s and 60°C for 1 min. The concentrations of each pair of the primers were optimized using the combination of forward and reverse primer at the final concentration of 50, 450, 750 and 900 nM. Negative controls without the cDNA templates were run in parallel. Dissociation curves were performed for the amplified product. Each sample was run in triplicate.

**Table 5.2.** Primers used for conjugation-associated gene expression using real-time PCR

Primer <sup>a</sup>	Sequence (5'-3')	T <sub>m</sub> <sup>b</sup> (°C)	Position
16s Rrna-F	<i>CCAGCAGCCGCGGTAAT</i>	59	512-529
16s rRNA-R	<i>TGCGCTTTACGCCAGTAAT</i>	59	573-553
<i>tral</i> -F	<i>CGTCAGTGCCGTGCATCA</i>	60	312-319
<i>tral</i> -R	<i>GGGTCGGGTGAATCTTGTTG</i>	59	382-363
<i>trbC</i> -F	<i>CGCGGCATTTTGTCTACCT</i>	59	37-56
<i>trbC</i> -R	<i>CCGGATGCGCGGATAA</i>	59	100-85

<sup>a</sup> GenBank accession number for 16s rRNA is AJ605115, and X54459 for *tral* and M93696 for *trbC*.

<sup>b</sup> T<sub>m</sub> as calculated with Primer Express 2.0 software (Applied Biosystems, Foster city, CA).



The critical threshold cycle ( $C_t$ ) is defined as the cycle at which the fluorescence becomes detectable above background levels due to incorporation of SYBR Green dye into the double stranded amplified DNA. Fluorescence intensity of SYBR Green dye was normalized to a passive reference dye (carboxy-x-rhodamine, ROX) included in the master matrix. The  $C_t$  value is inversely proportional to the logarithm of the initial copies of template molecules. To quantify *traI* and *trbC* mRNA levels derived from the different treatments namely, CFS (AI-2<sup>+</sup>) and CFS (AI-2<sup>+</sup>) plus tetracycline, the amount of 16s rRNA in each sample was used as an endogenous control for normalization. The *traI* and *trbC* mRNA levels derived from the LB treatment (control) were used as calibrators. The relative quantity (fold) of the target genes was expressed as the following formula of

$$\frac{\text{mRNA levels in treatment}}{\text{mRNA levels in control}} = 2^{-\Delta\Delta C_t}$$

where  $\Delta\Delta C_t = (C_t^{\text{target gene}} - C_t^{16s \text{ rRNA}})_{\text{treatment}} - (C_t^{\text{target gene}} - C_t^{16s \text{ rRNA}})_{\text{control}}$ .

The RNA was extracted from each of the different treatments and analyzed using the real-time PCR assay.

**Bacterial mating experiments.** Experiments were conducted to evaluate whether AI-2 molecules enhanced the transfer frequency of the transmissible plasmid RP4. Bacterial mating assays were performed in liquid as described by Thomas et al. (2000) with minor modifications. Briefly, *E. coli* AM0076 (donor) and *E. coli* AM1087 (recipient) were grown separately on LB agar plates containing their respective antibiotics. After overnight incubation at 37°C, a single colony was used to inoculate separately 30 mL of LB broth containing the appropriate antibiotic and incubated overnight at 37°C with shaking (80 rpm). The donor and recipient cells were washed 3 times with pre-warmed LB broth. The recipient cells were suspended in 5 mL of pre-warmed LB broth, and

donors were suspended in 5 ml of LB broth containing 80% cell-free supernatant (AI-2<sup>+</sup>). The 80% CFS concentration was chosen based on previous studies which showed that 80% CFS provides detectable responses if any. The donor and recipient cultures were incubated at 37°C for 30 min. The donor cells treated with LB broth and LB plus CFS from *E. coli* DH5 $\alpha$  (a non AI-2 producing strain) were used as negative controls. Each treatment was prepared in triplicates. Equal volume (1 mL) of donor and recipient cells were mixed, and these mixtures were incubated for 30 min at 37°C. The *E. coli* transconjugants were selected on LB agar plates containing the appropriate antibiotics as selective agents at appropriate concentrations. The antibiotic concentrations were used as follows: streptomycin, 20  $\mu$ g/mL; spectinomycin 20  $\mu$ g/mL; ampicillin, 100  $\mu$ g/mL; tetracycline, 10  $\mu$ g/mL and kanamycin, 50  $\mu$ g/mL. The transconjugant colonies were enumerated after overnight incubation at 37°C. The donor and recipient cell numbers were also enumerated on LB agar.

The transconjugants that were selected were sub-cultured in LB broth under selective pressure. The transconjugants were later subjected to pulse field gel electrophoresis (PFGE) analysis (to determine whether plasmid RP4 and pRL227 coexisted in transconjugants) and PCR amplification (to confirm the presence of *tet(A)* gene).

**Pulsed field gel electrophoresis.** To determine whether plasmid RP4 and pRL227 coexisted in transconjugants, pulse-field gel electrophoresis (PFGE) analysis was performed. Overnight cultures of transconjugants in LB broth with selective antibiotics were pelleted by centrifugation at 20°C for 5 min at 8000  $\times$  rpm. The cells were washed twice with 0.01 M of phosphate buffer saline (PBS, pH 7.2), and suspended in PBS.

Equal volumes of pre-heated (45°C in a water bath) 1% low melting point agarose (Bio-Rad Laboratories, Richmond, CA) and cell suspensions were mixed gently. The mixtures were poured into molds and held at 4°C to solidify plugs. The transconjugants cell-embedded plugs were incubated overnight at 50°C in lysis solution (0.5M EDTA (Sigma Chemical Co., St. Louis, MO), pH9.3, 1% N-lauroyl-sarcosine (Sigma), 0.2 mg/ml Proteinase K (Boehringer Mannheim, Indianapolis, IN)). One plug from each sample was treated with phenylmethylsulfonyl fluoride (Sigma Chemical Co.), and washed for 30 min three times with TE (10 mM Tris (USB Specialty Biochemicals, Division of Amersham Life Science, Inc., Cleveland, OH), pH 8.0; 1 mM EDTA) followed by equilibration with digestion buffer for nuclease S1 according to manufacturer's instruction (Promega, Madison, WI). One plug of each sample was digested with 6 U of nuclease S1 for 1 h at 37°C, and one third of each plug was placed in wells of a 1% agarose gel (Roche Diagnostics, Indianapolis, IN). PFGE was performed on a CHEF Mapper<sup>®</sup> XA Pulsed Field Gel Electrophoresis System (Bio-Rad Laboratories) in 0.5× TBE (Tris-Boric acid-EDTA (0.089 M Tris, 0.089 M boric acid, 0.001 M EDTA (pH8.0)) for 15.16 h at 12°C with initial switch time of 0.22 s, final switch time of 3.36 s (for 5-60 Kb fragments), and voltage of 6.0 V/cm. Gels were stained with ethidium bromide for 30 min and de-stained with 1 mM of magnesium sulfate for another 30 min. Images were recorded using a digital imaging system (ChemiImager 4000 Low Light Imaging System, AlphaEase Software, version 3.3a, Alpha Innotech Corporation, San Leandro, CA).

**PCR amplification for *tet(A)*.** Overnight cultures of transconjugants in LB broth with selective antibiotics (ampicillin, tetracycline, streptomycin and spectinomycin) were

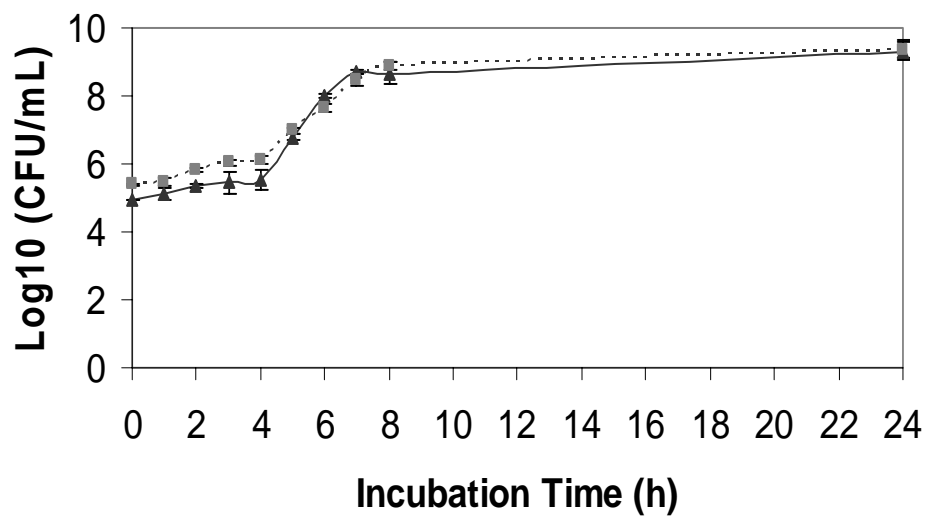
pelleted with centrifugation, and suspended in 200  $\mu$ L of PrepMan<sup>TM</sup> Ultra reagent (Applied Biosystems, Foster city, CA). The DNA was extracted from these cell pellets per the manufacturer's recommendations. Three microliters of the final supernatant was used for PCR amplification. The PCR primers for the amplification of *tet(A)* were F-*GCTACATCCTGCTTGCCTTC* and R-*CATAGATCGCCGTGAAGAGG*, which produced 210 bp. The Hot start PCR protocols were used and the reactions were conducted on the GeneAmp<sup>®</sup> PCR system 2700 (Applied Biosystems) using the following cycling conditions.: 94°C for 5 min for 1 cycle, and 35 cycles of 94°C for 1 min, 55°C for 1 min and 72°C for 1.5 min followed by a final extension of 72°C for 10 min and 4°C for holding. The PCR products were analyzed on a 2% agarose gel in 0.5 $\times$ TBE and documented using a digital image capture system.

**Statistics analysis.** All experiments were done in triplicate. AI-2 activity was expressed as *relative AI-2 activity*, which was calculated as the ratio of bioluminescence of the test sample to the negative control sample. Transconjugant frequency was calculated by dividing transconjugant numbers observed in each treatment groups by the initial number of donor and recipient cells, respectively.

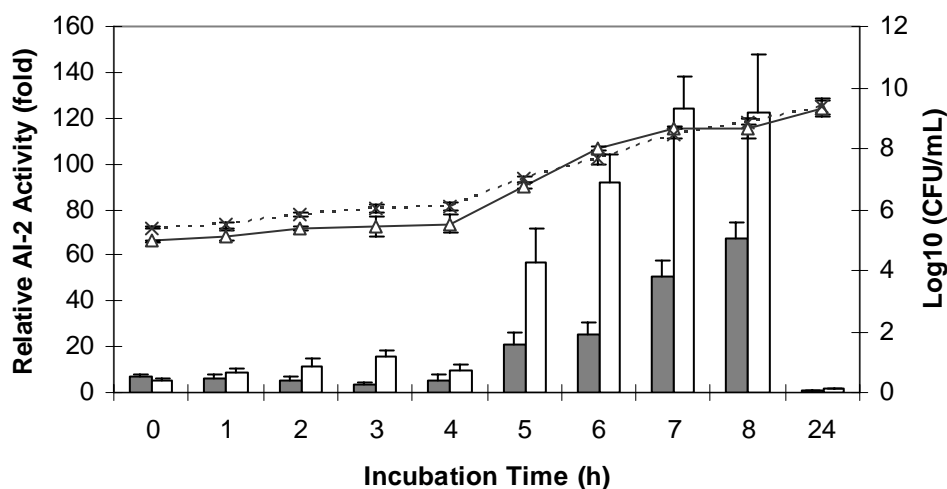
## RESULTS

**AI-2 activity.** Figures 5.1 and 5.2 show the growth kinetics and AI-2 activity in *E. coli* AM1087 (recipient) and *E. coli* AM0076 (donor) in LB broth under batch culture conditions. Overnight cultures of donor or recipient were inoculated into fresh LB broth displayed typical growth pattern within 24 h. AI-2 production started to increase significantly at exponential phase in both donor and recipient, and reached maximum at

early stationary phase (ca. 8 h), while AI-2 levels decreased extremely to undetectable levels at the stationary phase (24 h).



**Fig. 5.1.** Growth pattern of *E. coli* AM0076 (donor cells) and *E. coli* AM1087 (recipient cells) at 37°C in LB broth. Each point represents the average and standard deviation of triplicates. Solid line, *E. coli* AM0076, and dot line, *E. coli* AM1087.



**Fig. 5.2.** Relative AI-2 activity and *E. coli* populations at 37°C in batch culture. *E. coli* AM0076 (donor cells) (solid bar = relative AI-2 activity; solid line = bacterial cell numbers) and *E. coli* AM1087 (recipient) (blank bar = relative AI-2 activity, dot line = bacterial cell numbers). Values represented as the mean and standard deviation of triplicates.

**Effect of AI-2 on conjugation frequency.** Laboratory strain *E. coli* DH5 $\alpha$  does not produce AI-2 molecules (Surette et al., 1999) and the CFS from *E. coli* DH5 $\alpha$  were also used as negative controls in this experiment. **Table 5.3** shows the conjugation frequency in the 30-min. bacterial mating experiments. When the donor cells were exposed to AI-2-containing CFS (AI-2<sup>+</sup>) for 30 min, the transconjugation frequency ranged between  $3.5 \times 10^{-5}$  -  $3.3 \times 10^{-6}$  per donor or  $4.3 \times 10^{-5}$  -  $4.6 \times 10^{-6}$  per recipient. In contrast, when the donor cells was treated with cell-free supernatant (AI-2<sup>-</sup>) of *E. coli* DH5 $\alpha$ , conjugation

frequency was  $5.4 \times 10^{-7}$  -  $5.5 \times 10^{-7}$  per donor and  $2.6 \times 10^{-6}$  -  $2.7 \times 10^{-6}$  per recipient. When LB broth was used as the other negative control, the transconjugation frequency of  $2.0 \times 10^{-6}$  -  $4.5 \times 10^{-7}$  per donor and  $1.3 \times 10^{-6}$  -  $7.2 \times 10^{-7}$  per recipient was observed.

Representative plasmid profiles of the transconjugants as observed with PFGE are shown in **Figure 5.3**. The transconjugants displayed three plasmids ranging in size from 60, 23 and 6.5 Kb which corresponds to the plasmids in the donor and the recipient cells. The PCR amplification showed the presence of the characteristic 210-bp-sized amplicon which is indicative of the presence of *tet(A)* in the transconjugants (**Fig. 5.4**).

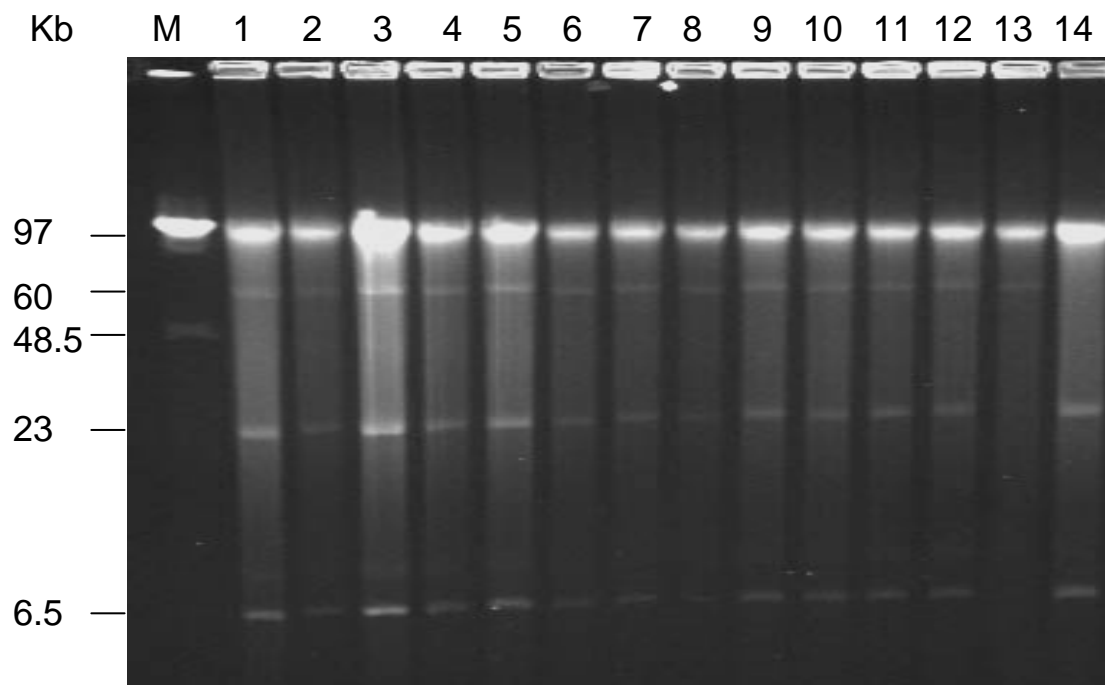
**Table 5.3.** Transconjugation frequency of IncP plasmid RP4 in *E. coli* as affected by exposure to AI-2 containing cell free supernatant (CFS)

Treatment	Range of transconjugation frequency <sup>a</sup> (# conjugants/ #donors)	Range of transconjugation frequency <sup>b</sup> (# conjugants/# recipients)
CFS (containing AI-2 activity)	$3.5 \times 10^{-5}$ - $3.3 \times 10^{-6}$	$4.3 \times 10^{-5}$ - $4.6 \times 10^{-6}$
CFS (without AI-2 activity)	$5.4 \times 10^{-7}$ - $5.5 \times 10^{-7}$	$2.6 \times 10^{-6}$ - $2.7 \times 10^{-6}$
LB	$2.0 \times 10^{-6}$ - $4.5 \times 10^{-7}$	$1.3 \times 10^{-6}$ - $7.2 \times 10^{-7}$

<sup>a</sup> Transconjugation frequency based on the number of transconjugants per input donor;

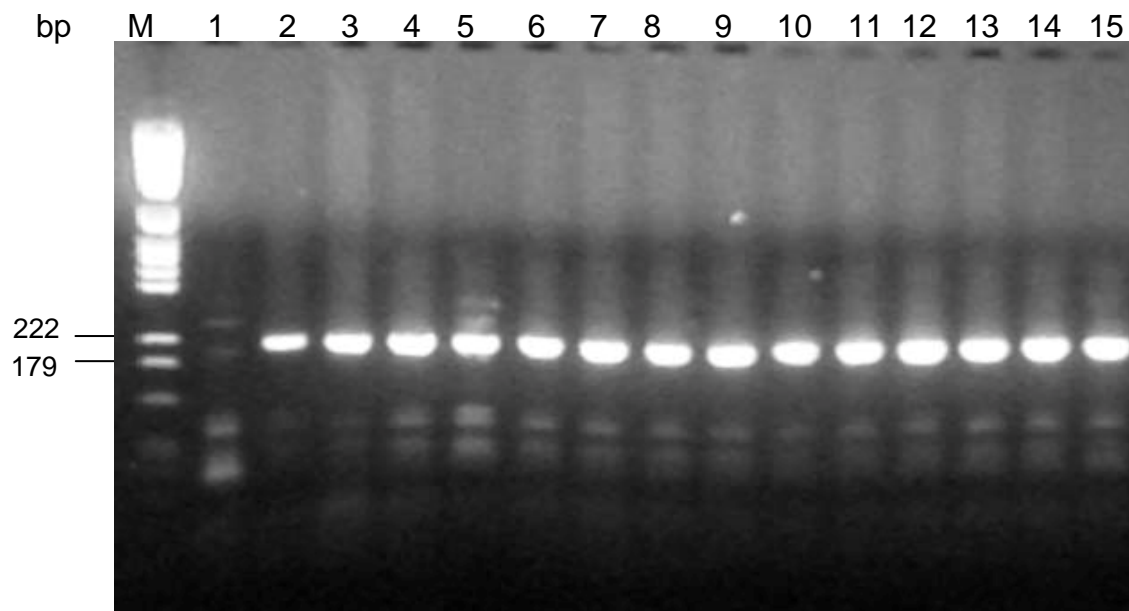
<sup>b</sup> Transconjugation frequency based on the number of transconjugants per input recipient;

The data represent the average range of three independent experiments, each experiment has triplicate.



**Fig. 5.3.** Plasmid profile analysis of representative transconjugants by PFGE. Lane M, PFG ladder ( $\lambda$ ) DNA marker; Lanes 1-12, transconjugants; Lane 13, donor of *E. coli* AM0076; Lane 14, recipient of *E. coli* AM1087.





**Fig. 5.4.** PCR amplification for *tet(A)* gene on plasmid RP4 in transconjugants. Lane M, Benchtop pGEM<sup>®</sup> DNA marker; Lane 1, recipient of *E. coli* AM1087; Lane 2, donor of *E. coli* AM0076; Lanes 3-14, transconjugants; Lane 15, pSL18 as positive control.

**Fig 4.** PCR amplification for *tet(A)* gene on plasmid RP4 in transconjugants. Lane M, Benchtop pGEM<sup>®</sup> DNA marker; Lane 1, recipient of *E. coli* AM1087; Lane 2, donor of *E. coli* AM0076; Lanes 3-14, transconjugants; Lane 15, pSL18 as positive control.

**Expression of *traI* and *trbC* genes on plasmid RP4 in *E. coli*.** The expression of conjugation-related gene *trbC* and *traI* was quantified using real-time PCR amplification. For each of the gene, amplifications were performed on three replicate RNA samples (which were obtained from the three experimental replicates) from each treatment. The abundance of *trbC* mRNA levels increased 3.2-fold in LB plus CFS (containing AI-2) and 9.0-fold in LB plus CFS (containing AI-2 and tetracycline), compared to the *trbC* mRNA that were observed in the CFS from LB broth (**Table 5.4**). In contrast, the levels of *traI* mRNA were 0.2- fold in LB plus CFS (containing AI-2) and 0.6-fold in LB plus CFS (containing AI-2 and tetracycline), compared to the levels of *traI* mRNA in LB control samples.

**Table 5.4.** Relative quantitation of *traI* and *trbC* gene mRNA level using real-time PCR<sup>a</sup>

Treatment	<i>traI</i>	<i>trbC</i>
LB (negative control)	1	1
CFS (containing AI-2 activity)	0.2 ± 0.057	3.2 ± 0.117
CFS (containing AI-2 activity) + tetracycline (10 µg/ml)	0.6 ± 0.202	9.0 ± 1.463

<sup>a</sup>Levels of *traI* and *trbC* genes are shown as mean ± standard deviation (n=9) in comparison to LB broth as negative control.

## DISCUSSION

The results clearly show that AI-2 activity is involved in enhancing the expression of the pilin –encoding *trbC* gene and is also involved in promoting conjugation. These results, to the best of our knowledge, are the first to demonstrate that AI-2 –based quorum sensing is directly involved in enhancing transconjugation frequency and the expression of genes involved in conjugation-related activities. The AI-2 activity in both donor and recipient cells in LB broth started to increase significantly from 5-h post-inoculation in LB medium and reached its maximum at early stationary phase. It has been reported that maximum piliation is attained at the end of the exponential phase and that maximal conjugation frequency is also detectable at the early stationary phase of donor cells (Novotny and Lavin, 1971; Muela et al., 1994). These early studies support our results. In this study, we used CFS from a prolific AI-2 producer (*E. coli* Isolate 1) from the exponential phase and added it to fresh LB broth (4:1, vol:vol; CFS:LB) to treat the donor cells for 30 min. The donor and recipients cells were incubated together for another 30 minutes, and mixed equal volume of the donors and the recipients in liquid condition for another 30 min. The transconjugation frequency (based on donor cells) arising from donor cells that were exposed to AI-2 molecules was 10- to 100-fold compared to transconjugants arising from donors treated by CFS from control treatments such as *E. coli* DH5 $\alpha$  (a non-AI-2 producing strain), and 10-fold relative to LB broth. It must be emphasized here that the increased transconjugation frequency that was observed may actually be an underestimation because both the donor and recipient cells produce AI-2 molecules and so even the negative control (cells exposed LB medium alone) may have been exposed to some AI-2 molecules originating from the cells themselves. This

assumption is supported by the sizeable difference in the transconjugation frequency that was observed between the *E. coli* DH5 $\alpha$  CFS-treated group and the LB broth-treated group.

A number of different steps at the molecular level are involved in conjugation (Maloy et al., 1994). Mating pair formation (Mpf) and the transfer of nicked single stranded plasmid DNA in the relaxosome are two such steps. In the plasmid RP4, two distinct regions designated Tra1 and Tra2 encode essential transfer functions (Lessl et al., 1992a, 1992b). Genes of *trbB*, *trbC*, *trbE*, *trbG* and *trbL* located in the Tra2 region are responsible for encoding the essential components for Mpf system (Lessl et al., 1993). The gene product of *trbC*, has been identified as the precursor of pilin, which is consequently processed to form pilus (Eisenbrandt et al., 1999; Sherburne et al., 2000). Walmsley (1976) reported that mating pair formation is a limiting step during conjugation under normal physiological conditions. The gene expression results show that *trbC* gene was up-regulated in samples that were treated with CFS containing AI-2 activity, as well as those samples that were treated with CFS containing AI-2 activity and exposed to sub-therapeutic concentrations of tetracycline. Considering that pilus formation is a limiting step in conjugation, it is not surprising that AI-2-based quorum sensing up-regulates *trbC* gene expression. The results of the gene expression are in agreement with the transconjugation frequency data which shows a 10-fold increase in donor cells exposed to CFS containing AI-2 activity compared to the negative controls. Previous studies in our laboratory have shown that sub-therapeutic tetracycline exposure stimulated AI-2 increasing in *E. coli*, and AI-2 molecules, in turn, induce tetracycline tolerance in *E. coli*. These results which demonstrate the involvement of AI-2 molecules

at the molecular level support the results obtained by Whittle et al. (2002b) who reported that tetracycline at sub-therapeutic levels resulted in an increase in transfer protein expression and a concomitant increase in the transfer frequency. Also, recently, an *in vivo* study suggested that the number of transconjugants was significantly higher for animals fed with tetracycline at sub-therapeutic levels than for those not fed with tetracycline (Bahl, et al., 2004). Showsh and Andrews (1992) have also reported that transfer rate mediated by conjugative Tn916 increases in the presence of tetracycline as well. Although there are inherent differences between plasmid and transposon-mediated conjugation events, one commonality between these two processes is mating-pair formation (Salyers and Shoemaker, 1992; Speer et al., 1992; Stevens et al., 1992). It has also been reported that transposase expression is up-regulated by AI-2-based quorum sensing (Sperandio et al., 2001; DeLisa et al., 2001c). These previous studies in conjunction with our present results demonstrate that AI-2 activity is involved in enhancing the expression of genes that are specific to gene transfer events. These results provide an intriguing picture in terms of the role of bacterial quorum sensing, sub-therapeutic tetracycline exposure and the transfer of tetracycline resistant genes.

In the current study, AI-2-based quorum sensing did not appear to significantly enhance the expression of the *traI*. We speculate that the less-than enhanced expression of *traI* may be a cost-effective strategy that bacteria have developed. We had evaluated the expression of the 2 genes in cells that were exposed to CFS for 30 minutes. It is possible that the relaxase-encoding *traI* gene expression occurs before *trbC* gene expression is initiated. Relaxase binds to *oriT* of plasmid DNA to form the relaxosome, nicking DNA so it is ready to transfer when a signal indicating formation of a stable

mating complex is received. This signal could arise from the binding of sex pilus between the donor and recipient cell, and could be part of an Mpf component that resides at the outer-membrane side of the mating apparatus structure (Haase et al., 1995; Street et al., 2003). It is possible that in the samples that were studied by real-time PCR analysis, the *traI* expression may have already declined to near background levels by the time the *trbC* gene expression had initiated. Thus, our experimental conditions of 30-minute contact time between donor and recipients cells may have been too long to detect significant increases in *traI* gene expression. This hypothesis has, however, not been verified.

Overall, these results suggest that AI-2-based quorum sensing can affect at least one gene transcription of *trbC* and ultimately enhances conjugation transfer frequency of plasmid RP4 carrying *tet(A)* among *E. coli* strains.

## CHAPTER VI

# AUTOINDUCER 2 (AI-2)-LIKE ACTIVITY ASSOCIATED WITH FOODS AND ITS INTERACTION WITH ORGANIC ACIDS USED AS FOOD ADDITIVES\*

### OVERVIEW

The autoinducer 2 (AI-2) molecule produced by bacteria as part of their quorum sensing is considered to be a universal inducer signal in bacteria since it reportedly influences gene expression in a variety of both Gram-negative and Gram-positive bacteria. The objective of this study was to determine whether selected fresh produce and foods have AI-2-like activity and whether specific food additives can act as AI-2 mimics and result in an AI-2-like activity. The luminescence-based response of the reporter strain *Vibrio harveyi* BB170 was used as the basis of determining AI-2 activity in the selected foods and food ingredients. Maximum AI-2 activity was seen on the frozen fish sample (203-fold as compared to the negative control) followed by tomato, cantaloupe, carrots, tofu and milk samples. Interestingly, some samples were capable of inhibiting AI-2 activity. Turkey patties showed the highest inhibition (99.8% compared to the positive control) followed by chicken breast (97.5%), homemade cheeses (93.7%), beef steak (90.6%) and beef patties (84.4%). AI-2 activity was almost totally inhibited by sodium propionate while sodium benzoate caused a 93.3% inhibition as compared to 75%

---

\*Reprinted with permission from "Autoinducer-2-like activity associated with foods and its interaction with food additives" by Lingeng Lu, Michael E. Hume and Suresh D. Pillai, 2004, *Journal of Food Protection*, 67(7), 1457-1462. Copyright© 2004 by International Association for Food Protection.

inhibition by sodium acetate. Sodium nitrate did not have any appreciable effect even at 200 ppm. Understanding the relationships that exist between the AI-2 activity on foods and the ecology of pathogens and food-spoilage bacteria on foods may yield clues about factors controlling food spoilage and pathogen virulence.

## INTRODUCTION

Bacterial cells within microbial communities are thought to coordinately regulate the expression of their genes by producing and responding to specific molecules termed autoinducers, a process which has been termed as *quorum sensing* (Bassler et al., 1997; Sperandio et al., 2003). The quorum sensing signaling pathway has been well described in the bioluminescent bacterium *Vibrio harveyi* (Bassler et al., 1994; Miller et al., 2002; Mok et al., 2003). In *V. harveyi*, two autoinducer molecules, AI-1, an acylated homoserine lactone signal and AI-2, a furanosyl borate diester molecule, are thought to be involved (Miller et al., 2002; Surette et al., 1999; Winzer et al., 2002a). When the concentrations of AI-1 and AI-2 reach a particular threshold within the cells, they bind their respective sensor proteins, LuxN and LuxPQ, resulting in a cascade of enzyme phosphorylation which ultimately results in specific gene expression (Bassler, 1999). The AI-2 signal molecule is considered to be a universal inducer signal in bacteria since it has been reported to influence gene expression in a variety of both Gram-negative and Gram-positive bacteria. AI-2 synthesis requires the LuxS protein, which is a highly conserved protein sequence within bacterial genera (Cloak et al., 2002; Surette et al., 1999). Studies have shown that bioluminescence in the aquatic bacterium *Vibrio harveyi*, virulence expression in *Pseudomonas aeruginosa*, toxigenic *Escherichia coli*, *Salmonella*



Typhimurium, plasmid transfer in *Agrobacterium tumefaciens*, biofilm formation, sporulation and antibiotic production in *Erwinia carotovora* are all influenced by autoinducer molecules (Bainton et al., 1992; Bassler et al., 1997; Davies et al., 1998; Luo and Farrand, 2001; Oger and Farrand, 2002; Qin et al., 2000; Sperandio et al., 2001). The current thinking is that quorum sensing allows bacterial cells to survive as a group by coordinating their behavior in response to environmental stress stimuli and host interactions.

Studies with enteric bacteria have shown that bacterial byproducts such as the short-chain fatty acids, e.g. acetate and propionate, can also regulate gene expression. Exposure of *S. Typhimurium* to acetate leads to an increase in invasion gene expression, while propionate exposure results in a decrease of invasion gene expression at neutral pH conditions as well as induction of acid resistance (Arnold et al., 2001; Kwon and Ricke, 1998; Lawhon et al., 2002; Van Immerseel et al., 2003). Even though AI-2 activity in *E. coli* K12 was found to decrease after exposure to 0.6% sodium acetate, another study has found that the synthesis of the protein responsible for AI-2, the LuxS protein, was actually induced by exposure of the cells to 50 mM acetic acid (DeLisa et al., 2001b; Kirkpatrick et al., 2001). The realization that signal molecules such as AI-1 and AI-2 and other bacterial byproducts such as acetate and propionate influence gene expression raises the bigger question whether foods contain such signal molecules or mimic molecules and what roles these molecules have in modulating gene expression in pathogenic or spoilage bacteria. For example, it has been reported that the infective dose of *S. Typhimurium* is significantly reduced when the cells are ingested with a food source (cheddar cheese) (D'Aoust, 1985). Another study has shown that *S. Typhimurium*

survival markedly increases under acidic conditions (pH 3.0) when the cells are inoculated onto fresh-cut vegetables and fruits such as tomato, apple and cucumber (Gawande and Bhagwat, 2002). Recent studies have also theorized that AI-1 molecules were present in spoiled beef that had been stored in a refrigerator (Jay et al., 2003). Some plants such as pea seedlings, tomatoes and rice have also been found to secrete AI-1 molecules (Teplitski et al., 2000).

The underlying *hypothesis* is that the presence of varying levels of the autoinducer molecules (AI-2) on foods could possibly explain why certain foods have characteristic shelf-lives and why certain enteric pathogens can become virulent when exposed to certain types of foods. The objective of this study was to determine whether fresh produce and processed foods have AI-2 activity and whether specific food additives can act as AI-2 mimics and cause the typical AI-2-like activity in the *V. harveyi* reporter strain. The reporter strain *V. harveyi* strain BB170 response was used as the basis of determining AI-2 activity in the selected foods and food ingredients in this study.

## **MATERIALS AND METHODS**

**Bacterial strains and assay medium.** The reporter strain *V. harveyi* BB170 (*luxN::Tn5* sensor 1<sup>-</sup> sensor 2<sup>+</sup>) that only senses AI-2 molecule, and AI-2-producing *V. harveyi* BB120 (AI-1<sup>+</sup> AI-2<sup>+</sup>) and BB152 (*luxL::Tn5* AI-1<sup>-</sup> AI-2<sup>+</sup>) were used for the AI-2 bioassays in this study (Surette and Bassler, 1998; Surette et al., 1999). These strains were kindly provided by Dr. Bassler (Princeton University, Princeton, NJ). The AB (autoinducer bioassay) medium was prepared as following. A solution consisting of NaCl (17.5 g/L, Sigma Chemical Co., St. Louis, MO), MgSO<sub>4</sub> (12.3 g/L, Fisher Chemicals,

Fisher Scientific, Fair Lawn, NJ), Casamino acids (2 g/L, Fisher Chemicals) was adjusted to pH 7.5, and sterilized by autoclaving (15 min, 121°C, 15 psi) . When the solution had cooled down, autoclave-sterilized 1 M potassium phosphate (pH 7.0, 10 ml/L, Sigma Chemical Co.), 50% glycerol (20 ml/L, EM science, Gibbstown, NJ) and filter-sterilized 0.1 M L-arginine (10 ml/L, Sigma Chemical Co.) were added. Freshly prepared cell-free supernatants (CFS) from natural *E. coli* isolates that have been previously shown to produce AI-2 molecules in our laboratory were used as exogenous AI-2 in inhibition assays.

**Food samples and food ingredients.** Retail samples of salad tomatoes, raw whole carrots, cantaloupes, calcium fortified orange juice, beef steak, beef patties, chicken breast, turkey patties, frozen fish (red drum), tofu, soymilk, organic whole milk (ultra-pasteurized, grade A), regular whole milk, and fresh cheese (Mozzarella and Goat milk) were purchased from local supermarkets. Food additives such as sodium acetate, sodium nitrate, sodium propionate, sodium benzoate were obtained from Sigma Chemical Company (St. Louis, MO). The food additives were tested for AI-2 activity at the levels recommended by the FDA for their use in foods (21 CFR Ch. I; the Code of Federal Regulation Chapter 1, 2001). These levels were: sodium acetate (0.007%, 0.05%, 0.2%, 0.5%, 1%), sodium nitrate (125 ppm, 250 ppm, and 500 ppm), sodium propionate (0.08%, 0.16%, and 0.32%), sodium benzoate (0.025%, 0.05%, and 0.1%).

**Processing of food samples for AI-2 activity evaluation.** The surfaces of the different vegetables were swabbed with an AB medium-wetted cotton swab (VWR International, West Chester, PA) and the swab resuspended in tubes containing 3 mL of AB medium. Fifty grams of the chicken breast and beef steak samples were placed in sterile Whirl-

Pak<sup>®</sup> bags (VWR International) to which 10 mL of cold (4°C) AB medium was added (to avoid too much dilution for AI-2). Fifty grams of the beef patties, turkey patties, and cheese sample were also placed in Whirl-Pak<sup>®</sup> bags, to which 20 mL cold AB medium was added. The samples were gently shaken by hand for 1 min and 1 mL of the sample suspensions was placed in sterile 1.5 mL micro-centrifuge tubes. One milliliter of organic milk, regular whole milk, soymilk, and tofu and fish samples (from excess liquid in the packages of tofu and fish) were directly placed into sterile 1.5 mL micro-centrifuge tubes. The samples were centrifuged for 5 min (8000 × rpm at 4°C), and subsequently filtered through 0.2-µm-pore-size syringe filter (Corning, New York, NY) to obtain cell-free supernatants (CFS). The CFS samples were stored at -20°C until the AI-2 activity bioassays were performed. Portions of the suspension of selected food samples (beef steak, beef patties, chicken breast, turkey patties, milk and goat milk fresh cheese) (prior to centrifugation and filtration) were plated on R2A agar (Becton Dickinson, Cockeysville, MD) for bacterial estimations.

**AI-2 activity bioassay.** The bioluminescence response of the reporter strain *V. harveyi* strain BB170 was used as the basis of determining AI-2 activity in the foods and food ingredients in this study. *V. harveyi* BB170 is an engineered strain that can only respond to AI-2 molecules. The *luxCDABE*-encoded bioluminescence is initiated when the AI-2 signal is present to produce bioluminescence i.e., when the AI-2 molecules present in the test sample are bound to the receptor for AI-2 (sensor 2). The assay was performed as described by Surette and Bassler (1998). An overnight culture of *V. harveyi* BB170 was diluted (1:5,000) with fresh AB media. Ninety microliters of this cell suspension were mixed with 10 µL of the sample extract obtained above in a 96-well micro-isoplate

(Perkin Elmer Life Science Inc., Boston, MA). The cell-free supernatant (10  $\mu$ L) of *V. harveyi* BB120 and BB152 strains were used as positive controls, and 10  $\mu$ L of AB media was used as the negative control. To identify whether the food additives or food samples were inhibiting the induction of luminescence in the reporter strain *V. harveyi* BB170, an equal volume (50  $\mu$ L) of these samples and the CFS from the known AI-2 producer (*E. coli* natural isolate) were mixed together and the AI-2 activity assayed. The food additive concentrations of sodium acetate, sodium benzoate, sodium propionate and sodium nitrate for these tests were 0.1%, 0.1%, 0.16% and 200 ppm, respectively.

The micro-isoplates were shake-incubated (100 rpm) at 30°C in a Lab-Line Orbital Shaker Incubator (Melrose Park, IL). Luminescence was measured every 30 min using a Perkin Elmer Wallac Victor 2 luminometer. AI-2 activity was expressed as *relative AI-2 activity*, which was calculated as the ratio of luminescence of the test sample to the control (negative) sample.

***V. harveyi* reporter strain BB170 susceptibility to food additives.** Overnight AB medium cultures of *V. harveyi* BB170 were diluted (1:5,000) with fresh AB medium. The subculture of *V. harveyi* BB170 and each food additive sample was added to an individual sterilized tube according to the ratio of 9:1 (vol: vol, *V. harveyi* BB170: food additive solution sample) as AI-2 bioassay, and then incubated at 30°C for the same incubation time as the AI-2 bioassay. A serial dilution was made for enumerating viable cells of *V. harveyi* BB170 on Mueller-Hinton agar (Acumedia, Baltimore, MD).

**Data and statistical analysis.** All experiments were run in triplicates. AI-2 activity was expressed as *relative AI-2 activity*, which was calculated as the ratio of bioluminescence of the test sample to the negative control sample. The “inhibition of AI-2-like activity”

was calculated based on the relative AI-2 activity of the positive control. The positive control was chosen as 100%. Mathematically, the “inhibition of AI-2-like activity” was calculated on the following formula:  $100 - \frac{\text{relative AI} - 2 \text{ activity of the test sample}}{\text{relative activity of the positive control}}$ . The data were analyzed using General Linear Model (GLM) of SAS software (version 8.0, SAS Institute Inc., Cary, NC). A p value of 0.05 was used as a critical value for statistical significance.

## RESULTS

**AI-2 activity on produce and food samples.** The response (AI-2 expressed in relation to that of the negative control) of the reporter strain *V. harveyi* BB170 to the produce washes and rinses of processed food samples is shown on **Table 6.1**. Maximum AI-2 activity was seen on the frozen fish sample (203-fold as compared to the negative control) followed by tomato, cantaloupe, carrots, tofu and milk. Very low levels of AI-2 activity (less than 1 fold) were observed in the beef steak, beef patties, chicken breast, turkey patties, cheese, and soymilk samples. Bacterial populations in the beef steak, beef patties, chicken breast and turkey patty rinses ranged between 6.4 and 7.9 ( $\log_{10}$  CFU/mL) on R2A agar (**Table 6.1**). However, the cheese rinses, organic and regular milk samples had less than  $2 \log_{10}$  CFU/mL of bacteria on R2A plates. In order to rule out the possibility that some component of the produce or food wash was inhibitory to the reporter strain’s activity, the CFS from a known AI-2 producer (*E. coli* natural isolate) was mixed (1:1) with these low AI-2 activity samples and tested using the AI-2 bioassay (**Table 6.2**). It was evident that some of the rinse samples did indeed inhibit the ability of the reporter strain *V. harveyi* BB170 to elicit AI-2 activity. The turkey patties showed the

highest level of inhibition (99.8%) followed by chicken breast (97.5%), homemade cheeses (93.7%), beef steak (90.6%) and beef patties (84.4%) when compared to the positive control. When the pH of the mixture of the food sample rinses and diluted *V. harveyi* BB170 culture was measured, they were found to range from 6.4 to 6.7. The pH of the AB medium was 6.7 thereby, ruling out pH as a possible factor in the inhibition (data not included).

**Table 6.1.** AI-2 activity and indigenous bacterial populations in produce rinses and food extracts

Produce/Food	Relative AI-2 activity*	Log <sub>10</sub> (CFU/mL)
Tomato	121.13±22.98 <sup>a</sup>	ND <sup>**</sup>
Carrot	56.21±5.41 <sup>b</sup>	ND
Cantaloupe	58.38±39.86 <sup>b</sup>	ND
Beef steak	0.54±0.04	7.4±0.32
Beef patties	0.54±0.07	6.4±0.24
Chicken breast	0.53±0.10	8.0±0.30
Turkey patties	0.56±0.13	7.0±0.24
Cheese (goat milk)	0.55±0.03	<2
Cheese (Mozzarella)	0.54±0.07	ND
Fish	203.75±23.10 <sup>c</sup>	ND
Organic milk	4.09±0.25 <sup>d</sup>	<2
Whole milk	7.37±1.10 <sup>e</sup>	<2
Soy milk	1.94±0.42 <sup>f</sup>	ND
Tofu	29.43±3.80 <sup>g</sup>	ND

\* *Relative AI-2 activity* (fold increase) calculated as the ratio of luminescence of the test sample to the control (negative) sample. Relative AI-2 activity represented as mean ± standard deviation (n=3). Values with the same letter are not significantly statistically different (P>0.05).

\*\* ND, not determined.

**Table 6.2.** Inhibition of AI-2 activity by food extracts

Mixture (1:1)	Relative AI-2 activity (fold) <sup>*</sup>	% inhibition <sup>**</sup>
CFS + AB medium (positive control)	519.03±28.87 <sup>a</sup>	
CFS + Beef steak	48.93±14.74 <sup>d</sup>	90.6
CFS + Beef patties	81.18±9.15 <sup>c</sup>	84.4
CFS + Chicken breast	12.99±1.43 <sup>e f</sup>	97.5
CFS + Turkey patties	1.24±0.12 <sup>g</sup>	99.8
CFS + Cheese (goat milk)	180.31±11.69 <sup>b</sup>	65.3
CFS + Cheese (Mozzarella)	32.72±7.61 <sup>d e</sup>	93.7

<sup>\*</sup>Relative AI-2 activity is shown as mean ± standard deviation (n=3). Values with the same letter are not significantly statistically different (P>0.05).

<sup>\*\*</sup>Inhibition (%) calculated based on the positive control values.

**AI-2-like activity of food additives.** Commonly used food additives such as sodium acetate, sodium benzoate, sodium propionate and sodium nitrate were tested at FDA recommended concentrations to determine if they could mimic AI-2 activity with the *V. harveyi* reporter strain BB170 (**Table 6.3**). None of the food additives had AI-2 activity greater than a 1-fold increase in AI-2 activity as compared to the negative control. To determine whether the absence of AI-2 activity was a result of the food additive inhibiting the induction of luminescence in the reporter strain, an equal volume of the 4 food additives was mixed with the CFS of a known AI-2 producer (*E. coli* natural isolate)



and the resultant AI-2 activity was measured (**Table 6.4**). The 50:50 (vol:vol) ratio was chosen so that the final concentrations of sodium acetate, sodium benzoate, sodium propionate and sodium nitrate in these reaction mixtures were 0.1%, 0.1%, 0.16%, and 200 ppm, respectively, and within the FDA recommended levels. There was almost total inhibition of AI-2 activity by sodium propionate. AI-2 activity was inhibited (93.3%) by sodium benzoate and up to 75% by sodium acetate. Surprisingly, sodium nitrate did not have any appreciable effect even at 200 ppm. The final pH of these reaction mixtures was around 6.6 as compared to 6.5 for the AB medium and 6.45 for the CFS of the AI-2 producer (data not included). To confirm that the reduced AI-2 activity was not the result of growth inhibition of the reporter strain (*V. harveyi* BB170), the influence of food additives on the multiplication of the reporter strain was also studied (**Table 6.5**). The food additives were tested at 0.1% or 0.16% since it was at these concentrations that AI-2 activity inhibition was observed. A mixture (1:9) of the food additive in combination with the diluted reporter strain *V. harveyi* BB170 in AB medium was incubated at 30°C mentioned previously. At the end of the incubation period, portions of the samples were plated on Mueller-Hinton Agar (**Table 6.5**). There were no significant differences between the positive control and the various treatments suggesting that inhibition of reporter strain growth was not the basis of AI-2 activity inhibition by the food additives.

**Table 6.3.** AI-2 activity of selected food additives

Food additive concentration (%) <sup>a</sup>	Relative AI-2 activity (fold) <sup>b</sup>
Sodium Acetate	
1.0	0.57±0.05
0.5	0.63±0.19
0.2	0.68±0.09
0.05	0.73±0.06
0.007	0.74±0.05
Benzoic acid (sodium salt)	
0.1	0.60±0.11
0.05	0.60±0.19
0.025	0.61±0.15
Propionic acid (sodium salt)	
0.32	0.60±0.10
0.16	0.63±0.04
0.08	0.53±0.05
Sodium nitrate	
500	0.71±0.03
250	0.73±0.08
125	0.59±0.02

<sup>a</sup>FDA recommended concentrations used in food (21 CFR Ch.1).

<sup>b</sup>Relative AI-2 activity represented as mean ± standard deviation (n=3) as compared to negative control.

**Table 6.4.** Inhibition of AI-2 activity by selected food additives

Mixture (1:1)	Relative AI-2 activity <sup>*</sup> (fold )	% inhibition <sup>**</sup> (%)
CFS + AB medium (positive control)	93.87±26.70 <sup>a</sup>	-
CFS + 0.1% Sodium acetate	23.54±8.17 <sup>b</sup>	74.9
CFS + 0.1% Sodium benzoate	6.33±0.76 <sup>c</sup>	93.3
CFS + 0.16% Sodium propionate	0.34±0.07 <sup>d</sup>	99.6
CFS + 200 ppm Sodium nitrate	81.14± 21.87 <sup>a</sup>	-

<sup>\*</sup>Relative AI-2 activity represented as mean ± standard deviation (n=3). Values with the same letter are not significantly statistically different (P>0.05).

<sup>\*\*</sup>Inhibition (%) calculated based on the positive control values.

**Table 6.5.** Effect of food additives on the growth of the reporter strain *V. harveyi* BB170

Treatment	Log <sub>10</sub> (CFU/mL) <sup>*</sup>
AB medium	4.3±0.24 <sup>a</sup>
0.1% Sodium acetate	4.5±0.12 <sup>a</sup>
0.1% Sodium Benzoate	4.7±0.33 <sup>a</sup>
0.16% Sodium propionate	4.9±0.09 <sup>a</sup>

<sup>\*</sup>Cell populations represented in log<sub>10</sub> (CFU/mL) as mean ± standard deviation (n=3). Values with the same letter are not significantly statistically different (P>0.05).

## DISCUSSION

There were significant differences in the AI-2 activity of the produce rinses with tomato having the highest relative activity (**Table 6.1**). Previous studies have shown that another autoinducer molecule (AI-1) mimic can be found in the extracts of some plants such as pea, tomato and rice (Teplitski et al., 2000). It is probable that the AI-2 activity observed on the surfaces of the produce in this study either originated from the indigenous bacteria on the surfaces of these vegetables and/or were secreted by the plants in response to environmental or biotic stimuli. It will not be surprising if the AI-2 activity originated from the bacterial cells, because bacteria are known producers of AI-2 molecules and vegetable produce are exposed to soil or airborne organisms at various stages of cultivation, harvest and processing (Beuchat and Ryu, 1997; Endley et al., 2003a, 2003b). Recent studies have shown that some fruits such as tomatoes, strawberries and pineapples produce 2, 5-dimethyl-4-hydroxy-3(2H)-furanone (DMHF), which have AI-2 activity when assayed using the reporter strain *V. harveyi* BB170 (Schauder et al., 2001; Winzer et al., 2002b). It will be extremely critical to understand whether the AI-2 present on the surfaces of fruits and vegetables enable the bacterial cells to survive environmental stimuli, enhance bacterial virulence, promote bacterial attachment to surfaces or promote their internalization into fruits and vegetables (Guo et al., 2001, 2002; Itoh et al., 1998). The possibility that fruit and vegetable rinses can influence the virulence properties of enteric bacteria was highlighted by another study which showed that produce extracts could influence *S. Typhimurium* growth responses (Nutt et al., 2003). Frozen seafood had the highest AI-2 activity while beef, chicken, turkey, and cheese significantly inhibited AI-2 activity. There does not appear to be any correlation

between the presence or absence of AI-2 activity and indigenous bacterial numbers in selected food samples. For example, beef, chicken and turkey samples harbored bacterial populations ranging between 6.4 to 7.9 log<sub>10</sub> CFU/mL, without exhibiting significant AI-2 activity. However, although the bacterial populations in regular milk and organic milk are less than 2 log<sub>10</sub> CFU/mL, AI-2 activity of the milk samples were 4.09 and 7.37 folds, respectively. The elevated levels of AI-2 activity in fish could be due to the possible presence of *Bacillus* spp., and *Vibrio* spp on fish which are known AI-2 producers (Jay, 2000a; Miller et al., 2002; Surette et al., 1999). However, it is not clear why AI-2 activity was observed in tofu (relative AI-2 activity 29.43-fold) but not in soymilk (1.94-fold) even though they are both made from soybeans. It is also noteworthy that though regular milk and organic milk had relatively low levels of AI-2, pasteurization and ultra-pasteurization did not completely inactivate AI-2 activity. Previous studies have shown that AI-2 can withstand heating at 80°C but not 100°C (Surette and Bassler, 1998).

The lack of AI-2 activity on meat products such as beef, chicken and turkey is surprising given their indigenous bacterial population loads. This is not likely the result of dilution, since we washed 50 g of beef steak and chicken breast with 10 mL of AB medium, and 50 g of each sample of beef patties, turkey patties, goat milk cheese and Mozzarella cheese with 20 mL of AB medium, respectively. However, it is significant that certain foods have the ability to partially or completely inhibit AI-2 activity (**Tables 6.1 and 6.2**). There were differences in AI-2 activity inhibition observed between Mozzarella and goat-milk cheese (**Table 6.2**). We are currently attempting to identify the component(s) that may be inhibiting AI-2 activity in these products.

The inhibitory effects of certain food additives such as sodium propionate and sodium benzoate are noteworthy. Food additives are used in the food industry at FDA recommended concentrations to prevent, or delay the spoilage of foods thereby prolonging the shelf life and preserving the quality. Antimicrobial compounds also inactivate, or inhibit the growth of food-borne pathogenic bacteria such as *E. coli* O157:H7, *S. Typhimurium* and *L. monocytogenes* (Rhee et al., 2003). The mode of action of these compounds is thought to be pH-dependent. Antimicrobial compounds at low pH conditions are in the un-dissociated form, thereby can enter the microbial cells where compounds then become dissociated, resulting in the decrease of pH and microbial inactivation (Jay, 2000b). Studies now show that acid adaptation response and acid resistance can overcome the inactivation caused by organic acids (Berry and Cutter, 2000; Davidson and Harrison, 2002; Leyer et al., 1995). Exposure to short-chain fatty acids, for example, acetate and propionate, at neutral or nearly neutral pH has been shown to increase acid resistance of *E. coli* K12 and *E. coli* O157:H7 (Arnold et al., 2001). It is tempting to speculate that the inhibitory effects (on AI-2) of specific food additives such as propionate and benzoate may have a role in the development of acid resistance or adaptation on the following lines of reasoning. Since AI-2 is a universal auto-inducer molecule that regulates a variety of enzyme activities, it is possible that if a particular food additive inhibits AI-2 activity, the microbial cells in that microenvironment may become non-responsive to external stimuli such as antimicrobials. There is published information to support our hypothesis. Regulatory factors such as  $\sigma^S$ , an alternate promoter-recognition subunit of RNA polymerase, that are known to be influenced by quorum sensing signals such as AI-2, are involved in bacterial responses to

food additive stresses (Arnold et al., 2001; Lazazzera, 2000; Rees et al., 1995). In this study neither acetate, benzoate, propionate nor nitrate mimicked AI-2 activity. Rather, acetate, benzoate, and propionate at 0.1%, 0.1% and 0.16%, respectively, had significantly inhibitory effects on the ability of the reporter strain to sense pre-formed AI-2 molecules in the test mixture (**Table 6.4**). This inhibition was obviously not a function of the pH of the reaction mixture or the inhibitory effects of the additives on the multiplication of the reporter strain (**Table 6.5**). We hypothesize that acetate, benzoate and sodium propionate may be actually inhibiting the ability of bacterial cells to quorum sense (i.e., not sensing the presence of AI-2 molecule). This prevents the cells from responding to such acid stimulus and exhibiting what we would consider as “acid tolerance”. Quite interestingly, enteric pathogens such as *E. coli*, *Shigella* and *Salmonella* produce only low levels of acetate and are virtually unable to produce propionate (Krishnan et al., 1998). Pretreatment of *Shigella flexneri* 2a with the mixture of acetate and propionate has been shown to significantly reduce fecal blood and mucus and improves clinical symptoms of shigellosis in rabbits (Rabbani et al., 1999). Further defined experiments are needed to completely elucidate the mechanism of acetate, benzoate and propionate repression of the response of *V. harveyi* BB170 to AI-2-like molecules, and the relationship between the repression of the response to AI-2-like molecules and repression and modulation of genes critical in survival, virulence and pathogenicity.

In conclusion, this study has shown that certain vegetable produce, foods and food ingredients have elevated levels or reduced levels of AI-2 activity or, in some case can inhibit AI-2 activity. Understanding the relationships that exist between the AI-2 activity

on foods and the activity of food spoilage bacteria or pathogens on these foods can have a tremendous impact on our ability to identify and formulate foods that are microbiologically safe and with extended shelf-lives.



**CHAPTER VII**

**A NON-INDOLE-BASED AIRBORNE QUORUM SENSING  
MOLECULE CAN CONFER TETRACYCLINE TOLERANCE IN  
PHYSICALLY SEPARATED *ESCHERICHIA COLI* AND  
*SALMONELLA* NEWPORT STRAINS**

**OVERVIEW**

Bacterial cells use quorum-sensing systems for communication and regulation of gene expression in response to environmental stimuli via autoinducer (AI)-1- and AI-2-based quorum sensing molecules in liquid cultures. Here we provide preliminary evidence for a novel, yet-to-be characterized, airborne molecule that appears to mediate signaling between *Salmonella* Newport and *E. coli* to develop tolerance to sub-therapeutic tetracycline when using bi-partite Petri plates. Induction of tolerance to tetracycline was observed in Tet<sup>s</sup> *E. coli* and Tet<sup>s</sup> *S. Newport* when either *E. coli*, or *S. Newport*, or *E. coli* MDAI2 (*luxS*::Tc<sup>r</sup>) was used as the signaling population. However, no tolerance induction was observed in Tet<sup>s</sup> *E. coli* or Tet<sup>s</sup> *S. Newport* when cell-free supernatants (CFS) were used as the signaling molecule. These results suggests that a non-indole, non-AI-1 and non-AI-2 based quorum sensing system exists for communication between *E. coli* and *S. Newport* through an airborne molecule.

## INTRODUCTION

Bacterial cells utilize inter- and intra-species communication signals termed autoinducers to coordinately regulate microbial gene expression. These communication signals which are thought to be part of larger microbial quorum sensing mechanisms include oligo-peptides, acylated homoserine lactones and furanosyl borate diester molecules (Bassler, 2002; Chen et al., 2002; Sperandio et al., 2001; Surette and Bassler, 1998). The quorum sensing signaling pathway has been well described in the bioluminescent bacterium *Vibrio harveyi* (Freeman and Bassler, 1999; Mok et al., 2003). In *V. harveyi*, two autoinducer (AI) molecules, AI-1, an acylated homoserine lactone signal and AI-2, a furanosyl borate diester molecule, are thought to be involved (Chen et al., 2002; Mok et al., 2003). The AI-1 signal molecules have been shown to control a myriad of physiological processes such as bioluminescence, virulence expression, Ti plasmid conjugation, and antibiotic production (Bassler et al., 1997; Byers et al., 2002; Dong et al., 2001; Hentzer et al., 2003; Oger and Farrand, 2002). However, *E. coli* and *Salmonella* produce AI-2 molecules but not AI-1 (Surette and Bassler, 1998). The AI-2 signal molecule is considered to be a universal inducer signal in bacteria since it has been reported to widespread and influence gene expression in a variety of both Gram-negative and Gram-positive bacteria (Xavier and Bassler, 2003). At least 404 genes in *E. coli* O157:H7 are known to be regulated by AI-2 and 242 genes exhibited significant transcription changes in response to AI-2 signals in a laboratory strain (DeLisa et al., 2001c; Sperandio et al., 2001). More recent studies have shown that classes of bacterial signaling molecules of AI-2 can be widespread among both Gram-negative and Gram-

positive bacteria (Cloak et al., 2002; Day and Maurelli, 2001; Jones and Blaser, 2003; Ohtani et al., 2002; Surette et al., 1999).

Bacterial cells are thought to employ AI-2 as a universal signaling molecule to respond to environmental stimuli. Indole has also been identified as a quorum sensing molecule in *E. coli* (Wang et al., 2001). It has been reported that indole controls the expression of *gabT*, *astD* and *tnaB* genes that function in the uptake, synthesis and degradation of amino acids. Recently, indole has also been implicated as an airborne molecule that conferred ampicillin resistance between physically separated *E. coli* populations (Heal and Parsons, 2002). Studies in our laboratories have shown that AI-2 molecules can also influence the development of tetracycline tolerance among susceptible *E. coli* when exposed to sub-therapeutic tetracycline concentrations and that AI-2 like activity can be found on the surfaces of a number of fresh produce and processed foods (Lu et al., 2004). The underlying hypothesis of this study is that quorum sensing pathways can operate even between physically separated bacterial populations. To test the hypothesis we employed two different bacterial genera (*Escherichia coli* and *Salmonella*) that were physically separated to investigate whether they would coordinately respond to tetracycline stress. The specific objective of this study was to identify whether airborne quorum sensing factors were involved in the development of tetracycline tolerance in physically separated *E. coli* and *S. Newport* strains.

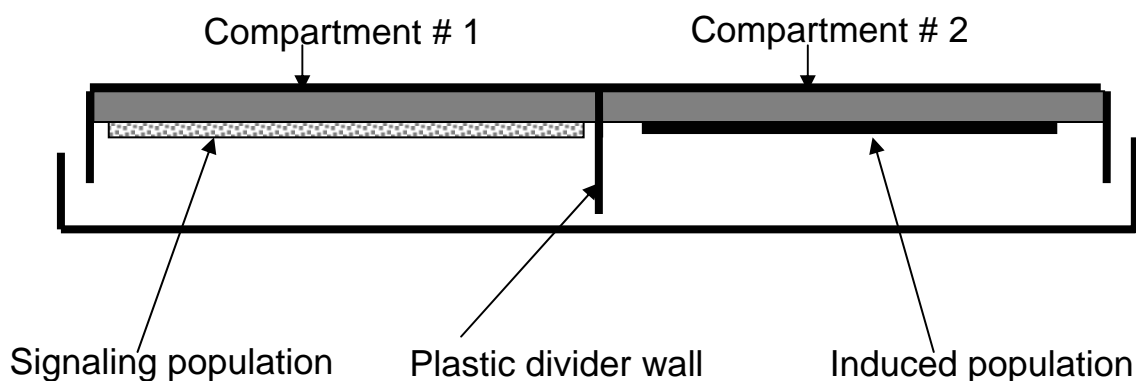
## MATERIALS AND METHODS

**Bacterial strains and media.** A Tet<sup>r</sup> *E. coli* Isolate 1 (MIC $\geq$  128  $\mu\text{g}/\text{mL}$ ), Tet<sup>s</sup> *E. coli* Isolate 5 (MIC $<$ 1  $\mu\text{g}/\text{mL}$ ) and Tet<sup>s</sup> *S. Newport* (MIC $<$ 1  $\mu\text{g}/\text{mL}$ ) were previously isolated from poultry, irrigation water and carrot samples, respectively. *E. coli* MDAI2 (*luxS::Tc<sup>r</sup>*) was obtained from William E. Bentley in University of Maryland. All the cultures were stored in 25% of glycerol at -70°C. The cultures were grown in LB medium as needed with the appropriate antibiotics. Mueller-Hinton agar was used for tetracycline susceptibility analysis. Reagent grade tetracycline was purchased from Sigma Chemical Co. (St. Louis, MO).

**Cell-free supernatant.** Cell-free supernatants (CFS) were prepared as described by Surette and Bassler (1998). Briefly, overnight cultures of *E. coli* Isolate 1 was inoculated in to 20 mL of LB broth supplemented with 0.5% glucose, and shake incubated at 37°C for 8 h. The CFS was prepared by centrifugation (8000  $\times$  rpm for 5 min at 4°C) followed by filtration through 0.2- $\mu\text{m}$ -pore-size syringe filter (Life Science Products, Inc., Frederick, CO). The CFS was stored at -20°C until further use.

**Bacterial antibiotic susceptibility.** Bi-partite Falcon I Petri plates (Becton Dickinson and Company, Franklin lakes, NJ) as illustrated in **Figure 7.1** were used to demonstrate the presence of airborne signalling molecules. Cultures designated as “signaling populations” were spread plated on to LB agar in Compartment # 1 of the bi-partite plate with a sterile cotton swab. The plates were incubated at 37°C for 24 hours to obtain a thick growth. Twenty microliters of a 10<sup>5</sup> dilution of a log-phase culture of either Tet<sup>s</sup> *E. coli* or Tet<sup>s</sup> *S. Newport* were plated on to fresh Mueller-Hinton agar containing varying levels (0, 1, 2, 4 and 8  $\mu\text{g}/\text{mL}$ ) of tetracycline that was previously prepared in

Compartment # 2 of the bi-partite Petri dishes. The plates were incubated at 37°C for 24 h and the plates were scored (+/-) for colony formation in Compartment # 2. Colonies from Compartment # 2 were re-streaked on tetracycline-amended media to identify whether the cells were tetracycline resistant or tolerant. For purposes of this study, we have defined tetracycline tolerance as the ability of the cells to grow in the presence of any concentration of tetracycline, but the inability of the cells to express this phenotype during subsequent transfers on to media containing tetracycline. In contrast, tetracycline resistance was defined as the ability of the cells to exhibit the resistance phenotype even after multiple transfers of the cells.



**Fig. 7.1.** Experimental set up for the airborne quorum sensing-based induction of tetracycline tolerance in *E. coli* and *S. Newport* with a Bi-partite Falcon I Petri plate.

## RESULTS

Tetracycline tolerance development was observed in the Tet<sup>s</sup> *E. coli* Isolate 5 that was plated in Compartment # 2 when the Tet<sup>r</sup> *E. coli* Isolate 1 was employed as the “signaling population” in Compartment # 1 (**Table 7.1**). The Tet<sup>s</sup> *E. coli* Isolate 5 formed visible colonies on plates containing 1 to 4 µg/mL of tetracycline-supplemented agar only when Tet<sup>r</sup> *E. coli* Isolate 1 was present in Compartment # 1. No colonies formed on plates containing 8 µg/mL of tetracycline. No colonies were observed even at 1 µg/mL of tetracycline-supplemented agar when grown in the absence of Tet<sup>r</sup> *E. coli* Isolate 1. When approximately 10% of the colonies that grew on the tetracycline-amended were re-streaked on tetracycline-amended agar on conventional plates, no colonies developed (data not shown). Growth was only observed in the bi-partite plates when the colonies were present across the barrier.

When the cell-free supernatant (CFS) of the Tet<sup>r</sup> cells was placed in Compartment # 1, no colonies of the Tet<sup>s</sup> developed in Compartment # 2 even at tetracycline concentrations as low as 1 µg/mL (**Table 7.1**). To study that AI-2 molecules were not involved in the development of tetracycline tolerance, we employed an AI-2 mutant *E. coli* MDAI2 (*luxS::Tc<sup>r</sup>*) as the “signaling population” in Compartment # 1. The results that whether Tet<sup>s</sup> *E. coli* Isolate 5 formed colonies or not on the tetracycline-supplemented agar in Compartment # 2 were the same as when AI-2 producer of Tet<sup>r</sup> *E. coli* Isolate 1 was employed as the “signaling population” (**Table 7.1**). We also observed that when the signaling population (Tet<sup>r</sup> *E. coli* Isolate 1) and the Tet<sup>s</sup> *E. coli* Isolate 5 were plated on Compartments # 1 and # 2 respectively at the same time, no tetracycline tolerant colonies developed among the Tet<sup>s</sup> *E. coli* isolate (data not included).

**Table 7.1.** Tetracycline tolerant sub-populations in Tet<sup>s</sup> *E. coli* and Tet<sup>s</sup> *S. Newport* when exposed to airborne quorum sensing molecules

Signaling strain in Compartment # 1 <sup>a</sup>	Tet <sup>s</sup> <i>E. coli</i> Isolate 5 <sup>b</sup>				Tet <sup>s</sup> <i>S. Newport</i> <sup>c</sup>			
	Tetracycline concentration				Tetracycline concentration			
	(μg/mL)				(μg/mL)			
	1	2	4	8	1	2	4	8
<sup>d</sup> Tet <sup>f</sup> <i>E. coli</i> Isolate 1 (AI-2 <sup>+</sup> )	+ <sup>g</sup>	+	+	-	+	+	+	-
<sup>e</sup> <i>E. coli</i> MDAI2 ( <i>luxS</i> ::Tc <sup>f</sup> )	+	+	+	-	+	+	+	-
<sup>b</sup> Tet <sup>s</sup> <i>S. Newport</i> (indole <sup>-</sup> )	+	+	-	-	not applicable			
<sup>f</sup> Cell-free supernatant (AI-2 <sup>+</sup> )	-	-	-	-	-	-	-	-
None	-	-	-	-	-	-	-	-

<sup>a</sup>A confluent lawn of these strains was grown on unamended LB agar overnight at 37°C as the “signaling population”.

<sup>b</sup>Tet<sup>s</sup> *E. coli* Isolate 5 (tetracycline MIC < 1 μg/mL); <sup>c</sup> Tet<sup>s</sup> *S. Newport* (tetracycline MIC < 1 μg/mL).

<sup>d</sup>Tet<sup>f</sup> *E. coli* Isolate 1 (tetracycline MIC ≥ 128 μg/mL); <sup>e</sup>*E. coli* MDAI2 (*luxS*::Tc<sup>f</sup>) (AI-2 negative).

<sup>f</sup>Cell free supernatant containing AI-2 molecules obtained from *E. coli* Isolate 1.

<sup>g</sup>+ represents colonies form on the plates.

When the Tet<sup>s</sup> *S. Newport* was plated in Compartment # 2, they were able to produce colonies on 1 to 4 µg/mL tetracycline-amended media either when the Tet<sup>r</sup> *E. coli* Isolate 1, or the *E. coli* MDAI2 (*luxS::Tc<sup>r</sup>*) were used as the “signaling population” (**Table 7.1**). As expected no colonies formed in the absence of a “signaling population”.

We employed a non-indole producing enteric organism, *S. Newport* sensitive to tetracycline (MIC < 1 µg/mL) as the “signaling population” to verify that the airborne signal molecule observed in these studies was not indole-based. The Tet<sup>s</sup> *E. coli* Isolate 5 was streaked on Compartment # 2. The Tet<sup>s</sup> *E. coli* Isolate 5 formed tetracycline tolerant colonies on 1 µg/mL and 2 µg/mL tetracycline amended media but not on 4 µg/mL of tetracycline (**Table 7.2**). The number of tolerant colonies on 1 µg/mL and 2 µg/mL tetracycline-amended media were approximately 53% and 13% respectively as compared to the control plate containing no selective pressure. Additionally, the colonies that developed on the tetracycline-amended Compartment # 2 exhibited morphological differences. The colonies that were close to the signaling population (i.e. close to the barrier) appeared normal while those further away from the barrier exhibited a pin-point morphology (**Fig. 7.2**).



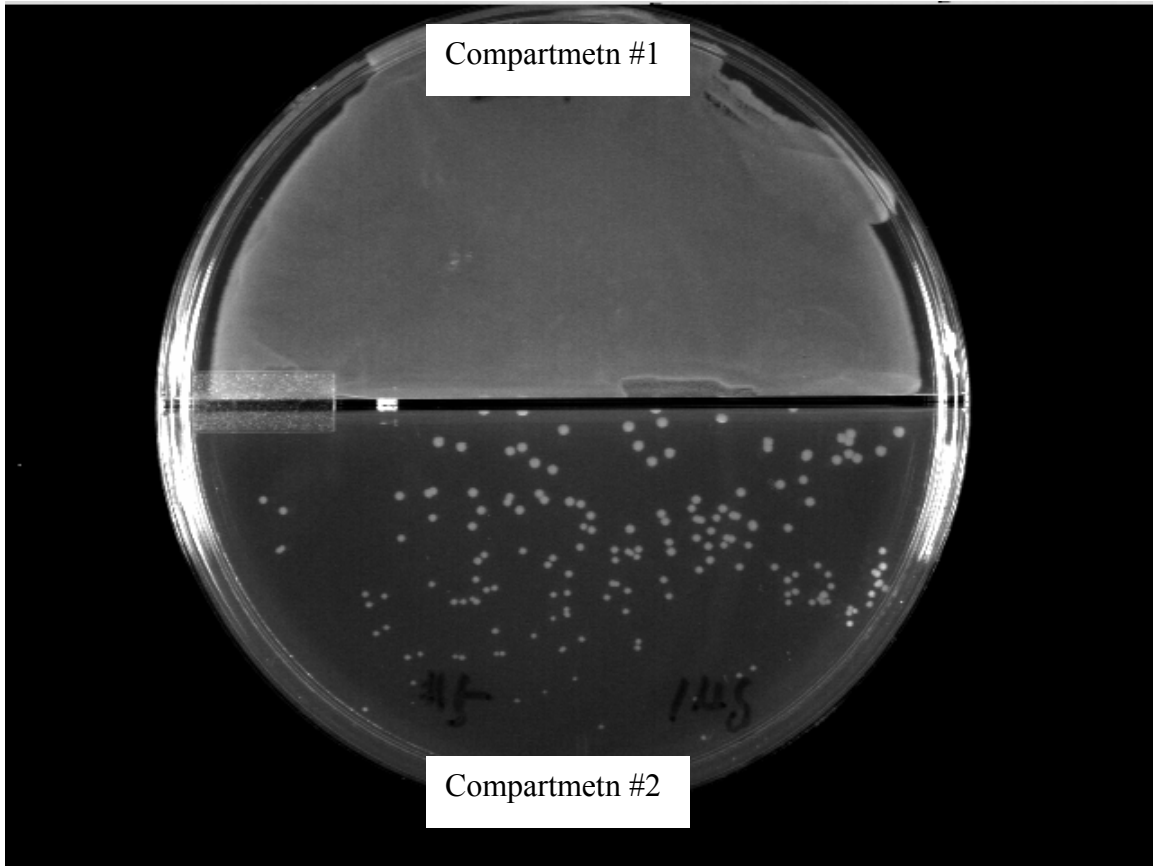
**Table 7.2.** Tetracycline tolerant sub-populations (CFU) in Tet<sup>s</sup> *E. coli* Isolate 5 when exposed to airborne quorum sensing molecules

Signaling Sample in Compartment # 1	<sup>a</sup> Tet <sup>s</sup> <i>E. coli</i> Isolate 5 (CFU)			
	Tetracycline concentration (µg/mL)			
	0	1	2	4
<sup>b</sup> Tet <sup>s</sup> <i>S. Newport</i>	251±54	134±23	32±18	0
	(100%) <sup>c</sup>	(53%)	(13%)	(0%)
Distilled water	251±54	0	0	0
	(100%)	(0%)	(0%)	(0%)

<sup>a</sup> Tet<sup>s</sup> *E. coli* Isolate 5 (tetracycline MIC < 1 µg/mL).

<sup>b</sup> Tet<sup>s</sup> *S. Newport* (tetracycline MIC < 1 µg/mL).

<sup>c</sup> Values in parenthesis represents % of colonies as compared to un-amended tetracycline plates.



**Fig. 7.2.** Morphology of induced colonies on tetracycline-supplemented agar by airborne quorum sensing molecules.

## DISCUSSION

The development of Tet<sup>s</sup> *E. coli* Isolate 5 and Tet<sup>s</sup> *S. Newport* colonies in physically separated Compartment # 2 (of the bi-partite plates) containing 1 to 4 µg/mL tetracycline suggests the possibility that an airborne signal from the “signaling population” is influencing the development of tetracycline tolerant colonies. The absence of growth when exposed to 8 µg/mL tetracycline rules out the possibility that these tetracycline-tolerant colonies were “carryover” cells from the signaling population. If they were “carryover” cells then they would have been resistant to as much as 128 µg/mL of tetracycline. Another line of evidence that the colonies that developed in Compartment # 2 were those that had developed tolerance rather than the carryover from the Tet<sup>r</sup> signaling population was their inability to express the resistance phenotype after subsequent transfer to a fresh medium.

To determine whether AI-2 molecules were involved in the airborne quorum sensing system, we used *E. coli* MDAI2 (*luxS*::Tc<sup>r</sup>) (which does not produce AI-2 because of insertion-causing mutation in the *luxS* gene) (DeLisa et al., 2001c) as the signaling population in Compartment # 1. Tet<sup>s</sup> *E. coli* Isolate 5 and Tet<sup>s</sup> *S. Newport* formed tetracycline-tolerant colonies on 1-4 µg/mL of tetracycline-supplemented agar (**Table 7.1**) suggesting that LuxS-dependent AI-2 molecule was probably not the autoinducer signal that was involved in this phenomenon. Further evidence that AI-2 molecules were not involved in the tolerance development could be deduced when CFS was used as the “signaling molecule” in Compartment # 1. No tetracycline –tolerant colonies formed among the Tet<sup>s</sup> *E. coli* or Tet<sup>s</sup> *S. Newport* isolates even at concentrations as low as 1 µg/mL (**Table 7.1**).

If we rule out the unlikely possibility that there was diffusion of autoinducer molecules through the plastic walls of the bi-partite plates, and given the existence of an air gap that connects Compartments # 1 and # 2, we can conclude that an airborne signal is probably present which induced *E. coli* and *S. Newport* to develop tolerance to sub-therapeutic levels of tetracycline. The presence of an airborne molecule that is possibly influencing the development of tetracycline tolerant cells is also supported by the inability of the Tet<sup>s</sup> cells to grow on tetracycline-amended media in conventional Petri plates (data not included). Heal and Parsons (2002) have previously shown that the ampicillin resistance that was influenced by an airborne molecule could be completely eliminated by a complete physical separation of Compartments # 1 and # 2 (which is analogous to growing the two populations in separate Petri dishes). In their studies (which reported the development of resistant mutants unlike our results where only tetracycline tolerance was observed), they were able to observe microbial growth only when the antibiotic was below the MIC of the susceptible population. In contrast, in our present study we observed colony formation in Compartment # 2 of bipartite plates that contained tetracycline at concentrations significantly greater than the MIC of the susceptible *E. coli* or *S. Newport* population. These differences may be attributable to the type of bacterial signals that are probably operating and secondly could be due to the strains that were employed in our respective studies. Heal and Parsons (2002) hypothesized that indole was the most likely signaling molecule and employed laboratory strains. In our studies, which involved wild-type *E. coli* and *S. Newport* strains, however, we observed airborne signaling even when the non-indole producing strain (*S. Newport*) was employed (**Table 7.1**).

The inability of the cells to form colonies in Compartment # 2 when the signaling populations and those in Compartment # 2 were plated at the same time suggested that the airborne molecules would have had to develop over the course of the 24-hour incubation after which they would have influenced the development of tetracycline tolerant colonies in Compartment # 2. Previous studies have also confirmed that the signaling population would only be able to “signal” only when they had reached stationary phase at which time the expression of  $\sigma^{38}$ , a subunit of RNA polymerase reached maximal concentrations (Heal and Parsons, 2002; Jishage et al., 1996).

In the current study, there is evidence for a non-indole based airborne signaling between the two different genera, *Escherichia* and *Salmonella*. When Tet<sup>s</sup> (indole-negative) *S. Newport* was used as the signaling population in Compartment # 1, it was capable of inducing the development of tetracycline-tolerant colonies in Tet<sup>s</sup> *E. coli* even up to 4 µg/mL of tetracycline (**Table 7.1**). These colonies on tetracycline-supplement agar exhibited morphological differences. Interestingly, those colonies close to the signaling populations or the plastic divider appeared normal, while those far from the divider were pinpoint colonies (**Fig. 7.2**). Approximately 53% and 13% of the Tet<sup>s</sup> *E. coli* Isolate 5 were recovered as tetracycline-tolerant colonies on 1 and 2 µg/mL of tetracycline-supplemented agar, respectively, as compared with negative control (**Table 7.1**). Tet<sup>s</sup> *S. Newport* formed tetracycline-tolerant colonies on 1-4 µg/mL of tetracycline-supplemented agar in the presence of either Tet<sup>r</sup> *E. coli* Isolate 1 or *E. coli* MDAI2 (*luxS::Tc<sup>r</sup>*) suggesting that AI-2 signals were not involved in the inter generic signaling . No colonies formed even on 1 µg/mL of tetracycline-supplemented agar in the absence of signaling populations (**Table 7.1**)

Overall, these results suggests that a yet-to-be identified and characterized non-indole, non AI-2- based signaling molecule(s) appears to be responsible for inducing *E. coli* tolerance to tetracycline. The ability to induce this tolerance seems to be distance dependent (based on the size of the colonies from the divider between the two populations). The ability of antibiotic sensitive populations to develop antibiotic-tolerant sub-populations can have ecological ramifications in terms of survival and ultimately acquisition of resistance determinants among pathogens and commensal organisms during antibiotic stress. The ecological relevance of airborne-based signaling should not be underestimated given the proximity in which microbial assemblages exist in natural and man-made environments. The possibility of airborne signaling in the development of antibiotic tolerance may be relevant in environments such as hospitals and concentrated animal feeding or rearing operations where the issues of antibiotic resistance development and dissemination are of concern. We are currently attempting to understand the physiological and genetic changes occurring in the antibiotic-sensitive and tolerant cells as a result of exposure to these airborne signaling molecules.

## CHAPTER VIII

### SUMMARY

Quorum sensing is a cell density-dependent process for regulation of gene expression in bacteria. A number of environmental factors have been shown to affect AI-2-based quorum sensing response in *E. coli*. The universal signal AI-2 appears to be widespread in both Gram-positive and Gram-negative bacteria, and appears to control the expression of hundreds of genes in *E. coli*. Laboratory studies were conducted to understand the relationship between exposure of sub-therapeutic concentrations of the antibiotic tetracycline and quorum sensing responses in *E. coli*. Limited *in vivo* studies to understand AI-2 activity within the ceca of poultry chicks in response to sub-therapeutic concentrations of selected antibiotics were also conducted. Understanding the relationship between sub-therapeutic tetracycline exposure, AI-2-based quorum sensing response and the development of tetracycline resistance in *E. coli* could provide a potential approach to reducing the emergence of tetracycline resistance. Additionally, a selected number of studies were conducted to determine the levels of autoinducer 2 (AI-2)-like Activity associated with Foods and its Interaction with Food Additives. The results from these studies are summarized below:

#### **AUTOINDUCER 2-BASED RESPONSE INDUCES TETRACYCLINE TOLERANCE IN ESCHERICHIA COLI UNDER SUB-THERAPEUTIC EXPOSURE**

All three *E. coli* isolates (two tetracycline-resistant and 1 tetracycline-sensitive isolates) produced AI-2, however, they had different pattern of AI-2 activities in response to sub-therapeutic tetracycline exposure. In the presence of tetracycline, the Tet<sup>s</sup> *E. coli*

strain continued to have increasing AI-2 activity even after 20 hours of exposure to the antibiotic (2 µg/mL). Results indicate that AI-2 actually enhances the ability of the Tet<sup>s</sup> *E. coli* strain to survive sub-therapeutic tetracycline (10 µg/mL) stress. About 87% of the Tet<sup>s</sup> *E. coli* strain survived 4 hours of exposure to chlortetracycline in LB plus 80% cell-free supernatant (AI-2<sup>+</sup>). After 20 hours of exposure, the 69% survival rate of the Tet<sup>s</sup> strain was still significantly higher (P<0.05) than in the control treatments. There was, however, no difference between the survival of the Tet<sup>s</sup> strain when exposed to only 20% cell-free supernatant (AI-2<sup>+</sup>). The enhanced AI-2 activity can protect the cells from tetracycline stress and lead to the development of tetracycline-tolerant sub-populations.

#### **AUTOINDUCER AI-2 ACTIVITY IN RESPONSE TO SUB-THERAPEUTIC ANTIBIOTIC EXPOSURE IN ENTERIC BACTERIA**

When the *E. coli* cells were in a steady state (under continuous culture conditions) at 24 h, AI-2 activity remained stable albeit at only a 20-fold increase over baseline conditions. When the *E. coli* cells under steady state conditions were exposed to tetracycline at sub-therapeutic concentrations (2 µg/ml), the results indicate increasing AI-2 activity in response to increasing levels of tetracycline. The probiotic CF3 culture, however, did not exhibit any AI-2 activity in VL medium in the presence or absence of sub-therapeutic levels of tetracycline. *In vivo* studies conducted in the cecum of poultry chicks demonstrate that though AI-2 activity increased initially in the presence of vancomycin, there was no significant increase in AI-2 activity in the presence of tetracycline or tylosin. Detectable levels of AI-2 activity are not evident within the



chicken cecum based on the response observed in the *in vitro* studies conducted with the probiotic CF3 culture, or *in vivo* within the chicken cecum.

### **AI-2-BASED QUORUM SENSING PROMOTES *trbC* GENE EXPRESSION AND CONJUGAL TRANSFER OF *tet(A)* GENE IN RESPONSE TO SUB-THERAPEUTIC TETRACYCLINE EXPOSURE IN *ESCHERICHIA COLI***

The transfer frequency (based on donor population) was  $3.5 \times 10^{-5}$  -  $3.3 \times 10^{-6}$  when donors exposed to AI-2 singals in comparison to  $5.4 \times 10^{-7}$  -  $5.5 \times 10^{-7}$  and  $2.0 \times 10^{-6}$  -  $4.5 \times 10^{-7}$  as observed in the negative controls (AI-2 negative samples and LB medium, respectively). Gene expression studies performed using real-time PCR analysis indicated that the pilin-encoding *trbC* gene mRNA levels increased 3.2-fold when exposed to AI-2 molecules, and up to 9.0-fold in cells when exposed to AI-2 molecules plus sub-therapeutic tetracycline for 30 minutes. The relaxase-encoding *traI* gene mRNA levels, however, were regulated by 0.2-fold (in the presence of AI-2) and 0.6-fold (in the presence of AI-2 and sub-therapeutic tetracycline). AI-2-based quorum sensing can thus affect the transcription of at least one conjugation-associated gene (*trbC*) and also enhance conjugation transfer frequency of plasmid RP4 carrying *tet(A)* among *E. coli* strains.

### **AUTOINDUCER 2 (AI-2)-LIKE ACTIVITY ASSOCIATED WITH FOODS AND ITS INTERACTION WITH ORGANIC ACIDS USED AS FOOD**

Maximum AI-2 activity was seen on frozen fish sample (203-fold as compared to the negative control) followed by tomato (121 fold), cantaloupe (58-fold), carrots (56-

fold), tofu (29-fold) and milk samples (7- and 4-fold). Interestingly, some samples were capable of inhibiting AI-2 activity. Turkey patties showed the highest inhibition (99.8% compared to the positive control) followed by chicken breast (97.5%), homemade cheeses (93.7%), beef steak (90.6%) and beef patties (84.4%). AI-2 activity was almost totally inhibited by sodium propionate while sodium benzoate caused a 93.3% inhibition as compared to 75% inhibition by sodium acetate. Sodium nitrate did not have any appreciable effect even at 200 ppm.

#### **A NON-INDOLE-BASED AIRBORNE QUORUM SENSING MOLECULE CAN CONFER TETRACYCLINE TOLERANCE IN PHYSICALLY SEPARATED *ESCHERICHIA COLI* AND *SALMONELLA* NEWPORT**

Using bi-partite Petri plates, induction of tolerance to tetracycline was observed in Tet<sup>s</sup> *E. coli* and Tet<sup>s</sup> *S. Newport* when either *E. coli*, or *S. Newport*, or *E. coli* MDAI2 (*luxS::Tc<sup>r</sup>*) was used as the signaling population. However, no tolerance induction was observed in Tet<sup>s</sup> *E. coli* or Tet<sup>s</sup> *S. Newport* when cell-free supernatants (CFS) were used as the signaling molecule. Induced colonies exhibited morphological differences on tetracycline-supplemented agar. A non-indole, non AI-1 and non-AI-2 based quorum sensing system thus also exists for communication between *E. coli* and *S. Newport* through an airborne molecule.

## CHAPTER IX

### CONCLUSIONS

1. Natural isolates of *E. coli* produce AI-2 in the presence or absence of sub-therapeutic antibiotic stresses. These results provide evidence that subjecting a Tet<sup>s</sup> *E. coli* strain to sub-therapeutic tetracycline exposure will enhance AI-2 activity in these cells. The enhanced AI-2 activity can protect the cells from tetracycline stresses and lead to the development of tetracycline-tolerant cells, which may provide for genetic transfer events.
2. AI-2 molecules (a key signal in bacterial quorum sensing) are presented though transiently within the microbial consortia in the ceca of young chicks. AI-2 activity can increase within these consortia depending on the type antibiotic that is administered.
3. AI-2 molecules enhance the transcription of *trbC* (at least one gene) and also enhance conjugal transfer frequency of plasmid RP4 carrying *tet(A)* among *E. coli* strains.
4. Certain vegetable produce, foods and food ingredients have elevated levels or reduced levels of AI-2 activity or, in some case can inhibit AI-2 activity.
5. A non-indole, non AI-2-based airborne signaling molecule(s) appears to be capable of inducing *E. coli* tolerance to tetracycline. The ability to induce this tolerance seems to be distance dependent (based on the size of the colonies from the divider between the two populations).

## REFERENCES

- Ahmer, B. M., van Reeuwijk, J., Timmers, C. D., Valentine, P. J., and Heffron, F. F. (1998) *Salmonella* Typhimurium encodes an SdiA homolog, a putative quorum sensor of the LuxR family, that regulates genes on the virulence plasmid. *J. Bacteriol.* **180**: 1185-1193.
- Al-Ahmad, A., Daschner, F. D., and Kummerer, K. (1999) Biodegradability of cefotiam, ciprofloxacin, meropenem, penicillin G, and sulfamethoxazole and inhibition of waste water bacteria. *Arch. Environ. Contam. Toxicol.* **37**:158-163.
- Alloing, G., Granadel, C., Morrison, D. A., and Claverys, J. P. (1996) Competence pheromone, oligopeptide permease, and induction of competence in *Streptococcus pneumoniae*. *Mol. Microbiol.* **21**:471-478.
- Alloing, G., Martin, B., Granadel, C., and Claverys, J. P. (1998) Development of competence in *Streptococcus pneumoniae*: pheromone autoinduction and control of quorum sensing by the oligopeptide permease. *Mol. Microbiol.* **29**:75-83.
- Animal Health Institute. (2003) Survey shows stable antibiotic usage in animals. <http://www.ahi.org/mediacenter/documents/NRAntibioticUse2002.pdf>.
- Arnold, C. N., McElhanon, J., Lee, A., Leonhart, R., and Siegele, D. A. (2001) Global analysis of *Escherichia coli* gene expression during the acetate-induced acid tolerance response. *J. Bacteriol.* **183**: 2178-2186.
- Bahl, M. I., Sorensen, S. J., Hansen, L. H., and Licht, T. R. (2004) Effect of tetracycline on transfer and establishment of the tetracycline-inducible conjugative transposon Tn916 in the guts of gnotobiotic rats. *Appl. Environ. Microbiol.* **70**:758-764.
- Bainton, N. J., Bycroft, B. W., Chhabra, S. R., Stead, P., Gledhill, L., Hill, P. J., Rees, C. E., Winson, M. K., Salmond, G. P., and Stewart, G. S. (1992) A general role for the *lux* autoinducer in bacterial cell signaling: control of antibiotic biosynthesis in *Erwinia*. *Gene* **116**:87-91.
- Bassler, B. L. (1999) How bacteria talk to each other: regulation of gene expression by quorum sensing. *Curr. Opin. Microbiol.* **2**:582-587.
- Bassler, B. L. (2002) Small talk. Cell-to-cell communication in bacteria. *Cell* **109**:421-424.
- Bassler, B. L., Greenberg, E. P., and Stevens, A. M. (1997) Cross-species induction of luminescence in the quorum-sensing bacterium *Vibrio harveyi*. *J. Bacteriol.* **179**: 4043-4045.

- Bassler, B. L., Wright, M., Showalter, R. E., and Silverman, M. R. (1993) Intercellular signaling in *Vibrio harveyi*: sequence and function of genes regulating expression of luminescence. *Mol. Microbiol.* **9**:773-786.
- Bassler, B. L., Wright, M., and Silverman, M. R. (1994) Multiple signaling systems controlling expression of luminescence in *Vibrio harveyi* sequence and function of genes encoding a second sensory pathway. *Mol. Microbiol.* **13**:273-286.
- Bauer, W. D., and Robinson, J. B. (2002) Disruption of bacterial quorum sensing by other organisms. *Curr. Opin. Biotech.* **13**:234-237.
- Beeston, A. L., and Surette, M. G. (2002) *pfs*-dependent regulation of autoinducer 2 production in *Salmonella enterica* serovar Typhimurium. *J. Bacteriol.* **184**:3450-3456.
- Berry, E. D., and Cutter, C. N. (2000) Effects of acid adaptation of *Escherichia coli* O157:H7 on efficacy of acetic acid spray washes to decontaminate beef carcass tissue. *Appl. Environ. Microbiol.* **66**:1493-1498.
- Beuchat, L. R., and Ryu, J. H. (1997) Produce handling and processing practices. *Emerg. Infect. Dis.* **3**:459-465.
- Blake, D. P., Hillman, K., Fenlon, D. R., and Low, J. C. (2003a) Transfer of antibiotic resistance between commensal and pathogenic members of the *Enterobacteriaceae* under ileal conditions. *J. Appl. Microbiol.* **95**:428-436.
- Blake, D. P., Humphry, R. W., Scott, K. P., Hillman, K., Fenlon, D. R., and Low, J. C. (2003b) Influence of tetracycline exposure on tetracycline resistance and the carriage of tetracycline resistance genes within commensal *Escherichia coli* population. *J. Appl. Microbiol.* **94**:1087-1097.
- Blattner, F. R., Plunkett, G., 3<sup>rd</sup>, Bloch, C. A., Perna, N. T., Burland, V., Riley, M., Collado-Vides, J., Glasner, J. D., Rode, C. K., Mayhew, G. F., Gregor, J., Davis, N. W., Kirkpatrick, H. A., Goeden, M. A., Rose, D. J., Mau, B., and Shao, Y. (1997) The complete genome sequence of *Escherichia coli* K-12. *Science* **277**:1453-1474.
- Blehert, D. S., Palmer, R. J., Jr., Xavier, J. B., Almeida, J. S., and Kolenbrader, P. E. (2003) Autoinducer 2 production by *Streptococcus gordonii* DL1 and the biofilm phenotype of a *luxS* mutant are influenced by nutritional conditions. *J. Bacteriol.* **185**:4851-4860.
- Bollinger, N., Hassett, D. J., Iglewski, B. H., Costerton, J. W., and McDermott, T. R. (2001) Gene expression in *Pseudomonas aeruginosa*: evidence of iron override effects on quorum sensing and biofilm-specific gene regulation. *J. Bacteriol.* **183**:1990-1996.

Briggs, C. E., and Fratamico, P. M. (1999) Molecular characterization of an antibiotic resistance gene cluster of *Salmonella* Typhimurium DT104. *Antimicrob. Agents Chemother.* **43**:846-849.

Byers, J. T., Lucas, C., Salmond, G. P., and Welch, M. (2002) Nonenzymatic turnover of an *Erwinia carotovora* quorum-sensing signaling molecule. *J. Bacteriol.* **184**:1163-1171.

Cadioux, N., Bradbeer, C., Reeger-Schneider, E., Koster, W., Mohanty, A. K., Wiener, M. C., and Kadner, R. J. (2002) Identification of the periplasmic cobalamin-binding protein BtuF of *Escherichia coli*. *J. Bacteriol.* **184**:706-717.

Camara, M., Williams, P., and Hardman, A. (2002) Controlling infection by tuning in and turning down the volume of bacterial small-talk. *Lancet Infect. Dis.* **2**:667-676.

Casewell, M., Friis, C., Marco, E., McMullin, P., and Phillips, I. (2003) The European ban on growth-promoting antibiotics and emerging consequences for human and animal health. *J. Antimicrob. Chemother.* **52**:159-161.

Chen, X., Schauder, S., Potier, N., Van Dorsselaer, A., Pelczer, I., Bassler, B. L., and Hughson, F. M. (2002) Structural identification of a bacterial quorum-sensing signal containing boron. *Nature* **415**:545-549.

Chopra, I., Hawkey, P. M., and Hinton, M. (1992) Tetracyclines, molecular and clinical aspects. *J. Antimicrob. Chemother.* **29**:245-277.

Chopra, I., and Roberts, M. (2001) Tetracycline antibiotics: mode of action, applications, molecular biology, and epidemiology of bacterial resistance. *Microbiol. Mol. Biol. Rev.* **65**:232-260.

Cloak, O. M., Solow, B. T., Briggs, C. E., Chen, C. Y., and Fratamico, P. M. (2002) Quorum sensing and production of autoinducer-2 in *Campylobacter* spp., *Escherichia coli* O157:H7, and *Salmonella enterica* serovar Typhimurium in foods. *Appl. Environ. Microbiol.* **68**:4666-4671.

Committee on Drug Use in Food Animals. (1999) *The Use of Drugs in Food Animals: Benefits and Risks*. Washington, DC: National Academy Press.

Corrier, D. E., Nisbet, D. J., Scanlan, C. M., Hollister, A. G., and Deloach, J. R. (1995) Control of *Salmonella* Typhimurium colonization in broiler chicks with a continuous-flow characterized mixed culture of cecal bacteria. *Poult. Sci.* **74**:916-924.

Coulthurst, S. J., Whitehead, N. A., Welch, M., and Salmond, G. P. (2002) Can boron get bacteria talking? *Trends Biochem. Sci.* **27**:217-219.

- D'Aoust, J. Y. (1985) Infective dose of *Salmonella* Typhimurium in cheddar cheese. *Am. J. Epidemiol.* **122**:717-720.
- Davidson, P. M., and Harrison, M. A. (2002) Resistance and adaptation to food antimicrobial sanitizers, and other process controls. *Food Tech.* **56**:69-78.
- Davies, D. G., Parsek, M. R., Pearson, J. P., Iglewski, B. H., Costerton, J. W., and Greenberg, E. P. (1998) The involvement of cell-to-cell signals in the development of a bacterial biofilm. *Science* **280**:295-198.
- Day, W. A., Jr., and Maurelli, A. T. (2001) *Shigella flexneri* LuxS quorum sensing system modulates *virB* expression but is not essential for virulence. *Infect. Immun.* **69**:15-23.
- DeLisa, M. P., Valdes, J. J., and Bentley, W. E. (2001a) Quorum sensing via AI-2 communicates the "metabolic burden" associated with heterologous protein production in *Escherichia coli*. *Biotechnol. Bioeng.* **75**:439-450.
- DeLisa, M. P., Valdes, J. J., and Bentley, W. E. (2001b) Mapping stress-induced changes in autoinducer AI-2 production in chemostat-cultivate *Escherichia coli* K-12. *J. Bacteriol.* **183**:2918-2928.
- DeLisa, M. P., Wu, C. F., Wang, L., Valdes, J. J., and Bentley, W. E. (2001c) DNA microarray-based identification of genes controlled by autoinducer 2-stimulated quorum sensing in *Escherichia coli*. *J. Bacteriol.* **183**:5239-5247.
- Derzelle, S., Duchaud, E., Kunst, F., Danchin, A., and Bertin, P. (2002) Identification, characterization, and regulation of a cluster of genes involved in carbapenem biosynthesis in *Photobacterium luminescens*. *Appl. Environ. Microbiol.* **68**:3780-3789.
- Dong, Y. H., Wang, L. H., Xu, J. L., Zhang, H. B., Zhang, X. F., and Zhang, L. H. (2001) Quenching quorum-sensing-dependent bacterial infection by an *N*-acyl-homoserine lactonase. *Nature* **411**:813-817.
- Dong, Y. H., Xu, J. L., Li, X. Z., and Zhang, L. H. (2000) AiiA, an enzyme that inactivates the acylhomoserine lactone quorum-sensing signal and attenuates the virulence of *Erwinia carotovora*. *Proc. Natl. Acad. Sci. USA* **97**:3526-3531.
- Duan, K., Dammel, C., Stein, J., Rabin, H., and Surette, M. G. (2003) Modulation of *Pseudomonas aeruginosa* gene expression by host microflora through interspecies communication. *Mol. Microbiol.* **50**:1477-1491.
- Eisenbrandt, R., Kalkum, M., Lai, E. M., Lurz, R., Kado, C. I., and Lanka, E. (1999) Conjugative pili of IncP plasmids, and the Ti plasmid T pilus are composed of cyclic subunits. *J. Biol. Chem.* **274**:22548-22555.

- Elvers, K. T., and Park, S. F. (2002) Quorum sensing in *Campylobacter jejuni*: detection of a *luxS* encoded signaling molecule. *Microbiology* **148**:1475-1481.
- Endley, S., Johnson, E., and Pillai, S. D. (2003) A simple method to screen cilantro and parsley for fecal indicator viruses. *J. Food Prot.* **66**:1506-1509.
- Endley, S., Lu, L., Vega, E., Hume, M. E., and Pillai, S. D. (2003) Male-specific coliphages as an additional fecal contamination indicator for screening fresh carrots. *J. Food Prot.* **66**:88-93.
- Erickson, D. L., Nsereko, V. L., Morgavi, D. P., Selinger, L. B., Rode, L. M., and Beauchemin, K. A. (2002) Evidence of quorum sensing in the rumen ecosystem: detection of N-acyl homoserine lactone autoinducers in ruminal contents. *Can. J. Microbiol.* **48**:374-378.
- Evans, K., Passador, L., Srikumar, R., Tsang, E., Nezezon, J., and Poole, K. (1998) Influence of the MexAB-OprM multidrug efflux system on quorum sensing in *Pseudomonas aeruginosa*. *J. Bacteriol.* **180**:5443-5447.
- Fernandez-Astorga, A., Muela, A., Cisterna, R., Irberri, J., and Barcina, I. (1992) Biotic and abiotic factors affecting plasmid transfer in *Escherichia coli* strains. *Appl. Environ. Microbiol.* **58**:392-398.
- Fray, R. G. (2002) Altering plant-microbe interaction through artificially manipulating bacterial quorum sensing. *Ann. Botany* **89**:245-253
- Freeman, J. A., and Bassler, B. L. (1999) A genetic analysis of the function of LuxO, a two-component response regulator involved in quorum sensing in *Vibrio harveyi*. *Mol. Microbiol.* **31**: 665-677.
- Gao, M., Teplitski, M., Robinson, J. B., and Bauer, W. D. (2003) Production of substances by *Medicago truncatula* that affect bacterial quorum sensing. *Mol. Plant Microbe Interact.* **16**:827-834.
- Gawande, P. V., and Bhagwat, A. A. (2002) Inoculation onto solid surface protects *Salmonella* spp. during acid challenge: a model study using polyethersulfone membranes. *Appl. Environ. Microbiol.* **68**:86-92.
- Ghigo, J. M. (2001) Natural conjugative plasmids induce bacterial biofilm development. *Nature* **412**:442-445.
- Givskov, M., DeNys, R., Manefield, M., Gram, L., Maximilien, R., Eberl, L., Molin, S., Steinberg, P. D., and Kjelleberg, S. (1996) Eukaryotic interference with homoserine lactone-mediated prokaryotic signaling. *J. Bacteriol.* **178**:6618-6622.



Grossman, A. D. (1995) Genetic networks controlling the initiation of sporulation and the development of genetic competence in *Bacillus subtilis*. *Annu. Rev. Genet.* **29**:477-508.

Guo, X., Chen, J., Brackett, R. E., and Beuchat, L. R. (2001) Survival of *Salmonellae* on and in tomato plants from the time of inoculation at flowering and early stages of fruit development through fruit ripening. *Appl. Environ. Microbiol.* **67**:4760-4764.

Guo, X., Chen, J., Brackett, R. E., and Beuchat, L. R. (2002) Survival of *Salmonella* on tomatoes stored at high relative humidity, in soil, and on tomatoes in contact with soil. *J. Food Prot.* **65**:274-279.

Gustafson, R. H., and Kiser, J. S. (1985) Nonmedical uses of the tetracyclines. In J. J. Hlavka and J. H. Boothe (ed.), *Handbook of Experimental Pharmacology*, vol. 78. Berlin, Germany: Springer-Verlag KG. pp 405-446.

Haase, J., Lurz, R., Grahn, A. M., Bamford, D. H., and Lanka, E. (1995) Bacterial conjugation mediated by plasmid RP4: RSF1010 mobilization, donor-specific phage propagation, and pilus production require the same Tra2 core components of a proposed DNA transport complex. *J. Bacteriol.* **177**:4779-4791.

Hammer, B. K., and Bassler, B. L. (2003) Quorum sensing controls biofilm formation in *Vibrio cholerae*. *Mol. Microbiol.* **50**:101-114.

Hardie, K. R., Cooksley, C., Green, A. D., and Winzer, K. (2003) Autoinducer 2 activity in *Escherichia coli* culture supernatants can be actively reduced despite maintenance of an active synthase, LuxS. *Microbiology* **149**:715-728.

Hartman, A. B., Essiet, I. I., Isenbarger, D. W., and Lindler, L. E. (2003) Epidemiology of tetracycline resistance determinants in *Shigella* spp. and enteroinvasive *Escherichia coli*: characterization and dissemination of *tet(A)*-1. *J. Clin. Microbiol.* **43**:1023-1032.

Havarstein, L. S., Coomaraswamy, G., and Morrison, D. A. (1995) An unmodified heptadecapeptide pheromone induces competence for genetic transformation in *Streptococcus pneumoniae*. *Proc. Natl. Acad. Sci. USA* **92**:11140-11144.

He, X., Chang, W., Pierce, D. L., Seib, L. O., Wagner, J., and Fuqua, C. (2003) Quorum sensing in *Rhizobium* sp. strain NGR234 regulates conjugal transfer (*tra*) gene expression and influences growth rate. *J. Bacteriol.* **185**:809-822.

Heal, R. D., and Parsons, A. T. (2002) Novel intercellular communication system in *Escherichia coli* that confer antibiotic resistance between physically separated populations. *J. Appl. Microbiol.* **92**:1116-1122.

Hengge-Aronis, R. (1999) Interplay of global regulators and cell physiology in the general stress response of *Escherichia coli*. *Curr. Opin. Microbiol.* **2**:148-52.

Hentzer, M., Wu, H., Andersen, J. B., Riedel, K., Rasmussen, T. B., Bagge, N., Kumar, N., Schembri, M. A., Song, Z., Kristoffersen, P., Manefield, M., Costerton, J. W., Molin, S., Eberl, L., Steinberg, P., Kjelleberg, S., Hoiby, S., and Givskov, M. (2003) Attenuation of *Pseudomonas aeruginosa* virulence by quorum sensing inhibitors. *EMBO J.* **22**:3803-3815.

Holden, M. T.G., Ram Chhabra, S., de Nys, R., Manefield, M., Kumar, N., Labatte, M., England, D., Rice, S., Givskov, M., Salmond, G. P. C., Bycroft, B. W., Kjelleberg, S., and Williams, P. (1999) Quorum-sensing cross talk: isolation and chemical characterization of cyclic dipeptides from *Pseudomonas aeruginosa* and other Gram-negative bacteria. *Mol. Microbiol.* **33**:1254-1266.

Holmberg, S. D., Wells, J. G., and Cohen, M. L. (1984) Animal-to-man transmission of antimicrobial-resistant *Salmonella*: investigations of U. S. outbreaks 1971-1983. *Science* **225**:833-835.

Huges, P., and Heritage, J. (2002) Antibiotic growth-promoters in food animals. *Agriippa*. [http://www.fao.org/docrep/article/agriippa/555\\_en.htm](http://www.fao.org/docrep/article/agriippa/555_en.htm).

Hume, M. E., Byrd, J. A., Stanker, L. H., and Ziprin, R. L. (1998b) Reduction of caecal *Listeria monocytogenes* in Leghorn chicks following treatment with a competitive exclusion culture (PREEMPT). *Lett. Appl. Microbiol.* **26**:432-436.

Hume, M. E., Corrier, D. E., Nisbet, D. J., and DeLoach, J. R. (1998a) Early *Salmonella* challenge time and reduction in chick cecal colonization following treatment with a characterized competitive exclusion culture. *J. Food Prot.* **61**:673-676.

Hume, M. E., Hollister, A. G., Nisbet, D. J., Corrier, D. E., and DeLoach, J. R. (1996) Effect of a characterized continuous-flow culture of cecal bacteria on *Salmonella* Typhimurium crop colonization in broiler chicks. *Avian Dis.* **40**:391-397.

Hume, M. E., Nisbet, D. J., and DeLoach, J. R. (1997) In vitro <sup>14</sup>C-amino acid fermentation by CF3, a characterized continuous-flow competitive exclusion culture of caecal bacteria. *J. Appl. Microbiol.* **83**:236-242.

Huys, G., D'Haene, K., Collard, J. M., and Swings, J. (2004). Prevalence and molecular characterization of tetracycline resistance in *Enterococcus* isolates from food. *Appl. Environ. Microbiol.* **70**:1555-1562.

Iida, A., Harayama, S., Lino, T., and Hazelbauer, G. L. (1984) Molecular cloning and characterization of genes required for ribose transport and utilization in *Escherichia coli* K-12. *J. Bacteriol.* **158**:674-682.

Institute of Medicine, Division of Health Promotion and Disease Prevention. (1998) Report of a study. *Human Health Risks with the Subtherapeutic Use of Penicillin or Tetracyclines in Animal Feed*. Washington, DC: National Academy Press.

Itoh, Y., Sugita-Konishi, Y., Kasuga, F., Iwaki, M., Hara-Kudo, Y., Saito, N., Noguchi, Y., Konuma, H., and Kumagai, S. (1998) Enterohemorrhagic *Escherichia coli* O157:H7 present in radish sprouts. *Appl. Environ. Microbiol.* **64**:1532-1535.

Jagura-Burdzy, G., Ibbotson, J. P., and Thomas, C. M. (1991) The *korF* region of broad-host-range plasmid RK2 encodes two polypeptides with transcriptional repressor activity. *J. Bacteriol.* **173**:826-833.

Jay, J. M. (2000a) Seafood. In J. M. Jay (ed.), *Modern Food Microbiology*. 6<sup>th</sup> ed. Gaithersburg, MD: Aspen Publishers, Inc., pp 101-105.

Jay, J. M. (2000b) Food preservation with chemicals. In J. M. Jay (ed.), *Modern Food Microbiology*. 6<sup>th</sup> ed. Gaithersburg, MD: Aspen Publishers, Inc., pp 253-275.

Jay, J. M., Vilai, J. P., and Hughes, M. E. (2003) Profile and activity of the bacterial biota of ground beef held from freshness to spoilage at 5-7 degrees C. *Int. J. Food Microbiol.* **81**:105-111.

Jiang, Y., Camara, M., Chhabra, S. R., Hardie, K. R., Bycroft, B. W., Lazdunski, A., Salmond, G. P. C., Stewart, G. S. A. B., and Williams, P. (1998). *In vitro* biosynthesis of the *Pseudomonas aeruginosa* quorum-sensing signal molecule N-butanoyl-L-homoserine lactone. *Mol. Microbiol.* **28**:193-203.

Jishage, M., Iwata, A., Ueda, S., and Ishihama, A. (1996) Regulation of RNA polymerase sigma subunit synthesis in *Escherichia coli*: intracellular levels of four species of sigma subunit under various growth conditions. *J. Bacteriol.* **178**:5447-5451.

Jones, M. B., and Blaser, M. J. (2003). Detection of a *luxS*-signaling molecule in *Bacillus anthracis*. *Infect. Immun.* **71**:3914-3919.

Joyce, E. A., Bassler, B. L., and Wright, A. (2000) Evidence for a signaling system in *Helicobacter pylori*: detection of a *luxS*-encoded autoinducer. *J. Bacteriol.* **182**:3638-3643.

Jude, F., Kohler, T., Branny, P., Perron, K., Meyer, M. P., Comte, R., and van Delden, C. (2003) Posttranscriptional control of quorum-sensing-dependent virulence genes by DksA in *Pseudomonas aeruginosa*. *J. Bacteriol.* **185**:3558-3566.

Kanamaru, K., Kanamaru, K., Tatsuno, I., Tobe T., and Sasakawa, C. (2000) SdiA, an *Escherichia coli* homologues of quorum-sensing regulators, controls the expression

- of virulence factors in enterohemorrhagic *Escherichia coli* O157:H7. *Mol. Microbiol.* **38**:805-816.
- Khachatourians, G. G. (1998) Agricultural use of antibiotics and the evolution and transfer of antibiotic-resistance bacteria. *Can. Med. Association J.* **159**:1129-1136.
- Khachatryan, A. R., Hancock, D. D., Besser, T. E., and Call, D. R. (2004) Role of calf-adapted *Escherichia coli* in maintenance of antimicrobial drug resistance in dairy calves. *Appl. Environ. Microbiol.* **70**:752-757.
- Kim, W., and Surette, M. G. (2003) Swarming populations of *Salmonella* represent a unique physiological state coupled to multiple mechanisms of antibiotic resistance. *Biol. Proced. Online* **5**:189-196.
- Kirkpatrick, C., Maurer, L. M., Oyelakin, N. E., Yoncheva, Y. N., Maurer, R., and Slonczewski, J. L. (2001) Acetate and formate stress: opposite responses in the proteome of *Escherichia coli*. *J. Bacteriol.* **183**:6466-6477.
- Koetje, E. J., Hajdo-Milasinovic, A., Kiewiet, R., Bron, S., and Tjalsma, H. (2003) A plasmid-borne Rap-Phr system of *Bacillus subtilis* can mediate cell-density controlled production of extracellular proteases. *Microbiology* **149**:19-28.
- Kornacki, J. A., Chang, C. H., and Figurski, D. H. (1993) *kil-kor* regulon of promiscuous plasmid RK2: structure, products, and regulation of two operons that constitute the *kilE* locus. *J. Bacteriol.* **175**:5078-5090
- Krishnan, S., Rajan, D. P., and Ramakrishna, B. S. (1998) The ability of enteric diarrhoeal pathogens to ferment starch to short-chain fatty acids *in vitro*. *Scand. J. Gastroenterol.* **33**:242-246.
- Kwon, Y. M., and Ricke, S. C. (1998) Induction of acid resistance of *Salmonella* Typhimurium by exposure to short-chain fatty acids. *Appl. Environ. Microbiol.* **64**:3458-3463.
- Lawhon, S. D., Maurer, R., Suyemoto, M., and Altier, C. (2002) Intestinal short-chain fatty acids alter *Salmonella* Typhimurium invasion gene expression and virulence through BarA/SirA. *Mol. Microbiol.* **46**:1451-1464.
- Lazazzera, B. A. (2000) Quorum sensing and starvation: signals for entry into stationary phase. *Curr. Opin. Microbiol.* **3**:177-182
- Lazazzera, B. A., Solomon, J. M., and Grossman, A. D. (1997) An exported peptide functions intracellularly to contribute to cell density signaling in *B. subtilis*. *Cell* **89**:917-925.

- Lee, M. S., and Morrison, D. A. (1999) Identification of a new regulator in *Streptococcus pneumoniae* linking quorum sensing to competence for genetic transformation. *J. Bacteriol.* **181**:5004-5016.
- Lessl, M., Balzer, D., Lurz, R., Waters, V. L., Guiney, D. G., and Lanka, E. (1992a) Dissection of IncP conjugative plasmid transfer: definition of the transfer region Tra2 by mobilization of the Tra1 region in trans. *J. Bacteriol.* **174**:2493-2500.
- Lessl, M., Balzer, D., Pansegrau, W., and Lanka, E. (1992b) Sequence similarities between the RP4 Tra2 and the Ti VirB region strongly support the conjugation model for T-DNA transfer. *J. Biol. Chem.* **267**:20471-20480.
- Lessl, M., Balzer, D., Weyrauch, K., and Lanka, E. (1993) The mating pair formation system of plasmid RP4 defined by RSF1010 mobilization and donor-specific phage propagation. *J. Bacteriol.* **175**:6415-6425.
- Levy, S. B. (1986) Antibiotic resistance genes: ecology, transfer and expression, In Levy, S. B., and R. P. Novick (ed.). *Ecology of Antibiotic Resistance Determinants*. New York: Cold Spring Harbor Lab Press, pp 17-30.
- Leyer, G. J., Wang, L. L., and Johnson, E. A. (1995) Acid adaptation of *Escherichia coli* O157:H7 increases survival in acidic foods. *Appl. Environ. Microbiol.* **61**:3752-3755.
- Lina, G., Jarraud, S., Ji, G., Greenland, T., Pedraza, A., Eitenne, J., Novick, R. P., and Vandenesch, F. (1998) Transmembrane topology and histidine protein kinase activity of AgrC, the *agr* signal receptor in *Staphylococcus aureus*. *Mol. Microbiol.* **28**:655-662.
- Lithgow, J. K., Wilkinson, A., Rodelas, B., Wisniewski-Dye, F., Williams, P., and Downie, J. A. (2000) The regulatory locus *cinRI* in *Rhizobium leguminosarum* controls a network of quorum-sensing loci. *Mol. Microbiol.* **37**:81-97.
- Loewen, P. C., Hu, B., Strutinsky, J., and Sparling, R. (1998) Regulation in the *rpoS* regulon of *Escherichia coli*. *Can. J. Microbiol.* **44**:707-717.
- Lu, L., Hume, M. E., and Pillai, S. D. (2003) Quorum sensing in *Escherichia coli* in response to sub-therapeutic antibiotic exposure (abstract). 103<sup>rd</sup> ASM meeting, Washington, D. C.
- Lu, L., Hume, M. E., and Pillai, S. D. (2004) Autoinducer-2 (AI-2)-like activity associated with foods and its interaction with organic acids used as food additives. *J. Food Prot.* **67**:1457-1462.

Luo, Z. Q., and Farrand, S. K. (2001) The *Agrobacterium tumefaciens* rnd homolog is required for TraR-mediated quorum-dependent activation of Ti plasmid *tra* gene expression. *J. Bacteriol.* **183**:3919-3930.

Luo, Z. Q., Su, S., and Farrand, S. K. (2003) *In situ* activation of the quorum-sensing transcription factor TraR by cognate and noncognate acyl-homoserine lactone ligands: kinetics and consequences. *J. Bacteriol.* **185**:5665-5672.

Lyon, W. R., Madden, J. C., Levin, J. C., Stein, J. L., and Capron, M G. (2001) Mutation of *luxS* affects growth and virulence factor expression in *Streptococcus pyogenes*. *Mol. Microbiol.* **42**:145-157.

Maloy, S. R., Cronan, J. E., Jr. and Freifelder, D. (1994) *Microbial Genetics*. Sudbury, MA: Jones and Bartlett Publishers.

Manefield, M., de Nys, R., Kumar, N., Read, R., Givskov, M., Steinberg, P., and Kjelleberg, S. (1999) Evidence that halogenated furanones from *Delisea pulchra* inhibit acylated homoserine lactone (AHL)-mediated gene expression by displacing the AHL signal from its receptor protein. *Microbiology* **145**:283-291

Manefield, M., Rasmussen, T. B., Henzter, M., Andersen, J. B., Steinberg, P., Kjelleberg, S., and Givskov, M. (2002) Halogenated furanones inhibit quorum sensing through accelerated LuxR turnover. *Microbiology* **148**:1119-1127

Martino, P. D., Fursy, R., Bret, L., Sundararaju, B., and Phillips, R. S. (2003) Indole can act as an extracellular signal to regulate biofilm formation of *Escherichia coli* and other indole-producing bacteria. *Can. J. Microbiol.* **49**:443-449.

Mathesius, U., Mulders, S., Gao, M., Teplitski, M., Caetano-Anolles, G., Rolfe, B. G., and Bauer, W. D. (2003) Extensive and specific response of a eukaryote to bacterial quorum-sensing signals. *Proc. Natl. Acad. Sci. USA* **100**:1444-1449.

McDougald, D., Srinivasan, S., Rice, S. A., and Kjelleberg, S. (2003). Signal-mediated cross-talk regulates stress adaptation in *Vibrio* species. *Microbiology* **149**:1923-1933.

McGowan, S., Sebahia, M., Jones, S., Yu, B., Bainton, N., Chan, P. F., Bycroft, B., Stewart, G. S., Williams, P., and Salmond, G. P. (1995) Carbapenem antibiotic production in *Erwinia carotovora* is regulated by CarR, a homologue of the LuxR transcriptional activator. *Microbiology* **141**:541-550.

McNab, R., and Lamont, R. J. (2003) Microbial dinner-party conversations: the role of LuxS in interspecies communication. *J. Med. Microbiol.* **52**:541-545.

Mellon, M., Benbrook, C., and Benbrook, K. L. (2001) Hogging it: estimates of antimicrobial abuse in livestock. Washington, DC: Union of Concerned Scientists.

- Miller, M. B., and Bassler, B. L. (2001) Quorum sensing in bacteria. *Annu. Rev. Microbiol.* **55**:165-199.
- Miller, M. B., Skorupski, K., Lenz, D. H., Taylor, R. K., and Bassler, B. L. (2002) Parallel quorum sensing systems converge to regulate virulence in *Vibrio cholerae*. *Cell* **110**:303-314.
- Mizan, S., Lee, M. D., Harmon, B. G., Tkalcic, S., and Maurer, J. J. (2002) Acquisition of antibiotic resistance plasmids by enterohemorrhagic *Escherichia coli* O157:H7 within rumen fluid. *J. Food Prot.* **65**:1038-1040.
- Mok, K. C., Wingreen, N. S., and Bassler, B. L. (2003). *Vibrio harveyi* quorum sensing: a coincidence detector for two autoinducers controls gene expression. *EMBO J.* **22**:870-881.
- Molin, S., and Tolker-Nielsen, T. (2003) Gene transfer occurs with enhanced efficiency in biofilms and induces enhanced stabilization of the biofilm structure. *Curr. Opin. Biotechnol.* **14**:255-261.
- Moore, W. E., and Holdeman, L. V. (1974) Human fecal flora: the normal flora of 20 Japanese-Hawaiians. *Appl. Microbiol.* **27**:961-969.
- More, M. I., Finger, L. D., Stryker, J. L., Fuqua, C., Eberhard, A., and Winans S. C. (1996) Enzymatic synthesis of a quorum-sensing autoinducer through use of defined substrates. *Science* **272**:1655-1658.
- Moubareck, C., Bourgeois, N., Courvalin, P., and Doucet-Populaire, F. (2003) Multiple antibiotic resistance gene transfer from animal to human *enterococci* in the digestive tract of gnotobiotic mice. *Antimicrob. Agents Chemother.* **47**:2993-2996.
- Muela, A., Pocino, M., Arana, I., Justo, J. I., Iriberry, J., and Barcina, I. (1994) Effect of growth phase and parental cell survival in river water on plasmid transfer between *Escherichia coli* strains. *Appl. Environ. Microbiol.* **60**:4273-4278.
- Mulvey, M. R., Switala, J., Borys, A., and Loewen, P. C. (1990) Regulation of transcription of *katE* and *katF* in *Escherichia coli*. *J. Bacteriol.* **172**:6713-6720.
- Muscholl-Silberhorn, A., Samberger, E., and Wirth, R. (1997) Why does *Staphylococcus aureus* secrete an *Enterococcus faecalis*-specific pheromone? *FEMS Microbiol. Lett.* **157**:261-266.
- National Academy of Science. (1999) *The Use of Drugs in Food Animal Benefits and Risks*. Washington, DC: National Academy Press.
- Nealson K. H., and Hastings, J. W. (1979) Bacterial bioluminescence: its control and ecological significance. *Microbiol. Rev.* **43**:496-518.

- Nealson, K. H., Platt, T., and Hastings, J. W. (1970) Cellular control of the synthesis and activity of the bacterial luminescent system. *J. Bacteriol.* **104**:313-323.
- Novotny, C. P., and Lavin, K. (1971) Some effects of temperature on the growth of *F. pili*. *J. Bacteriol.* **107**:671-682.
- Nutt, J. D., Li, X., Woodward, C. L., Zabala-Diaz, I. B., and Ricke, S. C. (2003) Growth kinetics response of a *Salmonella* Typhimurium poultry marker strain to fresh produce extracts. *Bioresour. Technol.* **89**:313-316.
- Oger, P., and Farrand, S. K. (2001) Co-evolution of the agrocinopine opines and the agrocinopine-mediated control of TraR, the quorum-sensing activator of the Ti plasmid conjugation system. *Mol. Microbiol.* **41**:1173-1185.
- Oger, P., and Farrand, S. K. (2002) Two opines control conjugal transfer of an *Agrobacterium* plasmid by regulating expression of separate copies of the quorum-sensing activator gene *traR*. *J. Bacteriol.* **184**:1121-1131.
- Ohtani, K., Hayashi, H., and Shimizu, T. (2002) The *luxS* gene is involved in cell-cell signaling for toxin production in *Clostridium perfringens*. *Mol. Microbiol.* **44**:171-179.
- Pansegrau, W., Lanka, E., Barth, P. T., Figurski, D. H., Guiney, D. G., Haas, D., Helinski, D. R., Schwab, H., Stanisich, V. A., and Thomas, C. M. (1994) Complete nucleotide sequence of Birmingham IncP alpha plasmids, compilation and comparative analysis. *J. Mol. Biol.* **239**:623-663.
- Pappas, K. M., and Winans, S. C. (2003) A LuxR-type regulator from *Agrobacterium tumefaciens* elevates Ti plasmid copy number by activating transcription of plasmid replication genes. *Mol. Microbiol.* **48**:1059-1073.
- Pearson, J. P., van Delden, C., and Iglewski, B. (1999) Active efflux and diffusion are involved in transport of *Pseudomonas aeruginosa* cell-to-cell signals. *J. Bacteriol.* **181**:1203-1210.
- Pesci, E. C., Milbank, J. B. J., Pearson, J. P., McKight, S., Kende, A. S., Greenberg, E. P., and Iglewski, B. H. (1999) Quinolone signaling in the cell-to-cell communication system of *Pseudomonas aeruginosa*. *Proc. Natl. Acad. Sci. USA* **96**:11229-11234.
- Phillips, I., Casewell, M., Cox, T., De Groot, B., Friis, C., Hones, R., Nightingale, C., Preston, R., and Waddell, J. (2004) Does the use of antibiotics in food animals pose a risk to human health? A critical review of published data. *J. Antimicrob. Chemother.* **53**:28-52.
- Pinkney, M., Diaz, R., Lanka, E., and Thomas, C. M. (1988) Replication of mini RK2 plasmid in extracts of *Escherichia coli* requires plasmid-encoded protein TrfA and



- host-encoded proteins DnaA, B, G DNA gyrase and DNA polymerase III. *J. Mol. Biol.* **203**:927-938.
- Piper, K. R., Beck von Bodman, S., and Farrand, S. K. (1993) Conjugation factor of *Agrobacterium tumefaciens* regulates Ti plasmid transfer by autoinduction. *Nature* **362**:448-450.
- Pottathil, M., and Lazazzera, B. A. (2003) The extracellular Phr peptide-Rap phosphatase signaling circuit of *Bacillus subtilis*. *Front Biosci.* **8**:d32-45.
- Qin, Y., Luo, Z. Q., Smyth, A. J., Gao, P., Beck von Bodman, S., and Farrand, S. K. (2000) Quorum-sensing signal binding results in dimerization of TraR and its release from membranes into the cytoplasm. *EMBO J.* **19**:5212-5221.
- Rabbani, G. H., Albert, M. J., Hamidur Rahman, A. S., Moyenu Islam, M., Nasirul Islam, K. M., and Alam, K. (1999) Short-chain fatty acids improve clinical, pathologic, and microbiologic features of experimental shigellosis. *J. Infect. Dis.* **179**:390-397.
- Rahmati, S., Yang, S., Davidson, A. L., and Zechiedrich, E. L. (2002) Control of the AcrAB multidrug efflux pump by quorum-sensing regulator SdiA. *Mol. Microbiol.* **43**:677-685.
- Rees, C. E., Dodd, C. E., Gibson, P. T., Booth, I. R., and Stewart, G. S. (1995) The significance of bacteria in stationary phase to food microbiology. *Int. J. Food Microbiol.* **28**:263-275.
- Ren, D., Sims, J. J., and Wood, T. K. (2001) Inhibition of biofilm formation and swarming of *Escherichia coli* by (5Z)-4-bromo-5-(bromomethylene)-3-butyl-2(5H)-furanone. *Environ. Microbiol.* **3**:731-736.
- Rhee, M. S., Lee, S. Y., Dougherty, R. H., and Kang, D. H. (2003) Antimicrobial effects of mustard flour and acetic acid against *Escherichia coli* O157:H7, *Listeria monocytogenes*, and *Salmonella enterica* serovar Typhimurium. *Appl. Environ. Microbiol.* **69**:2959-2963.
- Roberts, A. P., Prattern, J., Wilson, M., and Mullany, P. (1999) Transfer of a conjugative transposon, Tn5397 in a model of oral biofilm. *FEMS Microbiol. Lett.* **177**:63-66.
- Roberts, M. C. (1996) Tetracycline resistance determinants: mechanisms of action, regulation of expression, genetic mobility, and distribution. *FEMS Microbiol. Rev.* **19**:1-24.

- Roe, M. T., Byrd, J. A., Smith, D. P., and Pillai, S. D. (2003a) Class 1 and class 2 integrons in poultry carcasses from broiler house and poultry processing environments. *J. Food Prot.* **66**:1426-1431.
- Roe, M. T., and Pillai, S. D. (2003) Monitoring and identifying antibiotic resistance mechanisms in bacteria. *Poult. Sci.* **82**:622-666.
- Roe, M. T., Vega, E., and Pillai, S. D. (2003b) Antimicrobial resistance markers of class 1 and class 2 integron-bearing *Escherichia coli* from irrigation water and sediments. *Emerging Infect. Dis.* **9**:822-826.
- Salyers, A. A., and Shoemaker, N. B. (1992) Chromosomal gene transfer elements of the *Bacteroides* group. *Eur. J. Clin. Microbiol. Infect. Dis.* **11**:1032-1038.
- Schauder, S., Shokat, K., Surette, M. G., and Bassler, B. L. (2001) The LuxS family of bacterial autoinducers: biosynthesis of a novel quorum-sensing signal molecule. *Mol. Microbiol.* **41**:463-476.
- Schnappinger, D., and Hillen, W. (1996). Tetracyclines: antibiotic action, uptake, and resistance mechanisms. *Arch. Microbiol.* **165**:359-369.
- Sherburne, C. K., Lawley, T. D., Gilmour, M. W., Blattner, F. R., Burland, V., Grotbeck, E., Rose, D. J., and Taylor, D. E. (2000) The complete DNA sequence and analysis of R27, a large IncHI plasmid from *Salmonella typhi* that is temperature sensitive for transfer. *Nucleic Acids Res.* **28**:2177-2186.
- Shoemaker, N. B., Vlamakis, H., Hayes, K., and Salyers, A. A. (2001) Evidence for extensive resistance gene transfer among *Bacteroides* spp. and among *Bacteroides* and other genera in the human colon. *Appl. Environ. Microbiol.* **67**:561-568.
- Showsh, S. A., and Andrew, R. E., Jr. (1992) Tetracycline enhances Tn916-mediated conjugal transfer. *Plasmid* **28**:213-224.
- Sitnikov, D. M., Schineller, J. B., and Baldwin, T. O. (1996). Control of cell division in *Escherichia coli*: regulation of transcription of *ftsQA* involves both *rpoS* and SdiA-mediated autoinduction. *Proc. Natl. Acad. Sci. USA* **93**:336-341.
- Slaughter, J. C. (1999) The naturally occurring furanones: formation and function from pheromone to food. *Biol. Rev. Camb. Philos. Soc.* **74**:259-276.
- Smith, J. N., and Ahmer, B. M. M. (2003) Detection of other microbial species by *Salmonella*: Expression of SdiA regulon. *J. Bacteriol.* **185**:1357-1366.
- Smith, M. G. (1975) *In vivo* transfer of R factors between *Escherichia coli* strains inoculated into the rumen of sheep. *J. Hyg. (Lond)*. **75**:363-370.

- Smith, M. G. (1977a) Transfer of R factors from *Escherichia coli* to salmonellas in the rumen of sheep. *J. Med. Microbiol.* **10**:29-35.
- Smith, M. G. (1977b) *In vivo* transfer of an R factor within the lower gastro-intestinal tract of sheep. *J. Hyg. (Lond).* **79**:259-268.
- Solomon, J. M., Magnuson, R., Srivastava, A., and Grossman, A. D. (1995) Convergent sensing pathways mediate response to two extracellular competence factors in *Bacillus subtilis*. *Genes Dev.* **9**:547-558.
- Speer, B. S., Shoemaker, N. B., and Salyers, A. A. (1992) Bacterial resistance to tetracycline: mechanisms, transfer, and clinical significance. *Clin. Microbiol. Rev.* **5**:387-399.
- Sperandio, V., Li, C. C., and Kaper, J. B. (2002b) Quorum sensing *Escherichia coli* regulator A: a regulator of the LysR family involved in the regulation of the locus of enterocyte effacement pathogenicity island in enterohemorrhagic *E. coli*. *Infect. Immun.* **70**:3085-3093.
- Sperandio, V., Mellie, J. L., Nguyen, W., Shin, S., and Kaper, J. B. (1999) Quorum sensing controls expression of the type III secretion gene transcription and protein secretion in enterohemorrhagic and enteropathogenic *Escherichia coli*. *Proc. Natl. Acad. Sci. USA* **96**:15196-15201.
- Sperandio, V., Torres, A. G., Jarvis, B., Nataro, J. P., and Kaper, J. B. (2003) Bacteria-host communication: The language of hormones. *Proc. Natl. Acad. Sci. USA* **100**:8951-8956.
- Sperandio, V., Torres, A. G., Giron, J. A. and Kaper, J. B. (2001) Quorum sensing is a global regulatory mechanism in enterohemorrhagic *Escherichia coli* O157:H7. *J. Bacteriol.* **183**:5187-5197.
- Sperandio, V., Torres, A. G., and Kaper, J. B. (2002a) Quorum sensing *Escherichia coli* regulators B and C (QseBC): a novel two-component regulatory system involved in the regulation of flagella and motility by quorum sensing in *E. coli*. *Mol. Microbiol.* **43**:809-821.
- Steinmoen, H., Knutsen, F., and Havarstein, L. S. (2002) Induction of natural competence in *Streptococcus pneumoniae* triggers lysis and DNA release from a subfraction of the cell population. *Proc. Natl. Acad. Sci. USA* **99**:7681-7686.
- Stevens, A. M., Sanders, J. M., Shoemaker, N. B., and Salyers, A. A. (1992) Genes involved in production of plasmid-like forms by a *Bacteroides* conjugal chromosomal element share amino acid homology with two-component regulatory systems. *J. Bacteriol.* **174**:2935-2942.

- Stevenson, S. M. L., McAllister, T. A., Selinger, L. B., Yanke, L. J., Olson, M. E., Morck, D. W., and Read, R. R. (2003) Transfer of a rifampicin-resistant *Escherichia coli* strain among feedlot cattle. *J. Appl. Microbiol.* **95**:398-410.
- Stockstad, E. L. R., Jukes, T. H., Pierce, J., Page, A. C., and Franklin, A. L. (1949) The multiple nature of the animal protein factor. *J. Biol. Chem.* **180**:647-654.
- Street, L. M., Harley, M. J., Stern, J. C., Larkin, C., Williams, S. L., Miller, D. L., Dohm, J. A., Rodgers, M. E., and Schildbach, J. F. (2003) Subdomain organization and catalytic residues of the F factor TraI relaxase domain. *Biochim. Biophys. Acta* **1646**:86-99.
- Surette, M. G., and Bassler, B. L. (1998) Quorum sensing in *Escherichia coli*, *Salmonella* Typhimurium. *Proc. Natl. Acad. Sci. USA* **95**:7046-7050.
- Surette, M. G., Miller, M. B., and Bassler, B. L. (1999) Quorum sensing in *Escherichia coli*, *Salmonella* Typhimurium and *Vibrio harveyi*: a new family of genes responsible for autoinducer production. *Proc. Natl. Acad. Sci. USA* **96**:1639-1644.
- Taga, M. E., and Bassler, B. L. (2003) Chemical communication among bacteria. *Proc. Natl. Acad. Sci. USA* **100**:14549-14554.
- Taga, M. E., Miller, S. T., and Bassler, B. L. (2003) Lsr-mediated transport and processing of AI-2 in *Salmonella* Typhimurium. *Mol. Microbiol.* **50**:1411-1427.
- Taga, M. E., Semmelhack, J. L., and Bassler, B. L. (2001) The LuxS-dependent autoinducer AI-2 controls the expression of an ABC transporter that functions in AI-2 uptake in *Salmonella* Typhimurium. *Mol. Microbiol.* **42**:777-793.
- Taylor, D. E., and Chau, A. (1996) Tetracycline resistance mediated by ribosomal protection. *Antimicrob. Agents Chemother.* **40**:1-5.
- Teplitski, M., Chen, H., Rajamani, S., Gao, M., Merighi, M., Sayre, R. T., Robinson, J. B., Rolfe, B. G., and Bauer, W. D. (2004). *Chlamydomonas reinhardtii* secretes compounds that mimic bacterial signals and interfere with quorum sensing regulation in bacteria. *Plant Physiol.* **134**:137-146.
- Teplitski, M., Robinson, J. B., and Bauer, W. D. (2000) Plants secrete substances that mimic bacterial N-acyl homoserine lactone signal activities and affect population density-dependent behaviors in associated bacteria. *Mol. Plant Microbe Interact.* **13**:637-648.
- Teuber, M. (2001) Veterinary use and antibiotic resistance. *Curr. Opin. Microbiol.* **4**:493-499.

- Thomas, D. J. I., Morgan, J. A. W., Whipps, J. M., and Saunders, J. R. (2000) Plasmid transfer between the *Bacillus thuringiensis* subspecies *kurstaki* and *tenebrionis* in laboratory culture and soil and in Lepidopteran and Coleopteran larvae. *Appl. Environ. Microbiol.* **66**:118-124.
- Trieber, C. A., and Taylor, D. E. (2002) Mutations in the 16S rRNA genes of *Helicobacter pylori* mediate resistance to tetracycline. *J. Bacteriol.* **184**:2131-2140.
- Ungemach, F. R. (2000) Figures on quantities of antibacterials used for different purposes in the EU-countries and interpretation. *Acta Vet. Scand.* **93**:89-98.
- U. S. Food and Drug Administration. (2001) *Feed Additive Compendium*. Minnetonka, MN: Miller Publishing Co., pp 328-337.
- U. S. Food and Drug Administration. (2004) *Feed Additive Compendium*. Minnetonka, MN: Miller Publishing Co.
- Van den Bogaard, A. E. (1997) Antimicrobial resistance – relation to human and animal exposure to antibiotics. *J. Antimicrob. Chemoter.* **40**:453-454.
- Van Immerseel, F., De Buck, J., Pasmans, F., Velge, P., Bottreau, E., Fievez, V., Haesebrouck, F., and Ducatelle, R. (2003) Invasion of *Salmonella enteritidis* in avian intestinal epithelial cells *in vitro* is influenced by short-chain fatty acids. *Int. J. Food Microbiol.* **85**:237-248.
- Walmsley, R. H. (1976) Temperature dependence of mating-pair formation in *Escherichia coli*. *J. Bacteriol.* **126**:222-224.
- Wang, D., Ding, X., and Rather, P. N. (2001) Indole can act as an extracellular signal in *Escherichia coli*. *J. Bacteriol.* **183**:4210-4216.
- Wang, Y., Wang, G. R., Shelby, A., Shoemaker, N. B., and Salyers, A. A. (2003) A newly discovered *Bacteroides* conjugative transposon, CTnGERM1, contains genes also found in Gram-positive bacteria. *Appl. Environ. Microbiol.* **69**:4595-4603.
- Wei, Y., Lee, J. M., Smulski, D. R., and LaRossa, R. A. (2001) Global impact of *sdiA* amplification revealed by comprehensive gene expression profiling of *Escherichia coli*. *J. Bacteriol.* **183**:2265-2272.
- Whittle, G., Shoemaker, N. B., and Salyers, A. A. (2002a) The role of *Bacteroides* conjugative transposons in the dissemination of antibiotic resistance genes. *Cell Mol. Life Sci.* **59**:2044-2054.
- Whittle, G., Shoemaker, N. B., and Salyers, A. A. (2002b) Characterization of genes involved in modulation of conjugal transfer of the *Bacteroides* conjugative transposon CTnDOT. *J. Bacteriol.* **184**:3839-3847.

Williams, P., Bainton, N. J., Swift, S., Chhabra, S. R., Winson, M. K., Stewart, G. S., Salmond, G. P., and Bycroft, B. W. (1992) Small molecule-mediated density-dependent control of gene expression in prokaryotes: bioluminescence and the biosynthesis of carbapenem antibiotics. *FEMS Microbiol. Lett.* **79**:161-167.

Winzer, K., Hardie, K. R., Burgess, N., Doherty, N., Kirke, D., Holden, M. T. G., Linforth, R., Cornell, K. A., Taylor, A. J., Hill, P. J., and Williams, P. (2002b) LuxS: its role in central metabolism and the *in vitro* synthesis of 4-hydroxy-5-methyl-3(2H)-furanone. *Microbiology* **148**:909-922.

Winzer, K., Hardie, K. R., and Williams, P. (2002a) Bacterial cell-to-cell communication: sorry, can't talk now - gone to lunch! *Curr. Opin. Microbiol.* **5**:216-222.

Withers, H. L., and Nordstrom, K. (1998) Quorum-sensing acts at initiation of chromosomal replication in *Escherichia coli*. *Proc. Natl. Acad. Sci. USA* **95**:15694-15699.

Withers, H., Swift, S., and Williams, P. (2001) Quorum sensing as an integral component of gene regulatory networks in Gram-negative bacteria. *Curr. Opin. Microbiol.* **4**:186-193

Xavier, K. B., and Bassler, B. L. (2003) LuxS quorum sensing: more than just a numbers game. *Curr. Opin. Microbiol.* **6**:1-7.

Zambrano, M. M., and Kolter, R. (1996) GASping for life in stationary phase. *Cell* **86**:181-184

Zatyka, M., Jagura-Burdzy, G., and Thomas, C. M. (1994) Regulation of transfer genes of promiscuous IncP alpha plasmid RK2: repression of TraI region transcription both by relaxosome proteins and by the Tra2 regulator TrbA. *Microbiology* **140**:2981-2990.

Zhang, L, Lin, J., and Ji, G. (2004) Membrane anchoring of the AgrD N-terminal amphipathic region is required for its processing to produce a Quorum sensing pheromone in *Staphylococcus aureus*. *J. Biol. Chem.* **279**:19448-19456.

Ziegelin, G., Pansegrau, W., Strack, B., Balzer, D., Kroger, M., Kruft, V., and Lanka, E. (1991) Nucleotide sequence and organization of genes flanking the transfer origin of promiscuous plasmid RP4. *DNA Sequence J. DNA Sequencing Mapp.* **1**:303-327.

## VITA

### Lingeng Lu

RM 301, 415/46, No. 2 Hongbao Residential Square  
Xidu, Fengxian, Shanghai, 201401, China  
Email: L5201\_@hotmail.com

**EDUCATION:** Texas A & M University, College Station, TX  
Ph.D., Food Science and Technology. August 2004

Shanghai Medical University, Shanghai, China  
M.M., Epidemiology. July 1998

Shanghai Medical University, Shanghai, China  
B.M., Medicine. July 1991

### PROFESSIONAL AND ACADEMIC APPOINTMENTS:

2000-2004. Research Assistant, Food Safety and Environmental Microbiology, Institute of Food Science and Engineering and Poultry Science Department, TAMU. Advisor: Dr. Suresh D. Pillai.  
1991-2000. Assistant Professor, Shanghai University of TCM, Shanghai, China.

### PROFESSIONAL ACTIVITIES:

Board Member of Shanghai Society for Preventive Medicine (Professional committee)  
Member of Chinese Society for Molecular Biology and Biochemistry  
Member of American Society for Microbiology  
Member of Sigma Xi

### SELECTED PUBLICATIONS AND CONFERENCE ABSTRACTS:

**Lu, L.**, M. E. Hume and S. D. Pillai. 2004. Genetic Diversity of *Escherichia coli* isolates in Irrigation Water and Associated Sediments: Implications for Source Tracking. Water Res. (In Press).

**Lu, L.**, M. E. Hume and S. D. Pillai. AI-2 molecules can influence tetracycline resistance development in *Escherichia coli* by promoting transfer of *tet(A)* gene between resistant and sensitive strains. 104<sup>th</sup> meeting of ASM in New Orleans. May 2004.

Endley, S., **L. Lu**, E. Vega, M. E. Hume and S. D. Pillai. 2003. Male-specific coliphages as Fecal Contamination Indicators for Screening Vegetable Produce. J. Food Prot. 66:88-93.

**Lu, L.**, S. Yu, Y. Zhang and G. Wei. 2000. Prevalence of *Escherichia coli* O157 in Shanghai. Chin. J. Epidemiol. 21:456.

**Lu, L.**, J. Ke and Z. Wang. 2000. Correspond analysis for the treatment dependent on differential syndrome. J. Math. Statistics. 13:272-273.