

**MITOCHONDRIAL AND NUCLEAR ASSESSMENT OF FERRUGINOUS
PYGMY-OWL (*GLAUCIDIUM BRASILIANUM*) PHYLOGEOGRAPHY**

A Dissertation

by

GLENN ARTHUR PROUDFOOT

Submitted to the Office of Graduate Studies of
Texas A&M University
in partial fulfillment of the requirements for the degree of

DOCTOR OF PHILOSOPHY

May 2005

Major Subject: Wildlife and Fisheries Sciences

**MITOCHONDRIAL AND NUCLEAR ASSESSMENT OF FERRUGINOUS
PYGMY-OWL (*GLAUCIDIUM BRASILIANUM*) PHYLOGEOGRAPHY**

A Dissertation

by

GLENN ARTHUR PROUDFOOT

Submitted to the Office of Graduate Studies of
Texas A&M University
in partial fulfillment of the requirements for the degree of

DOCTOR OF PHILOSOPHY

Approved as to style and content by:

Rodney L. Honeycutt
(Co-Chair of Committee)

Nova J. Silvy
(Member)

R. Douglas Slack
(Co-Chair of Committee)

Felipe Chavez-Ramirez
(Member)

Robert D. Brown
(Head of Department)

May 2005

Major Subject: Wildlife and Fisheries Sciences

ABSTRACT

Mitochondrial and Nuclear Assessment of Ferruginous Pygmy-Owl (*Glaucidium
brasilianum*) Phylogeography.

Glenn Arthur Proudfoot, B.S., University of Wisconsin-Stevens Point;

M.S., Texas A&M University-Kingsville

Co-Chairs of Advisory Committee: Dr. Rodney L. Honeycutt
Dr. R. Douglas Slack

Sequences of the cytochrome *b* gene and genotypes from 11 polymorphic microsatellite loci were used to assess phylogeographic variation in ferruginous pygmy-owls (*Glaucidium brasilianum*) from Arizona, Mexico, and Texas. Analysis of mtDNA indicated that pygmy-owl populations in Arizona and Texas are unique, with no shared haplotypes. Populations from Sonora and Sinaloa, Mexico, were distinct from remaining populations in Mexico and grouped closest to haplotypes in Arizona. Nested clade analysis of mtDNA sequence data indicated past fragmentation separated pygmy-owls into two major groups: 1) Arizona, Sonora and Sinaloa, Mexico, and 2) southwestern (Nayarit and Michoacan), south-central (Oaxaca and Chiapas), and eastern Mexico, along the eastern slope of the Sierra Madre Oriental from Texas to Central America. In addition, analysis of mtDNA variation in several species of *Glaucidium* support the recommendation that populations of *G. brasilianum* from Mexico, Texas, and Arizona represent a phylogenetically distinct group from populations occurring in South America. The level of separation between the North and South American

populations justifies granting species status (*G. ridgwayi*) to the North American population. Analysis of distance matrices derived from genotypes of 11 polymorphic microsatellite loci supports restricted gene flow between pygmy-owl populations in Arizona-Sonora and Sinaloa, and Texas-Tamaulipas and the remainder of states in Mexico. The Arizona-Sonora population showed signs of a recent genetic bottleneck, an observation supported by low population estimates for Arizona (13-117 individuals). Heterozygosity in Arizona, however, was equal to levels recorded throughout Mexico and Texas. Congruent patterns revealed by both mtDNA and nuclear DNA (microsatellites) indicate Arizona and Texas populations are distinct subspecies that require the design and implementation of separate management plans for recovery and conservation efforts.

DEDICATION

To Jennifer E. Walter, my best friend and loving wife.

ACKNOWLEDGMENTS

A project of this nature would not be possible without the assistance of numerous individuals distributed across national and international boundaries. It would be difficult to extend full credit to all those involved; however, I would like to extend sincere thanks to several key players.

To my co-chairs, Drs. Rodney L. Honeycutt and R. Douglas Slack, my deepest appreciation for their guidance and insight. To my committee members, Drs. Felipe Chavez-Ramirez and Nova J. Silvy, my sincere gratitude for their comments and direction.

Those who assisted with either research or technical support include Dennis J. Abbate, Scott T. Blackman, Aaron D. Flesch, Michael F. Ingraldi, Saraha J. Lantz, Shawn F. Lowery, Jody L. Mays, Eduardo L. Moreno, Elizabeth Ochoa, W. Scott Richardson, and Renee L. Wilcox in the United States; E. Lopez Saavedra and the staff at Instituto Del Medio Ambiente y el Desarrollo assisted research efforts in Sonora, Mexico; X. Vega Picos, F. Garcia Cecena, M. A. Guevara Medina, and J. C. Leyva Martínez and at Instituto Tecnológico y de Estudios provided assistance in Sinaloa and Nayarit, Mexico. Xico not only provided assistance in the field and with permitting in Mexico, but he and his family graciously opened their home to a wandering band of strangers from the U.S. For this I am truly grateful. Laurence J. Frabotta and Jennifer E. Walter used their computer expertise to guide me through the Mac quagmire. April D. Harlin-Cognato graciously introduced me to Arlequin and nested clade analysis.

I would be remiss if I did not thank all who reside on the Norias Division of the King Ranch, whose friendship will not be forgotten. They include Johnny and Cindy Gonzales, Roberto and Norma Garcia, Ramiro and Jannie Lerma, Joe Gonzales, and Ricardo Lopez. I extend my deepest appreciation to Gus and Janis Puente, who unselfishly gave their friendship and left their door unlocked throughout my years at Norias.

Butch Thompson and Tom Langschied at the King Ranch deserve special recognition for opening gates, literally and professionally, and allowing this project to pass through without delay. Phil & Karen Hunke opened the gates of their ranch with true southern hospitality, offering to assist and support each and every research endeavor. Thank you!

To my fellow gel jockies, Joel Anderson, Kiara Banks, Scott Chirhart, April Harlin-Cognato, Katie Connell, Amanda Crouse, Laurence Frabotta, Colleen Ingram, Diane Rowe, Jamie Schroeder, and Mindy Walker, "I'm so glad we had this time together." To "Patton," thanks for separating the forest from the trees; primer design can be done. To Robert Trujillo, "Let's have lunch." I thank Diann, Janice, Jennifer, Linda, Melissa, Sherry, Shirley, and Vicki of our departmental staff for all their help. Roel, that summer support came at the right time. Thanks!

Loan of ferruginous pygmy-owl tissues was the courtesy of the Chicago Field Museum of Natural History and the University of California Museum of Vertebrate Zoology; Michael Wink of Heidelberg, Germany provided total genomic DNA from ferruginous pygmy-owls in Argentina. Funding was provided by Pima County Arizona,

Arizona Game and Fish Department, United States Fish and Wildlife Service, Tucson
Audubon Society, Conservation Action Grant of the Texas Parks and Wildlife
Department, Defenders of Wildlife, Phil H. & Karen S. Hunke at El Tecolote Ranch, R.
R. Johnson, and Jennifer E. Walter. Logistical support was provided by the King Ranch
Inc., Kenedy Ranch Inc., Ray and Monica Berdett at El Canelo Ranch, and the
University of Arizona. A Sloan Fellowship Grant provided academic support.

TABLE OF CONTENTS

| | Page |
|--|------|
| ABSTRACT | iii |
| DEDICATION | v |
| ACKNOWLEDGMENTS | vi |
| TABLE OF CONTENTS | ix |
| LIST OF FIGURES | xi |
| LIST OF TABLES | xii |
| CHAPTER | |
| I INTRODUCTION | 1 |
| Natural History | 1 |
| Objective: Assess Genetic Variation in Pygmy-Owls from Arizona, Texas, and Mexico | 3 |
| II MITOCHONDRIAL DNA VARIATION AND PHYLOGEOGRAPHY OF THE FERRUGINOUS PYGMY-OWL (GLAUCIDIUM BRASILIANUM) | 5 |
| Introduction | 5 |
| Methods | 8 |
| Results | 16 |
| Discussion | 24 |
| III DEVELOPMENT AND CHARACTERIZATION OF MICROSATELLITE DNA PRIMERS FOR FERRUGINOUS PYGMY-OWLS (GLAUCIDIUM BRASILIANUM) | 28 |
| Introduction | 28 |
| Methods | 29 |
| Results & Discussion | 30 |

| CHAPTER | Page |
|---|------|
| IV VARIATION IN DNA MICROSATELLITES OF THE FERRUGINOUS PYGMY-OWL (<i>GLAUCIDIUM BRASILIANUM</i>) | 34 |
| Introduction | 34 |
| Methods | 36 |
| Results | 44 |
| Discussion | 52 |
| V SUMMARY | 58 |
| REFERENCES | 59 |
| VITA | 73 |

LIST OF FIGURES

| Figure | | Page |
|--------|---|------|
| 1 | Collection locations for North American <i>G. brasilianum</i> | 9 |
| 2 | Genetic relationship of members of <i>Glaucidium</i> from Old and New World populations (cytochrome <i>b</i> gene) | 28 |
| 3 | Haplotype network and associated nested design for nested clade analysis of North American pygmy-owls | 22 |
| 4 | Location of collection sites for North American <i>G. brasilianum</i> | 38 |
| 5 | Relationship of pygmy-owl populations based on genetic distances of alleles in 11 polymorphic loci | 51 |

LIST OF TABLES

| TABLE | Page |
|-------|--|
| 1 | Approximate geographic location of sample areas for <i>G. brasilianum</i> from North America 10 |
| 2 | Pairwise distances (km) used in nested clade analysis for <i>Glaucidium brasilianum</i> from North America 17 |
| 3 | Below the diagonal are proportions of pairwise nucleotide substitutions between species of <i>Glaucidium</i> from Old World, North and Central and South American populations 20 |
| 4 | Summation of nested clade analysis 23 |
| 5 | Characterization of 10 polymorphic microsatellite loci developed from ferruginous pygmy-owl DNA 31 |
| 6 | Cross-species amplification using microsatellite loci designed in ferruginous pygmy-owl 33 |
| 7 | Characterization of 11 polymorphic microsatellite loci used to assay genetic variation in pygmy-owls 40 |
| 8 | Heterozygosity observed in pygmy-owls, by population (n) and locus 46 |
| 9 | Allelic patterns across pygmy-owl populations (n) 47 |
| 10 | Pairwise R_{st} (below diagonal) and F_{st} (above diagonal) values for pygmy-owl populations (n), calculated from 11 polymorphic microsatellite loci 47 |
| 11 | Assignment of pygmy-owls based upon Rannala and Mountain's (1997) assignment test 49 |

CHAPTER I

INTRODUCTION

Natural History

The ferruginous pygmy-owl (*Glaucidium brasilianum*; hereafter referred to as pygmy-owl) is a permanent resident from the southwestern United States (U.S.) to southern South America. It occupies a wide variety of ecosystems, from semi-arid desertscrub to lush tropical rainforest. Pairs typically nest in cavities either excavated by woodpeckers or those formed by limb decay, and less often in forks or depressions in trees. In the U.S. this species inhabits live oak-honey mesquite (*Quercus virginiana-Prosopis glandulosa*) woodlands, mesquite brush, and riparian areas of extreme southeastern Texas and riparian woodlands and Sonoran desert-scrub of south-central Arizona. In forested areas, nest sites are usually at the edge of clearings (Proudfoot and Johnson 2000).

Pygmy-owls are presumed monogamous, forming pairs during the fall in the first year after hatching, and nesting the following spring. Incubation and nestling development each last about 28 days. The female incubates 2-7 eggs, and both adults provide food for nestlings. Adults attend to fledglings until dispersal, 7-8 weeks after fledging (Proudfoot & Johnson 2000).

An opportunistic predator, the pygmy-owl's diet is as diverse as its distribution,

including insects, reptiles, amphibians, birds, and small mammals. Foraging rates peak during twilight hours, around sunrise and sunset. Because of its small size, long tail, and atypical diurnal and crepuscular behavior, the pygmy-owl may easily be mistaken for a passerine. When agitated, it perches with its tail cocked upward or jerks its tail up and down and from side to side (Proudfoot & Johnson 2000). On average, females are larger than males (Ridgway 1914), with characteristic pygmy-owl shape (relatively long tail, lack of ear-tufts), dark "false eye" spots on back of head, and polymorphic plumage color and tail pattern.

Status

From 1840-1991 the pygmy-owl was the most collected species of owl in Mexico (Enriquez-Rocha et al. 1993), and it may be the most common small owl in lowland areas of the American tropics (Oberholser 1974). At the northern extreme of its range in Arizona, however, it is considered scarce and listed as endangered (U.S. Fish & Wildlife Service 1997), even though formerly common in cottonwood-mesquite (*Populus-Prosois*) woodlands and forests, nesting in Gila Woodpecker (*Melanerpes uropygialis*) and Gilded Flicker (*Colaptes chrysoides*) cavities. In 1999, only 41 adult pygmy-owls were known to exist in Arizona. In 2000 and 2001, population sizes in Arizona were 34 and 36 adults, respectively (U.S. Fish & Wildlife Service 2003).

The pygmy-owl reveals a similar history in Texas to that of the species in Arizona. Although in the early 1900s the pygmy-owl was a common breeder in Texas (Griscom & Crosby 1926), by the mid-1900s the pygmy-owl populations experienced notable decline. The species was considered "rare" after 90% of mesquite-ebony

(*Pithecellobium flexicaule*) woodlands of Rio Grande delta were cleared for urban and agricultural development, with most of the clearing occurring between 1920 and 1945 (Oberholser 1974). In late 1960s a small population was found in Kenedy Co., TX (Falls 1973).

Objective: Assess Genetic Variation in Pygmy-Owls from Arizona, Texas, and Mexico

In 1994 the U.S. Fish & Wildlife Service proposed listing ferruginous pygmy-owls in Arizona and Texas as endangered and threatened, respectively. In the final ruling, the Arizona population was listed as endangered, and the Texas population was not listed. Deviation from the proposed listing was authorized as a consequence of a clause in the endangered species act that allowed for separate listings of recognized subspecies or populations that are considered distinct, separated geographically, genetically, or by international boundaries (U.S. Fish & Wildlife Service 1997). Pygmy-owl populations in Arizona and Texas are geographically separated by > 1,000 km, they are non-migratory, and have limited dispersal distance (Proudfoot & Johnson 2000). No information suggests current or past direct connectivity between the Arizona and Texas populations. Peters (1940) recognized populations in southwestern Arizona south to Nayarit in western Mexico as *G. b. cactorum*, and other populations in Mexico and Texas were relegated to *G. b. ridgwayi*. However, currently the two populations in the U.S. are considered the same subspecies *G. b. cactorum* (Friedmann et al. 1950, AOU 1957, U.S. Fish & Wildlife Service 1997). Friedmann et al. (1950) recognized only *G. b. cactorum* occurring in the U.S. and suggested that the distribution of *G. b. ridgwayi*

geographically subdivided populations of *G. b. cactorum*. From a phylogenetic standpoint, the taxonomic distribution proposed by Freidmann et al. (1950) would require either recent separation of the Arizona and Texas populations through geographic fragmentation or existence of long distance dispersal. Although pygmy-owls from Arizona and Texas showed morphological similarities, Proudfoot & Johnson (2000, p4) considered the taxonomic distribution proposed by Friedmann et al. (1950) to be “a highly unlikely distribution based on geographical grounds.” The statement made by Proudfoot & Johnson (2000) was based on a consideration of both ecology and phylogenetics. For example, the similarity in the morphology of pygmy-owls from Arizona and Texas can be explained by latitudinal affinity and Bergman’s rule, whereby animals tend to be larger in colder regions. As pygmy-owls expanded their range along the Pacific and Gulf coasts, populations at corresponding latitudes may have co-evolved morphologically. Because pygmy-owls are nonmigratory with limited dispersal distance, it also is logical to assume that patterns of divergence are the result of stepping-stone evolution (Kimura 1953). To address the taxonomic confusion of *G. brasilianum* and ascertain the validity of distinct population status, the objectives of this study are to: 1) determine if pygmy-owl population in Arizona and Texas are genetically distinct; 2) to assess patterns of genetic structure and gene flow between populations; 3) and to make management recommendations to agencies in charge of conservation and recovery efforts. A prerequisite to carrying out these objectives was an assessment of the relationship between pygmy-owls from North and South America.

CHAPTER II

**MITOCHONDRIAL DNA VARIATION AND PHYLOGEOGRAPHY OF
THE FERRUGINOUS PYGMY-OWL (*GLAUCIDIUM BRASILIANUM*)**

Introduction

The ferruginous pygmy-owl (*Glaucidium brasilianum*, hereafter referred to as pygmy-owl) has an historical range that includes areas in southern Arizona, southern Texas, and regions extending from northern Mexico to Chile (Ridgway 1914, Proudfoot & Johnson 2000). Traditional pygmy-owl habitat in the United States includes mesquite (*Prosopis* spp.) woodlands and cottonwood (*Populus* spp.) forests in the Salt, Verde, and Gila river areas of Arizona, and mesquite brush, ebony (*Pithecellobium* spp.), and riparian areas in the Lower Rio Grande Valley of Texas (Gilman 1909, Millsap 1987). Unfortunately, by the early 1970's land-use practices resulted in a depletion of over 90% of pygmy-owl habitat in Texas (Oberholser 1974), thus severely reducing population sizes. Similar land-use practices and destruction of riparian areas are credited with extirpating the pygmy-owl as a regular nesting species in Arizona (Johnson et al. 1979). In 1999, only 41 adult pygmy-owls were known to exist in Arizona. In 2000 and 2001, population sizes in Arizona were 34 and 36 adults, respectively (U.S. Fish & Wildlife Service 2003).

From a taxonomic standpoint, populations in southwestern Arizona through Colima and Jalisco in western Mexico as well as populations in southern Texas south to Nuevo Leon and Tamaulipas in eastern Mexico are recognized as a distinct subspecies,

G. b. cactorum (Friedmann et al. 1950, AOU 1957, U.S. Fish & Wildlife Service 1994, 1997). As a consequence of population declines, the taxonomic uniqueness of pygmy-owls in this region and the separation of populations by political boundaries in the United States and Mexico, the U.S. Fish & Wildlife Service proposed listing pygmy-owl populations in Arizona as endangered and those in Texas as threatened (U.S. Fish & Wildlife Service 1994). The final ruling on this proposal resulted in listing only the Arizona population as endangered (U.S. Fish & Wildlife Service 1997).

Although *G. b. cactorum* is recognized by the American Ornithological Union (1957) and the U.S. Fish & Wildlife Service (1994, 1997), the current taxonomy of the pygmy-owl is complicated, thus making it difficult to objectively characterize overall patterns of geographic variation, a requisite for establishing a comprehensive management plan. For instance, of the approximately 15 recognized subspecies of pygmy-owl (Proudfoot & Johnson 2000), as many as four subspecies have been recognized in North America (Peters 1940, Friedmann et al. 1950, AOU 1957, Phillips 1966, Holt et al. 1999). Peters (1940) recognized populations in southwestern Arizona south to Nayarit in western Mexico as *G. b. cactorum*. Other populations were relegated to *G. b. ridgwayi*, a subspecies occurring in the Lower Rio Grande Valley in Texas southward along the Atlantic slope in eastern Mexico to Panama, as well as from Jalisco, Mexico, south to tropical Central America and the Canal Zone. If patterns of geographic variation are found to support this taxonomic decision, then two separate units of conservation are warranted. Friedmann et al. (1950) suggested that populations of *G. b. ridgwayi* geographically subdivide populations of *G. b. cactorum*, a division Proudfoot

& Johnson (2000) considered highly unlikely. Nevertheless, Friedmann et al.'s (1950) recognition of only *G. b. cactorum* occurring in the United States implies one conservation unit. Because only slight differences in size (e.g., wing and tail length), pattern (e.g., streaking and coloration, which grade with local humidity), and vocalization (which are broadly similar over entire range) are used to characterize subspecies, evaluation of these competing taxonomic treatments is complicated (König et al. 1999, Proudfoot & Johnson 2000).

Numerous studies of threatened and endangered populations and species have employed genetic approaches for both the assessment of population vulnerability and the identification of units of conservation (Avice 1994), and several of these approaches have been applied to avian species (Barrowclough 1992, Haig & Avice 1995, Zink et al. 2000, Eggert et al. 2004, Martinez-Cruz et al. 2004). From a phylogeographic standpoint, historical barriers to dispersal and more recent impediments to gene flow contribute to the fragmentation of a species' range, and these geographically defined units do not always coincide with current subspecific boundaries (Avice 2000). Therefore, the identification of genetically and phylogenetically defined units provides an objective means of identifying both evolutionary significant units (e.g., phylogenetic species) and management units (Moritz 1994).

As indicated by several authors (Heidrich & Wink 1994, Heidrich et al. 1995, König & Wink 1995, Johns & Avice 1998), mtDNA provides an effective marker for examining phylogeographic structure within species and has proven useful at several geographic scales (Zink 1997, 2002; Zink et al. 1998, 2001). In this paper,

mitochondrial DNA (mtDNA) markers are used to investigate patterns of geographic variation and levels of genetic divergence in pygmy-owl populations from Arizona, Texas, and regions in Mexico. Sequences from North American pygmy-owls are further compared to sister taxa from Eurasia, Africa, and South America. Given the controversies surrounding the uniqueness of pygmy-owl populations, especially those in Arizona, this study is essential to the design of a viable management plan for pygmy-owls (U.S. Fish & Wildlife Service 2003).

Methods

Sampling

Whole blood and tissue biopsies from feather pulp were taken from individual pygmy-owls collected in Arizona and Texas, U.S., and in Nayarit, Sinaloa, and Sonora, Mexico (Figure 1, Table 1). One-hundred-three specimens were examined from Arizona ($n = 14$), Mexico ($n = 71$), and Texas ($n = 18$). In Arizona and Texas, samples were obtained as part of banding studies conducted from 1994-2004. In an effort to minimize bias from the inclusion of siblings, when samples were taken from nestlings, only one individual per nest site was used in the phylogeographic comparisons. In Mexico, adult pygmy-owls were sampled from the following locations: 1) samples from Nayarit ($n = 4$) in proximity (ca. 10 km to 15 km) to Laguna Laguna at Santa Maria del Oro; 2) Sinaloa ($n = 5$) along the Río Tamazula near (ca. 15 km to 25 km) Culiacán; and 3) Sonora ($n = 6$), in the proximity of Magnalena de Kino, Hermosillo, and the southeastern reaches of the Río Yaqui. All sample sites were within 35 km of latitudes and longitudes provided in Table 1, as determined by a Trimble® GPS Pathfinder *Basic* + global positioning

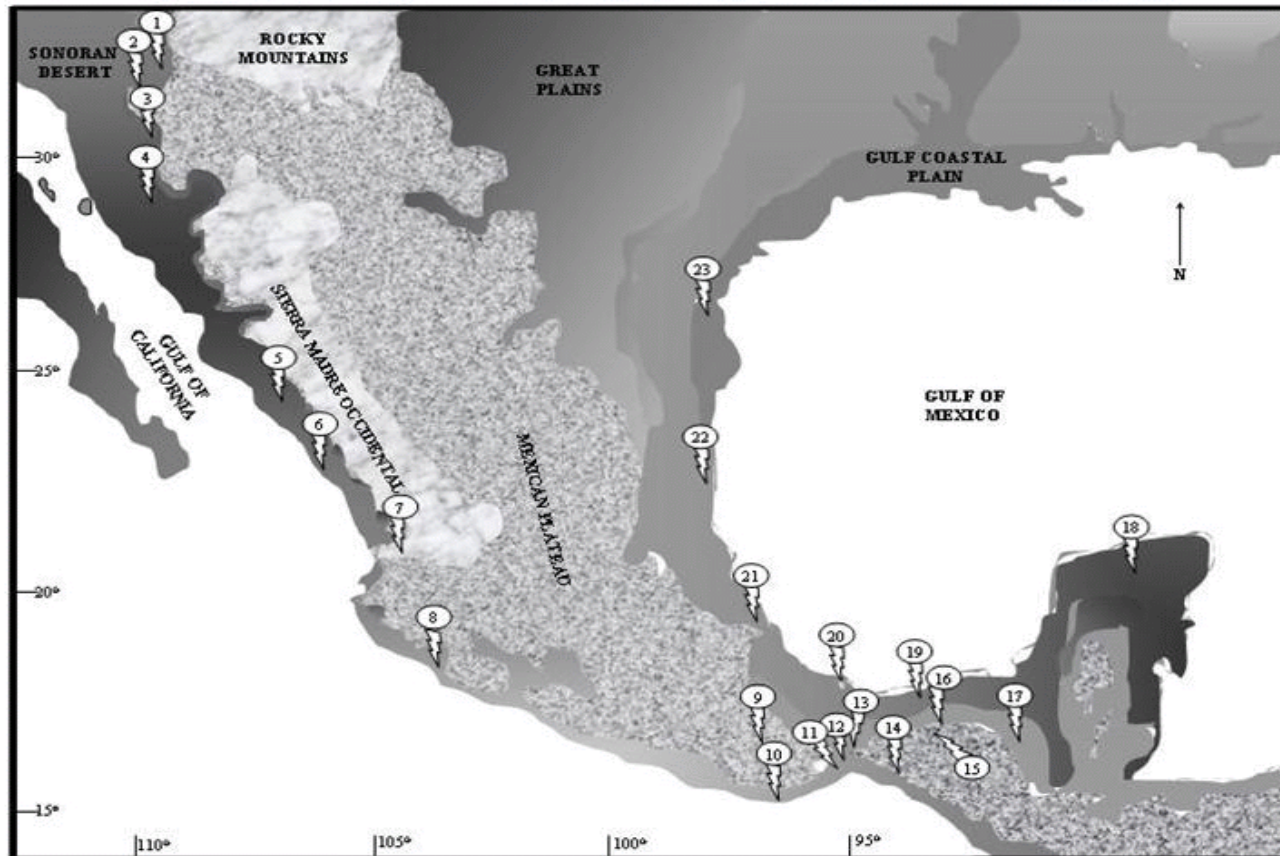

Figure 1. Collection locations for North American *G. brasilianum*. The tips of the lightning-bolts correspond to within one minute of both latitude and longitude of sample areas provided in Table 1.

Table 1. Approximate geographic location of sample areas for *G. brasilianum* from North America.

| # | Location | Latitude & Longitude | Haplotypes (no. of individuals) |
|----|------------------|------------------------|--|
| 1 | NW Tucson, AZ | 032° 36' N, 111° 11' W | C (10) |
| 2 | Altar Valley, AZ | 031° 29' N, 111° 33' W | C (1), D (2), L (1) |
| 3 | Sonora 1 | 030° 40' N, 111° 00' W | C (1), L (1) M (1) |
| 4 | Sonora 2 | 029° 12' N, 110° 47' W | K (3) |
| 5 | Sinaloa 1 | 024° 47' N, 107° 24' W | D (3), K (1), N (1) |
| 6 | Sinaloa 2 | 023° 12' N, 106° 25' W | D (1) |
| 7 | Nayarit | 021° 20' N, 104° 35' W | A (3), J (2) |
| 8 | Michoacan | 018° 45' N, 103° 40' W | A (1), F (1), J (1), O (1), W (1), X (1), CC (1), DD (1) |
| 9 | Oaxaca 1 | 017° 03' N, 096° 43' W | G (1) |
| 10 | Oaxaca 2 | 015° 44' N, 096° 27' W | V (1) |
| 11 | Oaxaca 3 | 016° 22' N, 095° 39' W | A (2), T (1), Z (1), |
| 12 | Oaxaca 4 | 016° 34' N, 095° 06' W | A (1), Q (1), R (1), |
| 13 | Oaxaca 5 | 016° 53' N, 095° 01' W | A (1), G (1) |
| 14 | Chiapas 1 | 016° 14' N, 093° 53' W | A (1) |
| 15 | Chiapas 2 | 016° 44' N, 093° 06' W | H (1), BB (1) |
| 16 | Chiapas 3* | 017° 33' N, 092° 56' W | A (4), F (1), U (1) |
| 17 | Chiapas 4 | 016° 55' N, 091° 21' W | A (1), I (1) |
| 18 | Yucatan | 020° 40' N, 088° 35' W | H (1) |
| 19 | Tabasco* | 018° 00' N, 093° 22' W | A (2), E (3), S (1) |
| 20 | Veracruz 1* | 018° 26' N, 095° 04' W | A (4), G (1), I (2), Y (1), AA (1) |
| 21 | Veracruz 2 | 020° 00' N, 096° 57' W | A (1), I (1), P (1) |
| 22 | Tamaulipas | 022° 55' N, 097° 56' W | B (3), G (1) |
| 23 | Texas | 026° 83' N, 097° 70' W | B (18) |

Information from field notes and Encarta[®] 2000 (Microsoft[®], Redmond, WA) were used to obtain latitude and longitude for museum samples. # corresponds to localities in Figure 1 and haplotype letters are the same as in Figures 2 and 3.

system. It was assumed that spacing between and within sample areas reduced the probability of examining related individuals derived from the same female lineage. Museums provided alcohol preserved and dry (toe pad) tissue samples from 79 pygmy-owls collected at additional localities in Mexico. Mitochondrial sequences were successfully obtained from 56 museum samples obtained from Chiapas ($n = 7$), Michoacan ($n = 8$), Nayarit ($n = 1$), Oaxaca ($n = 13$), Sinaloa ($n = 1$), Tabasco ($n = 10$), Tamaulipas ($n = 4$), Veracruz ($n = 11$), and Yucatan ($n = 1$), Mexico. Accession numbers for samples provided by the University of California Museum of Vertebrate Zoology at Berkeley include MVZFC 22474—22575 and MVZFC 20006.

König et al. (1999) suggested that pygmy-owls from North America and South America represent two distinct species (*G. ridgwayi* & *G. brasilianum*, respectively). If this separation is valid, the South American population of *G. brasilianum* would provide the consummate outgroup for comparative analysis of North American pygmy-owls. Because the separation is unclear, sequences from two Old World (*G. passerinum*, $n = 3$, *G. tephronotum*, $n = 1$), and eight New World species of *Glaucidium* were used as outgroups. New World species included the mountain pygmy-owl (*G. gnoma*, $n = 1$), Andean pygmy-owl (*G. jardinii*, $n = 1$), yungas pygmy-owl (*G. bolivianum*, $n = 1$), Amazonian pygmy-owl (*G. hardyi*, $n = 2$), Austral pygmy-owl (*G. nanum*, $n = 1$), Peruvian pygmy-owl (*G. peruanum*, $n = 1$), ferruginous pygmy-owl (*G. brasilianum*, $n = 7$) from South America, and the Chaco pygmy-owl (*G. tucumanum*, $n = 4$). Accession numbers for sequences downloaded from GenBank include: AJ003975—AJ003977, AJ003979, AJ003981, AJ003982, AJ003984, AJ003987—AJ003991, AJ003994,

AJ003996—AJ003999, and AJ004002—AJ004006 (Wink & Heidrich 1999).

Data Collection

Total DNA was extracted using a Qiagen DNeasy kit (Qiagen, Valencia, California). For all individuals, an approximately 1100 bp fragment of the mitochondrial cytochrome *b* gene (*cyt b*) was amplified using the polymerase chain reaction (PCR) (Saiki et al. 1988). Sequences in GenBank for elf Owl (*Micrathene whitneyi*, #MWU89170), northern saw-whet owl (*Aegolius acadicus*, #AAU89172) and long-eared owl (*Asio flammeus*, #AFU89171) were used to design PCR oligonucleotide primers. The program OLIGO 6.0 (Molecular Biology Insights, Inc., Cascade, Colorado) was used to design all PCR and sequencing primers. External PCR primer sets included F14899 (5'- CCCAACATCCGAAARTCTCAC -3') and R15940 (5' - GGATGCTAGTTGGCCGATRAT - 3'). In addition to the external primers, the following internal primers were designed for nucleotide sequencing: 1) F14909 (5' - GAAAGTCTCACCCCCTGCTAA - 3'), 2) F15078 (5' - AGCCTTCACATCCGTCTCACA - 3'), 3) F15530 (5' - CATCCGACTGCGACAAGATCC - 3'), 4) R15184 (5' - GTACAGACCGCGTCCGATGTG - 3'), 5) R15542 (5' - ATGGGTGGAAGGGGATCTTGT - 3'), and 6) R15919 (5' - GATGAATGGGTGTTCTACTGG - 3'). All primer numbers refer to positions in the chicken (*Gallus gallus*) mitochondrial genome sequence.

PCR was performed in 50 μ l reaction volumes and included 2.0 μ l of 10 mM solution of each primer, 5.0 μ l of 10X reaction buffer with 20 mM MgCl, 4.0 μ l dNTP

mix (0.2 mM each), 0.2 Takara® *Ex Taq* polymerase (Fisher Scientific, Houston, Texas), and 1-2 µl of DNA template. A Hybaid® Omn-E thermocycler (Hybaid Limited, Middlesex, United Kingdom) was used for all PCR reactions. The amplification profile included: 1) an initial denaturation at 95° C for 5 min followed by denaturation at 94° C for 1 min; 2) a touchdown PCR scheme (Don et al. 1991), whereby the initial annealing temperature was 60° C for the first cycle followed by 2° C decrease per cycle for the next two cycles, and 35 cycles with a constant annealing temperature of 56° C; 3) extension at 72° C for 1 min; and 4) a final extension time at the last cycle for 72° C 4 min. All PCR experiments included negative controls, and amplification products were electrophoresed on 1.5% agarose-TBE (tris, boric acid, EDTA) gels and visualized under UV light along with appropriate size standards.

Amplified PCR products were purified using either the Edge QuickStep PCR purification kit (Edge Biosystems, Gaithersburg, Maryland) or Qiagen® PCR kits (Qiagen, Valencia, California), and sequencing reactions were done with an ABI PRISM™ dye-terminator cycle-sequencing kit (Applied Biosystems, Foster City, California). Prior to sequencing on an ABI 377 automated DNA sequencer, excess dye and primers were removed from the samples on 7.5% G-50 Sephadex spin column. All PCR fragments were sequenced for both strands, and multiple sequences for each individual were obtained for DNA isolated from both blood and tissue.

Sequencher v4.0 (Gene Codes, Ann Arbor, Michigan) was used to edit all chromatograms and create a contig from all sequences of each individual.

Analytical Procedures

Presence of potential nuclear pseudogenes (*sensu* Sorenson & Fleischer, 1996; Sorenson & Quinn, 1998) was investigated in several ways. First, sequences for each individual were obtained from both blood and other tissue sources. Second, sequences were compared against the GenBank database by BLAST (blastn and blastx) searches, and all sequences corresponded to previously reported *cyt b* sequences of pygmy-owls and related species. Third, nucleotide composition for each codon position was compared to those reported for other avian taxa (Moore & DeFilippis, 1997).

Several population statistics, including haplotype diversity (Nei 1987), nucleotide diversity (π ; Nei 1987), theta ($\theta = 2 N_e\mu$; Watterson 1975), and number of segregating sites, were estimated using DnaSP version 4.0.6 (Rozas et al. 2003). Standard error of these measurements was determined from a null distribution generated from 10,000 random permutations of the data keeping sample size constant. An analysis of molecular variance (AMOVA, Excoffier et al. 1992) was used to test for genetic structure within and between major regions identified through phylogenetic and nested clade analysis, ARLEQUIN version 2.0 software package (Schneider et al., 2000).

Patterns of mtDNA haplotypes were investigated in two ways. First, relationships among unique haplotypes were determined through both distance based analyses, using neighbor-joining (NJ, Tamura & Nei 1993) distance estimates, and maximum parsimony (MP) that employed the heuristic search option with equal weighting of characters (TBR branch swapping, stepwise random additions, and 10 replications; *PAUP** 4.0, Swofford 1999). Support for the MP trees was determined

with bootstrap replications (1,000 replications, Felsenstein 1985). Modeltest v3.06 (Posada & Crandall 1998) and the original MP tree was used to determine the appropriate model for the Bayesian analysis. A Bayesian analysis in MrBayes version 3 was performed and posterior probabilities were obtained using Markov chain Monte Carlo (MCMC) techniques (Nst = 6, Rates = gamma, Ngen = 5, 000,000, frequency = 100, chains = 4, Ronquist & Huelsenbeck 2003). Benefits of Bayesian analysis include reduced run time and, because MrBayes using Metropolis-coupled MCMC search method, avoidance of being trapped in valleys of phylogenetic tree space (Ronquist & Huelsenbeck 2003). Second, a parsimony network for all haplotypes was constructed following the procedure of Templeton et al. (1992) as implemented in TCS version 1.1.3 (Clement et al. 2000). With 0.95 statistical probability, this network provided a framework for a nested clade analysis (NCA) that employs two distance measures to quantify spatial distribution of haplotypes (Templeton et al. 1995). The clade distance (D_c), is the geographical spread of the clade (i.e., average distance from each member of the clade to the clade's geographical center). The nested clade distance (D_n), is the average distance of haplotypes or lower level clades from the geographic center of haplotypes or clades of the next nesting level (Templeton et al. 1995, Templeton 1998, 2004). Nesting of mtDNA haplotypes begins with those differing by 1-step followed by nested clades differing by an increasing number of steps, with tip clades preceding interior clades (Templeton 1998). Association between nested clades and geographic distribution was evaluated in GeoDis version 2 (Posada et al. 2000). Because the distribution of pygmy-owls in North America is limited to areas below 1,400 m in the

United States and Mexico and 1,900 m in Central America (Proudfoot & Johnson 2000), mountain ranges may constitute geographic barriers for pygmy-owl dispersal.

Therefore, options provided in Encarta[®] 2000 (Microsoft[®], Redmond, Washington) were used to determine the shortest distances between collection locations within the known distribution of pygmy-owls (Proudfoot & Johnson 2000), and to create a distance matrix for NCA (Table 2). Using the distance matrix and selecting the user-defined distance option, the “as-the-crow-flies” default distance estimate provided from strict latitude-longitude comparisons in GeoDis version 2 (Posada et al. 2000) was circumvented. Phylogeographic patterns were evaluated following procedures outlined by Crandall & Templeton (1993), Templeton (1998) and Templeton’s inference key (2004, http://inbio.byu.edu/Faculty/kac/crandall_lab/geodis.htm). Accession numbers (GenBank) for North American haplotype sequences are AY859373—AY859402.

Results

Approximately 1100 bp of the *cyt b* gene were obtained for analysis. However, due to a high frequency of ambiguous characters (n) on the 3'-end of GenBank sequences, sequences were reduced to 899 bp for analysis. MP analysis produced 17,280 equally parsimonious trees (length 469 steps, consistency index [CI] = 0.66, retention index [RI] = 0.84, rescale index [RC] = 0.57). Topologies obtained from MP, NJ, and Bayesian analysis revealed similar patterns of relationships among various haplotypes, and these relationships were not congruent with previous designations of species (Figure 2). For instance, *G. brasilianum* clustered into two separate groups.

Table 2. Pairwise distances (km) used in nested clade analysis for *Glaucidium brasilianum* from North America (n = number of samples per location). Using GeoDis 2.0 (Posada et al. 2000), pairwise genetic distances provide statistical assessment of parsimony network created and nested using TCS 1.13 (Clement et al. 2000).

| Location | n | A | B | C | D | E | F | G | H | I | J | K | L | M | N | O | P | Q | R | S | T | U | V | W | |
|----------|------------|------|------|------|------|------|------|------|------|------|------|------|------|------|------|------|------|------|------|------|------|------|-----|-----|--|
| A | Arizona 1 | (10) | | | | | | | | | | | | | | | | | | | | | | | |
| B | Arizona 2 | (4) | 67 | | | | | | | | | | | | | | | | | | | | | | |
| C | Sonora 1 | (4) | 197 | 130 | | | | | | | | | | | | | | | | | | | | | |
| D | Sonora 2 | (2) | 352 | 285 | 155 | | | | | | | | | | | | | | | | | | | | |
| E | Sinaloa 1 | (6) | 941 | 874 | 744 | 589 | | | | | | | | | | | | | | | | | | | |
| F | Sinaloa 2 | (1) | 1145 | 1078 | 948 | 793 | 204 | | | | | | | | | | | | | | | | | | |
| G | Nayarit | (5) | 1438 | 1371 | 1241 | 1086 | 497 | 293 | | | | | | | | | | | | | | | | | |
| H | Michoacan | (8) | 1856 | 1789 | 1659 | 1504 | 915 | 711 | 418 | | | | | | | | | | | | | | | | |
| I | Oaxaca 1 | (1) | 2655 | 2588 | 2458 | 2303 | 1714 | 1510 | 1217 | 799 | | | | | | | | | | | | | | | |
| J | Oaxaca 2 | (1) | 2700 | 2633 | 2503 | 2348 | 1759 | 1555 | 1262 | 844 | 45 | | | | | | | | | | | | | | |
| K | Oaxaca 3 | (4) | 2843 | 2776 | 2646 | 2491 | 1902 | 1698 | 1405 | 987 | 188 | 143 | | | | | | | | | | | | | |
| L | Oaxaca 4 | (3) | 2888 | 2821 | 2691 | 2536 | 1947 | 1743 | 1450 | 1032 | 233 | 188 | 45 | | | | | | | | | | | | |
| M | Oaxaca 5 | (2) | 2992 | 2925 | 2795 | 2640 | 2051 | 1847 | 1554 | 1136 | 337 | 225 | 80 | 35 | | | | | | | | | | | |
| N | Chiapas 1 | (1) | 3001 | 2934 | 2804 | 2649 | 2060 | 1856 | 1563 | 1145 | 346 | 302 | 166 | 139 | 140 | | | | | | | | | | |
| O | Chiapas 2 | (2) | 3103 | 3036 | 2906 | 2751 | 2162 | 1958 | 1665 | 1247 | 448 | 405 | 271 | 226 | 221 | 105 | | | | | | | | | |
| P | Chiapas 3 | (6) | 3187 | 3120 | 2990 | 2835 | 2246 | 2042 | 1749 | 1331 | 532 | 443 | 295 | 250 | 226 | 173 | 108 | | | | | | | | |
| Q | Chiapas 4 | (2) | 3332 | 3265 | 3135 | 2980 | 2391 | 2187 | 1894 | 1476 | 677 | 629 | 481 | 436 | 415 | 365 | 294 | 186 | | | | | | | |
| R | Yucatan | (1) | 3847 | 3780 | 3650 | 3495 | 2906 | 2702 | 2409 | 1991 | 1192 | 1045 | 904 | 859 | 841 | 776 | 717 | 628 | 512 | | | | | | |
| S | Tabasco | (6) | 3134 | 3067 | 2937 | 2782 | 2193 | 1989 | 1696 | 1278 | 479 | 432 | 296 | 251 | 212 | 215 | 145 | 67 | 247 | 624 | | | | | |
| T | Veracruz 1 | (8) | 3099 | 3032 | 2902 | 2747 | 2158 | 1954 | 1661 | 1243 | 444 | 401 | 259 | 214 | 180 | 306 | 281 | 249 | 459 | 824 | 200 | | | | |
| U | Veracruz 2 | (3) | 3325 | 3258 | 3128 | 2973 | 2384 | 2180 | 1887 | 1469 | 670 | 653 | 501 | 456 | 419 | 561 | 594 | 598 | 794 | 1105 | 481 | 281 | | | |
| V | Tamaulipas | (4) | 3695 | 3628 | 3498 | 3343 | 2754 | 2550 | 2257 | 1839 | 1040 | 1063 | 907 | 862 | 824 | 961 | 996 | 989 | 1127 | 1506 | 882 | 682 | 401 | | |
| W | Texas | (18) | 4133 | 4066 | 3936 | 3781 | 3192 | 2988 | 2695 | 2277 | 1478 | 1521 | 1348 | 1303 | 1281 | 1427 | 1452 | 1442 | 1643 | 1960 | 1336 | 1136 | 855 | 454 | |

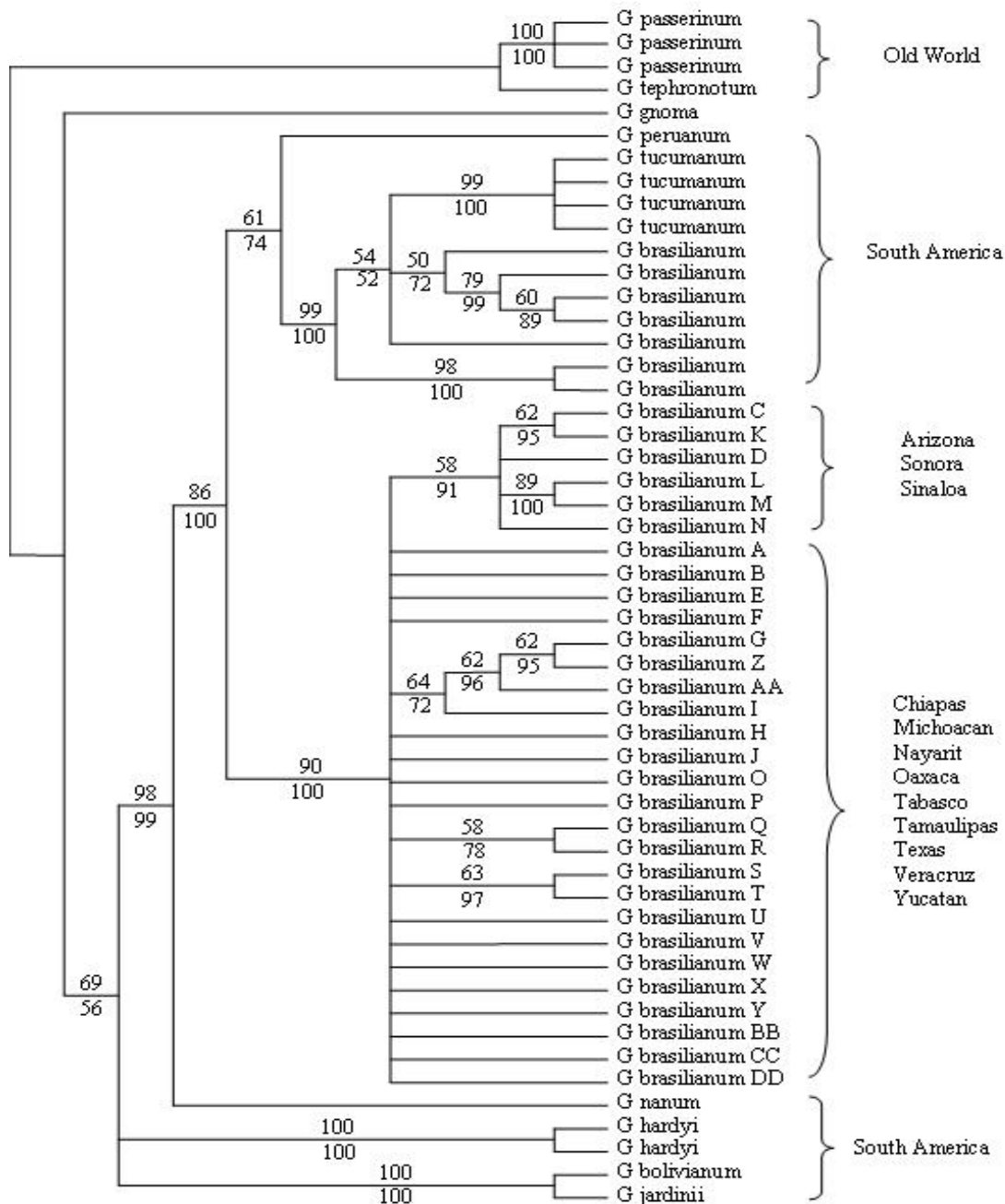

Figure 2. Genetic relationship of members of *Glaucidium* from Old and New World populations (cytochrome *b* gene). Strict consensus of 17,280 most parsimonious trees generated using MP method with heuristic search; bootstrap support (1,000 replications) is displayed above branch lines; posterior probability from Bayesian analysis is displayed below corresponding bootstrap values. Uppercase letters following “*G. brasilianum*” from North America correspond to haplotypes in Table 1 and Figure 2. North American haplotypes C, D, K, L, N, and M form an Arizona, Sonora, and Sinaloa group. The remaining North American haplotypes form a Nayarit, Michoacan, Oaxaca, Chiapas, Yucatan, Tabasco, Veracruz, Tamaulipas, and Texas group. Phylogram created using *PAUP** 4.0 (Swofford 1999).

One group contained South American haplotypes representing populations of *G. brasilianum* as well as *G. tucumanum*, and this group was sister to *G. peruanum*. Remaining haplotypes of *G. brasilianum* formed a group containing North American populations. Within this predominantly North American group, haplotypes from Arizona, Sonora, and Sinaloa formed a distinct subgroup from the remaining populations of *G. brasilianum* from Texas and Mexico (Table 1, Figure 2).

Average absolute nucleotide difference among recognized species was $8.9\% \pm 4.0\%$, and average difference with Jukes and Cantor correction was $9.6\% \pm 4.6\%$ (Table 3). Within population variance (AMOVA) of North and South America populations of *G. brasilianum* was 19.0% ($\theta_{st} = 0.81$, $P < 0.001$). AMOVA among groups in North and South America was 77.7% ($\theta_{ct} = 0.78$, $P = 0.007$), variance among populations within groups was 3.2% ($\theta_{sc} = 0.15$, $P < 0.001$).

Haplotype Diversity of North American Pygmy-Owls

Of the 103 individuals examined from Mexico and the United States, 30 unique haplotypes (approximately one in every three individuals) were revealed. Seventeen haplotypes occurred in only one individual, nine were shared by 2–6 individuals, and 3 were shared by 12, 20, and 21 individuals. Absolute sequence difference among haplotypes ranged from 1 to 11 substitutions or 0.1% to 1.0% (Table 2). Number of polymorphic sites was 30, with 16 being parsimony informative. Single variable sites included positions 10, 129, 159, 229, 246, 311, 315, 357, 358, 363, 388, 593, 789, and 876 of the chicken genome. Parsimony informative

Table 3. Below the diagonal are proportions of pairwise nucleotide substitutions between species of *Glaucidium* from Old World, North and Central and South American populations. Pairwise distances given correlate to divergence time (roughly 2% per one million years: Shields and Wilson 1987). Above the diagonal are corresponding Jukes Cantor corrected distances determined using DnaSP 4.0.6.

| Species* | (bp) | A | B | C | D | E | F | G | H | I | J | K |
|----------------------------|-------|-------|-------|-------|-------|-------|-------|-------|-------|-------|-------|-------|
| A <i>G. passerinum</i> | (899) | - | 0.115 | 0.185 | 0.158 | 0.165 | 0.180 | 0.165 | 0.164 | 0.160 | 0.167 | 0.170 |
| B <i>G. tephronotum</i> | (834) | 0.107 | - | 0.138 | 0.129 | 0.135 | 0.127 | 0.117 | 0.120 | 0.120 | 0.123 | 0.124 |
| C <i>G. gnoma</i> | (896) | 0.164 | 0.126 | - | 0.126 | 0.118 | 0.109 | 0.098 | 0.110 | 0.106 | 0.114 | 0.109 |
| D <i>G. jardinii</i> | (840) | 0.142 | 0.110 | 0.115 | - | 0.034 | 0.078 | 0.075 | 0.077 | 0.082 | 0.082 | 0.081 |
| E <i>G. bolivianum</i> | (844) | 0.148 | 0.121 | 0.109 | 0.031 | - | 0.081 | 0.078 | 0.074 | 0.080 | 0.082 | 0.092 |
| F <i>G. hardyi</i> | (893) | 0.160 | 0.119 | 0.101 | 0.074 | 0.076 | - | 0.034 | 0.071 | 0.076 | 0.080 | 0.079 |
| G <i>G. nanum</i> | (896) | 0.148 | 0.108 | 0.092 | 0.071 | 0.073 | 0.066 | - | 0.039 | 0.037 | 0.041 | 0.032 |
| H <i>G. peruanum</i> | (896) | 0.147 | 0.110 | 0.102 | 0.073 | 0.070 | 0.068 | 0.038 | - | 0.027 | 0.028 | 0.025 |
| I <i>SA-G. brasilianum</i> | (899) | 0.143 | 0.110 | 0.098 | 0.077 | 0.075 | 0.071 | 0.036 | 0.026 | - | 0.013 | 0.027 |
| J <i>G. tucumanum</i> | (898) | 0.150 | 0.113 | 0.106 | 0.077 | 0.078 | 0.076 | 0.040 | 0.028 | 0.013 | - | 0.029 |
| K <i>NA-G. brasilianum</i> | (899) | 0.153 | 0.116 | 0.104 | 0.078 | 0.077 | 0.076 | 0.033 | 0.026 | 0.027 | 0.028 | - |

*SA-*G. brasilianum* = *G. brasilianum* from South America; NA-*G. brasilianum* = *G. brasilianum* from North America.

sites included positions 60, 61, 231, 267, 268, 288, 378, 432, 603, 645, 672, 729, 738, 802, 840, and 872. Average variation per sequence (Theta-W) was 7.64, and variation per site was 0.0085. Nucleotide diversity (π) with and without Jukes and Cantor correction was 0.0043. Most substitutions (74%) occurred at the third codon position, and overall base composition was 26% A, 14% G, 39% C, and 21% T, with composition bias being highest at the third codon position and transitions accounted for 79% of the substitutions. In comparison to Mexico, with 27 haplotypes, both Arizona and Texas had extremely low levels of average haplotype diversity, with three and one haplotypes, respectively. Arizona shared one haplotype with Sonora and one haplotype with Sinaloa. No haplotypes from Arizona, Sonora, or Sinaloa were shared with the remainder of either Mexico or Texas. Texas shared one haplotype with Tamaulipas, Mexico.

Phylogeographic Patterns of Haplotype Diversity in North America

AMOVA (1023 permutations) of the two groups of *G. brasilianum* from North America showed considerably more variance (55.2%) among groups ($\theta_{ct} = 0.55$, $P = 0.007$) than variance among populations within groups, 14.1%, ($\theta_{sc} = 0.32$, $P < 0.001$). Variance within populations was 30.7% ($\theta_{st} = 0.69$, $P < 0.001$), marginally less than half the value shown between *G. brasilianum* from North and South America.

A single haplotype network (Figure 3) was obtained with TCS analysis of 103 sequences. Testing for associations between haplotype distribution and geographical location, NCA (Chi-square) identified seven clades that violated the null hypothesis of panmixia, showing significant D_c , D_n , or I-T (interior-tip nodes) values (Table 4). Inference for six of the seven clades implied restricted gene flow (RGF) with isolation by distance (IBD). For clade 1-1, significant differences in D_c and D_n values in haplotype B (geographically Tamaulipas and Texas), coupled with the known geographic distribution of pygmy-owls, indicated RGF with IBD occurred between Texas-Tamaulipas and populations in Chiapas, Michoacan, Nayarit, Oaxaca, Tabasco, and Veracruz. Significant differences in clade 1-7 occurred between tip (haplotype C, geographically Arizona and Sonora) and interior nodes (haplotype K, geographically Sinaloa and Sonora). Using the known distribution of pygmy-owls and inferences from NCA, information provided in clade 1-7 suggested RGF with IBD occurred between Arizona-Sonora and Sinaloa. Inferences for the total cladogram (4-1) yielded

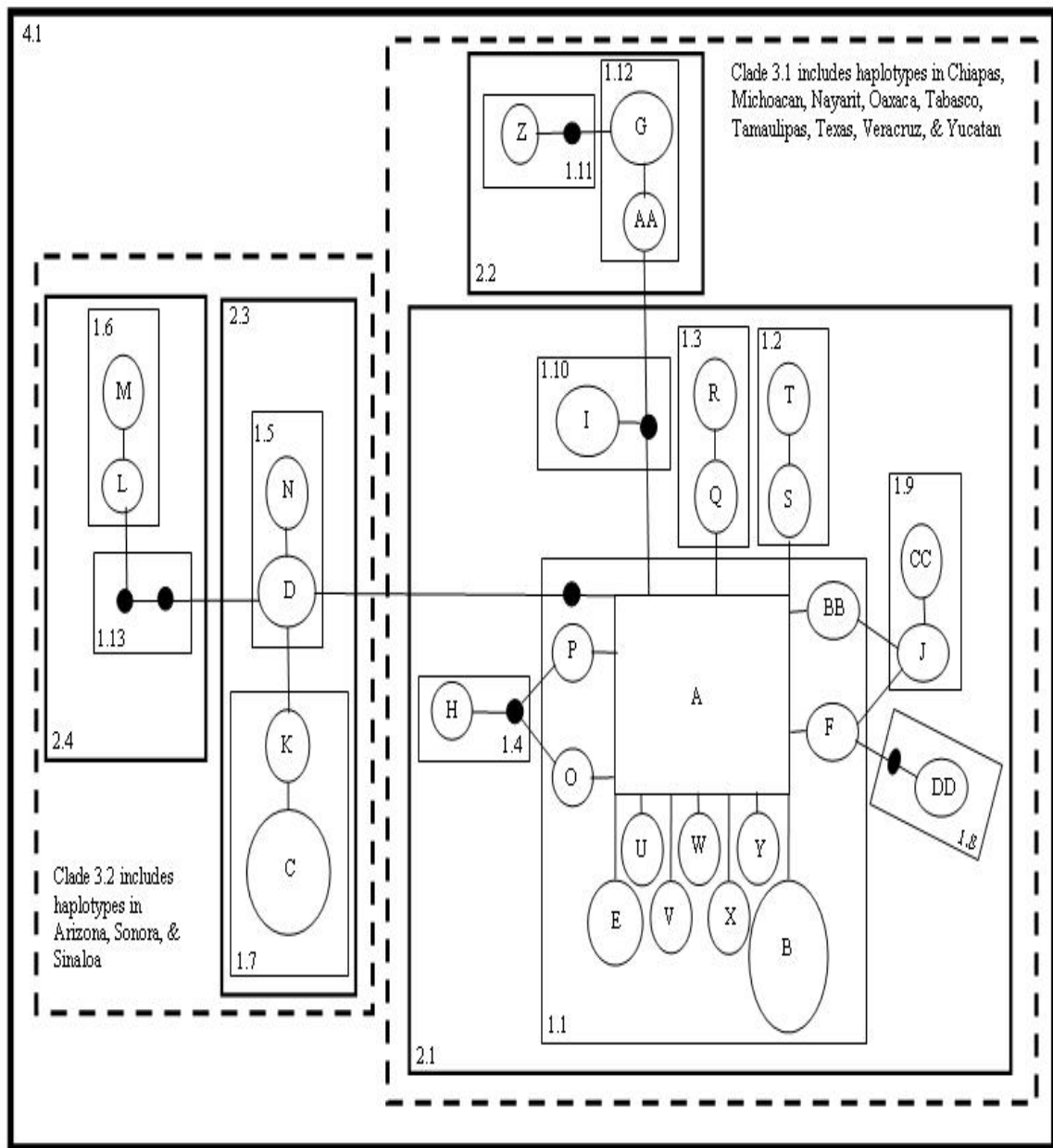

Figure 3. Haplotype network and associated nested design for nested clade analysis of North American pygmy-owls. Each branch represents a single step mutation. Black circles represent hypothetical unsampled haplotypes; lettered circles and ovals represent sampled haplotypes from North America; lettered nodes correspond to haplotypes in Table 1, geographic locations displayed in Figure 1. Size of nodes represents haplotype frequency. The lettered square “A” represents the root of the network. The level of the nested clade is given; 1-x for 1-step, 2-x for 2-step, 3-x for 3-step, and 4-x for the 4-step clade, “x” is the number identifying individual clades.

Table 4. Summation of nested clade analysis. Permutational Chi-square probabilities are germane to geographical structure of clades in Figure 2, from 1,000,000 resampling events. The probability of obtaining a chi-square value greater than or equal to the observed statistic by random chance is given as P . Clades with a probability of ≥ 0.05 were excluded from this table. Inferences were obtained following Templeton (1998) and the latest version of the inference key available online at http://bioag.byu.edu/zoology/crandall_lab/geodis.htm. Abbreviations for inferences are: RGF, restricted gene flow; IBD, isolation by distance; PF, past fragmentation.

| Clades | Permutational | | | Inference |
|-----------------------------|--------------------|--------|--------------------|--------------|
| | χ^2 statistic | P | Chain of inference | |
| Haplotypes nested in 1-1 | 273.83 | 0.005 | 1-2-3-4-NO | RGF with IBD |
| Haplotypes nested in 1-7 | 12.00 | 0.005 | 1-2-3-4-NO | RGF with IBD |
| 1-step clades nested in 2-1 | 161.39 | 0.012 | 1-2-3-4-NO | RGF with IBD |
| 1-step clades nested in 2-3 | 15.92 | <0.001 | 1-2-3-4-NO | RGF with IBD |
| 2-step clades nested in 3-1 | 27.45 | 0.083 | 1-2-3-4-NO | RGF with IBD |
| 2-step clades nested in 3-2 | 10.81 | 0.033 | 1-2-3-4-NO | RGF with IBD |
| Total cladogram | 101.00 | <0.001 | 1-2-11-17-4-9-NO | PF |

past fragmentation between clade 3-1 (geographically Chiapas, Michoacan, Nayarit, Oaxaca, Tabasco, Tamaulipas, Texas, Veracruz, and Yucatan) and clade 3-2 (geographically Arizona, Sinaloa, and Sonora). Thus, NCA supports two distinct populations in North America and suggests past fragmentation as the demographic event separating the two groups (detailed results of NCA are available from the author). In the initial TCS network, populations of *G. brasilianum* from South America were included. However, because *G. brasilianum* from South America was more than 14 steps from *G. brasilianum* from North America, South America was excluded from Figure 3 and NCA. F_{st} (Hudson et al. 1992, DnaSP 4.0.6) for the two major clades in North America was 0.32. Phylogenetically, Arizona and Texas populations are unique, with no shared haplotypes (Figures 2 & 3). Populations from Sonora and Sinaloa, Mexico, were

distinct from remaining populations in Mexico and grouped closest to haplotypes in Arizona. Similarly, populations from Texas and Tamaulipas, Mexico (haplotype B), may constitute a distinct group. Pygmy-owls from Arizona differed by as much as 1.0% from pygmy-owls in Oaxaca, Mexico, and by as much as 0.7% from pygmy-owls in Texas.

Discussion

Currently, both North and South American populations are recognized as *G. brasilianum* (AOU 1957, 1998, 2004). Nevertheless, König et al. (1999) proposed the recognition of North American population of *G. brasilianum* as a distinct species, *G. ridgwayi*. Analysis of mtDNA variation in several *Glaucidium* species supports the recommendation that populations of *G. brasilianum* from Mexico, Texas, and Arizona represent a phylogenetically distinct group from populations occurring in South America. Phylogenetic support for the recognition of *G. tucumanum* by König et al. (1999) seems less compelling.

Patterns of mtDNA variation also provide strong evidence of two genetically distinct units in North America, one in Arizona, Sonora, and Sinaloa, and the other in Texas, Tamaulipas, and regions of South-Central Mexico. These results are congruent with earlier taxonomic studies that recognized birds from these regions as distinct subspecies (van Rossem 1937, Peters 1940, Phillips 1966, König et al. 1999). Using revised nomenclature, the Arizona, Sonora, and Sinaloa group and the other group in Texas, Tamaulipas, and regions of South-Central Mexico, would be recognized as *G. r. cactorum* and *G. r. ridgwayi*, respectively. The separation is probably the consequence

of northern expansion of the pygmy-owl range and barriers to gene flow provided by the Sierra Madre Occidental and the Sierra Madre Oriental, because pygmy-owls rarely occur above 1,300 m (Proudfoot & Johnson 2000).

Hewitt (2000) proposed that decline in genetic diversity at the edge of an organism's range may be considered a signature of the magnitude and direction of population expansion. Hence, with only three haplotypes in Arizona, one haplotype in Texas, and 27 haplotypes in Mexico, results from this study indicate northern expansion and recent colonization of Arizona, Sonora, and Sinaloa, and Texas and Tamaulipas, with low levels of divergence reflecting recency of common ancestry (Hewitt 2000). Assuming an equal mutation rate of 2% per million years (MY, Schields & Wilson 1987), the separation of pygmy-owls in Arizona, Sonora, and Sinaloa from populations in Texas, Tamaulipas, and regions of South-Central Mexico occurred ca. 215,482 yrs ago during the late-Pleistocene.

Comparing two models (Dispersal-Vicariance Analysis and Brooks Parsimony analysis) and the data from Zink et al. (2000, see also Zink & Blackwell-Rago 2000, Zink et al. 2001), Brooks and McLennan (2001) observed a strong vicariant relationship between avian fauna of Baja California-California and the Sonoran Desert. In addition, moderate support was obtained for a vicariant relationship between avian fauna of Baja California-California and the Sonoran Desert and areas of the Chihuahuan Desert and Sinaloan shrubland of western Mexico. An average genetic distance of 5.1% for 35 species of North American songbird suggests that speciation of this avifauna coincides with expansion of large glacial ice sheets, climatic oscillations, and major changes in the

flora of the Northern Hemisphere (Webb & Bartlein 1992, Hewitt 1996, Klicka & Zink 1997, 1999, Cody et al. 2002). Flora of this region continued to change throughout the Pleistocene and the emergence of the Sonoran Desert (Cody et al. 2002). Hence, a combination of geographic barriers and shifting vegetation regimes, caused by environmental changes, may have restricted gene flow between populations of pygmy-owls in Arizona, Sonora, and Sinaloa and the remainder of Mexico and Texas.

Molecular studies of owls (Heidrich & Wink 1994, Heidrich et al. 1995, Barrowclough et al. 1999), and many other birds, have revealed similar geographic subdivisions (Awise 1994, Wink 1995, Wittmann et al. 1995, Wink et al. 1996, Zink et al. 1998 & 2001). Because there are distinct differences between the Arizona, Sonora, and Sinaloa populations of Mexico and other localities in Mexico and Texas, mtDNA analysis in this study indicates that pygmy-owl populations in North America represent separate management units that taxonomically can be considered two distinct subspecies. Based on the haplotypic separation that exists between the pygmy-owl populations of Arizona, Texas, and regions of South-Central Mexico, data from this study does not indicate genetic isolation between the distinct populations in the US and those immediately across the border in either Sonora or Tamaulipas, Mexico. However, because NCA implies some restricted gene flow between the Arizona-Sonora and Sinaloa population, caution should be demonstrated when developing management plans for endangered pygmy-owls in Arizona. For example, management agencies may consider excluding the Sinaloan group when estimating potential gene flow, immigration through dispersal, and projected recovery of pygmy-owls in Arizona. Because genetic

data provide a snap-shot of the past and recognition of genetically distinct units plays only one role in conservation policy (Barrowclough 1992), current demographic data should also be considered in developing management policies for pygmy-owls in Arizona.

There are relatively few examples of deep nuclear divisions without concomitant mtDNA separation (Zink 1997, Palumbi et al. 2001). However, because mtDNA restricts analysis to maternal lineages, other genomic regions (e.g., microsatellites) should be studied to test these conclusions. By examining both maternally and biparentally inherited genetic markers, one may obtain a detailed assessment of the genetic structure of pygmy owl populations. If other genetic markers, such as microsatellites, show low level genetic variation within the Arizona-Sonora population and similar geographic subdivisions among North American populations, these data should be used as guidelines for pygmy-owl recovery (task 3 of the pygmy-owl recovery plan lists genetic data as essential information for pygmy-owl management, U.S. Fish & Wildlife Service 2003). In addition, research should be conducted to determine the point of separation and to ascertain the cause of RGF with IBD within the Arizona, Sonora, and Sinaloa group. If RGF with IBD resulted from urban and agricultural expansion in Arizona, Sonora, and Sinaloa, the span of isolation was approximately 75 yrs (an extremely short time span in population genetic terms).

CHAPTER III
DEVELOPMENT AND CHARACTERIZATION OF MICROSATELLITE DNA
PRIMERS FOR FERRUGINOUS PYGMY-OWLS (*GLAUCIDIUM*
BRASILIANUM*)

Introduction

Ferruginous pygmy-owls (*Glaucidium brasilianum*) occur in Neotropical and semi-tropical lowlands from south-central Arizona south along the Pacific slope of Mexico to Nayarit, and from southeastern Texas south along the Atlantic slope of Mexico to Veracruz, extending south throughout the remainder of Mexico, Central and South America. Pygmy-owls are permanent residents throughout their range (Proudfoot & Johnson 2000) and occupy a variety of ecosystems ranging from semiarid scrub to tropical rainforest. In Mexico, Central and South America the pygmy-owl is considered common (Enríquez-Rocha et al. 1993, König et al. 1999) and was the most collected species of owl in Mexico from 1840-1991 (Enriquez-Rocha et al. 1993). Nevertheless, in the United States (U.S.) the species is listed as endangered in Arizona and was proposed for threatened status in Texas (U.S. Fish & Wildlife Service 1997). A recent study of mtDNA variation revealed low levels of haplotype diversity in Arizona and Texas populations, whereas populations from Mexico had higher diversity, suggesting either a founding event for U.S. populations or a loss of variation as a result of small effective female population sizes (Chapter II). For a detailed assessment of the genetic

*Reprinted with permission from “Development and characterization of microsatellite dna primers for ferruginous pygmy-owls (*glaucidium brasilianum*)” by Proudfoot GA, Honeycutt RL, Slack RD, 2005. Mol. Ecol. Notes **5**, 90-92. Copyright, 2005 by Blackwell Publishing Ltd.

structure of pygmy owl populations and the historical processes responsible for current patterns of genetic variation, one must examine both maternally and biparentally inherited genetic markers. Described herein are ten polymorphic microsatellite loci that will be used to examine patterns of genetic variation throughout the range of pygmy-owls in the U.S. and Mexico. Such data are essential to the design of a viable management strategy for the recovery of pygmy-owl populations in Arizona and Texas.

Methods

Fifty-seven unrelated pygmy-owls from Texas ($n = 27$), and Mexico, including the states of Tamaulipas ($n = 3$), Veracruz ($n = 11$), Tabasco ($n = 8$), Yucatan ($n = 3$), and Chiapas ($n = 5$), were sampled. König et al. (1999) considered pygmy-owls from North and South America to represent two distinct species (*G. ridgwayi* and *G. brasilianum*, respectively). Therefore, the South American population provides the consummate out-group for comparative analysis of North American populations. Eleven Argentine samples were included for testing. Genomic DNA was extracted with a DNeasy kit (Qiagen, Valencia, CA, USA), and DNA from two Texas specimens was used to construct plasmid library following the protocol of Hauswaldt and Glenn (2003). For a detailed protocol (Msat_easy_isolation.rtf) of library construction see http://www.uga.edu/srel/DNA_Laboratory/dna_protocols.htm. M13 (-21) forward and reverse primers were used to PCR amplify and sequence all positive clones. Both strands of PCR fragments were sequenced using dye-terminator cycle-sequencing kits (Applied Biosystems, Inc., Foster City, CA, USA) and an ABI 377 automated sequencer. Sequencher 4.0 (Gene Codes Corporation, Ann Arbor, MI, USA) was used to edit and

align sequences, and locus specific primers were constructed using OLIGO Version 6.8 (Molecular Biology Insights, Cascade, CO, USA). The 5'-end of each forward primer was labeled with a fluorescent marker for genotyping on an ABI 377.

Optimal PCR conditions for each locus were determined with a BioRad® (My cycler) gradient thermocycler over a range of temperatures (45–64 °C). PCR amplifications were performed in 12.5 µl reactions that included 8.55 µl ddH₂O, 0.5 µl of 10 mM of each primer, 1.25 µl of Roche® (Roche Applied Science, Indianapolis, IN) 10X reaction buffer (15 mM MgCl₂), 1.13 µl dNTP mix (0.2 mM each), 0.075 µl *Taq* polymerase (Roche®), and 0.5 µl of DNA template. PCR conditions included: initial denaturation at 94 °C for 4 min, followed by 35 cycles of denaturation for 30 s at 94 °C, annealing for 30 s at locus specific temperatures (Table 5), and an extension for 30 s at 72 °C. A final extension at 72 °C for 4 min succeeded the last cycle. PCR products were diluted in a mix of formamide and ROX 400 size standard, and genotypes were determined using Genotyper 2.5 (Applied Biosystems).

Results & Discussion

Characterization of polymorphic microsatellite loci is presented in Table 5. With the exception of the Argentine population, locus FEPO 42 was monomorphic.

Table 5. Characterization of 10 polymorphic microsatellite loci developed from ferruginous pygmy-owl DNA.

| Locus | Sequence (5'-3') | Temp. | Repeats in cloned allele | Size | Alleles | H _o | H _e |
|---------|---|-------|---|------------------|---------|----------------|----------------|
| FEPO 5 | F-GGAGATGAATCAGCAAACCTGT R-AAATTTAAACTAGCCTAGAGTCAGC | 55 | (AGAT) ₁₃ | 258 (237-281) | 13 | 0.710 | 0.758 |
| FEPO 13 | F-GATCCTGCAATGCCACTCTTG R-CCCTACAATTCCTGGATAAAGC | 55 | (AC) ₁₁ | 306 (301-311) | 5 | 0.362 | 0.514 |
| FEPO 17 | F-GGAGAGTGAATAGACAACCTC R-TGAATATAGGCTCTGTGTGTGG | 55 | (TATC) ₁₁ | 161 (141-177) | 10 | 0.640 | 0.762 |
| FEPO 18 | F-CCCCTCATTGTTTGTGCTTTGG R-TCCTGGAGATGCCATCACTAGGAAT | 55 | (GTTT) ₈ | 196 (183-215) | 10 | 0.595 | 0.614 |
| FEPO 20 | F-ATTCCAGGCTCCAATTTTTC R-AATGCACTTTGCTAGAACCT | 55 | (TG) ₂₁ | 133 (113-137) | 13 | 0.580 | 0.767 |
| FEPO 25 | F-CCATCTCTCCTGTCCTGAGC R-CCATCTCCTTCCTGTCATAGG | 55 | (TCTA) ₁₅ | 212 (180-216) | 11 | 0.613 | 0.738 |
| FEPO 27 | F-GCACATAATTTATAATACTG R-GGTCTACCTGAGCACA | 50 | (GATA) ₁₁ | 120 (100-140) | 9 | 0.697 | 0.763 |
| FEPO 39 | F-GCGTACTATACAGATACTGGG R-CCTGCACATAGTCCATCC | 55 | (GATA) ₁₁ (CATA) ₈ | 230 (203-247) | 8 | 0.674 | 0.770 |
| FEPO 42 | F-CGTATACATCGAAATAAATACC R-CGAATAAAAACATCCCTAACC | 55 | (AC) ₆ AG (AC) ₁₃ | 188 (173-195) | 9 | 0.070 | 0.100 |
| FEPO 43 | F-CGTGAAGGTAAGAGGAGCTGG R-GGAGGGAGCCTGGAAATGG | 60 | (GGAT) ₄ (AGAT) ₁₀ AGAC (AGAT) ₆ | 196 (163-227) | 16 | 0.846 | 0.880 |

Temp. = annealing temperature in °C, Size = size in base pairs of alleles and the (range), Alleles = No. alleles/locus, H_o = observed heterozygosity, H_e = expected heterozygosity, GenBank accession numbers are AY730406-AY730415.

GENEPOP (Raymond & Rousset 1995) was used to calculate expected heterozygosity (Levene's correction), test for deviation from Hardy-Weinberg (HW) equilibrium, and assay linkage disequilibrium. Analyzed by location, FEPO 18 and FEPO 25 deviated from HW in the Texas population. Highly significant ($P < 0.01$) linkage disequilibrium was detected between FEPO 17 and FEPO 18. Because samples from Texas were from a small disjunct population at the northern edge of the species range, the observed heterozygote deficiency may be due to population substructure. Mean number of alleles per loci was 10.4 ± 2.1 . Mean observed heterozygosity was 0.58 ± 0.1 . The high level of heterozygosity and success in amplifying DNA from pygmy-owl from Texas and Argentina suggests that the markers developed from this study should prove useful for assessing genetic relationships of pygmy-owls across their range. To assess the overall level of genetic variation in natural populations of pygmy-owls, the study will be expanded to include representatives from Arizona and 10 states in Mexico.

Utilizing inventory DNA from 12 sister species, cross-amplification viability of primers was tested. The procedures (e.g., extraction, PCR, etc.) followed were as with the pygmy-owl and the results from each locus are summarized in Table 6. The sample set of non-target species was small; however, the ability of these primers to amplify across several species suggests their usefulness for other genetic studies.

Table 6. Cross-species amplification using microsatellite loci designed in ferruginous pygmy-owl.

| Species | n | Locus | | | | | | | | | |
|------------------------------|---|-------|----|----|----|----|----|----|----|----|----|
| | | 5 | 13 | 17 | 18 | 20 | 25 | 27 | 39 | 42 | 43 |
| <i>Strix viria</i> | 1 | P | M | P | M | NA | M | M | NA | P | NA |
| <i>Aegolius funereus</i> | 1 | P | M | NA | M | NA | M | M | NA | M | M |
| <i>Athene canicularia</i> | 1 | NA | M | M | M | NA | M | NA | NA | P | NA |
| <i>Tyto alba</i> | 1 | M | M | NA | M | NA | NA | NA | NA | P | P |
| <i>Megascops asio</i> | 4 | P | M | M | M | NA | M | NA | NA | P | M |
| <i>Otus flammeolus</i> | 2 | P | M | P | M | NA | NA | NA | NA | P | NA |
| <i>Strix nebulosa</i> | 2 | NA | M | M | M | NA | M | M | NA | P | NA |
| <i>Asio otus</i> | 1 | NA | NA | M | M | NA | NA | P | NA | P | NA |
| <i>Glaucidium gnoma</i> | 4 | P | M | P | M | NA | P | P | NA | M | P |
| <i>Aegolius acadicus</i> | 4 | P | M | NA | M | NA | M | P | NA | P | P |
| <i>Megascops kennicottii</i> | 3 | P | M | NA | M | NA | NA | NA | NA | P | P |
| <i>Megascops trichopsis</i> | 2 | P | M | NA | NA | NA | M | NA | NA | P | P |

Locus = microsatellite loci developed from ferruginous pygmy-owl DNA (5 = FEPO 5, 13 = FEPO 13, 17 = FEPO 17, 18 = FEPO 18, 20 = FEPO 20, 25 = FEPO 25, 39 = FEPO 39, 42 = FEPO 42, 43 = FEPO 43); P = polymorphic; M = monomorphic; NA = no successful amplification.

CHAPTER IV

VARIATION IN DNA MICROSATELLITES OF THE FERRUGINOUS PYGMY- OWL (*GLAUCIDIUM BRASILIANUM*)

Introduction

The ferruginous pygmy-owl (*Glaucidium brasilianum*), is a broadly distributed cavity-nesting species, whose historical distribution includes populations extending from south-central Arizona south along the Pacific slope of Mexico to Nayarit, as well as portions of southeastern Texas and the Atlantic slope of Mexico to Veracruz, southern states of Mexico and Central and South America (Ridgway 1914, Johnsgard 1988, 2002; Proudfoot & Johnson 2000). In the continental United States (U.S.) ferruginous pygmy-owl habitat has been reduced as a consequence of land-use practices, resulting in habitat fragmentation and an overall decline of populations in Arizona and Texas (Oberholser 1974, Johnson et al. 1979, U.S. Fish & Wildlife Service 1997). Currently, populations are listed as endangered in Arizona and were proposed for threatened status in Texas (U.S. Fish & Wildlife Service 1997). According to surveys conducted from 1999 to 2001, fewer than 50 adult ferruginous pygmy-owls were known to exist in Arizona during any one year (U.S. Fish & Wildlife Service 2003).

One primary goal of the recovery plan for the ferruginous pygmy-owl in the U.S. (especially Arizona) is the assessment of overall genetic variation in existing populations in both the United States and neighboring regions in Mexico. These data are deemed essential for two reasons. First, management units need to be objectively defined. Second, current levels of genetic variation are required for the proper

application of plans related to the maintenance of genetic variability and population viability in regions that have experienced recent declines (U.S. Fish & Wildlife Service 2003).

A recent study of mitochondrial DNA (mtDNA) variation in the ferruginous pygmy-owl has provided valuable information on both taxonomic status of particular populations and the historical demography of ferruginous pygmy-owl populations in the continental U.S. (König 1999, Chapter II). Rather than recognition of a single species, *G. brasilianum*, phylogenetic assessment of nucleotide sequences derived from the mitochondrial cytochrome *b* gene, suggests a major separation of ferruginous pygmy-owls into two species, *G. ridgwayi* representing the population in Arizona, Texas, and Mexico, and *G. brasilianum* distributed throughout South America. In addition, a recent study by Proudfoot (Chapter II) suggests a separation of populations *G. ridgwayi* into two subspecies, *G. r. ridgwayi* (Texas, Tamaulipas, and regions of South-Central Mexico) and *G. r. cactorum* (Arizona, Sonora, and Sinaloa). Furthermore, these data imply somewhat different phylogeographic histories for populations in Arizona and Texas resulting in two separate potential management units in the continental U.S., both of which were derived from different ancestral stocks in Mexico. From hereafter, I will refer to the study species as pygmy-owl(s).

Although the current mtDNA data denote clear patterns of phylogeographic variation, inference is restricted to the maternal lineage, and as shown by several studies, patterns of geographic variation from biparentally inherited genetic markers can deviate from those revealed by mtDNA markers (Barrowclough and Gutiérrez 1990,

Barrowclough 1992, Haig & Avise 1995, Chan and Arcese 2002, Eggert et al. 2004, Martinez-Cruz et al. 2004). Therefore, an accurate assessment of patterns of gene flow between the U.S. and populations to the south as well as an evaluation of management units requires detailed genetic information from nuclear markers.

In this study, I examine patterns of genetic variation at 11 polymorphic loci, 10 of which were isolated from the pygmy-owl (Proudfoot et al. 2005) and one from the Mexican spotted owl (Thode et al. 2002). Microsatellite markers exhibit high levels of genetic variation and have proven useful for detailed genetic studies within avian species (Barrowclough and Gutiérrez 1990, Larson et al. 2002, Pérez et al. 2002, Wisely et al. 2002, Csiki et al. 2003). In addition, they tend to reveal higher levels of overall genetic variation in populations previously characterized as having low mtDNA haplotype diversity (Kirchman et al. 2000, Pérez et al. 2002, Muwannika et al. 2003, Bhagabati et al. 2004). Therefore, results from these biparentally inherited markers in combination with mtDNA variation should provide a more detailed assessment of geographic variation and patterns of gene flow, especially as these data relate to the establishment of management units.

Methods

Sampling

One-hundred seventy-three specimens of pygmy-owls were examined from Arizona ($n = 44$), Mexico ($n = 96$), and Texas ($n = 33$). I collected samples from Arizona and Texas during concurrent pygmy-owl natural history studies conducted from 1994-2004. In Mexico, I sampled pygmy-owls from: Sonora ($n = 17$), in the proximity

of El Patricio, El Sasabe, La Reforma, Magnalena de Kino, Hermosillo, and the southeastern reaches of the Río Yaqui; Sinaloa ($n = 10$) along the Río Tamazula near (ca. 15 km to 25 km) Culiacán; and Nayarit ($n = 5$) in proximity (ca. 10 km to 15 km) to Laguna Laguna at Santa Maria del Oro. Whole blood and tissue biopsies were collected from feather pulp derived from pygmy-owls collected in Arizona and Texas, U.S., and in Nayarit, Sinaloa, and Sonora, Mexico. Museums provided alcohol preserved and dry (toe pad) tissue samples from: Chiapas ($n = 8$), Michoacan ($n = 10$), Nayarit ($n = 1$), Oaxaca ($n = 13$), Sinaloa ($n = 4$), Tabasco ($n = 10$), Tamaulipas ($n = 3$), Veracruz ($n = 12$), and Yucatan ($n = 3$), Mexico (Figure 4). Accession numbers for samples provided by the University of California Museum of Vertebrate Zoology at Berkeley included MVZFC 22474-22575 and MVZFC 20006.

Data Collection

Genomic DNA was extracted with a DNeasy kit (Qiagen, Valencia, CA, USA) following the manufacture's protocol. Ten polymorphic loci designed for pygmy-owls (Proudfoot et al. 2005) and one locus (4E10.2) from the Mexican spotted owl (Thode et al. 2002) were used to derive a genotype for each individual and assess genetic variation within and between all populations. The 5'-end of each forward primer was labeled with a fluorescent marker for genotyping on an ABI 377 (Applied Biosystems, Foster City, California) automated DNA sequencer. Optimal PCR (polymerase chain reaction) conditions for each locus were determined with a BioRad® (My cycler) gradient thermocycler over a range of temperatures (45–64 °C). PCR amplifications were performed in 12.5 μ l reactions that included 8.55 μ l ddH₂O, 0.5 μ l of 10 mM of each

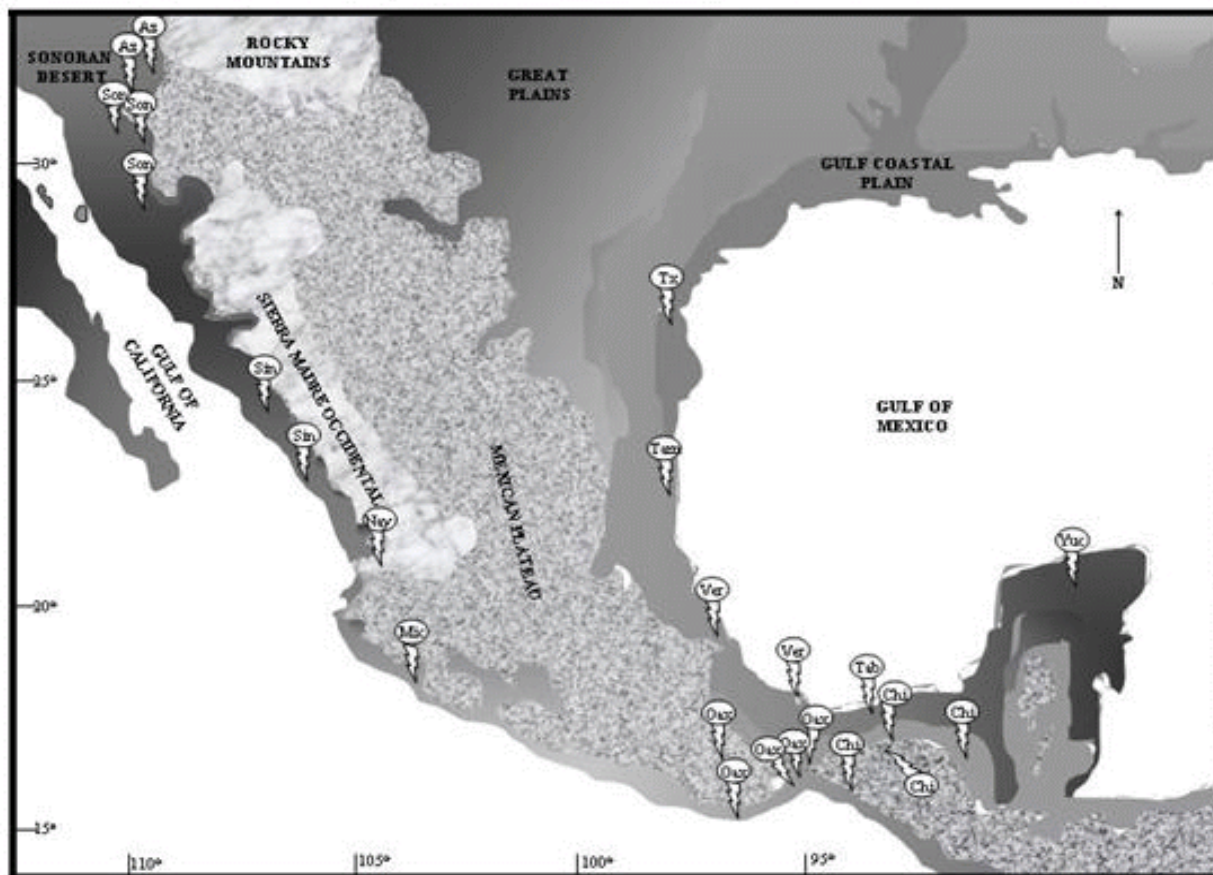

Figure 4. Location of collection sites for North American *G. brasilianum*. The tips of lighting-bolts correspond to within one minute of both latitude and longitude of sample areas (Az = Arizona, Chi = Chiapas, Mic = Michoacan, Nay = Nayarit, Oax = Oaxaca, Sin = Sinaloa, Son = Sonora, Tab = Tabasco, Tam = Tamaulipas, Tx = Texas, Ver = Veracruz, and Yuc = Yucatan).

primer, 1.25 μ l of Roche® (Roche Applied Science, Indianapolis, IN) 10X reaction buffer (15 mM MgCl₂), 1.13 μ l dNTP mix (0.2 mM each), 0.075 μ l *Taq* polymerase (Roche®), and 0.5 μ l of DNA template. PCR conditions included: initial denaturation at 94 °C for 4 min, followed by 35 cycles of denaturation for 30 s at 94 °C, annealing for 30 s at locus specific temperatures (Table 7), and an extension for 30 s at 72 °C. A final extension at 72 °C for 4 min succeeded the last cycle. PCR products were diluted in a mix of formamide and ROX 400 size standard, and genotypes were determined using Genotyper 2.5 (Applied Biosystems).

Analytical Procedures

One-hundred eighty-six individuals were genotyped for 11 loci. Twenty-five samples were incomplete, missing one locus per individual (5 from Arizona, 2 from Chiapas, 1 from Nayarit, 1 from Sinaloa, 4 from Sonora, 2 from Tabasco, 8 from Texas, 1 from Veracruz, 1 from Yucatan). GENEPOP version 3.4 (Raymond & Rousset 1995a) was used to calculate expected heterozygosity (Levene's correction) and test for deviation from Hardy-Weinberg equilibrium (HWE), including heterozygote excess and deficiency. The exact test of Haldane (1954) and Weir (1990) was used to test every locus in each population for departure from HWE, and *P*-values were estimated using the Markov-chain method (Guo & Thompson 1992), following program defaults (dememorization = 1,000, batches = 100, iterations = 1,000). Genic and genotypic differentiation among populations and linkage disequilibrium also were assayed using GENEPOP 3.4 (Raymond & Rousset 1995a). Fisher's exact test and the Markov-chain method were used to assay linkage disequilibrium between loci, the null hypothesis

Table 7. Characterization of 11 polymorphic loci used to assay genetic variation in pygmy-owls. Allele range refers to the base pair size of the observed alleles, heterozygosity observed is H_o , heterozygosity expected is H_e .

| Locus | Repeats in cloned allele | Annealing temp. | Allele range | No. of alleles | H_o | H_e |
|---------|---|-----------------|--------------|----------------|-------|-------|
| FEPO 5 | (AGAT) ₁₃ | 55 | 156-281 | 17 | 0.702 | 0.778 |
| FEPO 13 | (AC) ₁₁ | 55 | 301-311 | 4 | 0.333 | 0.495 |
| FEPO 17 | (TATC) ₁₁ | 55 | 141-173 | 9 | 0.604 | 0.739 |
| FEPO 18 | (GTTT) ₈ | 55 | 183-215 | 8 | 0.544 | 0.602 |
| FEPO 20 | (TG) ₂₁ | 55 | 113-137 | 12 | 0.634 | 0.786 |
| FEPO 25 | (TCTA) ₁₅ | 55 | 180-212 | 10 | 0.618 | 0.740 |
| FEPO 27 | (GATA) ₁₁ | 50 | 100-140 | 9 | 0.667 | 0.763 |
| FEPO 39 | (GATA) ₁₁ (CATA) ₈ | 55 | 223-243 | 7 | 0.636 | 0.754 |
| FEPO 42 | (AC) ₆ AG (AC) ₁₃ | 55 | 173-191 | 6 | 0.023 | 0.058 |
| FEPO 43 | (GGAT) ₄ (AGAT) ₁₀ AGAC (AGAT) ₆ | 60 | 163-227 | 14 | 0.851 | 0.878 |
| 4E10.2 | (ATTTT) ₆ | 55 | 131-181 | 9 | 0.626 | 0.698 |

being that genotypes at two different loci are independent of one another (Raymond & Rousset 1995b). Genic and genotypic differentiation were tested with Fisher's exact test (Raymond & Rousset 1995b) and with the G based exact test described by Goudet et al. (1996), respectively. Using the log-likelihood G statistics and selecting genotypic permutation instead of allele permutations, the test does not require the population to be in HWE (Goudet et al. 1996).

An analysis of molecular variance (AMOVA, Excoffier et al. 1992) was used to test for genetic structure within and between populations. AMOVA was calculated following procedures in GenAlEx 5.0 (Peakall & Smouse 2001). F -statistics (Wright 1931) and R_{st} -statistics (Slatkin 1995) were used to assess population differentiation,

with 999 permutations performed for each test. These analyses use estimates of the total percentage variance to determine both differences between populations within regions and differences among individuals within populations, as well as to assess regional differences among populations. Weir & Cockerham's (1984) θ , an analogue to Wright's (1931) F_{st} , was calculated under the infinite allele model (IAM). Because IAM assumes all alleles are equally likely and equally distant from one another, IAM may not be the most appropriate model for microsatellite data analysis (Kirchman et al. 2000, Maroja et al. 2003). However, when analyzing a moderate sample size ($n \leq 50$) with a small number of alleles, Gaggiotti et al. (1999) showed that F_{st} provided a better estimate of gene flow than R_{st} . Samples were grouped according to collection locations defined by political boundaries (e.g., Arizona, Sonora, etc.). Because less than 50 individuals were collected from each sample area, F_{st} was used for comparative purposes. The stepwise mutation model's (SMM) calculation of θ_{st} , which is an analogue to Slatkin's (1995) R_{st} (see Michalakis & Excoffer 1996), is considered more appropriate than IAM for analyzing microsatellite data for levels of genetic variation and population structure (Kirchman 2001, Pérez et al. 2002). Because the SMM uses a distance matrix based on the squared differences in the number of base pairs (required to adjust for the ambiguous effect of complex and compound loci), rather than the number of repeats, it violates assumption of a strict stepwise model and may not be appropriate for estimations of overall gene flow (Kirchman et al. 2000). Because the level of difference between IAM and SMM is unknown for this data, both IAM and SMM were used for comparative purposes. To avoid possible distortions resulting from the Wahlund effect, populations

were tested separately. Fixation indexes and estimations of inbreeding were also calculated with GenAlEx 5.0 (Peakall & Smouse 2001).

Assignment tests, frequency based (Paetkau et al. 1995, 2004) and Bayesian-based (Rannala & Mountain 1997), were performed in GeneClass2 (Piry et al. 1999) under Monte-Carlo simulation with 10,000 permutations. These tests employ the log-likelihood approach to assign individuals to defined populations based on genotype. An assignment match results from an individual being accurately assigned to its assumed population of origin rather than to an alternative population. Extensive gene flow is indicated by a significant number of mismatches. Sampling was performed in two ways: 1) according to collection location, and 2) based on subspecies boundaries established in Chapter II (*G. r. ridgwayi* & *G. r. cactorum*).

Populations with a recent reduction in effective population size show corresponding reductions in allele number and gene diversity at polymorphic loci. Because the allele number in bottlenecked populations is reduced faster than the gene diversity, comparisons of observed and expected gene diversity can provide inference to populations that have experienced a recent bottleneck (Piry et al. 1999). Bottleneck (Piry et al. 1999) and TPM (Two-phase model) were used to determine whether or not the Arizona and Texas populations experienced recent population declines. The TPM is thought to most closely simulate microsatellite mutation (Primmer et al. 1998, Estoup & Cornuet 2000). Unlike the SMM, which predicts all mutations as single base-pair repeats, the TPM predicts an occasional multiple base-pair repeat may occur (Bellinger et al. 2003). To test the significance of the analysis, we used a one-tailed Wilcoxon

sign-rank test. The Wilcoxon sign-rank test can be used with few loci and individuals and still provide a relatively high power of resolution (Maroja et al. 2003, Muwanika et al. 2003). In addition to assessing recent reductions in population numbers with Bottleneck (Piry et al. 1999), effective population size (N_e) was estimated using NeEstimator (Peel et al. 2000). Because data were collected over several years in Arizona, Sonora, and Texas, moments based temporal (Waples 1989) and linkage disequilibrium models (Hill 1981) were used to obtain comparative estimates of N_e .

Relationships among sampling localities were determined using several methods, including Nei's (1972, 1978) unbiased genetic distance (D_s), Goldstein's $(\delta\mu)^2$ (Goldstein et al. 1995), and negative logarithm of the proportion of shared alleles (D_{ps}) (Bowcock et al. 1994). Goldstein's $(\delta\mu)^2$ estimates the squared differences in average allele size between populations. Nei's D_s uses allele frequency to measure genetic divergence between populations (Nei 1978), where both D_s and $(\delta\mu)^2$ accommodate small sample sizes. Jin et al. (2000), however, showed that $(\delta\mu)^2$ was more reliable at distinguishing groups from different continents for larger data sets than it was for smaller ones. Comparing the performance of these distance measures, $(\delta\mu)^2$ is considered more appropriate for assessing relationships between very distant populations, while D_s is more suited for resolving fine-scale population differentiation (Paetkau et al. 1997, Takezaki & Nei 1996, Pérez et al. 2002). For microsatellite data, $(\delta\mu)^2$ assumes a direct correlation between the difference in repeat scores and the amount of time passed since different alleles shared a common ancestral allele, making allele differentiation linear with time (Goldstein et al. 1995). The sample set of pygmy-

owls contains individuals from a wide geographic area that may contain several distinct populations. However, the focus of this study is to assess genetic relationships and measure gene flow between populations in the US, where the species is listed as endangered, and populations in Mexico, where the species is considered common. Therefore, both D_s and $(\delta\mu)^2$ were used for comparative analysis. D_{ps} provides the mean of the minima of the relative frequencies of all alleles within the units being compared, either populations or individuals (Bowcock et al. 1994). MICROSAT (Minch 1995) was used to calculate D_s , D_{ps} , and $(\delta\mu)^2$. Neighbor-joining (NJ) and unweighted-pair-group method analysis (UPGMA) in PAUP* 4.0 (Swofford 1999) were used to produce phylograms derived from these varying distance matrixes.

Results

Population Statistics

Average number of alleles per locus and heterozygosity (\pm SD) observed was 9.55 ± 3.67 and 0.57 ± 0.22 , respectively (Table 7), and number of alleles per population averaged 44.85 ± 11.07 . Heterozygosity per locus across populations averaged 0.58 ± 0.28 (Table 8). Average heterozygosity for populations in Arizona (0.55 ± 0.21) and Texas (0.52 ± 0.26) were similar to other populations. Private alleles were found in Arizona (3), Chiapas (3), Michoacan (2), Oaxaca (1), Sinaloa (2), Sonora (1), Texas (10), and Veracruz (1). Fixation indexes ranged from -0.176 to 0.126 (Table 9). The fixation index for Arizona (0.126) was the highest of all populations, indicating a comparatively elevated level of inbreeding within the Arizona population.

Bonferroni corrections (Rice 1989) for multiple comparisons were applied to

test for HWE, linkage disequilibrium, and genic and genotypic differentiation. FEPO 25 was the only locus found to deviate from HWE when tested across all populations, and of the 13 populations examined, Arizona, Sonora and Texas showed heterozygote deficiency. No population and locus combinations showed heterozygote excess after Bonferroni correction. Two of the 55 possible paired combinations of loci revealed violation of linkage disequilibrium across all populations, and no loci were in linkage equilibrium within populations ($P < 0.05$). Genotypic and genic differentiation was significant across populations ($\chi^2 = \infty$, $df = 22$, $P < 0.0001$). Fifty-three of 78 possible combinations of paired populations revealed genic differentiation, and 55 pairs of populations showed genotypic differentiation ($P < 0.05$).

Tests for Genetic Subdivision

Both R_{st} and F_{st} values revealed evidence of population subdivision, with all F_{st} values greater than zero (Table 10). Overall average R_{st} and F_{st} values were 0.086 ± 0.117 and 0.059 ± 0.043 , respectively. Texas and Arizona, respectively, revealed the highest average F_{st} (0.125) and R_{st} (0.120) relative to all populations. Texas and Tamaulipas showed the lowest average R_{st} (0.030) score. Analyses employing AMOVA under both the IAM and the SMM, showed high levels variation within populations (IAM: 91%, $P = 0.001$; SMM: 94%, $P = 0.046$) relative to among

Table 8. Heterzygosity observed in pygmy-owls, by population (n) and locus.

| Pop. | n | Microsatellite loci | | | | | | | | | | Mean | |
|------|----|---------------------|---------|---------|---------|---------|---------|---------|---------|---------|---------|-------|--------------|
| | | FEPO 5 | FEPO 13 | FEPO 17 | FEPO 18 | FEPO 20 | FEPO 25 | FEPO 27 | FEPO 39 | FEPO 42 | FEPO 43 | | 4E10.2 |
| Az | 44 | 0.500 | 0.477 | 0.523 | 0.545 | 0.581 | 0.545 | 0.636 | 0.591 | 0.048 | 0.952 | 0.636 | 0.549 |
| Chi | 8 | 0.875 | 0.167 | 0.625 | 0.875 | 0.875 | 0.500 | 0.500 | 0.250 | 0.000 | 0.750 | 0.125 | 0.504 |
| Mic | 10 | 0.300 | 0.300 | 0.600 | 0.600 | 0.900 | 0.700 | 1.000 | 0.800 | 0.000 | 1.000 | 1.000 | 0.655 |
| Nay | 6 | 0.883 | 0.333 | 0.833 | 0.333 | 0.667 | 1.00 | 0.600 | 0.667 | 0.000 | 0.833 | 0.667 | 0.615 |
| Oax | 14 | 0.857 | 0.231 | 0.643 | 0.714 | 0.714 | 0.643 | 0.786 | 0.643 | 0.000 | 0.929 | 0.714 | 0.615 |
| Sin | 14 | 0.857 | 0.357 | 0.714 | 0.571 | 0.714 | 0.714 | 0.538 | 0.786 | 0.000 | 0.857 | 0.714 | 0.620 |
| Son | 17 | 0.765 | 0.471 | 0.688 | 0.250 | 0.824 | 0.471 | 0.412 | 0.588 | 0.059 | 0.533 | 0.647 | 0.519 |
| Tab | 10 | 0.800 | 0.250 | 0.400 | 0.500 | 0.900 | 0.600 | 0.600 | 0.600 | 0.000 | 0.900 | 0.800 | 0.577 |
| Tam | 3 | 0.333 | 0.667 | 0.333 | 0.667 | 0.667 | 1.00 | 0.667 | 0.667 | 0.000 | 1.000 | 0.333 | 0.576 |
| Tx | 33 | 0.774 | 0.129 | 0.636 | 0.438 | 0.364 | 0.606 | 0.788 | 0.727 | 0.30 | 0.781 | 0.484 | 0.523 |
| Ver | 12 | 0.917 | 0.273 | 0.750 | 0.833 | 0.500 | 0.667 | 0.667 | 0.750 | 0.000 | 0.833 | 0.750 | 0.631 |
| Yuc | 3 | 1.000 | 0.500 | 0.333 | 0.667 | 0.667 | 0.667 | 1.000 | 0.000 | 0.000 | 1.000 | 0.333 | 0.561 |

Pop. = collection areas (Az = Arizona, Chi = Chiapas, Mic = Michoacan, Nay = Nayarit, Oax = Oaxaca, Sin = Sinaloa, Son = Sonora, Tab = Tabasco, Tam = Tamaulipas, Tx = Texas, Ver = Veracruz, and Yuc = Yucatan).

Table 9. Allelic patterns across pygmy-owl populations (n).

| | Populations | | | | | | | | | | | |
|-----------------------|--------------|-------|--------|--------|--------|--------|-------|--------|--------|--------------|--------|--------|
| | Az | Chi | Mic | Nay | Oax | Sin | Son | Tab | Tam | Tx | Ver | Yuc |
| | (44) | (8) | (10) | (6) | (13) | (14) | (17) | (10) | (3) | (33) | (12) | (3) |
| Number of alleles | 58 | 47 | 48 | 39 | 51 | 55 | 52 | 46 | 29 | 69 | 56 | 33 |
| Alleles/locus | 5.27 | 4.27 | 4.36 | 3.55 | 4.54 | 5.00 | 4.73 | 4.18 | 2.64 | 6.27 | 5.09 | 3.00 |
| Private alleles/locus | 0.27 | 0.27 | 0.18 | 0.00 | 0.09 | 0.18 | 0.18 | 0.00 | 0.00 | 0.91 | 0.09 | 0.00 |
| Mean fixation index | 0.126 | 0.075 | -0.002 | -0.110 | -0.027 | -0.054 | 0.096 | -0.051 | -0.176 | 0.093 | -0.035 | -0.073 |

Populations = collection areas (Az = Arizona, Chi = Chiapas, Mic = Michoacan, Nay = Nayarit, Oax = Oaxaca, Sin = Sinaloa, Son = Sonora, Tab = Tabasco, Tam = Tamaulipas, Tx = Texas, Ver = Veracruz, and Yuc = Yucatan).

Table 10. Pairwise *Rst* (below diagonal) and *Fst* (above diagonal) values for pygmy-owl populations (n), calculated from 11 polymorphic microsatellite loci.

| | Az | Chi | Mic | Nay | Oax | Sin | Son | Tab | Tam | Tx | Ver | Yuc |
|------|--------------|--------------|--------------|--------------|--------------|--------------|--------------|--------------|--------------|--------------|--------------|--------------|
| Pop. | (44) | (8) | (10) | (6) | (13) | (14) | (17) | (10) | (3) | (33) | (12) | (3) |
| Az | | 0.080 | 0.074 | 0.072 | 0.072 | 0.035 | 0.031 | 0.087 | 0.065 | 0.140 | 0.080 | 0.092 |
| Chi | 0.315 | | 0.090 | 0.089 | 0.004 | 0.023 | 0.103 | 0.015 | 0.007 | 0.142 | 0.009 | 0.012 |
| Mic | 0.027 | 0.202 | | 0.026 | 0.064 | 0.064 | 0.058 | 0.091 | 0.117 | 0.143 | 0.071 | 0.127 |
| Nay | 0.073 | 0.157 | 0.114 | | 0.100 | 0.025 | 0.044 | 0.133 | 0.087 | 0.154 | 0.081 | 0.115 |
| Oax | 0.035 | 0.076 | 0.016 | 0.016 | | 0.042 | 0.092 | 0.004 | 0.027 | 0.117 | 0.011 | 0.020 |
| Sin | 0.037 | 0.252 | 0.036 | 0.000 | 0.033 | | 0.055 | 0.054 | 0.031 | 0.114 | 0.034 | 0.070 |
| Son | 0.011 | 0.176 | 0.010 | 0.025 | 0.024 | 0.026 | | 0.103 | 0.076 | 0.141 | 0.087 | 0.110 |
| Tab | 0.223 | 0.000 | 0.140 | 0.103 | 0.028 | 0.173 | 0.119 | | 0.064 | 0.112 | 0.001 | 0.034 |
| Tam | 0.000 | 0.071 | 0.000 | 0.058 | 0.000 | 0.009 | 0.000 | 0.033 | | 0.081 | 0.012 | 0.031 |
| Tex | 0.042 | 0.073 | 0.000 | 0.004 | 0.000 | 0.014 | 0.021 | 0.039 | 0.000 | | 0.077 | 0.158 |
| Ver | 0.063 | 0.061 | 0.028 | 0.030 | 0.000 | 0.049 | 0.024 | 0.010 | 0.000 | 0.000 | | 0.016 |
| Yuc | 0.494 | 0.000 | 0.422 | 0.300 | 0.156 | 0.483 | 0.288 | 0.000 | 0.190 | 0.141 | 0.145 | |

Pop. = collection areas (Az = Arizona, Chi = Chiapas, Mic = Michoacan, Nay = Nayarit, Oax = Oaxaca, Sin = Sinaloa, Son = Sonora, Tab = Tabasco, Tam = Tamaulipas, Tx = Texas, Ver = Veracruz, and Yuc = Yucatan). AMOVA procedure follows Excoffer et al. (1992), and others (see Peakall & Smouse 2001).

populations (IAM: 9%, SMM: 6%).

Assignment tests of Rannala & Mountain (1997, Bayesian method, 10,000 permutations) and Paetkau et al. (1995, 2004, frequency method, 10,000 permutations) showed little differentiation, with only 61% and 51% of all pygmy-owls correctly assigned across all populations, respectively. Most of the discrepancy was in populations from southwestern, south-central, and southeastern Mexico, all of which appeared panmictic. Populations from Arizona and Texas consistently scored the

highest percentages of correctly assigned individuals, 89% and 85% with Bayesian method, and 84% and 91% respectively with the frequency method (see Table 11 for Bayesian results). Mismatched pygmy-owls were most often assigned to geographic neighboring populations in a north-south and east-west pattern, possibly indicating stepping-stone dispersal (Kimura 1953). When populations were grouped according to subspecies (*G. r. cactorum* & *G. r. ridgwayi*), the percentage of correctly assigned pygmy-owls increased to 86% and 84% for Bayesian and frequency methods, respectively. Most of the discrepancy was in populations from southwestern, south-central, and southeastern Mexico, with 89% and 85% of mismatches found in *G. r. ridgwayi*, the subspecies that is distributed throughout southwestern, south-central, and southeastern Mexico. When the number of first generation migrants (FGM, Paetkau et al. 1995) was calculated by subspecies, one FGM occurred in the *G. r. cactorum* group and six FGM occurred in the *G. r. ridgwayi* group.

NJ and UPGMA methods produced trees with somewhat different branching orders for *Dps*, *Ds*, and $(\delta)^2$ distance measure matrixes (trees not shown). For example, NJ trees created from *Ds* and *Dps* matrixes consistently linked geographic neighboring populations in a stepwise fashion, whereas trees created from the $(\delta)^2$ matrix often linked populations at opposite ends of the pygmy-owl's distribution (e.g., Arizona to Tabasco). The discrepancy between IAM and SMM may result from small sample size (Jin et al. 2000) or the affect of compound and complex loci in this study. The SMM

Table 11. Assignment of pygmy-owls based upon Rannala and Mountain's (1997) assignment test. Numbers indicate proportional distribution of source population; source populations are horizontal, assigned populations are vertical. (10,000 permutations)

| | Az | Son | Sin | Nay | Mic | Oax | Chi | Yuc | Tab | Ver | Tam | Tx |
|------|------|------|------|------|------|------|------|------|------|------|------|------|
| Pop. | (44) | (17) | (14) | (6) | (10) | (13) | (8) | (3) | (10) | (12) | (3) | (33) |
| Az | 0.89 | 0.24 | - | 0.17 | - | - | - | - | - | 0.08 | - | 0.03 |
| Son | 0.07 | 0.47 | - | 0.17 | - | - | - | - | - | - | - | - |
| Sin | 0.02 | 0.18 | 0.71 | 0.17 | 0.20 | 0.08 | - | - | - | - | - | 0.03 |
| Nay | - | 0.06 | - | 0.33 | 0.10 | - | - | - | - | 0.08 | - | - |
| Mic | - | - | - | 0.17 | 0.50 | 0.08 | - | - | - | - | - | - |
| Oax | - | - | 0.14 | - | 0.10 | 0.23 | 0.38 | 0.33 | 0.40 | 0.17 | - | - |
| Chi | - | - | 0.07 | - | - | 0.15 | 0.25 | 0.33 | 0.10 | 0.17 | 0.67 | - |
| Yuc | - | - | - | - | - | 0.08 | 0.13 | - | - | - | - | - |
| Tab | - | - | - | - | - | 0.31 | 0.13 | - | 0.30 | 0.25 | 0.33 | 0.03 |
| Ver | - | - | - | - | - | 0.08 | 0.13 | 0.33 | 0.20 | 0.17 | - | - |
| Tam | - | - | - | - | - | - | - | - | - | 0.08 | 0.33 | 0.06 |
| Tx | 0.02 | - | - | - | - | - | - | - | - | - | - | 0.85 |

Pop. = collection areas (Az = Arizona, Chi = Chiapas, Mic = Michoacan, Nay = Nayarit, Oax = Oaxaca, Sin = Sinaloa, Son = Sonora, Tab = Tabasco, Tam = Tamaulipas, Tx = Texas, Ver = Veracruz, and Yuc = Yucatan); - = 0.

assumes any change in the total size of an allele is direct evidence of corresponding change in repeat number. For this assumption to be true, all loci must be pure repeats. Thus, the SMM lacks the ability to consider multiple changes that may occur in compound and complex loci (Kirchman et al. 2000). As a result of small sample size and concerns that locus motifs may have negatively influenced calculation of $(\delta\mu)^2$, SMM trees were removed from this study. NJ trees created from *Ds* and *Dps* matrixes were identical, and UPGMA trees generated from *Ds* and *Dps* measures differed only with the placement of the Yucatan population (*Dps* placed the Yucatan population

between Texas and Tamaulipas, and *Ds* placed the Yucatan population with Chiapas). Because Nei's *Ds* was designed to accommodate for small sample size, and to avoid redundancy, only trees generated from *Ds* calculations will be discussed.

NJ and UPGMA grouped Arizona with Sonora and showed separation between Arizona-Sonora and Sinaloa (Figure 5). Populations from south-central and southeastern Mexico (geographically Chiapas, Oaxaca, Tabasco, Veracruz, and Yucatan) comprised a distinct group with both NJ and UPGMA. Displaying the longest branch length with NJ and UPGMA, the Texas population clearly shows separation from the remainder of pygmy-owls in the U.S. and Mexico.

The program Bottleneck (Piry et al. 1999) and TPM were used to test for evidence of genetic bottlenecks in pygmy-owl populations. Based on a one-tailed Wilcoxon sign-rank test ($P < 0.05$), the Arizona and Sonora populations appear to have experienced a recent bottleneck. The one-tailed Wilcoxon sign-rank P value for Texas was 0.58. Using Hill's (1981) linkage-disequilibrium model and Waples's (1989) temporal method with moments based F -statistics in NeEstimator (Peel et al. 2000), N_e for the Arizona population was 29.5 (CI: 23.9-37.3, $P < 0.05$) and 15.5 (CI: 6.3-58.3, $P < 0.05$), respectively. Applying N_e estimation results to Nunney's (1993) equation for calculating N (number of adults in a population), the estimated N for pygmy-owls in Arizona was 59 (CI: 47.8-74.6, $P < 0.05$) for the linkage disequilibrium model and 31 (CI: 13-117, $P < 0.05$) for temporal moments model.

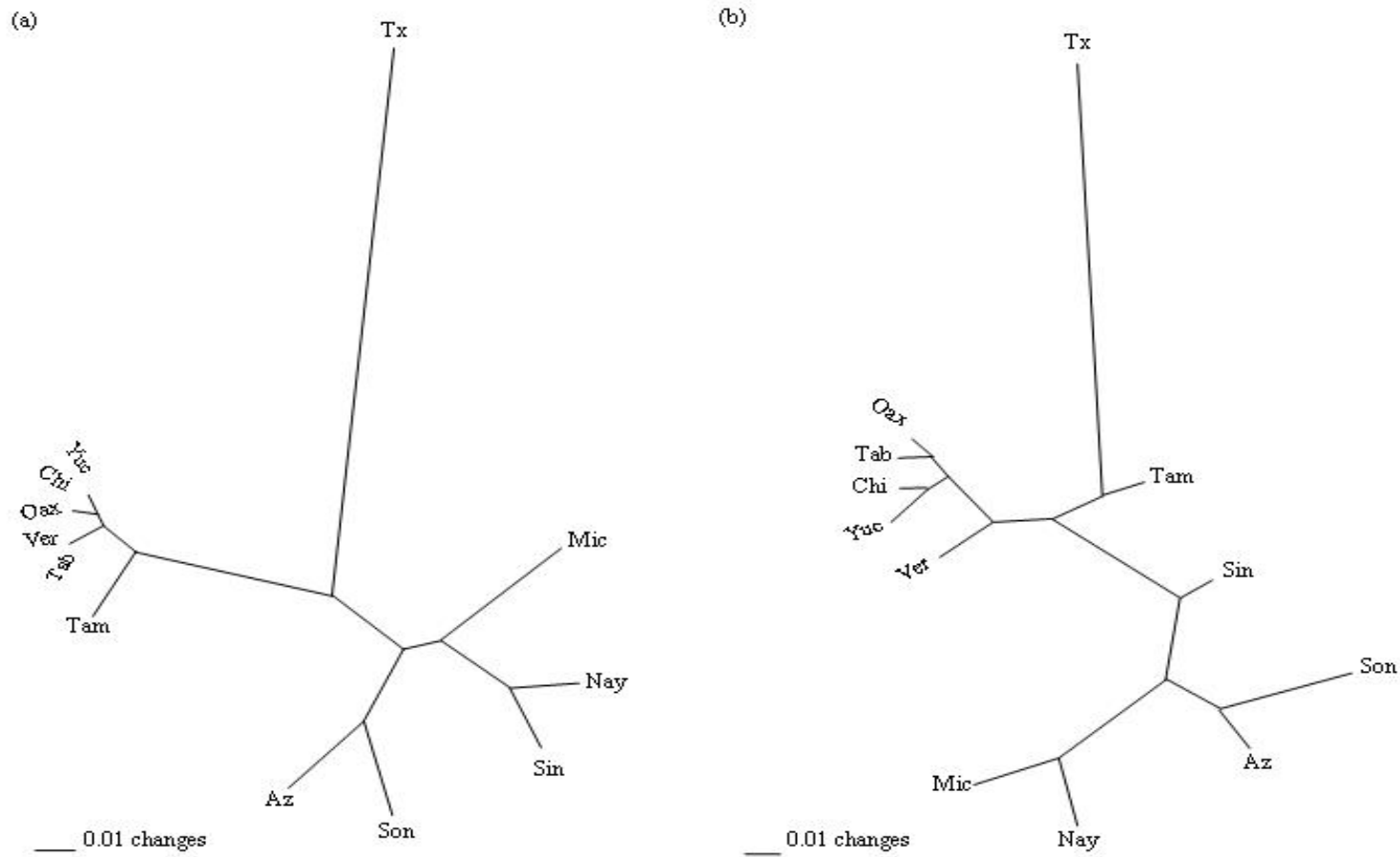

Figure 5. Relationship of pygmy-owl populations based on genetic distances of alleles in 11 polymorphic loci. Unrooted UPGMA (a) and NJ (b) trees are based on distance matrix from calculations of D_s . Calculations were performed using Microsat 1.4d (Minch 1995), trees were created using PAUP* 4.0 (Swofford 1999).

Discussion

Patterns of Genetic Diversity

With means of 9.5 alleles per locus and observed heterozygosity of 58%, estimates of pygmy-owl genetic diversity were average or high when compared to other nonmigratory avian species (Abbott et al. 2002, Chan & Arcese 2002, Williams et al. 2002, McDonald 2003, Koopman 2003, Bhagabati et al. 2004, Martínez-Cruz et al. 2004). An AMOVA indicated that most genetic variation in pygmy-owls occurred within rather than among populations. These results suggest high levels of gene flow exist across pygmy-owl populations in Mexico, and between pygmy-owl populations in the U.S. and Mexico. Alternative hypotheses include isolation for a length of time insufficient for differentiation to occur, or recent expansion from a common source (Williams et al. 2002). Examining the history of population growth in areas along the U.S.-Mexico border, and results from mtDNA and microsatellite analysis, both of these alternative hypotheses are possible. For example, Oberholser (1974) attributes a significant decline in pygmy-owl population numbers in Texas to urban and agricultural expansion from 1920 through 1945, and a resulting loss of 90% the woodlands along the Rio Grande. The remaining viable populations of pygmy-owls in Texas occur in a disjunct live oak-mesquite forest about 80 km north of the U.S.- Mexico border. If urban and agricultural development along the border has restricted gene flow between the remaining population in Texas and the continuous population in Mexico, the time of separation would be approximately 75 yrs (an extremely short period in genetic terms). Arizona has a similar history, from 1900 to 1930, the human population of Pima County,

Arizona increased from ca. 15,000 to 56,000. In 1950 census records indicate a population of ca. 141,000, and from 1950 to 1997, the population of Pima County increased almost 600% to ca. 800,000 individuals (U.S. Census Bureau, <http://www.census.gov/>). Johnson et al. (2003), drew correlates between the construction of dams from 1902 through the 1930s, a succeeding loss of riparian vegetation, and a significant reduction in pygmy-owl numbers from riparian areas along the Gila, Salt, and Verde rivers. The rapid population growth in Pima County with subsequent urban and agricultural expansion undoubtedly fragmented the landscape in southwestern Arizona and possibly disrupted historical pygmy-owl dispersal patterns. As with Texas, however, the time span between this data analysis and demographic events that may have disrupted gene flow in the Arizona population of pygmy-owls was extremely short on an evolutionary time scale.

Patterns of Gene Flow

Results from the assignment tests also suggest extensive gene flow across pygmy-owl populations. A fine scale examination of the data, however, reveals that most of the mismatches occurred in the center of the pygmy-owl's distributional range, with an almost geo-linear pattern of variation in the proportion of mismatches. This pattern revealed a decrease in percent mismatch with increasing latitude. Because pygmy-owls are nonmigratory with limited dispersal distance (Proudfoot & Johnson 2000) and the mismatch levels of Arizona and Texas were extremely low, the mismatches occurring outside neighboring populations in the Arizona and Texas groups are probably residual effects of recent expansion from the source population (as

indicated in Chapter II) and not evidence of continuous gene flow between populations in the U.S. and those throughout Mexico. The symmetry of the assignment tests suggests that gene flow follows a stepping-stone model (Kimura 1953), with neighboring populations showing the most similarity. Furthermore, nearly all of the mismatches occurred within and not between subspecies described from the analysis of mtDNA (Chapter II). Analysis of first migrants showed only one new migrant in the *G. b. cactorum* subspecies, whereas six were recorded in *G. b. ridgwayi*, the subspecies that occurs in south-central and southeastern Mexico. Because no individuals from Sinaloa were assigned to the Arizona or Sonora group, assignment tests support inferences from nested clade analysis (Chapter II) that suggest restricted gene flow with isolation by distance between Arizona-Sonora and Sinaloa populations. Data from assignment test indicate unidirectional exchange between Sonora and Sinaloa, with mismatches involving Sonora individuals in Sinaloa. Assignment of one individual from the Arizona group to Sinaloa is less than expected by chance ($P < 0.05$) and, hence does not indicate gene flow between the two populations. This association supports inferences from nested clade analysis of mtDNA sequences that indicated separation between the Sonoran and Sinaloan populations through fragmentation in gene flow and isolation by distance (Chapter II). With only one pygmy-owl throughout Mexico and Arizona being assigned to Texas, and only 9% of the Texas population being assigned outside neighboring Tamaulipas, a similar pattern of extremely limited exchange is evident in the Texas population. This association is congruent with mtDNA sequence analysis and indicates a higher level of gene flow within the south-central Mexico population relative

to other populations in the U.S. and Mexico. This level of separation may indicate a significant expansion within the Texas population since it split from the source population in Mexico. Here again, the separation of the Texas population was congruent with inferences mtDNA sequence data and nested clade analysis that indicated fragmentation in gene flow and isolation by distance between the Texas-Tamaulipas group and the population in south-central and southeastern Mexico. Additional support for restricted gene flow between Texas and populations to the south in Mexico is provided from the disproportionate number of private alleles, with Texas having more than three times the number of private alleles than seen in other populations. This evidence supports inferences from nested clade analysis (Chapter II) that suggest restricted gene flow and isolation by distance between the Texas-Tamaulipas group and the remaining populations in Mexico. Course assessment of assignment test data may be interpreted to indicate that the Arizona-Sonora and Texas-Tamaulipas populations are off on different evolutionary trajectories.

Phylograms created from *Dps* and *Ds* distance measures are similar to assignment tests with regard to connectivity (i.e., they consistently linked neighboring populations and showed the highest level of similarity among population of south-central and southeastern Mexico). Showing separation between Arizona-Sonora and Sinaloa, and Texas-Tamaulipas and the remainder of Mexico, patterns of microsatellite DNA variation provide a finer resolution of population structure than was evident from mtDNA analysis (Chapter II). MtDNA analysis partitioned pygmy-owls into two genetically distinct groups, one in Arizona, Sonora, and Sinaloa, and the other in Texas,

Tamaulipas, and regions of South-Central Mexico. These results are congruent with earlier taxonomic studies that recognized birds from these regions as distinct subspecies (van Rossem 1937, Peters 1940, Phillips 1966, König et al. 1999). In Chapter II, it was proposed that the separation was probably the consequence of northern expansion of the pygmy-owl range and barriers to gene flow provided by the Sierra Madre Occidental and the Sierra Madre Oriental, because pygmy-owls rarely occur above 1,300 m (Proudfoot & Johnson 2000). The additional separations revealed from microsatellite analysis reinforce this hypothesis.

Definition of Management Units

Molecular studies of owls (Heidrich & Wink 1994, Heidrich et al. 1995, Barrowclough et al. 1999) and many other birds have revealed similar geographic subdivisions (Avice 1994, Wink 1995, Wittmann et al. 1995, Wink et al. 1996, Zink et al. 1998 & 2001). Based on the genotypic separation that exists between the pygmy-owl populations of Arizona, Texas, and regions of South-Central Mexico, these data do not indicate genetic isolation between the distinct populations in the U.S. and those immediately across the border in either Sonora or Tamaulipas, Mexico. However, results from the TPM analysis, low estimates of N/N_e , and the discrepancy in the number of private alleles found in Arizona-Sonora and Texas populations indicate a recent bottleneck or founder event in populations in Arizona and Sonora, thus providing further evidence of a lack of gene flow between populations in the U.S. and those in Mexico. It has long been presumed that genetic variability should decrease in peripheral populations (Garner et al. 2004). Based on analysis of mtDNA (Chapter II), this seemed

to be a valid assumption. However, average heterozygosity levels in loci from Arizona refute this presumption and, thus, indicate that although the Arizona population shows signs of a genetic bottleneck, it has maintained a considerable level of genetic variability. Thus, information from this study suggests the need to develop separate management plans for populations in the U.S. (Chapter II). Furthermore, these data imply the need of concern over the endangered population in Arizona, because small populations that are geographically or genetically isolated are at higher risk of extinction (Avice 1994). Because results from mtDNA and microsatellite DNA imply restricted gene flow between the Arizona-Sonora group and the Sinaloa population, I recommend caution when developing management plans for endangered pygmy-owls in Arizona. For example, management agencies may consider excluding the Sinaloa group when estimating potential gene flow, immigration through dispersal, and projected recovery of pygmy-owls in Arizona.

These data may be used as guidelines for pygmy-owl recovery efforts (task 3 of the pygmy-owl recovery plan lists genetic data as essential information for pygmy-owl management, U.S. Fish & Wildlife Service 2003). However, due to the small sample size from some populations (e.g., Tamaulipas & Yucatan), additional research may be warranted to test these results. Without reservation, continued study should be conducted to determine the point of separation between populations of pygmy-owls from Sonora and Sinaloa. If the separation between Sonora and Sinaloa is valid, and not the effect of limited sampling, the Arizona-Sonora group should be considered a distinct management unit.

CHAPTER V

SUMMARY

This study provides evidence of geographic subdivision between pygmy-owl populations in North and South America that were previously considered one species (*G. brasilianum*), and supports König et al.'s (1999) recommendation that populations of *G. brasilianum* from Mexico, Texas, and Arizona represent a phylogenetically distinct group (*G. r. ridgwayi*). Patterns of mtDNA and microsatellite variation also provide strong evidence of two genetically distinct units in North America, one in Arizona, Sonora, and Sinaloa (*G. r. cactorum*) and the other in Texas, Tamaulipas, and regions of South-Central Mexico (*G. r. ridgwayi*) respectively. Nested clade analysis and assignment test results indicate restricted unidirectional gene flow between the Arizona-Sonora and Texas-Tamaulipas populations and the remainder of populations in Mexico. I hypothesize that the initial separation is probably the consequence of northern expansion of the pygmy-owl range and barriers to gene flow provided by the Sierra Madre Occidental and the Sierra Madre Oriental, because pygmy-owls rarely occur above 1,300 m (Proudfoot & Johnson 2000). Secondary separations are possibly the result of human population growth and urban and agricultural expansions in the U.S. and Mexico.

REFERENCES

- Abbott CL, Poldmaa T, Loughheed S, Clarke M, Boag PT (2002) Hierarchical analysis of genetic population structure in the noisy miner using DNA microsatellite markers. *Condor*, **104**, 652-656.
- American Ornithologists' Union (1957) *Check-list of North American Birds*. 5th ed. American Ornithologists Union, Baltimore, MD.
- American Ornithologists' Union (1998) *Check-list of North American Birds*, 7th ed. American Ornithologists' Union, Washington, DC.
- American Ornithologists' Union (2004) List of the 2,038 bird species (with scientific and english names) known from the A.O.U. check-list area.
birdshttp://www.aou.org/checklist/index..
- Awise JC (1994) *Molecular Markers, Natural History, and Evolution*. Chapman & Hall, New York.
- Awise JC (2000) *Phylogeography: The History and Formation of Species*. Harvard University Press, Cambridge, MA.
- Baker AJ, Marshall HD (1997) Mitochondrial control region sequences as tools for understanding the evolution of avian taxa. In: *Avian Molecular Systematics and Evolution* (ed. Mindell, DP), pp. 51-82, Academic Press, San Diego.
- Barrowclough GF (1992) Systematics, biodiversity, and conservation biology. In: *Systematics, Ecology, and the Biodiversity Crisis* (ed. Eldredge, N), pp. 121-143, Columbia University Press, New York.
- Barrowclough GF, Gutierrez RJ (1990) Genetic variation and differentiation in the

- spotted owl (*Strix occidentalis*). *Auk*, **107**, 737-744.
- Barrowclough GF, Gutierrez RJ, Groth JG (1999) Phylogeography of spotted owl (*Strix occidentalis*) populations based on mitochondrial DNA sequences: gene flow, genetic structure, and a novel biogeographic pattern. *Evolution*, **53**, 919-931.
- Bhacabati NK, Brown JL, Bowen BS (2004) Geographic variation in Mexican jays (*Aphelocoma ultramarina*): local differentiation, polyphyly or hybridization? *Mol. Ecol.*, **13**, 2721-2734.
- Bowcock AM, Ruiz-linares A, Tomfohrde J, Minch E, Kidd JR, Cavalli-Sforza LL (1994) High resolution human evolutionary trees with polymorphic microsatellites. *Nature*, **368**, 455-457.
- Brooks DR, McLennan DA (2001) A comparison of a discovery-based and an event-based method of historical biogeography. *J. Biogeogr.*, **28**, 757-767.
- Chan Y, Arcese P (2002) Subspecific differentiation and conservation of song sparrows (*Melospiza melodia*) in the San Francisco Bay region inferred by microsatellite loci analysis. *Auk*, **119**, 641-657.
- Clement M, Posada, D, Crandall KA (2000) TCS: A computer program from coalescent theory with applications to intraspecific phylogeny reconstruction. *Genetics*, **134**, 959-969.
- Cody M, Moran R, Rebman J, Thompson H (2002) Plants. In: *A New Island Biogeography of the Sea of Cortés* (eds. Case TJ, Cody ML, Ezcurra E), pp 63-112, Oxford University Press, New York.
- Crandall KA, Templeton AR (1993) Empirical tests of some predictions from coalescent

- theory with applications to intraspecific phylogeny reconstruction. *Genetics*, **134**, 959-969.
- Csiki I, Lam C, Key A, Coulter E, Clark JD, Pace III RM, Smith KG, Rhoads DD (2003) Genetic variation in black bears in Arkansas and Louisiana using microsatellite DNA markers. *J. Mammol.*, **84**, 691-701.
- Don RH, Cox PT, Wainwright BJ, Baker K, Mattick JS (1991) "Touchdown" PCR to circumvent spurious priming during gene amplification. *Nucleic Acids Res.*, **19**, 4008.
- Eggert LS, Mundy NI, and Woodruff DS (2004) Population structure of loggerhead shrikes in the California Channel Islands. *Mol. Ecol.*, **13**, 2121-2133.
- Enríquez-Rocha, P., J. L. Rangel-Salazar, and D. W. Holt. 1993. Presence and distribution of Mexican owls: a review. *J. Raptor Res.*, **27**, 154–160.
- Estoup A, Cornuet JM (2000) Microsatellite evolution: inferences from population data. In: *Microsatellites: Evolution and Applications* (eds. Goldstein DB, Schlotterer C), pp 49-65, Oxford University Press, Oxford.
- Excoffier L., Smouse PE, Quattro JM (1992) Analysis of molecular variance inferred from metric distances among DNA haplotypes: application to human mitochondrial DNA restriction data. *Genetics*, **131**, 479-491.
- Falls BA (1973) Noteworthy bird records from south Texas (Kenedy County). *Southwest. Nat.*, **18**, 244-247.
- Farris JS (1969) Successive approximation approach to character weighting. *Syst. Zool.* **18**, 374-385.

- Felsenstein J (1985) Confidence limits on phylogenies: an approach using the bootstrap. *Evolution*, **39**, 783-791.
- Friedmann H, Griscom L, Moore RT (1950) Distributional check-list of the birds of Mexico. *Pt. 1. Pac. Coast Avifauna* 29, Cooper Ornithological Club, Berkeley, CA.
- Gaggiotti OE, Lange O, Rassmann K, Gliddon C (1999) A comparison of two indirect methods of estimating average level of gene flow using microsatellite data. *Mol. Ecol.*, **8**, 1513-1520.
- Garner TWJ, Pearman PB, Angelone S (2004) Genetic diversity across a vertebrate species' range: a test of the centraperipheral hypothesis. *Mol. Ecol.*, **13**, 1047-1053.
- Gilman MF (1909) Some owls along the Gila River in Arizona. *Condor*, **11**, 145-152.
- Goudet J, Raymond M, De Meeüs T, Russet F (1996) Testing differentiation in diploid populations. *Genetics*, **144**, 933-940.
- Guo SW, Thompson EA (1992) Performing the exact test of Hardy-Weinberg proportions for multiple alleles. *Biometrics*, **48**, 361-372.
- Griscom L, Crosby MS (1926) Birds of the Brownsville region, southern Texas. *Auk*, **43**, 18-36.
- Haig SM, Avise JC (1995) Avian conservation genetics. In: *Conservation Genetics: Case Histories from Nature* (eds. Avise JC, Hamrick JL), pp. 160-189, Chapman and Hall, New York.
- Haldane JBS (1954) An exact test for randomness of mating. *J. Genetics*, **52**, 631-635.

- Hauswaldt, J. S. and T. C. Glenn. (2003) Microsatellite DNA loci from the Diamondback terrapin (*Malaclemys terrapin*). *Mol. Ecol. Notes*, **3**, 174–176.
- Heidrich P, König C, Wink M (1995) Molecular phylogeny of the South American *Otus atricapillus* complex (Aves Strigidae) inferred from nucleotide sequences of cytochrome b gene. *Z. Naturforsch.*, **50**, 294-302.
- Heidrich P, Wink M (1994) Tawny Owl (*Strix aluco*) and Hume's Tawny Owl (*Strix butleri*) and distinct species: evidence from nucleotide sequences of the cytochrome b gene. *Z. Naturforsch.*, **49**, 230-244.
- Hewitt GM (1996) Some genetic consequences of ice ages, and their role in divergence and speciation. *Biol. J. Linn. Soc.*, **58**, 247-246.
- Hewitt GM (2000) The genetic legacy of the Quaternary ice ages. *Nature*, **405**, 907-913.
- Hill WG (1981) Estimation of population size from data on linkage disequilibrium. *Genet. Res.*, **38**, 209-216.
- Holt DW, Berkely R, Deppe C, Enriquez-Rocha PL, Olsen PD, Peterson JL, Rangel-Salazar JL, Segars KP, Wood KL (1999) Ferruginous Pygmy-Owl. In: *Handbook of the Birds of the World*, Vol. 5 (eds. del Hoyo J, Elliot A, Sargatal J), p. 217, Lynx Edicions, Barcelona.
- Howard R, Moore A (1980) *A Complete Checklist of the Birds of the World*. Oxford University Press, New York.
- Hudson RR, Slatkin M & Maddison WP (1992). Estimation of levels of gene flow from DNA sequence data. *Genetics*, **132**, 583-589.
- Jin L, Baskett ML, Cavalli-Sforza LL, Zhivotovsky LA, Feldman MW, Rosenberg NA

- (2000) Microsatellite evolution in modern humans: a comparison of two data sets from the same populations. *Ann. Hum. Genet.*, **64**, 117-134.
- Johns GC, Avise JC (1998) A comparative summary of genetic distances in the vertebrates from the mitochondrial cytochrome b gene. *Mol. Biol. Evol.*, **15**, 1481-1490.
- Johnson RR, Cartron JLE, Haight LT, Duncan RB, Kingsley KJ (2003) Cactus ferruginous pygmy-owl in Arizona, 1872-1971. *Southwest. Nat.*, **48**, 389-401.
- Johnson RR, Haight LT, Simson JM (1979) Owl populations and species status in the southwestern United States. In *Owls of the West: Their Ecology and Conservation*. Symposium Proceedings (P. Schaeffer and SM Ehlers, eds.) Pp. 40-59, National Audubon Society Western Education Center, Tiburon.
- Kimura M (1953) "Stepping-stone" model of population. *Annu. Rep. Natl. Inst. Genet. Japan*, **3**, 62-63.
- Kirchman JJ, Whittingham LA, Sheldon FH (2000) Relationships among cave swallow populations (*Petrochelidon fulva*) determined by comparisons of microsatellite and cytochrome b data. *Mol. Phyl. Evol.*, **14**, 107-121.
- Klicka J, Zink RM (1997) The importance of recent ice ages in speciation: a failed paradigm. *Science*, **277**, 1666-1669.
- Klicka J, Zink RM (1999) Pleistocene effects on North American songbird evolution. *Proc. R. Soc. London*, **B266**, 695-700.
- König, C, Weick F, Becking J-H (1999) Ridgway's Pygmy Owl. In *Owls: A Guide to Owls of the World*. Pp. 372-373, Yale University Press, New Haven, CT.

- König C, Wink M (1995) A new species of Ferruginous Pygmy-Owl from Argentina: *Glaucidium brasilianum stranecki* n. ssp. *J. Ornithol.*, **136**, 461-465.
- Koopman ME (2003) *Genetic Structure of Boreal Owls*. Ph.D. dissertation, Univ. Wyoming, Laramie.
- Larson S, Jameson R, Bodkin J, Staedler M, Bentzen P (2002) Microsatellite DNA and mitochondrial DNA variation in remnant and translocated sea otter (*Enhydra lutris*) populations. *J. Mammol.*, **83**, 893-906.
- Maroja LS, Almeida FC, Seuánez (2003) Genetic differentiation in geographically close populations of the water rat *Nectomys squamipes* (Rodentia, Sigmodontinae) from the Brazilian Atlantic forest. *Genet. Mol. Biol.*, **26**, 403-410.
- Martinez-Cruz R, Godoy JA, Negro JJ (2004) Population genetics after fragmentation: the case of the endangered Spanish imperial eagle (*Aquila adalberti*). *Mol. Ecol.*, **13**, 2243-2255.
- McDonald DB (2003) Microsatellite DNA evidence for gene flow in neotropical lek-mating long-tailed manakins. *Condor*, **105**, 580-586.
- Michalakis Y, Excoffier L (1996) A generic estimation of population subdivision using distances between alleles with special interest to microsatellite loci. *Genetics*, **142**, 1061-1064.
- Millsap GA (1987) Introduction to federal laws and raptor management. In: *Raptor Management Techniques Manual*, (eds. Pendleton BG, Millsap BA, Cline KW, Bird DM), p. 24, Institute for Wildlife Research, National Wildlife Federation, Scientific Technical Series No. 10, Port City Press, Baltimore.

- Minch E (1995) MICROSAT 1.4d, a program for calculating distances from microsatellite data. (<http://hpgl.stanford.edu/projects/microsat/>).
- Moore WS, DeFilippis VR (1997) The window of taxonomic resolution for phylogenies based on mitochondrial cytochrome b. In: *Avian Molecular Evolution and Systematics*, (ed. Mindell DP), pp. 83-119, Academic Press, San Diego.
- Moritz C (1994) Defining 'evolutionarily significant units' for conservation. *Trends Ecol. Evol.*, **9**, 373-375.
- Muwanika VB, Siegismund HR, Okello JBA, Masembe C, Arctander P, Nyakaana S (2003) A recent bottleneck in the warthog and elephant population of Queen Elizabeth National Park, revealed by a comparative study of four mammalian species in Uganda National parks. *Anim. Conserv.*, **6**, 1-10.
- Nei M (1972) Genetic distance between populations. *Am. Nat.*, **106**, 283-292.
- Nei M (1978) Estimation of average heterozygosity and genetic distance from a small number of individuals. *Genetics*, **3**, 489-495.
- Nei M (1987) *Molecular Evolutionary Genetics*. Columbia University Press, New York.
- Oberholser HC (1974) *The Bird Life of Texas*. University of Texas Press, Austin.
- Paetkau D, Calvert W, Striling J, Strobeck C (1995) Microsatellite analysis of population structure in Canadian polar bears. *Mol. Ecol.*, **4**, 347-354.
- Paetkau D, Slade R, Burden M, Estoup A (2004) Genetic assignment methods for the direct, real-time estimation of migration rate: a simulation-based exploration of accuracy and power. *Mol. Ecol.*, **13**, 55-65.
- Paetkau D, Waits LP, Ckarkson PL, Craighead L, Strobeck C (1997) An emperical

- evaluation of genetic distance statistics using microsatellite data from bear (Ursidae) populations. *Genetics*, **147**, 1943-1957.
- Palumbi SR, Cipriano F, Hare MP (2001) Predicting nuclear gene coalescence from mitochondrial data: the three-time rule. *Evolution*, **55**, 859-868.
- Peel D, Ovenden JR, Peel SL (2004) NeEstimator: software for estimating effective population size, Version 1.3. Queensland Government, Department of Primary Industries and Fisheries, Brisbane, Australia.
- Pérez T, Albornoz J, Domínguez (2002) Phylogeography of chamois (*Rupicapra* spp.) inferred from microsatellites. *Mol. Phylo. Evol.*, **25**, 524-534.
- Peters JL (1940) *Check-list of Birds of the World*, Vol. 4. Harvard University Press, Cambridge, MA.
- Phillips AR (1966) Further systematic notes on Mexican birds. *Bull. British Ornithol. Club*, **86**, 86-94.
- Piry S, Alapetite A, Cornuet JM, Paetkau D, Baudouin L, Estoup A. (2004) GeneClass2: a software for genetic assignment and first-generation migrant detection. *J. Heredity*, **95**, 536-539.
- Piry S, Luikart G, Cornuet JM (1999) Bottleneck: a computer program for detecting recent reductions in the effective population size using allele frequency data. *J. Heredity*, **90**, 502-503.
- Posada D, Crandall KA (1998) Modeltest: testing the model of DNA substitution. *Bioinformatics*, **14**, 817-818.
- Posada D, Crandall KA, Templeton AR (2000) GeoDis: a program for the cladistic

- nested analysis of the geographical distribution of genetic haplotypes. *Mol. Ecol.*, **9**, 487-488.
- Primmer CR, Saino N, Moller AP, Ellegren H (1998) Unraveling the processes of microsatellite evolution through analysis of germ line mutations in barn swallows (*Hirundo rustica*). *Mol. Biol. Evol.*, **15**, 1047-1054.
- Proudfoot GA, Johnson RR (2000) Ferruginous Pygmy-Owl (*Glaucidium brasilianum*). In: *The Birds of North America*, No. 498 (eds. Poole A, Gill F), The Birds of North America, Inc., Philadelphia.
- Raymond M., Rousset F. (1995a) GENEPOP Version 2.1: population genetics software for exact tests and ecumenicism. *J. Heredity*, **86**, 248–249.
- Raymond M., Rousset F. (1995b) An exact test for population differentiation. *Evolution*, **49**, 1280-1283.
- Rice WR (1989) Analyzing tables of statistical tests. *Evolution*, **43**, 223-225.
- Ridgway R (1914) *Glaucidium brasilianum ridgwayi* (Sharpe). In: *The Birds of North and Middle America*. Pp. 798-804, Pt 6, U. S. Natl. Mus. Bull.
- Ronquist F, Huelsenbeck JP (2003) MrBayes 3: Bayesian phylogenetic inference under mixed models. *Bioinformatics* **19**, 1572-4.
- Rozas J, Sánchez-DelBarrio, J. C., Messeguer, X. and Rozas, R. (2003). DnaSP, DNA polymorphism analyses by the coalescent and other methods. *Bioinformatics*, **19**, 2496-2497.
- Ryberg WA, Fitzgerald LA, Honeycutt RL, Cathy JC (2002) Genetic relationships of American alligator populations distributed across different ecological and

- geographical scales. *J. Exper. Zool.*, **294**, 325-333.
- Saiki RK, Gelfand DH, Stoffel S (1988) Primer-directed enzymatic amplification of DNA with a thermostable DNA polymerase. *Science*, **239**, 487-491.
- Schiels GF, Wilson AC (1987) Calibration of mitochondrial DNA evolution in geese. *J. Mol. Evol.*, **24**, 212-217.
- Schneider S, Roessli D, Excoffier L (2000) ARLEQUIN: a software for population genetics data analysis, Version 2.000, <http://anthro.unige.ch/arlequin>, Geneva.
- Sorenson MD, Fleischer RC (1996) Multiple independent transpositions of mitochondrial DNA control region sequences to the nucleus. *Proc. Natl. Acad. Sci. USA*, **93**, 15239-15243.
- Sorenson MD, Quinn TW (1998) Numts: a challenge for avian systematics and population biology. *Auk*, **115**, 214-221.
- Swofford DL (1999) PAUP* Phylogenetic Analysis Using Parsimony (*and other methods), Ver 4.0b2. Sinauer, Sunderland, MA.
- Takezaki N, Nei M (1996) Genetic distance and reconstruction of phylogenetic trees from microsatellite DNA. *Genetics*, **144**, 389-399.
- Tamura K, Nei M (1993) Estimation of the number of nucleotide substitutions in the control region of mitochondrial DNA in humans and chimpanzees. *Mol. Biol. Evol.*, **10**, 512-526.
- Templeton AR (1998) Nested clade analyses of phylogeographic data: testing hypotheses about gene flow and population history. *Mol. Ecol.*, **7**, 381-397.
- Templeton AR (2004) Statistical phylogeography: methods of evaluating and

- minimizing inference errors. *Mol. Ecol.*, **13**, 789-809.
- Templeton AR, Crandall KA, Sing CF (1992) A cladistic analysis of phenotypic associations with haolotypes inferred from restriction endonuclease mapping and DNA sequence data.III. cladogram estimation. *Genetics*, **132**, 619-633.
- Templeton AR, Routman E, Phillips CA (1995) Separating population structure from population history: a cladistic analysis of the geographical distribution of mitochondrial DNA haplotypes in tiger salamander, *Ambystoma tigrinum*. *Genetics*, **140**, 767-782.
- Thode AB, Maltibie M, Hansen LA, Green LD, Longmire JL (2002) Microsatellite markers for the Mexican spotted owl (*Strix occidentalis lucida*). *Mol. Ecol. Notes*, **2**, 446-448.
- U. S. Fish and Wildlife Service (1994) Endangered and threatened wildlife and plants: proposed rule to list the Cactus Ferruginous Pygmy-Owl as endangered with critical habitat in Arizona and threatened in Texas. *Fed. Regist.*, **59**, 63975-63986.
- U. S. Fish & Wildlife Service (1997) Endangered and threatened wildlife and plants: determination of endangered status for the cactus ferruginous pygmy-owl in Arizona. *Fed. Regist.*, **62**, 10730-10747.
- U.S. Fish & Wildlife Service (2003) Cactus ferruginous pygmy-owl (*Glaucidium brasilianum cactorum*) draft recovery plan. Albuquerque, NM.
- van Rossem AJ (1937) The ferruginous pygmy owl of northwestern Mexico and Arizona. *Proc. Biol. Soc. Wash.*, **51**, 27-28.

- Waples RS (1989) A generalized approach for estimating effective population size from temporal changes in allele frequency. *Genetics*, **121**, 379-391.
- Watterson GA (1975) On the number of segregating sites in genetic models without recombination. *Theor. Popul. Biol.*, **7**, 256-276.
- Webb T, Bartlein PJ (1992) Global changes during the last 3 million years: climatic controls and biotic responses. *Annu. Rev. Ecol. Syst.*, **23**, 141-173.
- Weir BS (1990) *Genetic Data Analysis*. Sinauer Publ., Sunderland, MA.
- Weir BS, Cockerham CC (1984) Estimating F-statistics for analysis of population structure. *Evolution*, **38**, 1358-1370.
- Williams CL, Fedynich AM, Pence DB, Rhodes OE Jr. (2005) Evaluation of allozyme and microsatellite variation in Texas and Florida mottled ducks. *Condor*, **107**, 155-161.
- Wink M (1995) Phylogeny of Old and New World vultures (Aves: Accipitridae and Cathartidae) inferred from nucleotide sequences of mitochondrial cytochrome b gene. *Z. Naturforsch.*, **50**, 868-882.
- Wink M & Heidrich P (1999) Molecular evolution and systematics of owls (Strigiformes). In: *Owls: A Guide to Owls of the World* (Konig C, Weick F, Beckin JH, Eds.), pp 39-57, Yale University Press, New Haven, CT.
- Wink M, Heidrich P, Fentzloff C (1996) A mtDNA phylogeny of sea eagles (genus *Haliaeetus*) based on nucleotide sequences of the cytochrome b gene. *Biochem. Syst. Ecol.*, **24**, 783-791.
- Wittmann U, Heidrich P, Wink M, Gwinner E (1995) Speciation in the stonechat

- (*Saxicola torquata*) inferred from nucleotide sequences of the cytochrome b gene. *J. Zool. Syst. Evol.*, **33**, 116-122.
- Wright S (1931) Evolution in Mendelian populations. *Genetics*, **16**, 97-159.
- Zink RM (1997) Comparative phylogeography of North American birds. In: *Avian Molecular Evolution and Systematics* (ed. Mindell DP), pp. 301-324, Academic Press, San Diego.
- Zink RM (2002) Methods in comparative phylogeography, and their application to studying evolution in the North American aridlands. *Integrat. Compar. Biol.* **42**, 953-959.
- Zink RM, Barrowclough GF, Atwood JL, Blackwell-Rago RC (2000) Genetics, taxonomy, and conservation of the threatened California gnatcatcher. *Conserv. Biol.* **14**, 1394-1405.
- Zink RM, Blackwell-Rago RC (2000) Species limits and recent population history in the curve-billed thrasher. *Condor*, **102**, 881-886.
- Zink RM, Blackwell-Rago RC, Ronquist F (2000) The shifting roles of dispersal and vicariance in biogeography. *Proc. R. Soc. London*, **B 267**, 497-503.
- Zink RM, Kessen AE, Line TV, Blackwell-Rago RC (2001) Comparative phylogeography of some aridland bird species. *Condor*, **103**, 1-10.
- Zink RM, Weller SJ, Blackwell RC (1998) Molecular phylogenetics of the avian genus *Pipilo* and a biogeographical argument for taxonomic uncertainty. *Mol. Phyl. Evol.*, **10**, 191-201.

VITA

I. Personal Information

Glenn Arthur Proudfoot, Born 5 September 1955, Glenwood, Minnesota
 Current address: Box 351, Vassar College, 124 Raymond Ave., Poughkeepsie,
 NY 12604

II. Education

B.S. December 1993
 University of Wisconsin-Stevens Point, Biology

M.S. May 1996
 Texas A&M University-Kingsville, Range & Wildlife Management

III. Fellowships

Sloan Fellow, 1999-2004
 Caesar Kleberg Research Fellow, 1994-1996

IV. Publications

Proudfoot GA, Honeycutt RL, Slack RD (2005) Development and
 characterization of microsatellite DNA primers for ferruginous pygmy-
 owls (*Glaucidium brasilianum*). *Mol. Ecol. Notes*, **5**, 90-92.

Proudfoot GA, Beasom S, Chavez-Ramirez F, Mays JL (2002) Response
 distance of Ferruginous Pygmy-Owls to broadcasted conspecific calls. *J.*
Raptor Res., **36**, 170-176.

Proudfoot GA (2002) Two optic systems assist removal of nestling ferruginous
 pygmy-owls from nest cavities. *Wildl. Soc. Bull.*, **30**, 1-4.

Proudfoot, G. A., and E. Jacobs. 2001. Bow net equipped with radio alarm. *Wildl.*
Soc. Bull., **29**, 543-545.

Proudfoot GA & Johnson RR (2000) Ferruginous Pygmy-Owl (*Glaucidium*
brasilianum). In *The Birds of North America* (A. Poole and F. Gill, eds.).
 Academy of Natural Science, Philadelphia, Pa; American Ornithologists
 Union, Washington, DC.

Proudfoot GA, Sherry DA, Johnson S (2000) Cactus Wren (*Campylorhynchus*
brunneicapillus). In *The Birds of North America* (A. Poole and F. Gill,
 eds.). Academy of Natural Science, Philadelphia, Pa; American
 Ornithologists Union, Washington, DC.